

MARCH 1976

HEWLETT-PACKARD JOURNAL



A Cesium Beam Frequency Reference for Severe Environments

Systems operating in demanding environments, including airborne, marine, and land mobile, can now benefit from the accuracy and stability of the cesium atom as a time and frequency reference.

by Charles E. Heger, Ronald C. Hyatt, and Gary A. Seavey

A NEW CESIUM BEAM FREQUENCY REFERENCE combines precision comparable to the best laboratory standards with the ruggedness and compactness needed to operate in the extreme environments sometimes encountered in ships and aircraft. Navigation and communications systems are typical applications that require such precise frequency and/or time.

Model 5062C Cesium Beam Frequency Reference, Fig. 1, has 2/3 the volume of current HP cesium standards and weighs only 32 kg (70 lb) with its optional internal one-hour standby battery. Its small size, ruggedness, and internal battery make it suitable for a wide range of applications.

An optional 24-hour digital clock with front-panel readout provides timekeeping capability. The clock generates a one-pulse-per-second output that can be advanced or retarded with a resolution of 100 ns. A time code output is optional.

The 5062C has few operator controls, is easily placed in operation, and requires a minimum of monitoring. It is accurate within ± 3 parts in 10^{11} over a wide temperature range of -28° to $+65^{\circ}\text{C}$ and in magnetic fields up to 2 gauss peak.

A Brief History

The history of cesium beam clock development has its roots in the discovery of quantum mechanics although exploitation on a large scale dates back only about two decades. The knowledge upon which cesium beam clocks are based developed from the study of the absorption and emission of electromagnetic radiation by matter. The concepts of the electron and the nucleus of the atom, the quantization of the energy of atoms, and the quantization of the electromagnetic field, discovered by Thompson, Rutherford, Planck, Einstein and Bohr, combined with the theories of Schroedinger and Heisenberg in 1926, led

to the establishment of quantum mechanics. Much work was done in the 1930's in developing atomic beam and magnetic resonance techniques. According to Hershberger and Norton,¹ I.I. Rabi made the specific suggestion of using atomic or molecular transitions in an atomic clock in January 1945.

The first complete operational "atomic clock" was developed at the United States National Bureau of Standards in 1948-1949. It used a quartz resonator stabilized by an absorption line in ammonia.

The first operational cesium beam standard was



Cover: *The new rugged Model 5062C Cesium Beam Frequency Reference and the new 15-centimeter cesium beam tube that makes it possible.*

In this Issue:

A Cesium Beam Frequency Reference for Severe Environments, by Charles E. Heger, Ronald C. Hyatt, and Gary A. Seavey **page 2**

Calibrated FM, Crystal Stability, and Counter Resolution for a Low-Cost Signal Generator, by Robert R. Collison and Ronald E. Kmetovicz **page 11**

A 50-Mbit/s Pattern Generator and Error Detector for Evaluating Digital Communications System Performance, by Ivan R. Young, Robert Pearson, and Peter M. Scott **page 18**

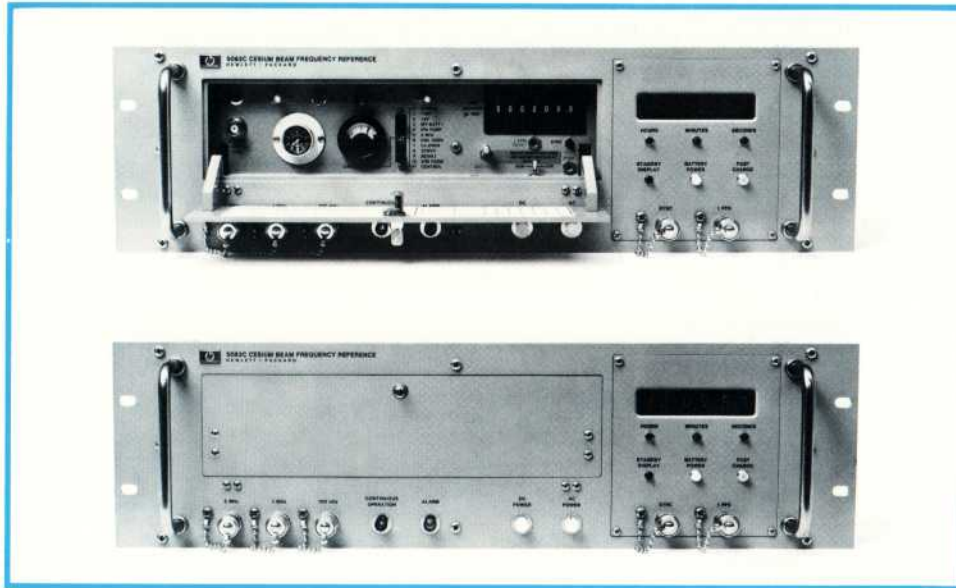

Fig. 1. Model 5062C Cesium Beam Frequency Reference is designed for navigation, communications, and guidance systems, and other applications requiring laboratory-standard accuracy in a rugged, compact instrument. Specified accuracy is $\pm 3 \times 10^{-11}$ over a temperature range of -28° to $+65^\circ\text{C}$. Weight is 32 kg with optional standby battery.

developed at the National Physical Laboratory in England in 1955. By 1958 similar devices were in operation at NBS, National Research Council (NRC) in Canada, and Laboratoire Suisse de Recherches Horlogeres (LSRH) in Switzerland. In all of these early cesium beam standards, the frequency of the quartz oscillator was manually steered to the peak of the cesium energy state transition resonance and then compared with the unknown frequency to be measured.

By 1954, J. Zacharias, J. Yates, and R. Haun at Massachusetts Institute of Technology had been able to electronically stabilize the frequency of a quartz oscillator with the cesium transition. The authors suggested that this technique should make a commercial cesium standard feasible, and in 1956 the National Company introduced the first commercial cesium beam standard. Its cesium beam tube was six feet long.

Hewlett-Packard introduced the first portable cesium standard in 1964, leading to the well known flying clock experiments in 1965 through 1967.^{2,3,4,5} Emphasis was placed on a short 41-cm (16-in) tube with high accuracy and long life. To date over 1000 of these devices have been put into service in two generations of cesium standards.^{6,7}

However, as early as 1966 the need was recognized for an even smaller, more rugged cesium beam reference for use in aircraft navigation systems. In the next few years, development work was completed on a much smaller 15-cm (6-in) cesium beam resonator suitable for the high shock, vibration, and acceleration levels encountered in aircraft and shipboard applications. A complete clock was developed for evaluation flights of the aircraft collision avoidance system (CAS) then being proposed by the Air Transport Association. The unit was test flown in the fall of

1971 and demonstrated excellent performance. However, due to the delay in the acceptance of a suitable worldwide CAS, this unit has never been mass produced. Instead, its design was modified to make it more of a general-purpose product suitable for both shipboard and aircraft applications. Now available as the 5062C, it has nearly the same high accuracy and approaches the stability of previous HP cesium standards with a much higher level of environmental ruggedness.

Cesium Beam Resonator

The design criteria for developing the small cesium beam tube specified that it be smaller, weigh less, and have lower power consumption and shorter warm-up time than cesium beam tubes available at the time. The small tube was to be rugged and have comparable performance to the much longer HP 5061A cesium beam tube (see Fig. 2). These goals were to be achieved with a minimum of performance compromise.

The compact tube with its shorter length posed a problem of degradation of short-term stability. Short-term stability is a function of the beam strength and the drift length between the oscillating fields in the two arms of the Ramsey microwave cavity. It is improved as the beam strength is increased and degraded as the Ramsey drift length is decreased. This can be shown by the following equation for the standard deviation of the fractional frequency fluctuations for averaging times from one second to 10^4 seconds.⁸

$$\sigma_y(2, \tau) = \frac{0.776}{f F \tau^{1/2}}$$

where f is the resonant frequency, F is a beam tube

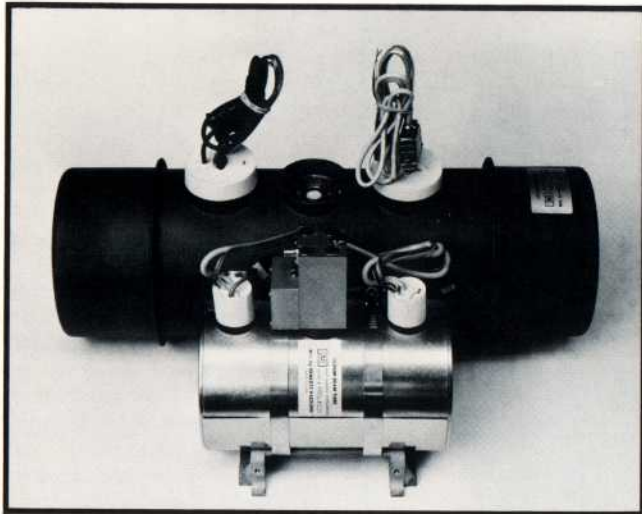

Fig. 2. The principal component in the 5062C Cesium Beam Frequency Reference is a new 15-cm cesium beam tube, shown here next to the 41-cm tube used in other HP cesium beam standards.

figure of merit, and τ is averaging time. The beam tube figure of merit F is defined as the signal-to-noise ratio for a $\frac{1}{4}$ -Hz bandwidth divided by the beam tube line width.

Substituting the appropriate values for f and F the equation becomes:

$$\sigma_y(2,\tau) = \frac{K}{N^{1/2}l\tau^{1/2}}$$

where N is beam strength, l is Ramsey drift length, and K is a constant for the particular beam tube geometry.

To offset the shorter drift length and preserve short-term stability, the beam strength was increased. The short cesium beam tube's internal components—oven, state selection magnets, microwave cavity, and detector—are designed to simulate twelve beam tubes in parallel (Fig. 3). The cesium oven forms and aims the twelve cesium beams by means of a multitube collimator. The twelve beams provide twelve times the beam strength or approximately 3.5 times the figure of merit for a particular tube geometry while still using the theoretically optimum cesium tube beam optics.

The state selection magnets each function as twelve independent state selection devices, each spatially separating the atoms of its beam into two groups. The microwave cavity and detector are designed to accommodate the twelve beams simultaneously.

The relative locations of the parallel beams are chosen so the sensitivity of the cesium beam tube to acceleration and vibration is greatly decreased. Acceleration normal to the beam path changes the effective beam optics; when the cesium atoms leave the oven the detector is at a particular position, but it takes a finite time (about 1.14 ms) for the cesium atoms to travel to the detector, and when the atoms arrive at the original position of the detector it has moved to a new location. The result is that some of the atoms from one set of six beams that would have reached the detector now miss it. On the other hand, approximately an equal number of atoms from the other set of six beams that would not have reached the detector under static conditions now reach the detector and become useful beam. Therefore, the two sets of six beams tend to complement each other and

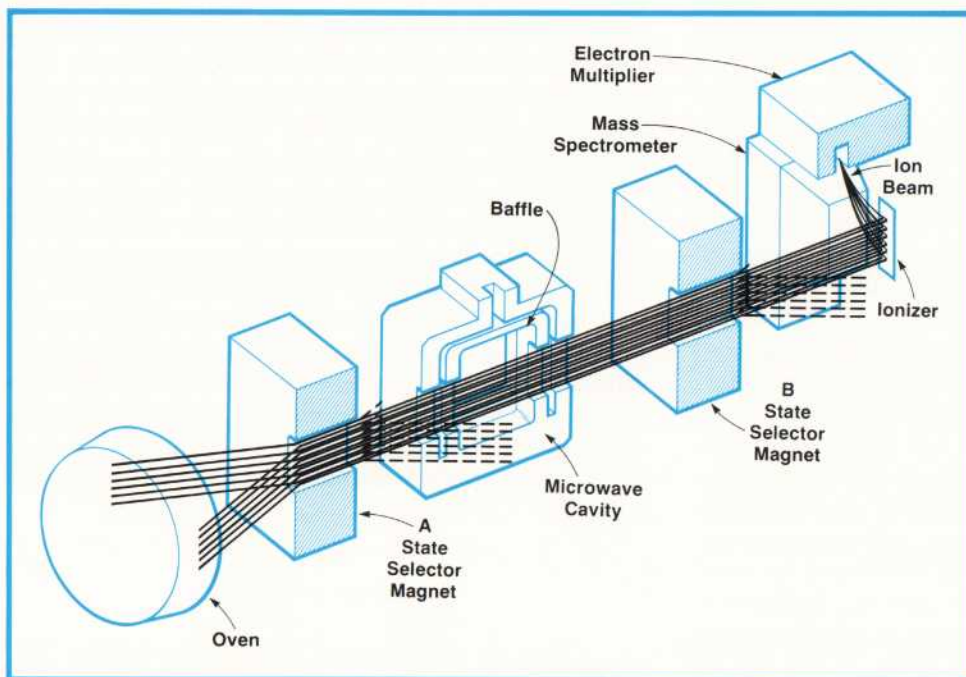

Fig. 3. The small beam tube uses 12 parallel beams to maintain short-term stability despite its short length. The 12 beams also improve its tolerance to acceleration.

cancel the effects of acceleration.

As a result of the greatly increased beam strength and total cesium expenditure a new challenge was encountered: effective cesium getting, or the collection of unused cesium atoms that would add to the cesium beam tube's background signal level and therefore degrade the cesium beam tube's overall performance.

This problem was handled by constructing a maze of gettering material that the unused cesium atoms enter and are trapped in. The maze is constructed to maximize the number of times an unused cesium atom comes in contact with getter material, thus increasing the probability that the unused cesium atom will be gettered. It is anticipated that this tube should have a life comparable to those of the previous HP tubes, which approach five years.

To reduce the cesium beam tube's size, weight, power consumption, and warmup time while increasing its ruggedness, a completely new mechanical mounting approach was adopted. All of the beam tube's internal components, cesium source, state selection magnets, microwave structure, magnetic shields, electron multiplier, ionizer, mass spectro-

meter, and ion pump are mounted between two parallel plates whose relative positions are fixed by a cylindrical structure that also doubles as the vacuum envelope of the cesium beam tube. This type of mechanical mounting provides for better mechanical integrity under adverse environmental conditions such as vibration and shock. The mechanical mounting was also designed to increase the thermal isolation of the internal components from the external environment, to reduce the tube's power consumption and warm-up time.

The cesium beam tube is assembled with a temperature compensator at its RF input that compensates for the dimensional changes of its internal microwave cavity with changing environmental conditions and keeps it electrically matched to the RF sources.

How It Works

The 5062C uses the inherent ability of cesium to reproduce a natural invariant resonance. A passive cesium resonator, the cesium beam tube, is used to excite and sense this resonance. The cesium beam tube serves as an atomic frequency reference and stabilizes the quartz oscillator in a frequency lock loop.

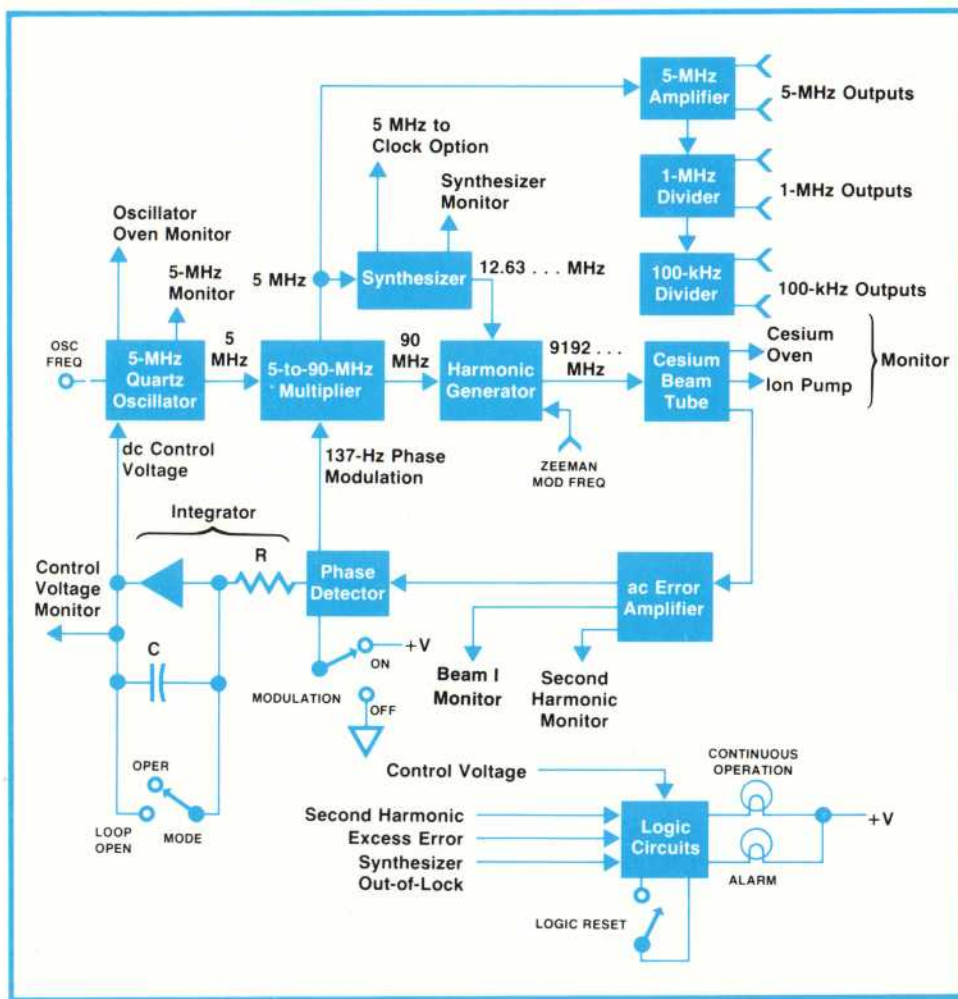

Fig. 4. The cesium beam tube is used as the frequency-determining element in a phase-locked loop that keeps a 5-MHz quartz oscillator precisely on frequency.

As shown in the block diagram, Fig. 4, a stable 5-MHz signal is generated by the voltage controlled 5-MHz quartz oscillator, multiplied to 90 MHz by the RF multiplier and applied to the harmonic generator, a step recovery diode, for multiplication to a frequency of 9180 MHz. This frequency is near the natural transition frequency of cesium, but isn't near enough to be used directly by the cesium beam tube. The exact frequency needed is 9192.63177 MHz. To reach this frequency a synthesizer takes 5 MHz from the multiplier and produces a frequency of 12.63177 MHz, which is then added to the 9180 MHz in the harmonic generator. The result is the required 9192.63177 MHz. This signal, when applied to the cesium beam tube, excites the highly stable cesium resonance. The cesium beam tube acts as a very high-Q resonator with a line width of 1260 Hz. Beam tube output current as a function of frequency is shown in Fig. 5a.

The 9192.63177-MHz input signal is frequency modulated at a 137-Hz rate. It sweeps across the beam tube resonance peak and creates the output signals shown in Fig. 5b. When the beam tube input signal is exactly at the cesium resonance frequency only the second harmonic component, 274 Hz, appears in the beam current output. If the input frequency is above or below the peak cesium resonance frequency, the beam current output contains 137-Hz components. The amplitudes and phases of these components determine the correction needed to tune the 5-MHz oscillator to zero frequency error.

Beam current signals from the beam tube are amplified by the ac error amplifier, which contains active filters that selectively amplify only the 137-Hz error signal. This then goes to the phase detector. The ac error amplifier also contains active filter circuits for the 274-Hz second harmonic signal, which is used to monitor proper operation of the instrument.

The 137-Hz signal from the ac error amplifier is synchronously demodulated by the phase detector to produce an average dc voltage whose amplitude is proportional to the amount of frequency error and whose polarity indicates whether the frequency is high or low. This dc error signal is applied to the integrator circuit. The integrator produces an error correction or control voltage that maintains the 5-MHz oscillator precisely on frequency.

The logic circuit monitors various signals within the instrument. In normal operation, the continuous operation lamp on the front panel is on. Should a malfunction occur, the continuous operation lamp goes out and the alarm lamp comes on. This condition is latched until the operator corrects the malfunction and resets the logic circuit. Thus temporary malfunctions cannot be overlooked. All power supplies in the instrument are of the high-efficiency switching regu-

lator type. An advantage of switching regulators over linear regulators is that their internal heat dissipation is nearly independent of supply voltage variations, thereby reducing this potential source of frequency instability.

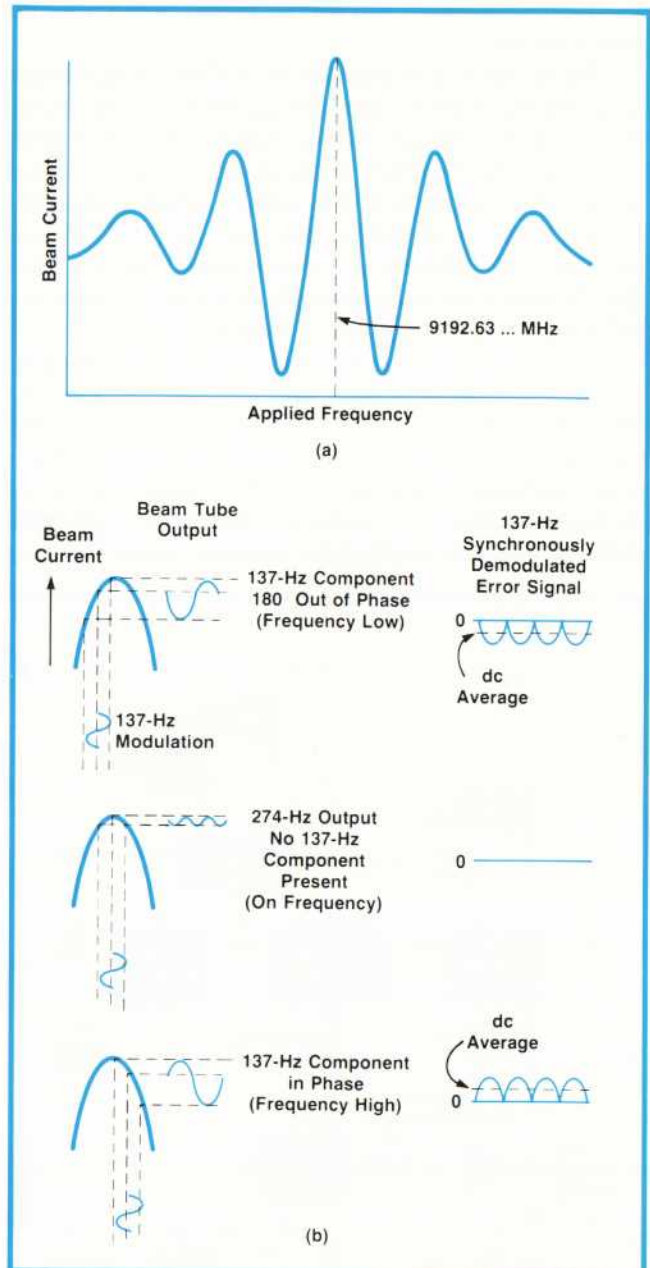

Fig. 5. (a) Cesium beam tube output current versus frequency. This is called the Ramsey pattern, after Professor Norman Ramsey of Harvard University, who first proposed a dual-cavity microwave structure, greatly alleviating certain problems of single-cavity structures. (b) The beam tube input signal is frequency modulated at a 137-Hz rate. When the input center frequency is at the peak of the cesium resonance, no 137-Hz component is present in the beam-tube output current, and vice versa. The 137-Hz component is detected to produce an error signal that is integrated and used to tune the quartz oscillator.

Environmental Performance

The 5062C has solid aluminum machined side frames. These help considerably to ruggedize the instrument for shock and vibration. Most card cages within the instrument are cast and form an integral part of the basic mechanical assembly. The cards that go into the card cages are manufactured to close mechanical tolerances and held in place by tight-fitting card guides to reduce resonances in the cards and the components mounted on them. All electrical components are rated at least to -30°C and in some cases from -55°C to $+125^{\circ}\text{C}$.

To make certain that the unit was indeed rugged and reliable several qualification tests were undertaken. Successful completion of these tests proved the 5062C meets the rugged environmental requirements commonly encountered in system specifications. The major areas tested were temperature, humidity, vibration, shock, RFI, and reliability. Humidity testing was done at $+50^{\circ}\text{C}$ and 95% relative humidity, with the specimen subjected to this environment for 15 days.

Two different shock tests were performed. The first was a nonoperational three-axis test using a 30-g, 11-ms, $\frac{1}{2}$ -sine-wave shock. The second test has been dubbed the "hammer blow" test, and involves striking a large steel carrier to which the instrument is strapped with a 180-kg (400-lb) hammer. The hammer swings through 30, 90, and 150-cm (1,3 and 5-ft) drops in each of three axes for a total of nine blows. The 150-cm drop generates shocks of typically 1500g for one microsecond. The hammer blow test was performed while the instrument was operational. The unit successfully passed both shock tests with neither mechanical nor electrical damage.

Perhaps the most demanding test was to prove reliability. It involved thermal cycling of four instruments between -28°C and $+65^{\circ}\text{C}$ every four hours, 10 minutes of 1-g vibration per hour, and cycling of the input power from high and low ac to high and low external dc to battery. This test lasted 14 days and

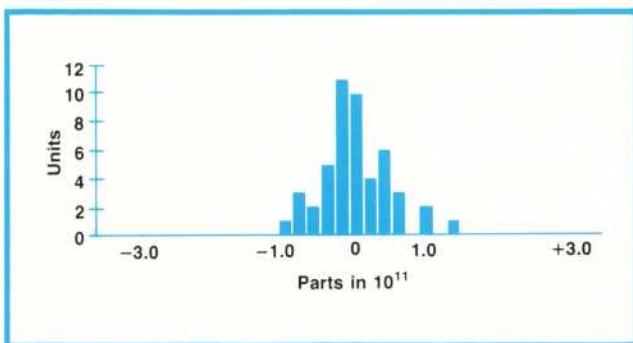

Fig. 6. Frequency comparison of 48 independently aligned 5062C Cesium Beam Frequency References.

demonstrated a mean time between failures (MTBF) of 2500 hours. Taking into account the acceleration factors involved due to the stress, the MTBF in an average situation will be far in excess of 2500 hours and should exceed that of previous HP cesium standards.

RFI, or radio frequency interference, is a critical factor when a unit must perform in a system along with other equipment. Two general areas need to be taken into account. Emitted interference from a unit must be of such a low level as to not interfere with the operation and accuracy of other units around it, and the susceptibility of a unit to emissions from other equipment must be low enough so the unit is not upset. MIL-STD-461A specifies a comprehensive testing method for RFI, and the 5062C meets the requirements of this specification.

Performance Data

The reason for using an atomic standard is to know frequency and time with a high degree of accuracy and stability. The accuracy specification for the 5062C is $\pm 3 \times 10^{-11}$ which includes thermal and magnetic field effects. In terms of frequency, this is $\pm 150 \mu\text{Hz}$ at 5 MHz, or in terms of time, ± 2.6 microseconds per day. Typical room-temperature accuracy

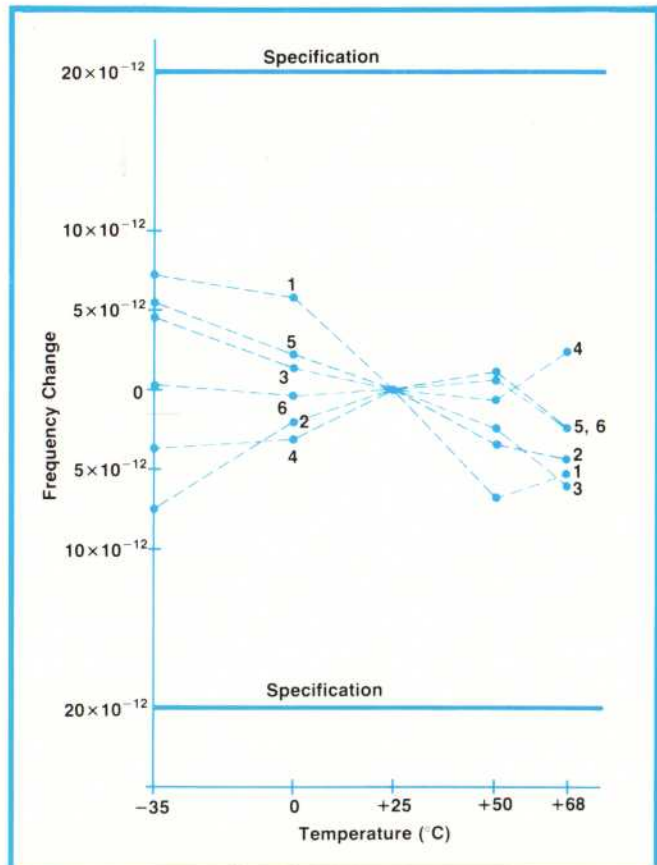

Fig. 7. Frequency versus temperature for six 5062C's.

for a number of units is shown in Fig. 6. Fig. 7 shows the results of temperature effects on a sample of instruments.

Long-term stability is specified to be $\pm 1 \times 10^{-11}$ exclusive of environmental effects. This long-term stability, which generally refers to measurement times exceeding one day, is what makes improved navigation and communication systems practical.

Although long-term stability is very important, many applications require good short-term stability or spectral purity. In the time domain, short-term stability is expressed as the standard deviation of the fractional frequency fluctuations as a function of measuring time. This definition requires that sample size, measurement bandwidth, and measurement dead times be specified.⁹ For measurement times shorter than the control loop time constant in the 5062C, the stability is determined by the precision 5-MHz quartz oscillator and amplifiers. For times greater than the loop time constant, the cesium beam resonator dominates until the flicker noise level is reached. Fig. 8 compares the specified short-term stability with typical performance for averaging times from 10^{-3} to 10^5 seconds.

Short-term stability for averaging times from one second to 10^4 seconds is inversely proportional to the figure of merit of the resonator. Fig. 9 compares typical figure-of-merit performance of 5062C cesium beam tubes with the specified end-of-life level. Fig. 8 compares this data with short-term behavior. The conservative end-of-life specification corresponds to a figure of merit of 1.2. The figure of merit remains nearly constant until near the end of a tube's life, at which time the background noise increases in the resonator.

In the frequency domain, stability is generally expressed as power spectral density or phase-noise-to-

carrier ratio. To be meaningful, a measurement bandwidth must be specified. The spectral purity can be separated into discrete components, spurious signals generated within the 5062C, and random perturbations due to noise in the oscillator and beam tube. The 5062C is specified to have non-harmonic spurious signals at least 80 dB down from the carrier. Typically, these are down more than 100 dB. Fig. 10 compares the phase noise performance to specifications.

Stability can be an important performance parameter if something better than specified accuracy is desired. The 5062C has a stability range well in excess of the specified $\pm 3 \times 10^{-11}$ accuracy. The resolution is approximately 1×10^{-12} .

An important concern for a portable instrument is its performance in the presence of changing magnetic fields, especially the earth's magnetic field. The unit has been designed to reduce this effect to a negligible value, typically 1×10^{-13} for a 1-gauss change, equivalent to a worst-case reorientation in the earth's field.

Gravitational variations are not of major concern. The quartz oscillator is the only gravity-sensitive component in the unit, and its output is controlled by circuits that compensate for changes in output frequency.

Serviceability

The 5062C has been designed for ease of servicing. Many circuits are monitored by a front-panel meter, often allowing fault diagnosis to the module level without any other test instruments. For internal troubleshooting, many key test points are provided, and most internal troubleshooting can be done with only a voltmeter. Most of the internal modules simply plug in and each is keyed so it cannot be inserted in the wrong slot or inserted backwards. Module handles are color coded for easy identification.

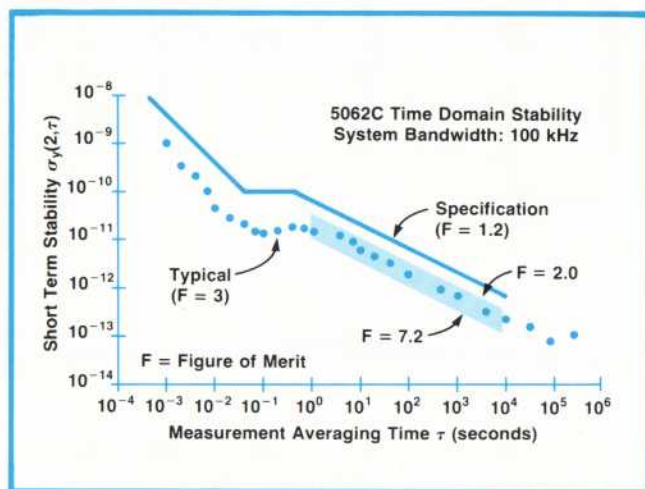

Fig. 8. Typical 5062C short-term stability compared to specifications.

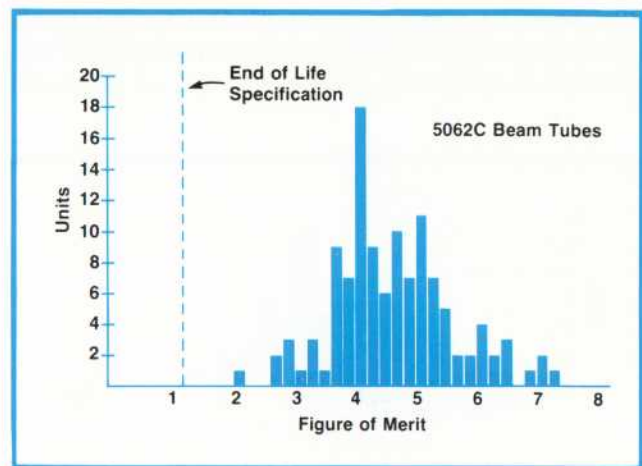

Fig. 9. Figure of merit performance of 5062C's compared to specified end-of-life performance. Figure of merit remains nearly constant until end of life is near.

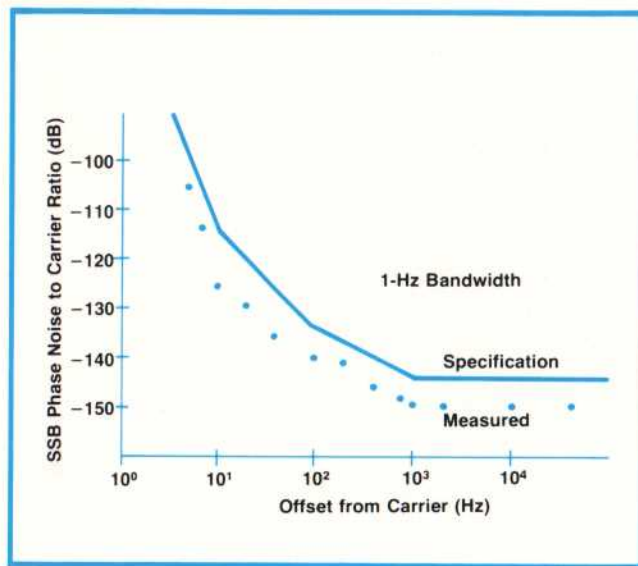

Fig. 10. Typical 5062C phase noise performance.

Drawings showing key internal test points and module locations are silkscreened on the insides of the top and bottom covers.

Safety in troubleshooting and repair was one of the prime concerns of the design team. All dangerous voltages are covered and high-voltage labels warn the technician that potentially dangerous voltages are present. The high-voltage power supplies are in sealed cans with safety-type high-voltage connectors.

Clock and Battery Options

With the digital clock option installed, precise time can be maintained and displayed. This option generates a reference 1-pps and an adjustable 1-pps output, the latter separately buffered to the front and rear panels. The adjustable outputs can be shifted in time with respect to the 1-pps reference output by means of a front-panel thumbwheel switch that has a resolution of 100 ns. This allows an operator to compare some other 1-pps signal with the advanced 1-pps signal from the 5062C; by dialing in the amount of time needed to make these two pulses coincide the operator can directly read on the thumbwheel switches the time difference between the two signals. The 24-hour clock display can be set to any time, and hours, and minutes, or seconds can be added to or subtracted from the display while maintaining the time-of-day readout. The internal divider chain that divides 5 MHz down to 1 pps can be synchronized with an external 1-pps signal to within ± 500 ns. Other capabilities, such as UTC step (leap second) and optional time code output, give the instrument a great deal of versatility in timekeeping.

The optional internal gelled lead-acid batteries provide a one-hour standby time. Charging is automatic when connected to an ac power source and a front-

panel indication is given when the battery is in a high state of charge. A "battery available" lamp on the front panel tells the operator when battery standby power is available. Should a battery malfunction occur this lamp will not be lit. The instrument will automatically go on batteries whenever the ac line voltage drops enough to cause the unregulated dc to drop below 24 volts, or when the external dc drops to 22 volts. This crossover between ac, external dc, and internal battery is fully automatic; the operator need not intervene in the event of a power failure.

Acknowledgments

A large number of people have contributed to this project. The initial design work on the small cesium resonator was done at HP's Frequency and Time Division East in Beverly, Massachusetts, prior to its incorporation into the Santa Clara Division. The late Joseph Holloway led the development effort on the cesium beam resonator. Len Cutler, presently HP Physical Research Laboratory Director, was manager of the F&T East facility and made many technical contributions to the resonator. Richard Lacey of HP Laboratories provided many valuable theoretical calculations. Lou Mueller participated in the resonator development and instrument interface. The instrument development team was led by Darwin Throne during the CAS prototype development. Design engineers included Jim Koch, Rob Burgoon, Rex Brush, Jack Elmberg, Ed Weal, and Hank Fallek. The producibility of the cesium beam resonator was enhanced by the contributions of Dominick de Simone and Ernie Riberdy.

References

1. B.E. Blair et al., "Time and Frequency: Theory and Fundamentals," NBS Monograph 140, National Bureau of Standards, U.S. Department of Commerce, May 1974.
2. A.S. Bagley and L.S. Cutler, "A New Performance of the 'Flying Clock' Experiment," Hewlett-Packard Journal, July 1964.
3. L.N. Bodily, "Correlating Time from Europe to Asia with Flying Clocks," Hewlett-Packard Journal, April 1965.
4. L.N. Bodily, D. Hartke, and R.C. Hyatt, "World-Wide Time Synchronization, 1966," Hewlett-Packard Journal, August 1966.
5. L.N. Bodily and R.C. Hyatt, "Flying Clock Comparisons Extended to East Europe, Africa and Australia," Hewlett-Packard Journal, December 1967.
6. L.N. Bodily, "A Summary of Some Performance Characteristics of a Large Sample of Cesium-Beam Frequency Standards," Hewlett-Packard Journal, October 1966.
7. R.C. Hyatt, L.F. Mueller, and T.N. Osterdock, "A High-Performance Beam Tube for Cesium Beam Frequency Standards," Hewlett-Packard Journal, September 1973.
8. R.F. Lacey, A.L. Helgesson, and J.H. Holloway, "Short-Term Stability of Passive Atomic Frequency Standards," Proceedings of the IEEE, Vol. 54, No. 2, February 1966.

9. J.A. Barnes et al., "Characterization of Frequency Stability," NBS Technical Note 394, National Bureau of Standards, U.S. Department of Commerce, October 1970.



Charles E. Heger

Chuck Heger was responsible for the final design of several modules in the 5062C Cesium Beam Frequency Reference, and became project leader in 1972. He began his electronics career as a U.S. Navy technician from 1962 to 1965, then worked on board a civilian missile tracking ship, a job that took him around the world. Next came college and part-time electronics work for several small companies. He joined HP in December 1971 and received his BSEE degree from

San Jose State University a month later. Chuck was born in Ellensburg, Washington. Among his interests are woodworking, flying, fishing, gardening, and designing and building high-fidelity audio equipment. He and his wife, who works in quality assurance at another HP division, live in Campbell, California.



Gary A. Seavey

Gary Seavey has been developing beam tubes for HP for thirteen years, starting as a technician in 1963. He received his BS degree in physics from the University of Santa Clara in 1971, and is presently studying for his MBA degree at Santa Clara. He's a member of IEEE. Born in North Conway, New Hampshire, Gary is married, has two children, and lives in Cupertino, California. Skiing, swimming, and tennis are his major recreational activities.



Ronald C. Hyatt

Ron Hyatt is manager of precision frequency sources at HP's Santa Clara Division. He's been with HP since 1964, serving as development engineer, project manager, and section manager on the way to his present position. He's a veteran of two HP flying clock trips, in 1966 and 1967. Ron earned his BSEE degree in 1962 from Texas Technological University and his MSEE in 1963 from Stanford University. He's an amateur astronomer, a backpacker, and a youth soccer coach, and is active in the local YMCA. He and his wife and two sons live in Los Altos, California.

SPECIFICATIONS

HP Model 5062C Cesium Beam Frequency Reference

ELECTRICAL

ACCURACY: $\pm 3 \times 10^{-11}$, maintained over a temperature range of -28° to $+65^\circ\text{C}$ and magnetic fields up to 0.2 millitesla (2 gauss) peak.
REPRODUCIBILITY: $\pm 1 \times 10^{-11}$
SETTLABILITY (Frequency): $\pm 2 \times 10^{-12}$
LONG-TERM STABILITY (for the life of the cesium beam tube): $\pm 1 \times 10^{-11}$
SHORT-TERM STABILITY (5 MHz):*

Averaging Time (sec.)	$\sigma_{\Delta f/f}(2,\tau)$
.001	4×10^{-9}
.01	4×10^{-10}
.1	1×10^{-10}
1	7×10^{-11}
10	2.2×10^{-11}
100	7×10^{-12}
1,000	2.2×10^{-12}

SSB PHASE NOISE (5 MHz):*

Offset from Signal	Phase Noise (1 Hz BW)
Hz	dB
10 ⁻³	6
10 ⁻²	26
10 ⁻¹	46
10 ⁰	74
10 ¹	114
10 ²	134
10 ³	144
10 ⁴	144

*Some degradation when subjected to vibration or ac magnetic fields.
WARM-UP TIME: 20 minutes from -28°C

SINUSOIDAL OUTPUTS: 5 MHz, 1 MHz, and 100 kHz; front and rear panel BNC, individually buffered
OUTPUT VOLTAGE: 1 to 1.5V rms into 50 ohms
HARMONIC DISTORTION: down more than 40 dB from rated output
NON-HARMONICALLY RELATED OUTPUT: down more than 80 dB from rated output, 80 dB under vibration or ac magnetic field

SIGNAL-TO-PHASE-NOISE RATIO: For 5 MHz and 1 MHz outputs, >87 dB at rated output in a 30 kHz noise bandwidth (1 Hz centered on carrier rejected), >60 dB with magnetic fields or vibration as specified in ENVIRONMENTAL.
ISOLATION: No degradation below specified performance by short-circuit on any other output.

QUARTZ OSCILLATOR:

AGING RATE: $<5 \times 10^{-10}$ per 24 hours
COARSE FREQUENCY ADJUSTMENT RANGE: $>1 \times 10^{-6}$

ENVIRONMENTAL:

TEMPERATURE: without Options (MIL-E-16400F, Class 2):
 Operating: -28° to $+65^\circ\text{C}$. Frequency change $<2 \times 10^{-11}$ with respect to frequency at 25°C .
 Non-operating: -62° to $+75^\circ\text{C}$. The ion pump must be operated continuously for extended storage above 35°C or periodically at lower storage temperatures.
HUMIDITY: Operating range, 95% humidity -28° to $+65^\circ\text{C}$. Frequency change $<1 \times 10^{-11}$ from -28° to $+50^\circ\text{C}$ with respect to frequency at 25°C , 50% humidity.

ALTITUDE: frequency change 0 to 15.2 km (50,000 ft), $<5 \times 10^{-12}$
MAGNETIC FIELD: 0-0.2 millitesla (0-2 gauss) dc or peak ac at 50, 60 and 400 Hz; frequency change less than 2×10^{-12} . No permanent damage while operating in magnetizing fields of 2000 ampere-turns/meter (25 oersteds) dc to 1 Hz.
VIBRATION: MIL-E-16400F (MIL-STD-167-1, Type 1), 4 to 50 Hz, 1.3g, maximum. Frequency shift $<2 \times 10^{-11}$ during vibration.
SHOCK: MIL-S-901C for Class 1, Grade A, Type A equipment; 400 lb hammer blow, 1.3, and 5 ft drop in 3 axes

OPTION 001 DIGITAL CLOCK: Digital dividers generate 1 pulse-per-second from 5 MHz. This master pulse may be synchronized to a reference input pulse. The digital clock and the clock 1 pps are adjustable in phase with respect to the master pulse.

PULSE OUTPUTS:

1 pps: Rear Panel BNC
 1 pps: Front and Rear Panel BNC
 Jitter: Phase jitter with respect to 5 MHz, <5 ns rms (excluding environmental effects).

SYNCHRONIZATION: Automatic. Master pulse synchronized to external reference pulse to within ± 500 ns. Reference pulse must be ± 4 to ± 10 V amplitude, <50 ns rise-time and 500 ns minimum width.

CLOCK 1 PPS ADVANCE: Adjustment range of front-panel thumbwheel switches: 0.1 μs to 1 s (999,999.9 μs) advance with respect to the master.
UTC STEP: Deletes a 1-second pulse for leap-second adjustment.
24-HOUR CLOCK DISPLAY: Solid state digital hours, minutes, seconds driven by Clock Pulse. Normally lighted. Push-to-read button for readout when on standby battery or external dc.

OPTION 002 STANDBY BATTERY

STANDBY TIME: >1 hour at 25°C ; >20 minutes at -28°C and >30 minutes at $+55^\circ\text{C}$ after full charge at 25°C .
RECHARGE: Automatic fast charge and float charge after fully charged. Charging time from full discharge, 16 hours at 25°C .

OPTION 010 TIME-CODE GENERATOR

Time-code generator and digital clock, 5 MHz distribution amplifier, timing fault signal, Option 002 Battery. Meets requirements of Military Specification MIL-F-28811(EG), Military Nomenclature, Frequency Standard, Cesium Beam 0-1695U.

GENERAL

WARRANTY: 1 year
TUBE SHELF LIFE: For a new tube full operating life is expected after 2 years storage in temperatures up to 35°C , if stored according to recommended procedures.

DIMENSIONS: 133 mm (5-7/32 in) high, 425 mm (16-3/4 in) wide (19 in standard rack mounting slot panel), 521 mm (20-1/2 in) deep behind front panel.
WEIGHT: 5062C (basic instrument), 22.7 kg (50 lb); Option 001 (add), 2.3 (5 lb); Option 002 (add), 6.8 kg (15 lb); Option 003 (add), 9.1 kg (20 lb); Option 010 (add), 9.1 kg (20 lb).

POWER: 115V or 230V ac $\pm 10\%$, 50, 60, or 400 Hz $\pm 10\%$ or 22V to 30V dc.
 Option 010 has a power ON-OFF switch.

PRICES IN U.S.A.:

HP Model 5062C, \$16,950
 Option 001 Clock, \$2,100
 Option 002 Battery, \$1,000
 Option 003 Clock and Battery, \$3,100
 Option 010 Time Code Generator, \$4,800

MANUFACTURING DIVISION: SANTA CLARA DIVISION
 5301 Stevens Creek Boulevard
 Santa Clara, California 95050 U.S.A.

Calibrated FM, Crystal Stability, and Counter Resolution for a Low-Cost Signal Generator

A new synchronizer/counter boosts the frequency stability and resolution of HP's low-cost 520-MHz signal generator, which is now available in a new calibrated-FM version, Model 8654B, as well as the original Model 8654A.

by Robert R. Collison and Ronald E. Kmetovicz

LOW-COST, MECHANICALLY TUNED signal generators are useful tools in a wide range of applications, from receiver testing to general use in schools, research and development laboratories, field service, and production. In many applications the continuous tuning feature of these generators is desirable, the only drawback being that typically there is only an analog frequency display—a dial—which for some test situations lacks sufficient accuracy and resolution. In such situations a frequency counter is often used to measure the output frequency, sometimes introducing another problem: radio frequency interference (RFI).

Another common characteristic of low-cost signal generators is that their frequency drift rate is too high for some applications. A frequency synchronizer solves this problem by phase-locking the signal generator to a more stable crystal oscillator.

Synchronizer/Counter

The basic functional diagrams of a synchronizer and a counter are similar in many respects, and now there is a single instrument that performs both functions. Model 8655A Synchronizer/Counter works with HP's low-cost 10-to-520-MHz Model 8654A¹ and 8654B Signal Generators (see Fig. 1). Model 8654B is also new; it adds well calibrated frequency modulation to the features of the 8654A (more about this later).

The synchronizer/counter provides an accurate digital display of the signal generator output frequency and reduces frequency drift while retaining all of the performance features of the signal generator. The output frequency is displayed with a resolution of 1 kHz (100 Hz in $\times 10$ expand) to an accuracy of ± 2 ppm (± 0.3 ppm with Option 001). With the push of a single button, frequency drift is reduced to less than 0.1 ppm/hour; frequency lock resolution is 500 Hz. As



Fig. 1. Model 8655A Synchronizer/Counter (top) provides crystal stability and a high-resolution readout for the 8654A and 8654B Signal Generators. Model 8654B (bottom) has all of the capabilities of the 8654A plus calibrated FM.

shown in Fig. 1, the system is compact and portable and controls are arranged for operator convenience.

The synchronizer/counter is designed for applications in which radiated interference from a frequency counter may be harmful to the measurement. Careful attention has been given to minimizing RF emissions. Semi-rigid coaxial cable connects the type-N RF inputs to a fully shielded RF subassembly. This shielded module contains all the high-speed circuits and the LED displays. In addition to the shielding provided by the assembly, all input/output lines are filtered, RF gaskets are installed in critical areas, and aluminum honeycomb air ducts are used. As a result, radiation from the unit is less than $1.5 \mu\text{V}$ as measured with a 50Ω receiver and a two-turn, one-inch loop held one inch from any surface.

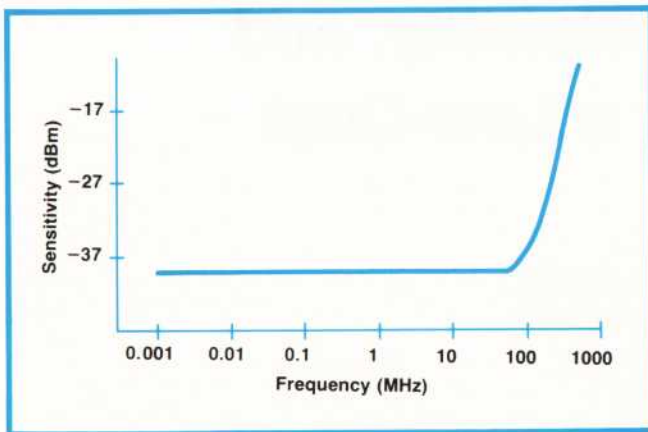

Fig. 2. Typical 8655A counter sensitivity as a function of frequency.

System Operation

The operating mode of the 8655A Synchronizer/counter is selected by the push of a button. There are three count modes: external 0.001-10 MHz, external 10-520 MHz, and synchronize count. The resolution in any count mode may be expanded by a factor of 10. Depressing an EXT COUNT button (either 0.001-10 MHz or 10-520 MHz) selects the type-N front panel count input. The frequency of the signal applied to this port is counted and displayed with a resolution as fine as 1 Hz.

Typical sensitivity as a function of frequency is shown in Fig. 2. The input circuits are tolerant to high-level signals: when the input power level approaches approximately 0.2 watt, an RF fuse burns out, protecting the counter front-end circuits.

For operation as a synchronizer, semi-rigid coaxial

cable connects the signal generator rear-panel RF auxiliary output to the synchronizer/counter rear-panel RF input. The phase error correction signal from the synchronizer/counter is supplied to the signal generator by means of a cable from the rear panel of the synchronizer/counter to the rear-panel ϕ -lock input on the 8654B rear panel or to the external FM input of the 8654A. A slide switch inside the synchronizer/counter selects the appropriate interface circuit for the 8654A or B.

To operate the system, the SYNCHRONIZE COUNT pushbutton is depressed. The synchronizer/counter then counts and displays the signal generator output frequency. Tuning the generator to the desired output frequency and then depressing the LOCK pushbutton phase locks the generator output frequency to the synchronizer/counter's crystal timebase with a resolution of 500 Hz. Depressing the LOCK +500 HZ pushbutton increments the locked frequency by 500 Hz, a useful feature where communication channels are spaced at 12.5-kHz intervals. A flashing display on the synchronizer/counter indicates when it is necessary to retune the signal generator to the desired frequency and relock the system. Readers familiar with the HP 8640B Signal Generator² will note its similarity in operation to the 8655A/8654AB system.

The Counter

Conventional techniques were used to implement the count function, as shown in Fig. 3. The applied signal enters through one of the 50 Ω count inputs and passes through the RF fuse to the limiter. Limiting action occurs when signal levels are greater than +7

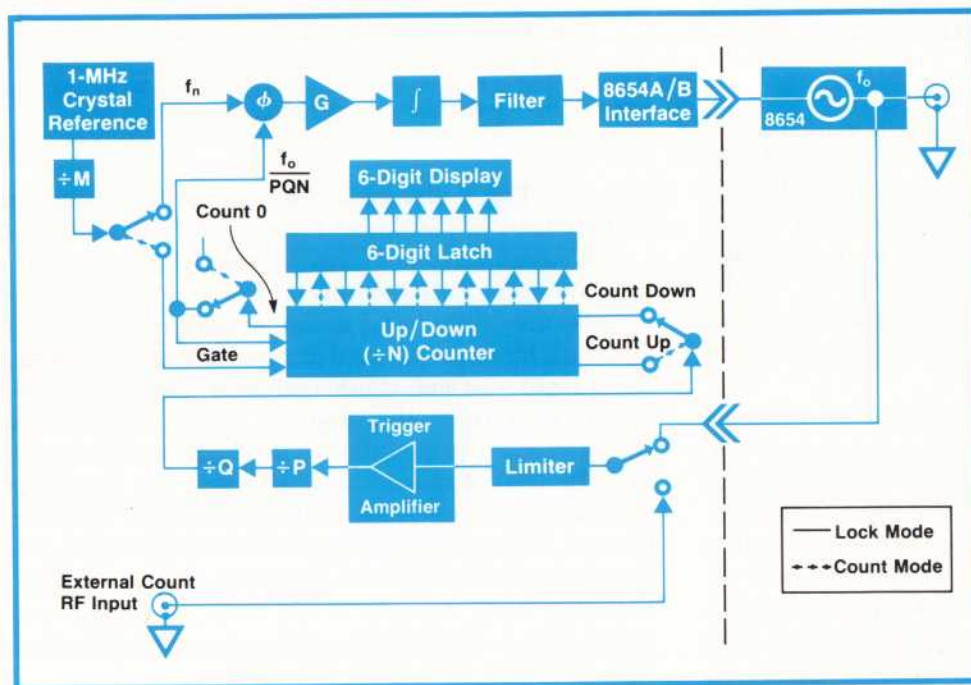

Fig. 3. Functional block diagram of the 8655A Synchronizer/Counter.

dBm to shape and restrict the level of the signal applied to the trigger/amplifier. The trigger/amplifier, $\div P$, and $\div Q$ functions are realized using direct-coupled, high-speed logic elements to produce a frequency divider that operates with input signal levels of less than -7 dBm at frequencies that may exceed 520 MHz. The divider input frequency is supplied to the up/down counter (operating in the up count mode), which is gated by a timing signal derived from a 1-MHz crystal reference to produce a six-digit display of the input frequency. Numerical values for P, Q, and M are 1, 1, and 10,000 in the 0.001-10 MHz mode and 64, 1, and 64,000 in the 10-520 MHz mode. For the expand function, M is multiplied by 10.

The Synchronizer

Synchronization is accomplished by a phase locked loop, partly in the synchronizer/counter and partly in the signal generator (Fig. 3). In the locked mode, $M = 64,000$, $P = 64$, and $Q = 1$ (normal lock) or $Q = (N+0.5)/N$ (lock +500 Hz), where N is a number representing the signal generator output frequency f_o in kHz ($10000 \leq N \leq 520000$ over the operating frequency range of 10 to 520 MHz). When a lock push-button is depressed, the up/down counter completes its count up cycle, leaving N stored in the six-digit latch. The counter then enters a free-running (not controlled by the time base) count down cycle. Division by N is accomplished by programming the counter to the count stored in the latch, counting down to essentially 0, and then continually repeating the process.

The phase of the "count 0" signal is compared to that of the reference by the phase detector. The phase detector output is then amplified, integrated, filtered, and translated to provide an error correction signal to the signal generator.

Incrementing the locked frequency by 500 Hz is accomplished using fractional division techniques. In Fig. 4, the circuit for division by PQ is shown in greater detail. The frequency of the applied RF signal is divided by 32 ahead of the pulse swallower. In the normal lock mode, the pulse swallower is inactive

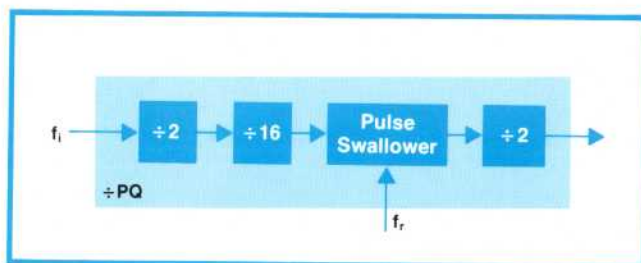

Fig. 4. 8655A $\div PQ$ circuit. The pulse swallower is operational only in the lock +500 Hz mode. This mode is useful in testing communications systems where channels are spaced at 12.5-kHz intervals.

and the signal leaves the $\div PQ$ element at a frequency of $f_i/64$. The number of pulses in the reference time interval, $T = 1/f_r$, is $Tf_r/64$. With the pulse swallower operational, one pulse from the $f_i/32$ pulse train is removed over the time interval T; therefore, the number of pulses at the output is $Tf_r/64 - 1/2$. But $f_i = f_o$ in the normal lock mode and $f_i = f_o + 500$ Hz in the lock +500 Hz mode, so the frequency of the output of the $\div PQ$ element is unchanged between the two modes. This is equivalent to division by $(N+0.5)/N$.

Reliability and Maintainability

Careful consideration was given to component selection in the design of the 8655A. Whenever possible, only materials that have demonstrated superior long-life performance in actual field use are used. In many cases, entire functional blocks are based on similar circuits of known reliability from previous Hewlett-Packard products. The internal temperature rise of the unit was minimized to improve reliability primarily by component selection and application, by optimizing conduction heat flow paths, and by forced-air cooling of enclosed compartments. The design is expected to have a mean-time-between-failures in excess of 10,000 hours.

The 8655A was designed to minimize the time associated with normal maintenance and thereby reduce its total cost of ownership. Only one easily accessible adjustment is recommended on a periodic (90 day) basis. Should a fault develop within the unit, the operator can apply a diagnostic algorithm supplied with the instrument to isolate the problem to one of five functional areas without the use of any additional test equipment. The unit can then be configured in its service operating mode (Fig. 5) to locate and repair the fault. In the service mode, all compo-

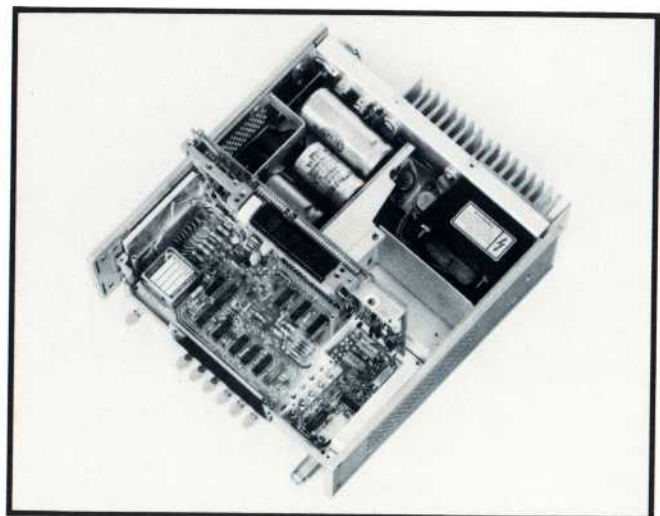

Fig. 5. In the service operating mode all components of the 8655A are observable by the technician and the unit is fully operational.

nents are observable by the test technician.

New Calibrated-FM Signal Generator

A particularly useful feature of a low-cost VHF signal generator is calibrated frequency modulation. Tests of narrow-band FM receivers require a signal generator that has well calibrated, low-noise, and low-distortion FM as well as good RF signal spectral purity and precise settability because of the narrow receiver channel widths. Such tests usually require peak deviations of less than 10 kHz at standard rates of 400 Hz or 1000 Hz. Tests of home entertainment receivers require larger peak FM deviation—on the order of 75 kHz—as well as an external frequency modulation input for frequency response tests. Slow frequency sweeps of narrow-band RF amplifiers and filters are aided by dc-coupled FM and continuously adjustable center frequency.

The new Model 8654B Signal Generator is designed to meet these requirements. The 8654B has all the capabilities of its predecessor, Model 8654A,¹ plus continuously adjustable metered FM in four peak deviation ranges of 3 kHz, 10 kHz, 30 kHz, and 100 kHz.

The 8654AB Signal Generators have solid-state capacitively tuned LC oscillators that tune from 10 MHz to 520 MHz. Compared with resonant cavity oscillators, these LC oscillators have higher noise because of lower resonator Q, but are less costly. Fig. 6 shows typical 8654B RF phase noise performance. In the FM OFF position, 8654B phase noise is essentially the same as the 8654A's. This amount of noise will allow most narrow-band FM receiver tests, such as usable sensitivity, quieting sensitivity, and spurious

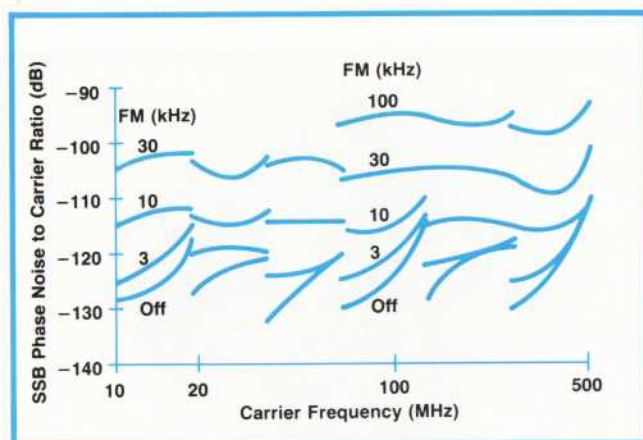

Fig. 6. Typical 8654B phase noise performance, shown as SSB signal-to-noise ratio in a 1-Hz bandwidth 20 kHz away from the carrier. Carrier power is +3 dBm. With FM off, phase noise is similar to that of the 8654A (see ref. 1). With the FM switch in the EXT position, phase noise degrades because of FM modulator noise. At an output power of -7 dBm, noise degrades typically less than 6 dB.

attenuation. For some other tests, such as adjacent channel rejection, the lower phase noise of a resonant cavity oscillator such as the HP 8640B is necessary.

The 8654B has essentially none of the spurious signals (other than line-related) that inevitably occur in synthesized signal generators. Typical synthesizer spurious signal specifications of around -70 dB do not allow tests of narrow-band FM receiver spurious attenuation, which is typically around -85 dB. Intermodulation spurious tests are also impossible when synthesizer spurious signals enter directly into the passband of the receiver under test. The 8654B can perform these tests of FM receivers.

Design for Calibrated FM

The RF frequency in the 8654AB is selected by means of six band-switched inductors in parallel with a tuning capacitor. Frequency modulation and electrical fine tuning are achieved by changing the reverse bias voltage across varactor diodes that are coupled in parallel with the RF oscillator tank circuit (Fig. 7). Electrical fine tuning helps the user adjust the RF frequency into the passband of narrow-band FM receivers.

To achieve calibrated FM using varactor diodes in parallel with a capacitively tuned LC oscillator, the drive voltage across the diodes must be adjusted according to the RF frequency.¹ The resonant frequency of an LC tank circuit is $f = (2\pi\sqrt{LC})^{-1}$. The frequency sensitivity to capacitance change is, for small $\Delta C/C$:

$$\frac{\Delta f}{f} = -\frac{1}{2} \left(\frac{\Delta C}{C} \right) \quad (1)$$

where C is the total capacitance of the tuning capacitor and the varactor diodes.

For the varactor diodes used in the 8654B, capacitance is related to total reverse bias voltage across the diodes by the nonlinear relationship:

$$C_v = \frac{C_o}{(V_R - V_o)^N} \quad (2)$$

where C_v is varactor diode capacitance, C_o is a capacitance constant, V_R is the dc reverse bias voltage, and V_o is the ac drive voltage (average dc value = 0). $(V_R - V_o)$ is the total reverse bias across the varactor diodes. N is a constant ranging from 0.3 to 0.5, depending on the diode construction.

Uncompensated, the resulting frequency dependence on varactor diode audio drive voltage is, assuming $N = 0.5$:

$$\Delta f = [K_1 f^3 (V_R - V_o)^{-3/2}] V_o \quad (3)$$

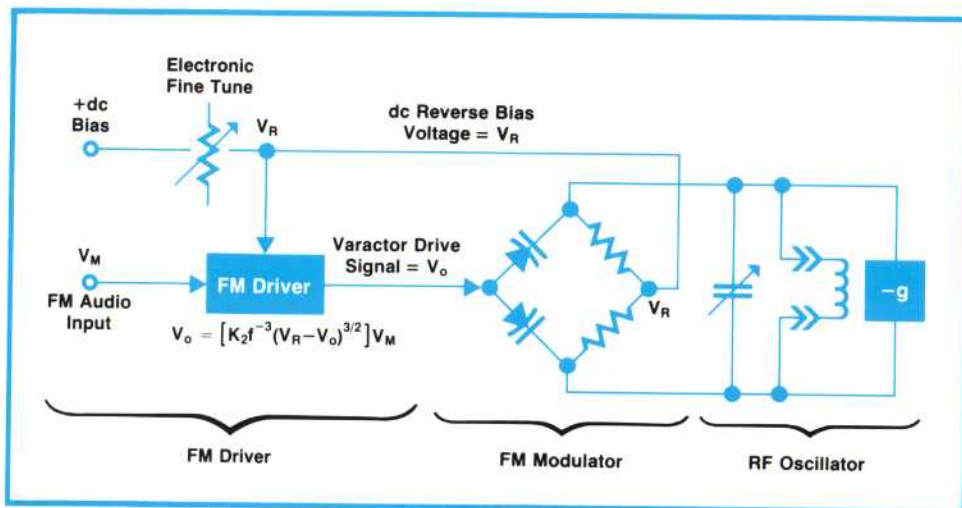

Fig. 7. Model 8654B Signal Generator frequency modulation circuits. FM and electrical fine tuning are accomplished by changing the reverse bias voltage across varactor diodes in parallel with the RF oscillator tank circuit.

where K_1 is a constant depending on the inductor in the oscillator.

The f^3 term represents the fact that approaching the high-frequency end of the tuning capacitor range, the varactor diode capacitance is an increasingly larger percentage of the total tank capacitance, thus increasing the FM sensitivity.

The $(V_R - V_o)^{-3/2}$ term represents the nonlinear dynamic-capacitance-versus-reverse-bias-voltage characteristic of the varactor diodes. This term also represents FM distortion, since the desired frequency change Δf is not a linear function of the varactor diode drive voltage V_o . To linearize Δf as a function of f and V_o , the 8654B employs an FM driver amplifier that provides an inverse gain function of:

$$V_o = [K_2 f^{-3} (V_R - V_o)^{3/2}] V_M \quad (4)$$

where

$$K_2 = \frac{1}{K_1} \times (\text{selected FM range constant})$$

and V_M is the FM modulation input signal to the FM driver. V_M comes either from the internal audio oscillator or from an external source. The result of multiplying equations 3 and 4 is:

$$\Delta f = (\text{selected FM range constant}) \times V_M. \quad (5)$$

The FM range constant is selected by means of a front-panel switch that changes the gain of the modulator. As equation 5 shows, frequency change is a linear function of modulation voltage, representing low-distortion FM. Since the 8654B FM driver is a dc amplifier, FM at very low rates, such as slow frequency sweeping, is possible.

FM Driver Design

To synthesize the FM driver gain equation (4)

several design approaches were considered. One method considered was to program a read-only memory to provide the f^{-3} gain information. However, address information would have had to come from some analog voltage representing frequency, since the 8654B has no built-in counter. Also, the ROM approach would not have eliminated the need for dynamic compensation of the nonlinear capacitance-versus-voltage characteristics of the varactor diodes and the ROM would have had to be programmed at the factory, making field adjustments impossible. For these reasons this approach was discarded.

The method chosen for the 8654B FM driver is to model the required gain equation using logarithmic and exponential amplifiers (Fig. 8).

The FM driver gain equation can be manipulated into an equivalent log-exponential form:

$$V_o = K_2 \exp[-3 \ln f + \frac{3}{2} \ln (V_R - V_o)] V_M \quad (6)$$

The “-3” term (“exponent” in Fig. 8) is actually a selected value for each band, on the order of -2 to -4. The variation is caused by stray capacitance and inductance in the oscillator circuit. The K_2 term (“gain” in Fig. 8) includes the K_1 term and is also selected for each RF frequency band. K_2 includes the FM range constant mentioned previously.

The $3/2$ term (“distortion” in Fig. 8) is also slightly adjustable because of variations in varactor diode capacitance-versus-voltage characteristics. This term represents the linearization of frequency change versus modulation voltage, as mentioned previously; it is adjusted for minimum FM distortion. This adjustment affects mainly second-harmonic FM distortion since the nonlinear varactor diode characteristics generate predominately second harmonics.

An advantage of the log-exponential amplifier approach is that even though the dc reverse bias across the varactor diodes (V_R) may be changed for each

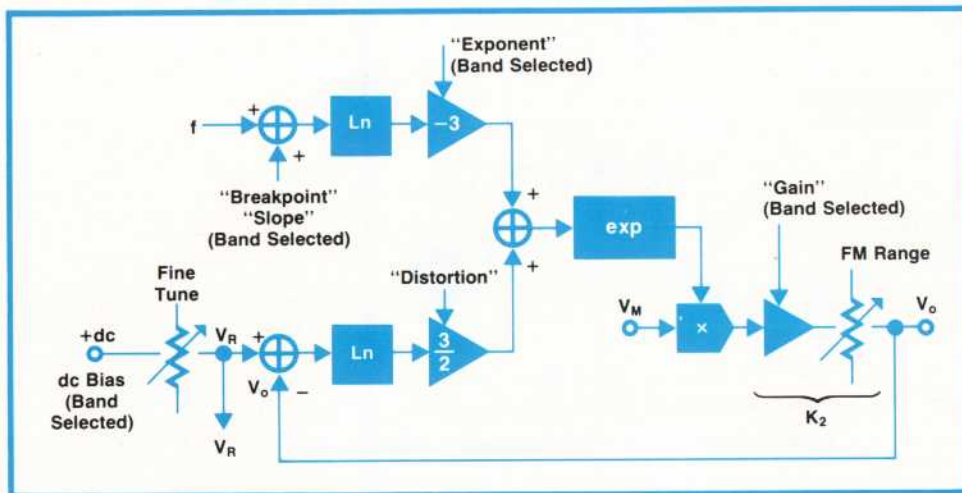

Fig. 8. The 8654B's FM driver circuit provides low-distortion FM by compensating for the non-linearity of the varactor diodes. Logarithmic and exponential amplifiers are used to control the modulator gain for calibrated FM.

RF frequency band to minimize RF phase noise, or may be slightly adjusted for electrical fine tuning, the FM distortion adjustment is not affected. The RF center frequency information is derived from the voltage on the wiper of a frequency sample potentiometer that is ganged to the tuning capacitor shaft. Each of the RF frequency bands is approximately an octave, or 2 to 1 in tuning range. Similarly, the voltages at the ends of the frequency sample potentiometer are in a 2 to 1 ratio and are therefore approximately proportional to RF frequency. The proportionality constant between the actual RF frequency and the sample voltage is accounted for in the gain (K_2) adjustment for each RF band.

In practice, the proportionality of the frequency sample voltage to the RF frequency breaks down at the low-frequency end of each band, where the tuning capacitor provides slightly smaller RF frequency change for a given angular shaft rotation than throughout the rest of the band. To correct for this error, separate correction factors ("breakpoint" and "slope" in Fig. 8) are added to produce the electrical effect of slowing the rotation of the frequency sample potentiometer.

The FM range selection switch has a dual purpose. Its first function is to give the user a choice of FM peak deviations. The second function is to reduce residual FM noise that might be introduced by the FM driver amplifier when using small FM deviations. On the 3-kHz and 10-kHz FM ranges, 10-dB and 20-dB attenuators, respectively, are connected to the output of the amplifier in the FM driver, thus reducing its noise contribution by the same amounts. When the instrument is in the FM OFF configuration, the drive voltage to the varicaps (V_o) is capacitively shunted to ground, allowing only the dc component of the FM driver output to reach the varicaps. This eliminates RF frequency jump when going into the FM mode from the FM OFF configuration. It also shunts FM driver noise

to ground when FM is not being used.

FM Specifications

FM harmonic distortion is specified at less than 2% for peak deviations up to 30 kHz and less than 3% for peak deviations up to 100 kHz. Although harmonic distortion is specified only for 400 Hz and 1000 Hz rates, the specifications are typical for all modulation rates from dc to 20 kHz.

The external FM sensitivity specification is 1 volt peak for maximum deviation indicated on the front-panel meter with the FM level control in the full clockwise position. Full scale on the front-panel meter is 3.16 kHz, 10 kHz, 31.6 kHz, or 100 kHz peak deviation, depending on the FM range setting. Indicated FM accuracy, as read on the front-panel meter, is $\pm(10\%$ of reading + 3% of full scale). For the 100-kHz FM deviation range above 130 MHz, an additional 3% is added to the external sensitivity and indicated accuracy specifications.

The 8654B is capable of 100-kHz peak deviation for all RF frequencies above 80 MHz and 30-kHz peak deviations for all RF frequencies. FM bandwidth is dc to greater than 25 kHz for all deviation settings.

Acknowledgments

Norm O'Neal contributed significantly to the mechanical design of the 8655A, and Mike Ammirato did the mechanical design of the 8654B. Bob Hay furnished solutions to many difficult design problems in both instruments. Thanks also to Larry Seibert, for his assistance during the design evaluation phase, and to Matt Simpson, Bob Waldron, and Greg Nakamoto, for their efforts in preparing the 8655A and 8654B for production. 

Reference

1. R.R. Hay, "Versatile VHF Signal Generator Stresses Low Cost and Portability," *Hewlett-Packard Journal*, March 1974.

2. R.M. Shannon, K.L. Astrof, M.S. Marzalek, and L.C. Sanders, "A Solid State VHF Signal Generator for Today's Exacting Requirements," Hewlett-Packard Journal, February 1973.



Robert R. Collison

Bob Collison developed the FM modulator for the 8654B Signal Generator. A native of the state of Washington, he was born in Yakima and grew up in Spokane. He received his BSEE degree from Washington State University in 1971 and his MSEE from the University of Washington in 1973. He's been with HP since 1973. Bob is single and lives in Mountain View, California. He enjoys skiing, water skiing, hiking, traveling, and tinkering with stereo and quadrasonic audio systems.



Ronald E. Kmetovicz

Ron Kmetovicz, project manager for the 8655A Synchronizer/Counter, was born in Wilkes Barre, Pennsylvania and attended Pennsylvania State University, graduating with a BSEE degree in 1969. He joined HP in 1972 after three years as a designer of airborne communications equipment. He's designed a pair of HP signal generators, one of them the 8640B Option 004, a design that he considers particularly successful. Ron and his wife and two daughters live in San Jose, California. Skiing, handball, and woodworking are his principal recreational activities. He's also studying for his MSEE degree and expects to receive it this year.

SPECIFICATIONS

HP Model 8655A Synchronizer/Counter Counter Characteristics

RANGE: 1 kHz to 520 MHz
SENSITIVITY: <100 mV rms (-7 dBm), ac coupled into 50 ohms. (Typically <-20 dBm, 10 kHz to 200 MHz.)
MAXIMUM INPUT:
 AC: 707 mV (+10 dBm) for accurate count.
 DC: ±25V on EXTERNAL COUNT INPUT, 0V dc (ac only) on rear panel SYNCHRONIZE COUNT INPUT. Both inputs are protected with common fuse.
 COUNT RESOLUTION: 6-digit LED display

MODE	NORMAL	×10 EXPAND ¹
1 kHz to 10 MHz (EXTERNAL)	10 Hz	1 Hz
10 to 520 MHz (EXTERNAL & SYNCHRONIZE COUNT)	1 kHz	100 Hz

ACCURACY: ±1 count ±time base accuracy.

Time Base Characteristics

FREQUENCY: 1-MHz temperature-compensated crystal oscillator
AGING: (constant operating temperature): <0.1 ppm/hr, <2 ppm/90 days
TEMPERATURE: ±5 ppm from 0° to 50°C. (Referenced to 25°C)
TYPICAL OVERALL ACCURACY (after 2 hour warm-up and within 3 months of calibration): Better than ±2 ppm from 15° to 35°C. (Option 001 higher stability time base available.)
REAR OUTPUT: 1 MHz, nominally >0.5 V peak-to-peak 500 ohms.
EXTERNAL REFERENCE INPUT: 1 MHz, nominally >0.5 V peak-to-peak into 1000 ohms. (Not available with Option 001 high stability time base.)

Option 001—High Stability Time Base Characteristics
(after 2 hour warm-up)

FREQUENCY: 1 MHz oven-controlled crystal oscillator
AGING: <0.003 ppm/day
TEMPERATURE: ±0.03 ppm from 0° to 55°C.
RETRACE: Following a 72-hour off period the oscillator frequency shall be within 0.03 ppm of the frequency at turn-off after 1 hour of operation. (Operating the instrument in the stand-by position eliminates the retrace error.)
TYPICAL OVERALL ACCURACY (within 3 months of calibration): ±0.3 ppm, from 0° to 55°C.

8654A/B—8655A Synchronization Characteristics

FREQUENCY RANGE: 10 to 520 MHz
FREQUENCY COUNT RESOLUTION: 1 kHz, or 100 Hz in ×10 EXPAND
FREQUENCY LOCK RESOLUTION: 1 kHz, depressing LOCK +500 Hz button allows a locked resolution of 500 Hz
FREQUENCY ACCURACY: same as time base accuracy
LOCK TIME DURATION (after 5-minute warm-up, constant ambient): 45 min. typical
FM RATE WHILE SYNCHRONIZED: 50 Hz to >25 kHz

FM ACCURACY (with 8654B only):

Total FM Accuracy = 8654B FM Accuracy ± Frequency Correction Error
 Frequency correction error² is typically <±4%.

General

RF LEAKAGE (when operated with 8654B using furnished interface cables):
 Less than 1.5 μV in a 2-turn, 1-inch diameter loop 1 inch away from any surface and measured into a 50-ohm receiver.
POWER: 100, 120, 220, or 240 volts +5%, -10%, 48 to 400 Hz, 100 VA maximum, 2.29 m (7½ ft) power cable
WEIGHT: net, 6 kg (13 lbs 3 oz). Shipping, 6.5 kg (14 lbs 4 oz)
DIMENSIONS: 266 mm W × 101.6 mm H × 317.5 mm D (10½ in × 4 in × 12½ in)

HP Model 8654AB Signal Generator

FREQUENCY RANGE: 10 to 520 MHz in 6 bands
SUBHARMONICS AND NON-HARMONIC SPURIOUS (excluding line related): >100 dB down.
OUTPUT RANGE: +10 dBm to -130 dBm into 50 ohms
AM DEPTH: 0 to 90%
FM DEVIATION—8654A: >0.1% of carrier frequency
8654B: See below.

8654B Frequency Modulation Characteristics

SENSITIVITY ACCURACY (15° to 35°C)³: ±10%. For 100 kHz deviation range above 130 MHz, ±13%.
INDICATED FM ACCURACY (15° to 35°C)³: ±(10% of reading +3% of full scale). For 100 kHz deviation range above 130 MHz, add 3% of reading.
INCIDENTAL AM²: <1% AM at 30 kHz deviation
PEAK DEVIATION: 0 to 30 kHz from 10 to 520 MHz
 0 to 100 kHz from 80 to 520 MHz
DEVIATION RANGES: 0 to 3 kHz, 0 to 10 kHz, 0 to 30 kHz, 0 to 100 kHz
MODULATION RATE: Internal, 400 and 1000 Hz ±10%. External 3 dB bandwidth, dc coupled to >25 kHz
FM DISTORTION³: <2% for deviations up to 30 kHz, <3% for deviations up to 100 kHz.
EXTERNAL FM SENSITIVITY³: 1 volt peak yields maximum deviation indicated on peak deviation meter with FM LEVEL vernier at fully cw position.
PRICES IN U.S.A.:
 8654A AM SIGNAL GENERATOR: \$1900
 8654B AM/FM SIGNAL GENERATOR: \$2275
 8655A SYNCHRONIZER/COUNTER: \$2075
 OPTION 001: HIGH STABILITY TIME BASE, add \$450
MANUFACTURING DIVISION: STANFORD PARK DIVISION
 1501 Page Mill Road
 Palo Alto, California 94304 U.S.A.

¹ Will continue to accurately count from 1 to 10 MHz and from 100 to 520 MHz with loss of most-significant digit (indicated by overflow light). Phase lock is not allowed.
² Frequency correction error is a function of the unlocked 8654B frequency drift. For optimum FM accuracy, this error may be eliminated by unlocking, returning to the desired frequency, and relocking.
³ 400 and 1000 Hz modulation rates.

A 50-Mbit/s Pattern Generator and Error Detector for Evaluating Digital Communications System Performance

To simplify measurements in PCM systems, this new all-in-one instrument has fixed clock rates and a choice of interface levels. Besides measuring bit-error rate, it can also estimate coding errors and measure clock-frequency offset.

by Ivan R. Young, Robert Pearson, and Peter M. Scott

AS THE USE OF time-division multiplexing to combine many pulse-code modulated channels into a single, broadband transmission channel grows, the bit-error rate detector assumes a larger role in the test and maintenance of communications systems.

Bit-error rate is the fundamental criterion for acceptance of any digital communications system. During a system test, a digital pattern is transmitted through the system and compared bit by bit with a locally-generated version of the same pattern. Differences in the patterns are detected, counted, and displayed as bit-error rate, the ratio of bits in error to the total number of bits transmitted. The bit-error rate must not exceed a particular level if distortion in the demodulated signals is to be at acceptable levels.

With the worldwide growth in definitions for pulse-code modulated (PCM) transmission hierarchies, interface levels and codes, it has become feasible to design a new bit-error-rate measuring set to have fixed clock rates and interface levels. This instrument consequently is easier to operate than previous instruments and it is more versatile at the same time.

The new bit-error rate measuring set, Model 3780A (Fig. 1), is a pattern generator and an independent error detector combined in a single portable package that includes crystal-controlled clock oscillators, binary and ternary coded interfaces, clock recovery circuits, automatic receiver synchronization, and pattern recognition circuits. Ideally suited for testing digital multiplex, line, and radio systems, both satellite and terrestrial, one instrument can be used as both sender and receiver in loop-back measurements or two are used in end-to-end measurements, with one serving as the signal source and the other as the signal detector. The new instrument is also a useful laboratory tool in the development of new digital systems, such as those using optical fibers.

At the Sending End

The new measuring set's upper frequency limit of 50 megabits/second covers the first three levels of proposed PCM hierarchies (Fig. 2). The instrument's generator provides digital patterns at any one of three crystal-controlled clock frequencies chosen from a number of options that allow a particular instrument to match the first three levels of one of these hierarchies. Clock recovery at these frequencies is provided in the receiver.

The digital patterns supplied by the new instrument include three pseudorandom sequences (511, 32767, and 1,048,575 bits), five 4-bit words (1111, 0000, 1000, 1010, and 1100), and random words 9, 15, and 20 bits long. An optional version (Fig. 3) generates 16-bit words in addition to the pseudorandom sequences. The longer words and sequences have the characteristics of typical signals, while the shorter ones, though less like typical signals, give easily identifiable patterns that are short enough for viewing on an oscilloscope and that can be readily traced through equipment.

Up to 999 zeros can be added once per sequence to any pattern or word for testing the resonant frequency and Q of clock-recovery circuits. The instrument supplies a trigger output coincident with the start of a sequence or word for synchronizing external equipment.

A choice of output formats is provided. Ternary coded signals, used on PCM line systems, are supplied by the instrument in either the alternate mark inversion (AMI) or CODE formats with an optional choice of two codes, either HDB3/HDB2, or B6ZS/B3ZS (Fig. 4).

The binary output format can be either return-to-zero (RZ) or non-return-to-zero (NRZ). A second data output supplies the binary output advanced six bits with respect to the main output to give some degree of

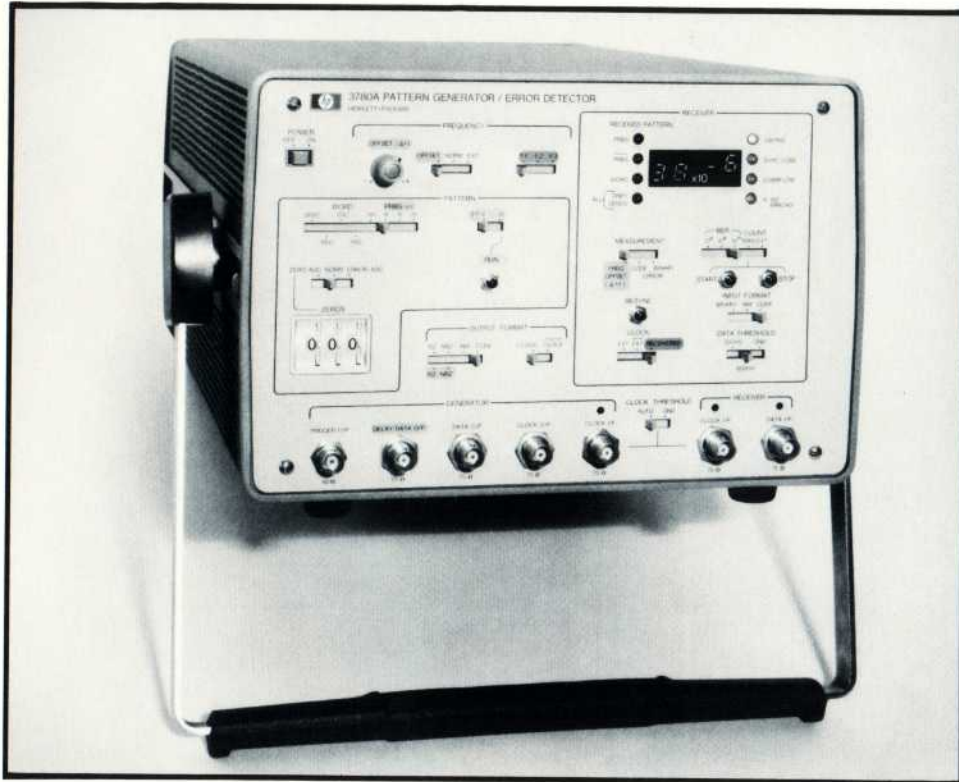

Fig. 1. Model 3780A Pattern Generator/Error Detector combines digital signal source and receiver in one portable package. A wide choice of output formats and automatic receiver synchronization facilitate its use on PCM communications systems.

decorrelation. This facilitates the testing of four-phase phase-shift-keying modulators used in digital radio systems and the checking of two digital channels for crosstalk.

The binary levels are 0V and +3V while the ternary

levels are 0V and $\pm 2.37V$ into 75Ω unbalanced. An optional converter (Model 15508A), useful at clock rates up to 10 MHz, changes the output impedance to a balanced nominal 110Ω that allows direct connection to proposed CCITT interface points.

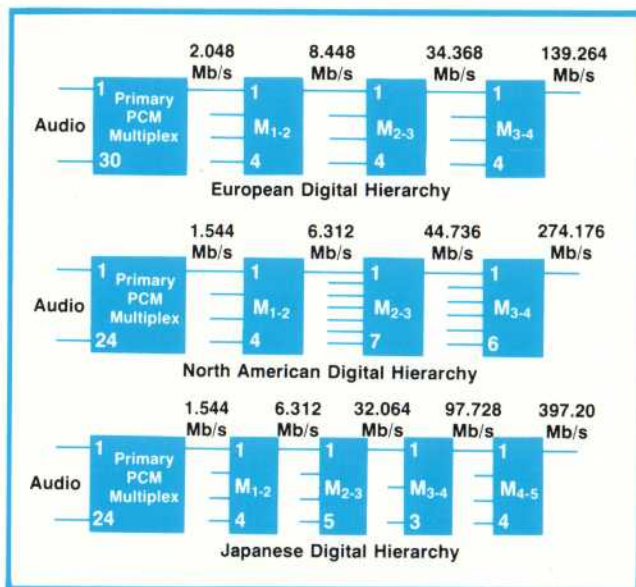

Fig. 2. Proposed hierarchies for digitally multiplexed systems interleave several pulse trains at each multiplex level to obtain a single pulse train at a much higher pulse repetition rate. Model 3780A Pattern Generator/Error Detector can operate at the pulse rates produced by the first three levels of any of these systems.

Automatic Measurement

The receiver part of the instrument can automatically synchronize to any pattern within its repertoire, indicate the type of pattern, e.g. pseudorandom-bit sequence, word, or all 1's or 0's, and start a measurement. With rear-panel printer and strip-chart recorder outputs, this automatic operation allows long periods of unattended monitoring, during which the instrument recovers from temporary faults while leaving a permanent record of the faults (see Fig. 9).

Errors are detected and counted over preset time intervals of 10^6 , 10^8 , or 10^{10} clock pulses and bit-error rate is automatically computed and displayed. A front-panel indicator lights to show when less than 100 errors have been counted to warn the operator that the count may not be statistically significant. The instrument can also display the total errors accumulated over a time interval determined by front-panel start/stop pushbuttons or by the print-command-inhibit signal of an external printer.

Besides measuring bit-error rate, which requires the system under test to be taken out of service while the measurement is made, the new instrument can detect illegal sequences of ternary bauds caused by

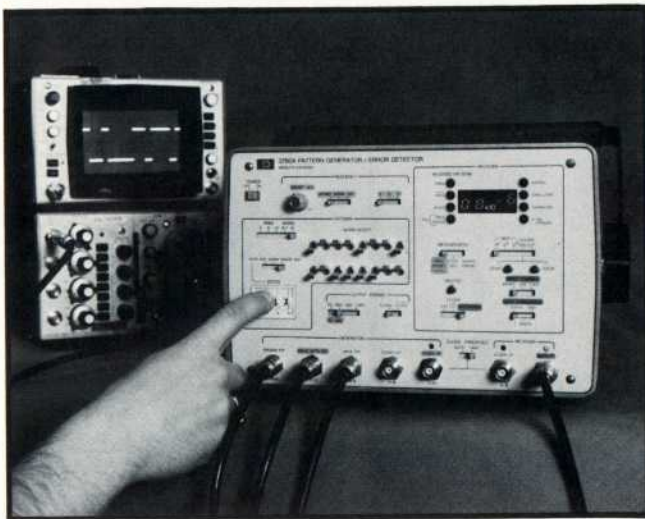

Fig. 3. Option 001 for Model 3780A Pattern Generator/ Error Detector provides a switch register for 16-bit word generation, in addition to pseudorandom bit sequences, allowing greater pattern flexibility.

line errors and count them to provide an estimate of error rate. Since this is possible on any transmitted signal, no interruption of service need occur.

Frequency Offset

The new measuring set also has three other clock oscillators that operate nominally at the same frequencies as the fixed-frequency oscillators but that can be varied over frequency ranges of at least ± 50 ppm. This allows tests of the frequency tolerance of PCM systems. The receiver can measure and display the frequency variations as fractional deviations from the nominal center frequency. It can also measure the deviations of externally supplied clock frequencies as long as they are within 25 kHz of nominal.

The instrument's pattern generator operates with any externally-supplied clock frequency between 1 kbit/s and 50 Mbit/s. In this case, the same frequency must be supplied to the receiver because the tuned circuits in its internal clock recovery circuit respond only to frequencies near the fixed frequencies that the instrument was equipped to supply.

Technical Details

Two advantages are obtained by having two oscillators for each clock frequency: oscillator stability in the normal mode is not compromised, and the fixed oscillator provides a reference for measuring how far the variable oscillator is offset from its nominal rate.

The frequency of the offset oscillator is varied by a varactor diode in series with the crystal unit. At frequencies below 20 MHz where the crystals can operate in their fundamental mode, this arrangement

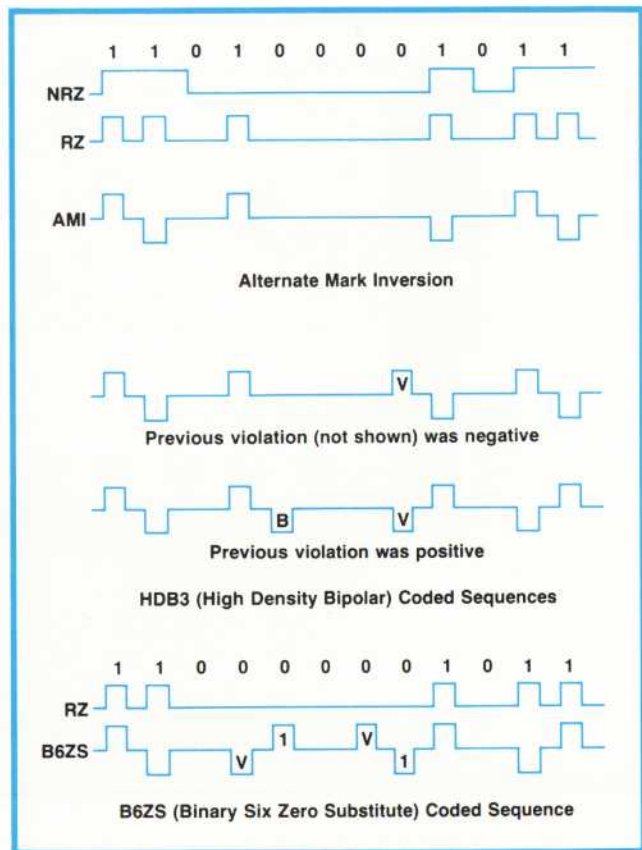

Fig. 4. Output formats of Model 3780A conform to standard practice. The AMI (alternate mark inversion) coding is a three-level code that alternates the polarity of RZ pulses to eliminate any dc component in the average voltage level. HDB3 (high density bipolar) code eliminates long strings of 0's for the benefit of clock recovery circuits by substituting 000V or B00V for four consecutive 0's, where V is an intentional code violation and B is a mark that is inserted to force these violations to alternate in sign. B6ZS (binary six zero substitute) code is similar but substitutes 0V10V1 for runs of six 0's.

works over a suitable range. Above 20 MHz, however, third-overtone crystals normally would be used (and are used in the fixed oscillators) but the third-overtone mode has about one-ninth the pull range of the fundamental mode. Therefore, for clock frequencies in the 20-to-50-MHz range, the offset oscillators are designed to operate at one-third the desired frequency, where they can work in the fundamental mode, and the output is processed through a tripler to get the desired clock frequency.

Frequency offset is measured by mixing the output of the fixed oscillator with the output of the offset oscillator and counting cycles of the difference frequency during 10^6 cycles of the fixed oscillator. This gives the fractional frequency deviation directly in parts per million. The offset of a recovered clock or an externally-supplied clock can be measured by substituting either of these signals for the offset oscillator at the mixer input.

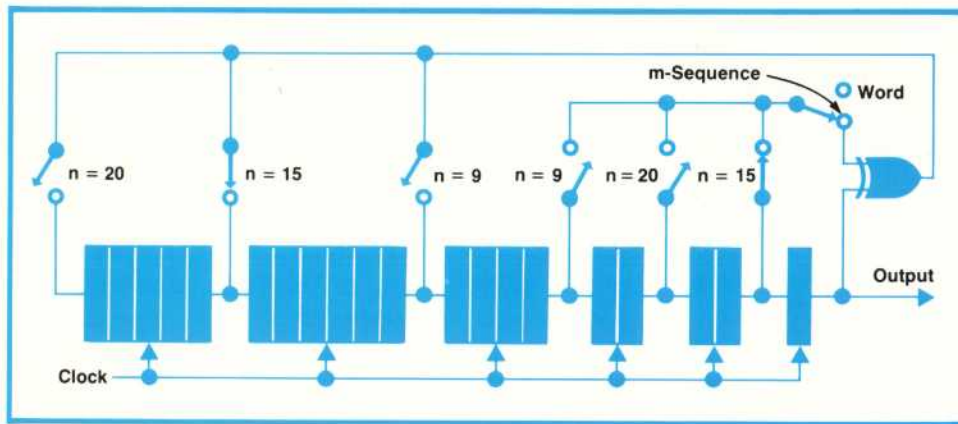

Fig. 5. Pseudorandom binary sequences are generated by a shift register with a gating arrangement that alters the bit stream as it is fed back to the input.

Test Patterns

Maximal-length pseudorandom binary sequences (m-sequences) are universally used as test signals for PCM systems because these patterns have the statistics of normal PCM line signals while being simple to generate and synchronize. The Model 3780A generates m-sequences with a feedback shift register, shown in Fig. 5, whose characteristic equations are specified by both CCITT and the Bell system.

Random words of 9, 15, and 20 bits are generated by opening the inner feedback line so the shift register becomes a simple recirculating word generator. The four-bit words are generated by gating the outputs of a divide-by-four circuit. These words include the maximum density pattern, 1111, and a low-density pattern, 1000, that can be varied in length by adding 0's when testing clock recovery performance against pattern density.

The words 1010 and 1100 find use in testing some 4ϕ PSK systems where alternate bits of the modulator input are applied to the two channels of the modulator. Here, 1010 fully loads one channel while leaving

the other idle and 1100 places data on both channels at half the bit rate.

The optional version of the instrument replaces the four-bit-word logic with a front-panel 16-bit switch register. The 16-bit word can be split into two 8-bit words with one or the other supplied to the output according to the state of a rear-panel input. By setting different pattern densities into the two words, and alternating them under control of a square-wave input, a system's response to changes in pattern density can be observed.

A clock output is also provided. A switch gives a choice of true or complement format for the clock.

Two output stages are used, as shown in Fig. 6, with one producing positive output pulses and the other negative. For ternary outputs, the two pulse trains are combined into a single three-level output. For binary outputs, they feed the same waveform to separate connectors with the coder functioning as a shift register to provide a six-bit delay for the main output.

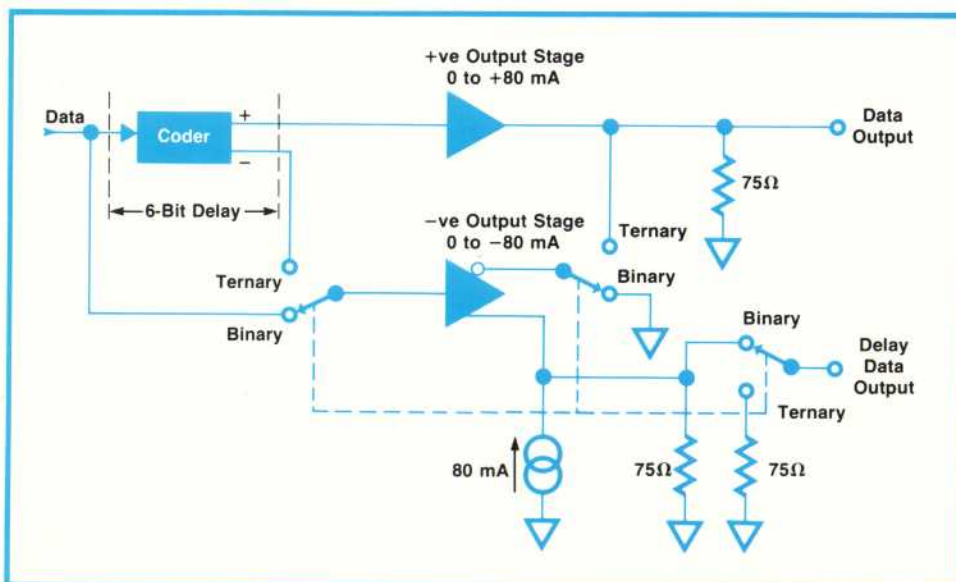

Fig. 6. The output stage combines outputs to derive the ternary waveforms. Because the negative output stage operates between -3 and $0V$, a current source is used to shift the output levels to 0 and $+3V$ when supplying the DELAY DATA output.

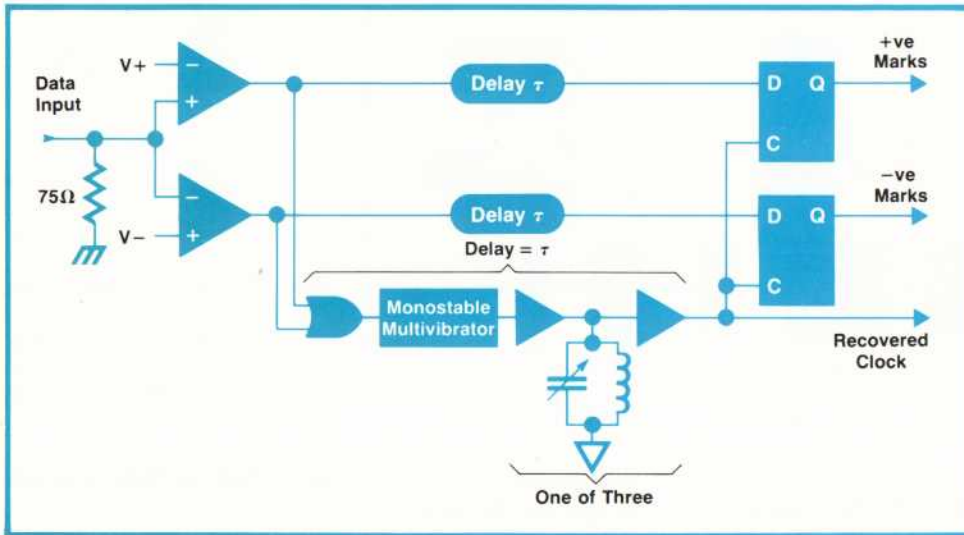

Fig. 7. The receiver input circuits recover the clock and reshape the data. The two short, fixed delay lines compensate for circuit delays in the clock recovery circuit.

Receiving Circuits

On the receiver side, a choice of threshold levels is provided for the data inputs to accommodate signal attenuation in the test cabling. For binary signals, a choice of ground, +200 and +600 mV is provided for the detection level. For ternary inputs, the choice is ± 200 and ± 600 mV ($V+$ and $V-$ in Fig. 7).

As shown in Fig. 7, the ternary negative pulses are inverted and OR'd with the positive pulses to obtain a binary pulse train for the clock recovery circuit. The pulses are reshaped in a monostable multivibrator and then used to drive a tuned circuit that resonates at the clock rate. The sine wave produced by the resonant circuit is squared in a limiter, then used to re-time the input data.

The design of the decoder is in accordance with standard industry practice. It converts the two detected streams back to binary while simultaneously detecting input sequences that violate the coding rules.

Decoders have the property of error extension. A single error in the coded signal can cause multiple errors in the decoded binary signal. For example, if +1 -1 0 0 +1 -1 were transmitted and then received as +1 -1 0 0 0 -1, it would be decoded as 1 1 0 0 0 0 by an HDB3 decoder, giving two binary errors for a single line error. For this reason, measurements of line errors are only estimates of the true error rate but cause no problem as long as the average error extension is known.

Automatic Sequence Synchronization

Sequence synchronization is done very simply by opening the outer feedback line of the receiver's sequence generator and feeding in the incoming bit stream (Fig. 8). Provided that the shift register configuration is identical to the sender's pattern generator, the bit pattern on the feedback line will be identical to the

input bit stream after n bits have been fed in. The feedback line may then be closed. An exclusive-OR gate responds to differences in the subsequent bit sequences and these differences are counted as errors.

Loss of synchronization is detected by overflow of an auxiliary error counter that overflows on the 20,000th error. Overflow automatically switches the shift register to open loop for resynchronization. The SYNC LOSS indicator is also turned on.

The auxiliary error counter is reset every 500,000 clock periods giving a 4% error-rate threshold for resynchronization. Since typical PCM multiplexers resync within 25,000 or fewer clock periods, this averaging interval is long enough to allow a PCM system to lose and regain sync without causing the 3780A to do likewise.

The receiver determines the type of transmitted pattern by trial and error. Each time resynchronization is attempted, the shift register is reconfigured for a different pattern, the process continuing until the correct pattern is found. To speed up the process, re-

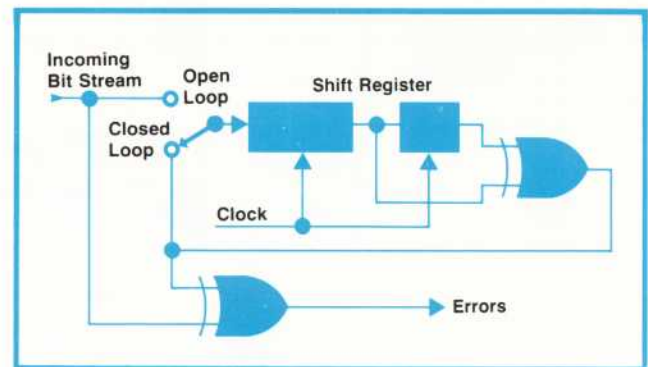

Fig. 8. Resynchronizing consists of feeding the incoming bit stream to the receiver's pattern generator while it is operating open loop. After n bits, where n is the number of shift register stages, the loop is switched from open to closed.

synchronization is considered successful if fewer than four errors are detected during the first 100 clock periods after the shift register feedback loop is closed. If the register configuration is not correct, errors occur at a high rate and resynchronization is initiated quickly. Typically, the correct configuration is found in less than 500 bits.

Resynchronization to each m-sequence is attempted twice, once with the data stream inverted. This enables the receiver to automatically synchronize on binary m-sequences that have been inverted during transmission.

The pattern selection logic drives front-panel indicators to show the type of pattern received (PRBS, $\overline{\text{PRBS}}$, WORD). Another detector continuously monitors the shift register output and when it detects a lack of transitions, it turns on the ALL ONES/ZEROS indicator. This might indicate an incomplete circuit and it also corresponds to alarm conditions on some digital systems.

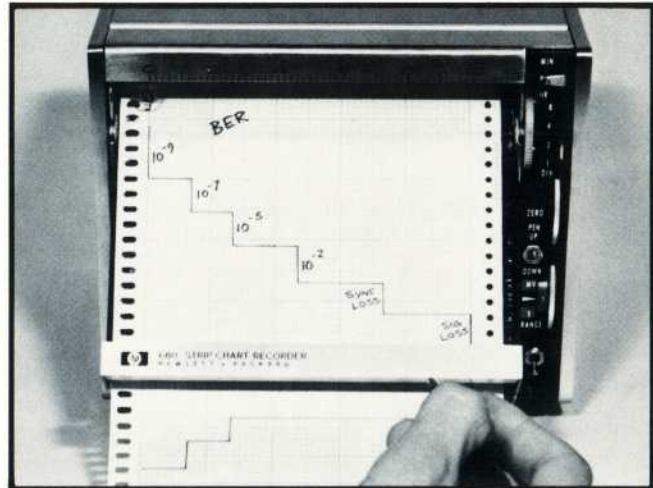

Fig. 9. Pen deflection of the optional strip-chart recorder is proportional to N , the exponent of the bit-error rate where bit-error rate is expressed in the form $A.B \times 10^{-N}$. It also responds to sync loss and signal loss.

ABRIDGED SPECIFICATIONS

HP Model 3780A Pattern Generator/Error Detector

MEASUREMENTS

BINARY ERRORS. Closed loop bit-by-bit detection on any pattern produced by generator, excluding added zeros or alternating words (Option 001).
CODE ERRORS. Violations of coding rule detected on any pattern with AMI, HDB3, or HDB2 coding.
FREQUENCY OFFSET. Measurement of fractional offset from installed crystal rates of generator clock output.

CLOCK

INTERNAL CLOCK. Three crystal controlled frequencies: 2048, 8448 and 1536 kHz; accuracy: ± 3 ppm at ambient; other rates available in range of 1.5 to 50 MHz.
EXTERNAL CLOCK INPUTS. 1 kHz to 50 MHz; 500 mV to 5 V pk-pk; choice of triggering threshold, with indicators; separate inputs for generator and receiver; $\text{CLOCK}/\overline{\text{CLOCK}}$ selection in receiver.

PATTERNS

PRBS. Maximal length 2^9-1 , $2^{15}-1$, or $20^{20}-1$ bit sequences; randomly selectable 9, 15, and 20-bit words.
WORD. 0000, 1000, 1010, 1100, and 1111 fixed words.
ZERO ADD. Up to 999 zeros can be added once per sequence to any pattern.
ERROR ADD. Fixed binary error rate of 10^{-2} can be added to any pattern.

GENERATOR OUTPUTS

DATA OUTPUT. Binary RZ or NRZ 3V pk-pk; ternary RZ with AMI, HDB3, or HDB2 coding, 4.7V pk-pk.
DELAY DATA OUTPUT. 6 bits advanced relative to Data Output; binary RZ or NRZ only, 3V pk-pk.
CLOCK OUTPUT. 3V pk-pk; choice of CLOCK or $\overline{\text{CLOCK}}$.
TRIGGER OUTPUT. 1V pk-pk, 50 Ω impedance; square wave with one transition per sequence.

DATA INPUT

DATA INPUT. 1 kb/s to 50 Mb/s; 500 mV to 5V pk-pk; choice of triggering threshold, with indicator, allowing up to 15-dB attenuation between generator and receiver; binary RZ or NRZ, or ternary RZ with AMI, HDB3, or HDB2 coding.
CLOCK RECOVERY. Clock extraction at installed generator frequencies from input data of any pattern, provided there are 2 or more transitions every 20 bits.
PATTERN RECOGNITION. Auto recognition of all patterns produced by generator, excluding added zeros or alternating words (Option 001); also PRBS; lamp indication of received pattern.
SYNCHRONISATION. Auto sync of local pattern to received pattern, with manual resync override; out of sync ≥ 20000 errors in 500000 bits; resync time typically < 500 bits.

DISPLAY

TYPE. Auto scaled; 7-segment LED
BER. Measured over selectable timebase of 10^6 , 10^8 , or 10^{10} clock periods;

result displayed as $A.B \times 10^{-N}$; indication given if result based on < 100 errors.

COUNT. Measured over manually or printer controlled timebase; result displayed as $A.B \times 10^{-N}$ with overflow indication.

FREQ. OFFSET. $\Delta f/f$; measured over 10^6 periods of nominal crystal clock; result displayed as $A.B \times 10^{-N}$.

FLAGS. GATING lamp indicates measurements in progress. SYNC LOSS lamp indicates local pattern reference has lost sync with incoming data. OVERFLOW lamp indicates internal error or frequency count $\geq 10^9$. < 100 ERRORS lamp indicates less than 100 errors counted during last error measurement.

RECEIVER OUTPUTS (rear panel)

ERROR OUTPUT. One pulse per error; 1V pk-pk; 50 Ω impedance.
CLOCK OUTPUT. Detector clock; 1V pk-pk; 50 Ω impedance.
TRIGGER OUTPUT. One pulse per sequence; 1V pk-pk; 50 Ω impedance.
PRINTER OUTPUT. 8421 BCD; 10 columns; suitable for driving HP 5050, 5055 or 5150 Printers, operates on BER and COUNT only; 50-pin Amphenol connector.
RECORDER OUTPUT. 0 to 1 mA with 16 levels of current; calibration of FSD and zero by switches.
BER. Eleven level output representing error rates of $< 10^{-8}$, $< 10^{-7}$, ..., $< 10^{-1}$, and $\geq 10^{-1}$, sync loss, and no signal.
COUNT. Four level output representing signal with no errors, signal with errors, sync loss, and no signal; binding post connectors.

GENERAL

CONNECTORS. 75 Ω BNC, unless otherwise stated.
POWER REQUIREMENTS. 115V ac ± 10 -22%, or 230V ac ± 10 -18%; 48 to 66 Hz; approx. 110VA max.
DIMENSIONS. 195mm high, 335mm wide, 475mm deep (7 $\frac{3}{4}$ \times 13 $\frac{3}{16}$ \times 18 $\frac{5}{16}$ in).
WEIGHT. Net: 12.5 kg (27.5 lb).
PACKAGING. Modified 1700 oscilloscope case; clip-on front cover with provision for power cable, accessories, and operating manual.
PROBE POWER (rear panel). External fused supplies of +5V, 200 mA, and -5V, 200 mA, for HP logic probes.

OPTIONS

001. All words replaced by 16-bit front-panel programmable word, or two 8-bit words alternated by external signal at a rate up to 100 kHz.
 002. Siemens 1.6mm connectors.
 100. Internal clock frequencies: 2048, 8448, and 34368 kHz.
 101. Internal clock frequencies: 1544, 6312, and 44736 kHz; B6ZS/B3ZS codec.
 102. Internal clock frequencies: 1544, 6312, and 3152 kHz; B6ZS/B3ZS codec.

PRICES IN U.S.A.:

\$6815. Option 002, add \$65
 Option 001, add \$250. Options 100, 101, and 102, no charge

MANUFACTURING DIVISION: HEWLETT-PACKARD LIMITED
 South Queensferry
 West Lothian, Scotland

Acknowledgments

Project definition involved many people, chief among them being Tony Annis, John Stinson, Peter Hockett and Tom Crawford. Robert Duncan designed the switching power supply, Robert Jelski developed the output stages, James Robertson the counter control and printer output and Ken Coles was product designer. A smooth production transfer resulted from the efforts of Brian Woodroffe in R & D and Philip Whitaker in Production Engineering. 



Robert Pearson
 Rob Pearson joined HP Ltd. in 1973 to work on the 3780A after gaining four years experience elsewhere in the British electronics industry. He's a graduate of Glasgow University (BSc, 1969) and is now working part-time toward an MSc degree in digital techniques at Heriot-Watt University. In his spare time, he plays golf, is a member of the R & D soccer team, and does some woodworking. Rob and his wife have one son.



Ivan R. Young
 Joining HP on getting his BSc degree from Heriot-Watt University (Edinburgh, Scotland), Ivan Young worked on the 3760A Data Generator and allied investigations before becoming project manager for the 3780A Pattern Generator/Error Detector. Along the way he earned the MSc degree from Heriot-Watt (1975). In off hours, Ivan enjoys mountaineering in his native Scotland, goes caving, and plays Go, the Oriental board game.



Peter M. Scott
 Since graduating with a BSc degree from Heriot-Watt University in 1971, Peter Scott has been totally involved with the 3780A Pattern Generator/Error Detector. Completing his contribution in early 1975, he is now involved in the design of new high-speed digital link test equipment. Married, and with one daughter, most of his spare time is devoted to restoring his crumbling Georgian house.

Hewlett-Packard Company, 1501 Page Mill Road, Palo Alto, California 94304

HEWLETT-PACKARD JOURNAL
MARCH 1976 Volume 27 • Number 7

Technical Information from the Laboratories of Hewlett-Packard Company

Hewlett-Packard S.A., CH-1217 Meyrin 2
 Geneva, Switzerland
 Yokogawa-Hewlett-Packard Ltd., Shibuya-Ku
 Tokyo 151 Japan

Editorial Director • Howard L. Roberts
 Managing Editor • Richard P. Dolan
 Art Director, Photographer • Arvid A. Danielson
 Illustrator • Sue M. Perez
 Administrative Services, Typography • Anne S. LoPresti
 European Production Manager • Michel Foglia

Bulk Rate
 U.S. Postage
 Paid
 Hewlett-Packard
 Company

208107JUHNAABLACAAA 165
 MR C A BLACKBURN
 JOHN HOPKINS UNIVERSITY
 APPLIED PHYSICS LAB
 JOHNS HOPKINS RD
 LAUREL MD 20810

CHANGE OF ADDRESS • To change your address or delete your name from our mailing list please send us your old address label (it peels off). Send changes to Hewlett-Packard Journal, 1501 Page Mill Road, Palo Alto, California 94304 U.S.A. Allow 60 days.