



The Present Attainments of Adjustable Power Supplies

The power supply designs discussed in the accompanying article are those of -hp-'s Harrison Laboratories division. H-Labs was formed in 1954 to design and build specialized equipment for TV studios, the first product being an aperture equalizer for TV camera chains. In 1955 H-Labs designed a power supply as a part of a TV equipment package, the specifications requiring that the power supply have low impedance at the color sub-carrier frequency. The H-Lab supply designed for this requirement performed so well and so reliably that addi-

tional orders came. As H-Labs' reputation grew, power supplies came to be the major item in H-Labs' product line.

Growing at a very high rate, Harrison Labs turned to outside sources in expanding its facilities, resulting in its association with -hp-.

Harrison Laboratories of Berkeley Heights, New Jersey, with William Harrison as manager, is now a division of Hewlett-Packard. It is expected that -hp-'s future efforts in the d-c solid-state power supply field will be centered at H-Labs.

SOPHISTICATION in laboratory power supply design is bringing more flexibility to these instruments and new conveniences to the user. Remote programming, remote sensing, and the ability to operate with one-knob control either in series or in parallel with other supplies are some of the features presently being designed into power supplies. Power supply performance now includes full overload protection through adjustable cur-

rent limiting, low output impedance over a wide band of frequencies, short recovery time to instantaneous changes in line voltage or load current and no overshoot on turn-on, turn-off or power failures. At the same time, better use of components results in compact units of high efficiency and low heat dissipation.

Considerable engineering effort has been expended on making modern power supplies



Fig. 1. Harrison Laboratories' Model 865B Power Supply is less than 8 inches wide, weighs only 12 pounds but supplies up to 0.5 amp at 0-40 volts. Any number of these compact supplies may be operated in series or parallel for higher voltages or currents. Either constant voltage or constant current mode of operation is possible.

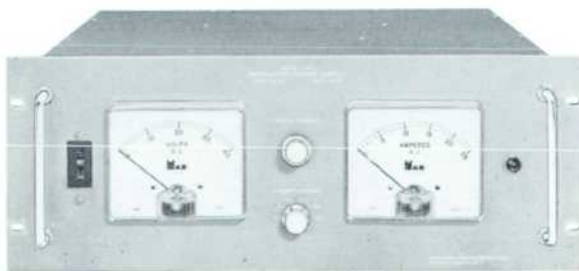

Fig. 2. High-efficiency SCR power supply, H-Lab Model 520A, supplies 0-25 amps at 0-36 volts in 5½ inches high rack mounting cabinet. Low power-loss in circuits does away with need for cooling fan. Fast circuit response eliminates line transients from output.

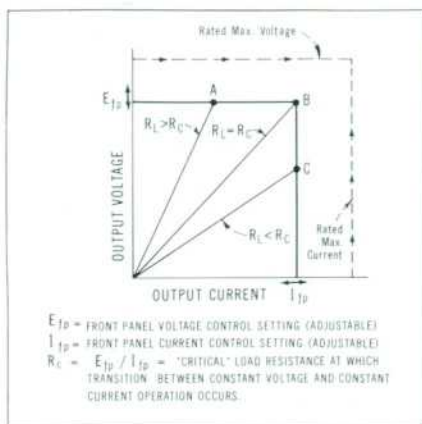

Fig. 3. Voltage/current characteristics of CV/CC power supply. No switching is required for transition from constant voltage to constant current operation or vice versa.

immune to most laboratory mishaps, such as accidental shorts, open-circuits, or sudden line transients caused by spot welders, electric ovens and the like. Some of these design features, as embodied in a broad variety of power supplies manufactured by Harrison Laboratories, -hp-'s power supply division, are described here.

CONSTANT-VOLTAGE/CONSTANT-CURRENT SUPPLIES

A recent innovation in laboratory instruments is represented by the constant voltage/constant current (CV/CC) power supply. These supplies operate in the conventional constant voltage mode when the load draws less than some chosen maximum current. If the load should increase and attempt to draw more than the selected current, the CV/CC supply then behaves as a constant current source, adjusting its output voltage to constrain the current to the chosen level.

Besides safely limiting the maximum current when used as a constant-voltage source, the CV/CC supply also limits the maximum open-circuit voltage when operating as a constant-current source. As a battery charger, for instance, the CV/CC supply charges a battery at a constant selected rate and then

abruptly reduces the current to a trickle charge when the preselected voltage level is reached.

In the constant current mode, CV/CC supplies are well suited for supplying fixed currents to focusing coils or other magnetic circuits, the current remaining constant despite temperature induced changes in coil resistance. Having both constant voltage and constant current modes of operation in one supply in no way degrades performance in either mode.

Under light or no load conditions, the CV/CC supply operates in the constant voltage mode, maintaining the output voltage at the value selected by the front panel (or remote) control, as shown by point A on the graph of Fig. 3. As the load resistance decreases, the current increases with little or no voltage change until the selected maximum current limit is reached. This is the "critical" value of load resistance (point B) and represents the V/I ratio of the front panel control settings. Further decrease in load resistance causes the voltage to drop but the current output now remains constant, as represented by point C on the graph. The critical value B is arbitrarily moved around by the independent voltage and current controls.

HOW THE CV/CC SUPPLY WORKS

A preliminary look at a constant voltage regulator, Fig. 4, will help to introduce the operation of the constant current regulator. As is common practice, the voltage comparison amplifier and regulator comprise a feedback control system which adjusts the output voltage to bring the voltage difference between the inputs of the comparison amplifier to zero. While this is the basic principle of a voltage regulator, it is of interest to note that in terms of feedback theory, the regulated supply may be considered as a d-c power amplifier in which the "input" is the reference voltage, β is the divider ratio, and line voltage and load changes are disturbances in the μ circuit. The feedback acts to suppress these disturbances by the factor $1/(1-\mu\beta)$, where $\mu\beta$ is the loop gain.*

As shown here, one amplifier input is connected to the negative output bus. The other input is connected to summing point P, which is shown at the junction of fixed resistor R_r and Output Voltage Adjust variable resistor R_p . The control action continuously adjusts the voltage on the positive bus to bring the

*Oliver, B. M. "Automatic Volume Control as a Feedback Problem." Proc. IRE, Apr. '48.

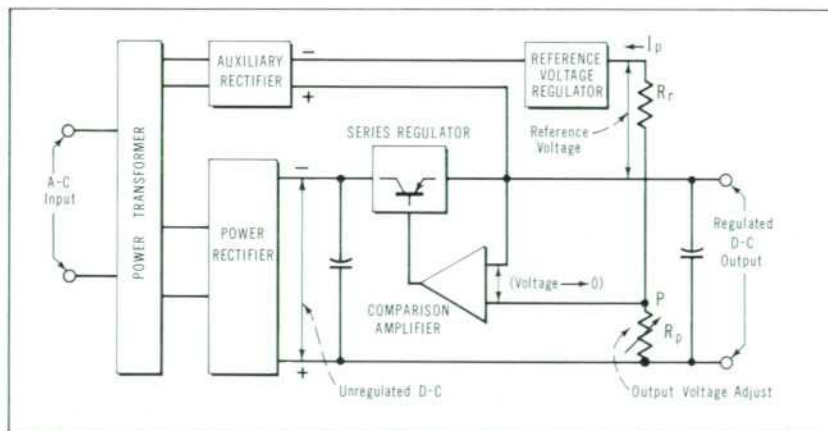

Fig. 4. Constant voltage regulated power supply. Voltage sensing circuit may be connected through separate leads directly to load, achieving optimum regulation at load terminals.

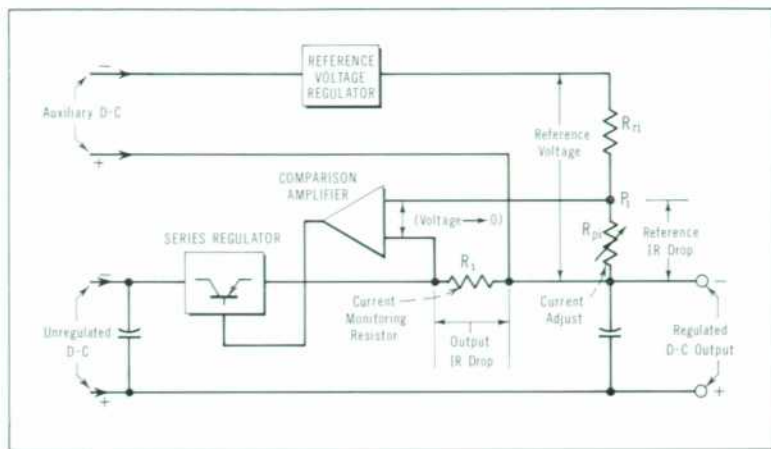

Fig. 5. Constant current regulated supply. Reference voltage source and high gain amplifiers achieve constant current operation, in contrast with current limiting which only prevents current from exceeding selected maximum.

voltage at point P to the negative bus potential.

With point P held at the negative bus voltage, the voltage drop across fixed resistor R_r is the same as the reference voltage, and this voltage drop remains constant during operation. The current I_p through resistor R_r , and thus through R_{pi} , likewise is held constant so that the IR voltage drop across R_{pi} is determined solely by the resistance value of R_{pi} . The power supply output voltage then is a linear function of the resistance of R_{pi} .

As will be discussed later, there are several advantages to deriving a control voltage in this manner. For one, the arrangement makes it possible to program the power supply remotely by disconnecting R_{pi} and substituting an external resistance. The remote programming resistor may be fixed, variable, or switched to discrete values, switching external resistors enabling the power supply to be reset to precise voltages.

Connections to R_{pi} are brought to a terminal strip at the rear of H-Lab supplies for convenient changeover to remote programming. The output voltage then is specified in terms of volts per ohm of programming resistor. In addition, the comparison amplifier input connected

to point P may be disconnected from the internal reference and reconnected to any external voltage, thus converting the power supply into a unipolar d-c power amplifier. The terminal strip connections also permit remote error sensing to be used if heavy currents in the leads connecting the load cause troublesome voltage drops.

A constant current regulator circuit is shown in Fig. 5. The same series regulator and constant voltage reference source of the CV regulator are employed here, but the current programming resistor R_{pi} is returned to the negative bus. Also,

a low value current monitoring resistor R_i (typically 3 ohms in a 0.5 amp supply) is inserted in series with the negative bus. The action of the control circuit now is to bring the comparison amplifier inputs to the same potential by matching the voltage drop across R_i to the voltage drop across R_{pi} . The output current thus becomes a function of the Current Adjust resistor R_{pi} . Here again the Current Adjust resistor R_{pi} may be disconnected and an external resistance used for remote programming, or an external reference voltage may be substituted.

The combination of constant voltage and constant current regulators in one power supply is shown in Fig. 6. The amplifiers described previously are simply connected in parallel to a common series regulator. In practice, the outputs of the comparison amplifiers are taken from the collectors of transistors, each one of which cuts off and is ineffective when the other has control of the output. Either or both of the regulating functions may be programmed remotely and they are adjustable separately.

A popular CC/CV power supply using these techniques is the Harrison Lab model 865B, shown in Fig. 1. This compact unit supplies

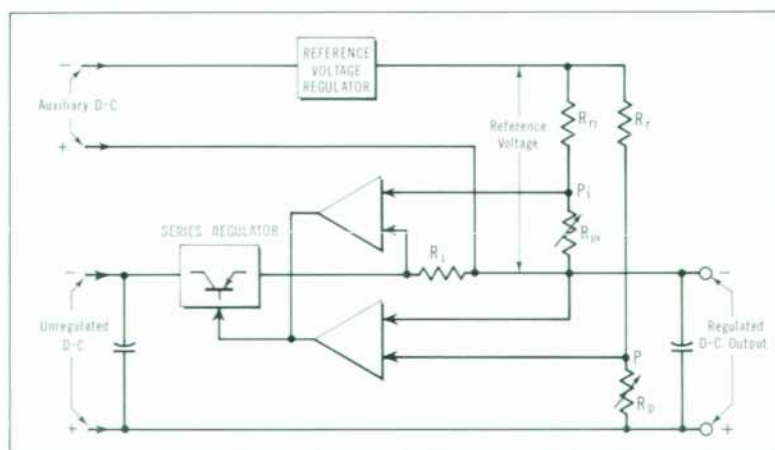

Fig. 6. Constant voltage/constant current (CV/CC) regulated supply. In heavy duty H-Lab CV/CC supplies, disconnect diodes in series with comparison amplifier outputs sharpen transition from constant voltage to constant current operation.

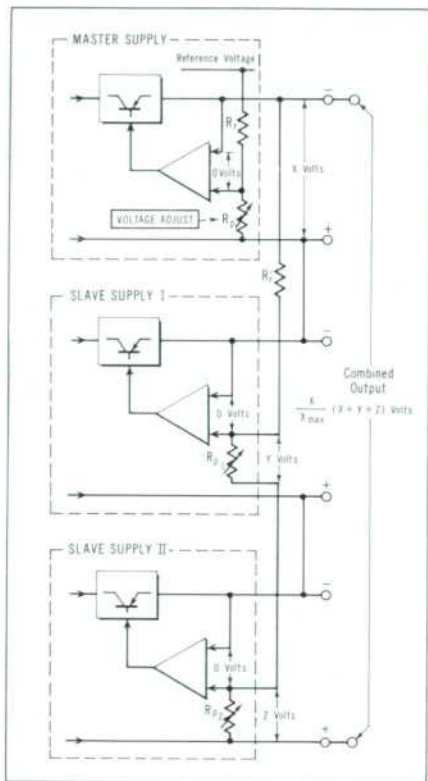

Fig. 7. Series connection (Auto-series) of power supplies for one-knob control. Master supply becomes reference source for slave supplies so that slave voltages track master voltage proportionally.

up to 0.5 amps at any voltage between 0 and 40 volts. High gain in the regulator chain holds the output voltage within 0.01% or 1 mv (whichever is greater) for a 0.5 amp change in load, or holds the output current within 250 μ amps during constant current operation.

AUTO-SERIES AND AUTO-PARALLEL OPERATION

For higher voltages, power supplies simply may be stacked with the positive bus of one tied to the negative bus of the next but control of all supplies by a single Voltage Adjust control is enabled by the addition of one control lead, as shown in Fig. 7. With this connection, the "Master" supply becomes the reference voltage for the others, which have had their internal voltage references disconnected (a new fixed resistor R_1' is added). The slave supplies, set individually to any

voltage, will track the Master voltage proportionally.

The CV/CC supplies may be interconnected for parallel operation, as shown in Fig. 8, without the large circulating currents that usually arise from slight inequalities in the output voltages of any two low impedance sources. Here, the voltage regulators of the slave supplies are disconnected from their own references and reconnected as shown. Each slave regulator adjusts its current output so that the voltage drop across its current monitoring resistor matches that across the current monitoring resistor in the master supply. This action is effective throughout both the constant voltage and constant current operating ranges, with all control coming from the master supply. Any number of H-Lab power supplies of the same model number may be connected for Auto-Parallel operation.

ZERO OUTPUT IMPEDANCE

For tightest voltage regulation, and also to prevent mutual coupling between parallel loads, the effective output impedance of a power supply ideally should be zero. Formerly, the impedance of regulated supplies never quite reached zero, for reasons explained here.

The output impedance Z of a regulated power supply (or any feedback amplifier) can be expressed by the equation¹:

$$Z = Z_o \frac{(1 - \mu\beta_{sc})}{(1 - \mu\beta_{oc})}$$

where Z_o is the impedance looking back into the supply with the amplifier disconnected, $\mu\beta_{sc}$ is the loop gain with the output short circuited, and $\mu\beta_{oc}$ is the loop gain with the output open circuited. In the constant voltage mode, $\mu\beta_{sc} = 0$ and $\mu\beta_{oc}$ is very large. In the constant current mode, $\mu\beta_{sc} = 0$ and $\mu\beta_{oc}$ is very large and negative. It is

¹Bode, H. W. "Network Analysis and Feedback Amplifier Design," Chap. 5, D. Van Nostrand Co. Inc., New York, 1945.

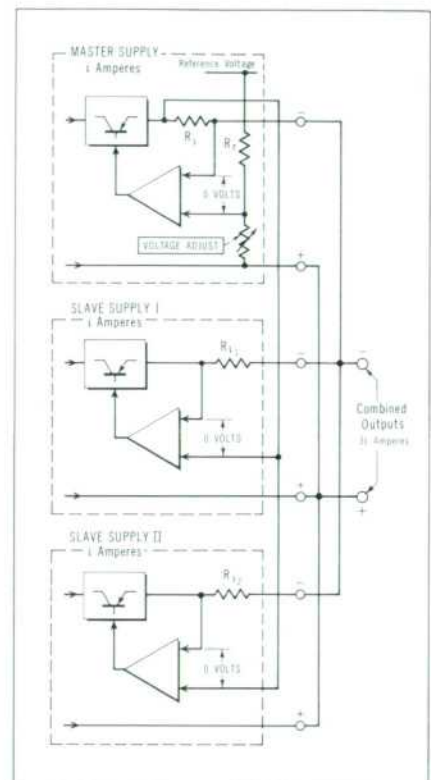

Fig. 8. Parallel connection (Auto-parallel) of power supplies. One-knob control is retained in either constant voltage or constant current operation.

evident that in the CV mode, the output impedance decreases as regulator gain increases, the impedance approaching but never quite reaching zero.

If positive feedback is added to the amplifier of gain μ in the expression above, totally within the negative feedback loop, there results a new value of feedback amplifier gain μ' , expressed by the relation:

$$\mu' = \mu / (1 - \mu\beta')$$

where β' is the locally introduced positive feedback factor. Now, β' may be chosen to make the product $\mu\beta' = 1$, in which case the denominator vanishes and μ' goes to infinity. This value of μ' may be substituted for μ in the original expression for output impedance, in which case Z becomes zero.

Adding a positive feedback loop to the comparison amplifier, simply

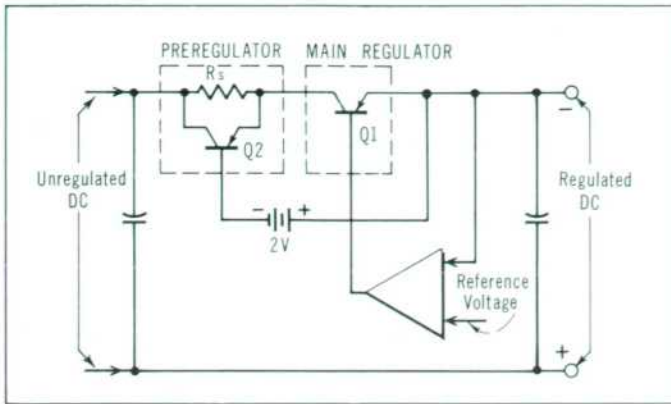

Fig. 9. Power supply with preregulator. For higher power, additional preregulators may be added either in series or parallel.

by adding a resistor between output collector and input base of a two-stage amplifier, can result in zero output impedance. As a matter of fact, by increasing the positive feedback beyond the optimum point, a negative output impedance is obtained which means that the output voltage *rises* slightly if output current increases. With enough positive feedback to make $\mu' = \infty$, the circuit could be on the verge of oscillating were it not stabilized by the overall negative feedback loop.

The 865B, as adjusted at the factory, has less than 0.01 ohms internal impedance from d-c to 100 cps. Above 100 cps, the gain of the positive feedback loop falls off but the internal impedance is no more than 0.02 ohms at 1 kc, rising to 0.1 ohms, typically, at 100 kc. At higher frequencies, the inductance of the output capacitor (0.3 μ h) determines the output impedance. Computer-grade low-inductance electrolytic capacitors are used in all H-Lab supplies.

CONSERVING THE SERIES REGULATOR

The series regulator of a simple regulated power supply with fixed rectifier voltage is often called upon to dissipate considerable amounts of power. This power reaches a maximum when full current is drawn at a low output voltage since the regulator is required to drop the recti-

fier voltage to the desired output level. In such "brute force" designs, excess power handling capacity must be built into the series regulator to meet this condition.

A more efficient regulator design makes advantageous use of a "preregulator," as shown in Fig. 9. Here, resistor R_s in series with the main regulator dissipates most of the power when the supply is used for low output voltages at high currents. In a 40 volt supply, for instance, the resistor reduces Q1's collector-emitter voltage to approximately 1.5 volts, limiting Q1's power dissipation.

When the supply is to be used near its maximum output voltage, the series resistor is removed from the circuit by the action of Q2, which turns on whenever the voltage drop across Q1 is low enough. The preregulator therefore functions as a variable resistance to dissipate power as needed. Q1, however, retains full control of the out-

put at all times, right down to zero volts out.

A smaller power transistor having higher frequency response may be used for Q1, reducing the power supply output impedance over a wider band of frequencies. The preregulator also reduces ripple and improves line voltage regulation because of the emitter-follower type action of Q2.

SCR-CONTROLLED POWER SUPPLIES

Where heavy current outputs are required, some form of control device often is added to the rectifier circuit to further limit power loss in the regulators. The control limits the rectifier output voltage to some level suitably higher than the output terminal voltage.

The rectifier voltage control may be simply an autotransformer mechanically coupled to the output voltage control to make the rectifier voltage track the output voltage. This method, though, is not adapted readily to remote programming and has the further disadvantage of not protecting the regulating elements in the event of a short-circuit on the output terminals.

More recent techniques use thyatrons or silicon controlled-rectifiers (SCR's) as rectifying elements. The firing angles of these devices are controlled to keep the input capacitor charged to a level only a few volts higher than the output voltage. With this method, the rectifier voltage can be made to track the output voltage automatically. So-



Fig. 10. High voltage (320 v) from an all solid-state supply is available in H-Labs' Model 895A, supplying up to 1.5 amps dc. "Piggyback" regulator eliminates need for expensive high-voltage transistors.

phisticated control circuits with SCR's as the only power controlling element are able to maintain 0.5% regulation.

A simplified diagram of a typical H-Lab SCR regulated power supply is shown in Fig. 11. The same reference voltage, summing point and voltage comparator circuitry discussed previously are used but there is no series regulating element. Instead, silicon controlled-rectifiers are placed in two of the rectifier bridge arms.

The rectifiers pump up the relatively large input capacitor to the required voltage. This capacitor feeds the large output capacitor through the small series filter resistor (typically 0.04 ohms in a 25 amp supply). The comparison amplifier then monitors the voltage on the output capacitor and controls the firing angle of the SCR's to maintain this voltage at the desired level.

The output of the comparison amplifier is a constant current which charges ramp capacitor C_R . The ramp, shown in Fig. 12A, starts at the beginning of each half cycle of the input a-c waveform and terminates when C_R is discharged at the end of the half cycle. When the ramp voltage reaches the turn-on level of blocking oscillator transistor Q3, this transistor, previously cut-off, conducts and generates an output pulse. The SCR which is fired by the blocking oscillator continues to conduct, of course, during the remainder of the half cycle. Conduction time is just long enough to bring the charge on the input capacitor up to the desired level.

The steepness of the ramp slope, determined by the current supplied by the voltage comparator, therefore controls the firing angle of the SCR's. A slight drop in the output voltage as a result of increased current demand, for example, increases the ramp current. The SCR's then

fire earlier during the a-c cycle, supplying more energy to the input capacitor.

An important feature of Harrison Lab SCR regulated high current supplies is their immediate response to changes in the input line voltage. This fast response is the result of a-c bias, added to the ramp, which alters the firing angle of the blocking oscillator to make this angle responsive to the amplitude of the a-c input. For instance, if the input voltage were to increase, the resulting increase in a-c bias would delay the firing angle of the blocking oscillator. Conduction time of the SCR's is then reduced, compensating for the increased line voltage. This compensation occurs within one cycle of a change in input line voltage before the output voltage is affected by the change. This half cycle speed has a far faster response than that found in magnetic amplifier power supplies, and produces remarkable immunity to line transients.

The series filter resistor is also used as a monitoring resistor for current limiting in the SCR regulated supply. A typical SCR supply, H-Lab model 520A (Fig. 2), supplies up to 25 amperes at 0 to 36 volts. Combined line and load regulation is within 0.5% for a load change from no load to full load accompanied by an input line change from 125 to 105 volts a-c. Ripple and noise are less than 1%.

SCR SUPPLIES WITH SERIES REGULATION

For extremely tight output voltage regulation and ripple requirements, SCR regulated supplies are combined with series regulators similar to those discussed previously. The SCR control circuit itself does not use a voltage comparator in the usual manner but responds instead to the voltage drop across the series regulators. This maintains a fixed voltage drop across the regulators, nominally two to three volts. The main regulator controls

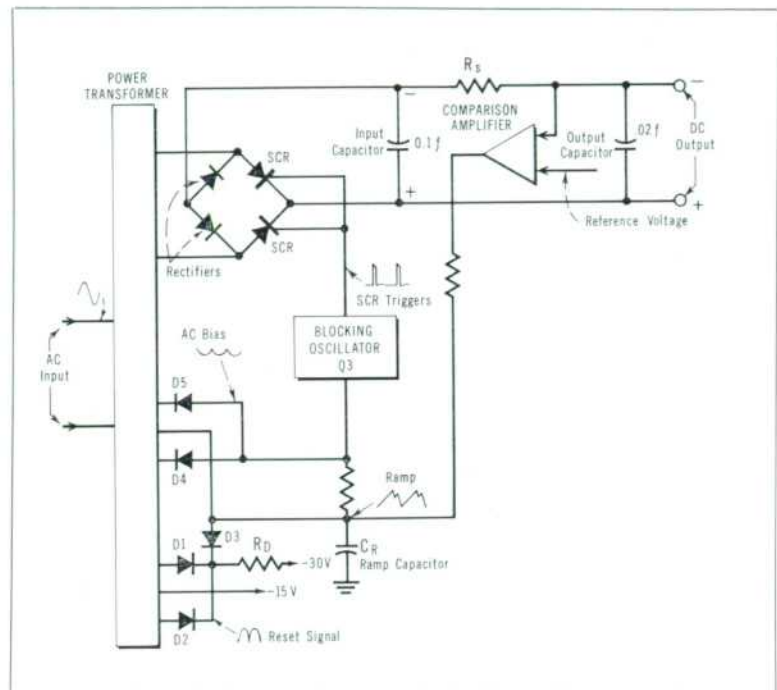

Fig. 11. Regulated supply with SCR control. These supplies may be connected for remote programming, remote sensing, Auto-series, and Auto-parallel operation.

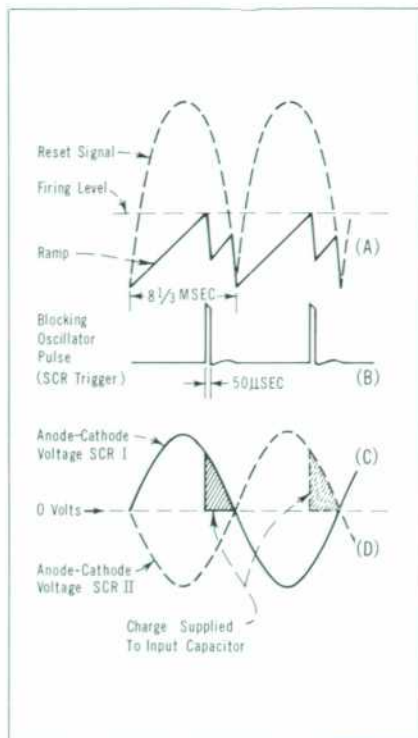

Fig. 12. SCR control waveforms.

the output voltage while the SCR circuit merely maintains the voltage across the series regulating transistor just above its saturating voltage.

The preregulator normally would not be required since the voltage across the regulators is limited, but it is included to protect the regulator during transient conditions. For example, if the output of the power supply were shorted suddenly, most of the original output voltage would appear across the regulators for a brief interval while the input capacitor discharges. During this transition period, the preregulator functions as previously described to limit the voltage drop across the main regulator.

These power supplies react immediately to sudden changes in output current. This is accomplished simply by adding a control link which senses the voltage drop across the current monitoring resistor.

The Harrison Labs model 810B is typical of power supplies combin-

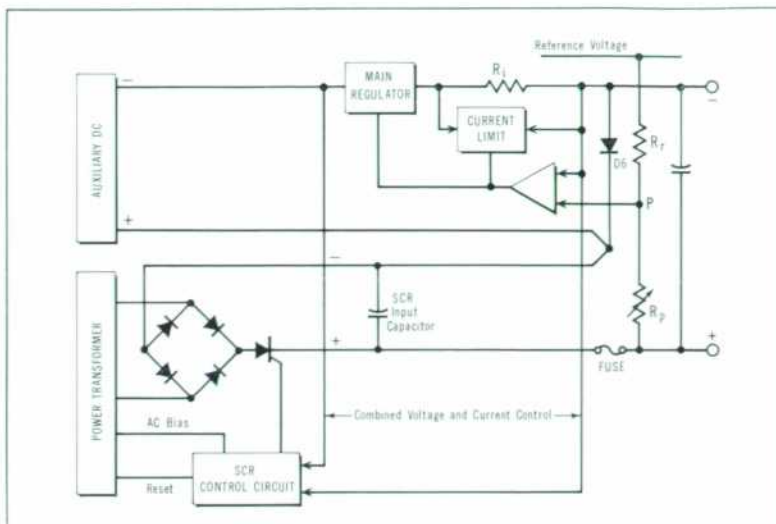

Fig. 13. Solid-state high voltage supply with "piggy-back" regulator. Piggy-back regulator supply itself delivers no more than 20 volts to combined output.

ing series regulation with SCR control, supplying up to 7.5 amps at 0-60 volts and while allowing a voltage change of less than 0.02% or 10 mv, whichever is greater, for a 7.5 amp load change.

SCR HIGH VOLTAGE POWER SUPPLIES

A significant innovation in semiconductor power supplies is made possible by combining SCR control with series regulated control in another manner. Higher voltage outputs (up to 320 v) now are possible without use of expensive high-voltage transistors. The efficiency and reliability of semiconductor circuitry are brought here to a field formerly dominated by vacuum tubes.

The diagram of such a supply is shown in Fig. 13. The series regulator known as a "piggy-back" regulator, rides on top of the main SCR supply. As shown on the diagram of Fig. 13, the piggy-back regulator is a CV/CC control of the type described earlier but it has its own d-c source and functions independently of the main SCR supply. Its positive bus, however, is tied in series with the negative bus of the main SCR supply while the voltage programming resistor is extended

out to the positive bus of the SCR supply.

The SCR control monitors the voltage drop across the series regulators and adjusts the SCR voltage to maintain the desired voltage drop. This means that the SCR control, in an effort to adjust the series regulator voltage drop, brings the summing point within the operating range of the comparison amplifier. In this way, the Voltage Adjust resistor controls the combined output voltage from zero all the way to 320 volts.

Current monitoring is included with this type of supply so that the SCR's respond immediately to changes in output current demand. Also, a-c bias for line control is included. Diode D6 is included for short circuit protection; a short on the output terminals would drop the output voltage before the SCR input capacitor could discharge. D6 conducts, draining away the charge while protecting the series regulators against a reverse voltage.

The H-Lab model 895A (Fig. 10), using a piggy-back regulator, supplies up to 1.5 amps at 0-320 volts. Load and line regulation is within 0.01% or 30 mv at any output voltage from no load to full load.

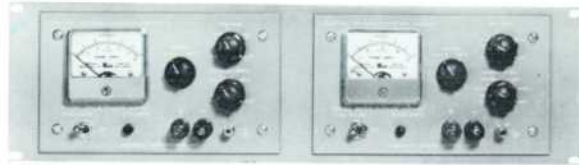

Fig. 14. Two compact H-Lab supplies fit on one rack mounting panel. Model 865B, described in text, is shown with companion 0-18 v, 0-1.5 amp Model 855B. Switched meters read either voltage or current output.

ACKNOWLEDGMENT

The new versions in power supply design described here were developed by the following engineers of *-hp-'s* Harrison Labs Division: Bob Buckner, Brad Bunker, Art Darbie, Bob Graham, Bill Harrison and Don Tighe.

REPRESENTATIVE LIST OF HARRISON POWER SUPPLIES

MODEL	OUTPUT VOLTS	OUTPUT AMPS	LOAD AND/OR LINE REGULATION	RMS RIPPLE & NOISE (MV)	RECOVERY TIME# (μSEC)	SPECIAL FEATURES	PRICE
520A	0- 36	0-25	0.5% combined	360	50 ms	Auto-Series & Auto-Parallel Operation, Variable current limit.	\$575.00
721A	0- 30	0-15	0.3%	0.15	—	Four position current limit switch.	145.00
723A	0- 40	0-0.5	20MV	0.15	—	Variable current limit, Auto-Series & Auto-Parallel Operation—Modular Design.	225.00
726AR	0- 60	0-2	5MV	0.25	200	Variable current limit.	545.00
801C	0- 25	0-0.2	2MV	0.1	50	Strain gage supply—9 fit on 5¼" H panel.	149.00
802B	Dual 0- 36	0-1.5	0.01%	0.2	100	Two sides can be seriesed for 0-72V.	580.00
809A*	0- 36	0-10	0.02%	0.5	100	Variable current limit, Auto-Series & Auto-Parallel Operation.	625.00
810B*	0- 60	0-7.5	0.02%	1.0	100	Variable Voltage and Current Limit, Auto-Series & Auto-Parallel Operation.	795.00
814A*	0- 36	0-25	0.03%	1.0	50	Variable current limit, Auto-Series & Auto-Parallel Operation.	775.00
850	0- 15	0-1.0	3MV	0.5	75	Chassis mounting supply—All input and output connections via octal plug.	197.00
855B*	0- 18	0-1.5	0.03%	0.2	50	Adjustable Voltage & Current Limit, Auto-Series & Auto-Parallel Operation.	169.00
865B*	0- 40	0-0.5	0.01%	0.2	50	Adjustable Voltage & Current Limit, Auto-Series & Auto-Parallel Operation.	169.00
880	0-100	0-1.0	0.02%	0.5	50	Rack mounting panels available.	375.00
881A*	0-100	0-1.0	0.02%	0.2	50	Variable current limit, Auto-Series & Auto-Parallel Operation.	475.00
890A	0-320	0-0.6	0.007%	2.0	100		445.00
895A	0-320	0-1.5	0.01%	3.0	100	Convection cooling, no moving parts—Fuse blows for severe overloads.	625.00
896A	75-160	0-2.5	0.02%	1	100		675.00
6224A*	0- 18	0-3	0.03%	0.5	50	Adjustable voltage and current limits; Auto-Series & Auto-Parallel Operation; <i>-hp-</i> modular cabinet.	295.00
6242A*	0- 32 or 0- 60	0-2 or 0-1	0.02%	1	50	Variable current limit, Auto-Series & Auto-Parallel Operation.	349.00
6346A	0- 36	0-0.15	0.02%	1	50	Chassis plug-in; input, output, and all control by way of 11-pin plug.	120.00
6455A	0- 36	0-75	0.5% combined	180	50 ms	Variable current limit, Auto-Series & Auto-Parallel Operation—High efficiency.	1450.00

Time required for output voltage recovery to within "N" millivolts of nominal output voltage, where "N" is load regulation and nominal output voltage is defined as mean between no load and full load voltages.

* Can be operated as either constant voltage or constant current source.

Data subject to change without notice. Prices F.O.B. factory.