



A New SWR Meter with High Gain-Stability

ONE of the important instruments in the microwave measurement area is basically an audio-frequency instrument known as a Standing Wave Indicator or SWR Meter. This instrument is essentially a very high gain ($\gg 100$ db) audio amplifier which is tuned to achieve high selectivity and which has an output meter calibrated for standing-wave work. Although the instrument was originally intended for use with a slotted line section to measure vswr, it has seen increasing importance in microwave attenuation measurements using audio substitution techniques. It is calibrated for and normally used with a square-law rf detector, but its high sensitivity and single acceptance frequency also make it valuable as a detector for audio frequency bridges.

A new SWR Meter has now been designed which incorporates advances that not only make vswr measurements easier and more accurate to perform than

heretofore but also increase the suitability of this type of instrument for rf attenuation measurements. The new instrument is tunable over a 5% range so as to accommodate the tolerances and drift that are often encountered in modulating frequency. At the same time it has a selectivity that is variable from 15 to 100 cps to meet a variety of measurement conditions varying from highest discrimination against noise to fast amplitude response for swept-frequency measurements.

For attenuation-measuring situations, the instrument is further designed to give high and constant resolution over its complete measurement range. This is achieved by arranging for each 2.5-db section of the normal 10 db meter scale to be expanded to occupy a full meter scale length and one that is roughly linear for high readability. The arrangement is such that 31.5 db of attenuation can be measured with as



Fig. 1. New -hp- Model 415C SWR Meters being used in swept-frequency set-up to check directional coupler performance on broadband basis. Variable bandwidth of new SWR Meter permits sweep rates fast enough to achieve continuous oscilloscope display. New Meter is transistorized and has no-blind-spot "expand" feature to facilitate high-resolution attenuation measurements.

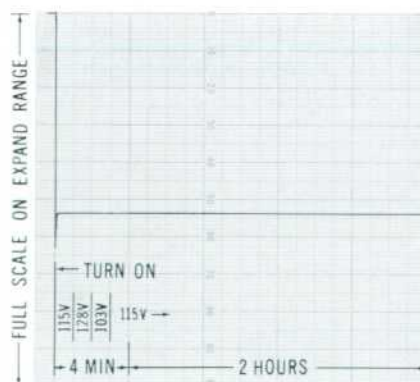

Fig. 2. Combined turn-on and line-voltage record made of typical Model 415C SWR Meter. Record was made in "expand" mode of operation, i.e., in condition demanding highest 415C stability. Record can be read to at least 1% and shows that SWR Meter stability under wide range of conditions approaches 0.01 to 0.02 db.

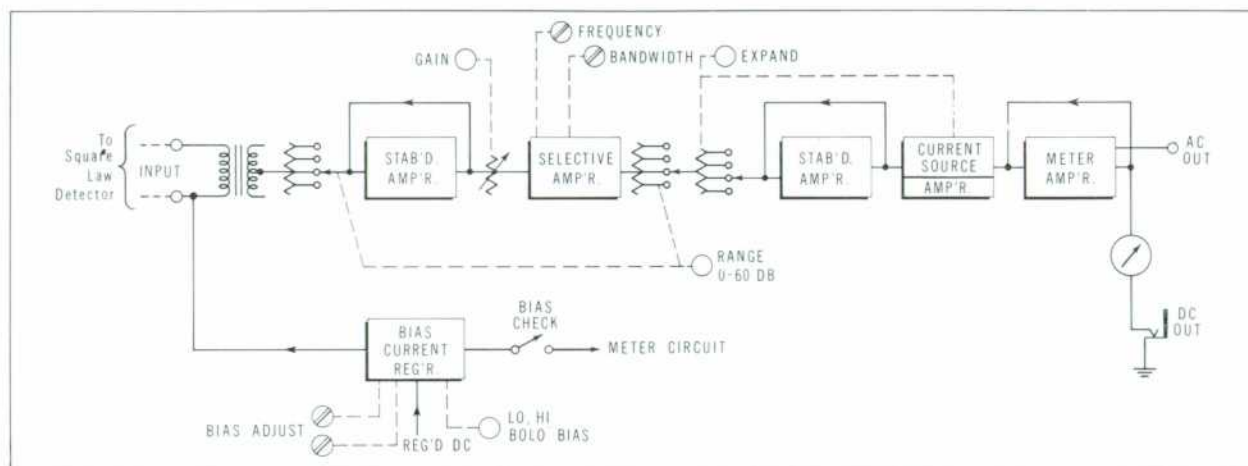

Fig. 3. Basic circuit arrangement of new *hp*-Model 415C SWR Meter.

much resolution as 1.5 db and is one that has no blind spots.

A number of other features of interest are also incorporated. For example, the instrument provides both a dc output for such uses as operating a dc strip-chart recorder and an ac output so that the instrument can be used as a 1,000-cps amplifier of up to 140 db of gain. Conveniences are also provided to simplify operating with either high- or low-current bolometer elements. The instrument provides 8.7 or 4.3 ma to external bolometer elements and these currents can be monitored on the front panel meter. The bias currents can also be adjusted over a $\pm 10\%$ range to meet varying requirements. Bolometer protection is provided against connection and switching surges.

The unit is transistorized to achieve portability and associated physical advantages and to eliminate warm-up drift. It can also be battery-operated which is of value if a measurement set-up is troubled with ground-loop difficulties.

It is also of interest that the indicating meter in the new SWR Meter is equipped with a custom scale prepared on the *hp*-meter calibrator.

CIRCUIT ARRANGEMENT

The overall design approach used for the new SWR Meter is shown in Fig. 3. Despite the very high net gain of the circuit, large amounts of feedback have nevertheless been used to insure high overall gain sta-

bility. The overall net gain is 140 db or more although calibrating the instrument for use with a square-law detector reduces this to an apparent range of 70 db.

The input circuit is arranged to match either 200-ohm bolometer elements or high-impedance (200 kilohm) crystal detectors such as the *hp*-420 and 421 series. The high-impedance input also makes the instrument valuable as a sensitive null detector for bridges. The 200-ohm input impedance is available in three different ways:

- with no bolometer bias current.
- with a bias current of 4.3 ma into a 200-ohm bolometer.
- with a bias current of 8.7 ma into a 200-ohm bolometer.

The bias current is provided by a regulator which includes protective circuits such that connection and switching transients will not burn out the bolometer. The regulator is also arranged so that the current flowing in the bolometer can be read on the panel indicating meter and adjusted by means of rear-panel controls.

The amplifying portions of the circuit are divided into several sections with liberal use of feedback to obtain the high stability and in some cases to control impedances such as at the first amplifier input. Selectivity is achieved for the overall circuit by the use of a passive filter which gives high overall stability with time and

temperature and avoids the instability problems that often occur with active filters. The center frequency of the filter is adjustable by a recessed front-panel control over a 50 cps range, while the bandwidth is similarly adjustable over a 15 to 100 cps or more range. Filters for center frequencies in the region from 400 to 2500 cps are also obtainable.

The current source preceding the meter circuit provides the stable offset current needed for the "expand" mode of operation described later. The meter circuit, besides providing the linear rectification needed for operating the dc indicating meter, also provides an output for operating dc recorders. Of considerable convenience for many instances, this recorder output has one side grounded so that single-ended recorders can be used. This output provides 1 ma into 1500 ohms or less. An ac output is also provided so that the overall instrument can be used as a very high gain tuned amplifier. The ac output provides 1 volt across 10 kilohms or more and also has one side grounded.

HIGH RESOLUTION EXPAND SCALES

In order for an SWR Meter to be of substantial value in making attenuation measurements, it is obviously necessary that it have high resolution over any portion of the attenuation range. It is also desirable that it have approximately constant



Fig. 4. New -hp- Model 415C SWR Meter is only 8 inches wide and 7 inches high. Indicating meter is individually calibrated on -hp- servo-calibrating machine.

resolution throughout the attenuation range so that measurement accuracy will be as independent of magnitude as possible.

These requirements have been met by the design of the new "expand" circuits contained in the SWR Meter. High resolution has been obtained by arranging for each 2.5-db portion of the normal 10-db scale to be expandable into a full meter scale. An example of how the 5 to 7.5-db portion of the 10-db scale is expandable to full scale is shown in Fig. 5. It can be seen that this expanded scale (0-2.5 db) has approximately constant resolution. Each sector of the normal 0-10 db range is also automatically normalized upon expansion so that the instrument can be switched from any normal range to any expanded range without losing the initial reference reading value. The expansion arrangement is thus such that high resolution is obtained in measuring any attenuation value within the dynamic range of the particular detector used and there are no blind spots that cannot be expanded. The resolution of the expanded scale on the meter face is such that it can be read within about 0.01 to 0.02 db anywhere on the scale. The expansion control knob is calibrated to show which 2.5-db sector endpoint is normalized to full scale. This enables direct readout on expanded ranges, since the attenuation value measured is merely the sum of the readings of the range control, the expansion

control, and the expanded meter scale reading.

SWEEP FREQUENCY USAGE

RF attenuation can also be measured on a swept-frequency basis with the new SWR Meter as shown in Fig. 1 (front page). Here the attenuation or coupling of a directional coupler is being measured. Similarly, Fig. 6 shows an arrangement using the SWR Meter in a rapid-sweep, single-coupler reflectometer* for observing the effect of tuning adjustments on a load under test. The wide bandwidth capability of the SWR Meter permits sweep rates fast enough to present a continuous information display on an

*J. K. Hunton and Elmer Lorence, "Improved Sweep Frequency Techniques for Broadband Microwave Testing," Hewlett-Packard Journal, Vol. 12, No. 4, December, 1960.

Fig. 5. Drawing showing operation of "expand" feature. Reading on regular 0-10 db scale (lower) can be expanded to 0-2.5 db "expand" scale (upper) by panel control which also normalizes readings so that reference is always maintained. Reading of approx. 6 db on lower scale is found to be 6.18 db using expansion feature.

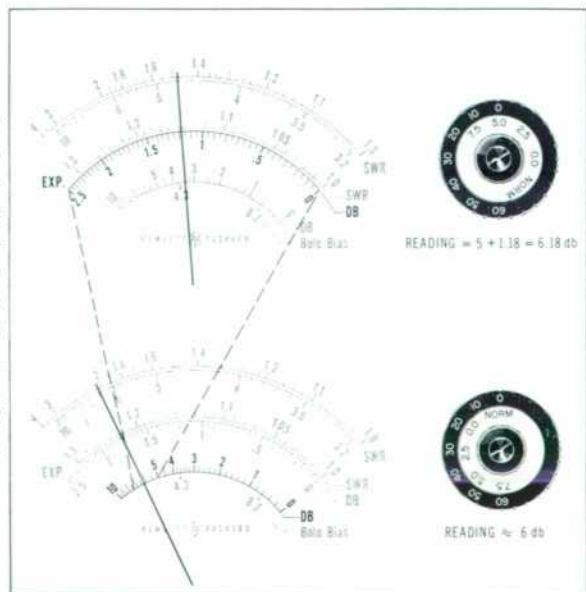

oscilloscope without loss of fine structure of the swept information. Calibration lines may be marked on the oscilloscope graticule with wax pencil so that go-no go indications may be observed by production personnel.

HIGH GAIN-STABILITY

The accuracy with which either a vswr or an attenuation measurement can be made is directly dependent on the gain stability of the SWR Meter. Traditionally, one of the most time-consuming tasks in using SWR Meters has been the constant setting and checking of reference levels. This has been necessary because gain "drift" during a measurement causes a first order error and SWR Meters have often been troubled with such drift for one or more of the following reasons:

1. Changes of gain with line voltage changes.
2. Frequency instability in the instrument filter circuits.
3. Drift with line voltage fluctuations in the expand offset current.

The result of a gain-stability check on the new SWR Meter which is noteworthy in that it was made on an *expanded* range is shown in Fig. 2. In this check a constant signal level was applied to the SWR Meter

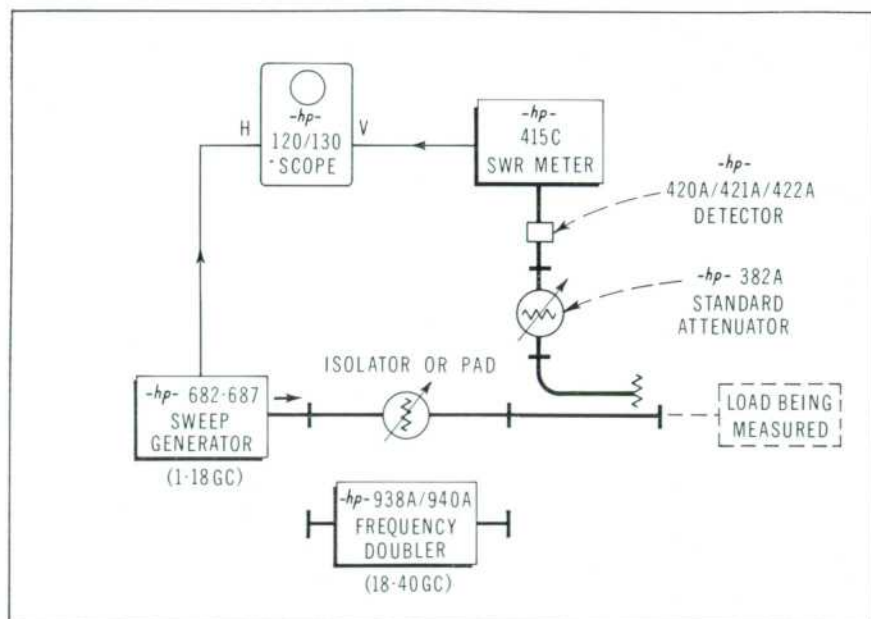

Fig. 6. Equipment arrangement for forming swept-frequency single-coupler reflectometer using new SWR Meter as high-gain amplifier.

while the instrument was turned on from a "cold" start at room temperature. During the first four minutes the line voltage was changed and for the following several hours the SWR Meter was operated at constant line voltage to show longer term stability. The recording can be read to better than 1% of full scale and throughout the test it can be seen that no perceptible changes occurred. The record very emphatically shows that considerable time can be saved in using this transistorized instrument, since no warm-up time is required for stable gain and line-voltage excursions of $\pm 10\%$ do not influence the measurement results.

SERVO-CALIBRATED METERS

One of the factors that influence the accuracy of a test instrument is the accuracy of the readout device. In the case of the SWR Meter, this device is a D'Arsonval type indicating meter. As was described in a recent article*, such meters are generally equipped with pre-calibrated meter scales. Such scales, however, generally place the meter tracking linearity below the capability of

each individual meter movement. As a result, the -hp- laboratories developed a special meter calibrating machine which calibrates an individual meter face and thereby reduces tracking error to below $\frac{1}{2}\%$. Such a calibration procedure is used for the meters in the new SWR Meter not only to achieve high accuracy but to obtain the benefits of a 100% quality inspection test that is inherent in the -hp- calibration process.

BATTERY OPERATION

The power supply circuits in the instrument provide an extremely

well regulated voltage and are temperature-compensated so that the precise offset current required for accurate expand operation will be constant with temperature. Accurate scale normalization and accurate tracking on the expand scales are thus assured.

The power supply also provides charge circuits for use with an optional battery pack, and space is provided in the instrument for such a pack. Battery operation not only provides for portable and remote use of the instrument but also eliminates measurement set-up ground loops. In battery-operated applications it is recommended that the instrument be operated for about 16 hours on recharge after each 8 hours of battery operation. This procedure will maintain the battery at full charge. When fully charged, the battery is normally capable of continuously operating the instrument for up to 36 hours.

ACKNOWLEDGMENT

The electrical design and development group for the new SWR Meter included Thomas H. Clark, Charles W. Cook, Orthell T. Dennison, and the undersigned. Production engineering was done by William R. Hanisch and Don A. Wick.

—Darwin L. Howard

SPECIFICATIONS

-hp- MODEL 415C SWR METER

Frequency: 1000 cps, adjustable 5%; special order frequencies available between 400 and 2500 cps.

Bandwidth: Variable, nominally 15 to 100 cps.

Sensitivity: 0.1 μ V rms for full scale deflection at 30 cps bandwidth over 25° — 55°C range.

Noise: 5 db below full scale with 0.1 μ V rms sensitivity and minimum bandwidth.

Range: 70 db in 10 and 2.5 db steps.

Accuracy: ± 0.1 db/10 db step, maximum cumulative ± 0.2 db; ± 0.1 db when switching from any 10 db step (NORM) to any 2.5 db step (EXPAND), except ± 0.05 db when switching to 0.0 (EXPAND); ± 0.02 db linearity on EXPAND scales.

Input: for use with crystals or bolometers. Crystal: 200 ohms and 200K ohms input impedance.

Bolometer: 200 ohms input impedance; bias provided for 8.7 ma (high) and 4.3 ma (low) bolometers; bias variable $\pm 10\%$; positive bolometer protection. Type BNC input connector.

Output: DC: 0-1 ma into 1500 ohms maximum at the recorder jack (one side grounded).

AC: 0-1 V rms into 10 K ohms minimum at the AC output terminals (one side grounded).

Meter Scales: Calibrated for square law detectors.

SWR: 1-4, 3.2-10, 1-1.3 (expand).

DB: 0-10, 0-2.5 (expand).

Bolo Current: 8.7 ma, 4.3 ma.

Power: 115/230 volts $\pm 10\%$, 50-1000 cps, 2 watts. Power line frequency or multiples thereof must not be at the tuned amplifier frequency. Optional 24 V nom. rechargeable battery available for operating up to 36 hours continuously. Battery designed for installation in the 415C.

Dimensions: 6 1/2" high, 7 3/4" wide, 12" deep.

Weight: 8 lbs.; 11 lbs. with battery.

Accessories Furnished: 7 foot power cord set, -hp- 8120-0078.

Price: -hp- Model 415C SWR Meter, \$325.00 f.o.b. Palo Alto, California.

Accessories Available:

Option 1: Rechargeable battery, installed \$100.00.

Option 2: Additional input connector mounted on the rear panel and wired in parallel with the front panel connector, \$15.00.

Data subject to change without notice.

*Bernard M. Oliver, "Increased Accuracy in -hp- Meters through Servo Calibrating Methods," Hewlett-Packard Journal, Vol. 12, No. 7, March, 1961.