

Direct Capacity Measurement¹

By GEORGE A. CAMPBELL

SYNOPSIS: Direct capacity, direct admittance and direct impedance are defined as the branch constants of the particular direct network which is equivalent to any given electrical system. Typical methods of measuring these direct constants are described with especial reference to direct admittance; the substitution alternating current bridge method, due to Colpitts, is the preferred method, and for this suitable variable capacities and conductances are described, and shielding is recommended. Proposed methods are also described involving the introduction of electron tubes into the measuring set, which will reduce the measurement to a single setting or deflection. This gives an alternating current method which is comparable with Maxwell's single null-setting cyclical charge and discharge method. Special attention is drawn to Maxwell's remarkable method which is entirely ignored by at least most of the modern text-books and handbooks.

THE object of this paper is to emphasize the importance of direct capacity networks; to explain various methods of measuring direct capacities; and to advocate the use of the Colpitts substitution method which has been found preeminently satisfactory under the wide range of conditions arising in the communication field.

About thirty years ago telephone engineers substituted the so-called "mutual capacity" measurement for the established "grounded capacity" measurement; this was a distinct advance, since the transmission efficiency is more closely connected with mutual capacity than with grounded capacity. Mutual capacity, however, can give no information respecting crosstalk, and accordingly, about twenty years ago, I introduced the measurement of "direct capacity" which enabled us to control crosstalk and to determine more completely how telephone circuits will behave under all possible connections.

For making these direct capacity measurements alternating currents of telephone frequencies were introduced so as to determine more exactly the effective value of the capacity in telephonic transmission, and to include the determination of the associated effective direct conductances which immediately assumed great importance upon the introduction of loading.

Telephone cables and other parts of the telephone plant present the problem of measuring capacities which are quite impossible to isolate, but which must be measured, just as they occur, in association with other capacities; and these associated capacities may be much larger than the particular direct capacity which it is neces-

¹ This article is also appearing in the August issue of the *Journal of the Optical Society of America and Review of Scientific Instruments*. An appendix is added here giving proofs of the mathematical results.

sary to accurately measure, and have admittances overwhelmingly larger than the direct conductance, which is often the most important quantity. This is the interesting problem of direct capacity measurement, and distinguishes it from ordinary capacity measurements where isolation of the capacity is secured, or at least assumed.

The substitution alternating current bridge method, suggested to me in 1902 by Mr. E. H. Colpitts as a modification of the potentiometer method, has been in general use by us ever since in all cases where accuracy and ease of manipulation are essential.

After first defining direct capacities and describing various methods for measuring them, this paper will explain how this may all be generalized so as to include both the capacity and conductance components of direct admittances, and the inductance and resistance components of direct impedances.

DEFINITION OF DIRECT CAPACITY

It is a familiar fact that two condensers of capacities C_1 , C_2 , when in parallel or in series, are equivalent to a single capacity ($C_1 + C_2$) or $C_1 C_2 / (C_1 + C_2)$, respectively, directly connecting the two terminals. These equivalent capacities it is proposed to call direct capacities. The rules for determining them may be stated in a form having general applicability, as follows:

Rule 1. The direct capacity which is equivalent to capacities in parallel is equal to their sum.

Rule 2. The direct capacity between two terminals, which is equivalent to two capacities connecting these terminals to a concealed branch-point, is equal to the product of the two capacities divided by the total capacity terminating at the concealed branch-point, *i.e.*, its grounded capacity.

These rules may be used to determine the direct capacities of any network of condensers, with any number of accessible terminals and any number of concealed branch-points. Thus, all concealed branch-points may be initially considered to be accessible, and they are then eliminated one after another by applying these two rules; the final result is independent of the order in which the points are taken; all may, in fact, be eliminated simultaneously by means of determinants²; a network of capacities, directly connecting the accessible terminals, without concealed branch-points or capacities in parallel, is the final result. Fig. 1 shows the two elementary cases of direct capacities and also, as an illustration of a more complicated system, the bridge

² See appendix, section 1, for a discussion of determinant solutions.

circuit, with three corners 1, 2, 3 assumed to be accessible, and the fourth inaccessible, or concealed. Generalizing, we have the following definition:

The direct capacities of an electrical system with n given accessible terminals are defined as the $n(n-1)/2$ capacities which, connected between each pair of terminals, will be the exact equivalent of the system in its external reaction upon any other electrical system with which it is associated only by conductive connections through the accessible terminals.

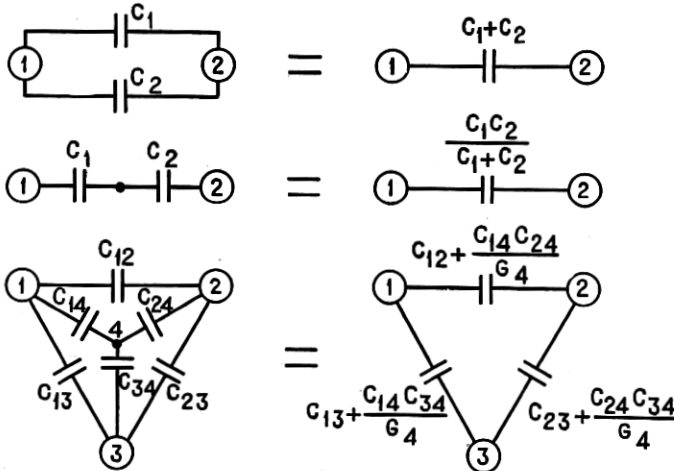

Fig. 1—Equivalent Direct Capacities. $G_4 = C_{14} + C_{24} + C_{34}$ = Grounded Capacity of Branch-Point 4

The total direct capacity between any group of the terminals and all of the remaining accessible terminals, connected together, is called the grounded capacity of the group.

This definition of direct capacity presents the complete set of direct capacities as constituting an exact, symmetrical, realizable physical substitute for the given electrical system for all purposes, including practical applications. Direct capacities are Maxwell's "coefficients of mutual induction," but with the sign reversed, their number being increased so as to include a direct capacity between each pair of terminals.

In considering direct capacities we exclude any direct coupling, either magnetic or electric, from without with the interior of the electrical system, since we have no concern with its internal structure; we are restricted to its accessible, peripheral points or terminals; some care has been taken to emphasize this in the wording of the definition.

ADDITIVE PROPERTY OF DIRECT CAPACITIES

Connecting a capacity between two terminals adds that capacity to the direct capacity between these terminals, and leaves all other direct capacities unchanged. Connecting the terminals of two distinct electrical systems, in pairs, gives a system in which each direct capacity is the sum of the corresponding two direct capacities in the individual systems. Joining two terminals of a single electrical system to form a single terminal adds together the two direct capacities from the two merged terminals to any third terminal, and leaves all other direct capacities unchanged, with the exception of the direct capacity between the two merged terminals, which becomes a short circuit. Combining the terminals into any number of merged groups leaves the total direct capacity between any pair of groups unchanged, and short-circuits all direct capacities within each group.

These several statements of the additive property of direct capacities show the simple manner in which direct capacities are altered under some of the most important external operations which can be made with an electrical network, and explain, in part, the preeminent convenience of direct capacity networks.

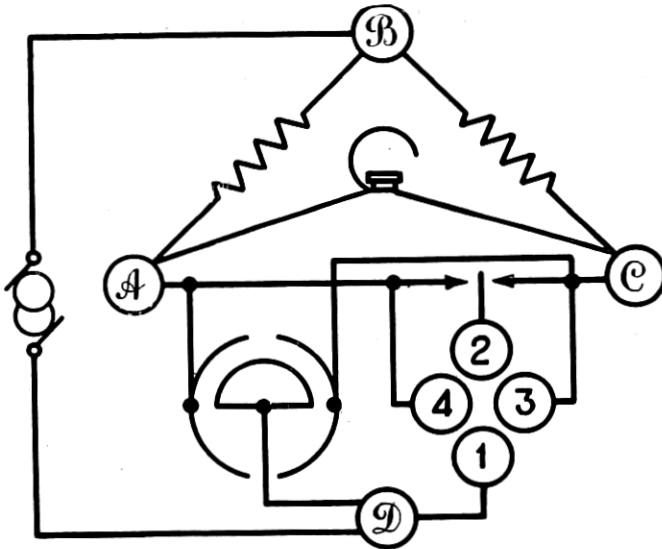

Fig. 2—Colpitts Substitution Bridge Method for Direct Capacity

Since the additive property of direct capacities is sufficient for explaining the different methods of measuring direct capacities we may now, without further general discussion of direct capacities, proceed to the description of the more important methods of measurement.

COLPITTS SUBSTITUTION BRIDGE METHOD, FIG. 2

The unknown direct capacity is shifted from one side of the bridge to the other, and the balance is restored by adjusting the capacity standard so as to shift back an equal amount of direct capacity. The method is therefore a substitution method, and the value of the bridge ratio is not involved. Both the standard and the unknown remain in the bridge for both settings, so that the method involves transposition rather than simple, ordinary substitution.

Details of the method as shown by Fig. 2 are as follows: To measure the direct capacity C_{12} between terminals 1 and 2 connect one terminal (1) to corner \mathcal{D} of the bridge, and adjust for a balance with the other terminal (2) on corner \mathcal{A} and then on \mathcal{C} , while each and every one of the remaining accessible terminals (3, 4, . . .) of the electrical system is permanently connected during the two adjustments to either corner \mathcal{A} or \mathcal{C} . If the direct capacities in the standard condenser between corners \mathcal{A} and \mathcal{D} are C' , C'' in the two balances,

$$C_{12} = C'' - C'$$

and if the bridge ratio is unity³,

$$C_{13} - C_{14} = C' + C'' - 2C_0,$$

where C_0 is the standard condenser reading when the bridge alone is balanced.

Two settings are required by this method for an individual direct capacity measurement, but in the systematic measurement of all the direct capacities in a system the total number of settings tends to equal the total number of capacities, when this number becomes large. The number of settings may always be kept equal to the number of capacities by employing an equality bridge ratio, and using the expression for the direct capacity difference given above. The same remarks also hold for the group of direct capacities connecting any one terminal with all the other terminals.

In general, ground is placed upon corner \mathcal{C} of the bridge, but is transferred to corner \mathcal{D} , if it is connected to one terminal of the required direct capacity. The arbitrary distribution of the other terminals between corners \mathcal{A} and \mathcal{C} may be used to somewhat control the amount of standard capacity required; or it may be helpful in reducing interference from outside sources, when tests are made upon extended circuits. The grounded capacity of a terminal or group of terminals is measured by connecting the group to \mathcal{C} , and all of the remaining terminals together to \mathcal{D} .

³ See appendix, section 2.

The excess of one direct capacity C_{12} over another C_{56} is readily determined by connecting terminals 1 and 5 to corner \mathcal{D} , terminals 3, 4, 7, 8, . . . to corner \mathcal{C} or \mathcal{A} , and then balance with terminals 2 and 6 on \mathcal{A} and \mathcal{C} , respectively, and repeat, with their connections reversed.

POTENTIOMETER METHOD, FIG. 3

The required direct capacity C_{12} is balanced against one of its associated direct capacities, augmented by a standard direct capacity

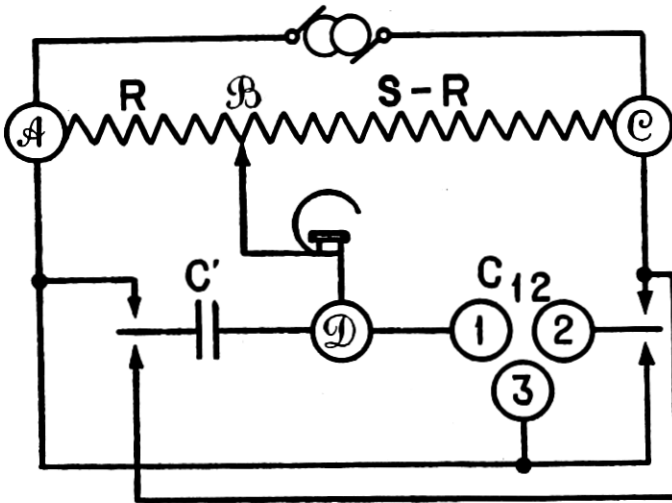

Fig. 3—Potentiometer Method for Direct Capacity

C' , and the measurement is repeated with the required direct capacity and standard interchanged. Let R' , R'' be the resistances required in arm $\mathcal{A}\mathcal{B}$ of the bridge for the first and second balance, then, S being the total slide wire resistance and G_1 the grounded capacity of terminal 1:⁴

$$C_{12} = \frac{R'}{R''} C',$$

$$G_1 = \frac{S - R''}{R''} C'.$$

This ratio method requires for the bridge a variable or slide wire resistance and a constant condenser, and it may be employed as an improvised bridge, when sufficient variable capacity is not available for the Colpitts method. Not being a substitution method, however,

⁴See appendix, section 3.

greater precautions are necessary for accurate results. There must be no initial direct capacity in arm \mathcal{CD} , or a correction will be required. Possibly variable capacity ratio arms would be preferable to resistances.

NULL-IMPEDANCE BRIDGE METHOD FOR DIRECT CAPACITY, FIG. 4

Assuming that the electron tube supplies the means of obtaining an invariable true negative resistance, Fig. 4 shows a method which determines any individual direct capacity from a single bridge setting. The bridge arms are replaced by a Y network made up of two resist-

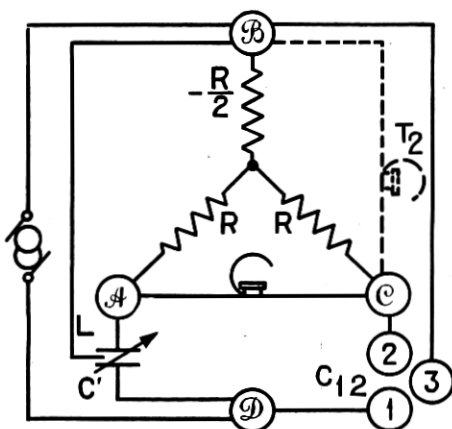

Fig. 4—Null-Impedance Bridge Method for Direct Capacity

ances R , R and a negative resistance $-R/2$; the Y has then a null-impedance between corner \mathcal{B} and corners \mathcal{A} , \mathcal{C} connected together⁵. The three terminals 1, 2, 3 of the network to be measured are connected to corners \mathcal{D} , \mathcal{C} , \mathcal{B} and a balance obtained by adjusting the variable standard condenser C' . Then $C_{12} = C'$ regardless of the direct capacities associated with C_{12} and C' , since these capacities either are short-circuited between corners \mathcal{B} , \mathcal{A} or \mathcal{B} , \mathcal{C} or are between corners \mathcal{B} , \mathcal{D} and thus outside of the bridge.

Correct adjustment of the negative resistance may be checked by observing whether there is silence in telephone T_2 after the balance has been obtained. Assuming invariable negative resistance, this test need be made only when the bridge is set up, or there is a change in frequency. The bridge may be given any ratio Z_1/Z_2 by employing a Y made up of impedances Z_1 , Z_2 , and $-Z_1 Z_2/(Z_1 + Z_2)$.

⁵ See appendix, section 4, which also describes a transformer substitute for the Y.

MAXWELL DISCHARGE METHOD⁶, FIG. 5

Connect the terminals between which the direct capacity C_{12} is required, to A , B and the remaining accessible terminals of this electrical system to D . The adjustable standard capacity is C' and any associated direct capacities in this standard are shown as C'' ,

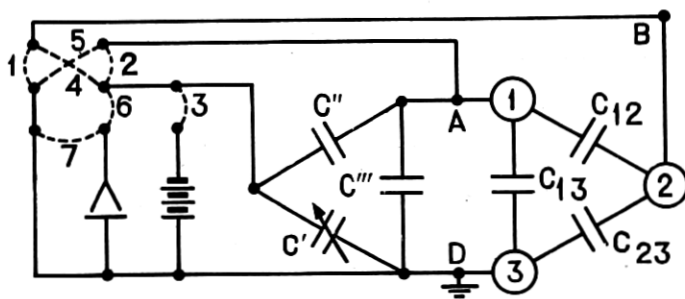

Fig. 5—Maxwell Discharge Method for Direct Capacity

C''' . If C_{12} is a direct capacity to ground, interchange C' and C_{12} . Balancing involves the following repeated cycle of operations:

1. Make connections 1, 2, 3 and 7 for an instant (thus charging C_{12} , C_{13} , C''' , C' and discharging the electrometer).
2. Make connections 4, 5 and then 6 (to discharge condensers C_{13} , C''' , mix charges of C_{12} , C' with polarities opposed and connect electrometer).
3. Adjust C' to reduce the electrometer deflection when the cycle is again repeated.

When a null deflection is obtained $C_{12} = C'$; the required direct capacity is equal to the standard direct capacity irrespective of the magnitudes of the four associated direct capacities. If all capacities are free of leakage and absorption, this remarkable method accurately compares two direct capacities by means of a single null setting, and it requires the irreducible minimum amount of apparatus.

BALANCED-TERMINAL CAPACITY MEASUREMENT, FIG. 6

This is defined as the direct capacity between two given terminals with all other terminals left floating and ignored, after a hypothetical redistribution of the total direct capacity from the given pair of terminals to every third terminal which balances the two sides of the pair. The balanced-terminal capacity, as thus defined, is equal to the direct capacity between the pair augmented by one-quarter of

⁶ Electricity and Magnetism, v. 1, p. 350 (ed. 1892).

the grounded capacity of the pair, neither of which is changed by the assumed method of balancing.

As illustrated in Fig. 6, terminals 1, 2 are the given pair and terminal 3 includes all others, assumed to be connected together. A bridge ratio of unity is employed, and the entire bridge is shielded from ground with the exception of corners C , D which are initially balanced

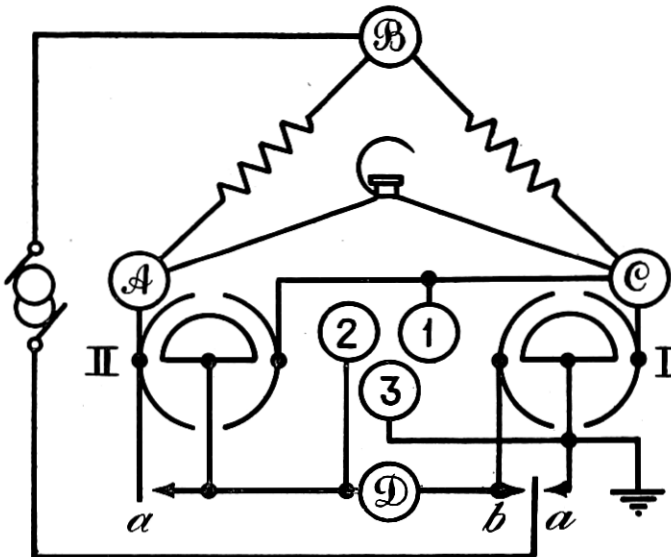

Fig. 6—Bridge for Determining Hypothetical Capacity Between Two Terminals with Other Terminals Balanced and Ignored

to ground within the range of variable condenser I . The following two successive balances are made:

1. With contacts a , a' closed and b open, balance is secured by varying condenser I (the total capacity of which is constant) giving the reading C' for its direct capacity in parallel with terminals 1, 3.
2. With contacts a , a' open and b closed, balance is obtained by varying condenser II , obtaining the reading C'' for its direct capacity in AD .

If C'_o , C''_o are the corresponding readings without the network, the balanced-terminal capacity C_b and the grounded capacity unbalance of the given pair of terminals are:⁷

$$C_b = 2(C'' - C''_o),$$

$$G_2 - G_1 = 2(C' - C'_o).$$

⁷ See appendix, section 5.

Any failure to adjust condenser I to perfectly balance the given pair of terminals will decrease the measured capacity C_b . This fact may be utilized to measure the capacity with the second bridge arrangement alone (contacts a, a' open and b closed) by adjusting condenser I so as to make the reading C'' of condenser II a maximum. This procedure presents no difficulty, since the correct setting for condenser I lies midway between its two possible settings for a balance with any given setting of condenser II ; furthermore, C'' is not sensitive to small deviations from a true balance in C' .

Balanced-terminal capacity is of practical importance as a measure of the transmission efficiency to be expected from a metallic circuit, if it is subsequently transposed so as to balance it to every other conductor. In practice, when the unbalance of the section of open wire or cable pair, which is being measured, is relatively small, it is sufficient to set condenser I , once for all, to balance the bridge itself and ignore the unbalance of the pair. This favors an unbalanced pair, however, by the amount $(G_2 - G_1)^2/4 (G_{12} + G_{CD})$ where $G_{12} + G_{CD}$ is the grounded capacity of the pair augmented by that of the bridge.⁸ For rapid working, condenser II is graduated to read $2C''$ and by auxiliary adjustment C'_o is made zero, so that the required capacity is read directly from the balance.

ADDITIONAL METHODS OF MEASURING DIRECT CAPACITY

Measurement of the capacity between the terminals, taken in pairs with all the remaining terminals left insulated or floating, gives $n(n - 1)/2$ independent results, from which all the direct capacities may be derived by calculation of certain determinants⁹. Practically, however, we are in general interested in determining individual direct capacities from the smallest possible number of measurements, and the first step is naturally to connect all of the remaining conductors together, so as to reduce the system to two direct capacities in addition to the one the value of which is required. Three measurements are then the maximum number required, and we know that two, or even one, is sufficient if particular devices are employed.

The three measurement method of determining direct capacities from the grounded capacities of the two terminals taken separately G_1, G_2 , and together G_{12} , is given by Maxwell.¹⁰ If $G_1 = C'$, $G_{12} = C' + C''$, and $G_2 = C'' + C'''$,

⁸ See appendix, section 6.

⁹ See appendix, section 7.

¹⁰ *Ibid.*, p. 110.

then

$$\begin{aligned} C_{12} &= \frac{1}{2} (G_1 + G_2 - G_{12}) \\ &= \frac{1}{2} C''' \end{aligned}$$

which indicates a method by which large grounded capacities can be balanced against three variable capacities, only one of which need be calibrated, and that one need be no larger than the required direct capacity.

Two-setting methods, as illustrated by the Colpitts and potentiometer methods, rest upon the possibility of connecting one of the associated direct capacities between opposite corners of the bridge where it is without influence on the balance, and not altering any associated direct capacity introduced into the working arms of the bridge. Numerous variations of these methods have been considered which may present advantages under special circumstances. Thus, if conductors 1, 2, 3 of Fig. 7 are in commercial operation, and it is not permissible to directly connect two of them together, a double bridge might be employed with a testing frequency differing from

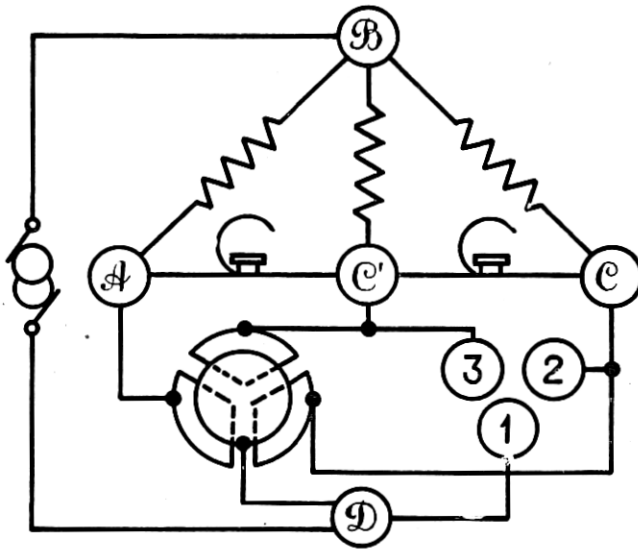

Fig. 7—Double Bridge for Direct Capacity

that of operation. A telephone is shown for each ear, and a constant total direct capacity is divided between the three branches in the proportion required to silence both telephones.

One-setting methods attained ideal simplicity in the Maxwell discharge method, but we found it necessary to use alternating current

methods, and here negative resistances make a one-setting method at least theoretically possible, as explained above. Of possible variations it will be sufficient to refer to the ammeter method Fig. 8. Termi-

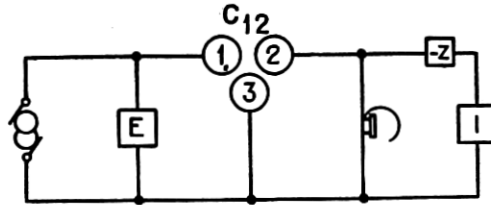

Fig. 8—Ammeter Circuit for Determining Direct Capacity

nals 1 and 2 of the required direct capacity C_{12} are connected to the voltmeter and ammeter terminals, respectively, and all other terminals go to the junction point at 3. Then

$$C_{12} = \frac{I}{2\pi f E},$$

provided the ammeter actually has negligible impedance. The method is well adapted for rapid commercial testing. The ammeter impedance may be reduced to zero by a variable negative impedance device ($-Z$), adjusted to reduce the shunted telephone to silence.

SHIELDING

In the discussion of the bridge, it has been assumed that the several pieces of apparatus forming the six branches of the bridge have no mutual electrical or magnetic reaction upon each other, except as indicated. In general, however, a balance will be upset by changes in position of the pieces of apparatus, or even by movements of the observer himself, whereas these motions cannot affect any of the mutual reactions which have been explicitly considered. The skillful experimenter, understanding how these variations are produced by the extended electric and magnetic fields, will anticipate this trouble and take the necessary precautions, possibly without slowing down his rate of progress.

Where hundreds of thousands of measurements are to be made, however, substantial savings are effected by arranging the bridge so that reliable measurements can be made by unskilled observers, and here it is necessary to shield the bridge so that any possible movements of the observer and of the apparatus will not affect the results. Magnetic fields of transformers are minimized by using toroidal coils with iron cases. Electrostatic fields are shielded by copper cases;

the principles of shielding were explained in an earlier paper,¹¹ Fig. 13 of that paper showing the complete shielding of the balance as constructed for the measurement of direct capacity by the Colpitts method. Over five million capacity and conductance measurements have been made with the shielded capacity and conductance bridge and in a forthcoming paper Mr. G. A. Anderegg will give details of actual construction of apparatus and of methods of operation as well as some actual representative results.

DIRECT ADMITTANCE MEASUREMENTS

For simplicity, the preceding definitions and methods of measurement have been described in terms of capacity, but everything may be generalized, with minor changes only, for the definition and measurement of direct admittances with their capacity and conductance components. The essential apparatus change is the addition, in parallel with the variable capacity standards employed, of a variable conductance standard, which shifts direct conductance from one side of the bridge to the other, without changing the total reactance and conductance in the two sides of the bridge. This may be practically realized in a great variety of ways as regards details, which it will suffice to illustrate by Fig. 9, where C' , C'' , C''' , G' , G'' , indicate the

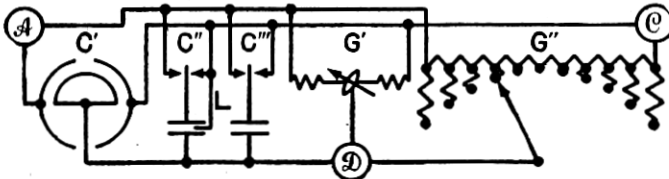

Fig. 9—Variable Direct Conductance and Capacity Standard for Direct Admittance Bridge

continuously variable capacity and conductance standards with enough step-by-step extensions to secure any desired range.

For the continuously variable conductance standard a slide wire is represented, with a slider made up of two hyperbolic arcs so proportioned that, as the slider is moved uniformly in a given oblique direction, conductance is added uniformly on the left and just enough of the wire is short-circuited to produce an equal conductance decrease on the other side. The arcs are portions of the hyperbola $xy = (L^2 - S^2)/4$, where L , S are the total length of the wire and of the portion to be traversed by the slider, and the coordinate axes are

¹¹ The Shielded Balance, *El. W.*, 43, 1904 (647-649).

the slide wire and the direction of the motion of the slider as oblique asymptotic axes.¹² $L = GS/g = 4G/\rho(G^2 - g^2)$, where G is the total conductance and $(G \pm g)/2$ the limiting direct conductance on either side.

If an ordinary slider replaces the hyperbolic arc slider, and the scale reading is made non-uniform so as to give one-half of the difference between the direct conductances \mathcal{A} to \mathcal{D} and \mathcal{C} to \mathcal{D} , the conductance standard will still give absolutely correct results with the Colpitts method, provided the bridge ratio is unity. This simplification in connection with the balancing capacity I of Fig. 6 would, however, not be strictly allowable. For improvised testing we have found it sufficient to use two equal resistances (R) with a dial resistance (r) in series with one of them, and take the defect of conductance introduced by the dial resistance as equal to r/R^2 or to $10^{-2}r$, $10^{-1}r$, r , micromho according as R was made 10000, 3162, or 1000 ohms.¹³

For a step-by-step conductance standard, Fig. 9 shows a set of 10 equal resistances, connected in series between corners \mathcal{A} , \mathcal{C} , to the junction points of which there is connected a parabolic fringe of resistances, the largest of which is 2.5 times each of the ten resistances. With this arrangement the direct conductance in $\mathcal{A}\mathcal{D}$ may be adjusted by ten equal steps, beginning with zero, while the conductance in $\mathcal{C}\mathcal{D}$ is decreased by equal amounts to zero. The total resistance required for this conductance standard is only 21/25 of the resistance required to make a single isolated conductance equal to one of the ten conductance steps; the ratio may be reduced to 1/2 by doubling the number of contacts,¹⁴ and using one fringe resistance for all positions. Resistance may be still further economized by using as high a total conductance as is permissible in the bridge, and securing the required shift in conductance from a small central portion of the parabolic fringe.

Fig. 9 shows the variable capacity standards as well as the variable conductance standards and a few practical points connected with the capacity standards may be mentioned here.

The revolving air condenser standard has two fixed plates connected to \mathcal{A} and \mathcal{C} , so that the capacity will increase as rapidly on one side as it decreases on the other side. Since perfect constancy of the total capacity is not to be expected, on account of lack of perfect mechanical uniformity, the revolving condenser should be calibrated to read

¹² See appendix, section 8.

¹³ See appendix, section 9.

¹⁴ See appendix, section 10.

one-half of the difference between the capacities on the two sides, as explained above in connection with conductance. The capacity sections employed to extend the range of the revolving condenser include both air condensers C' and mica condensers C'' , the latter being calibrated by means of the air condensers and the conductance standard.

A novel feature of our standard air condensers is a third terminal called the leakage terminal, and indicated at L in Figs. 4, 9. Attached to it are plates so arranged that all leakages either over, or through, the dielectric supports from either of the two main terminals, must pass to the leakage terminal. There can be no leakage directly from one of the main terminals to the other. There is thus no phase angle defect in the standard direct capacity due to leakage, and that due to dielectric hysteresis in the insulating material is reduced to a negligible amount by extending the leakage plates beyond the dielectric, so as to intercept practically all lines of induction passing through any support. This leakage terminal is connected to corner C of the bridge; in the revolving condensers, it is one of the fixed plates.

DIRECT IMPEDANCE MEASUREMENTS

The reciprocal of a direct admittance is naturally termed a direct impedance; substituting impedance for capacity, the definition of direct capacity, given above, becomes the definition of direct impedance. The complete set of direct impedances constitutes an exact, symmetrical, physical substitute for any given electrical system. Direct impedances are often, in whole or in part, the most convenient constants since many electrical networks are made up of, or approximate to, directly connected resistances and inductances. To make direct impedance measurements which will not involve the calculation of reciprocals, we naturally employ inductance and resistance standards in series, the associated direct impedances being eliminated as with direct capacities.

CONCLUSION

It has been necessary to preface the description of methods of measuring direct capacities by definitions and a brief discussion, since direct capacities receive but scant attention in text-books and hand-books. By presenting direct capacities, direct admittances, and direct impedances as alternative methods of stating the constants of the same direct network, employed as an equivalent substitute for any given electrical system, it is believed the discussion and measure-

ment of networks has been simplified. In another paper the terminology for admittances and impedances will be still further considered, together with their analytical correlation.

APPENDIX

In explaining the different methods of measuring direct capacities it is necessary to start with a clear idea of what direct capacities are, and to make use of the additive property, but it is not necessary to go into any comprehensive discussion of direct capacities. Accordingly, the mathematical treatment of direct capacities has been reserved for another paper, but it seems desirable to append to the present paper proofs of the analytical results given in this paper, since the method of approach giving the simplest proof is not always perfectly obvious.

(1) Reducing the number of terminals which are considered accessible, by ignoring terminals p, q, r, \dots , changes the direct and grounded capacities from (C_{ij}, G_i) to (C'_{ij}, G'_i) , the latter being expressed in terms of the former as follows:

$$C'_{ij} = \frac{\begin{vmatrix} -C_{ij} - C_{ip} & -C_{iq} & \dots \\ -C_{jp} & G_p & -C_{pq} & \dots \\ -C_{jq} & -C_{pq} & G_q & \dots \\ \dots & \dots & \dots & \dots \end{vmatrix}}{\begin{vmatrix} G_p & -C_{pq} & \dots \\ -C_{pq} & G_q & \dots \\ \dots & \dots & \dots \end{vmatrix}}$$

$$G'_i = -C'_{ii}$$

where C'_{ii} is given by formula above and $G_i = -C_{ii}$.

To check these formulas note that on substituting $(G_i, -C_{ij})$ for Maxwell's (q_{ii}, q_{ij}) in his equations (18)¹⁵ the coefficients form an array in which the grounded capacity G_i is the i th element in the main diagonal and $-C_{ij}$ is the element at the intersection of row i , column j . The array may be supposed to include every terminal symmetrically by considering the earth's potential as being unknown and writing down the redundant equation for the charge on the earth. Let the charge be zero on terminal j and on all concealed terminals; let there be a charge on terminal i and an equal and opposite charge on all the remaining accessible terminals, connected together to form a single terminal k . Now taking the potential of j as the zero of reference

¹⁵ *Ibid.*, p. 108.

and calculating the potentials of i and k and then allowing the direct capacity between j and k to become infinite, the direct capacity between terminals i and j is $C_{ij} = -\text{Lim} (C_{jk} V_k / V_i)$. This gives the above formula for C'_{ij} , with $-C'_{ii}$ as a special case. This method is an electrostatic counterpart of the ammeter method shown in Fig. 8 on page 29.

If there is but one ignored terminal the determinant solution takes on a simple form from which Rules 1 and 2 and Fig. 1 may be checked.

If all but two terminals are ignored the equivalent direct network is reduced to a single direct capacity. When, for each pair of terminals, this capacity C'_{ij} is known, from measurements or from calculations, the direct capacities between the terminals may be derived by means of the following formulas

$$C_{ij} = 2 \frac{D_{ij}}{D}$$

$$G_i = -C_{ii} = -2 \frac{D_{ii}}{D}$$

where D_{ij} is the cofactor of the element in row i column j of the determinant

$$D = \begin{vmatrix} 0 & S_{12} & S_{13} & \dots & 1 \\ S_{12} & 0 & S_{23} & \dots & 1 \\ S_{13} & S_{23} & 0 & \dots & 1 \\ \cdot & \cdot & \cdot & \dots & \cdot \\ 1 & 1 & 1 & \dots & 0 \end{vmatrix}$$

which has zeros in the main diagonal, a border of ones in the last row and column, while the other elements are $S_{ij} = 1/C'_{ij}$, that is, the reciprocals of the given capacities. The S 's form a complete symmetrical system of network constants; Maxwell's coefficients of potential p_{ii} with the two suffixes the same are the same quantities, but he employs only those coefficients of this type which are associated with the earth, his system being completed by adding the coefficients with different suffixes. By starting with Maxwell's results the above formula may be deduced, but more direct proofs, both physical and mathematical, will be given in the theoretical paper referred to at the end of the present paper.

The purpose of this section of the appendix is achieved if the determinant solutions are made so clear as to be available for use in any particular case.

(2) Starting with the bridge alone balanced at reading C° the other two settings involve, in the capacity standard, increases in the direct

capacity on the left of $(C' - C^\circ)$ and $(C'' - C^\circ)$, with equal decreases on the right. Therefore

$$\begin{aligned} C_{12} + C_{14} + (C' - C^\circ) &= - (C' - C^\circ) + C_{13} \\ C_{14} + (C'' - C^\circ) &= - (C'' - C^\circ) + C_{13} + C_{12} \end{aligned}$$

and adding gives the value of $(C_{13} - C_{14})$.

(3) The condition of equal impedance ratios on the two sides, as required for a balance, gives, for both the switches up and down,

$$\begin{aligned} R' (G_1 - C_{12} + C') &= (S - R') C_{12}, \\ R'' G_1 &= (S - R'') C', \end{aligned}$$

respectively, from which the expressions for C_{12} and G_1 follow.

(4) The Y of Fig. 4 has unusual properties because the total conductance connecting the concealed branch-point of the Y to the three bridge corners \mathcal{A} , \mathcal{B} , \mathcal{C} is zero. Thus the conductance between any one corner and the remaining two corners joined together is infinite, or in other words, the Y acts as a short circuit under all these three conditions. On the other hand, if corner \mathcal{A} , \mathcal{B} , or \mathcal{C} is left floating and ignored the conductance between the other two corners is $2/R$, $1/2R$ or $2/R$, respectively, and the Y is not a short circuit. These statements are verified at once by applying the familiar expressions for resistances in parallel and in series.

On account of the unusual behavior of the Y, even when taken alone, it is not immediately apparent how it will affect the operation of the bridge of Fig. 4 with direct capacities between corners $\mathcal{A}\mathcal{B}$ and $\mathcal{B}\mathcal{C}$. For this reason it is highly desirable to find an equivalent network the behavior of which is more readily comprehended. It is not feasible to employ the delta network which is equivalent to the Y for this has indeterminate characteristics, being made up of three infinite conductances, only two of which have the same sign. We may, however, make use of the Y which is equivalent to the original Y and direct capacities C_{AB} and C_{BC} taken together. This is found as follows: Any admittance delta may be replaced by a star having admittances equal to the sum of the products of the delta admittances taken in pairs divided by the opposite delta admittance. Applied to the delta of Fig. 1, we find that the star that is equivalent has the capacities

$$\begin{aligned} C''_{14} &= \frac{S}{C_{24} C_{34} + G_4 C_{23}} \\ C''_{24} &= \frac{S}{C_{34} C_{14} + G_4 C_{13}} \\ C''_{34} &= \frac{S}{C_{14} C_{24} + G_4 C_{12}} \end{aligned}$$

where

$$S = C_{14}C_{24}C_{34} + C_{14}C_{24}(C_{13} + C_{23}) + C_{24}C_{34}(C_{12} + C_{13}) + C_{34}C_{14}(C_{12} + C_{23}) \\ + G_4(C_{12}C_{23} + C_{23}C_{13} + C_{12}C_{13}),$$

which, upon substituting the value of G_4 , is the sum of 16 terms, each of which is the product of three capacities, every combination of three capacities being included except the four cases in which the three capacities would form a closed circuit. By allowing the capacities to be complex quantities, any admittances are covered by the formulas.

If $G_4 = 0$

$$\frac{C''_{14}}{C_{14}} = \frac{C''_{24}}{C_{24}} = \frac{C''_{34}}{C_{34}} = \frac{S}{C_{14}C_{24}C_{34}}$$

or the new Y arms present the same ratios as the original Y arms taken alone; that is, the direct capacities C_{AB} , C_{BC} of Fig. 4 have no effect on the bridge ratio. Thus the constancy of the bridge ratio holds for all null-impedance bridges regardless of the ratio Z_1/Z_2 and of the nature of the direct admittances from corners A and C to B .

If $G_4 = 0$ and also $C_{24} = C_{14}$ and $C_{12} = 0$, then

$$C''_{14} = C''_{24} = -\frac{1}{2}C''_{34} = C_{14} + \frac{1}{2}(C_{13} + C_{23}).$$

Applying this to Fig. 4, which is possible since the bridge ratio is unity, we find that the three arms of the equivalent Y may be considered as being made up of resistances and capacities in parallel. The resistances are R , R , $-R/2$ and the associated capacities C , C , $-2C$, where R is the original resistance in the Y and C is one-half the sum of the two actual direct capacities from \mathcal{B} to \mathcal{P} and from \mathcal{B} to \mathcal{C} . The equivalent bridge thus obtained has ratio arms made up of ordinary resistances and capacities and therefore Fig. 4 used as a bridge can present no unexpected characteristics; the negative resistances and capacities of the equivalent Y merely affect the current supplied to the bridge.

An ideal transformer, if such a device existed, might replace the Y, for it would maintain a constant ratio between the currents in the two windings and act as a short circuit when the bridge is balanced. To determine the error when an actual transformer with impedances Z_p , Z_s , Z_{ps} is employed, take the general expression for the ratio of the capacities derived above which is

$$\frac{C''_{14}}{C''_{24}} = \frac{C_{34}C_{14} + G_4C_{13}}{C_{24}C_{34} + G_4C_{23}}$$

Change to admittances by substituting Y for C and G throughout. Assume the transformer replaced by its equivalent conductance star so that

$$\begin{aligned}
 Y_{14} &= \frac{1}{Z_p + Z_{ps}}, \\
 Y_{24} &= \frac{1}{Z_s + Z_{ps}}, \\
 Y_{34} &= -\frac{1}{Z_{ps}}, \text{ and by addition} \\
 Y_4 &= \frac{Z_{ps}^2 - Z_p Z_s}{(Z_p + Z_{ps})(Z_s + Z_{ps})Z_{ps}}.
 \end{aligned}$$

Substituting these values the expression for the actual ratio of the bridge arms becomes

$$\frac{Y''_{14}}{Y''_{24}} = \frac{Z_s + Z_{ps} + (Z_p Z_s - Z_{ps}^2) Y_{13}}{Z_p + Z_{ps} + (Z_p Z_s - Z_{ps}^2) Y_{23}}.$$

(5) When the bridge alone is balanced at readings C'_o and C''_o , let C_{CD} and G_{CD} be the direct capacity between corners C and \mathcal{D} and the total direct capacity between these corners and ground. Since G_{CD} is balanced, the effective direct capacity between corners C , \mathcal{D} when earth is ignored, is by Fig. 1, $(C_{CD} + G_{CD}/4)$. Now connect the three terminals 1, 2, 3, as shown with direct capacities C_{12} , $G_1 - C_{12}$, $G_2 - C_{12}$; G_1 , G_2 being the grounded capacities of terminals 1 and 2. The first balance with the reading C' requires the equality of the total capacity added on each side, *i.e.*,

$$G_1 - C_{12} + (C' - C'_o) = G_2 - C_{12} - (C' - C'_o)$$

or

$$G_2 - G_1 = 2(C' - C'_o)$$

For the second balance ground may again be considered an ignored terminal, and since terminals 1 and 2 have been balanced to ground, and their total direct capacity to ground is $G_{12} = G_1 + G_2 - 2C_{12}$, the effective direct capacity added to the bridge between corners C and \mathcal{D} is $C_b = C_{12} + G_{12}/4$. Equating the added capacities on the two sides of the bridge when balanced at the reading C'' , we obtain $C_b = 2(C'' - C'_o)$.

The direct capacity between C and \mathcal{D} , when ground is considered an accessible terminal, is assumed to be absolutely independent of the setting of the condenser I . To actually meet this condition will require some attention in the design of the variable condenser.

(6) Here the bridge itself is supposed to have equal direct capacities from corners C and \mathcal{D} to ground, while the added terminals 1 and 2 have different direct capacities to ground, the difference being $(G_1 - G_2)$, while the total direct capacity to ground is $(G_{12} + G_{CD})$. Now two capacities in series may be replaced by their product divided

by their sum, which is equal to one-fourth of the sum minus the square of the difference divided by four times the sum. The correction due to the difference is thus $(G_2 - G_1)^2/4(G_{12} + G_{CD})$, as stated.

(7) These determinants are given at the end of the first paragraph of this appendix. These expressions for the direct capacity are of more special interest in the analytical discussion of networks.

(8) Assume that a wire resistance is to be employed and that a sliding contact is to intercept such an amount of resistance that the equivalent conductance will vary directly with the motion of the slider carrying the contact point. Then if the wire is straight and the intercepted portion is of length x and the slider motion is rectilinear and its extent is y the relation which holds between them is $xy = \text{constant}$, the value of the constant depending upon the units employed.

In the paper it is assumed that the total conductance G , the total shifted conductance g , and the resistance of unit length of the slide wire ρ are given; the total length of wire L and the portion traversed by the slider S are then calculated. The arc employed, for each half of the slider of Fig. 9, extends equally both ways from the vertex to the points where the values of x and y are $(L \pm S)/2$, on the hyperbola $xy = (L^2 - S^2)/4$. Substituting for L and S the values given in the paper, it will be found that this range of x actually gives the range of conductance $(G \pm g)/2$, as required.

(9) The exact defect in conductance is

$$\frac{1}{R} - \frac{1}{R+r} = \frac{r}{R(R+r)} = \frac{r}{R^2} \left(1 - \frac{r}{R} + \dots \right)$$

(10) At mid-point the total conductance due to the five resistances (R) on each side, taken in parallel, is $2/5R$ and to give this same conductance an end fringe must have the resistance $2.5R$. Assume a parabolic fringe having the resistance $(5-n)^2 R/10$ at the point connected to \mathcal{P} and \mathcal{C} by resistances nR and $(10-n)R$. This gives a Y network and by Fig. 1 the equivalent direct conductances are $(10-n)/25R$, $n/25R$, $(5-n)^2/250R$ between $\mathcal{D}\mathcal{P}$, $\mathcal{D}\mathcal{C}$, $\mathcal{P}\mathcal{C}$ respectively. The sum of the first two is constant and the first decreases by equal steps, of $1/25R$ each, to zero as the second increases. The parabolic fringe, therefore, gives the required conductances.

The total resistance in the chain of ten resistances is $10R$, in the fringe $11R$, and in the largest single fringe $2.5R$. With the complete fringe the total required is $(10 + 11)R = 21R$; with a single fringe, subdivided as required, only $(10 + 2.5)R = 12.5R$ is required. Compared with $25R$, which would be required for one of the conductance steps, these resistances are $21/25$ and $1/2$.