

# **CUSTOM SOFTWARE DEVELOPMENT**

**SD 3970 - HEALTH, EDUCATION  
AND SAFETY PACKAGE  
PG-3W038 - ISSUE 1.1**

## SPECIFICATION DOCUMENT

SD 3970 ISSUE 1.1  
BASED ON R2V3 ISSUE 1.4

## HEALTH, EDUCATION AND SAFETY PACKAGE

## FEATURE PACKAGE PG-3W038

**INTRODUCTION**

The purpose of this Custom Development is to provide Deluxe Attendant and Paging features for leading edge customers in the Health, Education and Safety fields. This development package contains the following features.

- Meet-Me Paging
- Malicious Call Trace
- Attendant Direct
- Split Night Service
- Attendant 2-Way Splitting
- Attendant Emergency Alert with Immediate Talk Path
- Emergency Access of Trunks by Attendant
- Attendant Service Observing
- Automatic Termination by Time of Day Restriction
- Time of Day and Calls in Queue Display

**TERMINOLOGY**

**ATTENDANT DIRECT** - A custom feature that allows LDN's, trunk groups or LCOS's to be directed to a specific, user-defined group of attendant consoles.

**ATTENDANT GROUP** - A customer-defined group of one or more attendant consoles to which LDN's, trunk groups or LCOS's may be routed.

**ATTENDANT EMERGENCY ALERT** - A custom feature that allows a station user priority access to an attendant in an emergency situation.

**ACD - Automatic Call Distribution** - Groups of extension numbers may be designated as ACD groups. Incoming calls may then be directed to the group rather than a specific station. The call is then routed to the most available extension in the group. If all members of the group are busy, then instead of busy tone being returned to the caller, the call is placed in a first in first out waiting queue until a group member becomes available. While in queue recorded announcements and music may be provided to the calling party.

**BACKUP COVERAGE POSITION** - A point in a call coverage path assigned to handle coverage for a "Meet-Me" Pager line.

**CHAP - CHANnel Processor** - The 80186 processor on the PCC that controls the channel along with the associated RAM and ROM.

- DCS - Distributed Communications System - This feature allows many PBX's to appear to be part of a single system. Each PBX in the system is called a "node" and "nodes" are connected via private trunks. This arrangement allows certain features to act as if only one system was involved. Stations on one "node" may call stations on another "node" just by dialing the appropriate station number. Certain other station features are termed to be "transparent" when the user may apply the feature to any station in either the same "node" or a different "node" without having to dial any differently. Features which are not "transparent" may only be used within each "node" but not between "nodes".
- HARD HOLD W/MULTI LINE SETS - To put a call on hard hold the user depresses the hold button. The user may now do anything on any other line but may not connect the hard held party onto any other conversation. The user may return to the hard held party by depressing the line button.
- HARD HOLD W/SINGLE LINE SETS - On a single line set to put a party on hard hold they must first be put on soft hold and then a special code must be dialed. Once on hard hold, the party may not be involved in any subsequent call until removed from hard hold by special code or by the original party going on-hook.
- ICI - Incoming Call Information - Each attendant console is equipped with a 4 character alpha-numeric display field. The information in this field varies based on the origin of the incoming call and subsequent attendant control key button depressions.
- LCOS - Line Class of Service - defines the features that a group of lines may access.
- LDN - Listed Directory Number
- "MEET-ME" PAGE LINE - A line associated with a paging device. A page line is an unequipped line which has a unique extension number.
- "MEET-ME" PAGER NUMBER (or PAGE LINE EXTENSION) - A software line number assigned to a System 85® which allows special paging and pickup capability.
- "MEET-ME" PAGE PICKUP - The feature used to answer a call to a page line. The page can be picked up while the page line is "ringing," while the page line's cover point is ringing, or after the cover has answered. A page line does not actually ring, but the caller receives audible ringback.
- NODE - A point in a switching network from which many trunks radiate. It may, or may not be a switching center.
- PCC - Processor Communication Circuit - An RS-232C interface from the System 85® to any device accepting RS-232C format. The hardware circuit pack will be referred to as TN474.
- SOFT HOLD W/MULTI LINE SETS - Multi line sets really don't have a soft hold, but by using the conference button, even though a second line is seized, the held line remains associated with the call and may be added into any new conversation which is established.
- SOFT HOLD W/SINGLE LINE SETS - When a single line set is on a two-party conversation and 'flashes' the other party is put on 'soft hold'. The soft held party is still associated with the original parties line and can be added into any subsequent conversation established on that line.
- TIE TRUNK - A tie trunk is a trunk which is used to interconnect PBX's. This allows systems to be connected in a private network and can be configured to make multiple PBX's appear to be one system.

## DESCRIPTION

### "Meet-Me" Paging

#### *Basic Paging Scenarios*

The following scenarios represent the ways in which "Meet-Me" Paging will be used most often.

#### *Basic Page*

A caller, internal or external, dials an extension assigned as a "Meet-Me" paging number (e.g., 4-1234 or xxx-1234 respectively). The system automatically sends a message over an RS-232C port to a Motorola Tone Pager Unit. The message will consist of the last 4 digits of the station number. This implies that the last 4 digits of all "Meet-Me" page lines must be unique. The Motorola transmitter will send a tone alert to the appropriate pager. The caller will receive ring back. The owner of the pager then may go to any station in the system, including off-premise extensions, dial the appropriate dial access code (e.g., #) and their pager number (e.g., 4-1234) to receive the call. The caller will no longer hear ring back, a 200ms tone will be applied to indicate the call has been answered and the two parties are now connected and may begin the conversation. If the owner is already on another call, they may not flash and dial the dial access code. They must seize a new line. That is, the owner may not retrieve a page with a party on soft hold.

If the owner of the pager is not on site they may dial into the system through a remote access trunk, and then dial the pager number to receive the call (e.g., 282-1711 - Dial Tone - 4-1234). The connection is then made as described above. After the connection is made the pager number is now available for another call.

An attendant console or tie trunk may not be used to retrieve a page call.

#### *Basic Page w/Backup Coverage*

If the page is not retrieved within a specified time period a designated back-up coverage point will begin ringing. The coverage position may now be answered and a message may be taken. During the time while the caller is at the coverage position, the pager number is not available for additional calls.

The coverage position may put the call on hold to allow the caller to wait for an additional period of time. In this case the pager number is not available for additional calls. If the caller does not wish to wait, a message can be taken and the call terminated. When the call is terminated the pager number is again available for additional calls. That is, there is no longer a page call pending for the called party.

If coverage occurs because the "Don't Answer" timer has expired, then the call coverage tone will not be heard by the caller. There are two exceptions to the above rule. First, when the incoming call is on a tie trunk in a DCS environment, coverage tone will be heard by the caller. Second, coverage tone will be heard by the caller if an ACD group is the first point in the coverage path. If the page line has "coverage all", then the call coverage tone will be applied when the call is routed to the coverage position.

If all the coverage positions are busy when the specified time period expires, no coverage will occur. If any coverage position hangs up after the time period has expired and before the call is answered, the call will not go to coverage.

#### *Basic Page w/Backup Coverage and Barge-In*

A caller, internal or external, dials an extension assigned as a "Meet-Me" pager number (e.g., 4-1234). The system will automatically send a message over an RS-232C port to a Motorola Tone Pager unit. The Motorola transmitter will send a tone alert to the appropriate pager. The caller will receive ring-back. If the page is not retrieved after a specified time period a designated backup coverage point will begin ringing. The coverage station may now be answered. If the owner of the pager number attempts to retrieve the page after the backup coverage position has answered, a tone will be heard by all three parties involved. When the tone is complete all three parties will be in a talk state. At this time the backup coverage position may remain on the call or hang-up and release from the call. If the backup coverage position remains on the call the pager number will not be available for another call until they release from the call. Additionally, the paged party may hang up and then reconnect to the paging party by re-dialing the appropriate access codes.

If the caller has been put on hold, and the owner of the pager number barges-in, the caller will hear a tone. After the tone the parties will now be connected and the backup coverage line will be released from the call. The pager number is now available to receive additional calls.

In a key environment, if the coverage position puts a call on hold, and a barge-in happens as described above, the following will occur. The System 85® will send a special command to the key equipment. If the call was on hold the key equipment is dropped from the call. The System 85® will then rearrange the call as a two-party call or three party call, as appropriate. If the coverage point has not put the call on hold, barge-in will not be permitted.

If the backup coverage position is ringing when the owner of the pager number retrieves the call, the coverage position is dropped and the calling party and owner are connected as described in a basic page.

#### *Attendant Scenarios for "Meet-Me" Paging*

If a call comes in to an attendant console and requests to speak to someone with a "Meet-Me" pager number, the following situations are possible:

##### *Attendant Remains on the Call*

The attendant splits away from the original caller and dials the appropriate "Meet-Me" pager number. The system will automatically send a message over an RS-232C port to a Motorola Tone Pager unit. The Motorola transmitter will send a tone alert to the appropriate pager. The attendant receives ring back until the owner of the pager number retrieves the call. At this time, ring back will cease and a tone will be applied to indicate that the connection has been made. The attendant may now release the call and the original caller will be connected with the paged party. If the attendant wishes to stay on the call, they may hit the split key and all three parties will be connected. If the paged party does not retrieve the call within the specified time period, the appropriate backup coverage position will begin ringing. If the coverage position answers and the owner then attempts a barge-in, it will be blocked and the owner will receive busy tone.

An alternative method for the attendant to remain in control of the call is by use of the hold key. After extending to the "Meet-Me" pager number, instead of using the split key, the attendant depresses the hold key. The switch loop is put on hold and the original caller will be connected to ring back. The attendant may go about handling other calls. If the call has not been answered within 30 seconds the ring lamp for the switch loop on hold will begin to flash. To return to the call the attendant need only depress the associated switch loop key. If the call is answered by either the page owner or the coverage point the ring lamp will go off and the answer lamp will go on. The attendant must go active on that switch loop and then depress release to give up control of the call.

##### *Attendant Releases Call*

The attendant splits away from the original caller and dials the appropriate "Meet-Me" pager number. The attendant, upon hearing ringing tone, immediately hits the release key. The call is not dropped from the attendant console but the attendant is free to answer other calls. The loop is tied up until the call is answered, at which time the loop is automatically freed. The attendant may get back on the call any time before it is answered by depressing the loop key. The call will go to coverage when the coverage criteria have been met. This is always true except when the "Meet-Me" Pager number does not have coverage and ARL is active and the caller is external.

### *3-Party Conference Scenarios for "Meet-Me" Paging*

#### *Single Line Stations*

In a single line station environment, if an established 2-way conversation wishes to add a third party who only has a "Meet-Me" pager number: A station in the existing call flashes, with the switch hook or the recall button depending on the set being used, and dials the appropriate "Meet-Me" pager number. The system will automatically send a message over an RS-232C port to a Motorola Tone Pager unit. The Motorola transmitter will send a tone alert to the appropriate pager. If the caller flashes again while ring back is heard the call to the "Meet-Me" pager will be canceled and the two original callers will be re-connected.

If the owner of the pager number retrieves the call before the specified time period. The tone is heard and the 2-way connection is established and the pager line number is available for additional calls. The originating station may now flash again to establish a 3-way conference.

If the owner does not retrieve the page before the specified time period: The call will be diverted to the backup coverage position. Once the coverage position answers the call it is considered a 3-party call even though one party is on soft hold. If the owner of the pager number attempts to barge-in they will receive busy tone.

#### *Multi Line/Function Stations*

If digital sets with multiple call appearances are being used by the established 2-way conversation, then a different scenario is possible. If one of the existing stations depresses the conference button, the other party will be put on hold on the first line and a second line appearance will be seized. The user may then dial the appropriate "Meet-Me" pager number. The system will automatically send a message over an RS-232C port to a Motorola Tone Pager unit. If the user depresses the conference button for a second time, then the 2 original parties are connected on the first line and both hear ringing and the call proceeds as a normal page except for the fact that if the call is answered by a backup coverage position a 3-way conference is established. If, on the other hand, the caller does not depress the conference button for a second time then the following is possible.

The owner of the pager number retrieves the call before the specified time period. The tone is heard and a 2-way connection is established. The conference button may now be depressed to form a 3-way conference call. The pager line number is available for additional calls.

If the owner does not retrieve the page before the specified time period, the call will be diverted to the backup coverage position. If the coverage position answers and the conference button is depressed a 3-party will now be established. If the coverage position answers and the owner barges-in before the second push of the conference button, then there will be a 3-party conversation on the second line, while the original party is still on hold on the first line. A second depression of the conference button at this point will be ignored.

In any case where a 3-party call is existing, (that is, 3 parties talking or 2 parties talking with one on soft hold) and a barge-in is attempted, the barge-in party will receive busy tone.

If, during any of the previously described scenarios, the pager number is deemed unavailable, the caller will receive a busy tone. If the owner of a pager number attempts to retrieve a page and there is no caller on the page line or at the back up coverage position, or there is an auxiliary circuit involved on the call, busy tone will be returned.

In general the page number is considered unavailable when:

1. The pager number is ringing.
2. A backup coverage position has answered and is active on the call.

#### *RS-232C Message Handling*

The appropriate message necessary to transmit the paging tone will be automatically generated by the System 85®. The message will be based on the line number assigned as a pager number. If a positive response is not received from the Motorola Paging equipment the message will be re-sent.

All messages will be sent with four digit numbers to the Motorola Paging equipment.

Messages will be sent at a rate of at least five (5) per second at 1200 BAUD. Faster transmission rates will be possible at higher BAUD rates. This rate is limited by the speed at which the Motorola Paging equipment can process each message.

The RS-232C interface of the System 85® has the capability of determining it's own health. If a problem is detected, there is the option for switching to another circuit if one is provided. The number of re-sent messages within a given time-frame will be one of the criteria used to determine the health of the circuit.

#### *Meet-Me Paging with Manual Paging*

The above scenarios for Meet-Me Paging assume the use of the PCC RS232 interface board in the System 85® and Motorola Tone Paging equipment to implement automatic paging. Alternatively, the pager numbers can be assigned to have all of the Meet-Me Page capability but not send messages over the RS232 circuit. Either loud speaker or radio paging may be used to notify the paged party to pick up the call.

#### *Manual Paging Scenarios*

##### *Transfer to a Meet-Me Page Number Using Multi Line/Function Stations*

A multi-line station involved in a two-way conversation may transfer the other party to a third party with a "Meet-Me" pager number. If the transfer button on one of the stations is depressed, the other party will be put on hold on the first line and a second line appearance will be seized. The user may then dial the appropriate "Meet-Me" pager number and, after hearing ring back, may transfer the call on the first line appearance by depressing the transfer button again. The user should then depress a call appearance button and place the page (using either loud-speaker paging or radio paging).

If the paged party retrieves the call before the specified time period, the tone is heard and the 2-way connection is established. The page line number is now available for additional calls.

If the paged party does not answer the page in the specified time period, the call will be diverted to the backup coverage position. Once the coverage position has answered and is active on the call, the paged party will be allowed to barge in to the call.

#### *Conference with a Meet-Me Page Number Using Multi Line/Function Stations*

If parties on an existing 2-way conversation wish to conference in a party with a "Meet-Me" pager number the scenario is slightly different. One of the parties must have a multi-line set. That party depresses the conference button, putting the other party on soft hold and dials the "Meet-Me" pager number. The user may then depress the conference button again, to establish the conference. Both callers will then hear ring back from the pager line. The caller who established the conference should then place the call on hold by depressing the Hold button, select another call appearance and place the page using standard loud-speaker or radio paging. After placing the page, the user should return to the original call appearance and wait for the page to be answered.

If the paged party retrieves the call before the specified time period, the tone is heard and the 3-way connection is established. The page line number is now available for additional calls.

If the paged party does not answer the page in the specified time period, the call will be diverted to the backup coverage position. Once the coverage position has answered the paged party will not be allowed to barge in to the call. However, the coverage position may place the caller on hold, at which time the paged party will be allowed to pick up the call. When the paged party has retrieved a call that was placed on hold by a coverage position, the coverage position will be dropped from the call.

#### *Transfer to "Meet-Me" Page Line by the Attendant*

If a caller connected to the attendant console wishes to speak with a party having a "Meet-Me" page number, the following scenario is possible. The attendant splits away from the original caller and dials the appropriate "Meet-Me" pager number. The attendant, upon hearing ringing tone, immediately hits the release key. The call is not dropped from the attendant console but the attendant is free to make or answer other calls. The attendant should use a free loop to page the called party using standard loud-speaker or radio paging. At this time the caller hears ringing tone. At any time before the paged party answers the call, the attendant may get back on the call by depressing the loop key. After the call has been answered, the loop will be freed.

If the paged party does not retrieve the call in the specified time, the call will go to the coverage position. After the coverage position has answered the call the attendant loop is removed from the call if the attendant has not depressed the loop key. The paged party may barge in to the call at this time. If the paged party has not answered the page, the coverage position may place the call on hold if the caller wishes to wait an additional amount of time. If the paged party retrieves the page while it is on hold at the coverage position, the coverage position will be dropped from the call.

#### *Attendant Remains on Call*

The Attendant may remain in control of the call by use of the hold key. The attendant depresses the split key and dials the appropriate "Meet-Me" pager number. The attendant then depresses the hold key, putting the switch loop on hold and connecting the original caller to ring back. The attendant then depresses another loop key and makes a loud-speaker or radio page. If the paged party does not pick up the call in the specified time, the ring lamp for the switch loop on hold will begin to flash. To return to the call the attendant need only depress the associated switch loop key. If the call is answered by either the page owner or the coverage point the ring lamp will go off and the answer lamp will go on. The attendant must go active on that switch loop and then depress release to give up control of the call. If the call has been answered by the coverage point, the paged party may not barge



in. The coverage point will not be allowed to place the call on hold.

### **Malicious Call Trace**

This feature allows a station user or console operator to activate a Malicious Call Trace on a call in order to obtain more information about the source of the call. Activation of this feature will cause information concerning the calling and called parties to be stored in memory for display at a console, the attendant consoles to be alert, and a recorder to be connected on 2-way calls to record the actual call.

#### *Activating Malicious Call Trace*

The Malicious Call Trace feature may be activated by a station user or a console operator. An attendant may activate the feature by depressing the malicious call trace activate key while active on the switched loop with the malicious call. The user of a multi-button station may activate malicious call trace by depressing the malicious call trace key while talking on the malicious call. A no-button station user who receives a malicious call may activate the feature by using a switch-hook flash, dialing the Malicious Call Trace activate code, and using another switch-hook flash to return to the call. A multi-button station user may not dial the dial access code to activate Malicious Call Trace on a call on another appearance on that set.

Another station may activate the Malicious Call Trace by dialing the malicious call trace activate code, hearing dial tone and dialing the extension number of the station receiving the malicious call. This method may be used to activate Malicious Call Trace on another extension with multiple appearances. However, the system may not always select the correct appearance for the Malicious Call Trace. The Malicious Call Trace button push by the person receiving the malicious call while active on the correct appearance is recommended to resolve this situation. A station on a 3-way call must use a button press or have another station activate Malicious Call Trace.

Activation of the feature will cause the following actions to occur:

1. All facilities associated with the call will be locked up except the station or attendant that received the malicious call. This will allow the called party to make other calls if necessary.
2. If a Malicious Call Trace recorder is assigned and the call is a 2-way call, the recorder will be connected and begin recording the call. The recorder will not be connected on a 3-way call.
3. Information about the call will be gathered and placed in memory for display at the attendant console.
4. An alert will be made to all attendant consoles, excluding the activating console if activated by an attendant. This alert consists of a continuous audible signal and flashing of the lamp associated with the malicious call control key. The activating console will be alerted using only the flashing lamp, and will not receive the continuous audible signal.

Only one Malicious Call Trace is allowed to be active in the system at any time. If a user attempts to activate Malicious Call Trace while another trace is active the attempt will be denied. If the attempt is made by an attendant button push, the button push will be ignored. If the attempt is made by a button push on a multi-button set, the button push will be ignored. If the attempt is made by dialing the Malicious Call Trace activate dial access code, the user will receive busy tone. If the attempt was denied, the user should keep trying to activate the feature every few minutes as long as the malicious caller has not disconnected.

Malicious Call Trace can only be activated from a talk state. Intercept tone will be given to a station that dials the Malicious Call Trace activate code and attempts to activate the feature on a

station in an invalid state. A Malicious Call Trace button push on a multi-button set or attendant console will be ignored if the extension or switched loop is not in a valid talk state.

Parties talking to an attendant will not be allowed to activate Malicious Call Trace. If Malicious Call Trace is to be activated in this case, it must be done by the attendant. If the attendant puts two talking parties on hold, one of the parties could activate Malicious Call Trace by pressing the Malicious Call Trace activate button. In this case, the Malicious Call Trace display will show the attendant as the called and activating parties and the other two parties will appear as the calling and third parties.

#### *Controlling a Malicious Call Trace*

When the consoles receive the indication that a malicious call exists, one of the attendants should take control of the trace by pressing the malicious call control key. This console will then have control of the trace until the trace is deactivated by dialing the Malicious Call Trace deactivate code. When an attendant takes control of a Malicious Call Trace, the audible signal will stop on the consoles, the called party will be displayed on the console ICI display and that console will be placed in position busy mode. This attendant may then step through the Malicious Call Trace information by pressing the malicious call control key again for each item of information. The call information will be displayed in the following form:

1. Called extension or attendant number.
2. "LINE" or "TRNK" This indicates the type of facility of the calling party.
3. If entry #2 indicates a line, then the calling party's extension number will be displayed. If entry #2 indicates a trunk as the calling party, the incoming trunk's port equipment number will be displayed in three ICI display groups as follows:
  - A. Module/Frame
  - B. Carrier
  - C. Slot/Circuit

Calls using remote access trunks will indicate a line with a blank line extension number.

4. "ACTV" OR "IDLE" This indicates whether or not the called party is still connected to the malicious call.
5. If a third party is not on the call, the display will skip forward to the activating extension number. If a third party is on the call, the display will be "F3LN" OR "F3TK" to indicate the third party is a line or trunk.
6. Third party extension number or trunk information as described in three (3) above.
7. Activating extension number or activating attendant. This is the extension number of the line used to activate the Malicious Call Trace or the activating attendant number.
8. "END" This indicates the attendant has reached the end of the call information. Another push of the Malicious Call Trace control key will restart the display at the called party above. The call information may be displayed as many times as necessary until the attendant deactivates the Malicious Call Trace.

If the malicious call came in on a trunk as indicated by display items 2 or 5, the attendant should notify the central office (or distant PBX in the case of a tie trunk) immediately to give them the identification number for the trunk. This will allow them to carry the trace further from their end. A conversion chart should be available to the attendant to convert the trunk port equipment numbers into their identification numbers. The central office or distant PBX needs the identification

numbers to trace the call further.

An attendant who has activated Malicious Call Trace can put the malicious call on hold and originate calls by selecting an idle switch loop. This is important if the activating attendant also controls the Malicious Call Trace. In this case the attendant can push the hold key, select an idle loop and call the central office or distant PBX to relay the Malicious Call Trace information as needed.

#### *Deactivating Malicious Call Trace*

When it is determined that a trace has been completed, the controlling attendant may deactivate the trace by selecting an idle loop, pressing start, and dialing the Malicious Call Trace deactivate code. This will cause all facilities on the call to be disconnected, the flashing malicious call control lamp to be turned off, the recorder to be made idle, and the display memory to be cleared. The controlling attendant and activating attendant if appropriate will be released from the position busy mode, even if they had been in position busy prior to controlling or activating the malicious call trace.

#### **Attendant Direct**

The purpose of this feature is to allow calls over specific incoming trunk groups to be answered on user-defined groups of attendant consoles and to allow station to attendant calls to be assigned in the same manner to a specific attendant group. Calls which are forwarded to the attendant are also attendant directed to the station's pre-assigned attendant group. Also, calls which normally receive attendant intercept treatment are directed to a pre-defined attendant group for intercept. An attendant group consists of one or more consoles as defined by the customer. An attendant console may only be a member of one attendant group. A call may be assigned to not be directed, in this case the call will go to the first available attendant regardless of the attendant's group assignment.

#### *Listed Directory Number and Trunk Calls*

All Listed Directory Number (LDN) calls and all incoming calls on non-DID trunks will be directed to a customer defined attendant group (up to a maximum of 15 groups). If an attendant group cannot be determined for the LDN, then the call will be treated as an undirected call. That is, it will go to any available attendant. This feature allows up to 9 LDN's and 9 dedicated ICI messages to be used for the LDN's.

#### **Dial Zero and Attendant Emergency Alert Calls**

All station dial '0' calls will be directed to an attendant group. The assignment of dial '0' to attendant group will be based on that station's Line Class-of-Service. Emergency calls to the attendant will be routed by Attendant Direct the same way a dial '0' call is - the emergency call will go to the same attendant group that it would have if the station had dialed '0'.

#### *Call Forwarding to the Attendant*

When call forwarding to an attendant occurs, a station call will be forwarded to the attendant group associated with the station which has call forwarding invoked. In the case of a trunk call to a forwarded station, the call will route to the trunk group's attendant group. This routing will occur for all types of call forwarding; all, busy and don't answer.

If an attendant extends a call to a station which is forwarded to the attendant, the call will be forwarded if the attendant is not in the same group as the station called; otherwise the attendant will hear busy tone.

Intercept is returned to an attendant that tries to call or extend a call to a ACD group whose associated extension is forwarded to an attendant.

#### *Timed Recall to the Attendant*

When timed recall on an outgoing trunk occurs, the call will be routed to the calling station's attendant group.

#### *Attendant Release Loop*

A call being recalled to the attendant using ARL will return to the attendant group associated with the incoming trunk group unless the call came in via an LDN. In this case, the call will recall based on the LDN. ARL calls may not return to the same console but will return to the same group. If a trunk call comes into an attendant, is forwarded to a station and the station does not answer, the call will be returned to an attendant in the trunk's attendant group.

#### *Attendant Intercept Treatment*

When intercept treatment is defined to route a call to an attendant, the system will route the call to the proper attendant group. When an invalid DID number is dialed by a trunk, the call will be sent to the attendant group assigned to the trunk group. If a valid station number is DID restricted, the intercept treatment will route the call to an attendant group based on the stations Line Class-of-Service.

#### *Attendant Direct Overflow*

If all the attendants in the attendant group are busy on other calls when another call for the attendant group is received, either the call waiting lamp(s) on the consoles in the attendant group will be lit or 'overflow' conditions (described below) will be evaluated. The customer may choose to have calls to one attendant group directed to another attendant group called an overflow group. In such a case, calls will be directed to the overflow attendant group depending on the status of the consoles in the primary attendant group.

The customer can choose one of the following conditions to trigger overflow:

1. Each console in the attendant group has had its headset removed or has had its POSITION BUSY key activated.
2. Each console in the attendant group satisfies the first condition described above or has all six of its switch loops in use to process calls.

The call will then be directed to the attendant group which is customer defined to handle calls when the primary group is unavailable. This overflow attendant group consists of one or more attendant consoles. The overflow group can also overflow if it in turn satisfies its own customer chosen overflow conditions. The standard method to insure proper processing of attendant overflow calls after a power failure is accomplished by unplugging the headset from all consoles in an attendant group rather than using the POS BSY key.

The Attendant Direct feature only allows overflow chains of length two, that is, group A can overflow to group B which can overflow to group C, but C cannot overflow. The feature also prevents the sort of looping that would occur if group A overflowed to B and group B overflowed to A.

#### *Attendant Call Waiting and Priority Lamps*

If a call is directed to an attendant group and placed in the attendant queue, the call waiting lamp

on all the consoles in that particular attendant group will be lit. If a call overflows, the call waiting lamp on the overflow console(s) will light if the overflow group is not in night service and not in an overflow condition. If the overflow group is in night service the call waiting lamp will be lit on the console to which the call was originally directed. If the console to which the call was directed has the headset removed, there will be no indication of a call waiting.

The priority lamp will remain lit on the primary attendant group consoles unless the call has overflowed and a console in the overflow group is idle, in which case the priority lamp on the overflow console will be lit.

The capability to flash the call waiting lamp at a pre-determined threshold of calls waiting has not been modified. There is an independent call waiting peg count for each attendant group. The call waiting lamp for a certain attendant group will not flash until that attendant group's call waiting peg count has reached the system wide threshold limit. The number of calls waiting is determined separately for each attendant group.

#### *Call Transfer*

A station can place a call on soft hold and, by dialing the attendant, transfer the call to its own attendant group.

#### *Six Way Attendant Conference*

When a station that is in an established 6-way attendant conference flashes to recall the attendant, if no attendant has control of the conference (i.e., has that conference on a switch loop), then that call is directed to the attendant group of that station Line Class-of-Service.

#### **Split Night Service w/Attendant Direct**

This feature allows each attendant group to be put in night service on an individual basis. From a user standpoint the operation will appear to be the same as the standard feature. The last attendant in a group to leave the site, depresses the NITE key and all calls directed to the group of which that attendant is a member will be directed to a dedicated night station. Each group may be assigned their own common and default stations. The lamp for the NITE key will flash at all consoles whose group is in the night mode, all other consoles' night lamps will not be affected. The full night service will not change from its present use, but the attendant may only change the night station for trunk groups which are directed to their attendant group.

#### **Attendant Two-Way Splitting**

A new console control key will be available to allow for splitting away either party when the attendant has two other parties on the loop. The attendant will now have two split keys, a "SPLIT CALLED" party and a "SPLIT CALLING" party. The attendant will now have the ability to flip-flop between the called and the calling party. To connect both parties the attendant will have to depress the same split key twice in a row.

#### **Attendant Emergency Alert with Immediate Talk Path**

The Attendant Emergency Alert feature allows a station user to access the attendant in an emergency situation. The alert can be activated either by a dial access code or by going off-hook and timing out. The dial access code can be defined to be either 1, 2 or 3 digits. There will be a maximum of 10 unique dial access codes which may be assigned to different ICI messages. There may also be a special ICI message assigned for the time-out case. This will allow for a distinction between different types of emergencies.

If a calling party enters an emergency situation, an audible signal is given to each attendant in the attendant group associated with the originating party and the priority queue lamp begins flashing. If there is a console in a state to receive the emergency call (i.e., there is an idle switch loop), then only that console will remain in a ringing state and the appropriate ICI message will be displayed. When the attendant depresses the ANSWER button, the audible signal will be removed and an immediate talk path will be established with the emergency party. To identify the calling party's directory number, the attendant can press the Class-of-Service control key. If the attendant has answered an emergency call, the emergency station is locked into the console until the attendant releases the call. The attendant may identify the calling party's directory number any time before releasing. Up until this point, the station cannot dial again until the attendant releases, even if the station has hung up. If the calling party hangs up before the attendant has answered the emergency call, the call and the alerting tone are cleared from the console and/or the queue.

#### *Attendant Emergency Alert Timeout*

In the timeout case the assigned timeout ICI message is displayed on the first available attendant console in the attendant group associated with this station. In the case of the emergency dial access code the associated ICI message is displayed. If there are no available attendants, the first attendant to become idle (by depressing release, hold, etc.) will get the emergency call. If there are multiple emergencies, the audible and lamp signals continue. There is no limit to the number of emergency calls coming to the attendants.

The customer selects the line COS's which are to have the Attendant Emergency Alert feature.

#### *Attendant Emergency Alert Dial Access Code*

Access to the DAC may be allowed on a system wide basis, in which case stations and trunks may use the emergency alert dial access codes. A Line Class-of-Service may be assigned to have access to the DAC and have time-out access to the feature regardless of the system wide assignment. Calls are directed to associated attendant groups as described in "Attendant Direct".

#### *Attendant Emergency Alert and DCS*

The feature, Attendant Emergency Alert with Immediate Talk Path, will be adapted to a DCS environment. A station calling from a DCS node with no attendants that is in the emergency situation (has dialed a emergency access code) will be routed across a main/satellite trunk to the main. Timeout access to this feature from a DCS node is not allowed. When the emergency call reaches the main, the audible signal will be heard at all attendant consoles in the appropriate attendant group and the call will be attendant directed at the main based on the incoming trunk group, not on the station Class-of-Service. The attendant can then use the COS button to identify the calling party. If, at any time, the emergency call hangs up, the emergency call and the alerting tone will be cleared from the console and/or the queue. If the emergency call hangs up before the attendant hits RELEASE, the call is cleared from the queue but the ICI field will display the caller's COS and station ID until the attendant hits RELEASE. This is only true for calls coming from a DCS node and is different than calls on the main. (See the above description for details.) If a tie trunk comes into a DCS node and dials the emergency alert access code, it will be routed across to the main as an emergency call. In this case the COS key is not operational since there is no station involved.

#### **Emergency Access of Trunks by Attendant**

This feature will assure the attendant of the ability to seize an outgoing trunk in an emergency situation. To activate the feature the attendant must:

1. Select a switch loop, unless already active on a switch loop.
2. Depress the special emergency access control key.
3. Dial the outgoing call in a normal fashion, using the START, SPLIT or group select keys as appropriate.

If there is an idle trunk in the trunk group then that trunk will be seized as is normally done without this feature. If all the trunks in the chosen group are busy the attendant will not receive busy tone and will not be queued. Instead the following will occur:

1. At random, one of the busy trunks will be chosen for preemption. A previously preempted trunk still active on an emergency call will not be eligible for preemption.
2. The parties currently using the trunk will be given a 2 second warning tone.
3. Following a 10 second delay the parties will be dropped from the trunk and the attendant will be given control.
4. The attendant will receive dial tone and may begin dialing the emergency call.

The Emergency Access of Trunks by Attendant feature will only be active when the associated control key is depressed. At all other times attendant dialing is handled in the normal fashion. If the attendant wants to make an emergency call for a third party, the attendant merely depresses the special emergency access control key before depressing the start or split key in order to place the call. This feature will only preempt for CO, FX and WATS trunks (trunk types 17, 19, 22, 24 and 27) through direct trunk access or ARS access. Trunks involved in a previously preempted call or a 6 or 4 party conference are not eligible for preemption. An attendant on a trunk call will not be pre-empted. Only trunk calls that are in a ringing state or a stable talk state will be eligible for pre-emption. A trunk which is involved in a 3-party call may be preempted but the other 2 parties will be able to continue their conversation.

#### **Attendant Service Observation**

This feature will provide the ability to designate an attendant console to be a supervisory position. To activate the feature the attendant must:

1. Dial the supervisory Dial Access Code.
  - a. If the console is already being monitored by another console, intercept is heard.
2. Dial the console number to be monitored.
  - a. If there is another console monitoring the console or the console is supervising another console, or the console is the same as the supervisor or the console is in another module, intercept is heard.
  - b. Otherwise the attendant is now supervising the specified console.

While a console is in a supervisory mode the regular and priority call queue waiting lamps will be activated based upon that console's calls, not the calls to the console which is being monitored.

Upon feature activation, the following will be updated immediately on the supervisory console, based upon the status of the monitored console:

- Position Busy key lamp
- Position Available key lamp
- ICI display

- Loop lamps

Thereafter, the following monitored console status will be updated on both the supervisory console and the monitored console:

- Position Busy key lamp
- Position Available key lamp
- ICI display
- Loop status
- Trunk group busy
- All control keys
- DXS lamps - Does not apply in 5-Digit Dialing environment
- Busy lamp field - Does not apply in 5-Digit Dialing environment

All ringing tones will be abbreviated on the supervisory console. The supervisory console will still receive the following tones:

- Emergency Alert Tone
- ACA call
- Timed Reminder tone
- Call waiting 'click' tone

This feature does not allow silent observation of the monitored console. The supervisory console user may use the headset with muting feature for this capability instead of the handset.

All button pushes except the RELEASE key are ignored while a console is in a supervisory mode.

To deactivate this feature:

1. Press the RELEASE key.
2. Supervisory console is taken off the talk path.
3. POSITION BUSY lamp is updated.
4. The feature may be re-activated by any console via the supervisory DAC.

When using Attendant Service Observation with ETN, DCS and CAS, both consoles (supervisory and supervised) must be on the same node.

#### **Automatic Termination Restriction by Time of Day**

This feature allows for stations to have the termination restriction activated and deactivated based on Class-of-Service. There will be a time range (e.g. 21:00 to 06:00) during which designated Classes-of-Service will be termination restricted. At all other times of day the pre-assigned controlled restrictions for a station will apply. The start and stop times for the Automatic Termination Restriction are set on a system wide basis. Classes-of-Service may be assigned to use or ignore this automatic restriction change. There will be a new intercept treatment type for this feature so that it is possible to use a special recorded announcement when the Automatic Restriction is active. The attendant may still modify controlled restrictions on a per group or per station basis at any time. This can be used to override the Automatic Termination Restriction. It will take approximately 10 minutes for all of the lines to be restricted. So if the start time were 21:00, it could be 21:10 when all of the lines have been checked and the feature activated as



appropriate. The same is true for the stop time to deactivate the feature for all of the lines.

### **Time-of-Day and Calls in Queue Display**

Two new console control key types will be added to the system. The first key will be for a time-of-day clock. When the 'clock' key is depressed the current time-of-day will be displayed in military time in the 4 character ICI field, (no colon will appear between the hour and minute digits). The second key will be for displaying the number of calls in queue. When this key is depressed the current incoming call queue length for the attendant group of which the activating console is a member will be displayed in the ICI field. Note that a call to an attendant may either be directed to a specific attendant group or "undirected." An undirected call may be answered by any attendant in the system, independent of the attendant group. The number of calls in queue for a given attendant will be the number of calls waiting for the attendant group to which that attendant belongs plus the number of undirected calls waiting in the system, plus the number of emergency calls waiting in the priority queue for that attendant group, plus any undirected emergency calls. These displays will remain until new incoming call arrives or another button is depressed which affects the ICI display field.

### **HARDWARE REQUIREMENTS**

This feature package is designed to operate on the System 85®, R2V3 PBX.

The following special hardware is required for "Meet-Me" Paging with 4-Way Conferencing.

- Motorola Tone Pager

Motorola Tone Paging equipment with a Quad-Alpha board is required for "Meet-Me" Paging.

- TN474 Processor Communications Circuit (PCC)

The RS-232C interface for the System 85® TN474 circuit pack is required for the transmission of messages to the Motorola paging equipment. It is necessary to have one of these per System 85® processor.

- SN232 Auxiliary Trunk Circuit

Four-party connections require SN231 Auxiliary Trunk Circuits. Circuits 0 and 1 and circuits 2 and 3 must be hard wired together. Additionally, the option switches should be set for voice transmission in both directions.

The following special hardware is required for Malicious Call Trace.

- Voice Recorder

This is CPE (Customer Provided Equipment) used to record malicious calls. The recorder selected must be suitable for remotely controlled operations. It should have an automatic gain control or have a recording level adjustment that can be set to an appropriate level.

- SN231 Auxiliary Trunk Circuit

An auxiliary trunk circuit on an SN231 circuit pack is required for each voice recorder (four circuits per SN231). An auxiliary trunk circuit provides provides the switchable talking path between the malicious call and the recorder. When MCT is activated, the SN231 passes audio signals and on/off control to the recorder via the 278A interface.

Each trunk port on this circuit pack used for this feature should be optioned (assigned) as a 1-way outgoing and 4-wire signaling trunk.

- 278A Adapter

One 278A Adapter is needed for each voice recorder. This unit is recommended because it provides isolation between SN231 trunk equipment and the recorder. Without the 278A, there is no protection on the Audio Path from power surges.

The 278A has two options and both can protect the audio path on the trunk circuit. The C1/C2 option is the recommended option because it has 17 ohms of resistance in series with its relay contacts that provide current-limiting protection to the trunk circuit. If the recorder is unable to work with this resistance (impedance) to the microphone input of the recorder, use the following option. The BY1/BY2 option does not have current-limiting protection but has approximately zero ohms of resistance (impedance) to the microphone input.

The 278A can be mounted in the Auxiliary Cabinet or wall mounted next to the cross-connect fields.

- Power

A D-181321 power kit is required for each 278A control unit. This unit converts -48 V dc to -24 V dc power. If the 278A is installed in the Auxiliary Cabinet, use cabinet power. In either case, the ground lead which goes to the 278A should eventually be attached to the single-point ground in the equipment room.

## SOFTWARE ENVIRONMENT

Feature Package PG-3W024 is based upon the existing features contained in System 85®, R2V3. It is run tape compatible with standard System 85®, R2V3 Issue 1.X.

All features not dealing with the pager line numbers or RS-232C interface or the other Attendant features described in this document will operate as described in standard AT&T Documentation.

## INTERACTIONS

### "Meet-Me" Paging

#### *Automatic Callback*

If one attempts to call a Page Line and the Page Line is busy and the COS for the Page Line permits Automatic Callback, the caller can request callback and will receive confirmation tone, but the callback will never happen.

#### *Call Coverage*

Multiple coverage points may be assigned for a pager number. The system allows for up to three coverage points. If any point in the coverage path is unavailable, the call will be directed to the next point in the coverage path. While a call is searching the coverage path it may be retrieved by the owner of the pager number. During this time the pager number is unavailable for additional calls. The coverage points may be line extensions and the last point may be a ACD group.

If the last coverage point is a ACD group for a pager number then the caller enters the queue for the group and the page line is freed. That is once the call enters the queue the owner of the pager number will not be able to pickup the call. The pager number will be available for additional calls.

#### *Call Forwarding*

A pager line number may use the Call Forward All feature, but not Call Forward Busy/Don't Answer. Call Forwarding All may be established and canceled only through the attendant console.

#### *Remote Access*

The remote access trunk group used to answer page calls will be subject to the same system wide assignments as all other remote access trunk groups. Assignments of barrier codes and shared status will apply to all remote access trunk groups. This means all remote access must be assigned as not shared with LDN to have the ability to retrieve a page call at any time. It is required that all remote access trunks be accessed by Touch Tone Telephones.

#### *DID Restrictions*

Pager line numbers will have the ability to restrict incoming DID calls by class of service. This is done in the same manner as is done for regular lines.

#### **Malicious Call Trace**

##### *Attendant Auto-Manual Splitting*

If an attendant activates Malicious Call Trace while a calling or called party is split from the console, the split condition is disabled. On the attendant console, the split lamp goes out. For the previously split party, the split returns dial tone to an internal caller or disconnects an outside caller from the switch.

##### *Attendant Interposition Calling and Transfer*

If an attendant selectively calls the activating or the controlling attendant during an active Malicious Call Trace, the switch returns ringback to the calling attendant. However, the called attendant will only receive ringing if the attendant has unbusied the console.

For the controlling attendant, priority lamp activity is provided for interposition calls during a trace. However, the controlling attendant does not receive an ICI display for these calls. Instead, the alphanumeric display is reserved for displaying trace information.

For the activating attendant to receive an interposition call, the malicious caller must be placed on hold, and the console must be unbusied. Then, an interposition call will cause the loop lamp to flash and the priority lamp to go out.

##### *ACD (Automatic Call Distribution)*

If an ACD agent receives a malicious call, the Malicious Call Trace feature can be activated by the ACD agent. It is preferable, when malicious calls are more than a rare occurrence, to assign the EMERGENCY button to every agent's multiappearance voice terminal.

If an ACD agent receives a malicious call and activates the Malicious Call Trace feature while the agent is being observed using service observing (as opposed to Agent Override), the observer may continue to monitor the malicious call and subsequent calls normally. Furthermore, service observing allows the observer to *begin observation* after Malicious Call Trace has been activated.

##### *Busy Verify*

An attendant who receives a call from another PBX indicating the source of a malicious call is a trunk on this PBX may activate Malicious Call Trace on that trunk to obtain more information about the call. This is accomplished by doing a busy verify on the trunk and then pressing the

Malicious Call Trace activate button on the console. It should be noted that a warning tone will be given when the attendant busy verifies the trunk and the recorder will not be added at this PBX since the call is a 3-way call. The Malicious Call Trace would then be handled the same as any other trace.

*City/Queue-of-Origin Announcement:*

An ACD agent cannot activate Malicious Call Trace during a city-of-origin or a queue-of-origin announcement. When this 2-second announcement finishes, the trace can be activated.

*Agent Override:*

If an Agent Override call is attempted toward a line involved in Malicious Call Trace, the caller attempting to do the override receives intercept tone.

*Call Waiting*

Calls are not allowed to wait on a line involved in a Malicious Call Trace. Instead, the calling party receives busy tone.

*Conference - Three Party*

When Malicious Call Trace is activated during a 3-party conference, the malicious caller's identity in the trace information becomes uncertain. The contents of Items 2 and 5 and of Items 3 and 6 in the controlling attendant's display can be reversed.

If there is one (and only one) party in the 3-party conference who is connected to the switch over an incoming trunk, the MCT software presumes that this party is the malicious caller. This party is identified as the malicious caller in Items 2 and 3 of the controlling attendant's display.

Sometimes, this ambiguity can be avoided with human intervention. Since the malicious caller usually initiates a malicious call, the originally called party can press the DROP button to disconnect the third party in the conference, verify that the malicious caller is still on the connection, and then quickly activate the trace. However, when this is done, the third party cannot be re-added to the conference.

*Multi-Appearance Sets*

On a multi-button set with the line appearance which activated Malicious Call Trace and a Malicious Call Trace button, the Malicious Call Trace lamp will be lit whenever the line appearance is selected and the trace is still active.

*Music-on-Hold Access*

When Malicious Call Trace is activated on a switch that provides Music-on-Hold, the originator of the malicious call receives music whenever this caller is placed on hard hold. This effect usually occurs when Malicious Call Trace is activated from a multi-appearance voice terminal using the dial access code.

If this functionality is considered unacceptable, there are several ways to attenuate or circumvent the problem. To minimize the caller's alarm, the person activating Malicious Call Trace can advise the caller, "I need to put you on hold for a short time. I'll be right back." Other alternatives are to provide MCT ACTIVATE buttons for voice terminals that are likely to receive malicious calls, or to activate Malicious Call Trace from a neighboring voice terminal. If the previous alternatives are considered unacceptable, Music-on-Hold can be disabled using Procedure 275, Word 1.

### *Override*

If an Override call is attempted toward a line involved in a Malicious Call Trace, the calling party receives busy tone.

### *Priority Calling*

If a priority call is attempted toward a line involved in a Malicious Call Trace, the calling party receives busy tone.

### *Soft Hold*

If Malicious Call Trace is activated with a party on soft hold, the soft held party will be dropped. If Music On Hold is active, the music will be removed. The recorder will then be connected to the call.

### *Station Calls to Selected Attendant*

Station to selected attendant calls to the activating attendant will receive busy tone. Calls to the controlling attendant will receive busy tone if the controlling attendant is in position busy mode. If the controlling attendant is not in the position busy mode the call will complete normally.

### *Timed Recall on Outgoing Calls*

During a malicious call, the Timed Recall feature is deactivated for a trunk that is involved in the malicious call.

The activating console receives modified Timed Recall operation during a Malicious Call Trace. If the activating console is position busy, the Priority lamp lights during a timed recall, but the tone does not sound. If the console is not position busy, the Priority lamp lights and the tone sounds during a timed recall.

The controlling console also receives modified Timed Recall operation during a Malicious Call Trace. While the controlling attendant is performing the trace, the Priority lamp lights during a timed recall, but the tone does not sound. After the trace is deactivated, the Priority lamp lights and the tone sounds for a timed recall.

### *Timed Reminder*

The activating console receives modified Timed Reminder operation during a Malicious Call Trace. While the activating attendant is connected to the malicious call, the Ring lamp flashes during a timed reminder, but the tone does not sound. After the activating attendant disconnects from the malicious call, the Ring lamp flashes and the tone sounds during a timed reminder.

The controlling console also receives modified Timed Reminder operation during a Malicious Call Trace. While the controlling attendant is performing the trace, the Ring lamp flashes during a timed reminder, but the tone does not sound. After the trace is deactivated, the Ring lamp flashes and the tone sounds during a timed reminder.

### *Trunk Verification - Attendant*

The Trunk Verification - Attendant can assist in tracing malicious calls that originate from or tandem through distant switches in the private network. After a attendant at the distant switch is called by the controlling attendant at the local switch, the distant attendant can enter the call using the Trunk Verification - Attendant feature and then activate Malicious Call Trace at the distant end.

**NOTE:** Since the warning tone provided by trunk verification could arouse suspicion by the malicious caller, the verification should be deactivated as quickly as possible.

#### *Unattended Console Service - Alternate Console Position*

While the Alternate Console Position feature is activated, the alternate attendant position (instead of the regular position) is alerted to trace malicious calls. If the alternate attendant responds to an alert first (by pressing the MCT Control button), this attendant can also trace the call.

#### *Unattended Console Service - Call Answer From Any Voice Terminal*

While the CAAVT (Call Answer From Any Voice Terminal) feature is active, the switch does not sound the CAAVT signaling device in response to a malicious call. Instead, the switch will activate a voice recorder and alert the attendant consoles in the normal manner. After an attendant returns to an attendant position, the trace can be performed and the MCT feature can be deactivated.

#### *Unattended Console Service - Preselected Call Routing*

While the Preselected Call Routing feature is active, preselected voice terminals are not alerted to trace malicious calls. Instead, the switch will activate a voice recorder and alert the attendant consoles in the normal manner. After an attendant returns to an attendant position, the trace can be performed and the MCT feature can be deactivated.

**NOTE:** The limitation of only one MCT active in the system still applies.

#### *Visually Impaired Attendant Service*

A visually impaired attendant should not attempt to trace a malicious call. The controlling attendant must be able to see and record the ICI messages. Also, the controlling attendant must be able to read and communicate the information from the cross-reference of trunks.

### **Attendant Direct**

#### *DCS, CAS and ETN*

When Attendant Direct is used in conjunction with DCS, CAS or ETN, for stations not on the main, assignment to attendant group is based on incoming trunk group, not on station Class-of-Service.

#### *Night Service*

The Night Service feature will take precedence over Attendant Direct Overflow. For example, if a console is in Night Service and overflow conditions are satisfied, the call will be directed based on the Night Service feature, not the Attendant Direct Overflow feature.

### **Attendant Emergency Alert**

#### *Abbreviated Dialing*

The emergency alert dial access code may be entered into an abbreviated dial list. Abbreviated dialing can then be used to activate Attendant Emergency Alert.

#### *Attendant Console*

Once emergency signaling begins, two operations of the attendant console are affected. First, any ringing of the console other than emergency ringing is suppressed. Second, the emergency ringing is heard even if "audible off" has been activated.

The emergency audible signal is sent to attendant consoles even if they are in NITE or POSITION BUSY states. The emergency signal is not sent to a console whose headset or handset has been removed.

#### *Attendant Direct*

Attendant Emergency Alert calls are directed to the associated attendant group as described in "Attendant Direct".

#### *Hot Line*

A station that is administered as a hot line station and has the Emergency Alert DAC as the Hot Line destination code can activate Emergency Alert by simply going off-hook. No time-out period is required.

#### *Night Service*

Emergency calls made when Night Service is in effect will be routed to the night station with no special treatment.

Emergency calls that are routed to the night station when the night station is busy and no call waiting is provided will go to the night station and be handled as a normal call.

#### *Remote Access*

The Emergency Alert DAC may be dialed on a remote access call.

A remote access call can time out into the emergency situation if COS 31 is set to permit Emergency Alert timeout (Proc 010) and the Remote Access to Attendant field (Proc 286) is set to 0.

#### *Restrictions - Voice Terminal Restrictions*

A station with total controlled restrictions cannot dial the emergency dial access code. This station can, however, time-out into the emergency situation.

A station with origination restrictions cannot dial the emergency dial access code. This station can, however, time-out into the emergency situation.

#### *DCS*

Attendant Emergency Alert is compatible with CAS or ETN under certain restrictions. Time out access to this feature from a DCS node is not allowed. Stations on the node *must* dial the emergency dial access code. Emergency calls coming from a DCS node that hang-up will be cleared from the console and/or queue regardless of whether the attendant has answered or not. Emergency calls coming from a DCS node will be attendant directed at the main based on the incoming trunk, not on the station Class-of-Service.

If the attendant group, to which an emergency call is directed, is in night mode, then the call will follow the overflow path. If all of the overflow groups are also in night mode, then the call will be directed to the night station of the original attendant group.

The feature, Attendant Emergency Alert with Immediate Talk Path, will be adapted to a DCS environment. A station calling from a DCS node with no attendants that is in the emergency situation (has dialed an emergency access code) will be routed across a main/satellite trunk to the main. Time out access to this feature from a DCS node is not allowed. When the emergency call reaches the main, the audible signal will be heard at all attendant consoles in the appropriate attendant group and the call will be attendant directed at the main based on the incoming trunk group, not on the station Class-of-Service. The attendant can then use the COS button to identify the calling party. If, at any time, the emergency call hangs up, the emergency call and the alerting tone will be cleared from the console and/or the queue. If the emergency call hangs up before the attendant hits RELEASE, the call is cleared from the queue but the ICI field will display the caller's COS and station ID until the attendant hits release. This is only true for calls coming from a DCS node and is different than calls on the main (see above for description). If a tie trunk comes into a DCS node and dials the emergency alert access code, it will be routed across to the main as an emergency call. In this case the COS key is not operational since there is no station involved.

#### *Interposition Calling*

The priority call waiting lamp is used for both interposition calls and for emergency alert calls. Only emergency alert calls cause the continuous audible signals. Emergency alert calls will be answered before interposition calls.

#### **Emergency Access of Trunks by Attendant**

Emergency Access of Trunks precludes the use of AUTOVON. Any attempt to use AUTOVON will result in unpredictable results. The use of AUTOVON will **not** be supported in this feature package.

#### **Automatic Termination Restriction by Time of Day**

All standard restrictions and feature interactions for the standard termination restriction apply. In particular, there are two known (but undocumented) cases where the standard termination restrictions do not operate correctly. Automatic Termination Restriction by Time of Day will operate in the same manner as the standard termination restriction.

1. If an ACD split supervisor is time of day termination restricted and the restriction is in effect, calls to the supervisor's individual extension number continue to terminate at the supervisor's set. This occurs because standard termination restriction is never checked for ACD split supervisors.
2. If a station is time of day termination restricted and the restriction is in effect and the station is a member of a coverage path, calls to that station are not allowed to terminate. However, coverage calls to that station are allowed to terminate. This is the same way that the standard termination restriction feature operates.

#### **Calls in Queue and Time of Day Display**

##### *Attendant Diversion*

If the appropriate button is pressed, Calls in Queue and Time of Day displays will both overwrite the Attendant Diversion display.

#### **RESTRICTIONS**

No modifications have been made to CACS/ECACS, TCM/FM, or CSM. Use of these systems with this special development is not guaranteed or supported. Any procedures that have been modified for this special development are likely to be incompatible with the above systems. No



modifications have been made to TRACS which may affect the availability of CSD's and error listings, also TRACS will not initialize any of the special software translations.

Autovon is not supported in this development. Use of the Autovon feature may produce unexpected results.

### **"Meet-Me" Paging**

The translation of the "Meet-Me" Paging Special Development may only be accomplished using the Maintenance and Administration Panel (MAAP) or the System Management Terminal (SMT). The "Meet-Me" Paging feature will not be translatable using TCM/FM.

The only limitation on the number of pager lines is the total line size of the switch, although this would be unrealistic since the Motorola paging equipment can only handle up to 10,000 numbers. In the System 85® there is a limitation on call coverage groups which will have an impact on the number of pager line numbers which may have coverage.

### **"Meet-Me" Paging with 4-Way Conferencing**

The following is a list of features which may *not* be assigned to pager line numbers:

- DCS - This implies that no page call may be retrieved from any node other than the one from which the page was initiated. Pages may be placed from one node to another but not retrieved.
- Call Waiting - A pager line will either be idle or busy, no caller can be put in a call waiting state.
- Auto Call Back Calling - A station may not activate auto call back calling to a page line number. An attempt to do so will result in confirmation tone applied to the calling party, but the feature will not be activated.
- Busy Verify - The attendant may not verify a pager line. If they try they will receive intercept tone as if an illegal line number was dialed.
- Executive Override - A station attempting an executive override towards a pager line number will receive intercept tone as if an illegal line number was dialed.
- Leave Word Calling - A station may not attempt to apply leave word calling toward a pager line number, any attempt to do so will be ignored.
- ACD Group Members - Pager line numbers may not be assigned as members of a ACD group.
- Send-All-Calls - Pager lines may not use the Send-All-Calls feature. Only the Call Forwarding All feature will be available.
- Call Pickup Groups - Pager line numbers may not be assigned as members of a call pickup group.
- Night Station - A pager line number may not be assigned to receive calls when the system is in night service.
- Attendant Six-Way Conference - If the attendant is calling a "Meet-Me" page line to add them into conference, the attendant will not be able to cancel splitting as is normally the case for other lines.

### *Pager Number Assignments*

The pager numbers must be assigned as special lines with no physical hardware locations. The line number assignments should match those assigned in the Motorola Tone Paging equipment. The line numbers should be unique in the last four digits.

A pager number can be assigned to have all of the "Meet-Me" Page capability but not send a message over the RS-232C circuit. This can be useful for doing localized loudspeaker paging.

The number of 4-way calls in the system at any one time is limited by the number of auxiliary trunks. There can only be one trunk group administered for 4-Way Conferencing and there is a maximum of 256 trunks per trunk group. Since two trunks are required for each 4-way call, there can be a maximum of 128 4-way calls in the system at a time.

#### *Coverage Paths*

If all coverage points are unavailable, a caller to a "Meet-Me" Pager will continue to hear ringing forever.

#### *Coverage Criteria and Intervals*

Call coverage timing is based on two factors, the call coverage criteria and the type of coverage. There are four call coverage criteria: extension active, extension busy, all and don't answer. Each of these criteria may choose what type of call will follow the coverage path. (Extension active and extension busy coverage criteria are not applicable to Page Lines.) The types are no coverage, extension numbers calls only, attendant or trunk calls only or extension, attendant and trunk calls.

Extension active is used if any call appearance of a line number is in use. Extension busy is used if all call appearances of a line number are in use. All means that any call of the type specified will go to coverage. Don't answer is used if the call is not answered within a specified number of ring cycles. For the don't answer case the number of ring cycles may vary from 2 to 6, each ring cycle is approximately 5 seconds. So this means that the don't answer interval may range from 10 to 30 seconds.

The criteria for jumping from one coverage point to the next is as follows: If the extension is busy, i.e. all call appearances of a line are in use, the call immediately skips to the next coverage point. Otherwise, the system wide don't answer interval is used to determine when to switch to the next coverage point.

The suggested use of the criteria for "Meet-Me" pager numbers is no coverage for extension active, extension busy and all, to assure busy tone is returned if the line is busy. The don't answer criteria should be set for extension, attendant and trunk calls with the ring cycles set from 3 to 5.

Call coverage is assigned in groups. Each group has its own criteria, don't answer interval and coverage path. Lines are then assigned to be members of a coverage group. To allow different "Meet-Me" pager line numbers to have different criteria and don't answer time intervals it is only necessary to assign the lines to different call coverage groups. "Meet-Me" pager lines will not function properly for the 'BUSY' criteria, this should not be assigned for groups containing "Meet-Me" page lines.

#### *Call Forwarding*

If call forwarding is active, no page message is generated for the originally called page number. If the forwarded to line is also a page number, the page message will be generated for that page line number.

#### *Tie Trunks*

Tie trunks may not be used to retrieve a page call.

#### *Attendant Console*

Page calls may not be retrieved from an attendant console.

#### *Key Equipment vs. Digital Sets for coverage points*

If the backup coverage positions are to use key equipment, then the system will operate in the following manner. Each "Meet-Me" Pager number will have to be in it's own coverage group. Each of these groups must have unique coverage paths in order to assure availability of coverage which in turn assures availability of the "Meet-Me" Pager line. The coverage point lines will be assigned as normal station lines on the System 85® and any bridging will be handled by the key equipment.

In an electronic telephone environment there are two methods which can be used. To duplicate the operation used with the key equipment assign the call coverage groups individually as with the key equipment. Then assign a coverage point line number per button, maximum number of lines is determined by terminal type, to the electronic sets and use the bridged appearance feature, up to 16, to have more then one answering position.

The second method would be a way to save line numbers in the dialing plan as well as call coverage groups. To accomplish this there would be more then one pager number assigned to a single call coverage group. The coverage positions can then be assigned with multiple call appearances, up to 12, of the same coverage point line number. Each call appearance then may have bridged appearances on other sets, up to 16. In this situation, there will not be a one to one ratio of pager number to coverage number so the coverage points will need electronic displays along with the inspect feature in order to determine for which page number the call was intended.

The system provides a feature known as the names data base. Each extension and trunk group may be assigned a string of up to 30 characters to be displayed. The maximum number of extensions and trunks varies based on the number of characters assigned per extension or trunk. When call coverage is in use, the coverage points will display the entry from the names data base of the originally called party, along with a code for the reason the call has gone to coverage.

#### **Malicious Call Trace**

Only one Malicious Call Trace can be active in the system at one time. Attempts to activate additional Malicious Call Traces using the dial access code will receive busy tone. Attempts made using the Malicious Call Trace button on a multi-appearance terminal or on an attendant console will be ignored.

The Malicious Call Trace recorder will not be connected on three way calls.

On three way calls, the Malicious Call Trace display may not be entirely accurate. Specifically, the calling party information and the third party information may be switched.

The Malicious Call Trace feature should not be controlled by a visually impaired attendant because the trace information will be displayed on the console ICI display.

When the calling party on a Malicious Call Trace is a remote access user, then the Malicious Call Trace display will display a blank for the calling party extension.

This feature is not DCS transparent and operates only on the home switch and does not operate using centralized attendant service.

A Multi-appearance set user cannot activate Malicious Call Trace on one of its appearances by dialing the MCT dial access code from another appearance. In this case, the user must press the Malicious Call Trace button while active on the malicious call. Additionally, Malicious Call Trace

may be activated from another set. However, if the original multi-appearance set has more than one line appearance in use, the wrong one may be selected for the trace. The use of the Malicious Call Trace button is strongly recommended.

If a malicious call trace is activated from an attendant position that has been put into Position Busy, when that attendant deactivates the trace, the console will not be returned to the Position Busy state.

#### **Attendant Direct**

No more than 15 attendant groups can be assigned in the system. Each console may only be a member of one attendant group. If an LDN, incoming trunk group, or Class-of-Service has not been assigned to an attendant group, the call will be directed to any attendant in the system.

#### **Split Night w/Attendant Direct**

Attendants may only change the night service for their own group. The actual line number need not be directed to the group for which it is the night station.

#### **Attendant Emergency Alert with Immediate Talk Path**

It is important to note that the Attendant Emergency Alert feature monitors only situations in which a line times out into the emergency state without dialing any digits or dials the emergency access code. If *any* partial dialing or flashing is done, this feature does not consider the line to be in the emergency situation and does not process that line.

This feature requires at least one console per attendant group to be attended at all times. Should an emergency occur, attendant response at the console is mandatory. If the attendant consoles are not attended, the emergency call will continue to ring without answer. If the console is in night service mode, the call will be directed to the night station. If Attendant Direct Overflow is active, the call will overflow if a console in the overflow group is idle. If there are no idle consoles in the attendant overflow group, the priority lamp on the primary attendant group will flash and emergency tone will be heard. The priority lamp on the Overflow Attendant Group will be lit and no tone will be heard.

In a timeout emergency alert condition, a line enters the priority queue approximately 20 seconds after going off-hook. This 20 second interval consists of approximately 10 seconds of dial tone and approximately 10 seconds of intercept tone. However, if a line is origination restricted, no dial tone is given and only 10 seconds of intercept tone precede permanent signal. In this case only, the line enters the queue and attendant signaling begins approximately 10 seconds after going off-hook.

In the case where the emergency access code is dialed, the alert is immediately entered.

Attendant Emergency Alert calls are directed to the associated attendant group as described in the section on the Attendant Direct feature.

A station with total controlled restrictions cannot dial the emergency dial access code. This station can, however, timeout into the emergency situation.

Attendant Emergency Alert is compatible with CAS and ETN under certain restrictions. Timeout access to this feature from a DCS node is not allowed. Stations on the node must dial the emergency dial access code. Emergency calls coming from a DCS node that hang-up will be cleared from the console and/or queue regardless of whether the attendant has answered or not. Emergency calls coming from a DCS node will be attendant directed at the main based on the incoming trunk, not on the station Class-of-Service.

### **Emergency Access of Trunks by Attendant**

This feature will only preempt for CO, FX and WATS trunks (trunk types 17, 19, 22, 24 and 27) through direct trunk access or ARS access. Trunks involved in a previously preempted call or a 6 or 4 party conference are not eligible for preemption. A trunk which is involved in a 3-party call may be preempted but the other 2 parties will be able to continue their conversation.

### **Attendant Service Observation**

The monitored console may not be supervising another console at any time. Both consoles, the supervisory and supervised, must reside on the same node. The supervisory and supervised console must also reside in the same module. This is a very important restriction since the system will not allow connections of parties residing on four (4) distinct modules.

### **Automatic Termination Restriction by Time of Day**

The start and stop times for the Automatic Restriction may only be assigned on a system wide basis. All Classes-of-Service with this feature active will use the same start and stop times.

If a Class-of-Service is changed to permit or not permit time of day restriction, this change will not be effective for the stations in that Class-of-Service until the next time the start or stop times are passed. For example, suppose the restriction start and stop times are administered to be 2100 and 0700 respectively and Class-of-Service 01 is administered to be time of day restricted and the current system time is 0600. If Class-of-Service 01 is changed to not be time of day restricted, the stations in that Class-of-Service will continue to be restricted until 0700 that morning. They will not be restricted at 2100 that evening. If immediate restriction of a station is required, the feature Restriction - Attendant Control of Voice Terminals may be used.

### **Time of Day and Calls in Queue Display**

The Calls in Queue and Time of Day displays are static. That is, once they are displayed on the attendant console, they will not be automatically updated if the time of day or number of calls in queue change. They may be updated by pressing the appropriate attendant key again.

Since the attendant display is only 4 characters long, the maximum number of calls in queue that can be displayed is 9999. If there are more calls in queue, the 4 characters "OFLW" will be displayed.

Attendant Interposition Calls and Station Calls to Selected Attendant will not be counted in the calls in queue.

## **INTERFACE**

### *Motorola Pager Protocol*

This peripheral device uses a terminal oriented protocol. The protocol used to operate the MODEN Plus Pager Unit requires the following algorithm to be used when the System 85 processor talks with the pager.

The CHAP ignores all characters from the MODEN Plus Pager except the following characters which are listed below along with their meaning.

= Equal Sign: This is the Log In prompt from the pager. The complete message is:  
ID=<CR><LF>

- [ Left Bracket: This message indicates that the pager is ready to accept pages. The complete message is: <ESC>[p<CR><LF>
- <EOT> End of Text: This message completes a log in session on the pager. The complete message is: PAGE EXCHANGE DISCONNECT<CR><ESC><EOT><CR>
- <ACK> Acknowledge: This means that the pager has accepted the message from the sender (PCC in this case). The complete message is: <ACK><CR>
- <NAK> Negative Acknowledge: This means that the pager has not accepted the message from the terminal. The complete message is <NAK><CR>
- <XON> Transmission on: This means that the Motorola buffer is ready to accept messages from the terminal. The complete message is <XON><CR>
- <XOF> Transmission off: This means that the Motorola buffer is full and no more messages should be sent from the terminal. The complete message is <XOF><CR>.

The System 85 encloses the message for the pager as it would a message being sent using the Direct Output protocol. That is, enclosed in a STX/MSN/ETX/BCC format. Upon receiving the message, the CHAP strips the STX/MSN/ETX/BCC overhead and sends the message out to the pager. The pager responds to the message with its ACK or NAK message. If the ACK message is received (remember the CHAP looks for the ACK and trashes the CR), the CHAP updates the DPR indicating that the message has been completed. If the NAK message is received, the CHAP retransmits the message once, and if it is still NAK'd by the pager, the CHAP will lie to the System 85 processor and tell it that the message was sent.

If any of the above characters are received from the pager by the CHAP, they are enclosed in the STX/MSN/ETX/BCC format and sent to the System 85.

#### **USER OPERATION**

See the DESCRIPTION above for each feature.

**INSTALLATION & ADMINISTRATION INSTRUCTIONS**

SD 3970 ISSUE 1.1  
BASED ON R2V3 ISSUE 1.4

**HEALTH, EDUCATION AND SAFETY PACKAGE**

FEATURE PACKAGE PG-3W038

**INSTALLATION PROCEDURE**

These instructions are for use with Special Development 3970. The accompanying Specification Document should be fully understood before one attempts to administer this special development. There are new procedures or fields necessary for this special development.

If upgrading from an earlier issue of this special development or if upgrading from an earlier standard base issue, reference all standard ISCN documents from the standard base issue currently installed through the base issue of the special development.

**PROCEDURE FOR RETROFITTING FROM STANDARD TAPES OR ISSUE 1.0 OF SD3970**

This issue is run tape compatible with 1.X issues of System 85®, R2V3. It is also run tape compatible with issue 1.0 of SD3970. The HEALTH, EDUCATION AND SAFETY PACKAGE features must be installed by the following run tape procedures:

1. With the standard tapes or SD3970, issue 1.0 tapes in the machine, press RUN TAPE, EXECUTE on the MAAP.
2. If trunk group 255 has been administered, display and make note of all trunks in this trunk group. Remove these trunks and remove trunk group 255.
3. If Emergency Alert Dial Access Codes have been administered in a previous issue of the special development (feature access code "59" in Proc 350, Word 2), these should be displayed, recorded and removed.
4. If applicable, follow any procedures as described in the standard ISCN documents.
5. When the run tape completes, insert the special development tape into the on-line tape drive. Press RUN TAPE, EXECUTE again.
6. The Special Development tape now contains the translations of the machine. If this is a duplicated system, move the special development tape from the on-line tape drive to the off-line tape drive, insert another special development tape into the on-line tape drive and press RUN TAPE, EXECUTE again. It is now necessary to load these tapes into the memory of the machine. If this is a duplicated system, proceed from step 8, otherwise continue with step 7.
7. Verify that the on-line Microdiagnostic Test Select switch is set for test 15. Load the special development into memory by depressing the rocker switch entitled 'ENABLE'. After the load is complete proceed to step 11.
8. Verify that the off-line processor's Microdiagnostic Test Select switch is set for test 15. Depress the ENABLE switch in the off-line processor in order to load the new tape.

9. Once the off-line processor is loaded, use hard switch to switch processors. If this customer cannot tolerate any service disruption (i.e. cut-offs), then use Procedure 613, Test 3 to perform a soft switch.
10. Verify that the Microdiagnostic Test Select switch is set for test 15. Depress the ENABLE switch in the processor that now is off-line in order to load the new tape.
11. If any trunks were removed in step 2 re-administer those trunks, adding them to a different trunk group. Trunk group 255 will now have a special use in SD3970, issue 1.1.
12. If Emergency Alert Dial Access Codes were removed in step 3, re-administer them with feature access code "58".
13. With Proc 203 enter a "1" in field 1 and press DISPLAY, EXECUTE, CHANGE, EXECUTE. Repeat with "2" and "3" in field 1.
14. If a standard tape was used in step 1, administer the special development features following the instructions in the next section.
15. Perform a run tape on all, including spare, special development (RED LABELED) tapes.

**WARNING:** Procedure 490 has been disabled. Contact Custom Software Development in Denver for CPCN updates or to apply patches.



**MAAP PROCEDURES TO ADMINISTER "MEET-ME" PAGING**

The following procedures are used to administer "Meet-Me" Paging.

- Procedure 000, Word 1 — Assign Meet-Me Paging Extensions
- Procedure 011, Word 1 — Assign Coverage Paths for Meet-Me Paging Extensions
- Procedure 103 — Administer Automatic "Meet-Me" Paging Pickup via Remote Access
- Procedure 350, Word 2 — Assign Meet-Me Page Pickup Dial Access Code

**Procedure 000, Word 1**

WORD	EXTENSION NUMBER	TERMINAL				C L A S S O F	S E R V I C E	P O R T T Y P E	D I S A B L E D	S I G N A L L I N G	DISPLAY ONLY		P A G E L I N E	S I N G L E T E R M I N A L T R A N S L A T I O N
		E Q U I P	L O C A T I O N								R E C E N T D I S C I P	U S E T H E P R O C ( S ) S H O W N		
1		M O D U L E	C A B I N E T	C A R R I E R	S L O T	C I R C U I T					10	11	12	000

A new field, 12, has been added to this procedure to assign extensions as "Meet-Me" Paging extensions. The extensions may be assigned to send or not send a message to the Motorola paging unit via the PCC. If a message is not used, then the line can be used as a special type of call park and the call can be retrieved by dialing the pick-up code and the number.

Field 12 may have the following values:

- 0 = Not a "Meet-Me" Pager extension
- 1 = A "Meet-Me" Paging extension with a message sent to the PCC
- 2 = A "Meet-Me" Paging extension with no message sent to the PCC

If Field 12 is set to a 1 or 2, then no equipment location may be assigned for the extension. It is only legal to use the change function for "Meet-Me" Paging extensions to change from a multifunction line type to a "Meet-Me" Paging line. All other combinations of changing to and from "Meet-Me" paging extension is prohibited. It is, however, legal to change the Class-of-Service for a "Meet-Me" paging extension.

**SPECIAL ERROR CODE :**

- 95 — You may only change from a multi-appearance terminal line to a page line. Once a page line only fields 7 & 12 may be changed.

**Procedure 000, Word 2**

No fields have been added to or removed from this procedure word.

A "Meet-Me" Pager extension may only be allowed the following features:

- Hunting (field 2)
- Auxiliary ANI (field 3) — Is ineffective for this type of line
- Attendant Control of Voice Terminal Group (field 5)
- Call Coverage (Fields 6 & 7) — Message retrieval is not meaningful for this type of line.

*SPECIAL ERROR CODES:*

- 89 — A page line can only hunt to and be hunted to by another page line
- 90 — Feature may not be assigned to a page line

**Procedure 011, Word 1**

No fields have been added to or removed from this procedure word.

"Meet-Me" Paging extensions may be assigned coverage paths just like any other extension. They may not be assigned as a coverage point.

*SPECIAL ERROR CODE:*

- 92 — Meet-Me page extensions are not allowed to be cover points.

**Procedure 103**

This procedure is used to administer automatic "Meet-Me" paging pickup via remote access.

TRUNK GROUP	FAC	NET	MAIN		AUTH	BRIDGE	TRK		ARR	TRK	UTR	ARR	SECON	RA	RA	DIGIT	AUTO		NETWORK TRUNK GROUP TRANSLATON  103
	REST	WORK	/TAN		CODE	ON	RESER	/ARS	DATA	TRK	COND	COND	FORM	ECHO	COLLECT	PAGE			
	LEVEL	TRK	DEM		REQ	ALWD	VATION	PREFIX	PROTECT	TIMEOUT	ROUTING	TTCM	TRK	SUPPR	PICKUP	ACC			

Assign remote access trunks in the standard manner (with no barrier code or shared LDN's assigned in Procedure 275). For the remote access trunk group assigned in Procedure 100, use field 17 of Procedure 103 to indicate if the trunk group is to be dedicated to picking up "Meet-Me" page calls. When this trunk group is used, the "Meet-Me" page pickup code assigned in Procedure 350 is automatically dialed by the system so the user does not need to dial the code. Otherwise, the remote access feature will operate in the standard manner.

Legal values of field 17 are:

- 1 = Trunk group is dedicated for "Meet-Me" page pickup.  
(Trunk group must be a remote access type).
- 0 = Trunk group not dedicated.

**Procedure 350, Word 2**

This procedure word is used to administer the "Meet-Me" page pickup dial access code. No fields have been added to or removed from this procedure word for this feature.

*NEW FEATURE CODE:*

15 — "Meet-Me" Page Pickup

**ADDITIONAL MAAP PROCEDURE RESTRICTIONS**

**Procedure 026, Word 2**

No fields have been added to or removed from this procedure word.

*SPECIAL ERROR CODE:*

91 — A "Meet-Me" page line may not be an ACD group supervisor.

**Procedure 026, Word 3**

No fields have been added to or removed from this procedure word.

*SPECIAL ERROR CODE:*

89 — A "Meet-Me" page line may not be an ACD group member.

**Procedure 270**

No fields have been added to or removed from this procedure word for this feature.

*SPECIAL ERROR CODE:*

83 — A "Meet-Me" page line may not be a default extension.

**MAAP PROCEDURE TO ADMINISTER THE PROCESSOR COMMUNICATIONS CIRCUIT (PCC)**

**NOTE:** To change existing translations for a PCC, the circuit must be busied out. (See Procedure 651 under Maintenance Procedures.)

**Procedure 255, Word 1**

W O R D  1	A P P L I C A T I O N  N U M B E R	A C T I V E	P R I O R I T Y											D S P O N L Y	P C C  A P P L I C A T I O N  A C T I V A T I O N
				N B R O F C K E T S	T R A N S L A T E D	2 5 5									

Procedure 255 was created to administer the PCC.

Word 1 is used to activate an application.

FIELD	DESCRIPTION	RANGE	DESIRED VALUE
1	Application Number 1 = CDR 2 = ANI 3 = Motorola Pager 4-15 = Unused at this time	1-15	3
2	Active 0 = Application is not active 1 = Application is active	0-1	1
3	Priority  1 = A processor switch will occur if there is an unrecoverable link failure or if no circuit can be found to perform the Meet-Me page function. This includes the use of Procedure 651 to busy out the existing circuit. If the circuit is busied out, and this field is set to a value of 1, a processor switch will take place. If the processor switch is unsuccessful for any reason, the circuit will be retested and released into service. If this is not desired, the user must change the value in this field to a 0 to preclude the processor switch. When first translating the Meet-Me paging application, set this field to a 0. Once the application is functioning correctly, set this field to a 1 if desired. This will avoid any forced switching problems. 0 = A processor switch will not occur if there is a link failure	0-1	Customer Option
4	Number of Circuits Translated (for this application) Maximum supported for this development is 1	0-6	Display Only

**NOTE:** Some applications may not be valid for a particular customer. Error code 71 will be displayed if an attempt is made to administer an invalid application.

ADD and REMOVE are invalid button pushes.  
NEXT DATA will step through all active applications.

**SPECIAL ERROR CODE:**

81 — All circuits must be removed in word 2 before deactivating the application.

**Procedure 255, Word 2**

WORD 2	APPLICATION NUMBER	LOGICAL CKT	LOCATION		STOP BITS	CHAR LENGTH	DATA TYPES				WATERMARKS				PCC LINK ATTRIBUTES			
			SLOT	CIRCUIT			BAUD	PARITY	501 PCC	PCC	PER PCC	PCC 501	OUT			IN		
													LOW	HIGH		LOW	HIGH	
	1	2	3	4	5	6	7	8	9	10	11	12	13	14	15	16		

This word provides 4 functions:

- a. assignment of PCC's to specific applications
- b. change/display a particular PCC's link attributes
- c. change/display the list of PCC's ordered for use by a particular application
- d. if fields 3 and 4 are both dashed and a change/execute button push is detected, this becomes a remove operation - the circuit will be removed from the list of circuits ordered for use by the given application and all attributes in words 2 and 3 pertaining to that circuit will revert to the desired values.
- e. if fields 3 and/or 4 are changed to new value(s) and a change/execute button push is detected, then word 3 values will revert to the desired values.

Note that:

- PCC circuits must be busied out before they may be removed.
- The slot and circuit associated with an application and logical circuit number may not be changed. To use a different PCC circuit, first remove the current circuit, then add the new circuit in word 2 and word 3.
- Only one PCC circuit is permitted with the meet-me paging application. Attempts to translate a second will give an error code 12.

A description of each field and their desired values follows.

FIELD	DESCRIPTION	RANGE	DESIRED VALUE
1	Application Number	1-15	3

1 = CDR  
 2 = ANI  
 3 = Motorola Pager  
 4-15 = Unused at this time

2	Logical Circuit Number -- represents the order of use for the PCC in fields 3 & 4	1-6	1
3	Slot Location	24-26	Start with 26
4	Circuit Location	0-1	Start with 0
5	Baud 1 = 110 baud 2 = 300 baud 3 = 600 baud 4 = 1200 baud 5 = 2400 baud 6 = 4800 baud 7 = 9600 baud 8 = 19.2k baud	1-8	4
6	Parity 0 = no parity 1 = not used 2 = odd parity 3 = even parity	0-3	3
7	Number of stop bits 1 = 1 stop bit 2 = 1.5 stop bits 3 = 2 stop bits	1-3	1
8	Character length 0 = 5 bit characters 1 = 6 bit characters 2 = 7 bit characters 3 = 8 bit characters	0-3	2
9,12	Data type used between 501cc and peripheral 0 = 4 hex nibbles 1 = 2 ascii characters	0-1	0
10,11	Data type used between PCC and the peripheral 0 = 2 hex nibbles 1 = 1 ascii character	0-1	0
13	PCC low watermark for outgoing FIFO	0-7	1
14	PCC high watermark for outgoing FIFO	0-7	7

15	PCC low watermark for incoming FIFO	0-7	1
16	PCC high watermark for incoming FIFO	0-7	7
	0 = less than 1k		
	1 = greater or equal to 1k but less than 2k		
	2 = greater or equal to 2k but less than 3k		
	3 = greater or equal to 3k but less than 4k		
	4 = greater or equal to 4k but less than 5k		
	5 = greater or equal to 5k but less than 6k		
	6 = greater or equal to 6k but less than 7k		
	7 = greater or equal to 7k but less than 8k		

**NOTE:** Some applications may not be valid for a particular customer. Error code 71 will be displayed if an attempt is made to administer an invalid application.

NEXT DATA will step through all applications which have PCC circuits assigned.

*SPECIAL ERROR CODES:*

- 81 — To remove a logical circuit assignment, dash fields 3-4 and change execute
- 82 — The application must be activated in word 1 before assigning logical channels
- 83 — Circuit must be a PCC
- 84 — Fields 9 and 12 must be equal
- 85 — Fields 10 and 11 must be equal
- 86 — High watermark cannot be less than the low watermark
- 87 — Circuits must be added in order
- 88 — Use Procedure 651 to busy out circuit
- 89 — Unable to read or write PCC of dual port RAM. Use PROC651 to determine failure cause.

**Procedure 255, Word 3**

Word 3 administers additional PCC link attributes. A description of each field and their default values follow:

WORD 3	APPLICATION NUMBER	LOGICAL CKT	COMMUNICATING WAY	MESSAGE LENGTH	MESSAGE LENGTH	PROTOCOL	PERIPHERAL NUMBER	FAILURE THRESHOLD											PCC LINK ATTRIBUTES
																			255

FIELD	DESCRIPTION	RANGE	DESIRED VALUE
1	Application number 1 = CDR 2 = ANI 3 = Motorola Pager 4-15 = unused at this time	1-15	3
2	Logical circuit number	1-6	N/A
3	1 or 2 way communication 0 = 1 way communication 1 = 2 way communication	0-1	1
4	Message length format 1 = message length is contained inside the message 2 = message will be delimited by STX and ETX 3 = fixed message length	1-3	2
5	Message length	1-128, or dash	-
6	Type of Protocol 1 = direct output (no protocol) 2 = BTC Protocol 3 = "in message protocol" 4 = Motorola protocol	1-4	4
7	Peripheral number this PCC is assigned to	1-6	Customer Option
8	Number of consecutive messages which may fail before the PCC stops and waits for 501cc intervention	1-15	Customer Option

NEXT DATA will step through all applications which have circuits assigned.

*SPECIAL ERROR CODES:*

- 81 — Use word 2 to assign logical circuits to application
- 82 — Message length must be assigned for formats 1 and 3
- 83 — Message length field must be blank for format 2
- 84 — Use procedure 651 to busy out circuit
- 85 — Unable to read or write dual port RAM of PCC. Use PROC651 to determine failure cause

**NOTE:** Some applications may not be valid for a particular customer. Error code 71 will be displayed if an attempt is made to administer an invalid application.



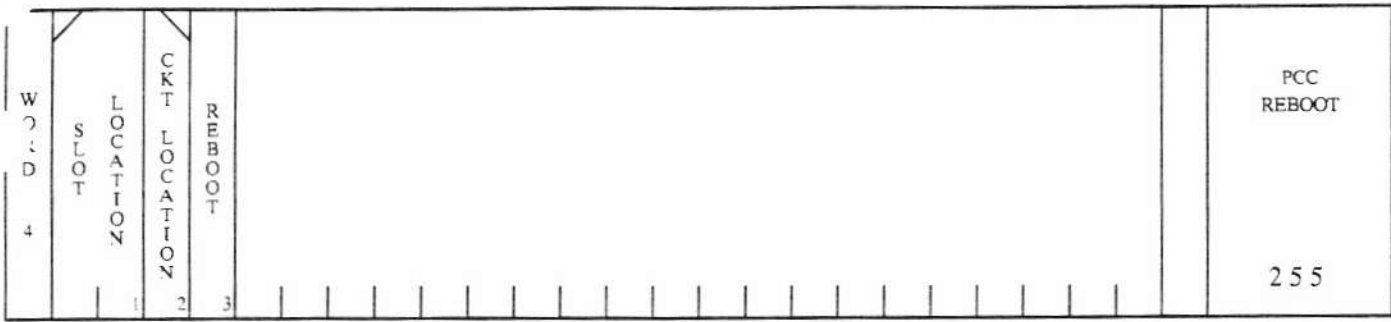

Word 4 may be used to re-initialize the PCC after any attributes in Words 2 and 3 have been changed. Alternatively, PROC 651, Tests 2 or 3 may be used to release the busy circuit. PROC 255, Word 4 performs essentially the same function as a release busy out in PROC 651, Test 2 or Test 3. A description of each field follows.

FIELD	DESCRIPTION	RANGE
0	Word 4	
1	Slot Location	24 - 26
2	Circuit Location	0 - 1
3	Reboot 1=Reboot this circuit	1

*SPECIAL ERROR CODES:*

- 81 — Use Procedure 651 to busy out circuit.
- 82 — Reboot failed. Use Procedure 651 to determine failure cause.

**MAINTENANCE PROCEDURES**

**Procedure 651**

This Procedure provides a means by which PCC circuits may be tested and their failure causes displayed. It contains 4 tests which should provide the needed information to indict a particular piece of hardware in the PCC link so that it may be replaced and correct functionality restored. These tests are:

1. This test provides a limited history of the fatal failures encountered by each PCC circuit and the ability to resolve them. All fields in this test should be considered 'display only'.
2. This test requests that a PCC test itself and monitors it while it does so. Any errors found by the PCC or the failure of the PCC to complete the test will be reported in fields 7 and 8.
3. This test performs a local loop around through the PCC circuitry to verify that the PCC can successfully pass messages, handle protocol and detect errors purposely caused in message transmission by this test.
4. This test sends a message (or messages) to the distant peripheral and verifies that the response from that peripheral is the expected response. It is not valid for all applications (for instance Motorola paging) and will display error 86 if this is the case and an attempt is made to perform test 4 on a circuit belonging to an invalid application.

For more specific details on the operation of these tests, see their individual sections below.

TEST NO	EQUIPMENT LOCATION			ALARM STATUS	CIRCUIT STATUS	FAILURE INDEX	FAILURE CODE	TEST 4	TEST 4	T 4	T 3	PROCESSOR COMMUNICATION CIRCUIT TEST
	CARRIER	SLOT	CIRCUIT					# OF MESSAGES FAILED	NUMBER OF TESTS PASSED	CORRUPT TESTS ONLY	W/ LOOP CABLE	
1	2	3	4	5	6	7	8	9	10	11	12	651

A description of each field follows.

FIELD	DESCRIPTION	RANGE
1	Test Number 1 = display/resolve failure history 2 = perform PCC circuit self test 3 = perform PCC local loop around test 4 = perform PCC to peripheral end to end loop around test	1-4
2	Carrier in which PCC circuit resides (display only)	0-1
3	Slot Location	24-26
4	Circuit Location	0-1
5	Alarm Status (display only field) 0 = no errors recorded 1 = major alarm 2 = minor alarm 3 = warning	

	4 = errors recorded (no alarm yet)	
	5 = alarm resolved	1-5
6	circuit status (display only field)	
	0 = untranslated circuit	
	1 = translated and busied out	
	2 = translated and in service	
	3 = translated, in backup mode, ready for service	
	4 = translated and in test	
	5 = circuit busy, must pass test before it may be released for service	0-5
7	Failure Index	
	Failure number currently displayed in field 8	0-5
8	Fault Code	
	Specific Fault Code (SFC) of failure (see Trouble Analysis for SFC meanings)	11-71

NEXT CIRCUIT will step through all translated circuits in the system. NEXT TEST will loop through the 4 tests that make up the Proc. NEXT FAULT will step through the fault codes if more than 1 exists.

#### *SPECIAL ERROR CODES:*

- 80 — Busy-out key pressed once (press again to complete busy out)
- 81 — Circuit must be busied out before test can be run
- 82 — Test 4 can only be run from online processor
- 83 — Busy-out had to be forced due to error. Messages may have been lost.
- 84 — Circuits may not be released from 'busy' state unless they pass a test.
- 85 — No failures are recorded for PROC to display.
- 86 — No test message exists for use in executing Test 4.
- 87 — Peripheral in service by another PCC. Circuit Test 4 may not be run.

#### **Test 1**

Test 1 is the default test number, brought up upon invocation of Proc 651. Depression of the EXECUTE button for the first time causes the number of failures (or zero if there are none) to appear in field 7. Depression of CLEAR DATA EXECUTE resolves the alarms. Press the NEXT CIRCUIT or NEXT FAULT key to step through the logged failures.

#### **Test 2**

Test 2 comes up with the first translated circuit displayed in fields 2-4. It also displays the current alarm and circuit status for this circuit. To advance to the next translated circuit, simply press the NEXT CIRCUIT

key. To advance directly to the desired circuit, perform a CHANGE FIELD 3 EXECUTE and then enter the desired slot number ENTER and the desired circuit number ENTER. At this time the current alarm and circuit status for the new circuit will be displayed.

In order to execute this test on a given circuit, the circuit status field must be either a 1 or a 5. If the circuit is in service (2) or backup (3), then the circuit must be busied out by depressing the BUSY OUT key twice. The first depression will give an error 80 to let you know that you are removing an active circuit from service. If the circuit is in status 4, then depress EXECUTE button and wait for busy lamp to be extinguished. NOTE that if the priority bit in Procedure 255, word 1 is set, that a busy out of the circuit will cause a processor switch to be attempted. If that switch attempt fails, the circuit will be retested and released automatically. To avoid this, zero the priority bit in Proc 255, word 1 before performing the busy out here.

Once the desired circuit is in the correct state (status = 1 or 5), press the EXECUTE button. This will start the test and change the circuit status to 4. Please do not try to perform any other actions on the MAAP until the wait lamp is extinguished and the circuit status is updated. If you do, some tests will continue to run in the background, but others will be canceled and the circuit marked busy (5).

Completion of a test is marked by the extinguishing of the wait lamp and the updating of the circuit status field. A status of 1 means that the circuit has passed the test. A status of 5 means that the circuit has failed the test and the cause(s) for the failure are displayed in field 8 (see TROUBLE ANALYSIS section for fault codes). Should there be more than 1 failure cause (i.e. 2 bad components on the circuit) then press the NEXT FAULT key to display the additional causes.

If a circuit passes the test, it may be released for service by pressing the RELEASE BUSY OUT key. At this point, the circuit status will change to 3, indicating that the circuit is ready for use if needed. Further, if the application which owns this circuit has been doing without while the test was being run, then the circuit status will change to 2 within a few seconds. Attempts to release a circuit for service when it has failed a test will result in an error code.

### Test 3

Test 3 comes up with the first translated circuit as test 2 did. The same NEXT CIRCUIT step through the translated circuits exists also. To execute this test on a circuit follow the same busy out steps and execute as in test 2. Once done with this test, a circuit which has passed it may be released as above. NOTE that if the priority bit in Procedure 255, word 1 is set, that a busy out of the circuit will cause a processor switch to be attempted. If that switch attempt fails, the circuit will be retested and released automatically. To avoid this, zero the priority bit in Proc 255, word 1 before performing the busy out here.

Execution of this test results in the PCC circuit being put into an internal loop mode and sending messages (both good and error filled) through the circuit with the send and receive sections speaking to one another as if they were separate devices. However, this does not test the wiring to the Series 300 connector on the back of the common control cabinet. To test this wiring, use test 4. It is not recommended that field 12 of this Proc be used in the field because the cable required to do so will disconnect other links which are using the Series 300 connector. That field is primarily intended for use in the manufacturing environment and in drastic field situations.

A test must be executed before RELEASE BUSY OUT will function.

### Test 4

Test 4 also comes up with the first translated circuit displayed and uses the above detailed NEXT CIRCUIT method to step through translated circuits. Again, the busy out steps are required before an active circuit may be tested. After successful operation of this test, the PCC circuit may be released for service.

Execution of this test results in a message(s) being sent out to the peripheral device over the given PCC link. The message that is passed has a known correct response, depending on the type of peripheral that translations indicate is on the other end. The test therefore, sends out the message and compares the response with the expected response (if any). If the response does not match the expected response or does not come back in a reasonable period of time, then the circuit is marked "busy" and the wait lamp extinguished. As usual, the

error code explaining the failure is displayed in field 8 and the number of attempted messages and failed messages are displayed in fields 9 and 10.

There is an option on this test to run multiple messages through the process described in the previous paragraph. To do this, simply perform a **CHANGE FIELD** to field 11 and enter a 1 there before pressing **EXECUTE**. In the current implementation of this procedure, this results in a rapid sending of 50 messages and then a waiting period to verify that each message received the correct response. Future implementations will send one message per second until the **STOP** button is pressed.

## MAAP PROCEDURES TO ADMINISTER MALICIOUS CALL TRACE

Five existing procedures have been modified to administer this development. These procedures operate in their normal manner except that new encodes have been added for this development. The modified procedures are as follows:

- Procedure 054, Word 1 — Assign Terminal feature button
- Procedure 100 — Assign Trunk Group
- Procedure 150 — Assign Trunk Circuit
- Procedure 203 — Assign Console Control Key
- Procedure 350, Word 2 — Assign Feature Dial Access Code

### Procedure 054, Word 1

This procedure is used to assign and remove feature keys on multi-button sets. This procedure has been modified to allow administration of the Malicious Call Trace activate key on multi-button sets.

#### *NEW KEY ENCODE*

31 — Malicious Call Trace Activate

### Procedure 100

This procedure is used to assign the trunk type to a trunk group. A new trunk type has been activated for the Malicious Call Trace Recorder. Only one trunk group of this type is allowed to be assigned in the system.

#### *NEW TRUNK TYPE*

93 — Malicious Call Trace Recorder

### Procedure 150

This procedure is used to assign an auxiliary trunk circuit to the Malicious Call Trace recorder trunk group. Only one recorder is allowed to be assigned in the system.

### Procedure 203

This procedure is used to assign the console control keys. Two new control keys are used by this development. The Malicious Call Trace Activate Key is used by the attendant to start a trace on the active switch loop. The Malicious Call Trace control key is used by the attendant to control a malicious call trace and to step the display of the call information.

*CONTROL KEY ENCODES*

- 31 — Malicious Call Trace Activate
- 30 — Malicious Call Trace Control

**Procedure 350, Word 2**

This procedure is used to assign the feature dial access codes. The Malicious Call Trace Activate feature is used by a station user to activate the trace on itself or another extension. The Malicious Call Trace Deactivate feature is used by the attendant to deactivate the Malicious Call trace.

*FEATURE ENCODES*

- 34 — Malicious Call Trace Activate
- 35 — Malicious Call Trace Deactivate

## MAAP PROCEDURES TO ADMINISTER ATTENDANT DIRECT

The following instructions are necessary for installation and administration of the Attendant Direct feature. This feature uses a new set of translations known as attendant groups. An attendant group may consist of zero, all, or any combination of attendant consoles. Calls from (1) any incoming trunk group, (2) any LDN, or (3) dial '0' calls from any LCOS, may be routed to any attendant group. When certain conditions occur, an attendant group can be bypassed and the call will be processed by another attendant group. This operation will be known as overflow. When overflow does not occur, the call waiting lamps will be lit on attendant group where there are calls waiting. Any incoming trunk group, LDN, or LCOS that is not assigned to an attendant group will go to any attendant.

Only incoming trunk groups, LCOSs, and LDNs may be assigned to specific attendant groups.

### DEFINITIONS

**Attendant Group** - A customer defined group of one or more attendant consoles to which trunk groups or LDNs may be routed; calls may be routed directly or through an overflow condition.

**Overflow** - A condition in which a call cannot be routed to an attendant group because none of the attendants are available. This condition will be defined by the overflow type.

**LDN** - A Listed Directory Number.

**Overflow Group** - An attendant group to which another attendant group may overflow.

**Overflow Type** - Defines what condition is necessary on all of the attendant consoles in the assigned attendant group for overflow to take place. The overflow type may be either 0 or 1:

- 0 - Overflow will occur only when all of the attendant consoles in the attendant group have been "position busied" or have had their headsets removed.
- 1 - Overflow will occur when either (a) all of the consoles in the attendant group have been "position busied" or have had their headsets removed, or (b) all of the switched loops on all of the consoles in this group are busy.

### ACRONYMS and ABBREVIATIONS

AG	Attendant Group
ATND	Attendant
ICI	Incoming Call Identification
LCOS	Line Class-of-Service
LDN	Listed Directory Number
TG	Trunk Group

### DESCRIPTION

The assignment of LDNs, trunk groups, or LCOSs to specific attendant consoles is done via attendant groups. Up to 15 attendant groups may be defined. Each group is comprised of one or more attendant consoles. A console may be a member of only one attendant group.

In the case where a call is routed to an attendant group in which all the consoles are busy, this attendant group may be bypassed and the call routed to an overflow group. An overflow group is another attendant



group used when the overflow condition occurs. Therefore, an attendant group may be used as an attendant group, overflow group, or both. For example, trunk group 28 may be assigned to attendant group 1 and attendant group 1 may overflow to attendant group 5, while at the same time trunk group 29 may have group 5 as its assigned attendant group. There is only 1 overflow group assignment for each attendant group. It is not possible to have TG 28 assigned to attendant group 1 overflowing to group 2, while TG 29 is assigned to attendant group 1 overflowing to group 3. In addition, attendant group zero may not be assigned as an overflow group.

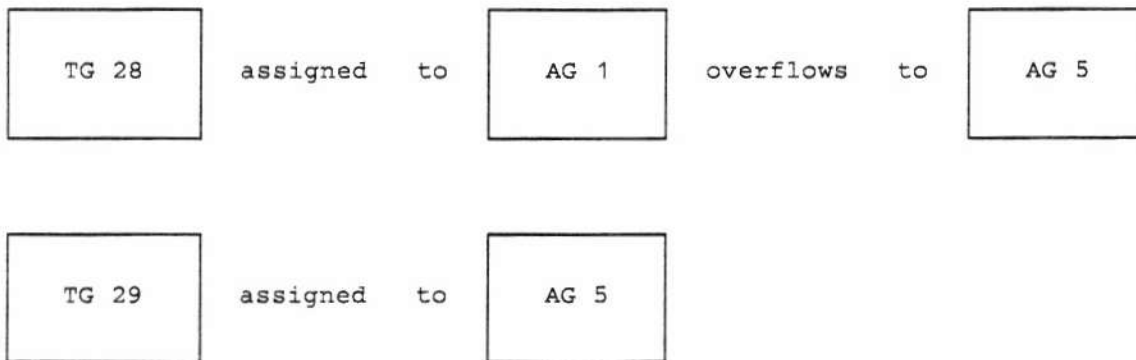

The overflow type (0 or 1) determines what conditions on all of the consoles in the attendant group are necessary before this group is considered busy. These conditions (type 0 or type 1 conditions described above) must prevail on all of the attendant consoles before a call may be routed to an overflow group. There is one overflow type (0 or 1) for each attendant group and this defines how overflow is determined for this attendant group.

Now consider the case where attendant group 1 overflows to group 2 which in turn overflows to group 3. If a call is assigned to group 1 and overflows to group 2, group 2 may in turn overflow to group 3. This type of chaining is limited to 2 overflow groups. In this manner, the number of groups to which a call may overflow is limited to 2 overflow groups. Procedure 210, Word 2 which administers these overflow groups will allow any number of groups to be linked together. However, in operation, a call may overflow to a maximum of 2 overflow groups. The on-line software does this check since Procedure 210, Word 2 allows any number of groups to be logically linked together.

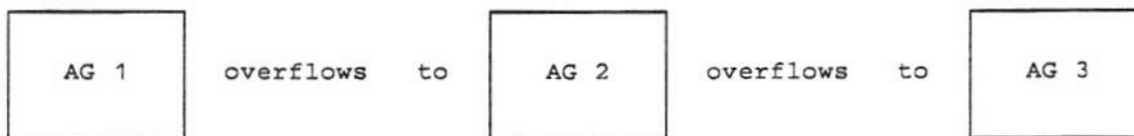

## MAAP PROCEDURES

Four MAAP procedures are used to administer this feature. These are:

- Proc 210, Word 1 - assigns attendant consoles to attendant groups.
- Proc 210, Word 2 - assigns attendant group information (overflow group, overflow type).
- Proc 204 - assigns trunk groups and LDNs to attendant groups.
- Proc 010, Word 2 - assigns LCOS to attendant groups.

Attached are three work tables that must be used in conjunction with these instructions.

**TABLE 1 - ATTENDANT GROUPS - Procedures 210, Word 1 and PROC 210, Word 2**

Table 1 sets up the attendant group definitions. For each attendant group (1-15) to be translated, fill in the vertical column containing the overflow group (1-15), the overflow type (0 or 1), and circle the attendants (1-40) that will be in that group. This table should be filled out completely before using the procedures to administer the translations.

Once all entries to Table 1 have been made, Procedure 210, Word 1 should be used to assign attendants to attendant groups. After this is done, Procedure 210, Word 1 should be used to administer overflow groups and types to attendant groups. NOTE: an attendant group may not be assigned via Procedure 010, Word 2 or 204 unless the group contains at least 1 console.



*TABLE 2A -- LCOS TO ATTENDANT GROUP -- Procedure 010, Word 2*

Table 2A should contain each LCOS that is to be attendant directed. Any station whose LCOS is not assigned to an attendant group will have all dial '0' calls routed to any attendant in the system. Any number of LCOSs may be assigned to an attendant group, therefore LCOSs that are to be routed to the same group of attendants should be assigned the same attendant group.







Procedure 010, Word 2

WORD 2	CLASS OF	SERVICE	LEAVE WD CALLING		SM DR	RE AC C C O D E	A T T E N D A N T	G R O U P	E M E R G E N C Y	O U T A L E R T	A U T O T E R M R E S T R I C T	B Y								TERMINAL CLASS OF SERVICE FEATURES
			O R I G	T E R M																

Word 2 of this procedure is used to assign an attendant group to a LCOS. Field 6, the ATND GROUP field is where the assignment is made. Initially, all LCOSs are assigned to attendant group zero, which means that a dial '0' call will go to any attendant in the system. An attendant group must be assigned to at least one console via Procedure 210, Word 2 before it can be assigned to a LCOS. Field 6 may range in value from 0-15. REMOVE EXECUTE or ADD EXECUTE have no effect on field 6; CHANGE EXECUTE must be used to change field 6.

Procedure 204

WORD 1	TRUNK GROUP/ CALL TYPE	M E S S A G E  N B R	C A S E  N B R	ALPHA CHARACTER				L I S T E D  D I R E C T O R Y  N U M B E R	A T T E N D A N T  G R O U P				CONSOLE MESSAGES/ LISTED DIRECTORY NUMBER (LDN)
				1	2	3	4						

This procedure may be used in two different ways for the Attendant Direct feature.

The first way is to assign a trunk group to a ICI message number, message, and attendant group (using fields 1 - 6, 8). ADD EXECUTE adds an ICI message to each trunk group and also adds the attendant direct information. An ICI message number must be added when using ADD EXECUTE. REMOVE EXECUTE removes the ICI assignment and the attendant group assignment. An ICI message number of 0 means that this entry is not assigned.

The second way is to assign an LDN to the system and assign a message and attendant group to it (using fields 1 - 8). Call types 281 through 289 are dedicated for the nine possible LDN's. ADD EXECUTE is used to add an LDN and associated information to the system. REMOVE EXECUTE is used to remove the LDN from the system. NEXT DATA steps the LDN field. CHANGE EXECUTE may not be used to modify this message or attendant group, you must use REMOVE followed by ADD.

The following table defines the technician's character codes:



2nd DIG.		0	1	2	3	4	5	6	7	8	9
D 1 I s G t I T	1	blank	A	B	C	D	E	F	G	H	I
	2	J	K	L	M	N	O	P	Q	R	S
	3	T	U	V	W	X	Y	Z	-	-	-

An attendant group may not be assigned via procedure 204 unless the group contains at least 1 console, otherwise an error 03 will occur for field 7.

**Procedure 210, Word 1**

WORD 1	CONSOLE	NUMBER	ATTENDANT INTERFACE EQUIPMENT LOCATION				DATA CHANNEL EQUIPMENT LOCATION				ATTENDANT GROUP	DISPLAY ONLY		CONSOLE EQUIPMENT LOCATION	
			MODULE	CABINET	CARRIER	SLOT	CIRCUIT	CARRIER	SLOT	CIRCUIT		ON REMOVE SEE NOTE FOR ERROR CODE DISPLAYED WHEN NON_BLANK			
			1	2	3	4	5	6	7	8	9	10		11	210

Field 10, attendant group, defines the attendant group of which a console is to be a member. Remember, an overflow group is an attendant group with a special use. Attendant groups must be defined before anything can be assigned to them in Procedure 204 or Procedure 010, Word 2. Exactly as this procedure previously functioned, only the highest numbered console may be removed from an equipment location. Console 1 may not be removed from its equipment location without first removing console 2. An attendant console may always be removed if it is in attendant group 0. If it is any other attendant group it may not be removed if it is the last console assigned to that attendant group and there exists any combination of LCOS, TG or LDN directed to that attendant group or there is another attendant group which overflows to this group. If a remove of this type is attempted, then Field 11, a display only field, will display a LCOS, TG, LDN or overflow attendant group number whose attendant group assignment must first be removed before the console can be removed. There are four new error codes which will indicate the type of the value displayed in Field 11.

**SPECIAL ERROR CODES:**

- 84 — LCOS in field 11 is still assigned to this attendant group
- 85 — Trk group in field 11 is still assigned to this attendant group
- 86 — LDN index in field 11 is still assigned to this attendant group
- 87 — Attendant group in field 11 still overflows to this attendant group
- 88 — This attendant group still overflows to the attendant group in field 11

**Procedure 210, Word 2**

WORD 2	ATTENDANT GROUP	OVERFLOW GROUP	OVERFLOW TYPE	DISP ONLY	ATTENDANT GROUPS
				CONSOLE	
	1	2	3	4	210

Procedure 210, Word 2 now has a completely new use. It is used to assign attendant group information.

Field 1 is the attendant group that is to be displayed/added/changed. Valid range is 1 through 15.

Field 2 is the overflow group associated with the attendant group. Valid range is 1 through 15, "Dash" = no overflow group.

Field 3 is the overflow type. Valid range is 0 through 1.

- Dash = overflow not assigned.
- 0 = position busy, headset removed.
- 1 = position busy, headset removed, or all switch loops busy.

Field 4 displays, one at a time, the console number of attendants that are in that attendant group. STEP displays the next attendant in that group.

To remove an overflow group from an attendant group, enter a 0 in field 2, overflow group, and depress CHANGE - EXECUTE.

Overflow groups and overflow types cannot be removed unless at least 1 console is assigned to the attendant group in field 1.

**MAAP PROCEDURES TO ADMINISTER SPLIT NIGHT SERVICE**

**INTRODUCTION**

Procedure 275, Word 2 is no longer used to administer the default night station. Each attendant group must be allowed to individually be directed to its own default night station, a new Procedure, 270, Word 1, has been added to allow this assignment. Any attempt to assign a night station in Procedure 275 will result in an error code 83.

**Procedure 270**

ATTENDANT GROUP	DEF A U L T	E X T E N S I O N	DISPLAY ONLY		NIGHT STATION
			C O M M O N	E X T E N S I O N	
1		2		3	270

This procedure will provide for assigning a default night extension by attendant group. It will also display the common night extension for each attendant group. Attendant groups with no consoles assigned may not be assigned default night extension. Extensions must be valid numbers in the system dialing plan.

*SPECIAL ERROR CODES:*

- 81 — The default extension must be a working extension, but cannot be an associated extension.
- 82 — No consoles belong to the input attendant group.
- 83 — A Meet-Me page line may not be a default extension.

**MAAP PROCEDURE TO ADMINISTER TWO-WAY ATTENDANT SPLITTING**

**Procedure 203, Word 1**

A new console control key encode has been added to allow for the assignment of the split called key. The split calling key will use the same encode that has always been used under the name SPLIT KEY.

*CONTROL KEY ENCODES:*

- 4 — Split Calling Party
- 32 — Split Called Party



86 —Only 10 Emergency Alert Dial Access Codes allowed.

**Procedure 275, Word 4**

WORD 4	DIGIT CALL	TRUNK XFER	ATND REL LOOP		DEFAULT RECENT DISCONNECT INTERVAL	MAX PRE- EMPT LEVEL		AUTOVON INTERFAC SWITCH NO	ACD ABANDON SEAR ANSWER	SUPERVISOR ACTIVE	ADMIN ALARMS				DISP ONLY		EMERGENCY DACC	SYSTEM COS MISC  275
			ACTIVE	TIMED RECALL		INCOMING ALL	OUTG TERMINAL ATND				PERIPHERAL PORT	TRUNK SUFFIXARY	LOCAL SWITCH					

This procedure contains an Emergency Alert System Class-of-Service field. Field 18 indicates if the emergency dial access code will be restricted to the Classes-of-Service that are under emergency surveillance or if any station can dial it. A zero (0) in this field will make the emergency dial access code accessible only to those stations that are under emergency surveillance. Procedure 010, Word 2 must be used to assign the feature to a Class-of-Service. A one (1) in field 18 indicates that any Class-of-Service can dial the emergency access code. This system Class-of-Service field does not affect the time out access to the feature. That remains Class-of-Service dependent.

**Procedure 204**

This procedure is used to translate the emergency ICI message that appears on the console. There are in total 11 ICI messages possible with this feature. One message for the time out case and 10 messages, one each for the 10 dial access codes.

**NEW CALL TYPES:**

- 309 — assigns the ICI message for the emergency alert time out case
- 310 - 319 — assigns the ICI messages for the 10 emergency alert DAC's as ordered in Procedure 350, Word 2.

**MAAP PROCEDURES TO ADMINISTER AUTOMATIC TERMINATION RESTRICTION BY TIME-OF-DAY**

**Procedure 010, Word 2**

WORD 2	CLASS OF SERVICE	LEAVE WD CALLING		CAL L F WD	S M D R AC CT C O D E	A T T E N D A N T	G R O U P	E M E R G E N C Y A L E R T	A U T O T E R M R E S T R	B Y T I M E O F D A Y											TERMINAL CLASS OF SERVICE FEATURES
		O R I G	T E R M																		010

This procedure defines Classes-of-Service by enabling or disabling any of the features in the words of this procedure. In Word 2, a new field, field 8, has been added for the Auto Termination Restriction by Time-of-Day feature. Entering a "1" in this field will enable the automatic restriction and at the specified start time all stations in the Class-of-Service will be termination restricted and at the specified stop time all the same stations will have termination restriction removed. Entering a "0" in this field will render this feature inactive for this Class of Service.

**Procedure 284**

H O U R	M I N U T E	M O N T H	D A Y	Y E A R	DISP ONLY		A U T O T E R M I N A T I O N R E S T R I C T I O N				S Y S T E M  C L O C K	
					D A Y O F W E E K	C L O C K	S T A R T H O U R	S T A R T M I N U T E	S T O P H O U R	S T O P M I N U T E		
												284

This procedure has been modified to allow for the assignment of the start and stop times for the Automatic Termination Restriction by Time-of-Day. The start time specified in fields 8 and 9 will be the time which the system will search through all the lines and turn on termination restriction if a line's Class-of-Service has this feature enabled. The stop time specified in fields 10 and 11 will be the time at which the system will search through all the lines and turn off termination restriction if a line's Class-of-Service has this feature enabled.

**WARNING:** Be careful when doing a CHANGE/EXECUTE because this will modify the system clock in Fields 1 & 2.



**Procedure 289**

This procedure has been modified to allow for three new intercept types to be used with the Automatic Termination Restriction feature. If a call is restricted based on this feature the three new types will determine how the call should be handled.

<i>TYPE</i>	<i>SOURCE</i>
4	PUBLIC
12	PRIVATE
20	TERMINAL

**MAAP PROCEDURES TO ADMINISTER EMERGENCY ACCESS OF TRUNKS BY ATTENDANT**

**Procedure 203, Word 1**

A new console control key encode has been added to allow for the assignment of the emergency access of trunks activation key. Depression of this key prior to dialing an external call will guarantee the access of an external trunk even if it means the preemption of an existing conversation.

*NEW CONTROL KEY ENCODE:*

35 — EMERGENCY ACCESS OF TRUNKS ACTIVATE

**MAAP PROCEDURE TO ADMINISTER ATTENDANT SERVICE OBSERVING**

**Procedure 350, Word 2**

This is used to assign the attendant service observing dial access code. This dial access code will allow attendants access to the Attendant Service Observing feature when the proper conditions exist, (see SD 3970 Specification Document).

*NEW FEATURE ENCODE:*

39 — ATTENDANT SERVICE OBSERVING

**MAAP PROCEDURE TO ADMINISTER TIME-OF-DAY AND CALLS IN QUEUE DISPLAY****Procedure 203, Word 1**

Two new console control key encodes have been added to allow for the assignment of these two new buttons. The time-of-day button will display the current time in the ICI field using four characters in military notation. The calls in queue button will display in the ICI field the number of calls in queue for the attendant group of the activating console.

*CONTROL KEY ENCODES:*

- 33 — Time-of-Day
- 34 — Calls in Queue

## TROUBLE ANALYSIS

Should you encounter problems with your PCC boards or the feature that it provides on your System 85, follow the instructions below to identify the cause of the trouble. However, by far the most problems experienced are due to translation errors. Therefore, it is recommended that you refer to the administration section above to ensure that the translations are correct. Be sure to verify that the translations on the CDRU or other peripheral agree with what is translated on the switch.

1. Proceed to Proc 600, and look for any faults on Unit Type 75. If any appear there, then note the information provided and go on to step 2.
2. Select Proc 651 on the MAAP. Execute Test 1 and record all errors which appear there. Make special note of the particular circuit(s) reported there for use in the subsequent steps.
3. Press 'NEXT TEST' to get to test 2 and then 'NEXT CIRCUIT' until the location of the circuit causing the trouble is displayed. Write down the alarm status and circuit status field values (fields 5 and 6, respectively).

If the circuit status is not 1, 2 or 3, then we have a problem. This means that we are experiencing an outage. If the value is a 5, then it is considered a 'hard' outage, which means that without your intervention, this circuit would not recover. Proceed directly to step 5. If, on the other hand, the value there is a 4, then the switch is attempting to revive your PCC. It should do so within the next 2 minutes if the device on the other end is powered-up and providing the DTR signal required by the PCC circuit. If it is powered up and providing DTR, but does not recover, then proceed to step 4.

4. Go back to Proc 651, test 1 and display the error associated with the circuit in question. Now do a 'CLEAR DATA' 'EXECUTE' and wait for another fault to be logged against that circuit. This should take only about 30 seconds. Record this error and move on to step 5.
5. Go to Proc 651, test 2 and execute the test. You may be asked to busy the circuit out first. Do so and then execute the test on the circuit you're debugging. If it fails, record the error and try again. If it fails twice, then the PCC is in need of replacement. If it failed one time or not at all, proceed to step 6.
6. Go to test 3 and execute it on the same circuit as in step 5. A single failure should not take place, but if it does, record the fault and try again. Another failure indicates that replacement of the PCC is required.
7. At this point we have assured ourselves that something is definitely wrong. A data analyzer will be required to figure out what it is that needs to be replaced. Insert the analyzer into the link as a monitor only. It should be placed between the ADU and the peripheral.

Set it up so that the baud rate, character length and parity agree with what is translated in Proc 255. Also set it up so that it expects to monitor ASCII and ASYNCH, with the number of stop bits translated in Proc 255.

Does the analyzer see DTR? If not, replace the cable between the analyzer and the peripheral. If that doesn't work, then the peripheral is broken. If DTR is present, clearing the fault on the circuit and releasing the circuit after testing should not result in an error 71. If it does, replace the ADU and the cable from it to the cross-connect field. If that doesn't fix it, then rewire the D-connector to the cross-connect field. If that doesn't do it either, replace the PCC. Only after the above options have been verified at least twice should the backplane be suspect.

Any error in the 40's or 60's indicate a problem with the PCC. Note the specific error number and the conditions which caused it and replace the board. Please include the error number and symptoms in the box with the broken board, so that we, in Denver, know what to look for when we attempt to fix it. Note that error 62 may indicate a problem in the protocol between the PCC and peripheral when BTC protocol is used and not a PCC hardware problem. This can be determined by inserting a data analyzer between the PCC and peripheral and observing the protocol.

Errors in the 10's and 20's indicate a problem between the Buffered Bus on the System 85 and the Board. Replacement of the PCC with a known good one will identify which piece of equipment is at fault.

Errors in the 30's indicate protocol violations and will require intervention by the designers of the PCC board, IF THE TRANSLATIONS ARE CORRECT. Should this be the case, contact Special Development Field Support in Denver at (303) 538-3477.

### PCC SPECIFIC FAULT CODES AND MEANINGS

SFC		MEANING
11 -	attempted read operation received no transfer ack.	outgoing fifo (not legal)
12 -	"	incoming fifo.
13 -	"	dpr address register (not legal) (this is physically possible but doesn't make sense).
14 -	"	DPR data.
15 -	"	status register.
16 -	"	ID chip.
17 -	"	incoming fifo underflow
18 - 20 -	unused	
21 -	attempted write operation received no transfer ack.	outgoing fifo.
22 -	"	incoming fifo (not legal)
23 -	"	dpr address register
24 -	"	dpr data.
25 -	"	status register.
26 -	"	id chip (lamp control)
27 -	"	outgoing fifo overflow
28 - 30	unused	
31 -	message transmission error - outgoing	bcc error
32 -	"	msn error
33 -	"	message length error
34 -	"	3-nak errors

35 -	"	3-enq errors
36 -	message transmission error - incoming	bcc error
37 -	"	msn error
38 -	"	message length error
39 -	"	3-nak errors
3a - 40	not used	
41 -	pcc self test found a problem with this device	outgoing fifo
42 -	"	incoming fifo
43 -	"	dual port ram
44 -	"	pcc data ram
45 -	"	pcc program rom
46 -	"	chap (80186 processor)
47 -	"	pcc self loop around failure
48 - 4f	unused	

- 50 - all msns currently busy
- 60 - CHAP sanity failure
- 61 - pcc failed to go into internal loop mode
- 62 - pcc flagged good message as having an error (sometimes seen when peripheral not terminating BTC protocol correctly)
- 63 - pcc returned bad echo of internal loop test message
- 64 - no ack received from peripheral in end-to-end loop test
- 65 - peripheral sent improper response to end-to-end loop message
- 66 - pcc failed to run requested self-test
- 67 - pcc failed to finish self-test in given amount of time
- 68 - internal loop not finished in given amount of time
- 69 - end-to-end test timed out waiting for responses
- 70 - Power Fail
- 71 - pcc detected loss of DTR signal from peripheral



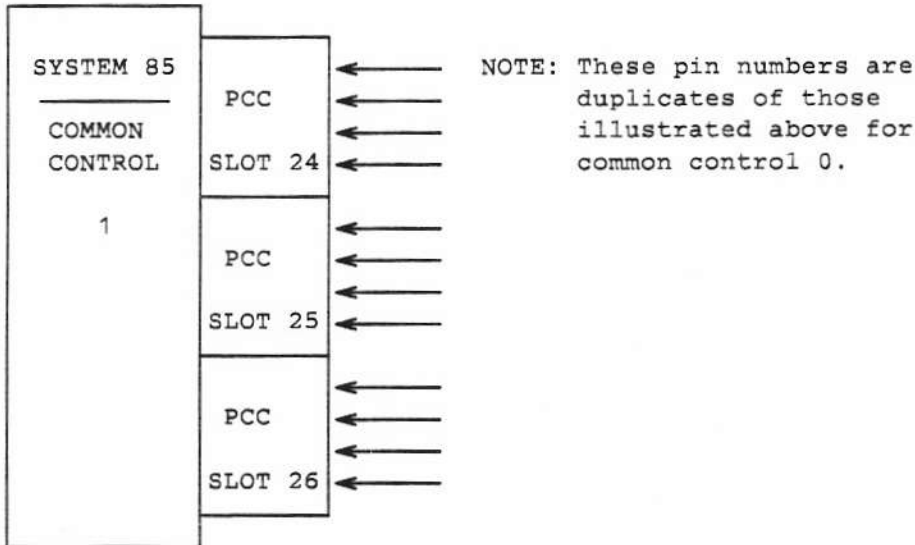
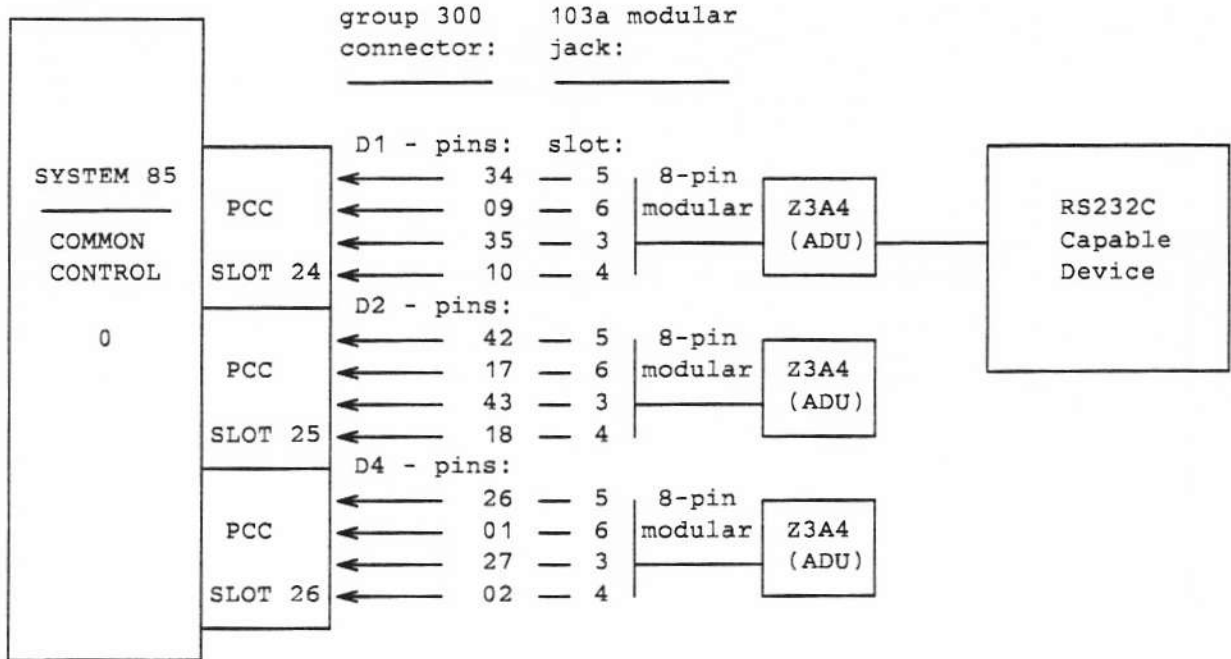

System 85 PCC to Peripheral Wiring Diagram