

*Bell Laboratories*

# RECORD

*June 1965*



The No. 1 Electronic Switching System

## Contents

PAGE

- 194 **Introduction** *W. A. Mac Nair*  
*Presenting an issue on the No. 1 Electronic Switching System and the technological and scientific climate in which it was conceived.*
- 196 **The Evolution of Telephone Switching** *W. Keister*  
*Seemingly a revolution in telephone systems, No. 1 ESS is actually squarely in the tradition of common control switching systems.*
- 204 **From Morris to Succasunna** *R. W. Ketchledge*  
*All the vast changes separating the Morris trial from the Succasunna office were made to enhance stored program control.*
- 210 **Features and Service** *J. J. Yostpille*  
*The stored program brings new services to Bell System customers and adds new flexibility to many traditional system features.*
- 214 **The Stored Program** *E. H. Siegel, Jr. and S. Silber*  
*Many functional programs, building blocks of the stored program, guide each step the system takes in processing calls and performing automatic maintenance.*
- 222 **The Control Unit** *A. H. Doblmaier*  
*The executive part of the system, it interprets instructions and data from the stores and generally keeps things running.*

## Editorial Board

G. C. Dacey, *Chairman* • W. M. Bacon • F. H. Blecher • W. A. Cornell  
A. E. Joel, Jr. • M. V. Mathews • H. G. Och • H. A. Stone

## Editorial Staff

B. E. Strasser, *Editor* • M. W. Nabut, *Managing Editor*  
G. L. Bromleigh, Jr., *Assistant Editor* • J. C. Smith, Jr., *Assistant Editor*  
• F. E. Piellusch, *Art Editor* • T. N. Pope, *Circulation Manager*

THE BELL LABORATORIES RECORD is published monthly by Bell Telephone Laboratories, Incorporated, 463 West Street, New York, N. Y. 10014, J. B. FISK, President; K. PRINCE, Secretary; and T. J. MONTIGEL, Treasurer. Subscription: \$2.00 per year; Foreign, \$2.95 per year. Checks should be made payable to Bell Laboratories Record and addressed to the Circulation Manager. Printed in U. S. A. © Bell Telephone Laboratories, Incorporated, 1965.

- 228     **Memory Devices**   *R. H. Meinken and L. W. Stammerjohn*  
*Two magnetic memory devices, the permanent magnet twistor and the ferrite sheet, store the operating intelligence of the system.*
- 236     **The Switching Network**   *A. Feiner*  
*A very flexible network, it is actually a cross between electromechanical and electronic, rather than fully electronic, techniques.*
- 241     **Mechanical Design**   *D. H. Wetherell*  
*Because its great flexibility stems from the stored program, No. 1 ESS needs fewer equipment options than any present system.*
- 246     **Power System and Ringing and Tone Plants**   *J. W. Osmun and J. R. Montana*  
*Solid state devices help simplify the power system and lead to the introduction of precision dial tones and call progress tones.*
- 251     **A New Approach to System Maintenance**   *R. L. Campbell and W. Thomis*  
*Automatic maintenance programs comprise over half the contents of the stored program and make No. 1 ESS a "do-it-yourself" machine.*
- 257     **Some Magnetic Materials**   *D. H. Wenny*  
*A new alloy was created whole cloth for the ferreed switch while two older ones got an entirely new magnetic dress for the twistor memory.*
- 262     **Semiconductor Devices**   *M. L. Embree and J. Sevick*  
*There are hundreds of thousands of transistors and diodes in the system, but a mere handful of basic types serve all system functions.*
- 268     **Testing the System**   *R. S. Cooper*  
*Before No. 1 ESS can be tried for the simplest kind of call, it must be tested and evaluated as a machine for executing programs.*
- 274     **Cut-Over at Succasunna**  
*On May 30, 1965 in Succasunna, New Jersey, 20 years of research and development were realized in the Bell System's first commercial electronic central office.*

**Cover**

*Devices on this month's cover are all components of the sole subject of this issue: The No. 1 Electronic Switching System. From the ferreed switch and the ferrite sheet (large and very small squares at the right) to the logic circuit (extreme left) and the ferrod sensor, all are unique devices in telephone switching. A part of the twistor memory occupies the center of the picture. This device holds the stored program, a set of instructions that shapes the system's responses to the requests of telephone customers.*

*(Cover painting by Paul Lehr.)*

# Electronic Switching

## *A Score of Years of Organized Attack*

It was inevitable that modern electronic technology would be applied to the switching machines of the telephone plant as it has to the transmission network. There is nothing casual or haphazard, however, in the form that electronic switching has taken in the Bell System nor in the date of its appearance as an operating office serving telephone customers. This program has been the largest sustained Bell System development effort toward a single goal ever undertaken by Bell Laboratories.

Prior to World War 11 various individuals had given thought to the possibility of an electronic switching system. Note that this was years before the transistor was invented or named. Immediately after the war, we organized a switching research effort to explore ways in which the evolving technology could be usefully applied to the problem of switching telephone calls. In 1953 an electronic switching organization was formed in the Development Area, hopefully looking toward a practical electronic switching telephone office. The 12 years since 1953 divide into two periods of a half dozen years each. The first culminated in the Morris, Illinois, experimental trial office; the second, in the Succasunna, New Jersey, office, giving commercial service. Thus, we come to the fruition of 20 years of Bell System organized effort directed toward an electronic switching system.

The final phase of the effort—the creation of the detailed design information, fabrication of the first models, tests of the hardware and software—was started in 1959. In the fall of that year, we set the goal of mid-1965 as the date for the first cutover. Bell Laboratories people engrossed in this project, view with some pride and much satisfaction the successful meeting of this schedule date.

The unique characteristics of No. 1 ESS and its solutions of technical problems will unfold as you read the articles in this issue of the RECORD. There

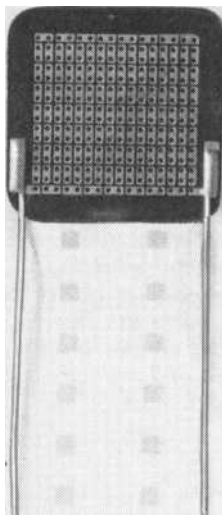

is an over-all uniqueness of the system to which your attention is directed for a moment. Compare No. 1 ESS with earlier switching systems.

The manual telephone switchboard was designed on the prior decision that switching would be accomplished by a human operator manipulating plugs, jacks, and keys. Step-by-step switching was based on the prior decision that switching would be accomplished with step-by-step switches controlled directly by the pulses generated as the customer dialed. Likewise, panel and crossbar switches were chosen as the central building blocks for those systems. In the case of electronic switching systems, no such prior decision was made. Compare one aspect of No. 101 ESS (*RECORD, February 1963*) and No.1 ESS. Both systems use much common type of equipment. But No. 101 ESS uses time division switches, and No. 1 ESS space division.

When work on electronic switching started, we understood the principles of common control and its huge advantages. We believed that electronic circuits would operate with such high speed that a single control would serve even a large office, and we saw the advantage in this, as distinct from a multimarker arrangement where competition arises between them. Further, we clearly recognized the usefulness of large memories with short access times. But the important decision to use memory to store the system logic evolved as the development work progressed.

There are two new and fundamental characteristics of electronic switching: the high speed electronic central control, and the use of memory to store the system logic which in turn determines, in detail, how the office will perform its functions.

And so, electronic switching came into being without a single piece of apparatus being prechosen as the preferred solution to any particular problem.

In the final phase of No. 1 ESS development,

our partnership with Western Electric has grown steadily broader and deeper as WE has produced, in hardware, Bell Laboratories' designs of apparatus and equipment, and delivered on tough schedules to meet close deadlines. The understanding, the give-and-take, and the real cooperation in this undertaking have been marvelous to behold.

While the big effort of the operating companies in the use of electronic switching offices to serve our customers better is yet to come, many operating company people have made individual contributions to the development and design effort. Others are preparing themselves to plan and operate No. 1 ESS offices in their territories. The significant contribution of the operating companies to date has been the coordinated planning to install No. 1 ESS offices throughout the country as fast as equipment is made available by the Western Electric Company.

There is no better example of the necessity for and the benefits derived from the association of the research and development people, the manufacturing and installation groups, and operating company people than this Bell System achievement of a common goal of better telephone service in timely fashion.

This post-war score of years has brought rapid progress in switching technology. Not the least is a kind of intellectual and organizational maturity which allows the designer to proceed in orderly fashion from the requirements to be met to the choice of system and apparatus to meet the stated objectives. Service to our customers will benefit greatly from this maturity.

W. A. Mac Nair  
*Vice President  
Transmission and Switching  
Development*

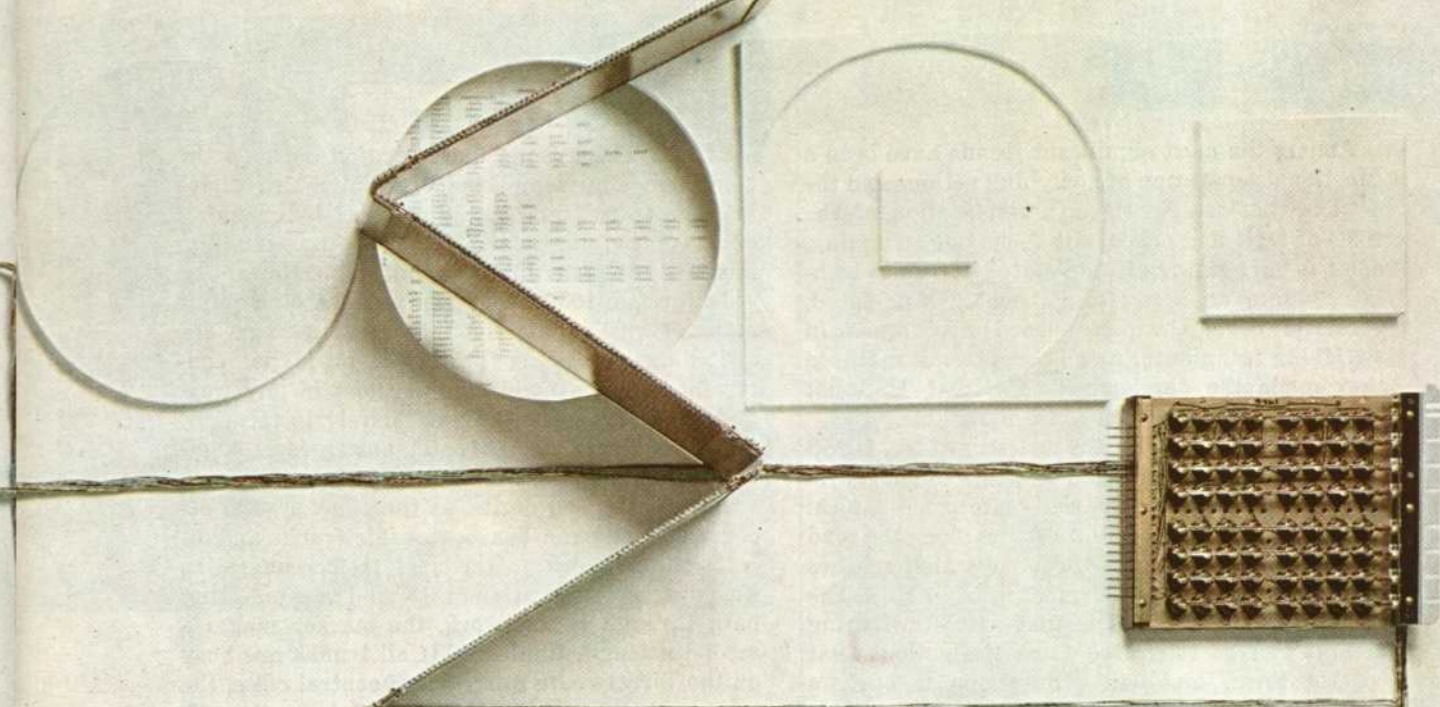
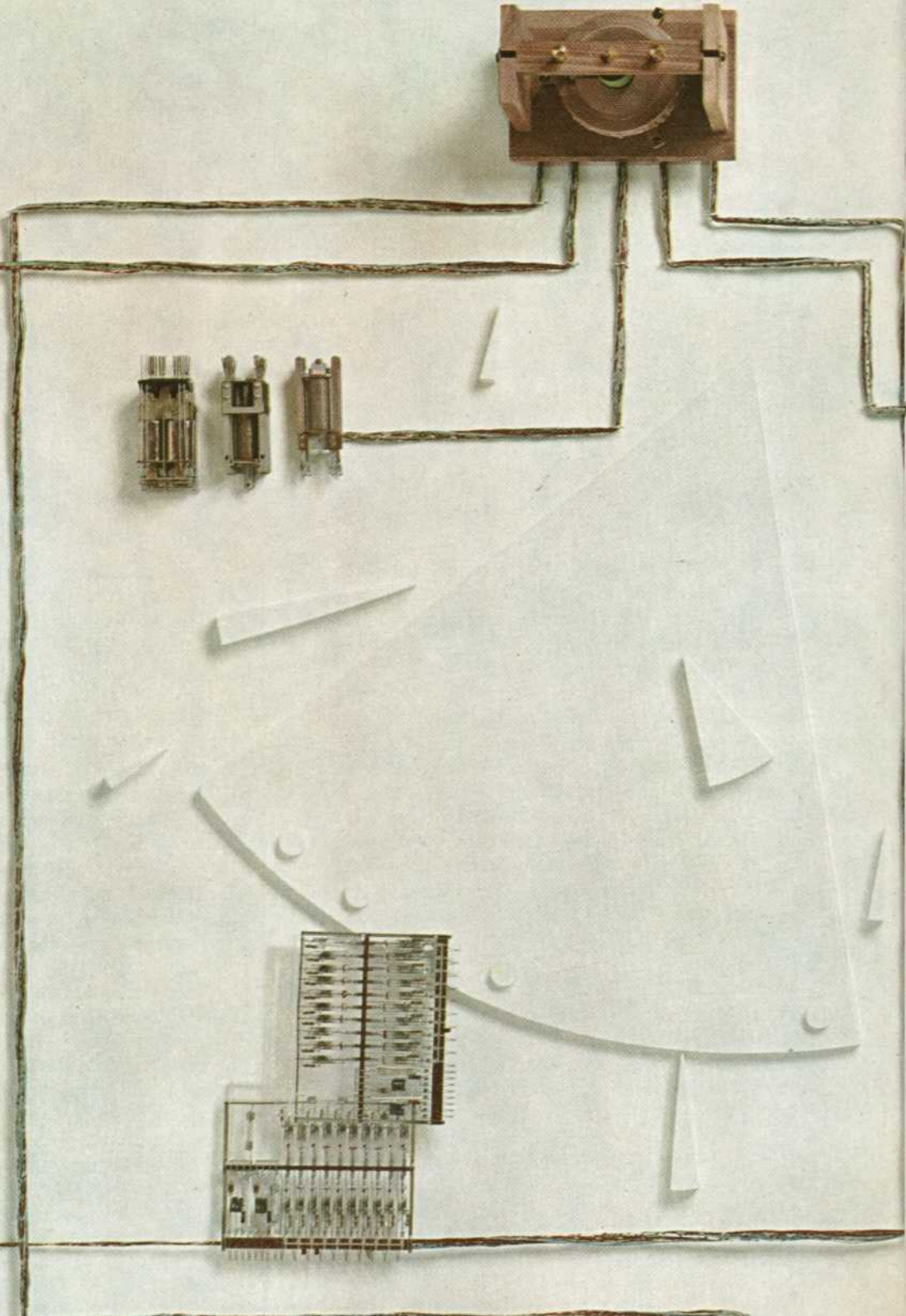
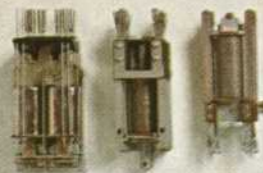
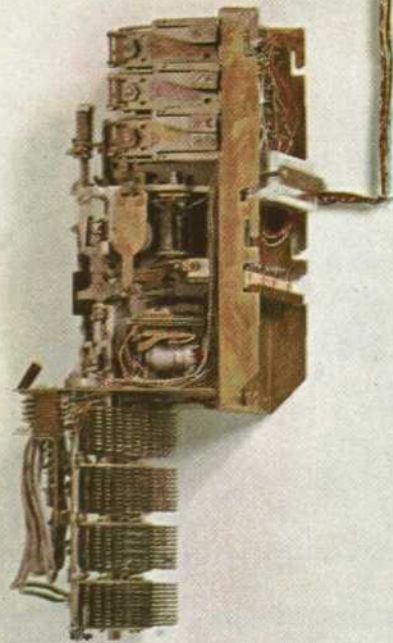

# The Evolution of Telephone Switching

W. Keister

**T**HE OPENING of THE No. 1 Electronic Switching System office at Succasunna, New Jersey in May, 1965 was the culmination of the largest single development project ever undertaken by Bell Laboratories for the Bell System. Because millions of man hours have been spent on this one development, it would appear, at first glance, that nothing less than a revolution in telephone switching has been in the making. In one sense it is a revolution, or at least the first stage of one: Electronic switching systems, in the next few decades, will replace all existing Bell System switching systems. But in a deeper sense, the No. 1 Electronic Switching System (henceforth ESS) is the product of years of accretion of experience along many lines in the evolution of telephone switching systems.

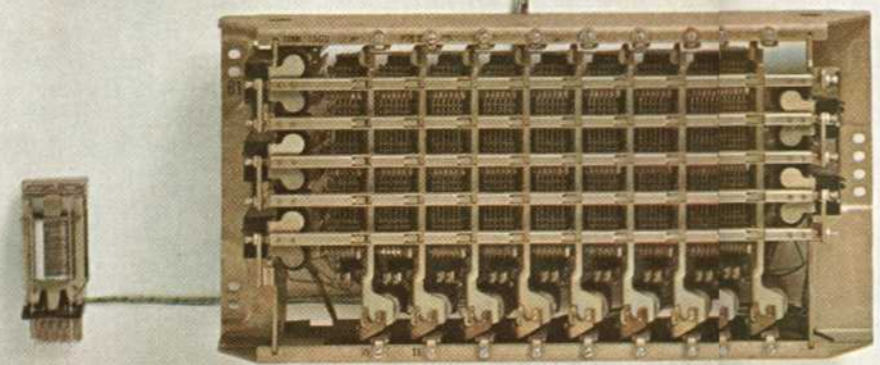
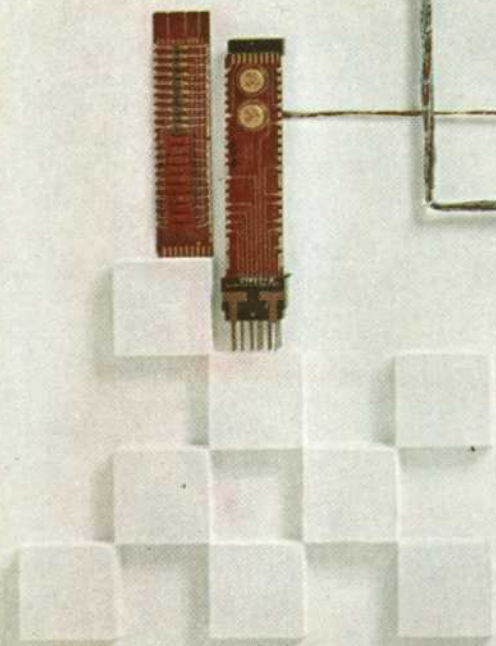

June 1965

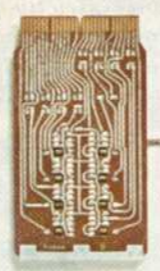

Among the most significant trends have been a functional separation of switching actions and the actions that control them, a clarification of the roles of logic and memory in telephone switching, and the burgeoning of solid state electronics technology into an array of extremely high-speed, versatile devices which opened new areas in switching techniques. As all these trends matured they made the development of No. 1 ESS not merely feasible, but in a sense inevitable.

Technically speaking, the ancestry of No. 1 ESS runs back through crossbar systems to panel systems. Both of these are strictly electromechanical systems, but both are definite stages along the road to common, or centralized, control which reaches its highest present development in No. 1 ESS. The basis of this technique is that actual switching actions can be separated from the actions that control them, and call connections through a switching network can be directed for many lines by one "common" group of control equipment. The control equipment routes a call through the network and is then released to act on other calls.

The concept was first tried in the panel system about 40 years ago. It was developed through early crossbar systems, and came to full maturity in the No. 5 crossbar system. In modern crossbar systems the network has no control function at all; control is the exclusive function of specialized equipment. However, in order to handle traffic demands effectively, the No. 5 crossbar system requires a number of duplicated groups of control equipment to serve one office. Electronic speeds allow No. 1 ESS to operate with only one control for an entire office.

Common control was not born with "automatic" switching systems. The first automatic system, the step-by-step system, is designed for direct control. Contact arms select terminals on the switch in direct response to the dialed digits. Because telephone numbers must correspond to the location of particular terminals, direct control allows little flexibility in the layout of the switching network. The technique is also rather profligate in its use of switching equipment—the amount of equipment tied up in completing one call under direct control is inherently capable of completing hundreds of calls in the same time.

The first elements of common control, units called registers, decoders, and senders, were introduced in the panel system. These units are never permanently associated with single lines or calls but are used in common by large groups of lines. Dialed digits are stored in the register and then converted by the decoder from decimal numbers to a nondecimal number system. The sender uses the converted numbers to control the panel

switches. There is no fixed relation between the converted digits and the original dialed digits and the translation can be changed by changing cross-connections in the decoder, thus providing flexibility in rearranging trunk connections.

In the late 1930s, common control took a major step forward in the No. 1 crossbar system. The switching network of this system is not constrained by the numbering system in any way, and hence it can be designed purely in terms of traffic requirements. This singular freedom stems from a new device, the "marker". In addition to translating dialed digits, as the panel system decoder does, the marker locates idle trunks and directs the network to them. If traffic congestion impedes the first attempt to find a connecting path through the network, the marker makes a second attempt. Similarly, if all trunks are busy on the direct route to a desired central office, the marker chooses an alternate route via another office. The philosophy behind these valuable features is that the marker can be made to examine the system to see if certain components are busy or idle. On the basis of its findings and the information represented by the dialed digits, it can then determine the most efficient way to make a desired connection.

Originating and terminating networks are separate in the No. 1 crossbar system. Each has its own marker to translate between telephone numbers (i.e. dialed digits) and control numbers. The terminating marker is assisted by a number group translator which can select a particular line from a group on an equipment frame in the central office. The line number on the equipment frame need not correspond to the telephone number, a factor that overcomes many constraints in the layout of the network and permits the network engineering to take account of the variation in the traffic load between individual customers.

A further improvement in these principles is embodied in the No. 5 crossbar system, first put in

*These diagrams show how the concept of common control and the concept of the roles played by logic and memory have evolved through the major switching systems from panel to No. 1 ESS. A major trend is the removal of any control function from the network. Notice how in the panel system sender links are part of the network, as they are in the No. 1 crossbar system. Also, these two systems have both terminating and originating networks. In No. 5 crossbar, and in No. 1 ESS, the networks have become strictly passive elements in terms of control. Notice how memory and logic in No. 1 ESS, are entirely discrete functions.*

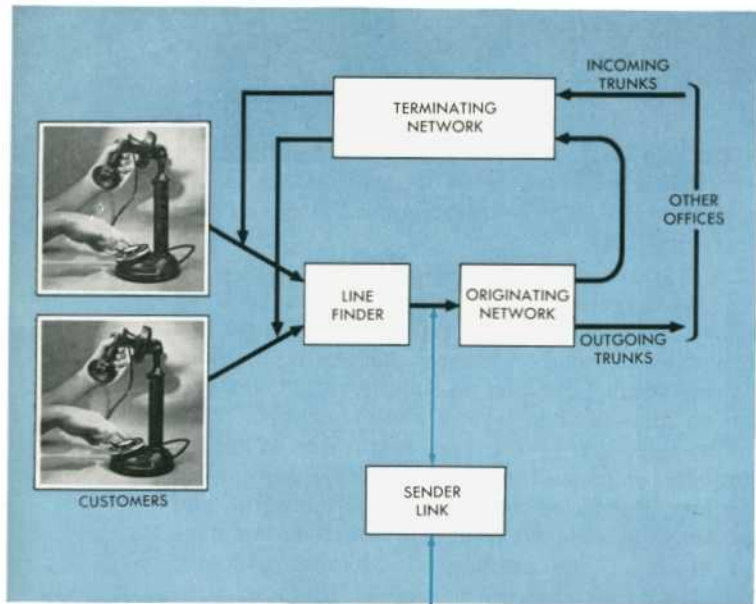

PANEL SYSTEM

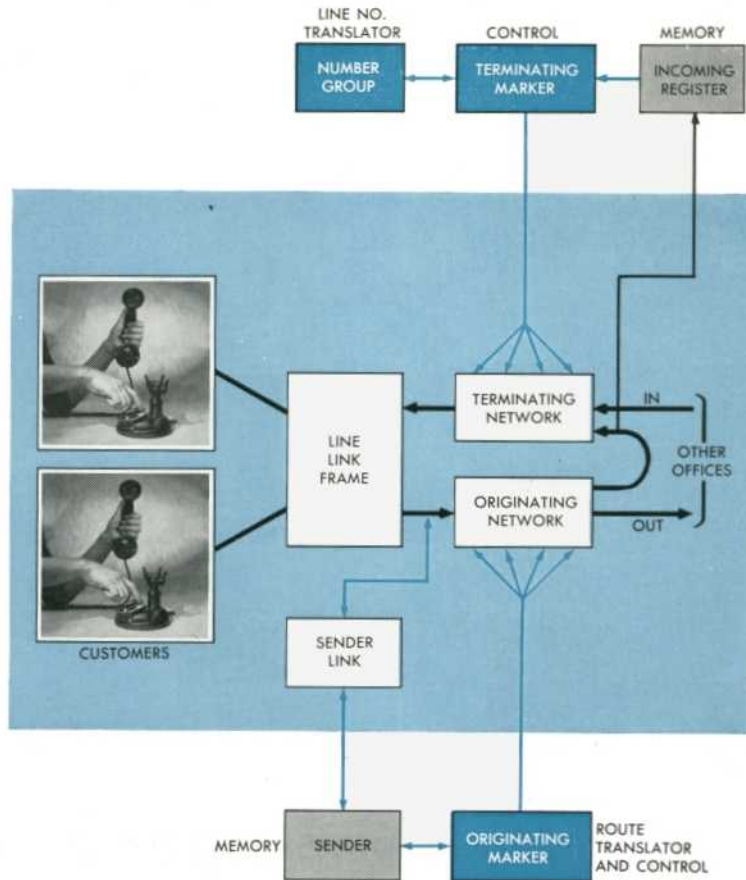

NO. 1 CROSSBAR SYSTEM

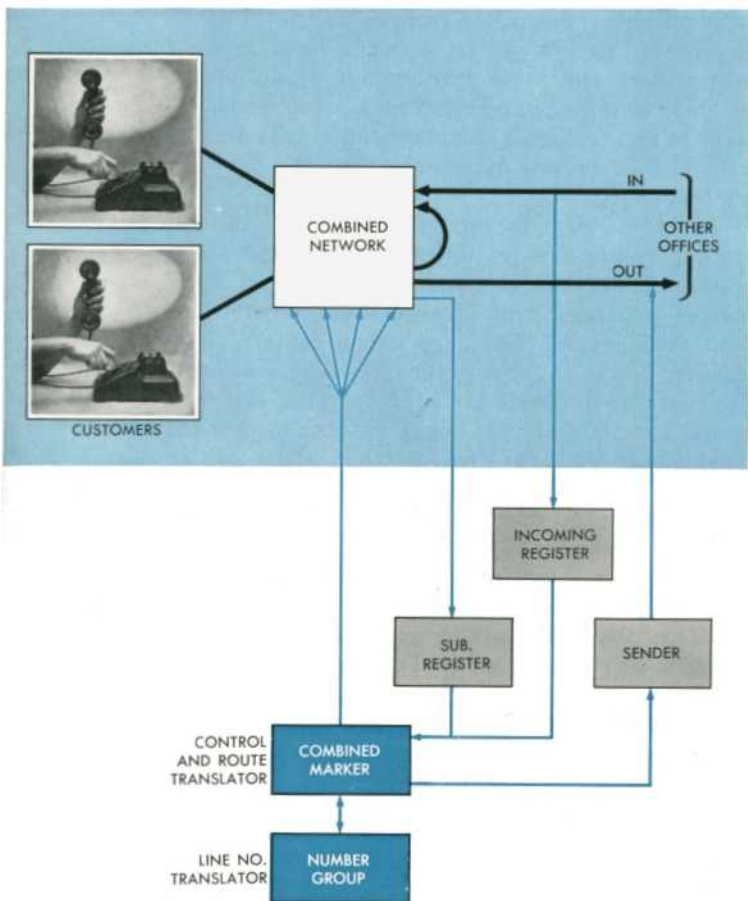

NO. 5 CROSSBAR SYSTEM

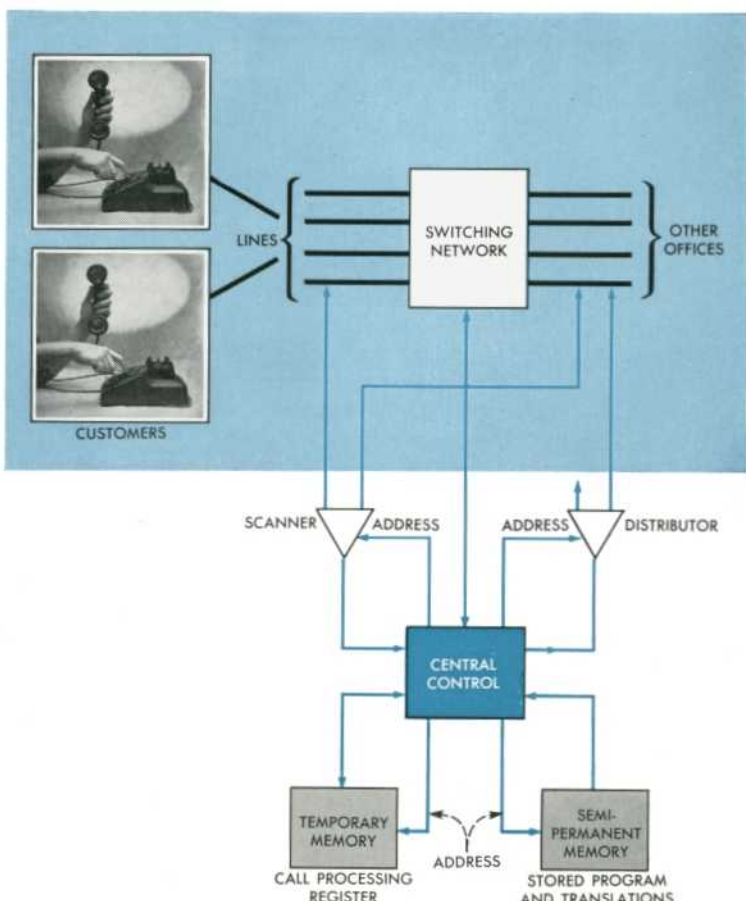

NO. 1 ESS



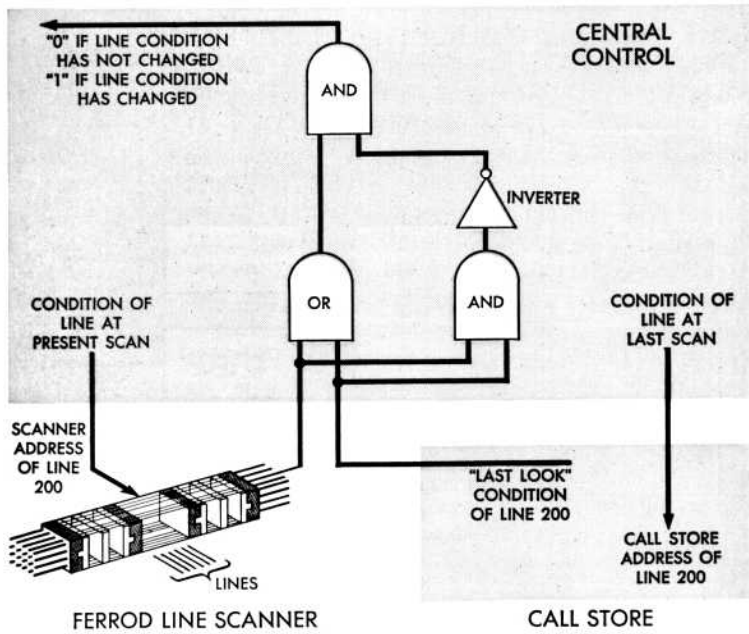

PRESENT LOOK	LAST LOOK	OUTPUT	MEANING
0	0	0	STATE UNCHANGED—OFF HOOK
0	1	1	STATE CHANGED—CALL START
1	1	0	STATE UNCHANGED—TALKING
1	0	1	STATE CHANGED—CALL END

A highly simplified way to apply logic circuits in line scanning is shown here. The central control directs the line scanner and the call store memory to report on the present and last states of line 200. The logic function to be performed is: if both states are 0, or if both states are 1, then the output signal should be a 0. (The table shows the output for various combinations of bits.) If the two states do not agree, however, then the output signal is a 1 to indicate that central control must take action on the line. If either the present or the last state, or both states, are 1, then the output of the OR gate is a 1. If both states are 1, the output of the lower AND gate is a 1 which the inverter changes to a 0. This is applied to the second input of the upper AND gate. Thus, the output of the combined circuit is 0 if both the present and last states are 1 or if both are 0.

service in 1947. A single network controlled by a single marker serves both originating and terminating traffic. The marker handles outgoing and incoming calls.

A number of parallel evolutionary trends in telephone system design emerged during these 40 years. We have been describing the major one, the evolution of common control systems themselves. It was accompanied by an equally significant evolution in switching devices and apparatus. Originally, the panel system used motor-driven shafts, clutches, cams, and innumerable other mechanical devices. But these were difficult to maintain, and as relays became more reliable they took the place of much of the mechanics. Crossbar systems, meanwhile, skirted the mechanical hazards with the relay-like crossbar switch and with control circuits that were almost exclusively relays.

During this time circuit designers began to look at their product in a wholly new light. They saw that they were not designing electrical circuits so much as logic circuits and that the intricate connective patterns between relay contacts needed to establish a talking path between telephones could be viewed as the stage-by-stage progression of the simple logical relations AND and OR. For example, consider a lamp plugged into a wall socket controlled by a wall switch. The lamp will not light unless both the lamp switch AND the wall switch are turned on. On the other hand, take the action of the dome light of an automobile which lights if one of the front doors OR the other is opened. Relays can be wired to open or close contacts in the same fashion and these simple logical relations can be repeated as often as necessary to form a highly complex system that decides complicated logical questions. (See the drawing on this page.)

All this was taking place within an all-encompassing change of the business and social environments that telephone systems served. Businesses expanded and decentralized; populations clustered around the large urban centers. This created demands not only for more telephone service, but for different kinds of services, and telephone system designers began to think of systems that would perform these services and could be adapted to new services as the need arose. Circuits which began to grow more sophisticated and more complex to meet the exigencies of the new types of services reached a point where the operating speed of relays became inadequate. Even crossbar systems, the last word in electromechanical systems, were reaching a practical limit in what they could be made to do. A new direction was needed.

Electronic switching techniques first came into their own in digital computers that operated suc-

cessfully in many weapons systems during the second World War. Studies made at Bell Laboratories soon after the war indicated that these high-speed electronic techniques could be pointing that new direction. But electronic technology, at that time, rested squarely on vacuum tubes which fell far short of the cost and reliability requirements of a practical telephone system. The last corner was turned with the invention of the transistor; an electronic system could now be built that would be competitive with electro-mechanical systems.

One dilemma remained: A system design usually is current for 10 to 15 years, its service life may be very much longer. New technical advances are made during a system's "design life," and social changes create new demands for features and services that the system is not equipped to handle. Often, the best way to effect these features and services is to design a new system to replace the old one, but the long service life imposes a more costly solution. Existing offices must be modernized and adapted to changing service requirements even while new installations of a more modern system are taking place. It often requires a greater effort to redesign an old system than to design a new one. And it often costs more to modify the old system for new features than to provide these features with a new system. Now, how do you design a system so flexible that it can be adapted to features that are not even foreseen at the time? Electronics had the answer—stored program operation.

The idea of a stored program system sprang from a close consideration of the roles of logic and memory, the twin operators that play such an important part in every telephone system. Memory is information, what to do. Logic is the decision-maker, how to do it. Memory knows what telephones to connect; logic decides what path to take between them. In the panel system, the sender provides memory and shares logic functions with the decoder. In crossbar systems, the two are more clearly defined; the senders and registers provide memory, the markers make the logical decisions.

In No. 1 ESS, the logic procedures for making telephone connections are written in the form of a stored program which is placed in a changeable memory. And therein lies the system's great flexibility. Logic was "written" in copper wire in the

*Wired logic. This intricate pattern of wires in a No. 5 crossbar system connects the many relays that perform the complex memory and logic functions required of the marker in directing telephone calls through the maze of a switching system.*

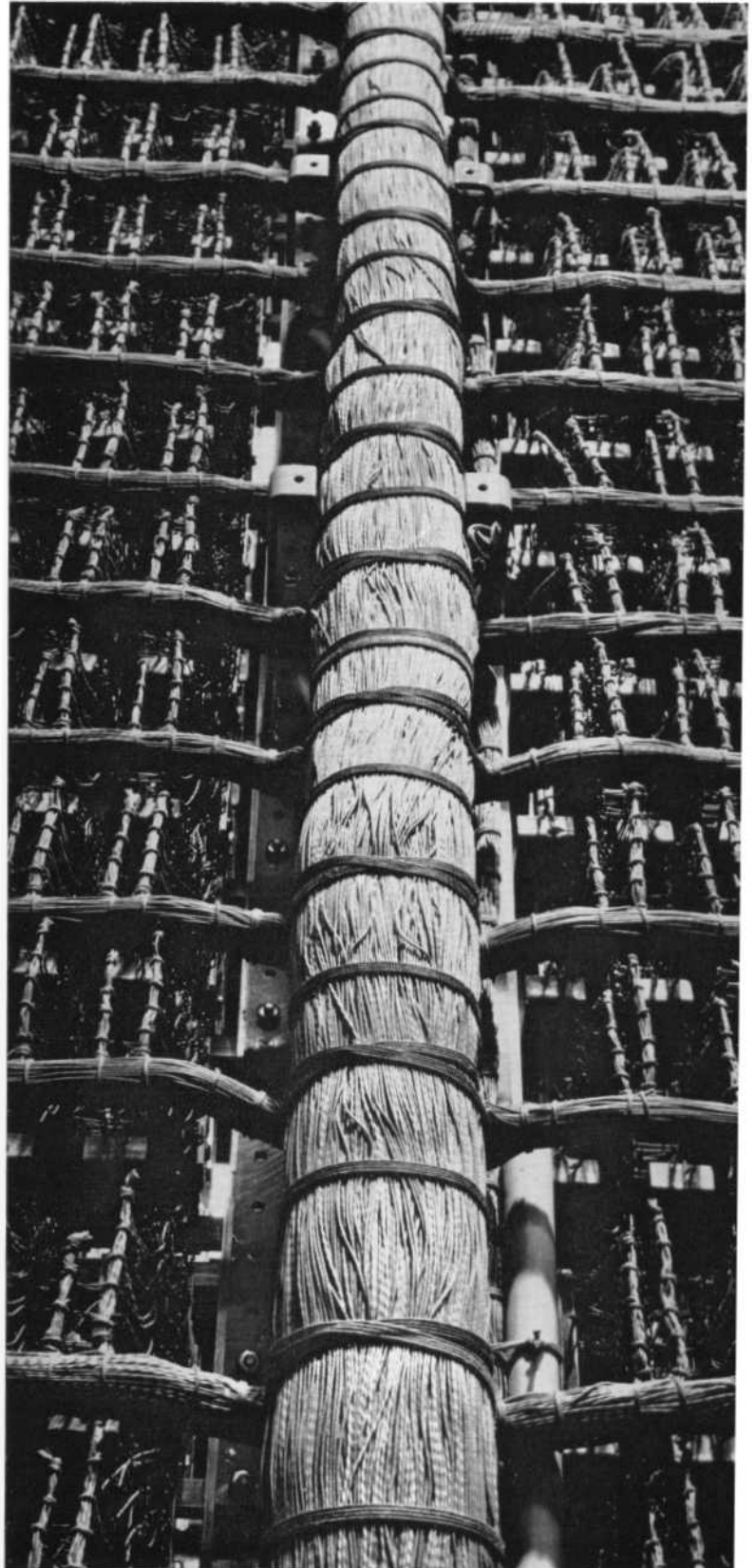

electromechanical systems, and each circuit was wired to perform one specific operation. To change the operation it was often necessary to rework and rewire circuits extensively. A No. 1 ESS program is contained on plug-in cards inserted in the memory. To change a logical operation, it is only necessary to change a memory card.

Formal logic is a discursive process, often making swift transitions between broad categories of argument. Programmed logic analyzes a call situation into discrete steps starting when a calling customer lifts his receiver and proceeding through a chain of control actions to establish a talking connection. To the customer, the connection seems to be made instantaneously; actually, the system deals with each step in turn. With considerable simplification, it works about like this

Every few milliseconds, the system checks, or scans, each customer's line and records its state-on-hook, off-hook, dialing, busy, in a talking connection, etc. The state detected at each scan is compared with the state recorded at the previous one. No action is taken if there is no change. When the system encounters a change of state—from on-hook to off-hook, for example—it consults the program to find what action is indicated. In this case, the off-hook state indicates that the customer wishes to place a call and the program directs that dial tone be sent to his line. While the customer dials, the program directs that his line is to be scanned at regular intervals, and each digit is recorded in turn but no further action is taken until he completes dialing.

After the system registers all the dialed digits, it again consults the program for the next step. For a regular station-to-station call, this step is to make connections through the switching network to the called telephone. That telephone may be busy or idle and the program is prepared for either eventuality. If the phone is busy it directs that busy tone be sent to the calling party. If idle, the called phone is rung and ringback tone is sent to the calling party.

When the call is answered, this state is registered and again the line is scanned at regular intervals but no action is taken until the parties hang up, at which time the program directs that connections be taken down. The whole process is characterized by a continuous interplay between the programmed logic and the temporary memory (a kind of electronic slate) that is associated with each customer's line. This memory records the instantaneous state of the line, and it registers dialed digits and other transitory information needed during the progress of a call. When a call is completed, the slate is wiped clean of information pertaining to it.

Programmed logic, in this description, wears the same discursive mantle that was attributed to formal logic. Actual program instructions, however, are not written in this way but are cast in machine language and its alphabet of binary symbols. The operations performed on the binary instructions by wired logic in the central control are the same as are used in most information processing machines. They consist of, for example, *shifting* information from one register to another where it may be *compared* with the contents of a third, while the difference is *stored* in another register, and *read out* in still another. A number of special instructions are highly relevant to call processing that would be valueless in conventional computing. For example, the busy and idle states of trunks can be represented as a binary "1" and a binary "0", respectively. If the state of a group of trunks is stored in a register, then an instruction to "find the rightmost zero" locates an idle trunk for a call in progress.

Translation and interpretation of the program instructions is handled by the wired logic of central control. This component of No. 1 ESS is the most far-reaching development of the concept of common control in present switching systems. It is concerned only with the basic information processing operations, not with the telephone switching logic which is all contained in the stored program. Logic and memory are thus completely separated from the switching network and the trunk equipment which are essentially passive parts of the system.

Only one central control processes telephone calls at any given time, while in a crossbar system it is common to furnish up to ten markers. For greater reliability, every No. 1 ESS office has a duplicate central control which is kept up to the moment on the progress of all calls in the system, but this is only for reliability. Electronic speeds, three or four orders of magnitude above the speed of electromechanical components, allow one central control to handle all calls in the system. It works on only one call at a time, but at such speed that it appears to handle all calls simultaneously.

Stored program control had its first trial with the Electronic Central Office in Morris, Illinois in 1960, where it was proved completely feasible. In fact, the stored program concept was the only thing that emerged from the trial unscathed. The components, the system organization, the organization of the program itself, all have been changed and improved for the Succasunna office of No. 1 ESS. In a sense, then, an evolutionary trend in electronic switching has been foreshadowed. In the next article, we will examine some significant details of that trend.

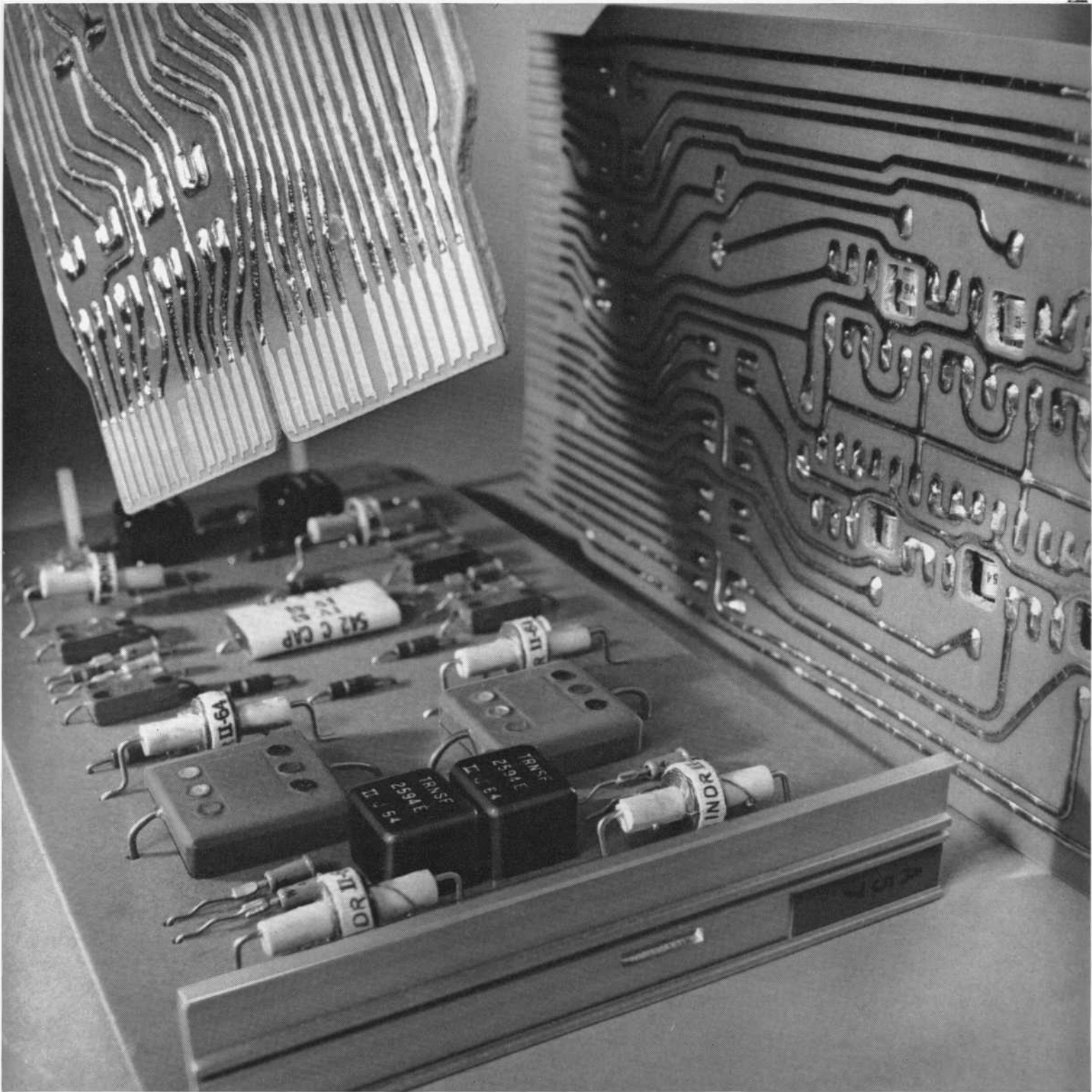

*Some of the circuit packs that perform the logical functions for the No. 1 ESS central control, shown here slightly larger than actual size. Central control is composed of thousands of these relatively simple logic circuits intricately connected to perform the necessary steps in processing the information central control acquires from other parts of the No. 1 ESS system.*

*A milestone in telephony, the Morris trial proved beyond doubt the validity of the stored program concept. But on the level of hardware nothing is left from Morris; Succasunna is a new office grown out of four years of intensive development.*

# From Morris to Succasunna

R. W. Ketchledge

THE ELECTRONIC CENTRAL OFFICE in Morris, Illinois was a pivotal point in the history of telephone switching. Turning back to electro-mechanical systems, we can see the Morris office as the highest point in the evolution of the concept of common control. Turning ahead to a switching future that is clearly committed to electronic techniques, we can view it as an archetype whose basic outlines may be shadowed in a number of future systems, but whose actual components already have been transformed into the much different components of No. 1 ESS. Although no components have survived the Morris office in their original form, No. 1 ESS embodies the basic idea of the trial system and the changes in components were made because they served the idea more effectively. That idea—stored program control—will become as familiar in the Bell System as the telephone itself.

It would have been a trivial application of electronic technology if the Morris office had been developed merely as an attempt to "modernize" telephone switching by substituting electronic techniques for electromechanical ones. The motive behind it was far broader, being nothing less than the desire to develop the most flexible telephone system that could be conceived. The

design of such a system would, clearly, have to take full advantage of the most reliable and versatile devices and techniques available. This conception inevitably led away from thinking of electronic circuits as a way to perform familiar functions faster, and into considering how their unique characteristics could be channeled into performing new kinds of functions for a new kind of system.

For example, from the point of view of a telephone customer a switching system that operates in tenths of seconds gives perfectly satisfactory service. Therefore, it would be pointless to control the switching network in millionths or even thousandths of a second if the object were only to make connections at astonishing speed. But suppose a cycle of time for the system were sliced into infinitesimally small pieces, or slots. In one slot the system could handle all network connections that had to be made, in the next slot it might diagnose its own internal condition, in the succeeding one it could direct an intricate new service. In the twelve seconds it takes the average person to dial a seven digit number, the system would perform millions upon millions of separate tasks involving a host of logical operations. Time, and the manner in which it is used,



*Morris, Illinois*

*Succasunna, New Jersey*

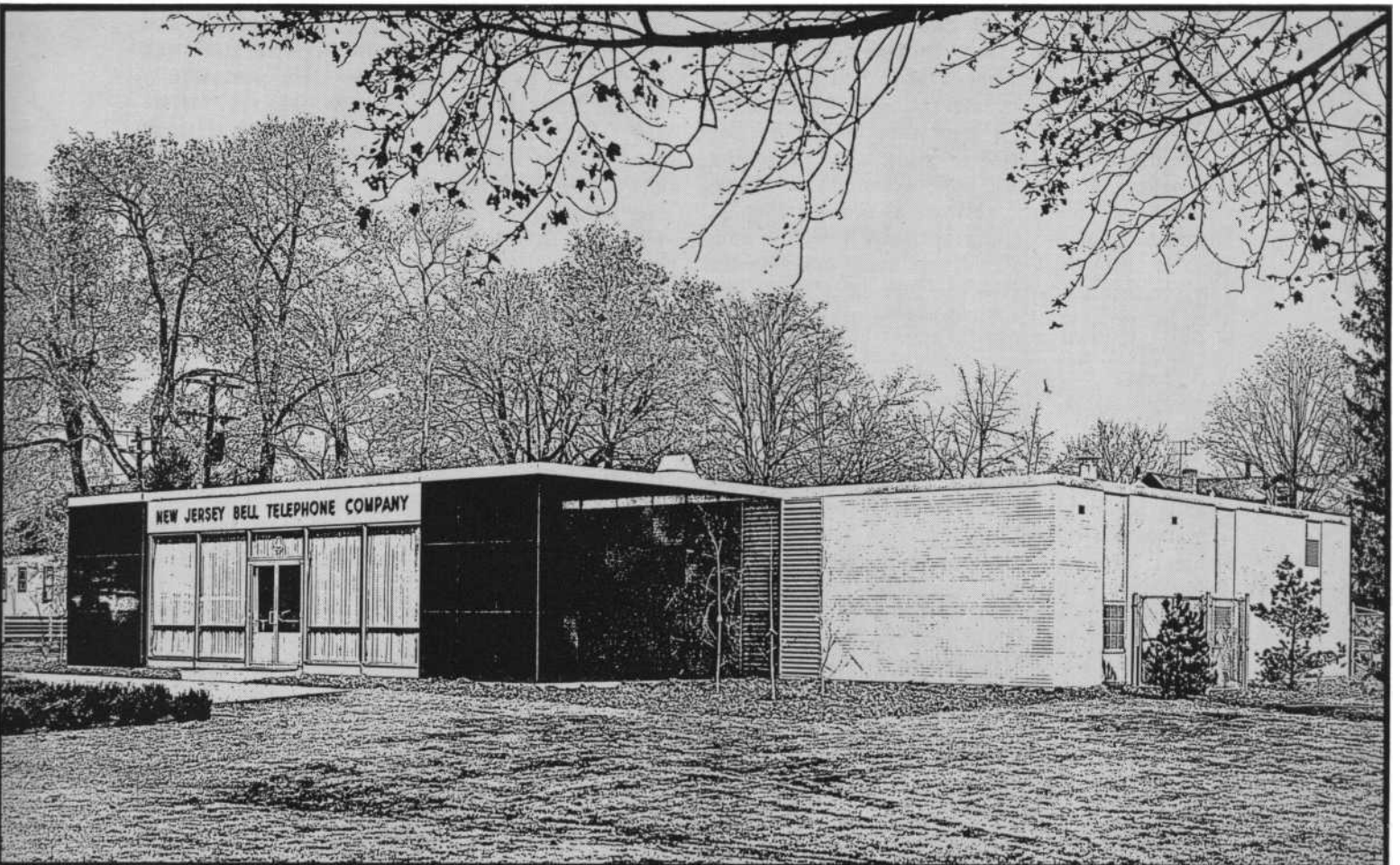

is thus one of the most intricate problems in the design of an electronic switching system.

It would not be difficult to design each component in the office to operate at the highest speed that can be achieved electronically, but it might be prohibitively expensive and somewhat pointless. A more exacting task is to define the range of speed needed in each of the various components, and then to design the office so that they all work synchronously. The memory devices, for example, must operate in microseconds because of the great number of instructions that must be read from the program and converted to control information that is sent to the switching network. The network itself, however, does not have to match the operating speed of the memories. If it operates in milliseconds, or even in fractions of seconds, there is only a remote possibility that it will be overpowered by traffic demands. The judicious use of buffers to hold information until the network is ready to act upon it helps to synchronize the very high speed memories and the slower network.

One of the most important lessons learned during the Morris trial was that the components of an electronic switching system should be designed to perform a particular function; speed of operation is only a characteristic of that function, it is not an end in itself. To illustrate this more explicitly, we will discuss, in turn, three examples of the changes made between Morris and Succasunna in which different decisions were made in terms of speed. In the first example, the memory devices, speed remained essentially the same but other considerations influenced the decision to develop a new type of device for Succasunna. The second example is the switching network; the network at Succasunna is inherently slower than the network at Morris. Finally, the method of switching between duplicate controls is an operation that was made much faster for Succasunna because the Morris trial showed that faster operation in this case was necessary for completely reliable service.

A heavy burden is placed on the system's memory devices. Their reliability cannot be overstressed, they must have large storage capacity in the smallest feasible volume, and information stored in them must be efficiently arranged and readily accessible. In the Morris office, the memories were electron beam devices; the semipermanent (or program store) memory was the flying spot store, and the temporary (or call store) memory was the barrier grid store. In the Succasunna office these have been replaced by solid-state devices; the program memory is the

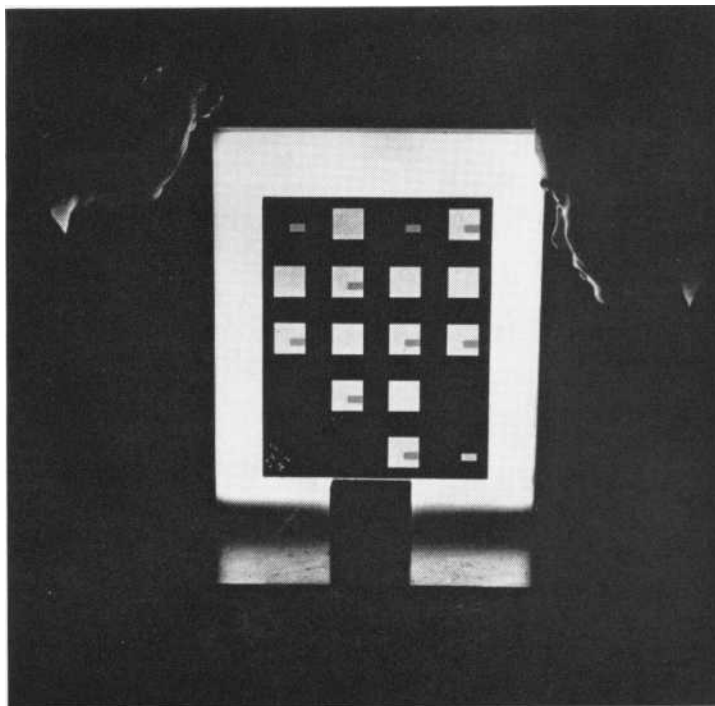

*The photographic plate used in the semipermanent memory in the Morris office is examined by R. W. Ketchledge (right) and C. A. Lovell. Each of the squares on the plate can hold 33,000 bits of information recorded as dots or absence of dots in particular locations. Four plates made up the semipermanent memory containing over 2 million bits of information.*

permanent magnet twistor, the temporary memory is the ferrite sheet.

The decision to develop the solid-state devices was not made lightly. The flying spot store and the barrier grid tube operated quite successfully in the Morris office, and although the ferrite sheet has clear advantages over the barrier grid tube in size and in accessibility of information, the flying spot store is quite competitive with the permanent magnet twistor in these characteristics. In all, the really clear area of choice was in the greater reliability of the solid-state devices.

When the design of the Morris central office began, solid-state technology could not yet offer the range of reliable devices needed in a telephone office. Therefore, sections of the Morris system, such as the switching network and the memory devices, were constructed with electron tubes even though the limitations of this technology were well known. Electron tubes were judged to be adequate for a trial that would last little more than one year, but in terms of the long life predicated for commercial telephone systems designers were already thinking ahead to the development of highly reliable solid-state devices. Thus, when after the Morris trial, the

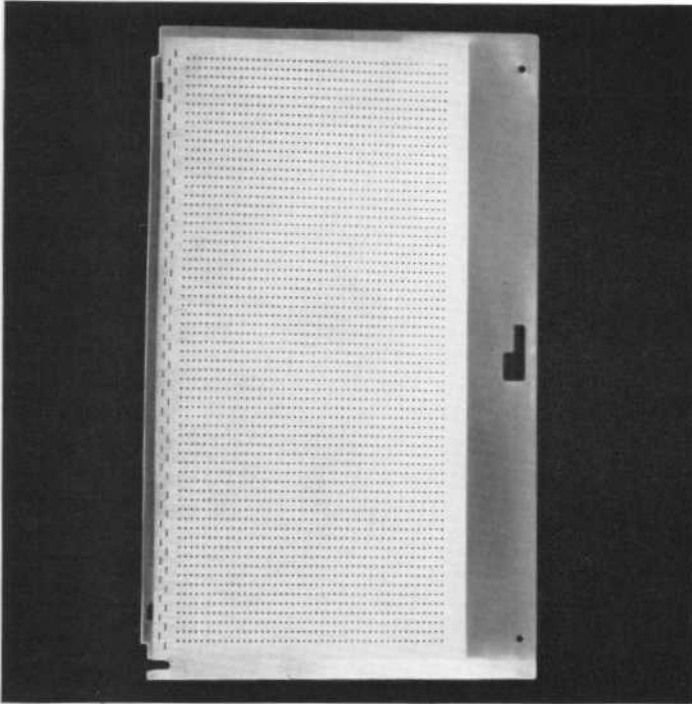

*This twistor card is inserted between folded stacks of twistor memory planes, the semipermanent memory of the Succasunna ESS. Each of the 2,816 vicalloy spots contains one bit of information, a zero if the spot is magnetized, a one if it is not. There are 128 cards in a twistor module and 16 modules in a twistor store. An ESS central office contains two to six stores.*

development of a solid-state memory was shown to be feasible, the decision was, in a sense, already made.

In other areas of comparison, however, the distinction between the flying spot store and the twistor was not at all clearly drawn. In the matter of capacity and physical size, for example, each has advantages and disadvantages. The capacity of the store used at Morris was under five million bits, but Morris was a small office serving only 435 lines. The smallest size planned for a No. 1 ESS office is about 3,000 lines and it has the capacity to grow to 65,000 lines. Vast amounts of memory are needed to control an office at its ultimate size.

Two proposals were made. One was for a flying spot store with a capacity of 25 million bits, the other for a permanent magnet twistor of 6 million bits. The permanent magnet twistor was chosen because it eliminated the problems inherent in the high voltages and hot cathodes of the electron tube device, it required less development (at the time it was proposed) than the flying spot store, and it offered the superior reliability of a fully solid-state memory.

In the competition between the temporary memory devices—the barrier grid store and the

ferrite sheet—the choice was clearer. The ferrite sheet memory can store a longer word than the barrier grid store, it is a more economical device, and again, it is a fully solid-state device.

The switching network of the Morris office represented the first study of fully electronic switching under conditions closely resembling commercial operation. From this point of view, the Morris network was a technical success, but it had certain drawbacks. One of the most serious was the inability of gas tubes to carry either high amplitude 20-cycle ringing signals or direct current from the telephone lines. In keeping with the inclination toward solid-state devices, a PNP diode that had many of the characteristics of gas tubes was considered for commercial application. However, a study of the operation of a remote line concentrator which employed the PNP diode showed that it had the same difficulty with ringing signals and direct current. DC switching through the concentrator was proposed and this led to the consideration of switching devices with metallic contacts. These can handle wideband signals including do signals, they have only negligible transmission losses, and they can handle higher power than either gas tubes or diodes. All these properties are even more valuable in switching network crosspoints than they are in a line concentrator. Thus, the invention of the ferreed crosspoint, the basic element in the No. 1 ESS switching network, grew out of these remote line concentrator studies.

The ferreed consists essentially of two magnetic reeds sealed in a glass envelope mounted between plates of a two-state magnetic alloy. The alloy can be very rapidly switched from one state to the other with a relatively short pulse of current, and it has the property of high remanence—it will remain magnetically saturated until another pulse switches it back to the first state. The switching can be done in milliseconds, as it actually is, or even in microseconds, so it is much faster than an ordinary electro-mechanical switch. It is, however, slower than switching performed by gas tubes or diodes, one reason being that the inertia of the reeds must be overcome each time the device is switched. However, as we have noted, the switching network is one place in the system where some speed could be traded for other important characteristics, so the ferreed crosspoint switch was developed for No. 1 ESS.

Control techniques of a ferreed switch are quite different from those of diodes and gas tubes and the new techniques necessitated changes in the



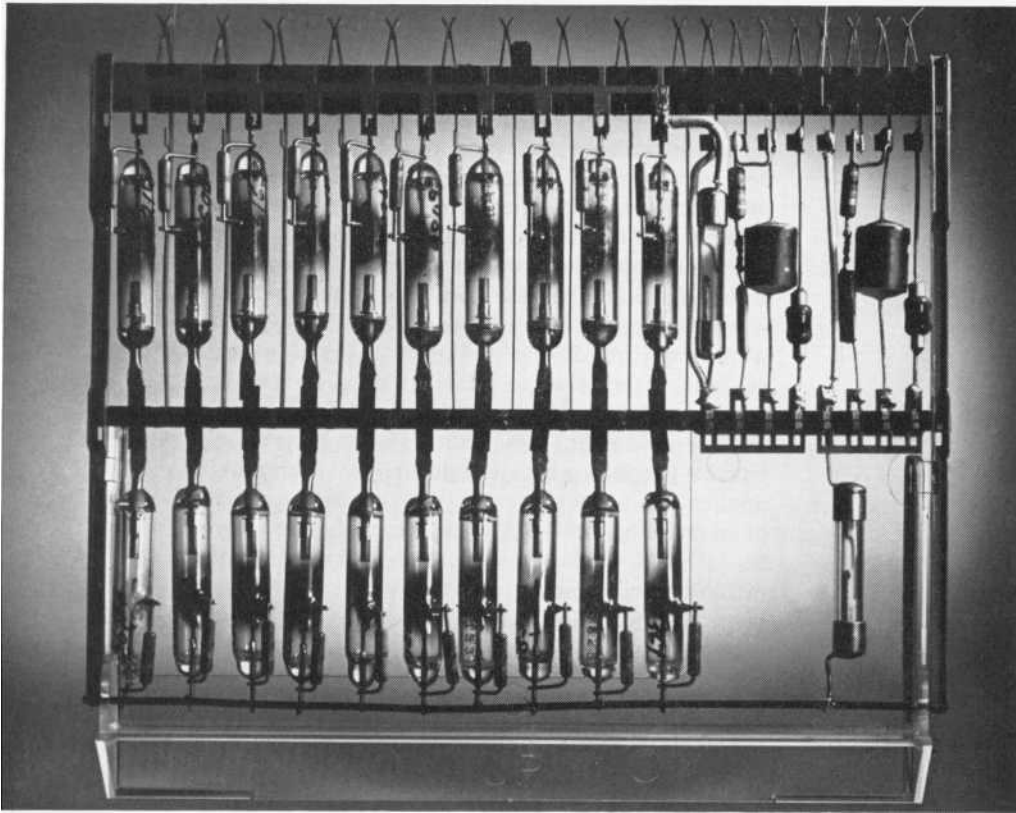

*The gas tubes used in the switching network at Morris. The system contained more than 23,000 of these tubes which operated successfully throughout the year's trial.*

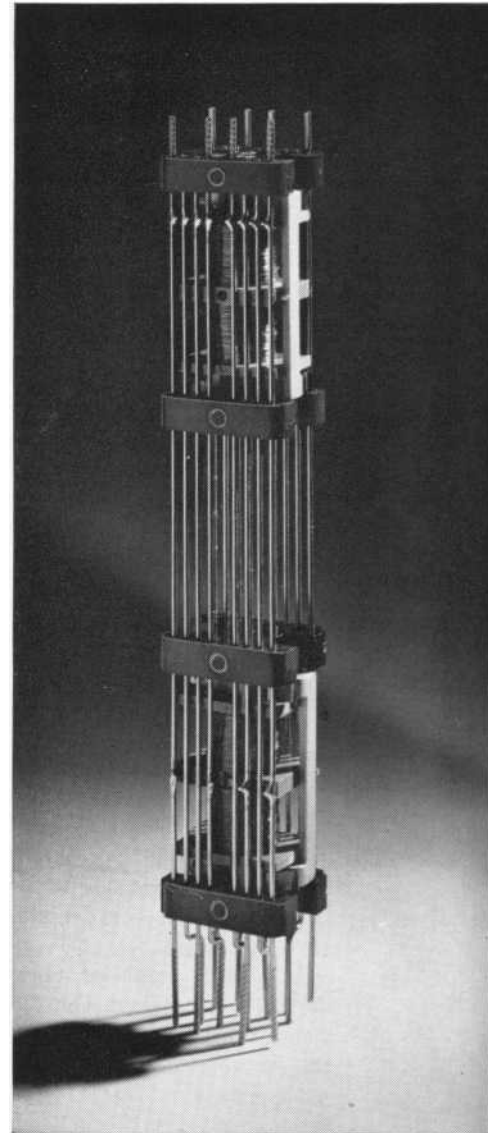

*The ferrod, a magnetic current sensing device, is the basic element of ESS line scanners. Each telephone line is connected to a ferrod sensor. Ferrods are arranged in 64 rows, 16 to a row. Every one tenth of a second, central control instructs the scanner to check all the ferrods in a single row simultaneously. The device is introduced at Succasunna.*

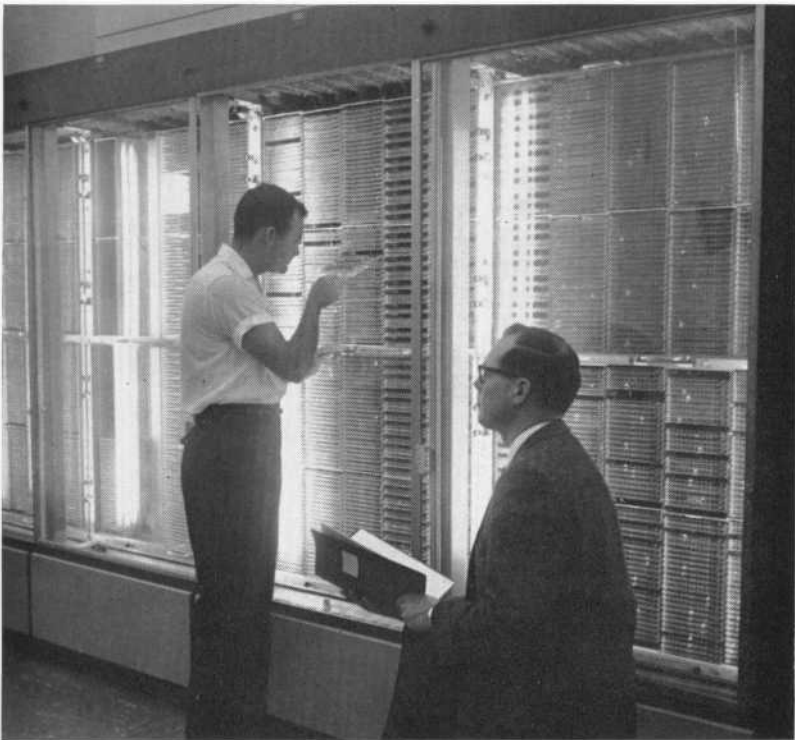

*Overall view of part of the switching network at Morris. The dots of light at right are tubes that were being used in talking connections when this picture was taken.*

overall system and development of new control devices. The control circuits for the first ferreed were composed of semiconductors, but as the switch was developed it became apparent that the operating speed of semiconductors, in this case, is gratuitous. Therefore, the diodes were replaced with relays which reduced the cost of the control network.

A new control device grew out of the problem of line scanning. The ferreed gives the switching network the ability to extend the metallic wire path from a customer's telephone to any part of the central office. To start this action, the system must sense the presence or absence of current in the customer's line which indicates if the telephone is off-hook or on-hook. A fast scanning device is needed to examine all the lines in the office at frequent intervals so that a customer does not wait for service. Furthermore, for transmission reasons the line must remain balanced and undisturbed by the scanning action.

The ferrod—actually a saturable core transformer—grew out of these requirements. It consists of a rectangular ferrite stick surrounded by two solenoid windings connected in a balanced arrangement on each side of a customer's line. Two single turn loops pass through two small holes in the center of the stick. If the customer's telephone receiver is on-hook there is no current flow in the line, and a pulse applied to one winding produces a corresponding pulse in the other. However, if the receiver is taken off the hook, current flows in the line and saturates the ferrite stick. Thus, when the pulse is applied, the saturation blocks the output pulse and the telephone is known to be off-hook.

As the first article in this issue has pointed out, No. 1 ESS has gone about as far as it is possible to go with common control: Only one group of control circuits in the system is used to give telephone service at any time. However, to guard against loss of service in the event of a failure, each office has twin control systems. Both keep up to the minute on the progress of all calls through the office because each actually processes every call, although only one actually controls the switching network. If the active control should develop trouble, the standby is immediately switched in to take its place. The switching must be done fast enough to keep from losing any calls.

Relays performed the switching in the Morris office. They required tens of milliseconds to operate and at this speed they occasionally caused a dial pulse to be lost if a customer was dialing during the changeover. To raise the switching speed to the range required to avoid the loss of

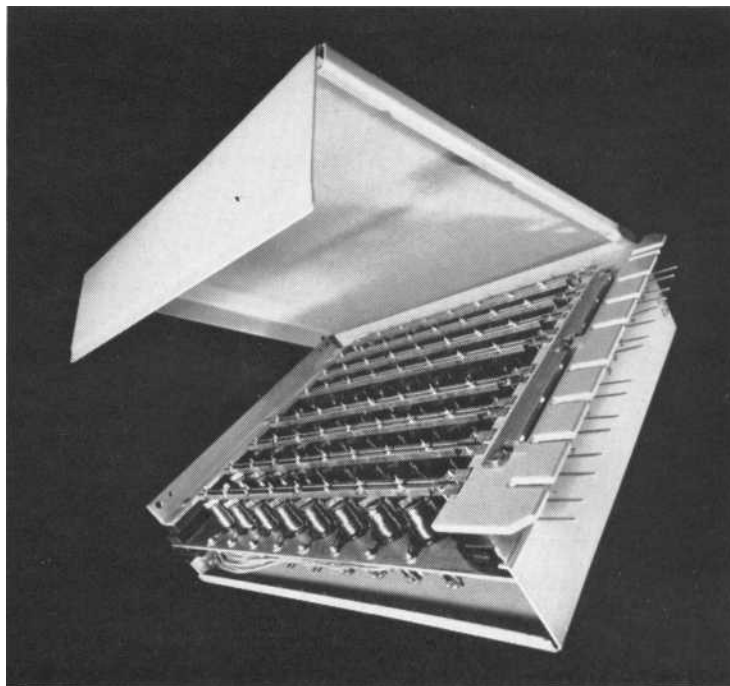

*The basic 8-by-8 crosspoint array of ferreed switches that make up the switching network at Succasunna. To connect two customer's lines for a telephone call eight of the individual ferreeds in the array close in a specified pattern and they remain closed without any holding power.*

any calls in progress, the No. 1 ESS bus system was devised.

This system is simply a set of high-speed data channels (actually, for reliability, each office has a duplicate set) that permanently interconnect all equipment units in an office. Electronic gates control the flow of data, selecting the particular channel over which any equipment unit can send or receive. The gate settings can be changed in microseconds in order to establish a new pattern of information flow between the units. The buses are easily extended to new equipment that may be added as the office grows.

There is no question that electronic switching has come of age. Indeed, the myriad changes between Morris and Succasunna almost justify that this article be subtitled *The Evolution of Electronic Switching*. In Morris, electronic techniques were used as widely as possible to explore all their potential. The experience showed where the techniques were superior to electromechanical techniques, where they were inadequate, and where they just were not necessary. In the following articles we will turn from the ancestry and history of electronic systems to a direct consideration of No. 1 ESS itself.

*Although No. 1 ESS brings many new features and services to telephone customers, it must also compete with existing systems. Stored program control puts No. 1 ESS ahead of today's systems in many ways by expanding established services and giving them a new versatility.*

# Features and Services

J. J. Yostpille

FROM THE PRINCIPLES of telephony discovered in a Boston laboratory 90 years ago, to the investigations leading to the development of No. 1 ESS, the progress of the communications industry has been linked tightly to research. We have seen how various streams of research came together in No. 1 ESS to produce, at their confluence, a switching system that embodies a major conceptual advance in telephony-stored program operation. What are the practical results?

To the Bell System customer, No. 1 ESS may mean a whole new range of optional services depending on the results of customer trials. With these services he can reach a 7- or 10-digit number by dialing only 2 or 3 digits, he can arrange a telephone conference simply by dialing two or three other conferees, he can have calls routed from his own telephone to any other nearby telephone by dialing a short code. To the Telephone Operating Company, these and other services we will discuss in this article are commercial assets, but they are only the public face of No. 1 ESS. Behind that there are the hard practical requirements that a new telephone system must be economically competitive with existing ones, and it should be easy to maintain and to administer. No. 1 ESS has several things in its favor along these lines and each reflects the versatility of stored program operation for a telephone system.

One thing in the system's economic favor is that new services can be added by changing program cards, a far more economical process than the extensive rewiring and equipment modifications that accompany most changes in electromechanical offices. Another asset is that No. 1 ESS can serve more customers than any other system, a capabil-

ity it derives primarily from the high-speed central control which is directed by the program.

Maintenance and administration are more easily performed than on any other system. Guided by maintenance programs, the system continually checks its own internal condition and, over a teletypewriter, reports any discovered faults and their locations. Most maintenance jobs are thereby reduced to a matter of replacing faulty circuit packages. Administrative personnel can communicate with the machine over the teletypewriter and instruct it to change, cancel, or add to information in its memory that is pertinent to growth or additions to an office.

In all these features, the program can be viewed as the moderator in a dialogue between the customer and the system, and between maintenance or administrative people and the system. Each special service, for example, is delineated in a sequence of actions in the program. A customer starts the sequence by dialing a 2- or 3-digit code which is referred to the program by central control. The code is recognized as the signal for a special routine and central control, directed by the program, sets it in motion. Some routines are started by a momentary "flash" of the switchhook instead of a code. Five optional services are being tried on an experimental basis by 200 selected customers in the Succasunna office of No. 1 ESS. They are called Abbreviated Dialing, Dial Conference, Add-on, Automatic Transfer, and Preset Automatic Transfer.

Abbreviated Dialing replaces a 7- or 10-digit number usually with a 2 or 3-digit code. A customer with an ordinary dial telephone can have a list of eight abbreviated 3-digit codes to represent

eight numbers he calls frequently, or he can have a list of 30 numbers that require 4-digit codes. TOUCH-TONES telephones will have an extra (eleventh) button to replace the first 2 digits of each code which are the fixed prefix "11".

Dial Conference lets the customer control his own conference hookup without the services of an operator. He dials a code that results in the connection of his line to a 4-port conference trunk, then dials two or three telephone numbers which are connected to the trunk in turn.

Add-on, a modified form of conferencing, lets a customer turn a 2-way conversation into a 3-way conference. A momentary "flash" of the switch-hook brings dial tone and the customer dials the code digit "2" and the number he wishes to "add-on". His first call is automatically held and all three lines are connected in a conference trunk.

Automatic Transfer and Preset Automatic Transfer, variations on one theme, permit a customer who is visiting friends for the evening, or making a business call, to reroute incoming calls from his telephone to his host's or his colleague's telephone if it is in the same local area. For Automatic Transfer, the customer dials a code and the number he wishes calls transferred to. For Preset Automatic Transfer, he has a list of eight numbers, each represented by an abbreviated code. To transfer calls to any number on the list, he merely dials the appropriate code.

These are only a few samples of the many services No. 1 ESS can provide. Their execution is based on a continuous exchange of information between the switching network and central control, and between central control and the temporary and semipermanent memories. For example, abbreviated codes are not contractions of the actual telephone numbers, but consist of the 2-digit prefix "11", and any third digit. When the customer dials the code, it is stored in the temporary memory. (See the drawing on page 213.) Central control is then directed by the program to examine and interpret the code. The program, recognizes the prefix followed by the third digit as an Abbreviated Dialing code. Alternatively, it recognizes the multifrequency TOUCH-TONE signal of the eleventh button as equivalent to the prefix. A list stored in the memory translates between the code and the wanted telephone number. Central control takes the full number from the semipermanent (program store) memory, transfers it to the temporary (call store) memory as if the customer had dialed it, and directs the system to "dial" or outpulse the complete number.

In the case of transfer service, a record of the customer's transfer request is stored in the tem-



*The master control center at the Succasunna No. 1 ESS office. Controls and lamps on the panels at the far right are used for various maintenance and administrative functions. The teletypewriter supplements the panel controls. The tape reels at the left are used for automatic message accounting recordings.*

porary memory together with the number he wishes calls transferred to. The system refers to the temporary memory when a call comes in to the customer's number, and instead of completing a call there it reroutes it to the transfer number.

If a customer with Add-on flashes his switch-hook for a period less than 1.5 seconds while he is in a talking connection the system interprets it as a request for this service. Central control, under direction of the program, then connects the customer who flashed to a dial pulse receiver and holds the second party. The customer then dials the party he wishes to add and the system establishes a 3-way connection in the network.

These special services can be arranged in electromechanical offices by adding special equipment which, in some cases, may be electronic. Possibly an even better measure of the versatility of stored program operation lies in the flexibility it provides for some of the most commonplace features of a telephone switching system. Take the example of a hunting group. This is a familiar service found in most business and PBX systems in which an incoming call that encounters a busy line is routed to another line, then to another if the second is busy, and so on until a connection is made or all lines in the group are found busy.

In electromechanical systems, this is a wired equipment function and, therefore, it has certain limitations. A hunting group is usually restricted to certain blocks of lines and the hunting sequence is arranged consecutively. In other words, if the first telephone number in the group, or block, is number 1111, the second is number 1112, the third

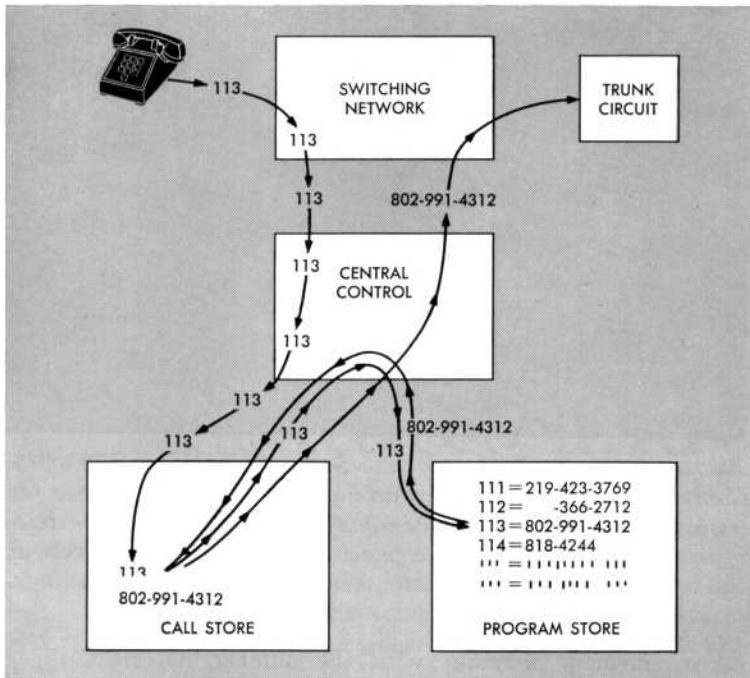

*Any telephone call through No. 1 ESS involves a constant exchange of information between central control and the two memory blocks. Abbreviated dialing is illustrated here. The abbreviated number "113" dialed by the customer is stored in the call store memory. Central control then refers the number to the program memory which checks it against a list of eight possible numbers. The full number represented by "113" (it may be 7 or 10 digits) is transferred to the call store memory where it replaces the abbreviated number. Finally, the complete number is sent through the switching network to outgoing trunks to the distant office just as if the customer had dialed it in its entirety.*

number 1113, etc. A call to number 1111 can hunt through the whole group if necessary, but a call to number 1113 can only hunt to higher numbers, it can not hunt back to the lower ones.

In No. 1 ESS, the lines in a group and the order of hunting are stored in the memory, the lines are not associated through wiring. A call can be made to hunt through a group of arbitrary lines in any desired sequence. Alternatively, if the call is not completed in the first group it can be shifted to another and made to hunt through that. Customers can operate control keys in their offices which will cause the system to hunt in these patterns, or not hunt at all when that is desired.

Another example of how No. 1 ESS imparts new versatility to an established feature is classes of service. This tested and indispensable feature permits different treatment on PBX lines. Some can be limited to local calls, others to toll calls within a limited area-even to a specified exchange with-

in an area-and still others may be unrestricted. The feature is also used to route and charge calls on various kinds of customer service. Again, wired equipment puts certain bounds on this feature for electromechanical offices. In No. 5 cross-bar offices, for instance, there can be only about 100 classes of service. No. 1 ESS increases it tenfold; a total of 1024 classes of service can be stored in the memory. The large number of classes will be particularly useful in offices that elect large numbers of features and services. Each special service can be given a class of service and then allowed on some lines and denied to others.

Features and services can be added to No. 1 ESS offices almost without limit. They seldom curtail the system's normal call-processing ability which is affected mainly by traffic conditions. In any given traffic situation, however, No. 1 ESS can serve more customers than any other switching system. The upper limits on No. 1 ESS are 65,000 lines and 100,000 telephone numbers-party lines account for the discrepancy. In an area with average calling rates-a suburban community like Succasunna, for instance-an office can serve the maximum number of lines. But in an area with a high calling rate, like Washington, D.C., No. 1 ESS may reach its maximum call-carrying capacity with only about 30,000 lines. In this case, the calling rate determines the size of the office.

A rare event that does act to degrade service is an extreme overload on the system. The cause is usually external to the switching system-floods or hurricanes may damage the outside plant, for example, severely reducing the number of trunks available to an office and causing overloads. At such times, electromechanical offices may be forced to invoke line-load control, completely cutting off service for all but essential lines such as fire departments, police, and hospitals. Nonessential lines can only receive calls. Manually operated switches govern the action. When they are thrown, all nonessential lines associated with them are denied originating service and the action is revoked only when the switches are reset.

Stored program control, on the other hand, can deal with degrees of overload, continually reorganizing and readjusting the system so that service continues at the most efficient level despite severe changes in internal or external circumstances. The program recognizes a certain hierarchy in the jobs the system must do and acts always to maintain it by periodically measuring the efficiency of service against a certain standard. The standard includes such things as permissible delay in returning dial tone, the number of calls blocked in the switching network, and other

indications of normal or subnormal service. If service falls below an acceptable standard, routine maintenance and similar low priority jobs are dropped. Then, if further adjustment is necessary, processing of new calls is deferred until calls in progress are completely processed. Thus, line-load control is initiated by degrees. Essential lines (indicated by class of service) receive priority, but the system denies service to nonessential lines only at moments of extreme overload. Thus, when line load control must be put into force, No. 1 ESS still serves all essential calls and as many others as it can. Service is not flatly denied to any line, and when the overload subsides, the system automatically returns to normal.

All these features and services are delineated in the program. Still, these things and their ramifications require only about half the program content. The other half is concerned with maintenance, for it is a simple but undeniable fact that the most important task of a telephone switching system is to keep running. A computer may break down in the middle of a problem and the problem may be rerun because all the vital data remains in the computer. But a switching system breakdown is disastrous because requests for service are irrevocably lost. Furthermore, it is a fair rule that the more complex a machine is, the more difficult it is to maintain, and No. 1 ESS is an extremely complex electronic machine. Yet we have said that No. 1 ESS is easier to maintain than any existing telephone system. A major reason for this is that the system participates in its own maintenance.

To accomplish this, No. 1 ESS continually scrutinizes its own performance. If a fault develops, the affected unit is switched out of service and a duplicate takes over. At the same time, a diagnostic program is called in to locate the circuit package causing the malfunction. The location of the package is typed out on the teletypewriter so that the majority of system troubles can be corrected quickly and easily.

This "dialogue" between man and machine is the key to all maintenance problems. It is often necessary, for example, to trace a call in order to find a reported trouble on a connection, but the ferreed switch in the No. 1 ESS network makes it impossible to visually follow a connection between lines and trunks. However, the temporary memory records the locations of all lines and trunks associated with a call in progress, and a special call tracing program will render all these locations to a maintenance man. He merely types in an instruction to trace the call to a specified line. The system will identify the calling line or trunk. This feature is now limited to calls within an of-

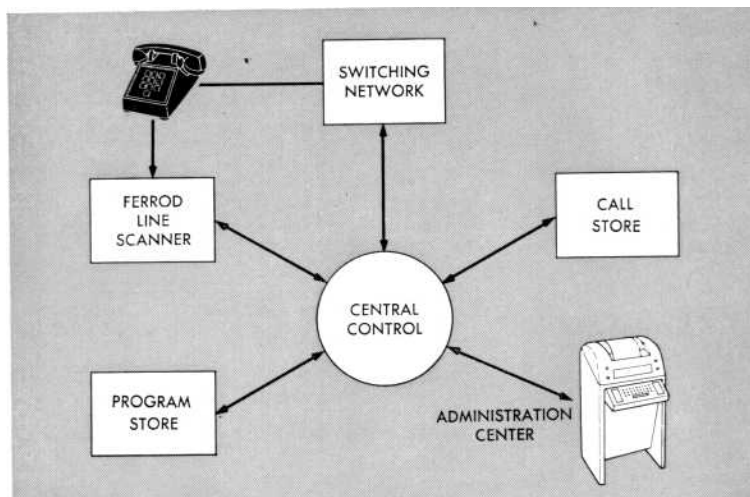

*A simplified diagram of the No. 1 ESS system showing the bilateral exchange between the central control and the other elements. The teletypewriter is the instrument of communication between the system and the administrative and maintenance personnel.*

fice. As No. 1 ESS grows in the Bell System, it will be possible to trace interoffice calls automatically.

Communication over the teletypewriter between administrative personnel and the system eases many administrative tasks. Many of these tasks are recurrent ones in all telephone offices. For example, translation data - which includes such things as the location of a trunk group that may be used for an outgoing call, the number of digits to be outpulsed, the equipment location of the called line, the type of ringing sent to a party line, etc. - is frequently changed. In electromechanical switching systems, this data is "recorded" in wired cross-connections and it is changed only by rewiring. In No. 1 ESS, translation records are stored in the memory, and they are changed by typing the new information into the system. This information can be stored and held in the temporary memory until the semipermanent memory twistor cards are changed.

At first thought, stored program control could be considered as a step that makes the operation of a switching system completely automatic. However, as we have seen, it actually provides a means of closer communication between the system and the people who maintain and administer it. In the final analysis, unique as No. 1 ESS is in the history of telephony, its design looks to essentially the same goal as the design of any telephone system. That goal, the ability to process telephone calls rapidly, efficiently, and economically, has been attained through stored program operation.



# The Stored Program

*Like the single thread which showed the way through a maze in a classical tale, the stored program of No. 1 ESS guides telephone calls through the labyrinth of control equipment and switching equipment in a central office.*

PROGRAM

CALL STORE

NETWORK

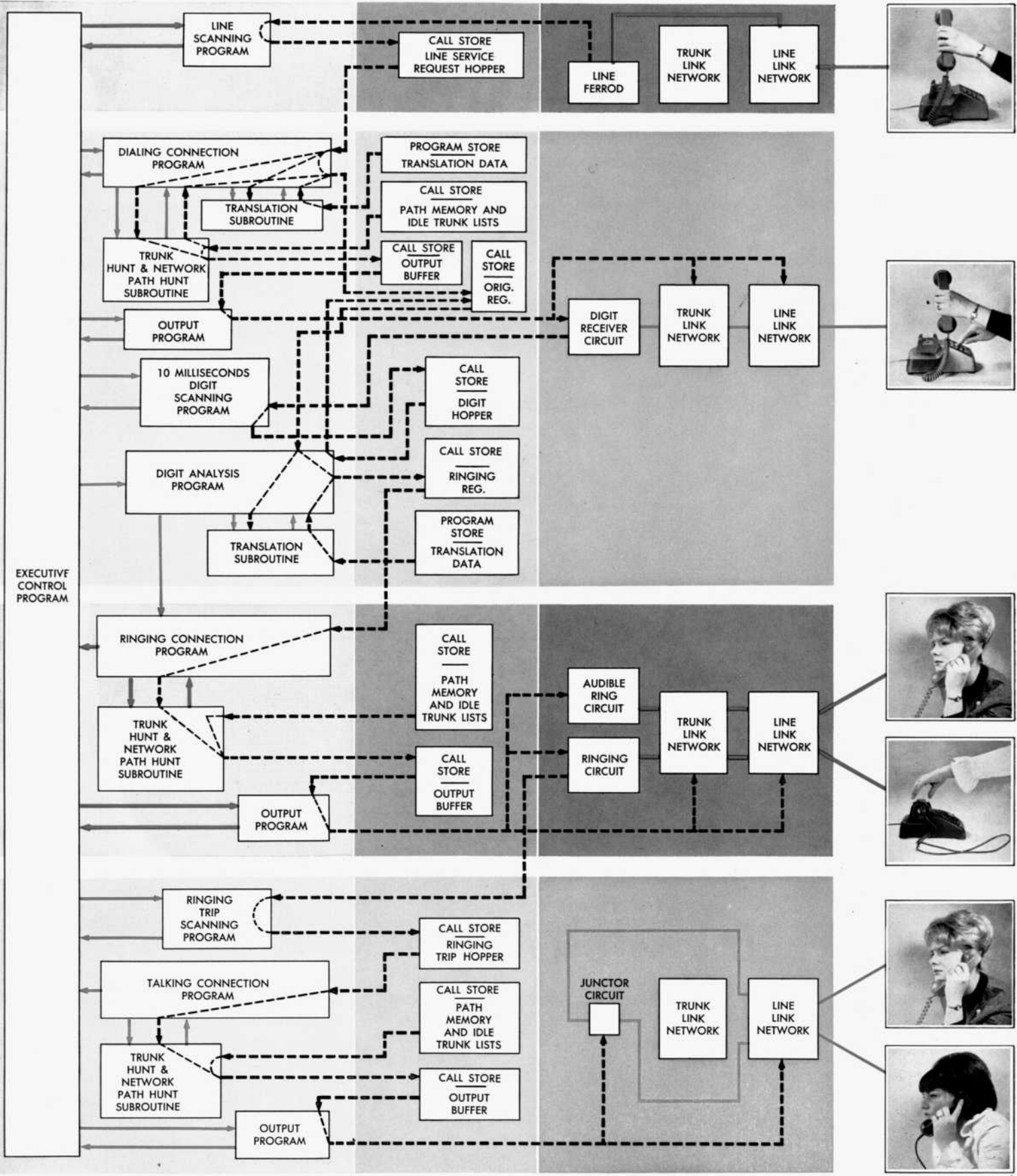



ANYBODY picking up and dialing a telephone at this moment starts a chain of switching actions that links his phone through a unique voice pathway to any one of the 88 million telephones in the United States. A million people may pick up their phones at the same time with similar results. If a few hundred of these people are served by the same central office, their calls are handled side by side although the connections for each one may be directed by separate groups of control equipment.

From the customer's point of view, No. 1 ESS will handle ordinary telephone calls in the same way an electromechanical office handles them. They will seem to go through side by side, and the actions set in motion when a call is originated will continue in an apparently unbroken sequence until the connection is made. Actually, No. 1 ESS works on only one call at a time; its enormous operating speed makes it appear to handle all calls simultaneously. Furthermore, while in an electromechanical system each action in the switching sequence triggers the action that follows it, in No. 1 ESS the program is the trigger. It may direct the system to send dial tone to a telephone originating a call, then make a connection to the switching network for a second call, go on to take down connections for a third call, and only then return to the first call to receive dialed digits. Thus any step in processing a single call is isolated, so to speak, from any other.

The actual circuit actions that accomplish each step in the processing take place in central control. Every 5.5 microseconds one of the 100,000 instruction words that make up the stored program directs central control in some basic action of call processing or automatic maintenance. The flow of actions follows a precise schedule because central control can execute only one instruction at a time and each step may have a different duration. For example, during dialing lines are scanned periodically to detect the dialed digits.

*This diagram shows all the programs that participate in advancing a call from its origination to the talking connection. The order in which the programs take control from the executive program can be followed by reading down the left side of the diagram. The large blocks represent the functional programs, the smaller ones are the various subroutines which gather specialized information as it is needed at any step in the progress of the call. This information is passed between the various programs by means of the call store hoppers, the buffers, and the registers in the memory section, in the center of the diagram.*

Scanning must be done fast enough so that no digit pulses are missed. On the other hand, the switching network operates more slowly. Hence, instructions to make connections in the network are issued at a correspondingly slower rate. These varying time cycles are reflected in the overall organization of the program.

The stored program contains five functional groups of programs each controlling a particular stage in call processing. First, *input programs* gather information such as the states of all lines, trunks, and service circuits. *Operational programs* examine this information and decide what, if any, output actions are required in response to it. The operational programs also call on *subroutines* to fetch data that the *output programs will* use. Finally, the output programs make and release connections in the switching network and operate relays in the trunk and service circuits. During the time that central control is involved with the specialized actions outlined by a functional program, that program actually controls the system. Each program assumes and relinquishes control on a strict schedule that is governed by the fifth functional group, the *executive control program*, which decides when each of the first four are to be called into operation.

To smooth the flow of the whole process, the call store memory acts as a clearing house of information between the functional groups. The call store is divided into many sections, each with a number of words, or memory slots, called registers, hoppers, and buffers, in which information is deposited and withdrawn as it is needed. One or more registers is associated with each telephone call being processed. Input programs fill the hoppers with input information that is operated on by the operational programs. These, together with the subroutines, stock buffers with output information for the output programs. Thus the processing of any call entails a constant interplay between the program store and the call store.

A familiar starting point for describing how a switching system handles a call is the customer's act of lifting his telephone handset from its cradle. In No. 1 ESS, as in all other systems, that act signals the origination of a call. But from that point on, No. 1 ESS is different from all other systems. The state (off-hook or on-hook) of a customer's line is reflected in one of the two possible states of the ferrod sensor. When the customer lifts his handset, the ferrod changes its state. (See *From Morris to Succasunna* in this issue.)

Every 200 milliseconds, the executive control program schedules an input program, called the line scanning program, that in turn directs cen-

tral control to scan all ferrods. The object is to discover which ferrods have changed state since the last scan, 200 milliseconds before. Each time it discovers a change, the program temporarily stops the scanning action and writes the equipment number of the originating line in a hopper reserved for service requests. The system always completes the immediate action on one line before it goes to the next. Thus, though it will take the same action on all originating lines, it works on only one at a time. When all the ferrods have been scanned, the scanning program returns control to the executive program.

At this point, any line that has gone off-hook since the last scan is identified in the service request hopper. The executive program now decides on the next action. To take further action on the service requests stored in the hopper, it must schedule an operational program. But it may decide instead to give control to an output program; for example, to operate the line switching network. A single network control device can be used only once in about every 20 milliseconds. But to preclude any possible "traffic jam," the program directs any controller to operate only once every 25 milliseconds and in the interval directs actions elsewhere in the system. Meanwhile, the service requests wait for an operational program. Thus, the initial step in the call may have no direct connection in time with the next step. This may also be the case with any other sequential steps.

The drawing on page 216 traces all the program steps that occur as a call progresses from its initiation to a talking connection. As the call moves through the office, control is handed back and forth between the executive control program and the functional programs. A functional program may complete a call processing step on one line, and then return control to the executive program. The latter may direct the functional program to proceed immediately to the next waiting line, or it may schedule another program. Any program is interrupted when a network operation or a digit scanning program is due.

Frequently, the system needs special information concerning its next step in a call. For example, conventional dial telephones and TOUCH-TONE® dial telephones require different types of digit receiver circuits. When a customer initiates a call, however, the system first detects only a change of state in the line. It does not know which type of telephone is involved, and therefore it does not know which type of digit receiver circuit to connect. The dialing connection program, which is in control at the time, gives the calling line's equipment number to a translation subroutine

which refers it to a translation "list" in the program store. This list contains information on the kind of equipment associated with the line. The subroutine passes the information back to the dialing connection program which then knows which type of digit receiver the line requires.

Every regular and specialized action in the process of making a connection between two telephones is thoroughly covered by one or more functional programs. Like a conductor who cues in each section of his orchestra at the proper time, the executive control program schedules the functional programs. The sections of the No. 1 ESS orchestra all play different themes that blend contrapuntally. And the final phrase in any call is a variation on the opening: When the conversation ends and both parties hang up, a scanning program detects a change of state in the ferrods and the system knows that the connection can be released.

The efficiency of this intricate plan turns on the precise scheduling of the various programs, particularly the input programs. Unlike output signals, which are controlled by the program, input signals originate at customers' telephones or in distant offices. If any are missed or received inaccurately, calls will go astray. Besides, many input signals, such as dialed-digit pulses, exist only momentarily, and may vanish unless the program that detects them is scheduled unerringly and unvaryingly to the millisecond. Input programs, therefore, take precedence over any other job in the system. Every 5 milliseconds the program in progress is stopped and an input program—digit scanning, trunk scanning, junctor scanning, or whatever-takes control.

If the programs were to time their own control periods, making the transition from a call processing routine to an input detecting routine every 5 milliseconds, they would all have to be written to account for both the random occurrence of inputs and the rigid timing requirements of such peripheral system equipment as the network frames and the multifrequency transmitters. However, because the executive control program determines which functional programs are to have control at any given time, the programs themselves need not be concerned with timing.

Two "timetables," each a matrix of binary digits in the call store, provide the executive control program with the specific timing indications it requires. One, the 20 X 5 millisecond timetable (see the drawing on page 219), is a matrix of 20 rows and 23 columns; the other, the 24 X 5 millisecond timetable, has 24 rows and 23 columns. In both cases, each column is assigned to one input program and at each row a binary 1 or a binary 0

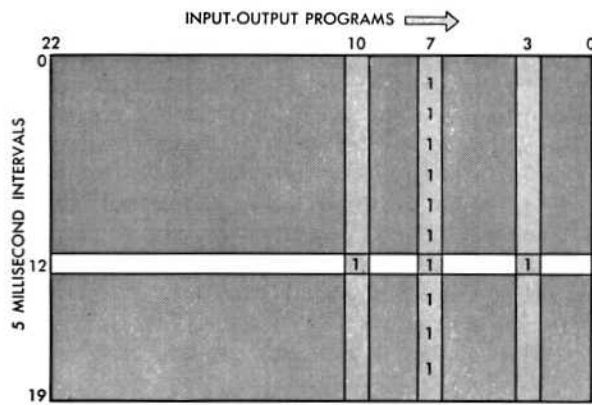

The 20 X 5 millisecond timetable contained in the call store memory. Each vertical column is assigned to a specific program which is executed whenever a binary 1 appears at the intersection of the column and a horizontal row. Thus, the program in column 7 is executed every other round, or every 10 milliseconds. At the 12th round the programs in rows 10, 7, and 5 are executed.

is written in the column. The rows are read in turn, one every 5 milliseconds, and whenever a binary 1 appears, the program for that column is executed. If a binary 0 appears in the column, the program is skipped that round. Thus, the program that controls digit scanning, which is executed every 10 milliseconds, has a binary 1 in every other row. Reading is continuous; when all rows are read, the cycle begins again.

An obvious limitation to these timetables is that they cannot be used for sequences that do not repeat themselves either every 100 milliseconds or every 120 milliseconds. Therefore, other timing sequences required by the system are generated by a "revolving counter." This technique is effective for any sequence that repeats itself regularly. A counter consists of a number of bits in a call store word. At regular intervals, the leftmost bit is rotated to the opposite end of the word. Whenever that leftmost bit is a binary 1, a program is executed. The signal to rotate the leftmost bit is taken from the 24 X 5 millisecond timetable.

For example, a dial pulse transmission program is performed reiteratively at 45 milliseconds, 60 milliseconds, 45 milliseconds, 60 milliseconds, etc. This sequence is triggered by the 7-bit revolving counter 1000100. At every third interval of the 24 X 5 millisecond timetable, that is, every 15 milliseconds, its output is applied to the counter, causing the leftmost bit to rotate. A complete rotation of the counter takes 105 milliseconds and a

binary 1 appears at the leftmost position every 45 and every 60 milliseconds.

The handling of the input programs underlines an idea that is indispensable to the stored program method of processing telephone calls: Certain programs can be delayed while others are executed. Simple as this idea sounds, the No. 1 ESS philosophy of time sharing one control unit among all the lines in an office would be unworkable if all programs had the same priority. Although few programs besides the input and output programs must be executed in real time, service requests must be dispatched with the least possible delay. Programs such as routine maintenance, on the other hand, can be deferred to slack traffic hours. All programs, therefore, are woven into a hierarchical order based on their relative importance.

A basic order of priority assignments is given to "task dispenser" programs, specialized programs associated with specialized buffers in the call store. The task dispensers are active links between the executive program and the "task" programs that carry out the processing routines on the data in the buffers. Because the buffers accumulate information of varying degrees of importance, they must be unloaded according to a strict priority scheme. Therefore, the task dispenser programs are grouped in six classes. The highest priority is called "interject;" the other five are classes A, B, C, D, and E. Class A dispensers, the highest priority of the five, cannot be delayed more than 200 milliseconds, while class E dispensers, the lowest priority, can be deferred as much as 2 seconds. A continuously repeating sequence governs the execution of the dispenser programs. Each priority class in the sequence is run twice as often as the class directly below it. The actual sequence -

ABACABADABACABABACABADABACABAE  
-contains class A 15 times, class B 8 times, class C 4 times, class D twice, and class E only once.

On links between the executive and the operational programs, the actual job of the task dispenser programs is to examine the data stored in the buffers and determine the operational programs that must be called in to operate on it. Specialized task programs are then called upon to do whatever the data calls for-direct a scanning program on specific lines, or start a network operation, for example. When it finishes its work, the task program returns control to the task dispenser which immediately checks for waiting interject work. If there is none, the task dispenser again examines its associated buffer, and the cycle continues. When all task dispensers in one priority class are completed and their buffers are cleared,

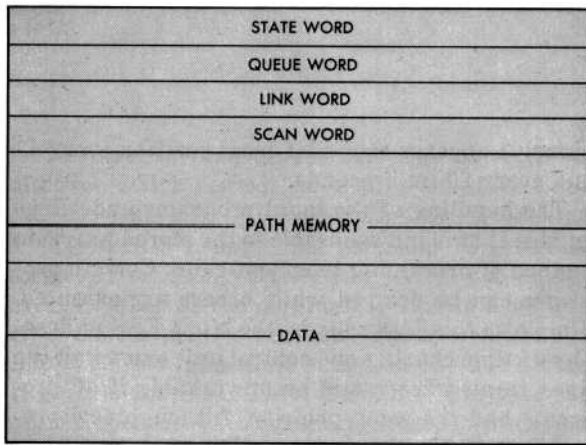

*Simplified layout of a call store register. The type of information stored in some words or parts of words varies with the type of call, and can change as the call progresses. The scan word is not always used. Its function is to link a call store register to a scanning register when the program orders that some point in the system be scanned.*

the sequence moves to the next class.

Interject programs may be "interjected" at any point in the sequence. One example, is the 1000 millisecond timing program which keeps a record of the time and the date and maintains a 10 X 100 millisecond timetable. This program is run every 100 milliseconds on an interject request from the 20 X 5 millisecond timetable. A program schedule in the 10 X 100 millisecond timetable may be executed when it becomes due ("times out"), or it may be rescheduled at a lower priority by writing a binary 1 (called setting a flag) in certain control registers. These flags direct the executive control program to execute specified task dispensers or to consult timetables that have periods larger than one second. This method of cascading timetables allows the executive control program to schedule programs that repeat as often as every 100 milliseconds or as seldom as once a week.

All the individual threads of the program that we have discussed are woven together in the call store memory. Every call, in its progress through the office, is assigned to a call store register which consists of memory slots for the temporary storage of input and control data. (See the drawing on this page.) Some stages of a call require more memory space than others. During digit scanning up to ten digits may be stored, for example. Thus, there are different sized registers for different stages of a call. However, the program subroutines handle all registers in the same fashion because the first three words of all registers, called the state word, the queue word, and the link word, respectively, are alike.

The state word identifies the register by its function-originating, outputting, disconnecting, etc.-and its particular state. The latter is shown

by an index called the program tag. When the register receives an input from a task dispenser, the state word selects a group of four task programs appropriate to the particular stage of processing. The exact program is selected from the four by reference to the type of task dispenser that delivered the input entry. Thus, instead of following a complex branching process to narrow down the choice of a program by many either-or decisions, the register simply looks for the proper program in a table.

The queue word links the register to a waiting queue when needed peripheral equipment, such as a ringing trunk, is tied up on another call. In this case, when the trunk becomes available, the queue administration program assigns the equipment to the register on the queue and transfers control to the task program selected by the state word.

The link word links a number of registers together if more than one is required for a call. This may occur, for example, on a call that is transferred to a remote station outside the central office. At one stage in this procedure an originating register, a temporary transfer register, and an automatic message accounting register are linked together. Any number of registers can be linked together by placing the address of the state word of the second register in the link word of the first register, the address of the state word of the third register in the link word of the second register, etc., finally closing the chain by placing the address of the state word of the first register in the link word of the last. Buffer entries to any one register in the chain can be passed to all of them. When a register receives a report of a buffer entry, its program tag is changed so that future entries will select the task program appropriate to the then current state of the call.

The No. 1 ESS program is obviously the operating intelligence of the system. Its structure is determined mainly by the very large call handling capacity demanded of the system, and the fact that it must respond to service requests in real time (as they occur). Although specific data such as equipment quantities and translations, which change from office to office, are not written into the program, they are easily added to the memory system in any office. If the details of a special service or feature is changed, or a new one is added, the program is easily modified to incorporate it. From this stems the considerable, but quite realizable, claim that No. 1 ESS can handle telephone features and services that have not yet been foreseen.

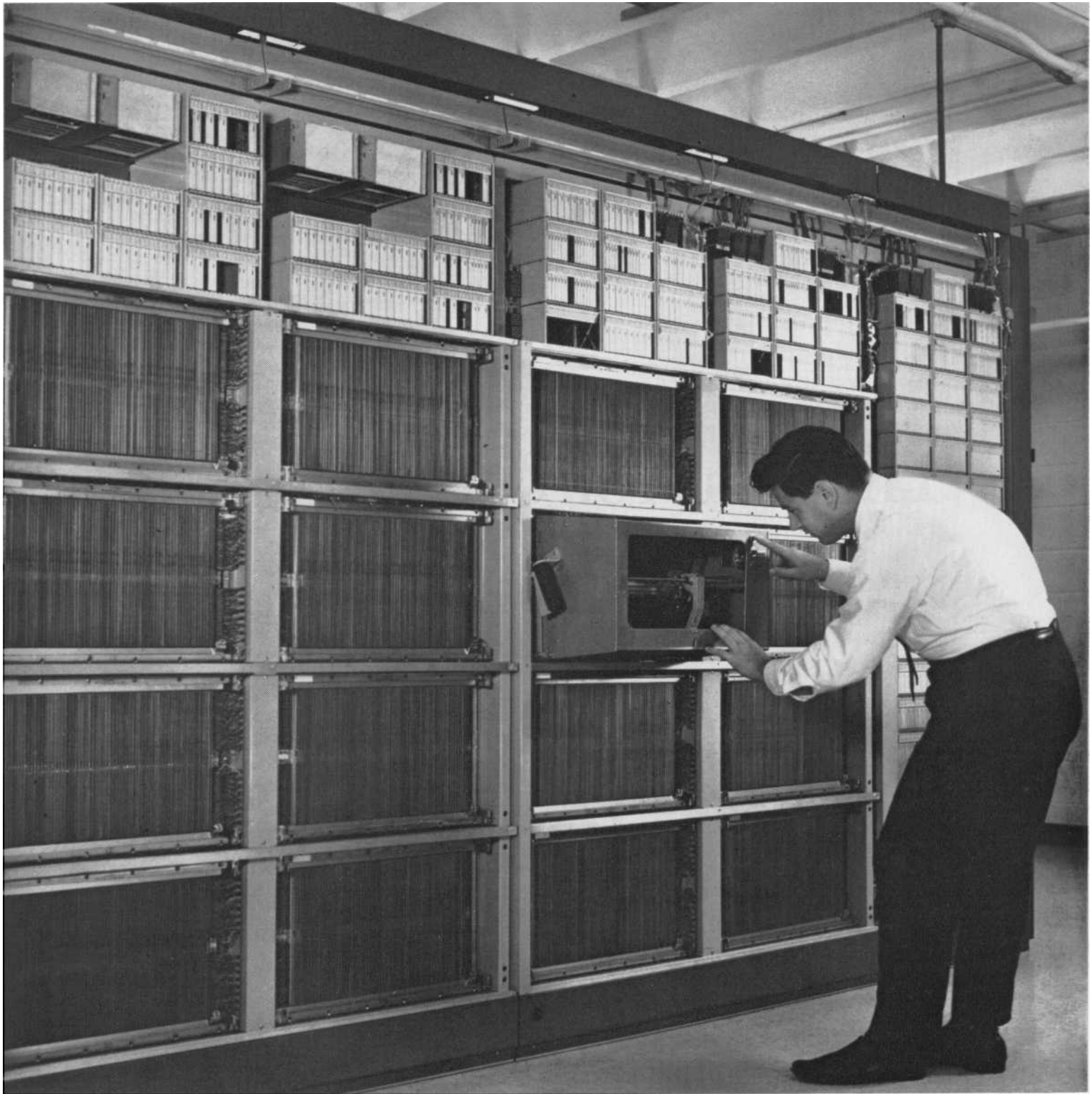

*The program store modules of the Succasunna office of ESS. These 16 modules hold more than 5 million bits of information.*

*The control unit of No. 1 ESS operates in the rapidly changing environment of a telephone central office. Its main task is to continuously monitor and control that environment so that all customers can be served efficiently and accurately.*

# The Control Unit

A. H. Doblmaier

THE CONTROL UNIT of No. 1 ESS, consisting of the stores and central control, is a binary digital machine that performs highly complex logic operations which interpret the instructions of the stored program for the system. All the telephone switching logic is contained in the stored program, but the processing logic resides in the 13,000 logic circuits of central control with their almost 60,000 semiconductors. To change system features requires changing the program, but as long as programs are written in a common machine language central control logic circuits will execute any orders they receive. Because this processing is performed at the high speeds of electronic devices, the control unit of No. 1 ESS represents the ultimate degree of common control—one control directs the entire system.

Central control, the active part of the control unit, decodes and executes the organized set of binary encoded program instructions at a nominal rate of one every 5.5 microseconds. Clock pulses originating in a 2-megacycle crystal oscillator establish the execution rate. The binary characteristic is basic to the design of the control unit. Logic circuit transistors, for example, are two state devices, switching between on and off in a few nanoseconds.

There are three major classes of instructions to central control. The first consists of orders for central control to *sense* the state of the environment. For example, an order may require examining the ferro line scanner associated with customers' lines in order to detect requests for service. Central control detects any change of state in the line as a binary zero or binary one signifying off-hook or on-hook. In general, scanning is used to detect inputs to the system.

A second class of instructions processes the input data. Processing steps may include manipulating the data within central control, storing the results in the call store and recalling them when they are needed, and obtaining auxiliary data from the program store. But the processing of data may not be a perfectly straightforward progression from one step to the next. Central control's real power lies in its ability to decide, at any stage in the sequence, whether to continue through the program in an uninterrupted line or to jump to another area. Central control makes these conditional transfers on encountering certain conditions. It may, for example, look at the contents of a register and, according to what it finds, either transfer or continue the program.

The third class of instructions generates out-

puts from central control for operating relays in a trunk circuit, closing a network path, etc. As a rule, a single instruction governs a single operation. The complete set of instructions, however, is general enough so that individual instructions can be combined in various ways to implement any combination of office features.

In processing instructions, central control's first step is requesting information from the stores. It may retrieve service requests from the call store and ask for the processing instructions stored at a particular "address" in the program store. In return the program store sends central control a two-part instruction stored at that address. The first part of the instruction tells central control what to do with the information being processed. The second part, the address, tells where to do it.

Central control carries out the actions through various registers and flip-flop circuits, most of which are functionally designated. Program store addresses are generated in a program store address register and the instructions are received by an order word register. Call store addresses are generated in an index adder and data from the call store is received by a data buffer register. An instruction decoder is attached to the order word register. The decoded output of the order word register, combined with an appropriate clock pulse, controls the gating of information through the registers of central control. (The diagram on page 224 shows the organization of central control.)

There are eight general purpose flip-flop registers within central control connected together by two common buses. One or more of these

(designated B, F, J, K, X, Y, Z, and L registers) usually is involved with processing an instruction. Designed to accommodate the basic word length of central control, each register is 23 bits long and the interconnecting buses each comprise 23 parallel information paths. A call store word is actually 24 bits, so the data buffer register is 24 bits long. The 24th is a parity check bit which drops out in the data buffer register.

A program sequence of instructions to central control might proceed as follows

*One.* Take a memory address from an index register and read the word containing the first dialed digit of a call. Mask out all bits in the word except the four used for the first digit, and store the word in an accumulator register. (Masking, done in a mask and complement circuit, consists of changing all bits in a word, except the significant ones, to zero.)

*Two.* Compare the word just placed in the register with the value 10 (the number of pulses counted when a customer dials zero).

*Three.* If the two compared quantities are equal, transfer to the program at an address specified in the instruction. If the quantities are not equal continue with the present program sequence.

Thus, at the third instruction central control decides if the customer has dialed zero (i.e. if the compared quantities are equal.) If so, it transfers to a program connecting the line to an operator. If not, it continues reading up dialed digits.

At any stage in a sequence central control may go to the registers for information. For instance, one of the flip-flop index registers may contain the address of a block of call store words needed in accumulating dialed information. One word from this block may be transferred to a second register where it can be used by the program. The task of central control, therefore, is to find that one word in the block of words and gate it to the appropriate register.

To begin, the program store sends central control an instruction to perform this task. That instruction might be paraphrased: Fetch the call store reading in the third word of a block whose starting address is stored in the Y index register and store the reading in the X index register.

*Central control acts on instructions stored in the call store and program store memories to process a telephone call or to diagnose a trouble spot. There are over 13,000 logic packs. Black squares at right center are groups of ferrod line scanners.*

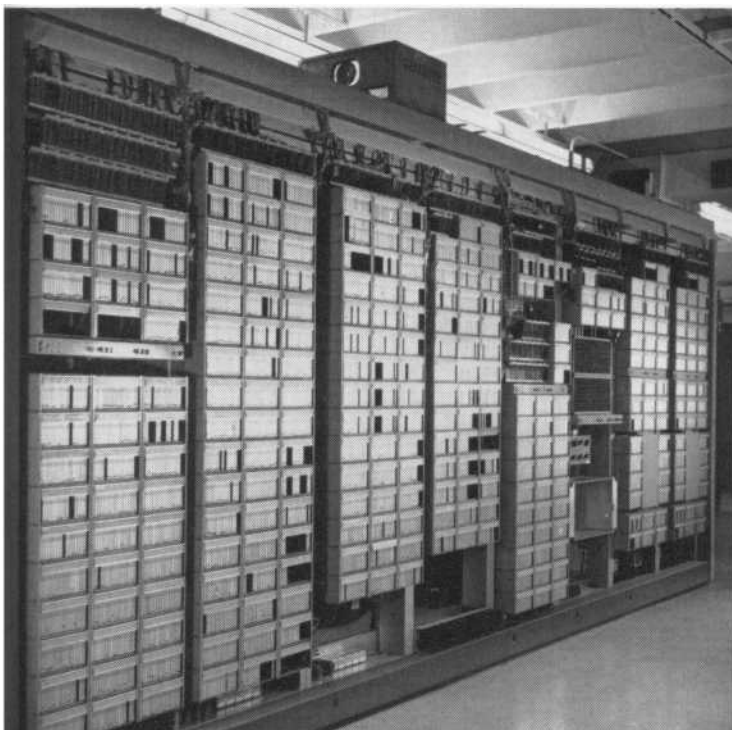

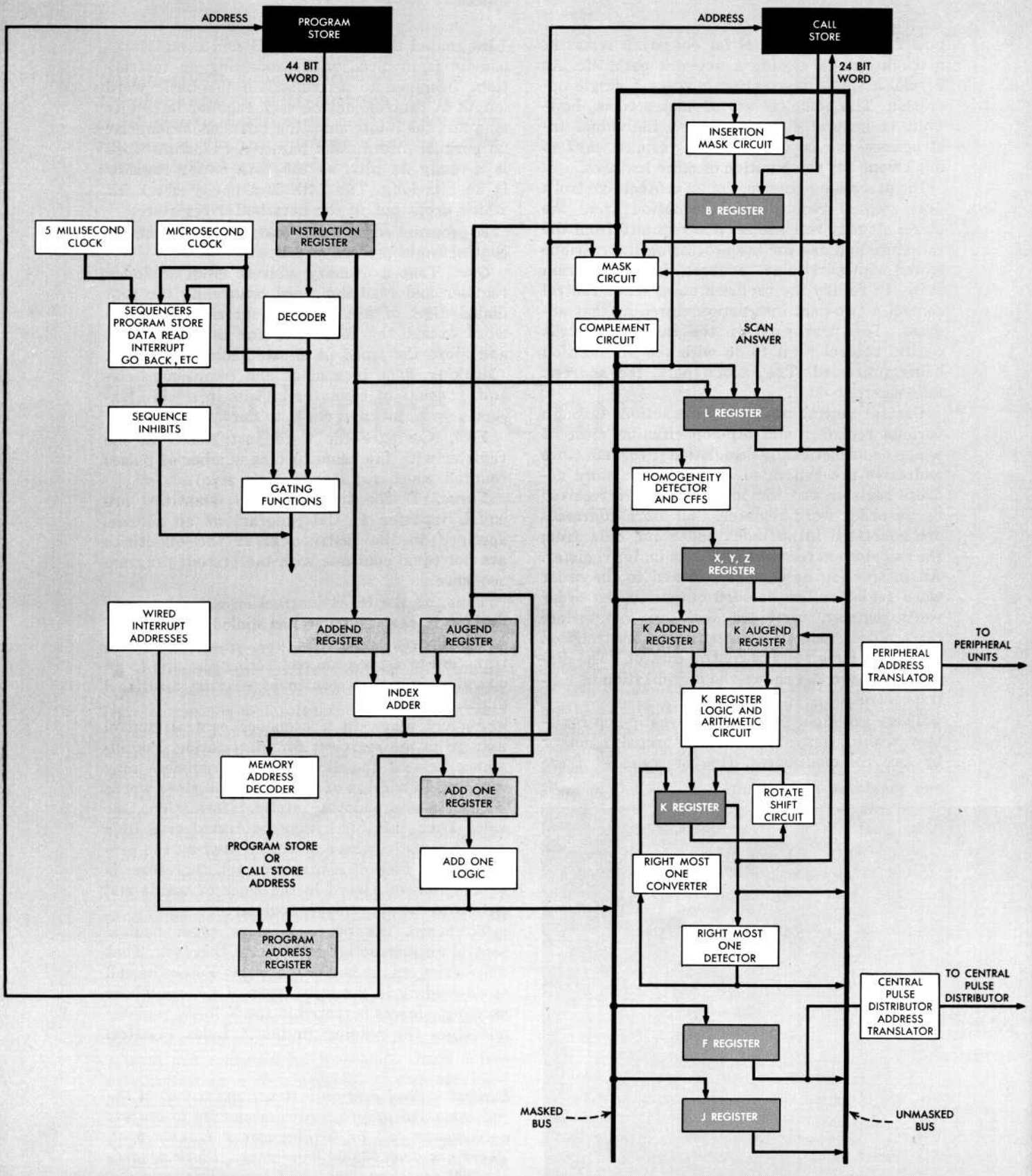



The actual instruction has three parts: first, the operation (fetch data from the memory and store it in the X register) ; second, a constant that identifies the pertinent word in the block; third, the address of the Y index register. All program instructions are written mnemonically. Memory to X register, for example, is written MX. If the constant in the second part of the instruction is, say, 3, then the instruction is written MX 3, Y.

To find the pertinent word in the block of words, central control sends two inputs to the index adder. One input is the constant of the instruction. The other is a variable representing the contents of the specified index register. The index adder adds the two and the output of the adder is the address of the desired word.

In processing data, central control manipulates arithmetic quantities and logic quantities, both of which are couched in the binary language of digital machines. Arithmetic numbers contain 23 bits, designated 0 to 22. The bit at the right, is called the least significant bit; the one at the left, the most significant bit. Bit 22, the sign bit, distinguishes between positive and negative numbers. For a positive number the sign bit is 0. Negative numbers are expressed as the "ones" complement of their positive equivalent, and their sign bit is 1. For example, +1 is 000 ... 001; -1 is 111...110.

An arithmetic circuit in central control adds, subtracts, compares, shifts, and rotates binary numbers. (Neither call processing, nor any other system function requires division or multiplication.) In addition to these arithmetic operations, the arithmetic circuit performs the logical operations AND, OR, and EXCLUSIVE-OR. (The role of the logic functions in line scanning is shown on page 200.)

In many cases, particular bits of information are not located in the most convenient bit positions in a word. This may occur, for example, if several small data words are packed together into adjacent bits of a large memory word. Masking can be used to isolate a word within a larger word, but it does not affect the relative bit position. To move these bits into a more convenient position, the word can be transferred to an ac-

*The basic organization of central control. For non-overlap operation (i.e. one instruction is executed before the machine begins to process the next) only a single instruction register is used with an associated decoder. For overlap operation, there are three instruction registers in tandem and decoders are associated with each one.*

cumulator register in the arithmetic circuit which shifts or rotates the bits to other positions in the word.

In rotation, bits are passed through one end of the accumulator register and reinserted at the other end so that no information is lost. One bit, or a few, or all the bits in a word can be rotated as necessary, and it can be done from left to right or in the opposite direction. (Actually, the word is rotated as a unit by any specified number of places.) In shifting, the bits are forced out of either end of the register, but the vacant positions are then filled with zeros.

Another useful function in central control data processing is the rightmost one function. It consists of detecting and identifying a binary one in the midst of a number of binary zeros in a word. The one may signify, for example, an idle trunk. If central control is seeking a trunk over which to complete a call, the one indicates an idle trunk in the group, the zeros, busy trunks. The word storing the states of the group of trunks is gated to the accumulator. A rightmost one detect circuit then gates the position of the rightmost one to the F register through the buses. (F stands for "first one".)

Sometimes, when a task is performed on a number of successive memory locations, it is convenient to set an index register to the binary value of the first memory address in the sequence, then to add 1 to the register to each succeeding word. This function, called "incrementing" is particularly useful in "looping" programs. For example, the instruction MX 3, Y gates the contents of the memory at the address Y + 3 into the X register. But MX 3, YA gates the contents of the memory at Y + 3 into the X register and increments Y by 1.

The index register may also be modified by changing it to an indexed quantity. In the instruction MX 3, YW, the W is the indexed quantity. This instruction changes the index register, Y to the value of W which is the original value of Y, plus 3.

A final index register modification sets up the memory address to a specified quantity. MX 300, SY reads the memory at address 300 into the X register and places the quantity 300 into the Y register. (In the program mnemonics SY means set up Y.)

Two general approaches are common in the design of machines like central control-asynchronous and synchronous. An asynchronous machine works on the basis of a continuous flow of actions, each one triggering the next. A signal verifies that one action is completed before the

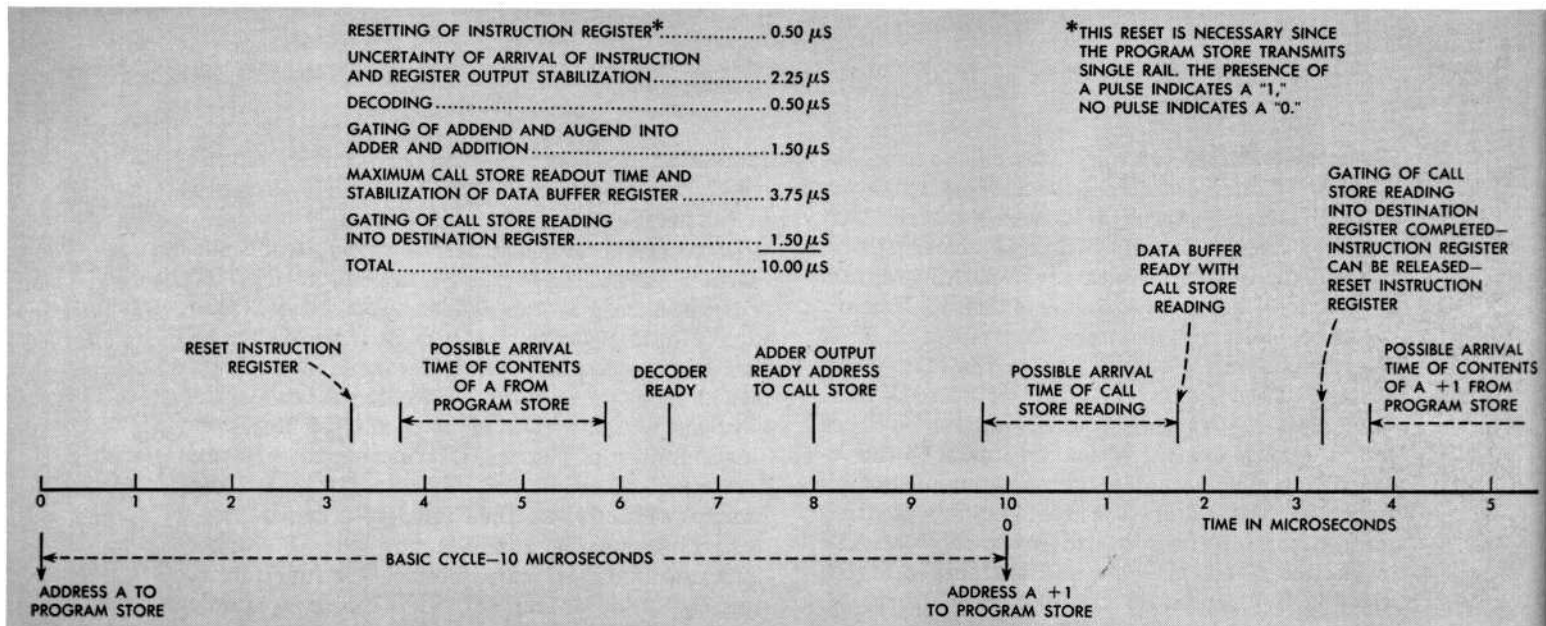

*Timing diagram for non-overlap central control actions. The 10 microsecond cycle is based on central control processing one instruction at a time, from preliminary to execution stages, before it*

*receives another instruction from the memory. Such operation could be handled by a much simpler central control, but it would incur a heavy time penalty and was ruled out for No. 1 ESS.*

machine moves to the next. This approach was ruled out for No. 1 ESS, because it makes matching difficult. (The significance of matching in the control unit is discussed in *A New Approach To System Maintenance* in this issue.)

In contrast, central control is a synchronous machine which, as we have described, performs only one action at a time. Clock pulses govern its stepping from one cycle of actions to the next. The duration of a single cycle—5.5 microseconds—is determined by the most time-consuming actions the machine performs.

Device aging could conceivably slow down the circuit actions in central control. Therefore, to insure a workable system through all stages of the life of No. 1 ESS, cycle time for central control actions was established on the basis of "worst case" design. Time intervals were computed by arithmetically combining the extreme end of life delays in logic stages, cables, and store responses thus ensuring a workable system even when all tolerances reinforce each other.

On this basis, cycle time would be 10 microseconds if central control were to complete the processing of one instruction before it moved to the next. Instead, the machine operates in an overlap mode—the processing of an instruction starts before the processing of the previous instruction is completed. (See the drawings on pages 226 and 227.)

An order is processed in two stages which we will call the preliminary stage and the final or execution stage. For example, take the instruction MX 3, Y once again. The second part

of the instruction, the 3, Y, is processed in the preliminary stage. First the components to be added are sent to the index adder under control of the buffer order word register. The index adder develops the address sum which is sent with a read command to the call store. The instruction then is "parked" in the order word register, leaving the buffer order word register free to receive another instruction. In the execution stage, the call store data is gated from the buffer order word register to the X register over the masked bus. This operation is controlled by the order word register. During the time the buses might be jointly used by two orders in central control, the order in the preliminary stage uses only the unmasked bus, and the order in the execution stage only the masked bus, thus preventing mutual interference.

Even though the reliability of the individual components in central control is exceptionally high, occasional errors and faults will occur in so complex a machine. To deal with these, all subsystems of the control unit are duplicated and the machine contains many error-checking features. The stores and central control are completely duplicated. Both central controls actually process all data simultaneously and match circuits compare the results at key points.

All program store words are encoded in a Hamming code that detects and corrects single errors and detects double errors. If a double error is discovered, the store is reread. Also, a single error in an address leads to a reread. Call store addresses all contain a parity bit which

is checked by the call store. A second parity bit is returned by the call store and a data parity checker affirms the overall parity. Various check signals from peripheral units are received in special registers and analyzed by match circuits.

In the event of a fault, or an error, central control usually tries to repeat the operation on which the failure occurred. A persistent fault triggers an interrupt and central control tries an alternative routine. For example, if a fault appears to stem from a program store the central control may attempt to execute a special program stored in the call store and designed to uncover the defective program store. If these pro-

cedures do not work, central control attempts to reorganize the system and establish a working configuration. As a final measure, an emergency action sequencer may take over control of the system and exercise different combinations of duplicated units and buses until it finds a working system. (For details see *A New Approach to System Maintenance* in this issue.)

Central control, then, is the executive part of No. 1 ESS. Although the flexibility of the system, as the preceding articles have emphasized, derives from the stored program technique, the effectiveness of the program itself depends on the efficiency of central control.

*The overlap mode of operation in the central control of No. 1 ESS. The machine processes two instructions simultaneously. As one arrives at the auxiliary buffer order word register, the address for the following one is sent to the program*

*store. The 5.5 microsecond cycle attained with this overlap operation approaches the ultimate capacity of central control. No additional significant increase in processing rate would be gained by increasing the complexity of central control.*

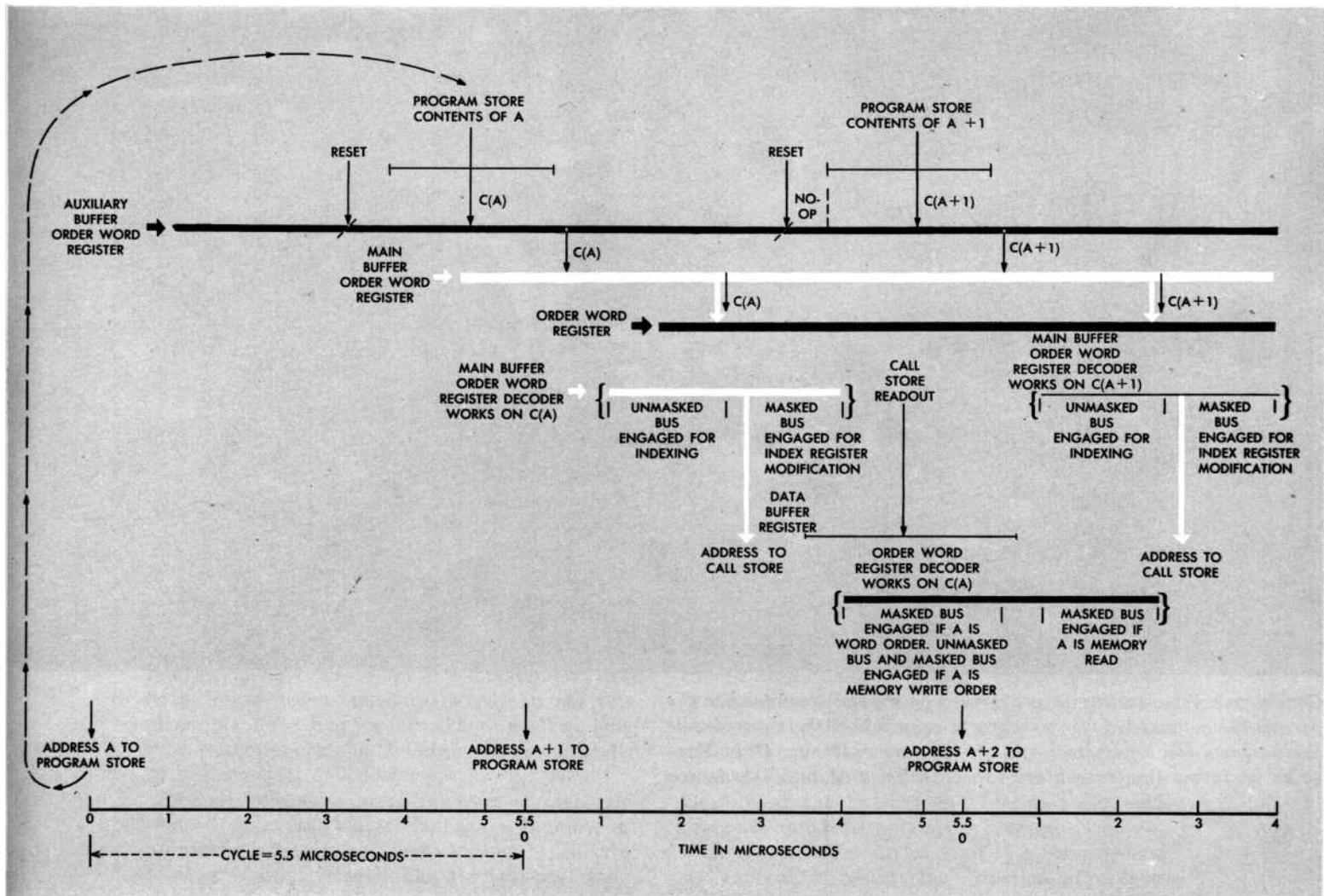



*Continuous pulse testing is performed on all twistor wire for the permanent magnet twistor memory to ensure that the signal levels are uniform for binary one and binary zero readouts. L. L. Vanskike performs the test on wire to be fabricated into the device.*

*All the telephone switching logic and any other data vital to the completion of telephone calls are stored as binary bits in the memory cells of two new memory devices in No. 1 ESS—the ferrite sheet and the permanent magnet twistor.*

# Memory Devices

R. H. Meinken and L. W. Stammerjohn

THE BASIC OPERATION of the memory devices in No. 1 ESS consists of storing a binary digit or "bit" in a specific location, called a memory cell, and recalling it on command. When memory cells are combined in large arrays, millions of bits can be stored in a single memory. Some bits are recalled after only a few millionths of a second. Others may be stored for years and recalled repeatedly as often as they are needed. To understand the operation of large memories, we can start with the behavior of a single cell.

A material or a device that has at least two stable states has memory. An ordinary light switch, for example, has two stable states, on and off, and by its position "remembers" a manual command. Electromagnetic switches or relays remember an electrical command, and they have functioned as memory devices in the telephone plant for many years. These devices, however, cannot operate at the high speeds demanded by modern electronic systems.

Memory elements prepared from specially developed magnetic materials have a number of properties that make them eminently suitable for high-speed systems. The fundamental prop-

erty, their two stable states, is expressed as opposite directions of magnetization. But more significantly, these elements can be made to switch very rapidly from one direction of magnetization to the other. Furthermore, the coercive force of the material provides a threshold of operation that prevents small amounts of extraneous energy from changing the direction accidentally.

In the last few years, magnetic core memories have been used widely in digital systems. Both the permanent magnet twistor memory and the ferrite sheet memory of No. 1 ESS are related to these. In the simplest form of core memory, thousands of cores are assembled in a coordinate frame of wires. Two wires intersect orthogonally (in the X and Y directions, that is) at each core. A core can be magnetized in either a clockwise or counterclockwise direction; one way represents a binary zero, the other a binary one. A general description of the operation of core memories is a good foundation on which to build a comprehension of the twistor and ferrite sheet memories of No. 1 ESS.

To store or "write" a digit in a core memory, we control, or select, the direction of a core's

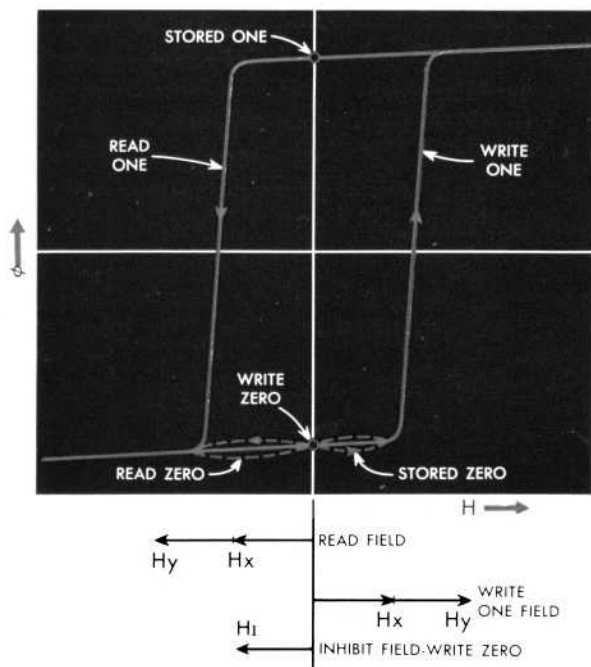

*Hysteresis loop of the ferrite material which composes the memory cell of the call store memory showing X, Y, and inhibit fields and one and zero flux states. The inhibit (write zero) field, added to the write one field, prevents the memory cell from switching and leaves the bit in the zero state.*

magnetization by passing currents through the wires. Half the value of the current required to switch the core is applied to an X-column wire, the other half to a Y-row wire. Since the value of the current in each wire is less than the threshold of operation, the magnetization of a core is not changed if only one of the wires passing through it carries current. Only the core at the intersection of the two wires that receives their coincident currents is affected. After it has been set in either direction, a core remains magnetized without any applied current.

To recall or "read" the digit stored in a core, coincident currents are used again. If a core at the point of coincidence is already magnetized in the direction that would be induced by the current, it does not change. But if it is in the opposite state, it switches, and the reversal of the magnetic flux induces a voltage pulse in a "sensing" wire. Reading the memory, then, consists of sensing the pattern of voltages and no-voltages.

In this description, we have reduced the reading operation to its simplest level, the single bit. A memory that could read out only one bit at a time would be thoroughly inefficient for a high-

speed system, however. Bits are actually strung together in parallel combinations, called words, and read out of the memory in aggregate. The structure and length of the binary words in any memory is determined by the requirements of the system. In core memories it is possible to form words of almost any bit length by connecting the cores in proper wiring patterns.

Up to this point we have been dealing with characteristics that are true not only of No. 1 ESS memories, but of the memories in many kinds of digital systems. Beyond these general ideas, however, the No. 1 ESS memories differ in significant ways from other memories and from each other. Electrically and mechanically, each is designed to suit its unique functions. These functions, described by the names temporary memory or call store for the ferrite sheet and semipermanent memory or program store for the twistor, have been discussed elsewhere in this issue. (See *Features and Services*.) Now let us take a detailed look at the most important principles in the design of first the ferrite sheet and then the twistor. After that we will consider some of the problems involved in achieving reliability and economy for these devices.

## The Ferrite Sheet Memory

The mechanical construction of the ferrite sheet memory is modular. Four modules compose one call store. A module contains 192 separate ferrite sheets arranged in three adjacent stacks of 64 sheets. The storage capacity of each call store in a No. 1 ESS office is 8192 words of 24 bits each.

A single ferrite sheet contains 256 holes on a 16 by 16 grid. The material surrounding each hole is a memory cell similar to a single core in the core memory. This material is a bistable ferrite (i.e. it has a "square-loop" magnetization or hysteresis curve) that is uniform in composition. It was specially developed for these characteristics to permit coincident-current operation.

The ferrite sheet memory is similar to the core arrangement that has been described. Four conductors, called X, Y, sense, and inhibit windings, carry the currents used in reading information

*The sense, inhibit, and X wires of the ferrite sheet are continuously threaded through all 64 sheets in each stack of the module. The Y wires are formed by interconnecting plated conductors on three sheets on each level. A single word is read out by selecting one of 64 Y inputs and one of 32 X inputs. The selected word is contained as one bit in each of 24 memory cells coupled to the two inputs.*

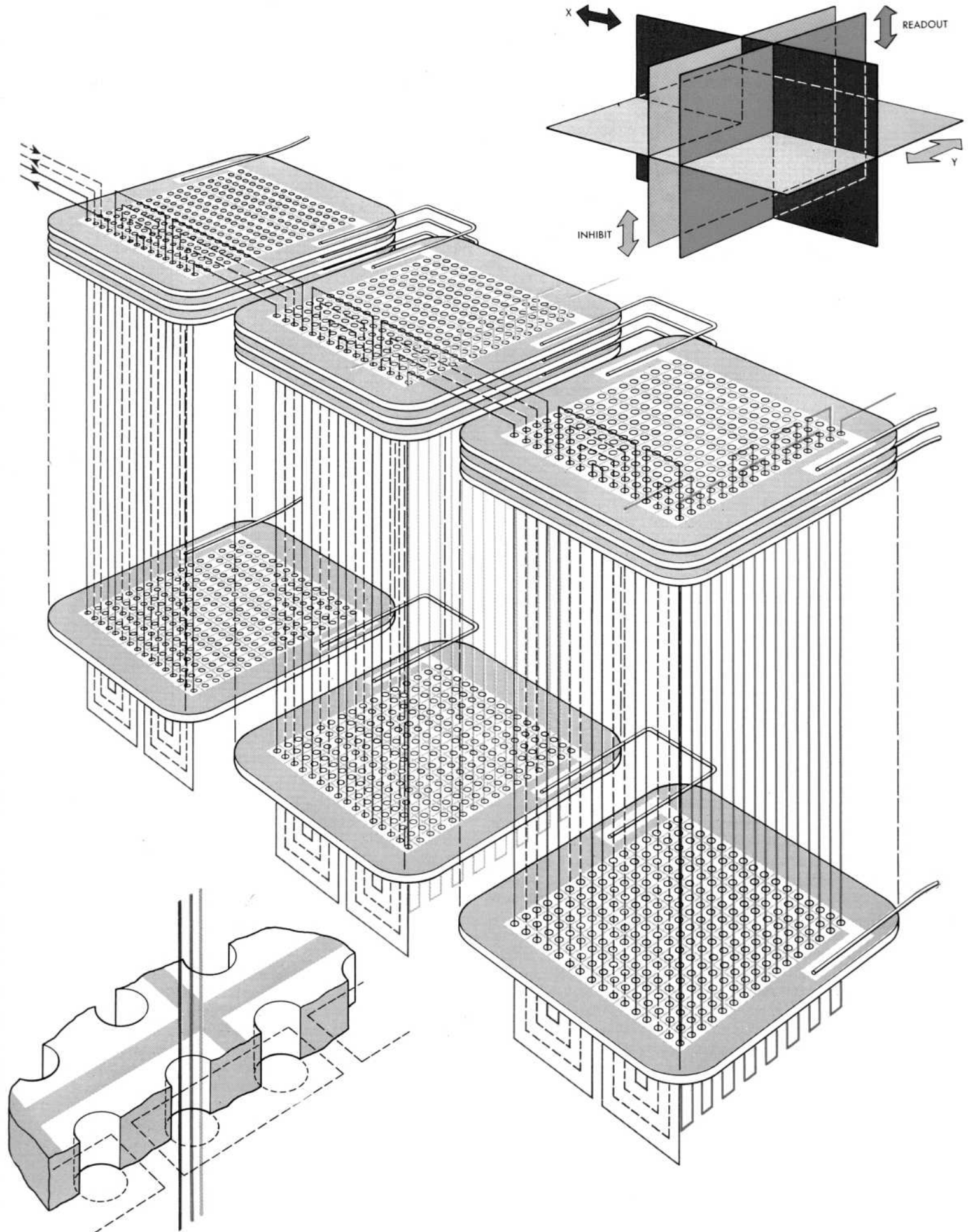

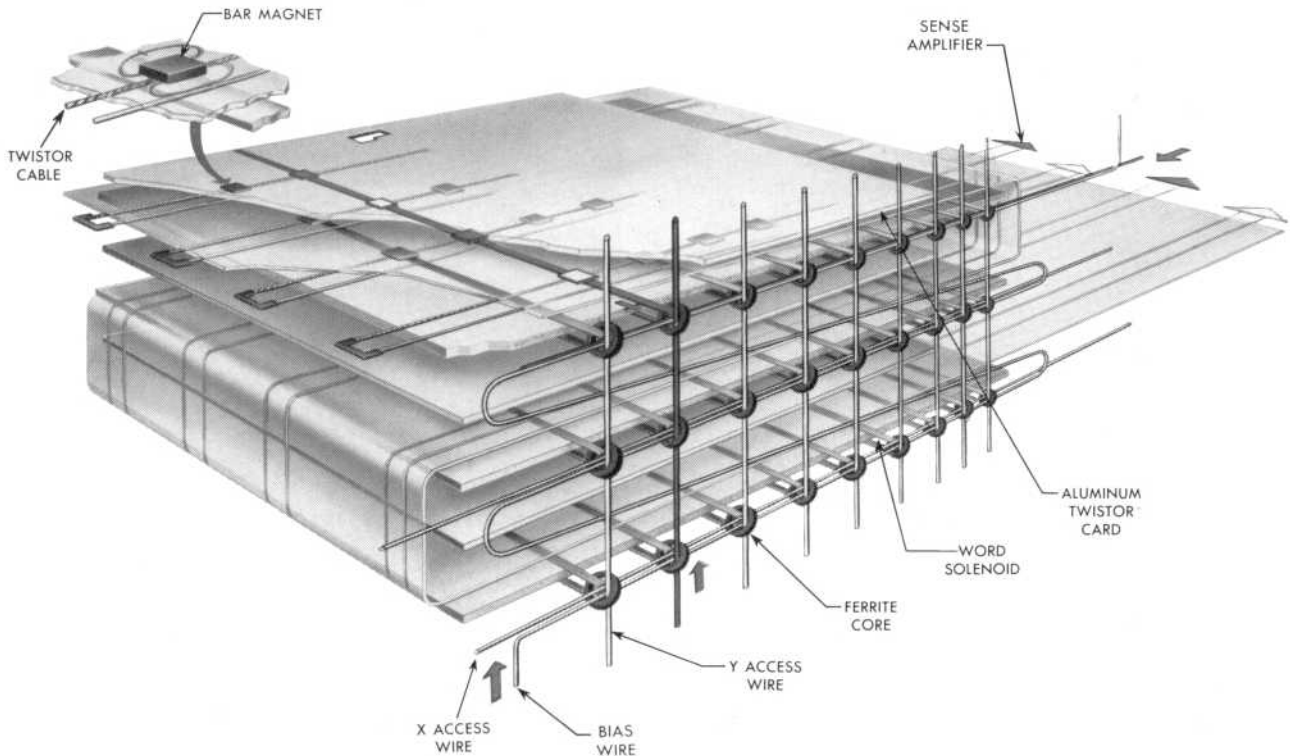

*Reading a word out of the twistor memory involves access windings, biased ferrite core switches, word solenoids, twistor elements, and sense amplifiers. Magnetized cells (binary zero) are the blue bar magnets in this drawing, unmagnetized ones (binary one) are white. The fields in two intersecting access windings select a core (the one at the intersection of the blue X-access and*

*Y-access wires) and induce a current in its copper solenoid. Twistor elements under unmagnetized cells switch and generate a pulse of a few millivolts which the white sense amplifier detects. Twistor elements under magnetized cells are biased into saturation and cannot switch. This generates a less than one millivolt pulse which the blue sense amplifier detects and interprets as a binary zero.*

out of the memory or writing it in. As in the core memory, coincident currents switch the memory cell at the juncture of the X and Y conductors. Pulses induced in the sense windings represent bits read out of the core. The inhibit winding is functionally named. To prevent a cell from switching during writing, a pulse is sent over this wire simultaneously with, but in the opposite direction from, the pulses over the X and Y conductors.

Reading and writing operations are performed in the following manner. The memory element is selected, or addressed, by a coincidence of X and Y currents. The current pulses are bipolar; that is, a negative current pulse is always followed by a positive current pulse. The first, or negative part of the bipolar pulse, reads the memory cell. The positive part of the bipolar pulse writes into the cell. Current pulses are applied to the in-

hibit winding only during the writing operation.

In reading, the negative field created by the negative current pulses reverses the direction of magnetization in a cell in which a one is stored. The change in the magnetic flux induces a voltage pulse in the sense winding. The amplitude of this pulse is read as a binary one. A cell in which a zero is stored, however, is changed in its degree of magnetization only slightly by the negative field. This small reversible change induces a much smaller voltage in the sense wire. This pulse is read as a binary zero. After a cell is read and the negative field is removed, it returns to the remanent flux state that represents a binary zero.

To write a binary one into a cell that has been read, the positive field created by the positive current pulse is applied to the cell, reversing its magnetization. Positive current pulses in coincidence in the X and Y wires produce this field. To



write a zero, however, really means to leave a cell essentially in the state resulting from the read operation. Therefore, the positive field applied to the cell must be weaker than the coercive force of the ferrite material. To achieve this, a negative current pulse is applied to the inhibit winding to create a negative field that opposes or cancels a part of the positive write field. Thus, the net field is not great enough to switch a large amount of flux in the cell. Following the write pulses, a negative pulse, called a post-write disturb pulse, is applied to the inhibit winding. This stabilizes the magnetization of the cell and improves its operating margins.

We have described the reading and writing operations on a single cell. To form the 24-bit word of the ferrite sheet, parallel operations are performed on 24 cells. Each cell, or bit, in a word is linked by common X and Y windings. Each inhibit and each sense winding links the bits in the same positions in each word of the module. In this way, a combination of one X, one Y, and one inhibit winding uniquely defines one bit in the memory.

A single module is wired with 64 Y conductors, 32 X conductors, and 24 interlaced inhibit and sense windings. Each path connects the cells it passes through in series electrically. Physically, each of these windings lies completely within a separate plane. Three planes containing one X, one Y, and one sense and inhibit winding are mutually orthogonal and their intersection defines a single bit or memory cell. The coincidence of an X and a Y winding plane, therefore, defines an entire word of 24 bits. A Y conductor, electroplated on each ferrite sheet during manufacture, links all the cells in that sheet in series. Each Y conductor in the module is formed by serially connecting the conductors of the three sheets in corresponding levels of the three stacks. The X conductor is a single wire threaded up and down through the cells in a stack. Inhibit and series windings are threaded through the cells in a similar fashion. The drawing on page 231 shows the wiring patterns in a cutaway section of the module.

Although coincident currents are required to switch a cell, a single pulse on either the X or Y conductor "half-selects" a bit and causes a small reversible change from the remanent flux of the magnetic material. This change generates a small voltage that interferes with the signal at the output of the conductor. In a large memory, the outputs of all half-selected bits linked by a common path add coherently and the sum of their amplitudes could exceed the wanted sig-

nal, causing errors in output information. To reduce this effect, the wiring patterns in a module are designed to cancel most of the outputs of the half-selected bits. Complete cancellation is not possible since the amplitude of this noise depends on the sense of information stored in the half-selected bits. Thus, noise due to half-selected bits is a factor limiting the size of the memory.

### The Twistor Memory

Now let us turn to the twistor memory. Its basic module is an accordian-folded stack of 64 flat planes, each having an array of 2816 twistor cells on each side. Into this stack are inserted 128 memory cards, one card facing each side of each plane. The cards, made of aluminum, bear a matching array of 2816 tiny permanent magnets (see the photograph on page 206) arranged in a grid of 44 rows and 64 columns. One program store (see page 221) contains 16 of these modules with a total storage capacity of 5.8 million bits of information. The store is organized into 131,072 words of 44 bits each. In contrast to the ferrite sheet memory, the twistor can be read an unlimited number of times without destroying the stored information. However, this does incur a penalty. Stored information cannot be changed electrically within the module. It is changed by temporarily removing the twistor cards and magnetizing or demagnetizing the permanent magnets.

These magnets, which are rectangles of vic-alloy, are the basic memory cells. A magnetized spot represents a binary zero; a spot that is unmagnetized represents a one. Twistor wire—a copper wire that has been helically wrapped with a thin permalloy tape—runs along the twistor plane under each row of magnets. A copper strap runs under each column, intersecting orthogonally with a twistor wire directly under each magnet. The intersection of a copper strap and a twistor wire forms a twistor cell which senses the condition of the memory cell or magnet. Twistor wires are formed into two flat cables that link all planes in a stack. Each twistor wire (there are 44 in a cable) reads out one bit in a word. A copper wire, parallel to each twistor wire, completes the transmission path for output signals. Each copper strap (there are 64 to a plane) defines the bits in a complete memory word.

The manner in which the twistor cell senses the state of the vic-alloy magnet can be described quite simply. (See the drawing on page 232.) Magnetic flux in the permalloy tape wraps helically around the twistor wire and links both the wire and the copper strap at every intersection. Because this flux path closes through the air, the twistor cell is

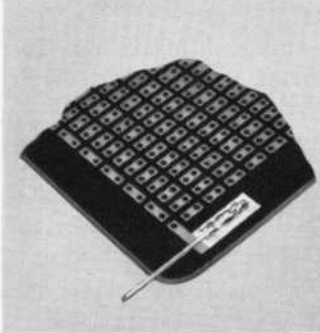
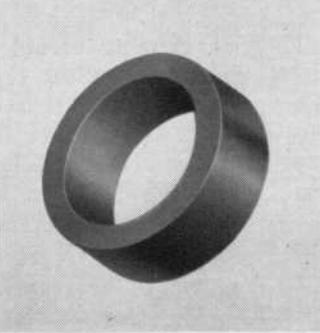
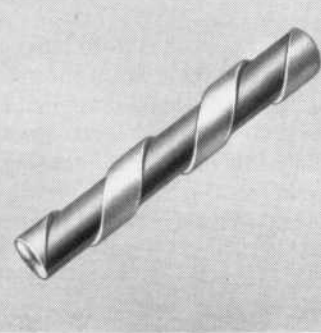
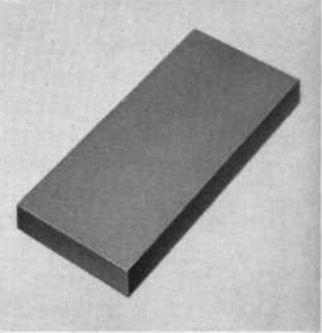
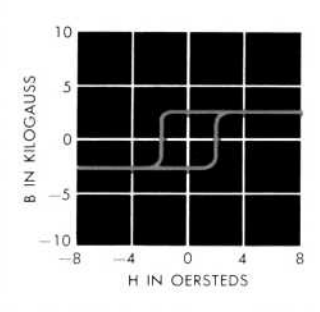
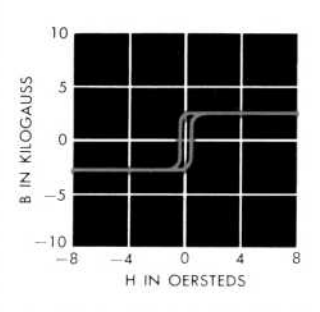
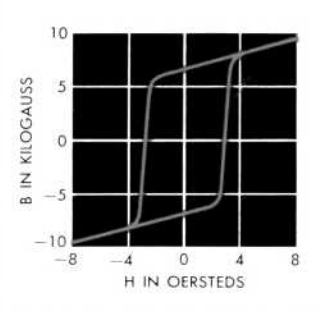
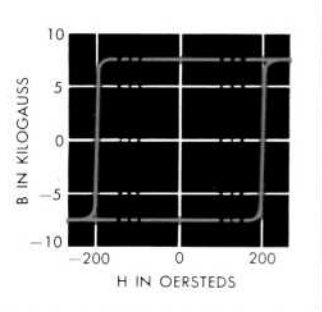
MATERIAL:	FERRITE	FERRITE	PERMALLOY	VICALLOY
COMPOSITION:	Fe, Mg, Mn	Fe, Cd, Mg, Mn	Ni, Mo, Fe	Va, Fe, Co
USE:				
STATIC HYSTERESIS LOOP:				
$B_r$ :	2000 GAUSS	2000 GAUSS	7000 GAUSS	8000 GAUSS
$H_c$ :	2 OERSTEDS	0.2 OERSTEDS	3 OERSTEDS	200 OERSTEDS
SQUARENESS:	0.97	0.95	0.7	

*Characteristics of magnetic materials in the ferrite sheet and the permanent magnet twistor memories. Left to right: ferrite sheet, twistor ferrite core switch, twistor wire, and twistor card vicalloy magnet.*

sensitive to ambient magnetic fields. Thus the strong field of the vicalloy magnet can affect the operation of the twistor cell. If the spot over an intersection is not magnetized, the field due to a current pulse in the strap will reverse the magnetization, i.e. switch the twistor cell. This induces a voltage pulse in the twistor wire which is read as a binary one. On the other hand, if the spot is magnetized, its external field saturates the permalloy tape at the intersection. Then the pulse in the copper strap cannot reverse the magnetization of the twistor cell. Therefore, only a small change of flux takes place, inducing only a small voltage in the twistor wire. This voltage is read as a binary zero.

Random access to any word in the twistor memory is provided by connecting each copper strap to a ferrite core in a matrix of biased core switches. These switches operate much like the cores of a coincident core memory except that their threshold field (the field necessary to make them change state), is generated by a current in a bias winding, not by the coercive force of the magnetic material. Two sets of access windings -one running parallel to the planes, the other per-

pendicular to them-connect the switches to the memory input terminals. The core selected by the two energized windings acts as a current transformer and generates the current pulse in the copper strap.

Uniform behavior of magnetic memory cells depends primarily upon uniformity of the magnetic properties of the materials from which they are made. In both the ferrite sheet and twistor memories, these materials have been developed to have the characteristics necessary for memory operation (see the table on this page.) The story of the development of the twistor material is told later in this issue. (See *Some Magnetic Materials.*)

We have discussed only the basic operation of the permanent magnet twistor memory. Several features of the design are important to No. 1 ESS. The magnet card material is aluminum. Because of its high conductivity, the card serves as an integral electrical part of the memory, as well as a mechanical means of placing the magnets properly. Eddy currents flowing in the card that arise from currents in the copper straps produce additional magnetic fields that add to

and enhance the original fields. This makes the copper word strap more efficient and reduces its impedance.

Because it is grounded through the retaining spring structure and the frame of the module, the card also serves as a conducting ground plane which reduces common-mode noise in the twistor line. A permalloy sheet, placed under the copper straps, also contributes to the effectiveness of the strap currents. The permalloy concentrates the magnetic field of the strap current in the vicinity of the twistor cell. It serves also as a distributed magnetic shield that reduces the effect of unwanted ambient magnetic fields.

Reading and writing in the memories, then, can be described in terms of a single bit and the operations on a memory word are parallel interactions of the basic action. But the construction of the No. 1 ESS memories must be considered in terms of blocks of cells.

Among the primary design goals of both memories were low first cost and low maintenance cost. It would be prohibitively expensive to fabricate individual cells and then interconnect them. The solution to the problem of low first cost is to fabricate a large number of cells and their interconnections in a few common steps. Low maintenance cost depends upon building a device with long life and stable characteristics so that adjustment during service is unnecessary.

Memory cells must be exceptionally uniform, because if a single cell fails an entire module is rejected. Materials and processes were developed to promote uniformity. The memory structures were designed to support the cells so that changing ambient conditions affect them as little as possible. In common with older magnetic components, such as transformers, the No. 1 ESS memories should not show any appreciable aging due to changes in their primary magnetic characteristics.

In the ferrite sheet memory, the 256 cells of each single sheet are formed simultaneously. Ferrite powder is pressed into the sheet which is first fired and then metallized. During the last step, the Y conductor is plated directly on the sheet. The frame of the module is designed to hold all the sheets in alignment and support them without strain. This meets the mechanical objective and it also facilitates wiring. As a result of this method of manufacture, the ferrite sheet memory, in comparison to earlier core memories, requires fewer interconnections. The result of this is significant improvement in first cost and reliability.

In the twistor memory, the objectives of a

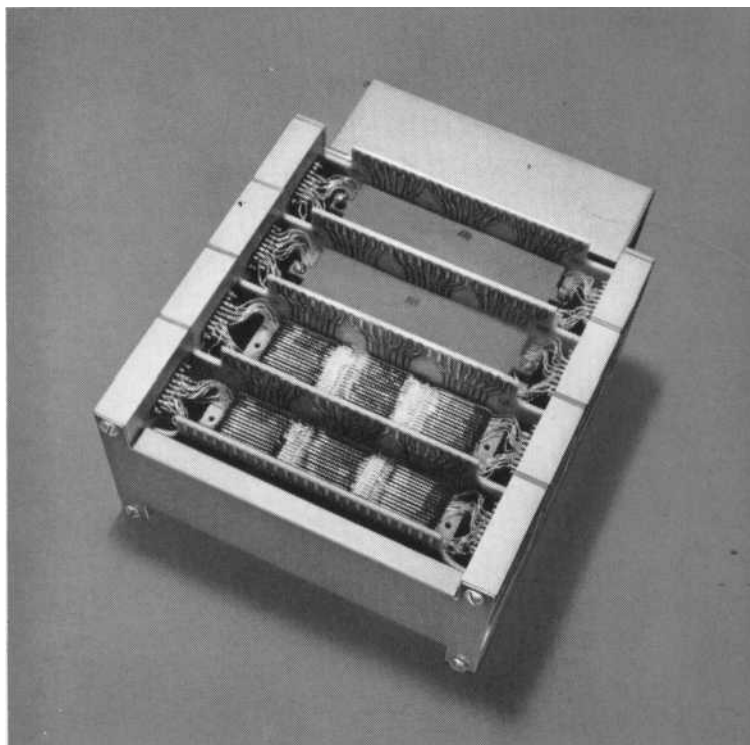

*One module of the ferrite sheet memory. An office of about 10,000 lines generally requires two or more call stores (8 modules). A 65,000 line office with a high calling rate may contain .40 stores.*

minimum number of connections and the elimination of mechanical strain on the magnetic elements are achieved in one operation. The twistor wire cable, running continuously through a module, is laminated between sheets of polyester which hold the wires in precise position and protect them as well.

The memories for No. 1 ESS have been designed specifically for their application in a digital control system which must operate continuously in real time. The permanent magnet twistor provides a semipermanent memory device uniquely suited to the storage of program and translation data in this system. General purpose digital computers use no directly comparable memory device. The ferrite sheet memory, while its electrical properties are directly comparable to the core memories in general use, is an exceptionally compact memory containing about 350 bits per cubic inch. Excluding terminals and connectors, the density is 8000 bits per cubic inch. For comparison, the twistor memory contains about 250 bits per cubic inch.

In the last three years, the Western Electric Company has manufactured many twistor memory modules and ferrite sheet memory modules. Test experience has amply demonstrated the uniformity of the electrical performance in these memories and the efficiency of producing arrays of memory elements in common operations on a large scale.

*All the highly sophisticated control actions described in the previous articles point toward one goal - establishing the speech path that bridges two telephone customers. The switching network makes the connections forming this bridge.*

# The Switching Network

A. Feiner

THE HISTORY of the telephone switching network is marked by the periodic introduction of new apparatus—Strowger switches, panel and rotary selectors, crossbar switches, and in the Morris trial, a network of gas tubes. The switching network of No. 1 ESS, built upon the ferreed switch, falls between electromechanical switching methods and the all electronic methods of the Morris office.

A natural control philosophy for the network accompanied each new switch. In step-by-step exchanges, the switches themselves participate in interpreting the dialed information and choosing the network connection. In the crossbar network, the markers consult the memory contained in the third switched lead, called the "sleeve," to find a set of idle switching links and make a connection. The gas tube network introduced "endmarking;" voltage marks placed on the end terminals caused the tubes in between them to break down, thus establishing a path between

telephones. In No. 1 ESS, the logic and memory functions that generate control information for the network are completely divorced from the network itself.

Why not an electronic network for an electronic switching system? The gas tube network of the Morris office was a technical success, but it had serious drawbacks. Most prominently, gas tubes could not carry high amplitude 20 cycle ringing signals, and so were not compatible with most types of existing telephone sets. The balanced metallic contacts of the ferreed switch (RECORD, *February 1964*) permit conventional supervisory and alerting signals, do not stand in the way of new transmission techniques, and meet the requirements of high speed.

Actually, the need for a high speed network does not arise—as it may seem at first glance—from a desire to make faster connections between telephones. The real need is for a network that can work compatibly with the high speed control



*J. Bodirae, a Western Electric craftsman, performs an installation test on line switching frames.*

circuits of an electronic office and that can be used not only for final speech connections but also to connect information receivers, senders, ringing circuits, and other equipment when they are needed. Because the No. 1 ESS network performs all these actions its trunk and control circuits are greatly simplified. However, about four network connections are needed for every call.

The No. 1 ESS switching network (see the drawing on page 238) is called "octal," a name derived from its eight stages of ferreed switches, in which each switch is an eight-by-eight array of crosspoints. This plan is a compromise between three important factors—complexity, economy of crosspoints, and maximal size (i.e. the number of lines and trunks a single office can serve.) A network of four-by-four switches, for example, would need more stages to attain the same maximal network size and equivalent blocking performance. It would contain fewer crosspoints, but the saving would be offset by more complex wiring and con-

trol requirements.

The octal network is composed of two types of four-stage subnetworks—the line-link and trunk-link networks. Any network, up to a maximum size of 64,000 lines and 16,000 trunks, is assembled from these basic units. Link networks are connected through the junctors to establish traffic paths for the three common types of central office calls—intraoffice, interoffice, and tandem (trunk-to-trunk) calls. One novel feature of No. 1 ESS is that intraoffice calls through intraoffice junctors bypass the trunk-link network. The junctor circuits extend battery circuits and supervisory signaling circuits to these calls. All other traffic is connected to the battery and supervised at the trunk circuits.

Line traffic in a No. 1 ESS office is concentrated in the first two stages of the line-link network. In a typical No. 1 ESS office, 64 lines have access to only 16 second-stage links. This two-stage, four-to-one concentrator configuration

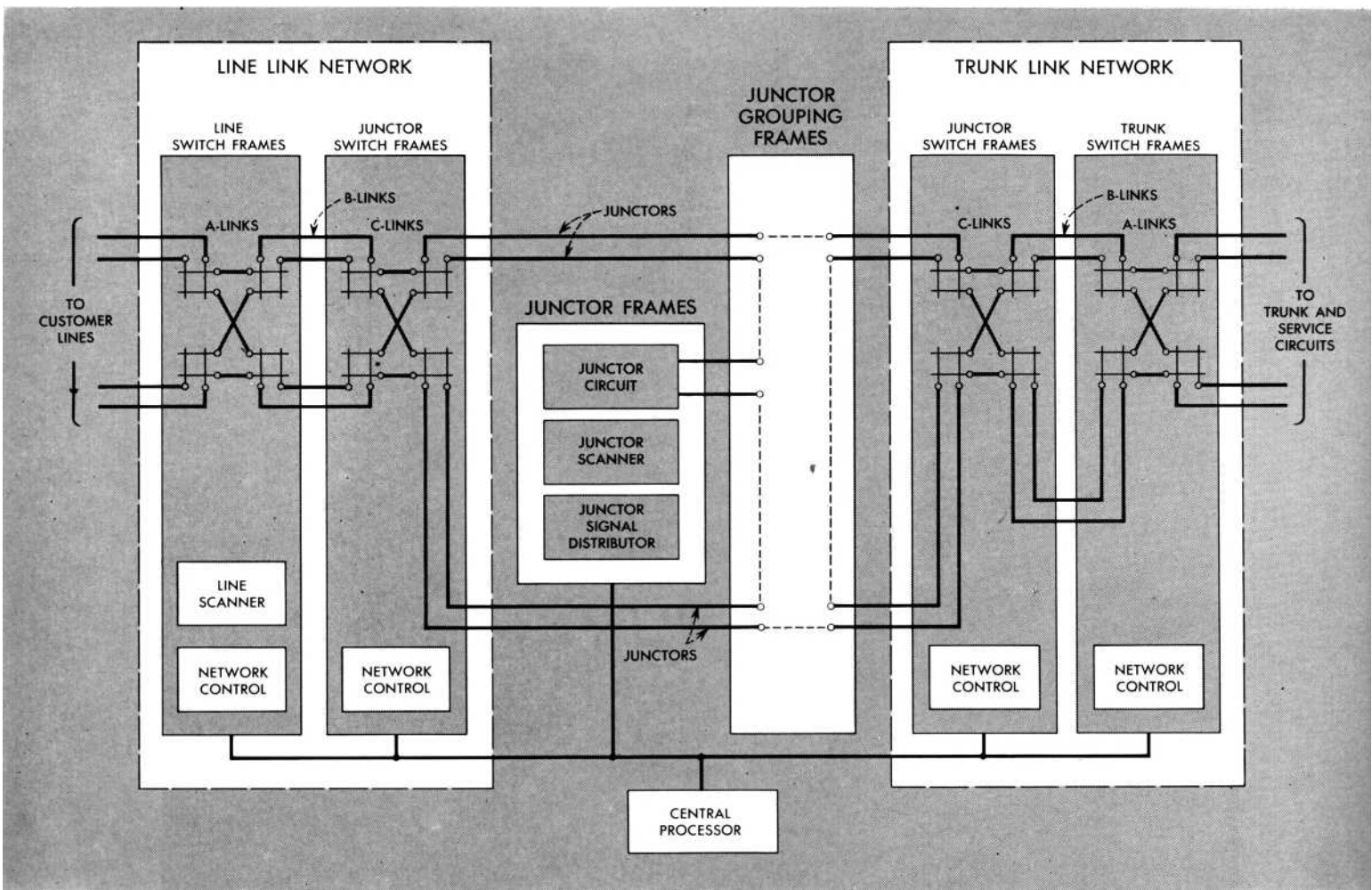

*The general organization of the No. 1 ESS switching network. Its building blocks are the line-link and trunk-link networks, each of which contains two types of equipment units. Two stages of the network are packaged in each of those units.*

*In addition to the ferreed crosspoints, the line switching frames house the line circuit equipment containing a ferreed and a bipolar ferreed for each line. This equipment is analogous to line relays and cut-off contacts in electromechanical systems.*

is uniquely efficient in its use of crosspoints. It requires only six crosspoints per line and its traffic performance equals or surpasses that of previous four-to-one concentrators which typically required ten crosspoints.

Sixteen line concentrators, their control circuits, and the line scanner are packaged in each line switching frame. The scanner and the line connect through a single bipolar ferreed which disconnects the scanner element (the ferreed) from the line after the system recognizes a request for service. The bipolar ferreed has only one winding and its contacts open or close in response to the polarity of the control current.

The other network stages are packaged in junctor and trunk switching frames. Each contains two stages of eight-by-eight ferreeds providing 256 inputs and 256 outputs. In the junctor frame, one additional ferreed is associated with every junctor output. Independently controlled,

this switch is an access point through which operators can verify a connection and it is also used for some specific system tests on established connections. It is generally called the "no test" access.

A fully equipped line link network (see the drawing on page 239) contains four line switching frames and four junctor frames with a capacity of 4096 lines and 1024 junctors. If the calling rate of an office is unusually light, the concentration ratio of the network can be increased by adding line switch frames and multiplying the "B" links. For busy metropolitan offices, a line switch frame has been developed with a basic concentration ratio of two-to-one.

A fully equipped trunk link network contains four junctor switching frames and-for a one-to-one trunk concentration ratio-four trunk switching frames. The number of these frames also can be increased in situations where the amount of

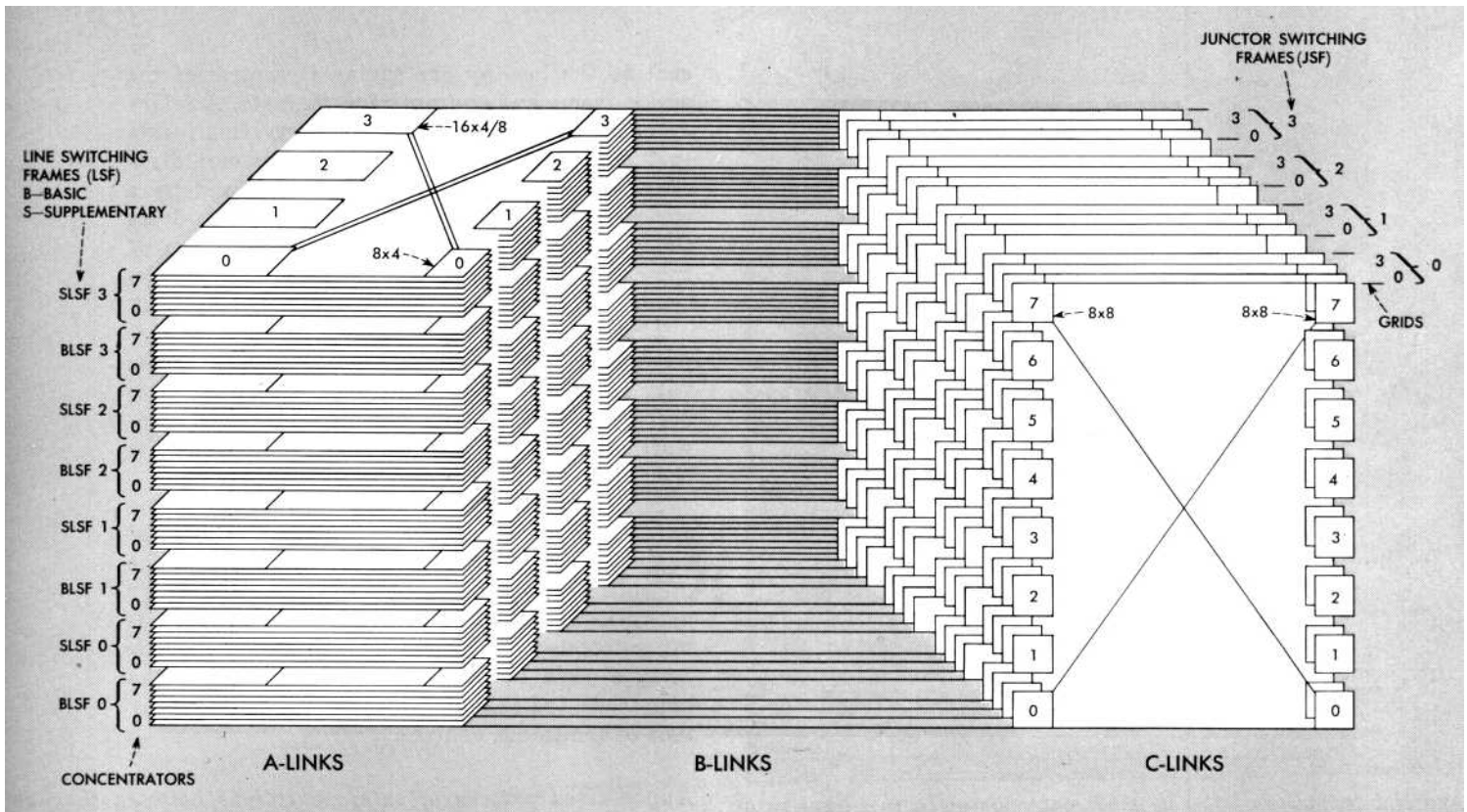

*The internal relationship of the four stages of switching in a line-link network showing interconnections and component equipment units. A fully equipped line-link network with a four-to-one concentration ratio contains 4096 lines and*

*1024 junctors connecting to other line and trunk-link networks. A trunk-link network can be shown in much the same kind of diagram by replacing the concentrating switches with eight-by-eight switches in the first two stages of the network.*

traffic warrants a larger concentration ratio. A jack and plug arrangement at the junctor grouping frame facilitates changes in the inter-network cabling during growth or a change in the traffic pattern.

Control of any switching network with its multiplicity of possible switching paths for any telephone call, requires some form of memory to tell the system which links are busy and which are idle at any given time. Conventional central offices use a sleeve lead as the memory, and the system tests the sleeves before hunting for a path. No. 1 ESS, however, uses the call store memory to control the network in a unique manner.

A special area of the call store, known as the network map (see the drawing on page 240), contains a record of the busy and idle states of all links in the office. One bit of information—a binary zero or a binary one—identifies the state of each

link. When the system needs a path for a call, therefore, it need not consult the network, but only the map. While a call is in progress, every link in its path is identified in a "path memory word" written into the call store. These links are marked busy in the network map. As soon as the talking parties hang up, the links are marked idle in the map and the memory path word is erased from the call store.

The central processor actually decides what path to set up through the network for any call. It consults the network map, decides on the idle links to be used in the path, and informs the various network frames of their parts in the connections. (Each frame completes a two-stage fragment of a connection when a call is set up.)

Information defining the crosspoints to be closed in a frame is sent over the peripheral bus unit to the network controller serving that frame. A frame is first signaled, over an enable lead, to

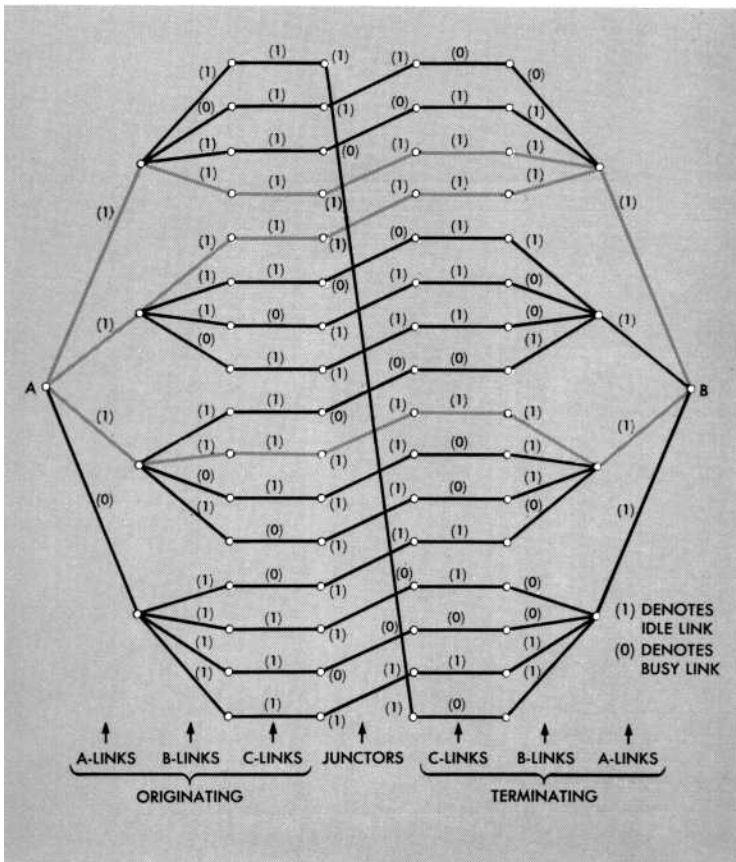

*A partial mapping of the possible paths between two lines in a No. 1 ESS office. To choose an idle path, the system consults the link memory which stores a bit for every link to represent its busy or idle status. A "1" indicates an idle link. Thus the three solid blue lines show the only three idle paths in this mapping.*

expect an order from the bus; then the actual instruction is sent. Because the bus and the network controllers are both duplicated, the enable signal defines the combination of bus and controller that will receive the instruction. There are four possible combinations; hence four enable leads serve each frame.

The controller stores the instruction data in a buffer register and uses it to close wirespring relay contacts that define a control-pulse path in the ferreed switches. After relay contact chatter stops, a high current pulse is applied to the crosspoints. The operation of the controller is checked at every stage of its internal sequence. Nineteen milliseconds after it sends an order, central control scans the outputs of two flip-flops associated with the controller. Their states indicate whether or not the order has been executed successfully.

Normally, the controllers operate independently of each other. Each can accept one order every 20 milliseconds and it controls only half of the network switches in the frame. However, if a fault is detected in either controller, an order is

sent to the healthy one giving it control of the entire frame and quarantining its mate. A follow up order cuts through sixteen observation points in the quarantined controller to a common diagnostic bus. This second order is followed by a series of test orders designed to narrow down the possible causes of the trouble. Execution of these test orders results in a printout on the teletypewriter containing an accurate clue to the fault.

The 20-millisecond control cycle of the network is dictated by the operating speed of the wire spring relays in the ferreed pulse path. This speed is sufficient for the system—a typical network controller is used only five per cent of the time during a busy hour.

The ferreed network of No. 1 ESS is a unique cross between electronic and electromechanical switching techniques. Not only does it solve the difficulties experienced by earlier all electronic networks, but it introduces a much greater flexibility to telephone switching. Three basic frame designs yield networks that efficiently span the unprecedented range of a few thousands to many tens of thousands of lines.

*Any desired pattern of interconnections between the line and trunk link network is easily made with a jack and plug arrangement at the junctor frame shown here. In electromechanical offices these interconnection patterns must be changed by rewiring*

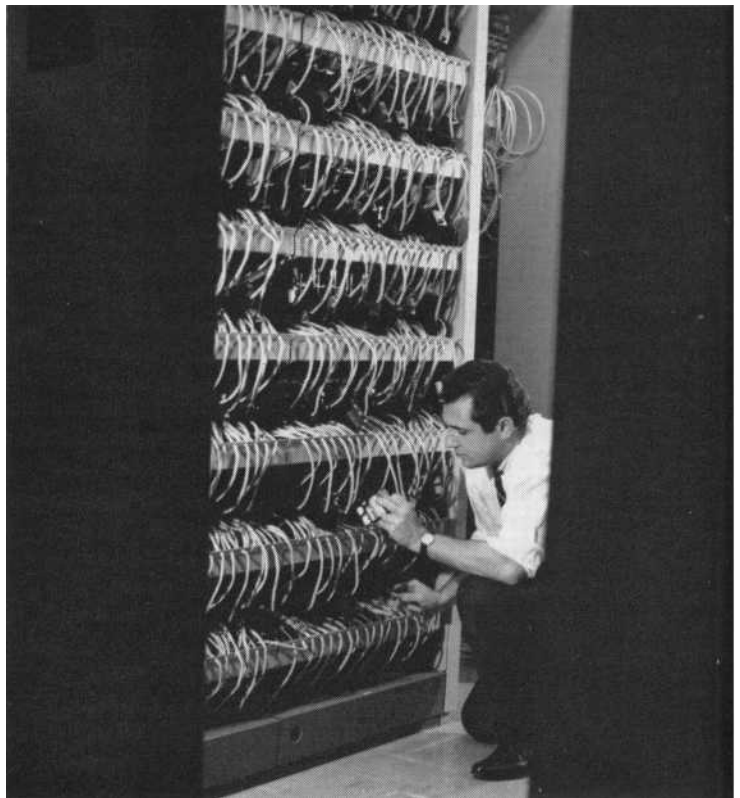



*Standardization was the keynote in the mechanical design of No. 1 ESS. The result-fewer frames and equipment options than any conventional system-means greater economy, front manufacture through installation and maintenance.*

# Mechanical Design

D. H. Wetherell

TO A CASUAL OBSERVER, one telephone central office is much like another, and a 10,000 line No. 5 crossbar office in New York is indistinguishable from one in California. But the frames of seemingly alike switching equipment often are tailored precisely to fit different traffic patterns requiring many different features and services. There are, for example, more than 125 different frames manufactured for No. 5 crossbar offices and hundreds of possible service options. Obviously, the more frames and options, the higher the manufacturing cost, and the more difficult it is to plan for change and growth. The most flexible systems are adaptable to many situations with little change in basic equipment.

The apparatus and equipment of No. 1 ESS was designed to accent the flexibility and versatility of stored program operation. Previous articles in this issue have described the great variety of features and services No. 1 ESS offers; a much greater variety than any electromechanical system. And it does this with more highly standardized equipment that occupies a smaller volume of space than the equipment of any electromechanical office having a comparable number of lines.

A new system must compete with existing ones (see *Features and Services* in this issue) both in new features and services for customers, and eco-

nomically. One important consideration, for instance, is building space. Many panel and step-by-step systems are nearing the end of their economic lives and a compact switching system such as No. 1 ESS occupies only a fraction of the floor space the older ones use. Thus older systems can give way to No. 1 ESS with only small alterations in existing telephone company buildings.

The varieties of equipment for No. 1 ESS offices and for No. 5 crossbar offices is a dramatically revealing contrast. Compared to the more than 125 types of frames for No. 5 crossbar, there are only 30 types of frames for No. 1 ESS—a 4-to-1 reduction. Wired system options are an even sharper contrast. No. 5 crossbar has more than 1200 wired options, No. 1 ESS only about 20—a reduction of about 60 to 1.

Mechanical design of No. 1 ESS ranged widely from equipment used in large quantities, such as circuit packs and ferreeds, to one-per-office equipment, such as the master control center and the card writer. We will discuss only a few representative examples in this article—the design of the frameworks which support the equipment and apparatus, and a few of the major items of apparatus.

Equipment frames are a logical beginning. The goal was frames of modular size that would be functional building blocks free of options.

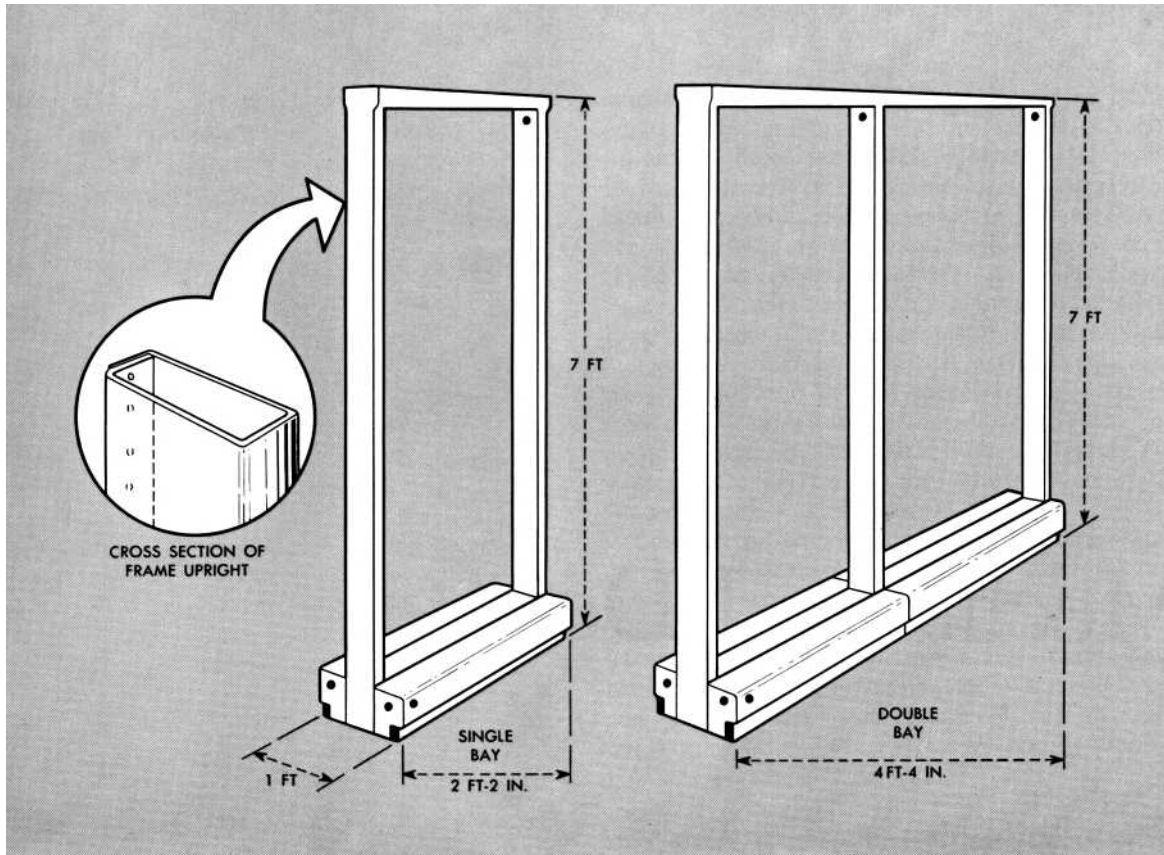

*Basic single bay frame module and double bay multiple. Sheet metal uprights centered on the base provide an 8.5-inch deep apparatus mounting space at the front and a 3.5-inch deep wiring space at the rear.*

To start with, designers could call on the long experience with electromechanical offices containing varied types of central office frames, as well as the experience of the Morris office and frames designed exclusively for an electronic system. Several basic questions were raised. First, should frames be double-sided as they were in Morris, or the more conventional kind with equipment and wiring directly accessible from the aisles? Second, should equipment and wiring be exposed, or covered? Third, how high should frames be, how wide, and how deep for No. 1 ESS equipment?

The answers to these questions were straightforward. First, the electron tubes and germanium diodes and transistors of the Morris office necessitated air conditioning. Double-sided, enclosed frames eased this problem. Also, at that time designers thought that double-sided frames saved floor space. The semiconductors of No. 1 ESS can tolerate higher temperatures and so do not require air conditioning. Besides, studies showed that double-sided frames saved little, if any, floor space. To complete the case for single-sided frames, they are less expensive to build and install and easier to test and maintain.

The standard height of No. 1 ESS frames was

set at seven feet. This height is compatible with the smaller No. 1 ESS functional units and it results in shorter leads. Short frames are maneuverable; they fit in standard elevators and through doors, easing both installation and maintenance. Also they are supported entirely from the floor and need no overhead structures. Craftsmen seldom need stools or ladders for testing or maintenance—an added safety feature.

Finally, the argument for short frames was, in part, an argument against conventional eleven foot frames. The high density of electronic equipment leads to floor loading that is as great for short frames as for tall ones stocked with electromechanical equipment. For example, the heaviest No. 1 ESS frames hold the twistor memories. A single frame of this kind weighs about 1800 pounds and covers a four and one-third by one foot area. A tall frame with such volume would exceed the floor loading limits of many existing buildings.

The advantages of short frames are partially offset by floor space considerations. Despite this, a typical No. 1 ESS switchroom requires less than one-half the space of comparable electromechanical switchrooms.

A cable rack rests on top of the frames in each lineup. Additional cross-aisle cable racks are placed just above and at right angles to these at each end of the lineup and at intermediate points when they are needed. This arrangement of racks serves a dual purpose. It simplifies cable routing and it rigidly interconnects frames and lineups, adding stability.

The basic frame module is 2-feet 2-inches wide and 12 inches deep. Frames have a variety of widths, including 2-feet 2-inches, 3-feet 3-inches, and 4-feet 4-inches. However, when frames are combined in a lineup, the combination is always a multiple of the basic module. (See the drawing on page 242.) The 2-feet 2-inch width is most common. Three circuit pack housings can be mounted adjacent to one another in the 23 and one-half inch space between uprights on this frame. It is also adequate for the larger apparatus units, such as the twistor memory, the teletype-writer, magnetic tape recorder, and card writer.

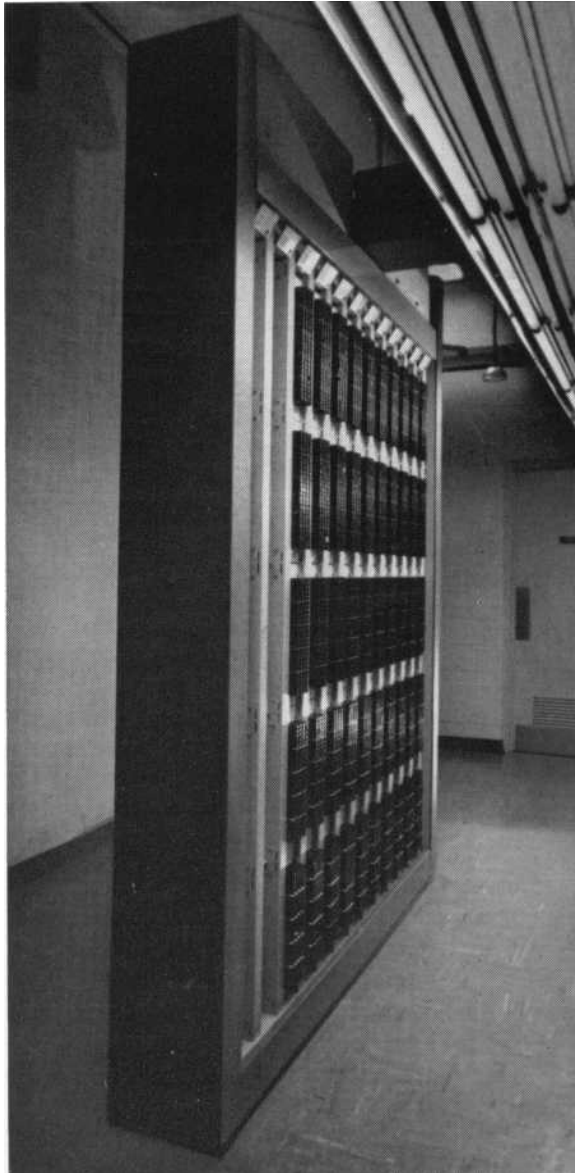

The depth of the frames was determined primarily by the size of No. 1 ESS apparatus. It also permits six rows of frames to be mounted between standard building columns with 30-inch wide maintenance aisles and 20-inch wide wiring aisles.

A main distributing frame (MDF) compatible in height and floor space areas accompanies the switching and equipment frames. Conventional MDFs are double-sided-protectors on one side, cross-connecting terminal strips on the other. No. 1 ESS has two frames—a protector frame and a cross-connection frame which is called the MDF. These frames are a further contrast between older offices and No. 1 ESS. To terminate, say 6000 conductor pairs, a conventional crossbar office requires an MDF 14-feet long. No. 1 ESS terminates the same number of pairs on an MDF only 6-feet 6-inches long.

MDF terminals are arranged in columns, 1200 pairs of terminals to a column. Connections are



*Central office equipment can be disconnected from the protector frame merely by pulling the protector forward to a detent position. This action disconnects only the central office equipment and not the outside cable pair which remains protected.*

*The protector frame guards system circuits against lightning and other high voltages. Protector units also serve tip and ring conductors of a cable pair. White blocks between the groups of protectors in each vertical column are test points.*

made to these solderless, quick-connect type of terminals by forcing the insulated wire into a tight-fitting tapered slot. (See the drawing and photograph below.) The terminal cuts through the wire insulation and its spring-action grips the wire firmly.

A new kind of plug-in protector unit on the protector frame houses the carbon blocks for tip and ring circuits. The frame has 12 verticals each containing five panels that, in turn, each mount 100 protector units—a total of 6000 units per frame. At the back of the frame they connect to outside plant cables and tie cables to the MDF.

The equipment frame design could not be "frozen" until the designs of all equipment units and apparatus were well established. Some of the pertinent factors in this design were the packaging of semiconductor circuits, the ferrite sheet and twistor memories, the ferreed switches, the ferrod sensors for scanners, and the design of such components as AMA recorders and the teletypewriter to fit the new traffic and maintenance record concepts of No. 1 ESS. The remainder of this article will discuss some of these components and their mechanical design.

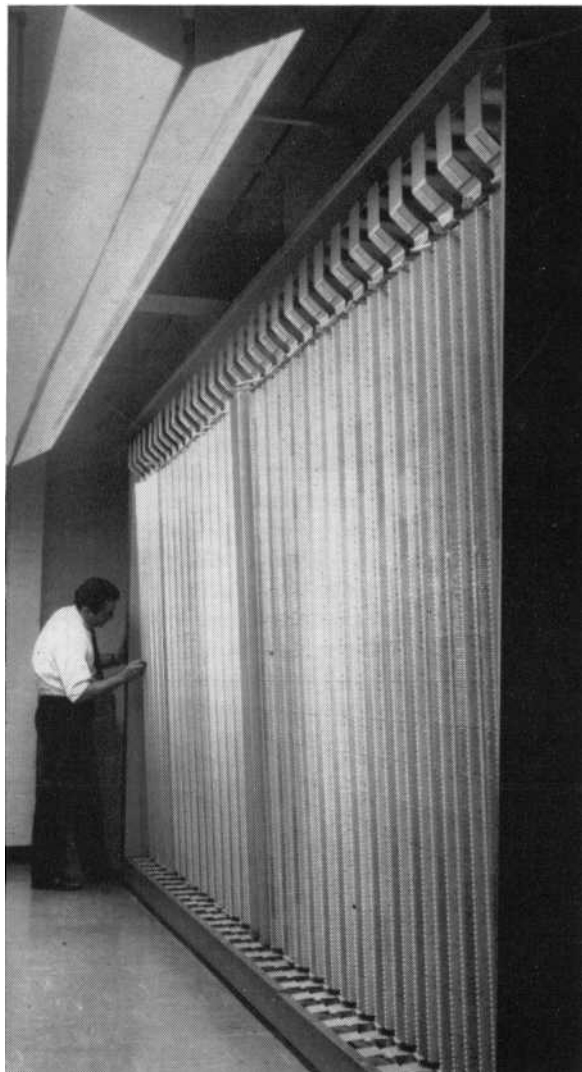

Semiconductors are mounted on printed circuit packs which are plugged into molded wire spring connectors mounted in die-cast aluminum housings. One circuit pack can hold about 70 typical components. The actual number may vary from as few as six relatively large components to as many as 84 small components such as resistors, capacitors, and transistors.

Printed wire paths on the circuit pack phenol fiber board are gold plated at one end forming 28 connector terminals. The size of the packs and the number of terminals reflect both the experience of the Morris office and compromises among such factors as the total number of contacts needed for the system, lead lengths, cost, and the number of circuit pack types required.

The ferreed switch is the crosspoint element of the No. 1 ESS network. It consists of two small sealed-reed switches operated and released by controlling the magnetization of two adjacent remendur plates. (The story of the development of remendur, together with a description of its magnetic properties, is told in *Some Magnetic Materials* in this issue.) Shop wiring runs on the rear of the frame to terminals on the back of the

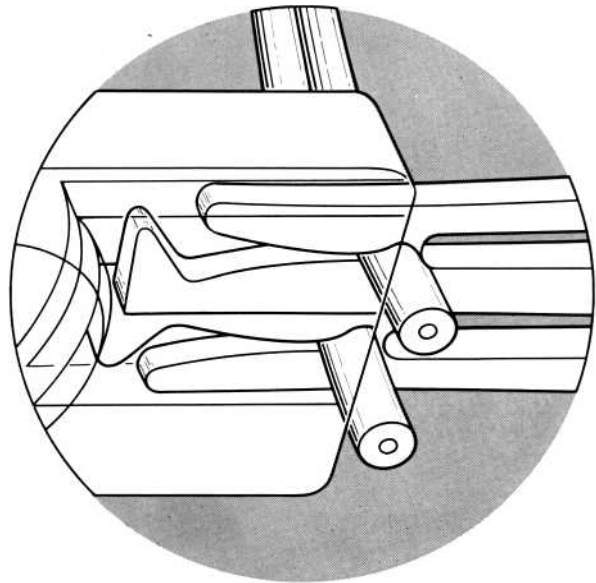

*'Quick-connect' block on distributing frame speeds up making cross connections. Craftsman merely holds insulated wire in the slot opening of the terminal clip and forces it into place with a hand tool.*

*In many large central offices, the length of the main distributing frame (MDF) determines the length of the building. The MDF of No. 1 ESS, shown here, is three-quarters the height and requires only one-third to one-half the floor space of large distributing frames in conventional offices.*

switch. Installation wiring runs to another set of terminals on the front of the switch. Thus the installer can work in the wider equipment aisles and not interfere with shop wiring.

The system may use four types of these two-wire switches. The first, the most common, is an 8-by-8 array of crosspoints. The second comprises two 8-by-4 arrays. The third, called a 16-by-4 out of 8 array gives 16 lines access to eight links, but each line access to only four of the eight. The fourth type comprises four 4-by-4 arrays. There are also two types of bipolar ferreeds, one a 1-by-8 and the other, eight individual cross points.

The ferrod sensor (see page 209 of *From Morris to Succasunna* in this issue) is the building block of all No. 1 ESS scanners. To conserve mounting space, a ferrod sensor contains two ferrods in tandem. Their "egg crate" apparatus mountings accommodate 128 dual units. The mounting is not only a physical support, but serves as an array of magnetic shields preventing interference between adjacent sensors.

The operation of the program store twistor memory is described in *Memory Devices* in this issue. The 64 twistor planes of the memory module are mounted vertically in an aluminum and steel framework. Each plane is made of stable glass-bonded mica with solenoid tapes and twistor tapes cemented to each side. Resilient springs hold the memory cards in close contact with the twistor tapes.

To change information on a twistor card is a matter of magnetizing or demagnetizing its vic-alloy magnets. This is done with a memory card writer. A complete complement of 128 cards is removed from a program store memory module with a card loader and transferred to the card writer. To permit safe handling of the card loader, both the program store and the card writer frames require a maintenance aisle at least four feet wide.

Since cards are stacked in the module back-to-back, and removed in this same position, two passes through the card writer are necessary when changing memory information. The first pass writes those 64 cards with magnets facing in one direction; the second pass writes the other 64 cards.

As the writing head passes over the length of a card it magnetizes initializing magnets, senses their location, and writes each bit of each word in passing. Because the initializing magnets are used for position sensing there are few critical mechanical tolerances in longitudinal card and head positions. After the writing pass, the card is automatically reinserted in the card loader.

The box-shaped card loader supports the cards

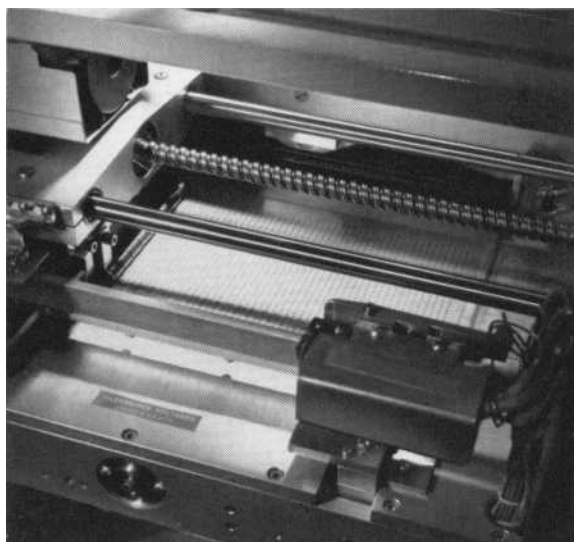

*Card writer with a twistor memory card in position. Tops of other cards held in the card loader, can be seen just above the spiral shaft. The roller at the left holds the card writing head at a precise distance above the surfaces of the magnets.*

in the same relative position they occupy in the memory module. When cards are removed from the module, they are engaged by pins on individual finger-like actuators whose pointed tips are inserted between pairs of cards in the wide spaces opposite the twistor planes. The actuators rotate in unison causing small transverse pins to enter openings in the cards as needed to extract the cards from the modules.

The insertion force on each card is limited to between four and six pounds. Individual pre-tensioned springs control this force and an interlock stops the drive motor if the force exceeds the upper limit. This assures that all cards seat properly and protects the memory from damage if a card jams or sticks. Since all cards are inserted simultaneously, the loader's total seating force is 500 to 800 pounds.

These designs, along with the designs of much other equipment and apparatus were based on two decisions which had to be made simultaneously. First, circuit configurations were considered in terms of all the system functions and reduced to the fewest possible number. Second, many ways of packaging each device were studied and compatible designs were selected. On the basis of these decisions, the variables needed for a particular functional frame could be selected from a catalog containing a minimum of different apparatus and framework types. The goal throughout the development of No. 1 ESS was to achieve a modular design that would be most economical to engineer, manufacture, install, operate, maintain, and administer. The apparatus and equipment are a giant step forward in combining versatility and flexibility with standardization.

*No. 1 ESS power plants are much simpler and more economical than those used in the Morris office. Succasunna, however, introduces an entirely new idea in its use of precision dial tones and call progress tones.*

# Power System and Ringing and Tone Plants

J. W. Osmun and J. R. Montana

IN the four years between the trial of the electronic central office in Morris, Illinois and the opening of the first No. 1 ESS office at Succasunna, New Jersey the design of solid state devices took a giant step from a very promising art to a well rounded technology. The transition had a marked effect on the power supply plant and on the ringing and tone plant of No. 1 ESS. In the former it led to a greater simplicity and economy, in the latter to a new philosophy of precision dial tone and call progress tones.

Refinements in the power supply plant were the result of changes in the electronic system rather than a matter of new concepts in the design of power systems. The Morris office used a great variety of devices-transistors, semiconductor diodes, gas tubes, electron beam tubes, relays. They required a total of about 80 separate and precise voltage levels. Furthermore, the gas tube switching network of that office could not switch 20-cycle ac ringing current, and so it was not

compatible with existing customer telephone sets.

In Succasunna, on the other hand, gas tubes and electron tubes have been eliminated and the requirement for precise multilevel power has gone with them. In addition, the ferreed network was designed to transmit do as well as voice frequency signals. These changes allow No. 1 ESS to operate within voltage limits that are even wider than those required in electro-mechanical systems. It is designed to use two voltage levels, +24 volts and -48 volts, and it can tolerate swings of approximately 10 per cent above or below either level. The power is supplied by two common battery power plants that are protected against commercial power failure by a standby engine alternator.

In its use of precision tones, No. 1 ESS is unique among telephone central offices. An office requires four fundamental tones - TOUCH-TONE® dial tone, audible ringing tone, high tone, and low tone. High tone is a single frequency,

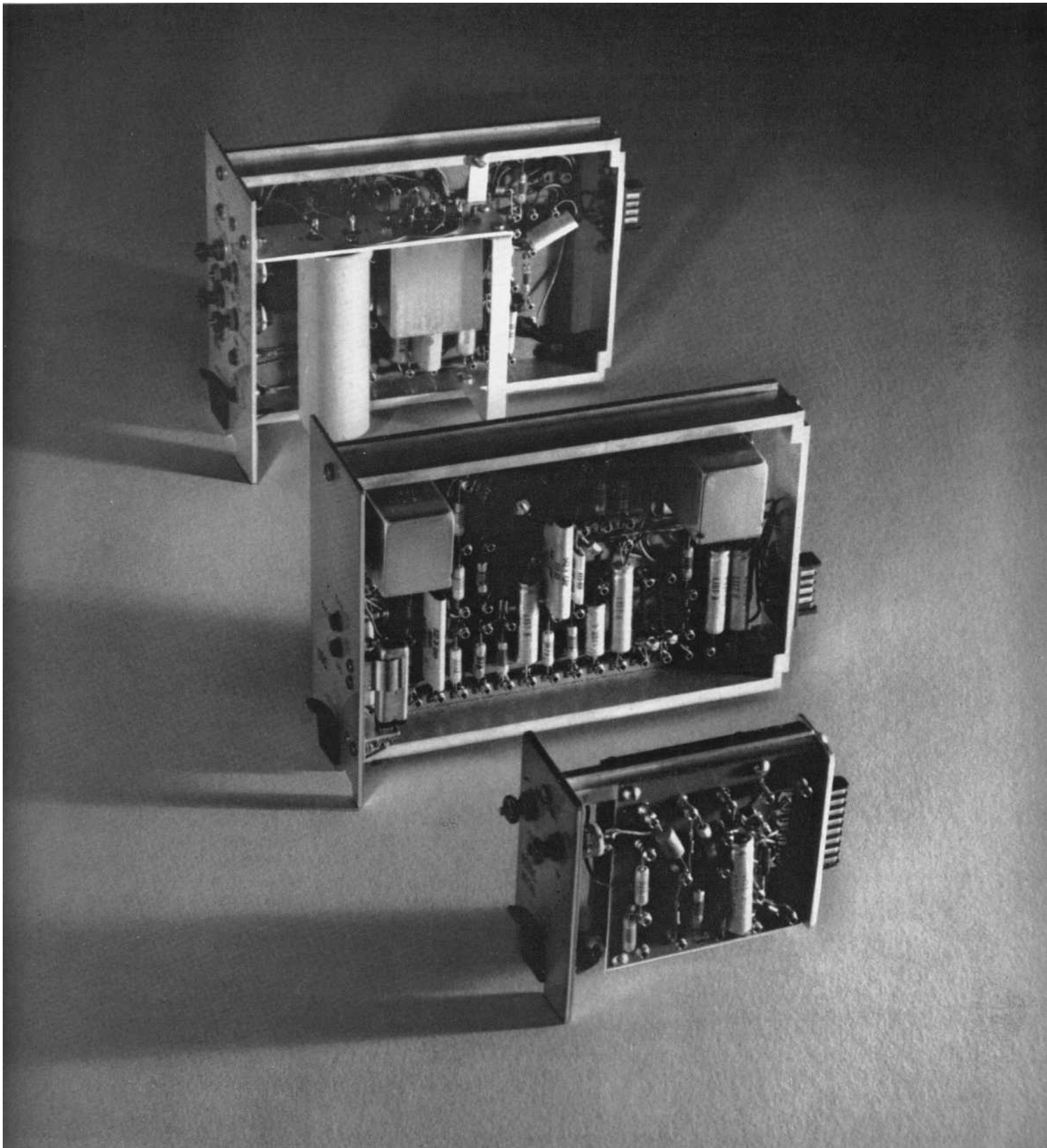

*Tone amplifier, tone oscillator, and tone monitor (top to bottom) of No. 1 ESS tone plants.*

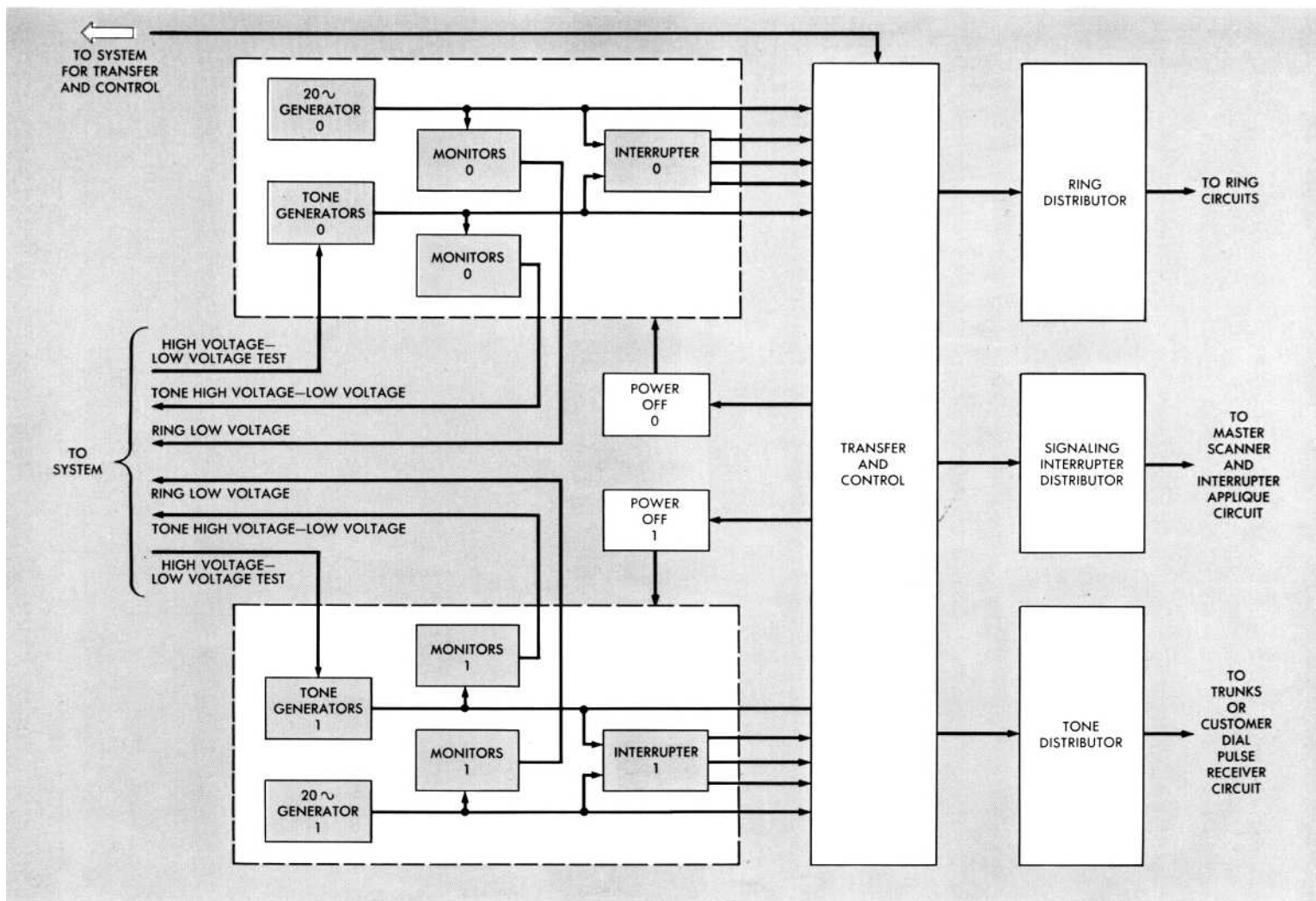

*Block diagram of a typical No. 1 ESS ringing and tone plant.*

the others are mixtures of two separate frequencies. The four component frequencies from which the mixtures are selected (see the table on page 249) are generated as pure sinusoidal signals in transistor oscillators and are added together and amplified by transistor feedback amplifiers. (The drawing on page 249 shows the waveforms generated by the amplifiers.) Each oscillator contains tuned reed selectors, much like those used in the BELLBOY signaling system, (RECORD, September, 1964), that select the basic frequencies within 0.5 percent. The actual output of the oscillators, a square wave, is converted by bandpass filters to a sine wave with a harmonic level 60 db down from the basic frequencies.

Audible ringing tone also is generated as a combination of two precision tones. In conventional central offices, audible tone is superimposed on inaudible 20-cycle ringing power and it is interrupted and distributed from the ringing plant. In these offices the two tones often are generated simultaneously. In No. 1 ESS, 20-cycle ringing is generated in one set of generators, and audible

ringing is generated and interrupted in a separate set. Audible ringing tone is distributed within the office and applied to loop and trunk circuits in the same manner as all other tones.

Continuous outputs from the generators and all outputs from the interrupters are fed to a transfer and control circuit which then directs the various tones to appropriate distribution circuits. Both continuous and interrupted ringing signals for ac-dc, and superimposed ringing are fed to these panels. All signaling interruptions -30, 60, and 120 interruptions per minute-are sent to the network via an applique circuit. All tones are routed from output transformers through splitting resistors to furnish a balanced output.

No. 1 ESS is the only system in operation with signaling plants designed on the philosophy of precision tones. The plants used in No. 1 ESS are not compatible with other systems. However, their expected performance makes it safe to consider ESS as a pioneer in a technique that will



be adapted to other large switching systems. There are four primary advantages. First, in present switching systems, signaling techniques require rather wideband receivers at the distant termination of loops and trunks. No. 1 ESS signaling is received within a much narrower range than is possible in conventional systems. Second, low loss which is a vital factor in interoffice trunking gives rise to stringent return loss requirements. The No. 1 ESS signaling system easily meets them. Third, the precise nature of No. 1 ESS tones result in even less noise and crosstalk than occurs in conventional systems. Finally, the controlled harmonic content of the signals permits machine recognition of tones, a capability that may lead to new features. Apropos of this, the precision tones will not interact with other apparatus that is actuated by tones, such as TOUCH-TONE receivers. Each device functions only on an exact tone.

The drawing on page 248 shows the layout of a typical No. 1 ESS ringing and tone plant with its duplicate ringing generators, tone generators, and interruptors. Thus each office has essentially two plants, one always in operation the other in reserve. One plant is called the 0 side, the other is called the 1 side. The generators on both sides of the plant are supplied with power. However, to reduce gear and contact wear in the interruptors, only the working one is supplied with power. Although the program selects the generator that actually transmits signaling tones to the office, a manual switch can supersede this control if routine maintenance or an emergency requires a change from the working to the reserve side of the plant.

Readers of previous articles in this issue will recognize that the provision of duplicate plants stems from the No. 1 ESS requirements for reliability. They will also expect programmed maintenance of the plants. Since precision tones require a precise voltage supply, the output of the

TONES	FREQUENCIES (cps)
TOUCH-TONE	350 + 440
Audible Ringing	440 + 480
High Tone	480
Low Tone	480 + 620
Line Busy Tone	Low Tone at 60 ipm
Paths ("fast") Busy Tone	Low Tone at 120 ipm

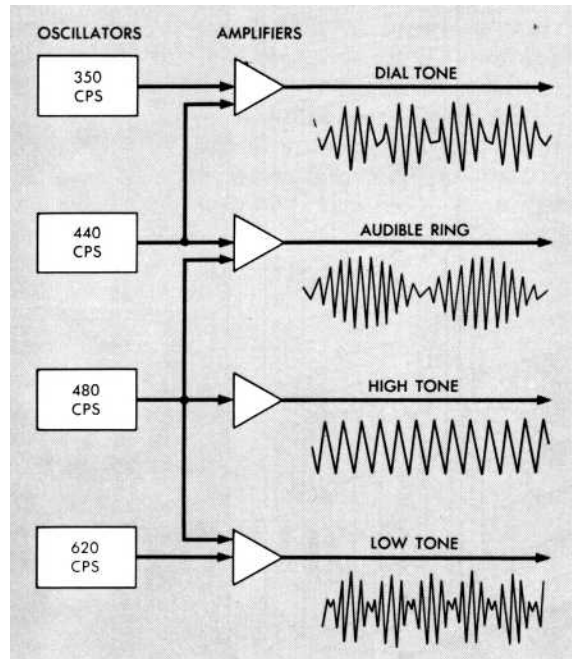

*The four basic frequency components of No. 1 ESS ringing and tone signals and the waveforms generated by the transistor amplifiers when the basic frequencies are mixed to form the tones.*

working generators are monitored, and error signals are fed to the master scanner if the output level varies beyond acceptable limits. Thus the system is informed if a generator malfunctions and can order a switch to the reserve side of the plant. To check the operation of the monitors themselves, maintenance programs switch the tone generators from normal to high voltage or to low, and then check the monitors to see if they detect the change. Various outputs of the ringing generators also are monitored. Unlike the tone generators, however, ringing generators do not fail marginally. Therefore, to check the ringing generator monitors, the system merely shuts off power to the generators.

Two sizes of ringing and tone plants have been designed to accommodate small or large offices. A third, intermediate, size is underway for the future. At present, the 806H Plant, which has a ringing capacity of 0.5 ampere, is used for smaller offices like Succasunna. For large offices, there is the 808A Plant which has 6-ampere transistor generators. These large generators were recently designed to operate from -48 volt battery supply so that they will not be affected by any possible ac power failure. The intermediate sized plant will be rated at about 1.5 amperes. The tone generators are designed to supply the largest office and are the

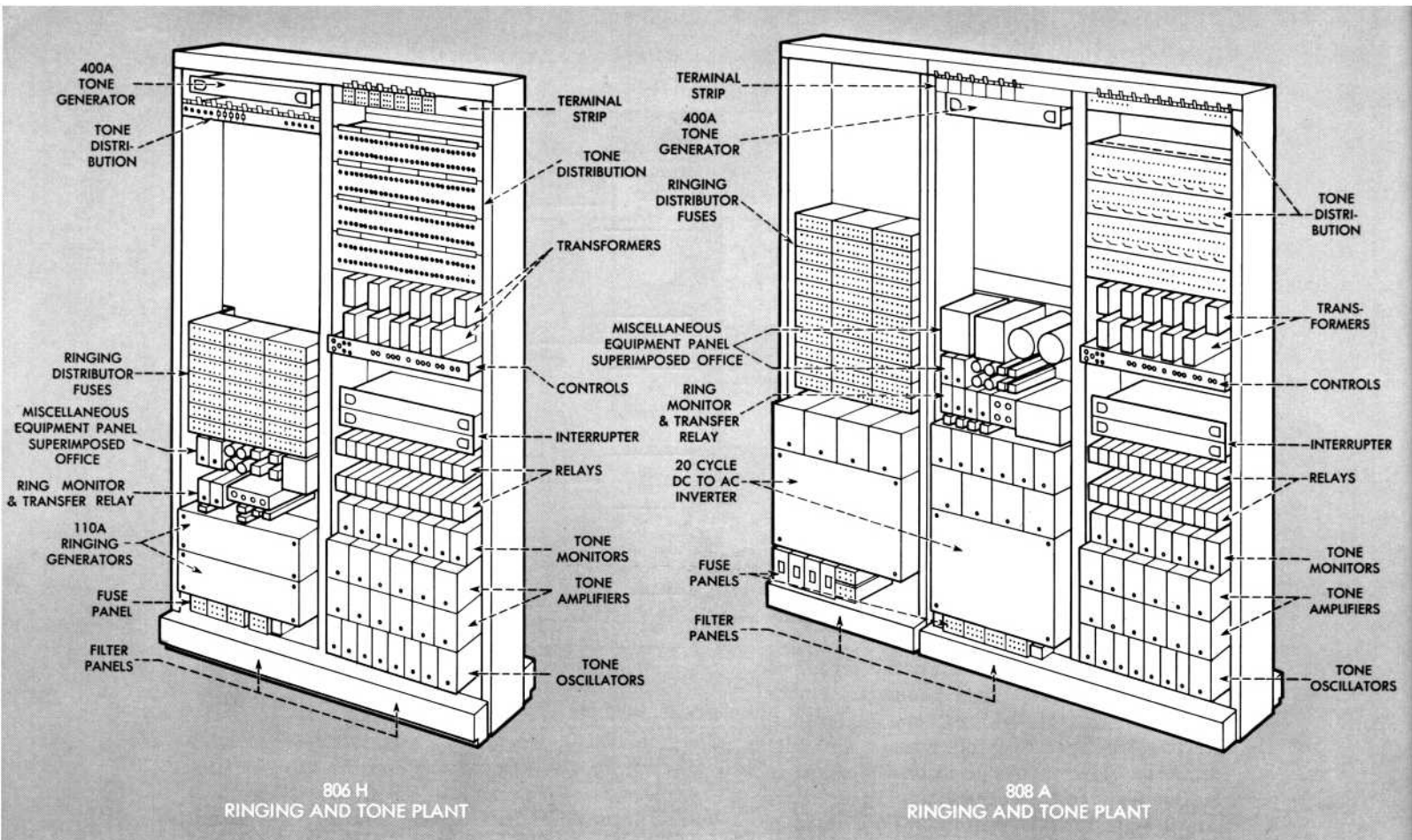

*Equipment arrangements of the small and large ringing and tone plants. The tone bay is the right panel in each framework, the ringing bay is the left panel. The empty areas in each plant are reserved for the additional ringing fuses and tone splitting resistance panels, added as an office grows.*

same in all offices.

In the present plants, interrupters are motor-driven cam and spring machines. Special timing pulses transmitted from the plant to central control inform the system about the state of the machine ringing brushes so the system can select the proper brush and deliver "immediate ringing" to a called telephone. Code ringing is generated in the connecting ringing circuits.

Except for the small rotary interrupter, the ringing and tone plants are entirely solid state. In fact, to handle the larger currents that must be interrupted in large offices, solid state devices are used as interrupter followers in the ringing part of 808A Plant. Fully solid state interrupters are planned for use in future No. 1 ESS offices. A feature of these interrupters is all-transistor timing circuits that are synchronized with the 20 cps signal. All the interrupting switches also will be solid state devices.

As the drawings on this page show, much of the equipment in the ringing and tone plants is panel mounted on standard No. 1 ESS frame-

works. The extensive use of solid state devices lends itself to the plug-in module type of construction for most of the circuits, and this results in a very efficient use of space on the frames and convenience in maintenance. Unlike electro-mechanical systems which require ringing distribution fuse panels and tone distribution panels in many parts of the office, No. 1 ESS ringing and tone distribution is confined to the ringing plant itself. The equipment is arranged on the framework in a way that allows additional circuits to be added quite simply.

The power, ringing, and tone plants were designed to meet the complex requirements of an electronic switching system. In general, they meet them economically. Solid state circuits have the high reliability and easy maintenance that generally accompanies this design technology. In step with other major subsystems of No. 1 ESS, the ringing and tone plant presents a new philosophy of telephone system design with the traditional reliability that is always demanded of a telephone switching system.

*Concentration of control into one central processor and the complexity and speed of No. 1 ESS circuits make new demands on maintainability and dependability. The system must detect and recover from troubles almost instantaneously and must do much of its own trouble analysis.*

# A New Approach To System Maintenance

R. L. Campbell & W. Thomis

**A** BASIC PREMISE in the philosophy of maintenance for No. 1 ESS is that the machine itself can and should locate faulty components almost automatically. This singular idea emphasizes the power of stored program control—the program is the major instrument of maintenance. But, though it is a new departure in telephone switching systems, programmed maintenance is only one of many factors making the maintenance scheme of No. 1 ESS unique in telephone systems. Another significant consideration is the intense concentration of system control into one central control unit.

In a No. 5 crossbar office, control is concentrated in the marker, but a large office may have many markers. If one, or a number, stop operating, calls are directed to the remaining ones and, from a customer's point of view at least, the office still gives largely satisfactory service. But in a No. 1 ESS office, control is concentrated in one of only two central controls. If one fails, it must be repaired immediately, for if the duplicate unit also fails, no calls can be processed. Thus the road to dependability in No. 1 ESS runs through relatively new terrain.

Like any telephone system, No. 1 ESS must be

dependable, servicing telephone calls continuously and accurately even in the face of trouble. And it must be maintainable. This means that the system must be designed so that faulty components can be located and replaced rapidly and economically.

Reliable components are essential to dependability. No. 1 ESS semiconductors are all silicon devices, unqualifiedly more reliable than the germanium devices of the Morris trial. Epitaxial processing techniques, invented at Bell Laboratories, also add to their life. Furthermore, the magnetic materials fundamental to many devices are processed with careful control to produce high stability. These measures, described in other articles in this issue (See *Semiconductors* and *Some Magnetic Materials*) produce only a tolerable rate of failures, however. The vast number of components in No. 1 ESS (hundreds of thousands of semiconductors, for instance) average about one failure every few days. The system maintenance plan must cope with these component failures so the system continues to give accurate, uninterrupted telephone service despite the trouble.

A basic element of the maintenance plan for No. 1 ESS, is the duplication of all major subsystems. If one fails, its twin takes over. In essence,

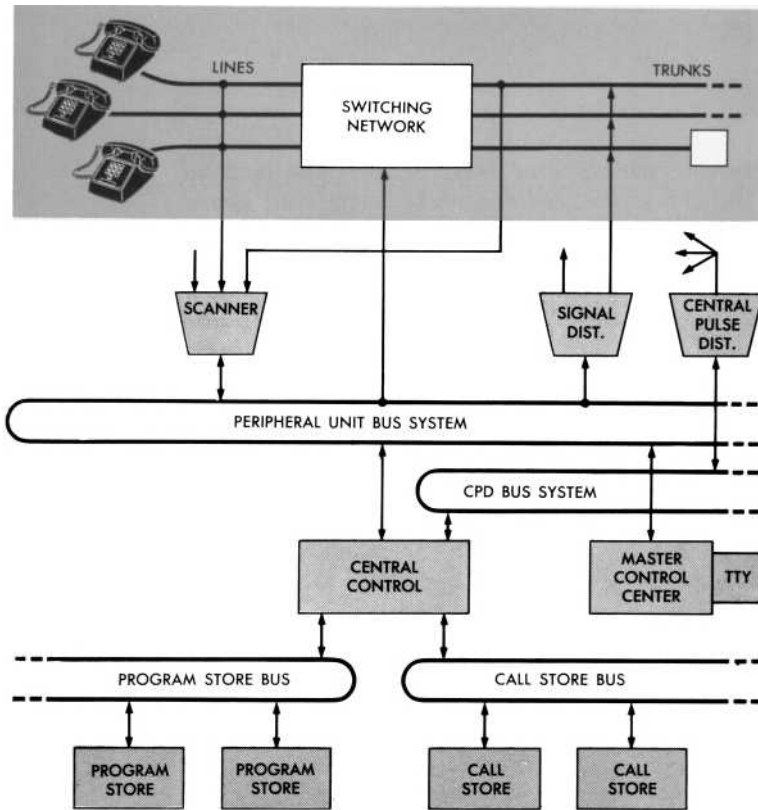

*To process any call in No. 1 ESS, a chain of units must be operating properly. The links in the chain are units drawn from various subsystem communities. Each subsystem community is a duplicate of the others—the central control community consists of two units, the program store community of two to six units, etc. A failure in any one link in the chain temporarily interrupts system operation. Interruptions, when they occur, are very short; the system can switch between duplicate units within subsystem communities in a period about equal to only one machine cycle.*

this creates the possibility of many systems, or rather of one system with a multiplicity of possible arrangements. If a subsystem fails, the system reorganizes itself around the duplicate and continues to process calls.

Special maintenance programs and circuits direct this reorganization or "recovery." Subsystems are grouped according to type (e.g. central control, call store) and each group is called a subsystem community. (See the drawing on this page.) Generally speaking, a special recovery program governs each community. If a failure disrupts the community, the program surveys it, determines which subsystems are operable, and interconnects them to provide a functionally complete community.

Recovery programs must fulfill some rigorous requirements. First, because even a single trouble may interfere extensively with normal, often basic, machine operations, the recovery programs must be highly flexible in their use of equipment. (The programs are complemented by special backup switching circuitry so that the recovery process

never relies exclusively upon any particular item of equipment.) Second, these programs must decide unerringly which subsystems are operable even when there are multiple troubles or inconsistent or contradictory indications of trouble. And they must do this in a matter of milliseconds or risk undermining the accuracy of call processing. During recovery, all call programs are suspended. However, some, such as dial pulse scanning programs, which are scheduled every few milliseconds, cannot be deferred or calls will go astray. (See *The Stored Program* in this issue.) Therefore, recovery programs must accomplish their mission between two clicks of a telephone dial, so to speak.

Accuracy depends largely on the system's ability to detect the *presence* of any trouble before it can interrupt service to telephone customers. Several trouble detection techniques are employed in the system.

- Duplicate equipment operates in parallel. Both central controls, for instance, receive all data on all calls in the system, although only one directs the actual connections. Key points in each are matched to see if the two are operating identically.
- Special checking circuits are built into subsystems to detect operating anomalies.
- Information between subsystems is redundantly encoded and special circuitry checks the consistency of received information. This allows detection of errors in transmission as well as troubles in the sending unit.
- Subsystem equipment that is infrequently used in the normal business of the system is routinely exercised at regular intervals to check its condition.
- Call programs are designed to recognize incorrect or invalid system responses to call processing operations and report them.

The first three of these techniques use maintenance circuits to detect troubles; the others use the programs' trouble-detecting capabilities. If the circuits detect trouble, they create a high-level interrupt and pass control to the recovery programs which then isolate the trouble. If programs encounter trouble indications, they call in recovery programs immediately.

All these features have one end in view—dependability; and No. 1 ESS is expected to set a new standard of dependability for large electronic systems. This, however, is only half the battle. The rest, maintainability, is fought by "trouble qualification" and "diagnostic" programs.

Conceptually, trouble qualification programs

begin where recovery programs end. (Actually, the two often overlap.) These programs survey a stricken community, identify and isolate faulty subsystems, and restore to service subsystems that the recovery programs may have temporarily quarantined. If the recovery program has determined that the trouble will not interfere with normal call processing, trouble qualification may be done in the system's "spare" (excess) time. Or, as an alternative, trouble qualification may be done during recovery. (This is the point at which the two often overlap.) Most No. 1 ESS subsystems may be treated either way depending on the nature of the trouble and the prevailing conditions when it is detected.

Some component failures create erratic or non-reproducible trouble symptoms which the trouble qualification programs tend to classify as transient errors. In this case, the programs may certify faulty equipment as trouble-free and return it to service. Too many misinterpretations of this sort could lead to disaster. Therefore, the trouble qualification programs are designed to recognize excessive "transient errors" and to identify and isolate the subsystem they emanate from.

Diagnostic programs are quite specific, each designed to analyze troubles in a particular subsystem. They test the subsystem exhaustively, process the results, and identify the fault by a trouble number. The system teletypewriter prints out the number and maintenance personnel merely look it up in a "fault dictionary" which directs them to the physical location of the faulty plug-in circuit package. Since almost all No. 1 ESS circuits are mounted on plug-in packages, repair generally consists of replacing one or two packages.

In brief, then, a cycle of maintenance begins with the detection of a trouble, and proceeds through qualification and diagnosis to correction or repair. This is the general procedure in all the subsystem communities of No. 1 ESS. However, certain communities lend themselves particularly well to a discussion of a specific phase of the cycle. The program store community is a good example of the use of trouble detection facilities. The call store community furnishes a clear picture of recovery and trouble qualification techniques. And the central control, with its thousands of circuit packages, strikingly emphasizes the advantage of automatic diagnostics. Accordingly, we will discuss each phase of the maintenance cycle in terms of those particular subsystem communities.

Trouble detection circuits serving the program store must detect the existence of a trouble before it affects call processing. This is tantamount to detecting many store troubles almost at their in-

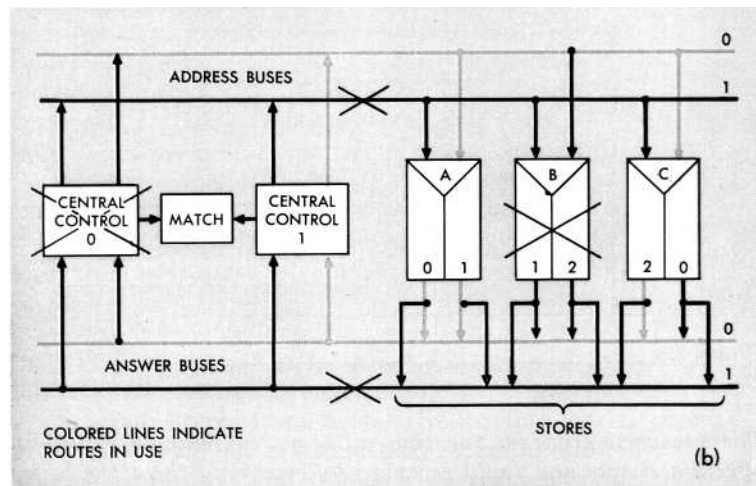
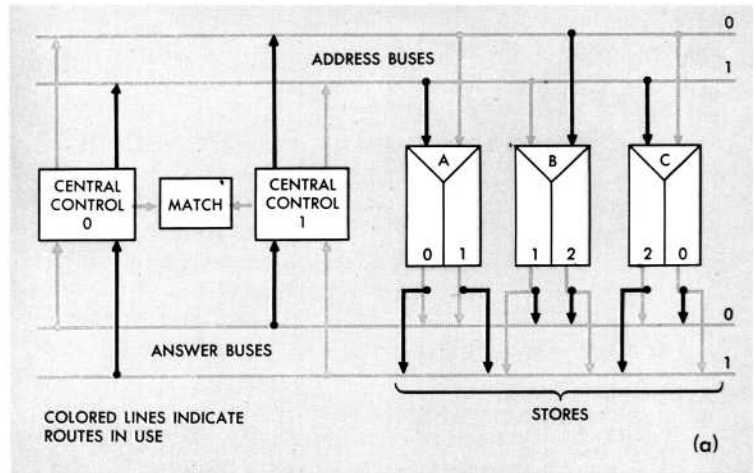

*Possible routes between the three program stores and the central controls of a system via the buses. Blue lines are the actual connections, black lines are possible routes not being used. At the top is a normal configuration with address and readout routing. Each central control uses different routes to a store. An operating configuration can always be established as long as one copy of all the information in the stores is available along with one bus and one central control. For example, if central control 0, store B and bus 1, stopped operating (crossed-out units on bottom drawing) an operating system would be possible in a new system configuration involving central control 1, stores A and C, and bus 0.*

ception. For example, some troubles can change data read out of the program store into an irrational instruction. If central control were to act upon the garbled information, it could conceivably interrupt service on all calls in the office. To prevent such a catastrophe, almost all the trouble detection techniques we have outlined are applied to the program store community.

First, there is considerable duplication of equipment. Specifically, all the information in the program store is duplicated and the duplicate stores are individually connected to the central control by duplicate communication buses, creating two separate but parallel equipment loops. (See the

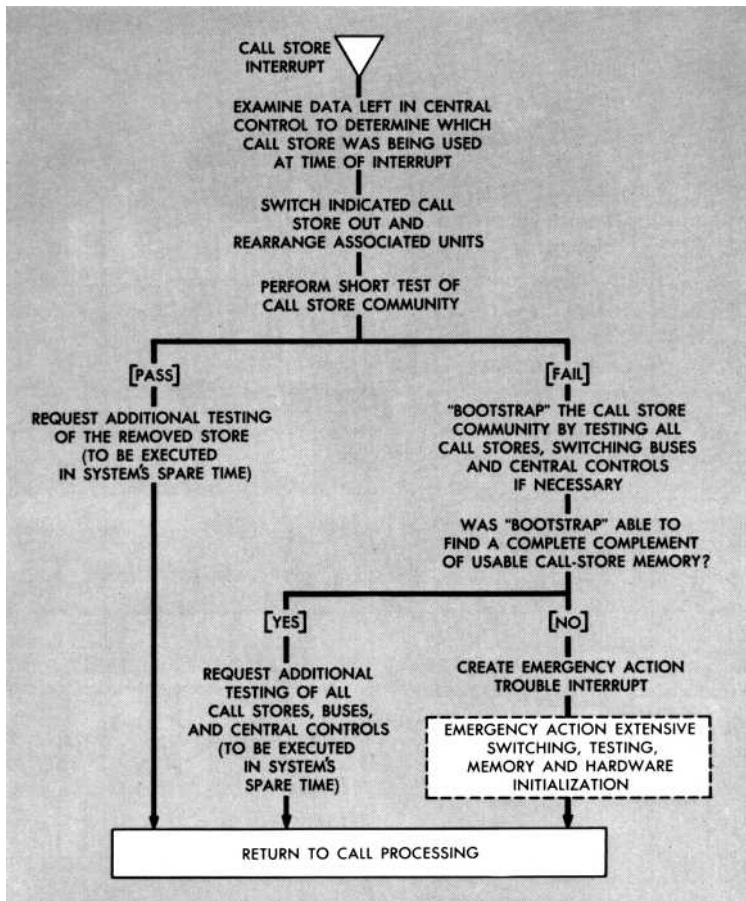

*The recovery program for the call store community generally effects a simple and rapid recovery by removing the store being used at the time of an interrupt from service. A small percentage of troubles require considerable testing of equipment. But, re-initialization of the memory and hardware (i.e. returning them to an initial processing state) is required only in very rare cases.*

drawings on page 253.) Second, there are special trouble detection circuits. Each store internally checks itself in a number of ways every time it fetches information for central control. If the results of the checks are all affirmative, the store generates an "All Seems Well" (ASW) pulse along with the read out information. Special central control maintenance circuits initiate a re-read if the pulse is missing, and order a trouble interrupt if the second reading also lacks the ASW pulse.

A third specific trouble detection mechanism is redundant coding of the information transmitted between the stores and the central control. Each word in the program store contains seven check bits in a Hamming code designed so that central control can detect and correct any single error in a data word or detect any single or double error in the program word and its memory address. If there is an error in the address or if there is a double error in the word, central con-

trol rereads the memory. A single error in the program word is acceptable in the second reading. Anything else causes a trouble interrupt.

These specific trouble detection mechanisms are backed-up by the central control matching feature. Certain troubles may escape detection by the store check circuits or the central control Hamming check circuit. In this event, there will be differences in the data read from two program stores (assuming only one is faulty) producing a central control mismatch which, in turn, generates a trouble interrupt.

Some program store troubles do not hinder the normal operation of the store. For example, a store may always send an ASW pulse no matter what the internal checks show. Troubles of this nature are detected by routine tests which are scheduled frequently enough so that there is only a negligible chance that two or more faults will occur in a store between tests.

Many of the trouble detection circuits in the call store community are similar to those associated with the program store. Troubles in the call store immediately create a system interrupt and the call store recovery program takes control. (See the drawing at left.)

Because the call store memory itself cannot be used, the program starts by analyzing certain clues left in central control, including the address at which trouble was detected and summary information on the nature of the trouble. On the basis of these clues, the recovery program determines which call store caused the interrupt, removes it from service, and switches-in the neighboring stores as temporary memory for both central controls. It then cursorily tests the reorganized memory and, if it passes, ends the interrupt. Recovery completed, the system returns to call processing.

The large majority of call store trouble interrupts are caused by straightforward faults which can be rapidly and accurately handled by this approach. Some troubles, however, are less tractable. For example, a fault in the bus rather than in the call store causes failure of the final, cursory, test. The recovery program then initiates exhaustive testing to find enough operable units for the necessary complement of call-store memory. This could involve switching of call stores, buses, and central controls. If even this extensive switching and testing fails to establish a workable organization of units, the program starts an Emergency Action trouble interrupt. Recovery at this stage may involve switching and testing all types of system equipment. However, such emergencies are rare events with the highly reliable components of No. 1 ESS.

After the "new" or reconfigured system begins service, a trouble qualification program is called in to identify all the faulty subsystems in the affected call store community. This program is sandwiched in between call processing programs whenever it will not interfere with the urgent business of processing telephone calls. In general, it has two possible courses.

- *If the system reorganized itself along a normal, rapid recovery path* the qualification program conducts a test which determines whether the root of the trouble is an actual fault or a transient error. An actual fault is handled by diagnostic programs. A transient error leads to the examination of error records, and possibly additional qualification procedures.
- *If the system reorganized itself along an unusual recovery path* the qualification program tests all call stores, both buses, and all the central control equipment associated with them. The results of these tests identify the faulty units. Diagnostic programs, executed later, actually pinpoint the fault.

Thus the recovery programs are designed to rapidly recover the system's call processing ability while the qualification programs may work at greater leisure to identify faulty units.

Diagnostic programs perform exhaustive tests on a subsystem, attempting to isolate any single fault to within one or two circuit packages. Central control, which abounds in these packages, relies strongly on automatic diagnostic techniques. Because the recovery programs can identify a faulty central control and force it into standby status, the active central control can be used to test the standby. The complete duplication of the two, their synchronized operation, and the match circuits that directly compare twin points all enter into this testing.

Diagnostic testing consists of asking the machine a series of questions with known responses. A wrong answer indicates a group of possible troubles and the intersection of all groups uncovered by the diagnosis is the actual trouble spot. The questions, of course, are asked in binary language. The answers are simple binary zeroes or ones. For example, a question might be: Can this flip-flop be set? The answer is yes or no-zero or one. The output of a diagnosis is a long string of bits, and ideally each possible fault produces a unique pattern of bits.

Diagnostic tests proceed sequentially through

different areas of central control hardware. Each test is run simultaneously on both machines and twin critical points in each are compared via the match circuits. A match means success; a mismatch, failure. The sequence of tests begins with the power and clock circuits and may run through 28 areas of central control. In general, if a test uncovers a failure in a specific area, the diagnosis is terminated.

The final phase in the maintenance cycle-repair -begins with the interpretation of the diagnostic program output. The machine itself takes the first step. A diagnostic output is generally a huge binary number, quite difficult to work with. (The central control diagnostic result, for example, contains 5000 bits.) Therefore, the system processes this result and presents the craftsman with a small decimal number. This can be done because the binary result actually contains a relatively small amount of information compared to what could be contained in a 5000 bit code.

A trouble locating manual is the craftsman's primary tool for translating diagnostic printouts into specific trouble identifications. Data for this manual was produced on the No. 1 ESS system at the Holmdel Laboratory by deliberately inserting every possible type of catastrophic trouble into the machine, one trouble at a time, and recording the diagnostic results. The results were reduced to decimal numbers, sorted, and printed in a dictionary-like format together with their associated faulty identification.

The craftsman translates a diagnostic result into a specific trouble identity by matching the trouble number with a number in the manual. The entry gives him instructions on repairing the trouble. Usually, repair consists of replacing a circuit package.

After he has completed the repair, the craftsman checks to see that it actually has cleared the trouble by requesting, via the teletypewriter, a re-run of the diagnosis. If it passes, the repair is affirmed. If it fails, other techniques must be employed. However, the procedure should suffice for the vast majority of faults.

The maintenance plan described in this article has a two-fold aim. First, it should achieve for No. 1 ESS a service life of decades with a total downtime (i.e. periods during which the whole system is inoperative) of less than an hour. Second, it should allow the system to handle thousands of calls between errors. These are rigorous demands. If they are achieved, No. 1 ESS will be among the most reliable digital machines ever built.





*The development of No. 1 ESS cut across many areas of science and engineering. Metallurgists at Bell Laboratories developed a completely new alloy for the ferreed switch and processed old alloys used in the twistor memory to dimensional tolerances that were unheard of a few years ago.*

# Some Magnetic Materials

D. H. Wenny

THE FAMILIAR PASTIME of coining names to characterize an era has produced, for our own times, such sobriquets as The Atomic Age, The Space Age, and The Electronics Age. It could with equal justification be called The Age of Materials. Neither the atom bomb, nor missiles and spacecraft, nor the transistor would have been possible without new materials or a far more complete and precise knowledge of the properties of known ones than had existed previously. New materials and new uses for old ones are the subject of a lively, continuous search, and are among the truly characteristic products of our age.

A strong theoretical base is one significant mark of this trend. Far from the Edisonian method of trying thousands of materials for a job until one is found that works, the contemporary course is first to study the physical phenomena of existing materials. Frequently, this establishes a better understanding of the relationship between the structure and the properties of materials. That understanding may lead, over many paths, to the development of new materials with new properties.

Often, studies may reveal unsuspected properties that make a metal well suited to use in new technologies. Or they may show that it can be worked in a way that alters its properties to adapt them to a desired end. Again, a number of metals with known properties may be combined into an alloy with new properties that uniquely serve a special application. On the one hand, then, research into materials is stimulated by a basic scientific interest. On the other, there is a very practical concern stemming from a pressing need to meet requirements of new technologies.

A unique system, No. 1 ESS demands unique characteristics of the metals that govern many of its functions. Impure magnetic materials in the memory devices, for example, could have a disastrous effect on the system's reliability. Unstable magnetic material in the crosspoints of the ferreed switch could degrade the quality of the voice paths. To a large extent, the accuracy with which No. 1 ESS processes telephone calls is a direct reflection of the quality and performance of the materials in its millions of individual parts. This article will discuss three of those materials. Taken together, they illustrate the re-

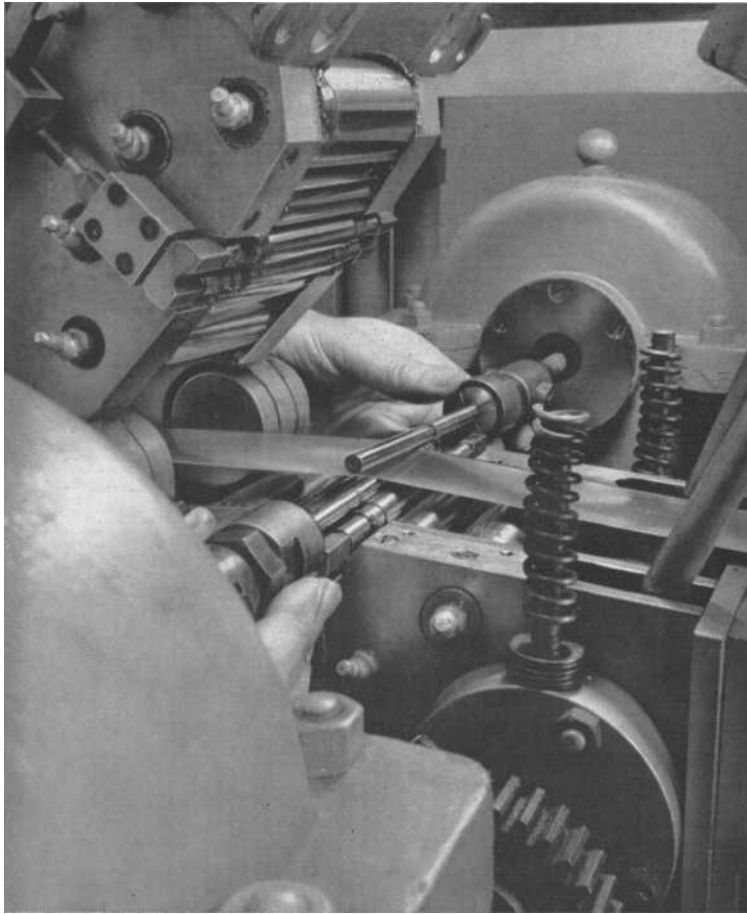

*The laboratory rolling mill used to produce experimental strips of vicalloy foil for the bar magnets of the twistor memory cards.*

search into the properties of metals and the new techniques in metallurgy that Bell Laboratories called upon during the design of the system.

The first material, Molybdenum Permalloy, is an old alloy known for its high permeability and low coercive force. These properties have led to its extensive use in communication system apparatus. But these are normally "soft" magnetic properties. To adapt permalloy for use as the twistor tape of the program store memory (see *Memory Devices* in this issue), they had to be converted, so to speak, to permanent magnet properties. The conversion was affected by new processing techniques first worked out in the laboratory and subsequently translated to large scale production methods.

The second material, Vicalloy, is a contrasting variation on the same theme. It is also an old alloy, but its magnetic properties made it an eminent candidate for the tiny bar magnets of the twistor memory card. However, for that purpose it had to be rolled into extremely thin sheet and put through a continuous strand heat treatment to develop the desired permanent magnetic characteristics. This combination of processing steps, which had never been tried on long lengths

of thin vicalloy sheet, is the primary factor in controlling the magnetic properties. The problem, then, was to develop a reliable rolling and heat treating procedure that could be scaled up to produce thousands of feet of thin permanent magnet sheet with precise control of the basic structure of the alloy and, in turn, its magnetic characteristics.

The third material is Remendur, the latest addition to the family of cobalt-iron-vanadium alloys developed at Bell Laboratories that have had so many uses in communications apparatus. Remendur was developed at Bell Laboratories specifically to fill the need for a temperature stable isotropic magnetic material for the ferreed switch. It has been highly successful in the switch and will be produced in large quantities for this application alone. However, its unique properties may be well suited to many other jobs.

### ***Molybdenum Permalloy***

Molybdenum Permalloy has had many uses in the past thirty years. Its fabrication is a rather lengthy process that includes melting, casting, rolling, drawing, and forming the bulk alloy into the shape required for specific applications. No matter what the final form, however, one step is always taken to remove the mechanical strains resulting from the many preparatory stages: The material is annealed at 1050 degrees Centigrade for an hour or more after it is fabricated. In its fully annealed, strain-free state, Molybdenum Permalloy has a low coercive force of 0.03 oersteds or less and a high initial permeability of at least 20,000.

Permalloy's magnetic characteristics for the 0.3 mil by 4 mil twistor tape (a mil is a thousandth of an inch) are shaped to the needs of a coincident current memory device. This means that the values of the magnetic parameters of the Molybdenum Permalloy are rather sharply changed from those in the familiar form of the alloy. For instance, to permit precise discrimination of the coincident currents, the minimum squareness ratio required for the hysteresis loop is 0.7. Also, to ensure that the tape will deliver a suitable output pulse when it is switched, it must have a fairly high residual induction. The residual induction of twistor tape is greater than 5000 gauss. Finally, to stabilize the residual flux and establish a minimum drive for switching from one remanent state to the other, the coercive force of the twistor is 3.5 oersteds—approximately 100 times its normal value in annealed Molybdenum Permalloy.

A uniform hysteresis loop and a constant value

of coercive force are required over the full length of the twistor tape after it is processed from the rough alloy. This, in fact, is the major metallurgical problem and the greatest deterrent to its successful solution is the variable mechanical strain on the wire during processing operations. For one thing, to reduce the eddy current losses associated with the reversal of magnetization, the alloy is prepared as a flat wire. Flattening reduces some strains and makes it easier to wrap the twistor tape on the copper conductor. In its final form the material is an incredibly thin tape with a cross sectional area less than two millionths of a square inch. A one pound bar of the alloy, a foot long and five eighths of an inch in diameter, is transformed into a ribbon 38 miles long. Obviously, this requires considerable processing.

After the alloy is melted and cast, fabrication begins. The first step is to reduce the alloy to a rod one quarter of an inch in diameter. In laboratory processing, this is done by hot swaging. In larger scale production, by hot rolling. The swaged or rolled rod is coiled and then descaled, annealed, and coated to prepare it for wire drawing. This is done in stages. Tungsten carbide dies are used for the first stages of reduction on the relatively large diameter wire. In the next stage, this wire is processed to a much finer gage. This is done with the diamond dies of multiple die wire-drawing machines. More than 85 dies are required to complete the drawing. Each one brings the wire to a finer, and ever finer, gage.

From time to time the drawing is interrupted and the wire is annealed in a furnace with a protective atmosphere to soften it for further reduction. Since this processing governs the metallic structure of the final product, and because of the inescapable requirement for magnetic and physical uniformity in the wire, every step is rigorously controlled. This process has been highly successful because it draws on fundamental studies in metallurgy conducted at Bell Laboratories in recent years that have established a close correlation between the structure and the magnetic characteristics of the Permalloy ribbon.

### Vicalloy

Vicalloy, the next material, was developed at Bell Laboratories over 25 years ago. It was fabricated as a narrow tape and used as the recording medium for weather and time announcements in Bell System Mirrophones. The name Vicalloy is actually an acronym for a 10 per cent vanadium, 38 per cent iron, and 52 per cent cobalt alloy. It is a malleable alloy that can be rolled to thin gages, and then heat treated to induce a range of perma-

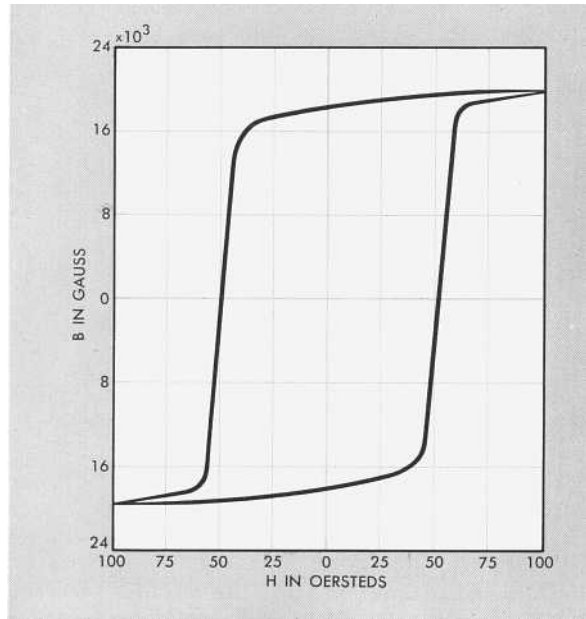

*A typical do hysteresis loop of Remendur composition developed for the series ferreed. The square-ness ratio is 0.9. Illustrating the isotropic qualities of the alloy, this loop was measured at 90 degrees to the rolling direction of the processed strip.*

nent magnet properties. In practice, however, the heat treatment is quite critical and tends to make the alloy hard and brittle.

As a narrow recording tape for Mirrophones, Vicalloy was processed to wire, flattened, and heat treated. Its magnetic properties seemed to be tailor made for the bar magnets of the twistor memory card. But to be compatible with the procedures in fabricating the cards, the Vicalloy had to be rolled and heat treated in long lengths of thin (1 mil) sheet, six inches wide. The danger was that the material would become so hard and brittle during the continuous strand type of heat treatment, that it would not be able to take all the subsequent handling required in fabricating twistor cards.

Heat treatment was also used on the Vicalloy for Mirrophones, but in that application the tape had a small, narrow cross-section of 2 mils by 50 mils, in 500 foot lengths. Rolling and heat treating proved to be a completely adequate, trouble-free way to produce magnetically uniform small sections with a perfect surface. For the twistor memory card, the strip must be 120 times wider and only half as thick.

Little in the tiny magnet on the memory card suggests its beginnings in a massive and rugged ingot. The magnets are a mere 1 mil by 35 mils by

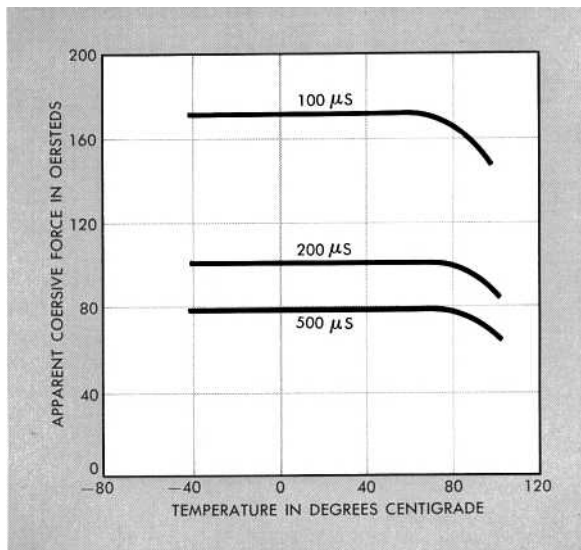

*A graph of coercive force versus temperature in the Remendur developed for the parallel ferreed. Measurements are at three different pulse lengths.*

35 mils, and they must be located precisely on the aluminum card. The first stage in processing is to convert the ingot into a long thin sheet 6 inches wide. This involves a long and intricate hot and cold rolling procedure followed by a continuous strand heat treatment. The heat treated strip is cut to proper lengths for cementing to the aluminum card and a photoresist process is applied to etch away all the Vicalloy except the array of magnets.

Uniform etching is essential and it imposes stringent physical requirements on the strip. It must be absolutely uniform in thickness, perfectly flat, untarnished, and free of any kind of surface blemishes. Magnetically, there is the by-now familiar requirement, it must be magnetically uniform over its entire length and cross section. The process would have been difficult to work out for any material in terms of these requirements, but it was particularly difficult for an alloy so hard mechanically that it required special processing. The procedure we have described was first worked out on a small scale at Bell Laboratories, but it was continued successfully when it was translated to large scale production.

## Remendur

Remendur, the subject of the remainder of this article, is another vanadium, iron, cobalt alloy. In recent years, the magnetic properties of these alloys have been found to be exceptionally well suited to many functions of communication systems equipment. Remendur was developed to

replace the ferrite which proved to be too temperature sensitive for the original ferreed switch. To meet the development schedule of No. 1 ESS, the new alloy was developed in less than 15 months. It started with the pouring of the first experimental 3-pound melt, and ended with the solution of the problems involved in translating laboratory methods to commercial melting and processing procedures for tons of material.

The name, Remendur, reflects the alloy's most significant magnetic characteristic - a remanence greater than 17,000 gauss. Its other properties can be varied for specific functions and include coercive forces ranging from 1 to 60 oersteds, residual inductions up to 20,000 gauss, and hysteresis loops with various ratios of squareness. Thus it bridges the gap between the high coercive force, low permeability characteristics of Vicalloy, and the low coercive force, high permeability properties of such alloys as 2 V-Permendur and Supermendur (RECORD, April, 1960).

Varying the values of the magnetic characteristics in Remendur, is a matter of varying the composition of its component metals. Nominally, the composition is 3.5 per cent vanadium, 48 per cent iron, an equal amount of cobalt, and 0.5 per cent manganese. Vanadium is the key to the coercive force-the more vanadium, the greater the potential coercive force. For any composition of the alloy-it has several-the content of vanadium is calculated as approximately one-tenth the desired coercive force, and iron and cobalt are balanced equally. In most compositions the content of vanadium ranges from 2 per cent to 5 per cent, and the iron and cobalt each make up 50 per cent of the remainder.

Controlled processing also can be employed to vary the magnetic characteristics of Remendur. Adjustments in the coercive force can be made by varying certain steps in the processing and heat treatment. The highly significant characteristic, the square hysteresis loop, is a function of the processing procedure and can be obtained on material in the form of rod, sheet, or round and flat wire. Compositions that contain up to 3.6 per cent vanadium become magnetically isotropic after they are cold rolled to a strip and heated for about two hours at 600 degrees Centigrade. This has important implications which will be discussed shortly.

Remendur begins as electrolytic cobalt, Armco or electrolytic iron, pure vanadium, and 90 per cent or 50 percent ferrovandium. At Bell Laboratories, the alloy has been made by melting and casting these raw materials in air, in a vacuum, or in controlled atmosphere coreless induction furnaces. Consumable electrode are melting fur-

naces also have been used successfully to make large quantities of Remendur. Cast ingots have been hot-worked to one-eighth of an inch in thickness through steps of rolling, forging, extrusion, and swaging. Normally, the alloy is cold worked to thin gages after a drastic quench in ice brine from 925 degrees Centigrade.

The isotropic characteristics of Remendur persist through the processing and permit a freedom in design that is rare in workable permanent magnet alloys. With most alloys, the optimum magnetic quality is obtained only if it is measured in the direction of the rolling operation. Remendur parts can be punched or cut from the strip in any direction and still retain good magnetic quality. This solves what would otherwise be an exceptionally difficult problem in producing a "C"-shaped sleeve magnet which is formed by bending the strip. Cold reduced strip is more amenable to bending across the rolling direction than parallel to it. Moreover, high coercive forces and the rectangularity of the hysteresis loop would suffer if the strip were annealed to facilitate bending.

Though Remendur is mechanically quite hard, it has a persistent malleability and ductility. It has been rolled to sheets or foil as thin as 0.2 mil, and drawn to wires as fine as 1 mil in diameter. Wires have been flattened to ribbons 0.5 mil to 8 mils thick and 5 mils to 65 mils wide. In its first practical application, Remendur supplanted the ferrite posts in the parallel ferreed (the first design). It was worked into wires, ribbons, and rods. The different methods of processing imposed different strains on the alloy, but all its magnetic properties remained intact throughout the processing.

The series ferreed (RECORD, February 1964) which superseded the parallel ferreed, used the "C"-shaped sleeve magnets made from the isotropic strips discussed above. Experimental strips with these qualities were made at Bell Laboratories from a 3.5 pound melt and processed on small, slow-speed laboratory equipment into strips 1 mil to 12 mils thick. The laboratory procedures were then translated to commercial production on a thousand-pound melt. Despite the obvious contrast between small-scale laboratory operations and a production plant, the process worked perfectly to produce sleeve magnets to rigorous design specifications. The drawings on page 259 and 260 give some indication of the magnetic properties that were obtained.

A bipolar ferreed is used as a cutoff device between the switching network and the line scan-

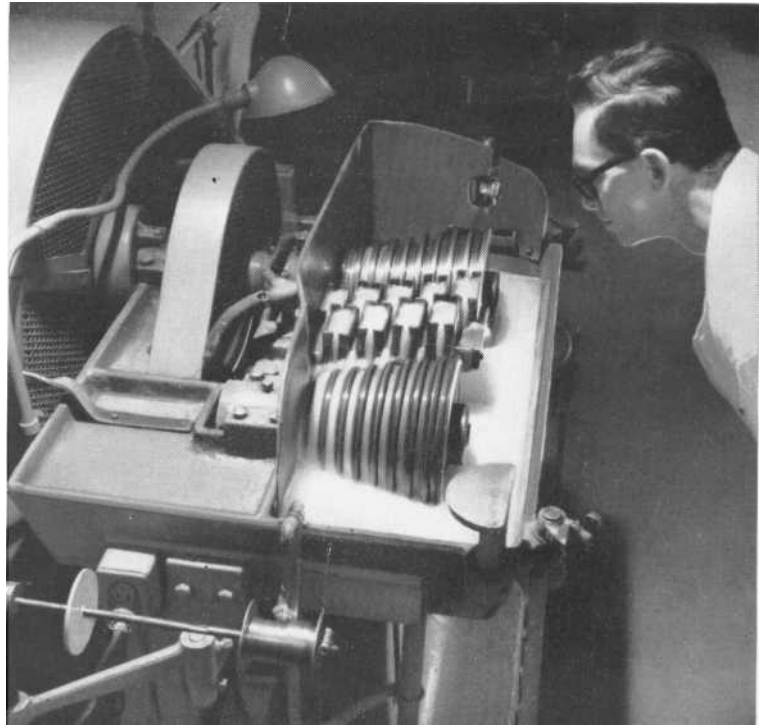

*R. A. Hinrichsen reduces Molybdenum Permalloy wire on a continuous multiple-die wire drawing machine, one step in processing the twistor tape.*

ners in No. 1 ESS. It contains a Remendur rod, actually a bar magnet, with a coercive force of 48 +/- 5 oersteds, a minimum remanent flux of 16,500 gauss, and an energy product of 500 thousand gauss oersteds. Again, small melts at Bell Laboratories served to check the vanadium content and the degree of cold work and the production was then translated to commercial melts that reproduced the specified properties.

During the early stages of manufacture of the series ferreed, the Western Electric Company produced some flat plate magnets to substitute for the "C"-shaped sleeves. Plates can be cut from a strip parallel to the rolling direction and hence do not require isotropic properties. Furthermore, plates do not require the expensive forming procedure of the sleeves. Both plates and sleeves are being used in the Succasunna office in order to compare and evaluate their respective performance.

Some years ago, the Director of the Metallurgical Laboratory at Bell Laboratories told a professional group that metallurgy was moving far to the right of the decimal point. He meant that there would be an increasing need for higher purity materials and for more precise process controls, stretching to measurements in the millionths. No. 1 ESS, as we have seen, is a major part of the technology that has created this need and continues to give it impetus.

*Just twelve basic designs are used in the hundreds of thousands of individual semiconductors in No. 1 ESS. Device designers achieved this compression by exploiting the full capabilities of each design so that it could be used in many circuit functions.*

# Semiconductor Devices

M. L. Embree and J. Sevick

**I**N 1948, BELL LABORATORIES MADE a quiet announcement to the press and started a revolution in the electronics industry. It revealed the invention of the transistor, a tiny device that together with semiconductor diodes held the germ of No. 1 ESS with its hundreds of thousands of semiconductor devices.

The advantages of semiconductor devices were immediately apparent. They operated at extremely low power and did not have either the hot cathodes of vacuum tubes or the mechanical parts of relays. But in 1948, the semiconductor devices were rather primitive. Between them and the semiconductor devices of No. 1 ESS lie almost two decades of intensive research and development pointing toward continually improving electrical performance, increasing reliability, and lowered costs.

By 1956 semiconductor devices were reliable enough to be used in the trial of the Morris electronic central office. And in the eight years between Morris and Succasunna, silicon devices using diffusion technology were perfected and giant steps in reliability were achieved.

By the time development started on No. 1 ESS, many types of transistors and diodes were available to the circuit designer. There was such a large number of types in fact, that indiscrimi-

nately used they could have created difficult problems in development and manufacturing. In No. 1 ESS, therefore, the trend was toward concentration—the goal was as few types of transistors and diodes as possible. Every pertinent factor, from system philosophy to device physics, was weighed in characterizing the types of semiconductor devices No. 1 ESS required. The primary objective was versatile and reliable performance at an overall minimum cost. Most of the transistors and diodes in the system are miniature switching types used primarily in logic circuits. The graph on page 267 shows the different types of devices, their functions, and the number of each type for a typical 10,000 line central office.

A diode coupled AND-NOT gate, generally known as a low-level logic (LLL) circuit, is the basic building block of No. 1 ESS. It is a high performance circuit combining fast switching speeds, large fan-in and fan-out (i.e. the number of signals that can be applied to the input of the circuit and the number it can handle as output, respectively), and excellent margin. With this approach, only three types of transistors and eight types of diodes fill the No. 1 ESS semiconductor requirements. Actually, one of the three transistors, a varistor and a reference diode, are employed in such small numbers that they do not



*Miss Gloria Schirmacher of the Allentown Laboratory rinsing logic transistor slices in preparation for the diffusion process.*

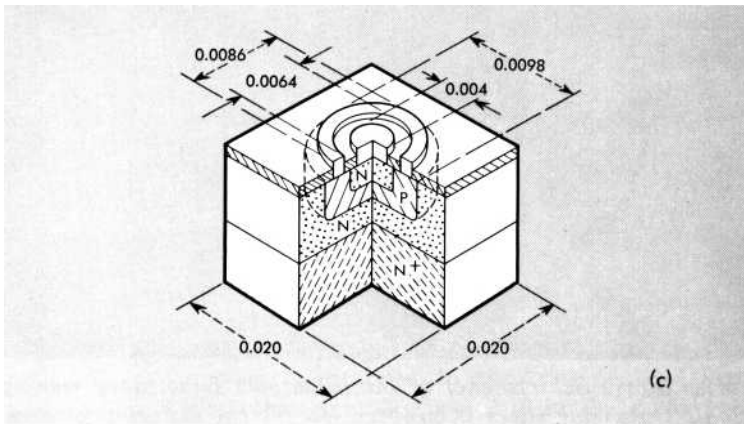
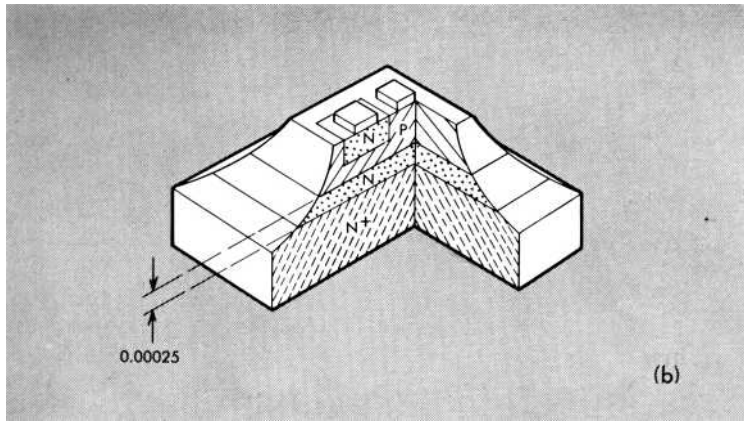
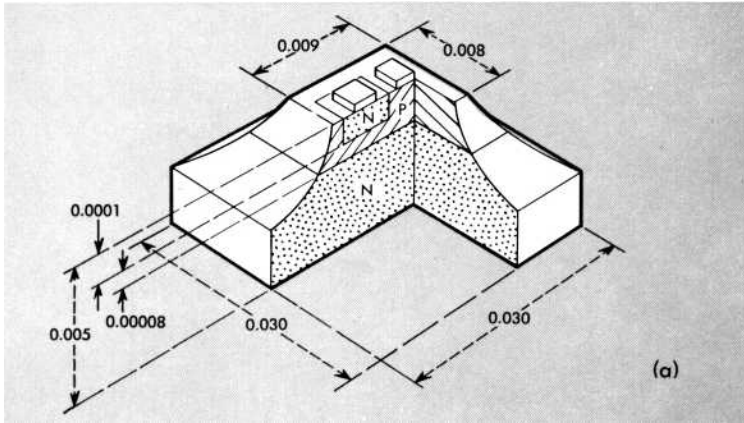

*The evolution of the logic transistor for No. 1 ESS. The first stage (a) is a diffused base silicon mesa structure. The second (b) is an epitaxial structure. The last stage (c) is the planar epitaxial structure. The crystal substrate is designated N+ in (b) and (c).*

appreciably affect the reliability or cost of the system. This article, then, will discuss only two transistors and seven diodes.

### Transistors

The first transistor, designated 29A, is a logic device capable of switching in less than 50 nanoseconds. The second, the 20D, is a 1-ampere memory driver. Prototypes of these devices were first made in 1959, and their developments since then have similar stories of evolving inside structures and outside packaging. This part of the story can be told in terms of the 29A alone.

The history of the logic transistor (see the drawings on this page) begins with a diffused mesa silicon device. To reduce the storage effects of minority carriers in the base and collector regions which hampered switching speed, the wafer was quick-quenched after diffusion. Vacuum-baking was also necessary to remove moisture and this necessitated a tubulated, single-ended case. The great disadvantage of this transistor was that it could not handle the 24 volts required by No. 1 ESS.

Epitaxial transistors, announced by Bell Laboratories in 1960, solved the problem. Growing the desired silicon layer for the device on a highly conducting silicon substrate resulted in lower saturation voltages and higher breakdown voltages. The result was a more efficient switch that met the 24-volt requirement. In this second stage of its evolution, the logic transistor was packaged in a double-ended case allowing it to be placed in slots in a circuit board. This lowered profile contributed to a thinner circuit package.

A planar-epitaxial transistor, the 29A, succeeded the mesa device. These transistors retain all the advantages of mesa-epitaxial transistors and have some improved electrical parameters as well. Junction boundaries for a planar transistor are defined by completely photographic techniques and the junctions are protected by oxide formations. The process leads to devices with lower leakage currents, flatter gain characteristics, and lower base resistances and noise figures. It also contributes toward more economical fabrication and manufacture. For example, because planar wafers are more easily tested than mesa structures, data on uniformity and other important parameters are obtained before wafers are mounted, thus assuring high yields during subsequent steps where the investment is larger. Planar wafers are also less sensitive to ambient conditions than the mesa structure with its exposed junctions.

Changes in the high-current switching tran-



sistor, the 20D, follow much the same pattern of new structures leading to improved electrical performance and reliability. The forerunner of the 20D was a 30-volt 750-milliamper device that, in 1959, was the only transistor available to drive the high currents required of magnetic memories. Shortly after that, the developing requirements of No. 1 ESS created a need for a device with a sustaining voltage of 50 volts and a low saturation voltage above 1 ampere. This occurred at about the same time as the development of the epitaxial transistor, so the new demand and the way to fulfill it coincided.

The epitaxial 20D transistor has a high sustaining voltage, low saturation voltage, high current gain at 1 ampere, and relatively fast switching speeds. Its economy is realized in simpler circuits, larger circuit margins, and an ability to fulfill many amplifying functions.

## Diodes

Diodes comprise the greatest number of semiconductor devices in a No. 1 ESS office. A typical 10,000 line office contains over 200,000 diodes of eight types which are used for logic switching, energy storage, voltage level shifting, memory access isolation, voltage regulation and numerous other relatively minor applications.

Diodes are electronic devices which act as good conductors when voltage of one polarity is applied and perform as good insulators for potentials of the opposite polarity. The critical junction region of the diodes used in No. 1 ESS is formed by high temperature diffusion of boron into one side and phosphorous into the other side of a thin slice of ultra pure single crystal silicon. Ohmic (non-rectifying) metallic contacts are plated on the surfaces and the slice is cut into properly sized and shaped wafers.

Over 80 per cent of the No. 1 ESS diode complement is made up of two types which are used in low level logic circuits, the 447A logic diode and the 449A level shifter diode.

The logic diode (447A) switches milliamper currents in much less than a millionth of a second to perform the required logic functions. The switching speed limitation for these diodes results from charge storage effects which delay the change from on to off by a few nanoseconds. However, this effect does not limit the speed of the low-level logic circuit which depends on other, slower operating, components.

The evolution of the logic diode is similar to that of the logic transistor in that a mesa type is being replaced by a planar design. Both an early design and the present structure utilize

a mesa type "pinhead" diode element (RECORD, September 1963)\*. This diode element (see the drawing on page 266) is similar to a miniature pill box. It is composed entirely of silicon, glass and plated metal contacts and is particularly noted for being the first diode design to achieve a low failure rate at extremely high temperatures. The early design included soft soldered lead connections to the "pinhead" diode element with a plastic molding. This method of connecting leads to the "pinhead" was not completely reliable, and in some cases electrical contact was intermittent.

The present design, a "pinhead" encapsulated in a dark glass cylinder, alleviates the problem. The "pinhead" element is eutectically bonded to the end of a dumet (copper-clad nickel-iron alloy) lead having a pre-sealed glass bead; a U-shaped spring is welded to another dumet lead having a pre-sealed glass bead; and a dark glass cylinder is high temperature sealed to the beads and around the "pinhead" and U-spring assembly. During sealing, a gold-silicon bond is made between the U-spring and the "pinhead" to complete the electrical connections.

The future of the logic diode for No. 1 ESS seems to be the planar structure, the 458C. (See the drawing on page 266.) This recently developed model consists of a planar diode element which is bonded between two molybdenum cylinders during high temperature sealing within a glass cylinder. Dumet leads are welded to the outside ends of each molybdenum cylinder to complete the package. Because of the materials and processes used, this encapsulation is exceptionally well suited to modern reliability and quality control techniques which are carried out under conditions of high thermal and electrical stress. The 458C logic diode has electrical characteristics almost identical to those of the 447A and is easier to handle, harder to damage, and more reliable than any type which has been evaluated.

The level shifter diode (449A) is an essential component of the lowlevel logic circuit. It performs a battery-like function during transistor turn-off. Energy stored in it during forward conduction is used as a source of power to force the transistor to turn off in a fraction of the time it would take otherwise. After both transistor and diode have turned off, the circuit noise margin is greatly enhanced by the roughly two volts forward bias required to turn the diode on.

This diode (see the drawing on page 267) is composed of a stack of three silicon diode wafers simultaneously thermocompression bonded together to a gold plated kovar stud to which a gold plated nickel lead has been welded. The

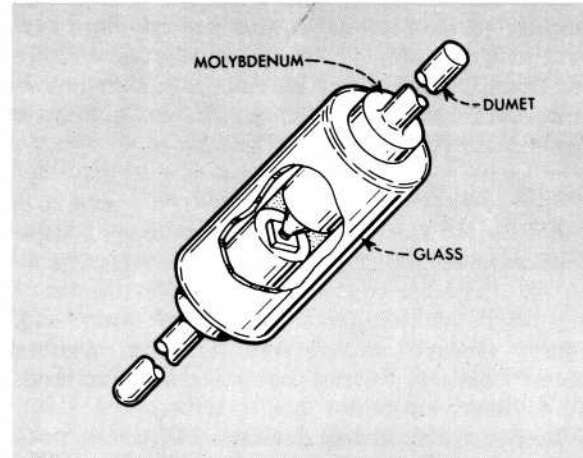
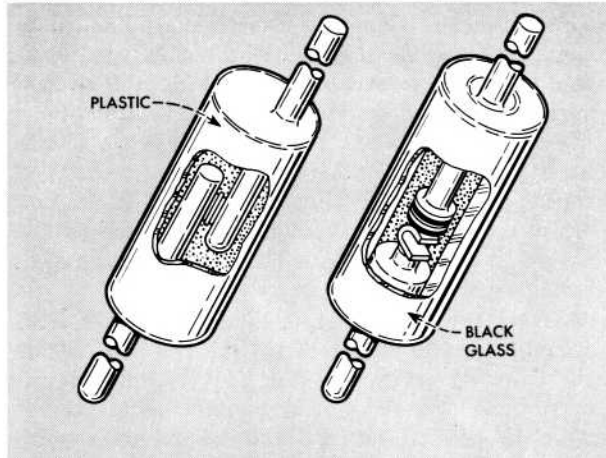
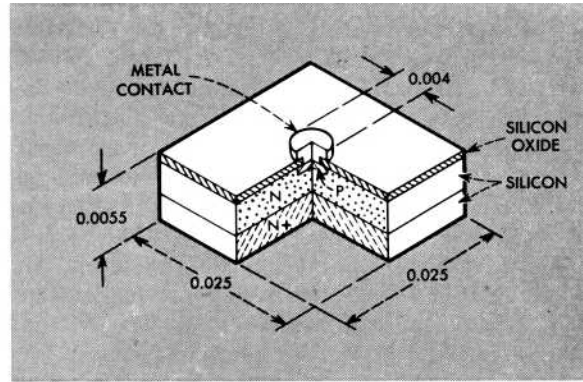
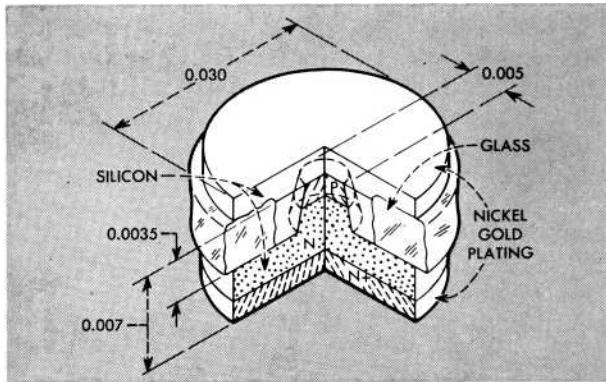

*Evolution of the logic diode from the mesa pinhead, left, the presently used design, to the planar structure, right, which was recently developed and is the future design for the No. 1 ESS logic diodes.*

stud-wafer-lead assembly is welded to a kovar can which includes a high-temperature-glass sealed kovar tubulation. A cold weld pinch off of the tubulation includes the upper end of the gold wire, previously thermocompression bonded to the top of the diode element. This completes the internal electrical connections and makes the final vacuum-tight seal. A gold plated nickel lead with flattened and shaped end is welded to the end of the tubulation to complete the diode assembly. The use of these high melting point materials forms a mechanically rugged and highly reliable package which is used for a large family of diode types.

About two thirds of the remaining diodes in a No. 1 ESS office are the medium speed, medium current, switching type designated 446A. It is used in over 50 different circuit configurations where currents from tens to hundreds of milliamperes must be switched in tens of nanoseconds or longer. Its "on" resistance is less than an ohm and its "off" capacitance is, less than 25 pico-

farads. The structure for the 446A diode is nearly identical to that of the 449A level shifter except that a single diode wafer is used instead of the three deck sandwich.

Voltage regulators, the second category of diodes in No. 1 ESS, are used in relatively small numbers as voltage limiters and voltage control devices. Based in principle on the solid-state avalanche and zener phenomena, they provide a relatively constant voltage over a fairly wide range of values of reverse currents. (Avalanche and zener are breakdown mechanisms that produce an extremely large increase in current from a slight increase in voltage.) There are three types of voltage regulators characterized by different breakdown voltages. The encapsulation for these diodes is the same as for the level shifter diode type 449A and the medium current switching type 446A. (See the drawing page 267.)

Greater current carrying or power handling ability than the 446A diode provides is necessary in some places in No. 1 ESS, such as the twistor

memory access circuits. A high-current diode, the 426AC, can switch currents in the ampere range in less than 100 nanoseconds. The active element in this diode is much like the 446A except that the junction area is about five times larger. The package, like the others we have described, is fabricated of only high temperature materials in order to achieve an extremely high degree of reliability.

In a system as complex as No. 1 ESS, reliability, a key measure of performance in the telephone business, must be specially emphasized. Duplicate, parallel central control units are necessary to permit field modification without service interruption as well as to assure service in the event of equipment failure. Some duplication of peripheral system equipment is also used in No. 1 ESS. This increases the number of components in the office but it leads to an extremely high degree of telephone service reliability. However, even with duplicate critical units, the semiconductor devices must exhibit extremely high reliability.

The field trial of the prototype office at Morris, Illinois demonstrated about one transistor failure every three weeks. At first glance this is reasonable reliability; but for a commercial office it is quite inadequate. The Morris office served only 600 lines and contained about 12,000 germanium transistors, while a typical 10,000-line No. 1 ESS office contains more than 300,000 semiconductors. If No. 1 ESS transistors and diodes had the same failure rate as the Morris transistors they would fail at a rate of about one per day, thus creating a significant possibility that both of the parallel central controls might be unserviceable simultaneously.

Great strides in semiconductor device reliability have been made since Morris. All of the transistors and diodes for No. 1 ESS are made by the newer diffusion technology and use materials which are compatible with high-temperature processing and modern reliability control techniques. Similar devices used in other major electronic systems have shown the reliability required for No. 1 ESS. It is clear that the No. 1 ESS device reliability objective will be met.

At both the Holmdel Laboratory experimental system, and during testing at the Succasunna office, the failure rate of semiconductors has been somewhat higher than the objective rate. However, this is largely the result of system testing and the rate of failures has decreased as the tests come closer to completion.

To sum up, the semiconductor devices of No. 1 ESS have been designed to achieve electrical

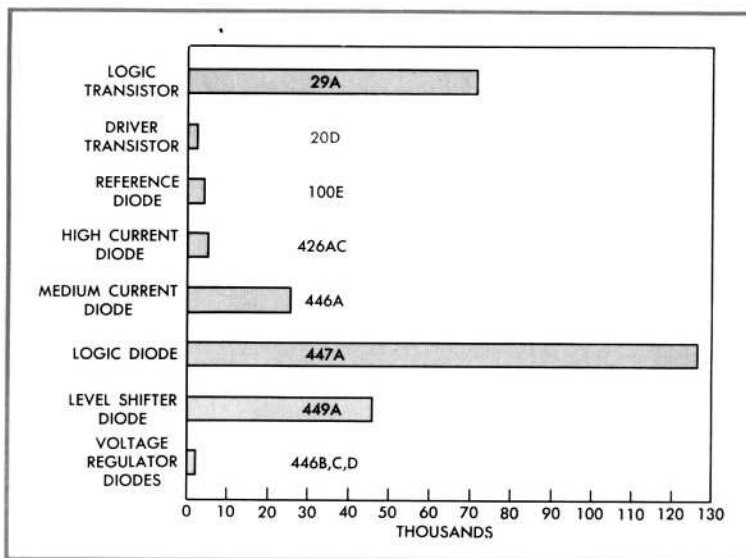

*Semiconductor devices in a typical 10,000 line office of No. 1 ESS.*

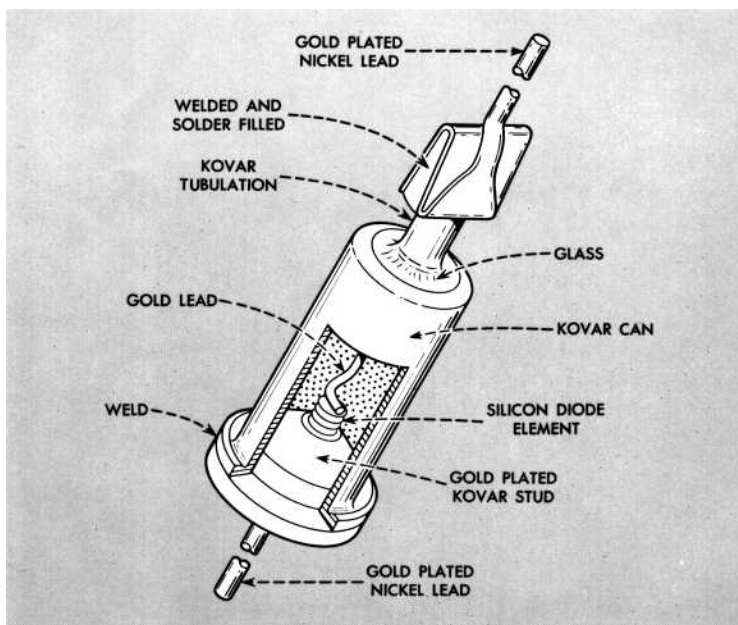

*Encapsulation design adopted for the level shifter diode, the medium-current switching diode and the voltage regulator diodes.*

characteristics suitable for broad uses—mechanical ruggedness to permit automatic circuit assembly; low cost to help achieve economical telephone service; and utmost reliability, reducing office maintenance and achieving the primary goal of accurate, reliable telephone service to Bell System customers.



*H. C. Przybysz, R. K. Voss, and T. E. Jackson (front to back) use the Central Control Manual Tester to test the No. 1 ESS installed for the C. & P. Telephone Co. at Chase, Maryland. The large book in the foreground contains program listings which are used to interpret the displays on the Tester lamp panels.*

*After all the circuits and devices have been fabricated and all the frames and bays have been assembled and wired, there remains a vital task-evaluation testing. At this point the hardware comes to life as a functioning system.*

# Testing the System

R. S. Cooper

**B**EFORE No. 1 ESS can handle even the simplest telephone call, or execute the most routine maintenance procedure, it must be able to respond correctly to any logic problem presented to it. This ability must be tested and proved before the efficiency and accuracy of the program itself-which controls call processing-can be examined.

Any telephone system undergoes some testing at the factory and is run through a gamut of testing after it is installed in a central office building. This testing is performed even on the type of system that has been in production for many years. Its purpose is to ensure that each machine that comes off the assembly line will operate within the values set by the design specifications. A new system, however, may stand or fall on the first machine to be manufactured, because the effectiveness of the whole design is evaluated on the basis of that machine's performance.

Evaluation testing is a two-pronged attack. Its first point is straightforward. Every unit of hardware is tested both for its particular electrical or electronic functions-as a pulse inverter,

or a delay network, etc.-and for its performance as part of an integrated system.

The second point of the attack is much more complex. An effective testing scheme must put a system through all its paces, so to speak. The range of tests must exercise the system in such a way that it demonstrates its response to all situations within the objectives of its design. A precise and meticulous testing scheme can do more than reveal shortcomings, conflicts, and errors in the design. It can suggest, by its results, changes in the design and sometimes in the design objectives.

In a program-controlled system, evaluation testing is equally concerned with hardware and the program. Although the call-processing programs of No. 1 ESS cannot be fully tested until all the system's circuits are operating, special test programs are a powerful tool. Hardware is the first concern and special "X-ray" programs were designed to examine all the hardware units of No. 1 ESS one at a time in sequence. These programs have a very high "resolving power;" that is, an ability to pinpoint the source of an indicated trouble.

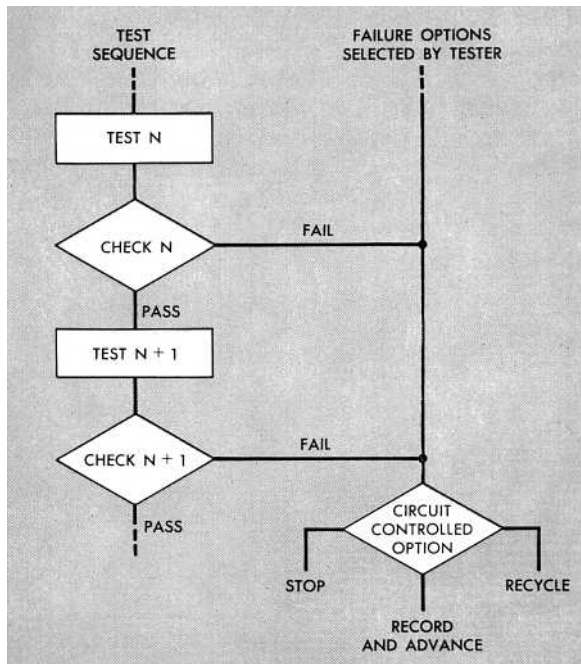

*The sequence of an X-ray program. A test failure causes a transfer to a common failure leg where one of three preselected options may take place. Stopping freezes the machine close to the failure point. "Record and advance" orders a print-out on the teletypewriter of data in the central control registers. "Recycle" continually repeats the test so that test personnel can stop and examine any part of a circuit with an oscilloscope.*

## Testing the Hardware

The system need be only partially installed to begin the sequence of X-ray programs. Only a program store and a central control that can communicate with each other are required. Before X-ray testing begins, however, the two units must have what is known as "basic sanity." That is, the program store must read out binary data without errors in its normal mode, and the central control must do two things. First, it must address the program store and add a binary 1 to a program address. This is a sign that it can execute successive program instructions. Second, it must transfer program control directly from one location to another in the program store, and it must perform a return-address option on a transfer. This is known as a "J" option, and it is the mechanism that shows a tester the point in the program at which a test fails.

Basic sanity is achieved through manual testing with a mobile, plug-in unit called the Central Control Manual Tester (CCMT). In essence, the

CCMT simulates all the units of a working system by sending instructions to central control and governing their execution. Actually, the operator of the CCMT controls the clock circuits of central control and steps them along at manual speeds so that the instructions are carried out one at a time.

These tests look to a two-fold result which, incidentally, illuminates the psychological metaphor, "basic sanity." First, all the hardware necessary for communications between central control and the program store must be operating. The ability to communicate is a fundamental tenet of sanity. In addition to this, there must be no interference from hardware that is not required to operate. Noise, of course, can make chaos of an attempt to communicate.

Using the CCMT, the tester orders central control to send addresses to the program store and to receive words in return. Lamps on the test panel allow him to monitor the contents of a number of flip-flop registers of central control and the states of important circuit points. When the required minimum of basic sanity is achieved, the tester keys a direct transfer to the beginning of the X-ray program and the CCMT releases central control to proceed on its own. However, the CCMT remains attached to central control. During X-ray testing, it is called upon for three important functions.

First, the CCMT provides "flags" that signal central control to stop, or to transfer the program control to a fixed program address. The latter is called an "interrupt." The CCMT contains two program-address match circuits and each one continually compares the program address register with a pre-set number. When a match occurs, the circuits produce a flag. The flag can be used to stop central control in its tracks or to cause an immediate highest priority interrupt. Two memory-address match circuits in the CCMT perform the same operation on memory addresses read out as data.

Second, the CCMT is a data input to central control. Two 24-bit switch groups transmit starting addresses and other data. They also function as control switches to cut in special parts of the X-ray program or to bypass others.

Third, the CCMT continuously monitors central control and displays information on lamp banks. (The unit mounts about 450 lamps.) Lamp indications persist if central control is stopped, and the test operator can test them manually. One lamp bank displays the contents of any desired 24-bit word in the system memory.

The X-ray program consists of a series of

alternating checks and responses. An accurately performed exercise produces a specific result and the check affirms it. If a failure occurs, the machine executes a transfer with a J option and turns control over to a point in the program known as the common failure leg. (See the drawing on page 270.) A program address match circuit set in this leg stops central control. The tester, signaled by the J option lamps on the control console, then gives control of the program to the CCMT.

To clear up the trouble, the program is returned to the test on which the failure occurred. (A lamp group on the CCMT displays the address at which the J option was executed.) The operator now controls the clock circuits and guides central control step-by-step through a repeat of the test. He may use the interrupt to cause the system to cycle repeatedly through the program block in which the failure occurred while the suspected circuits are examined with an oscilloscope. A CCMT match circuit synchronizes the scope and the program.

After the X-ray program has exercised the program store and central control in all their possible circuit combinations, other system units are brought in. The first of these is the central pulse distributor. Again the X-ray program sends orders, and determines the internal condition of the unit from its response. This testing proceeds, in order, through the call stores, the network frames, and all other peripheral units in the system. A specific block in the X-ray program covers each unit.

All the major units of the system, are, of course, duplicated. But the testing to this point covers only one half of the system and takes no account of the other. In fact, the system is considered as two independent halves, and each is tested individually. When all the units have been tested singly, however, the duplicating scheme comes under scrutiny. Duplication schemes vary with different units. Some are simple-the unit may have access to either of two communication bus cables. Other are complex-for example, there are two complete central controls each with a full complement of hardware. In this case, both units are put through the same operation simultaneously and their outputs are matched to assure that they perform identically.

As X-ray testing progresses, a highly sophisticated system begins to emerge from the level of mere basic sanity. It can be called a bootstrap operation. The first tests in the program's repertory clear some units of hardware which can be used in subsequent tests. Early tests are quite

simple, relying only on the hardware necessary to certify the basic sanity of the machine. Later tests are very sophisticated, because they may call on a growing amount of hardware and form complex circuit combinations.

If the motive behind this testing were merely to uncover faulty hardware, wiring errors, and similar faults, the X-ray program would be a needlessly complex procedure. But the power of the X-ray program lies in its critical perception, the ability to constantly compare an image of the system as it should work with the actual performance of the hardware. Common errors would be revealed by something as simple as continuity testing on circuits. But there may be a noise pickup or crosstalk between leads or groups of leads requiring that wiring be rerouted. A circuit may not handle its rated load under certain conditions, or a timing difficulty may lead to marginal operation in some circuits. All these possibilities are foreseen in the X-ray program. The scope of the tests and the range of operating conditions the X-ray program imposes on the system, should reveal the hardware's response to any event it may encounter in actual operating conditions.

### Testing the Program

Evaluation of the stored program itself, commonly called program debugging, follows X-ray testing. Its aim is to create complete harmony among the various sections of the program. An uncoordinated program disrupts the operation of No. 1 ESS, no matter how efficient its hardware. For instance, some program instructions depend on information gathered and stored by immediately preceding ones. However, testing may reveal timing difficulties; the first instruction may not be able to set up information in time for the second. Thus, the program may have to be rewritten so the two instructions do not follow in direct sequence. Other troubles yield only evanescent clues to their source and it may be difficult even to determine if they stem from the hardware or the program. Thus every step in program debugging demands close cooperation between a programmer and a system evaluation engineer who is thoroughly conversant with the hardware design.

Reduced to its simplest terms, program debugging is much like hardware testing-inputs are applied and outputs are checked. At the Succasunna office, input-output, control, and monitoring procedures are shared by the CCMT and the system's teletypewriter, and the control display and test panel of the master control center. At the Holmdel Laboratory, the system includes a pro-

gram test console which offers expanded program and memory matching facilities. About 2500 monitor lamps on the console display information on the state of all major units in the system. To assist in comparing duplicate units, lamps displaying the states of twin points in the two are next to each other on the display panel.

Because time on the machine is a precious commodity, the teletypewriter—the link between testers and the system—is augmented by a card reader. Cards are a very flexible input method; a few can be changed in the deck between runs and there is no need to prepare an entirely new format. Output speed, too, is stretched—a high-speed page printer replaces the teletypewriter output and produces a copy that can be read immediately. This extra equipment increases the input speed of the system to 4800 characters per minute and its output to 80,000 characters per minute.

Match circuits—sets of switches in the console—generate flags which, as in the CCMT, stop the system, interrupt it, or light a lamp. Any of five functions may be selected and used to narrow down the location of the trouble. The tester can choose the following functions singly, or in any combination

First, he may dump the contents of certain memory locations. The data is written out on the teletypewriter or the high-speed printer.

Second, he may *write* into memory locations. Writing may consist of new information to test the system's response, or transferring information already entered to new locations in the call store or central control.

Third, he may *trace* the course of data through the system, by setting central control in an operating mode that causes a dump of memory data at every program transfer.

Fourth, he may jump, or transfer control, from one program location to another.

Fifth, he may *patch* over any program trouble temporarily by giving control to some other routine entered in the call store specifically for this.

An intricate pattern of conditions that is very economical of machine time can be formed with combinations of these five functions. For instance, a programmer running a test may want to patch over a known bug in his program. He may insert a dump before and after the patch. Since he knows that the patch should occur at certain addresses, and that certain data should be stored at those addresses, the dump affirms the effectiveness of the patch. Match circuits and input cards are used in conjunction in these combinatory procedures. A run might be set up as follows.

It may start by writing 30 words in the call

store memory. At the same time utility functions are "planted" at some points, say four points. When the first point is reached, the control may dump two 100-word blocks of memory. The second may start a transfer trace which is continued until another specified point is reached. Along with this, there may be a dump at each transfer. Possibly, the tester may wish to skip one part of the program being run, so there will be a jump at a third point and a patch program is initiated before the jump. Finally, at a fourth point, it may be desirable to send the program in a new direction. This requires specific data from the call store. The tester may write this data into the store, thus forcing the program on its new branch.

The tester may also set flags to deal with troubles as they crop up during the run. For example, a console match circuit can be set to stop the machine if the program writes into the wrong memory block. Another may stop the machine if the last memory address is reached correctly, thus signifying the successful end of the run.

The program used on the No. 1 ESS system at Holmdel has flag instructions planted in the actual call-processing programs. As a call is processed, the flags trigger printouts of its progress giving the input and output parameters of the various program blocks involved in the call. These may include translations, the identity of the network paths involved in the call, the results of hunting for an idle trunk, etc. The amount of information gathered this way is sometimes prodigious. For instance, one complete record of a single call took about 8800 lines of print with an average of 40 characters per line. The amount of information can be controlled, however, and sense switches on the console can be set for partial printouts.

Another actual program dumps a quantity of pertinent information if a reread of a call store fails or if peripheral operations fail to produce correct check responses. Generally, such problems are due to program troubles and not hardware. For example, a program may be written for an office at its ultimate size. This may require many more call stores than the initial installation will incorporate. Thus, a program instruction may instruct central control to pick up information at a call store that does not actually exist. This particular dump, then, will reveal the existence of such program conditions by showing the approximate point in the program at which an action was ordered that could not be executed.

One final phase of testing is executed just before the system is cut into service. This is a thorough operational check verifying that the overall system requirements have been fulfilled.





*The author studies lamp indications on the program test console of the Holmdel Laboratory No. 1 ESS. This console simultaneously monitors 864 points in each central control. The parallel strips display the state of twin points in each control.*

It includes a verification of the system's traffic handling capacity and, against a background of busy hour telephone traffic, checks such things as the accuracy of traffic recording and automatic message accounting, and the effectiveness of the automatic maintenance facilities.

There is a rather interesting testimony to the efficiency of the test methods this article has de-

scribed. System testing using X-ray programs read from the program store began on the Holmdel system in April, 1963 and at Succasunna five months later. Troubles were found and cleared up at a much greater rate at Succasunna than at Holmdel. The primary reason is that the X-ray programs used at Succasunna had themselves already been debugged at Holmdel.

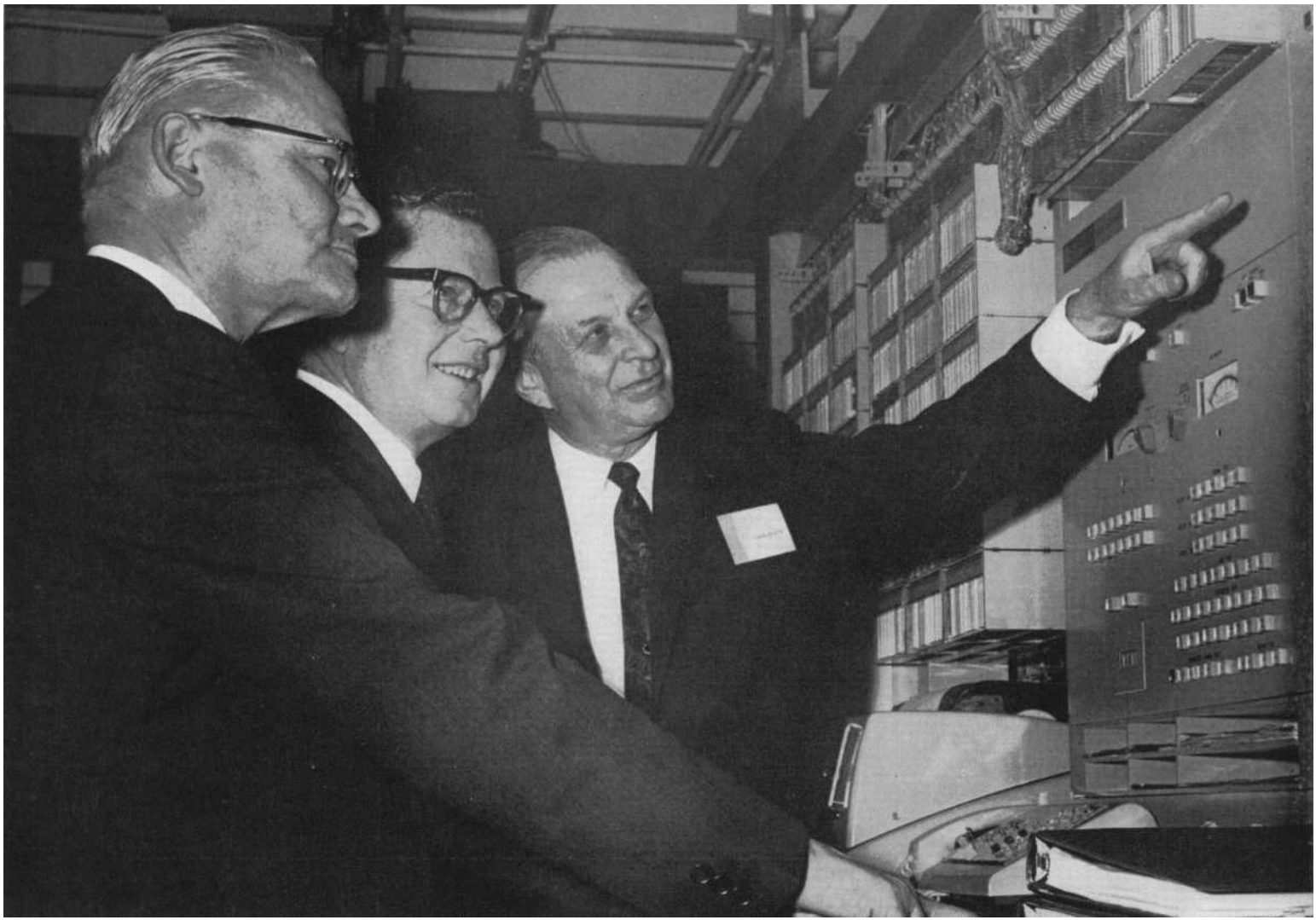

*Frederick R. Koppel, Chairman of the Board of A.T.&T., Richard Hughes, Governor of New Jersey, and E. Homsby Wasson, President of the New Jersey Bell Telephone Co., (left to right) at the master control center of the No. 1 ESS central office at Succasunna.*



*The Bell System's first commercial electronic central office is housed in this building at Succasunna. It began serving 4300 New Jersey Bell Telephone Co. customers on Sunday, May 30, 1965.*

*United States Secretary of Commerce, John T. Connor at the Waldorf Towers, New York City receives an add-on conference call from Governor Hughes at Succasunna. Mayor Louis Nero of Roxbury Township was the third party in the call on No. 1 ESS.*

# Cut-Over At Succasunna

At 12:01 A.M. on Sunday, May 30, 1965 the Bell System's first commercial electronic central office, No. 1 ESS, began to serve 4300 customers in Succasunna, New Jersey.

The first official call through the system had been made two days before during the New Jersey Bell Telephone Company's dedication ceremonies. Governor Richard J. Hughes of New Jersey had initiated the system by adding-on John T. Connor, U.S. Secretary of Commerce to a conversation between him and Mayor Louis Nero of Roxbury Township, New Jersey. Mr. Connor was in New York City and the governor and mayor were at telephones in Succasunna.

Add-on is one of three system "memory services" now being tried by 200 customers served by the Succasunna office. Two more services will be added at a later stage of this trial. (*Features and Services* in this issue describes the five services.)

State, county, and local officials heard A.T.&T. Board Chairman Frederick R. Kappel describe the new installation as one of great significance in the history of communications. He said that No. 1 ESS will "open up an era of communications service that is more personalized, more human, than ever before by reason of its capacity to remember and do various special things that the individual customer wants it to do."

The electronic central office was developed, he said, to serve the future needs of the country for speedier and more abundant communications—in words, in data, in pictures, in symbols. This requires a more efficient and more versatile switch-

ing system than electromechanical devices permit.

"Not until the transistor was invented at Bell Telephone Laboratories in 1948 did electronic switching begin to emerge as a practical prospect," Mr. Kappel said. "Its inventors were investigating certain basic electronic characteristics of matter in the solid state. But whatever purpose beyond the search for knowledge they may have had in mind, there are today some 50,000 transistors in Succasunna's new central office testimony, I think, to the value of so-called 'pure' research to growth and progress".

"Just as the Telstar satellite showed the way to new achievement in intercontinental services," Mr. Kappel said, "so this electronic central office is the forerunner of a new era of convenience for our neighborhoods and our nation. The strength of America's communications system lies in what we call the "switched network"—in the tremendous number of its inputs and outputs, its great speed and versatility, and its ability to connect any user anytime with any other. ESS is going to do this job for us better, faster and—in time—cheaper than ever before.

Succasunna is the first step in the nationwide conversion to electronic switching. Soon to follow are cutovers in Maryland, New York, and California. Mr. Kappel said that a dozen or more electronic offices are now in various stages of installation and that a new office will be installed every working day in the early 1970s. All switching in the Bell System, he said, will be done electronically by the year 2000.

# THE AUTHORS



**W. Keister**

William Keister (*The Evolution of Telephone Switching*) is Director of the Electronic Switching Systems Engineering Center and is responsible for planning the engineering of electronic switching systems. Mr. Keister joined Bell Laboratories in 1930. His early work was on switching and signaling systems. He has organized and taught courses on switching circuit design to Laboratories personnel and is co-author of *The Design of Switching Circuits*. During World War II, Mr. Keister instructed Army and Navy personnel in operating and maintaining radar fire control equipment. He was appointed to his present position in 1958.

Mr. Keister received the BSEE degree from the Alabama Polytechnic Institute in 1930. He is a member of Eta Kappa Nu, Tau Beta Pi, Phi Kappa Phi, and the IEEE.

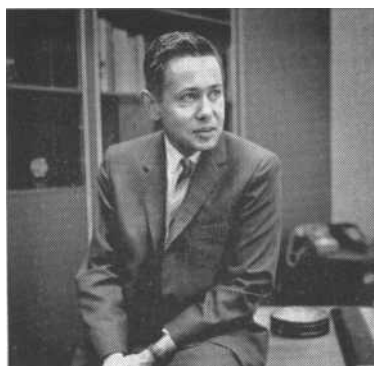

**R. W. Ketchledge**

Raymond W. Ketchledge (*From Morris to Succasunna*) is Director of the Electronic Switching Laboratory. He joined Bell Laboratories in 1942 and for four years was associated with military development of infrared detection and underwater sound systems. During the next six years he participated in the development of a submarine cable system and a broadband coaxial carrier system. In 1953, he was appointed Electron Tube Development Engineer and was responsible for the development of gas tubes and storage tubes. In 1954, he was appointed Switching System Development Engineer responsible for the development of electronic memories and switching networks for electronic switching systems. Mr. Ketchledge was made Assistant Director of Switching Systems Development in 1956 and was appointed to his present position in 1959.

Mr. Ketchledge received his BS and MS degrees from M.I.T. in 1942. He is a member of Sigma Xi and a Fellow of IEEE. He holds 51 patents with 6 pending.

John J. Yostpille (*Features and Services*) is Head of the Local Electronic Switching Planning Department. He is responsible for planning and setting engineering requirements for local central office applications of No. 1 ESS. He first joined Bell Laboratories in 1942 and in 1948 was in the first class of the Communications Development Training Program. He was first concerned with the design of toll switching equipment and after that with electronic switching. Before he was appointed to his present position he supervised a group engaged in systems planning.

Between 1942 and 1948 Mr. Yostpille was on leave of absence from the Laboratories during service in the Navy and studies at M.I.T.

Mr. Yostpille received the BS degree in Electrical Engineering from M.I.T. in 1948 and the



**J. J. Yostpille**

MSEE degree from the Polytechnic Institute of Brooklyn in 1955. He is a member of Sigma Xi and the IEEE.

Eugene H. Siegel, Jr. (Co-author *The Stored Program*) supervises a System Program Group concerned with the design of call processing programs for No. 1 ESS. Mr. Siegel joined Bell Laboratories in 1957 and for three years worked on the design of the barrier grid store circuits and system integration for the Morris trial ECO. Following that he was concerned with call store circuit design for No. 1 ESS and was appointed to his present position in 1963.

Mr. Siegel received the BS in EE degree in 1956 and the MS in EE degree in 1957 from Lehigh University where he held the Gotshall Scholarship in electrical engineering. He is a member of Tau Beta Pi and the IEEE.

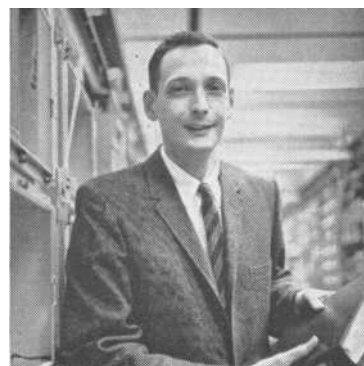

**E. H. Siegel, Jr.**



**S. Silber**

Sigmund Silber (Co-author *The Stored Program*) is a member of the Electronic Switching Programs Department, and has been engaged with the design of the executive control program for No. 1 ESS. Mr. Silber joined Bell Laboratories in 1961. While attending the Communications Development Training Program, he was engaged in various rotational assignments. Since then he has been concerned with the memory and program aspects of No. 1 ESS and certain data processing systems. He established program requirements for more than one data processor using the same memory. Most recently, he has been working with the system program test team for the Succasunna office of No. 1 ESS.

Mr. Silber received the B.A. degree in mathematics from Lehigh University in 1961. He is now studying toward the Ph. D. degree at New York University. Mr. Silber is a member of Phi Beta Kappa.

Anton H. Doblmaier (*The Control Unit*) is a member of the Electronic Switching System Design Department. For the last 10 years he has been concerned with switching development, particularly the logic design of control units for electronic switching.

Mr. Doblmaier joined Bell Laboratories in 1940. Until he transferred to his present assignment, he worked with an apparatus de-



**A. H. Doblmaier**

velopment group designing non-linear networks involving copper oxide and thermistors. He holds one patent on a self-balancing thermistor.

Mr. Doblmaier was born in Munich, Germany. He entered this country in 1931 and received the B.A. degree from Columbia College in 1937 and the M.S. degree from the Columbia University School of Engineering in 1939 where he was a Pulitzer Scholar. He is a member of Phi Beta Kappa, Tau Beta Pi, and Sigma Xi.

L. W. Stammerjohn (Co-author *Memory Devices*) is Head of the Magnetic Memory Department and is responsible for the development of magnetic memory and logic devices. He joined Bell Laboratories in 1940 and was first involved in the development of magnetic amplifiers, ferro-resonant devices, and transformers. Later he worked on the development of automatic tracking circuits for the Command Guidance System. He was appointed to his present position in 1958.

Between 1941 and 1946, Mr. Stammerjohn was on military leave of absence from Bell Laboratories serving on staff and command assignments in Iceland, England, and France. In particular, he served with the signal staff of the Ninth Air Force and was concerned with radar and communications for the control of



**L. W. Stammerjohn**

fighter aircraft operations.

Mr. Stammerjohn received the BSEE degree in 1939 and the MSEE degree in 1940 from the University of Missouri. He is a member of Sigma Xi, Tau Beta Pi, Eta Kappa Nu, and a Senior Member of the IEEE.

R. H. Meinken (Co-author *Memory Devices*) is Head of the Magnetic Materials and Device Department at the Allentown branch of Bell Laboratories. He is responsible for the development of magnetic material and memory devices and other electronic materials.

Mr. Meinken joined Bell Laboratories in 1944 and for his first year was involved in the development of semiconductor devices. During the next four years, his major concern was the development of magnetic materials and

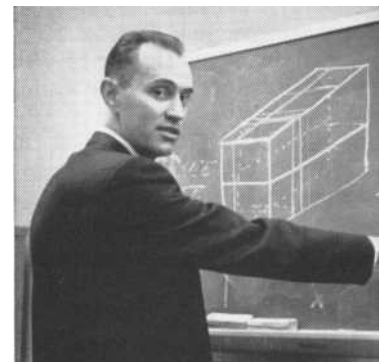

**R. H. Meinken**

# THE AUTHORS (CONTINUED)

memory devices and following that he spent two years on the development of solid state electro-optical devices.

Mr. Meinken received the B.Se. degree in Ceramics from Rutgers University in 1949, the M.Sc. degree in 1951, and the Ph.D. in 1954. He is a member of the American Ceramic Society and Sigma Xi.

A. Feiner (*The Switching Network*) is Head of the Electronic Switching Networks Department and is responsible for the development of switching networks, trunks, and scanners, and for transmission aspects of No. 1 ESS. Since joining Bell Laboratories in



A. Feiner

1953, Mr. Feiner has been associated with various phases of electronic switching techniques.

Born in Vienna, Austria, Mr. Feiner did his undergraduate work at the Vienna Institute of Technology. He received the M.S. degree in Electrical Engineering from Columbia University in 1952. Mr. Feiner is a member of Sigma Xi.

D. H. Wetherell (*Mechanical Design*) Head of the Electronic Switching Equipment Department is responsible for the design and



D. H. Wetherell

development of equipment for No. 1 ESS. Mr. Wetherell joined the Western Electric Company in 1923 and Bell Telephone Laboratories in 1925. He worked on the development of equipment for all types of switching systems until World War II when he was appointed supervisor of a group designing airborne radar systems. After the war he supervised a group working on the development of equipment for toll telephone switching systems and later headed a group developing circuits and equipment for nationwide dialing.

Mr. Wetherell received the B.S.E. degree from Lafayette College in 1923. He is a member of Tau Beta Pi.

J. W. Osmun (Co-author *Power Supply and Ringing and Tone*)

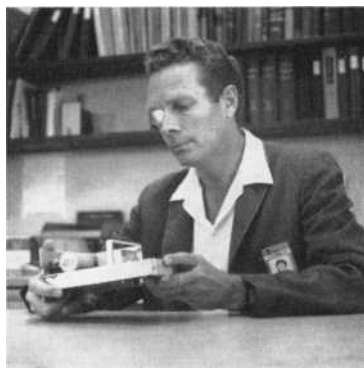

J. W. Osmun

*Plants*) a member of the Power Systems Laboratory, specializes in electronic ringing and tone power plants. He joined Bell Laboratories in 1953 and graduated from the Communications Development Training Program in 1956. His early work at the Laboratories was in ringing power plants and transistorized dc-dc power converters.

From 1943 to 1947 Mr. Osmun served as a parachutist with the U.S. Army, spending one year in the South Pacific theater of operations.

Mr. Osmun received the B.S.E.E. degree from the University of Nevada in 1953. He is a member of Phi Kappa Phi, Sigma Tau, and the IEEE.

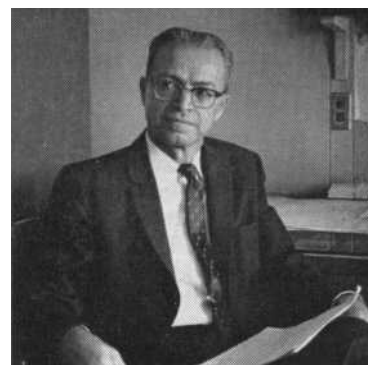

J. R. Montana

J. R. Montana (Co-author *Power Supply and Ringing and Tone Plants*) a member of the Power Systems Laboratory, has been working on precise tone power supplies for No. 1 ESS, step-by-step, and No. 5 crossbar systems. Mr. Montana joined Bell Laboratories in 1944. He was first involved with the mechanical design and the preparation of manufacturing drawings of electromechanical equipment for various systems such as AMA. Later he was concerned with germanium and silicon purifying machines and then with rectifiers and inverters for development leading to the Morris trial. In 1961 he be-

came a member of the Power Development Group and worked extensively on designing equipment for hardened sites and central offices.

Mr. Montana is a graduate of Brooklyn Technical High School and attended the Polytechnic Institute of Brooklyn.

R. L. Campbell (Co-author *A New Approach to System Maintenance*) is a member of the Electronic Switching System Center. He joined Bell Laboratories in 1960 and has worked since that time in the Electronic Switching Maintenance Planning Department at both the Whippany and Holmdel, New Jersey Laborato-



R. L. Campbell

ries. Since joining the Laboratories he has specialized in maintenance planning for No. 1 ESS. His work has involved planning automatic circuits and programs which allow the electronic system to find its own troubles.

Mr. Campbell received the B.S. degree in electrical engineering from the University of Maine in 1960 and the M.E.E. from New York University in 1962. He is a member of Tau Beta Phi and Phi Kappa Phi.

Wendl Thomis (Co-author *A New Approach To System Maintenance*) is a member of the Elec-



W. Thomis

tronic Switching Maintenance Planning Department. He joined Bell Laboratories in 1959 and was first involved with work on the maintenance dictionary for the Morris ECO trial office and with the Morris Switching Network Routine Tests. Since then he has been working on No. 1 ESS and has been responsible for the requirements and general design of the teletypewriter translations and the system maintenance dictionaries.

Mr. Thomis received the B.S. degree in Mechanical Engineering from the Illinois Institute of Technology in 1956 and the M.S.M.E. degree from Purdue university in 1959. He completed the Communications Development Training Program in 1962.

Daniel H. Wenny, Jr. (*Some Magnetic, Materials*) has been su-



D. H. Wenny, Jr.

pervisor of the Metallurgical Development Group of the Metallurgical Research Laboratories for the last 20 years. In the last few years he has been responsible for work on various metal components for the twistor memory arrays and the ferreed crosspoints of No. 1 ESS. Mr. Wenny joined Bell Laboratories in 1930. His first assignment was studying methods of preparing permalloy dust for cores used in loading coils. In his present position he has worked on a wide variety of base and precious metal alloys for magnetic applications, contacts, springs, reed selectors, delay lines, and transmission lines.

Mr. Wenny received the degree of Metallurgical Engineer from Lehigh University in 1930.



M. L. Embree

M. L. Embree (Co-author *Semiconductor Devices*) supervises the Application Engineering and Reliability Group of the Semiconductor Device and Electron Tube Laboratory. He joined Bell Laboratories in 1951 and was first concerned with military systems development. Later, he was transferred to the Allentown Branch Laboratory and assigned to semiconductor device development. In 1955 he was appointed supervisor of a transistor development group working on point contact, alloy, and diffused transistors. He was appointed to his present position at the Laureldale Branch Laboratory in 1958.

Mr. Embree received the B.S. degree in electrical engineering

# THE AUTHORS (CONTINUED)

from the University of Illinois in 1949 and the M.S. degree in 1950. He received an M.S. degree in Physics from Lehigh University in 1957.

J. Sevick (Co-author *Semiconductor Devices*) is supervisor of the Applications Engineering Group of the Semiconductor Device and Electron Tube Laboratory. He is concerned mainly with silicon transistors and integrated circuits. Mr. Sevick joined Bell Laboratories in 1956 and was first assigned to the development of



J. Sevick

high-frequency germanium and silicon transistors. Later he joined a systems group doing exploratory development work in high speed PCM. After that he was transferred to the Lauredale Branch Laboratory and supervised a group in applications engineering. He presently works at the Allentown Branch Laboratory.

During World War II, Mr. Sevick was a pilot and radar officer in the U.S. Air Force.

Mr. Sevick received the B.S. degree in Education from Wayne State University in 1940 and the Ph. D. degree in Physics from Harvard University in 1952. He is a member of a committee establishing an educational television station in the Lehigh Valley.

R. S. Cooper (*Testing the System*) is a member of the Electronic Switching Evaluation Department. He has specialized in systems evaluation, working on the Holmdel experimental No. 1 ESS since 1960.

Mr. Cooper joined Bell Laboratories in 1954 and was enrolled in

the Communications Development Training Program which he completed in 1957. During that time he worked on the design and development of military systems and PCM carrier systems. After these assignments, Mr. Cooper was concerned with the Morris trial ECO. He was involved in liaison with the Illinois Bell Telephone Company in preparation for the trial as well as with system evaluation.

Mr. Cooper received the A.B. degree in Physics from Williams College in 1952 and the MSEE degree from Dartmouth in 1954.



R. S. Cooper



Report from

**BELL  
LABORATORIES**

B. G. Hemmendinger examines one of the digital circuit packages used in the central control unit of the new Electronic Switching System developed at Bell Laboratories. In these circuits, logic functions such as AND, OR, and AND-OR are built up with various combinations of a basic AND-NOT gate. About 27,000 transistors and 90,000 diodes are used in two duplicated central control units for one electronic central office.



## Stored program control- flexibility for telephone switching systems

Modern systems that switch your telephone calls use complex control equipment to operate the switches that make telephone connections. Such "common control" equipment is time-shared by many telephone lines. In electromechanical systems, common control apparatus consists of hardware—an array of hundreds of relays wired together to do the switching jobs of a particular telephone exchange.

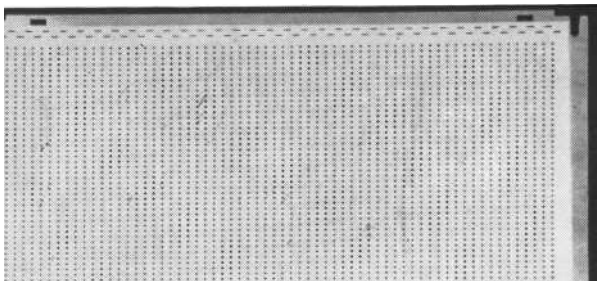

Memory card, 6.5 by 10.5 inches, used for storing the ESS control program. Useful information (64 forty-four-bit words) is carried by the card in the form of magnetized spots ("zero") and unmagnetized spots ("one"). The random-access memory stores the control program and other data on 2048 such cards (131,072 words). The control instructions themselves require a minimum of 100,000 words.

By contrast, common control in the new Electronic Switching System (ESS) developed at Bell Laboratories is exercised by a multitude of general-purpose digital circuits whose actions are directed by "software"-programmed sequences of instructions stored in memory. The operation of ESS, including the specific telephone services provided, can thus be changed merely by changing the magnetization pattern of memory cards like that shown at left, with little or no hardware rearrangement or rewiring.

More specifically, ESS common control consists of an electronic data processor with a large memory. The memory contains instructions for processing all of the different kinds of calls handled by a central office. Guided by this stored program, the data processor receives and interprets dialed digits, sends signals to appropriate switches, and at the same time detects and diagnoses circuit malfunctions.

With this flexible common control, combining hardware and software, ESS can efficiently provide the various telephone services available today as well as any new services needed for the future.



**Bell Telephone Laboratories**

Research and Development Unit of the Bell System