

## ***Modernization of the Suburban ESS:***

# **Billing and Measurements Modernization**

By J. P. LODWIG\* and D. A. WARD\*

(Manuscript received May 28, 1982)

With the introduction of the 2B Extended Feature Generic #3 (2BE3), No. 2B Electronic Switching System has modernized its arrangements for billing and traffic measurements. High-speed, synchronous data links are used to teleprocess billing information to the No. 1A Automatic Message Accounting Recording Center and to forward traffic data to the No. 1A Engineering and Administrative Data Acquisition System Center. This article describes the implementation of these features in the 2BE3 generic and how these new interfaces have resulted in more precise and more reliable data.

### **I. INTRODUCTION**

The billing and traffic measurements capabilities available in the No. 2B Electronic Switching System (ESS)<sup>†</sup> today are the culmination of an evolutionary process spanning more than a decade. During that period, the ESS environment was changing at a very rapid pace, and as a result the billing and traffic measurements processes were continually being upgraded to meet the demands for each generic. Repre-

---

\* Bell Laboratories.

<sup>†</sup> Acronyms and abbreviations are listed at the back of this issue of the *Journal*.

---

©Copyright 1983, American Telephone, & Telegraph Company. Photo reproduction for noncommercial use is permitted without payment of royalty provided that each reproduction is done without alteration and that the *Journal* reference and copyright notice are included on the first page. The title and abstract, but no other portions, of this paper may be copied or distributed royalty free by computer-based and other information-service systems without further permission. Permission to reproduce or republish any other portion of this paper must be obtained from the Editor.

senting the latest capabilities for billing and traffic measurements in the No. 2B ESS are the No. 1A Automatic Message Accounting Recording Center (AMARC) Interface feature and the No. 1A Engineering and Administrative Data Acquisition System (EADAS) feature, respectively. Both the AMARC and EADAS features require near-real-time data collection at the No. 2B ESS. The data are then passed to I/O message buffers for subsequent transmission to an AMARC or EADAS data center. The AMARC formats the billing information for a Revenue Accounting Office (RAO) to use in preparing customer bills, while EADAS provides real-time surveillance and disperses traffic data to various Operation Support Systems (OSSs) for use in maintaining the switching system and planning future growth. Data to the AMARC and EADAS systems are transmitted via synchronous, 2.4-kb data links using the BX.25 protocol. The AMARC feature also uses 4.8-kb data links for those offices presenting too large a load for the 2.4-kb link.

### **1.1 No. 1A AMARC**

Although several hardware and software versions of an AMARC exist today, the No. 2B ESS interfaces only with the No. 1A AMARC equipped with the 1AAM4 generic. The AMARC provides service to various types of switching systems today with several different interfaces giving flexible format, protocol, and data-link speeds between the switching systems offices and AMARC. The AMARC combines the data received from the switching systems into a format acceptable by an RAO. The data are then recorded on magnetic tape, which is sent to the RAO for processing into telephone bills for the customers. Figure 1 represents the interface of a No. 2B ESS with an AMARC.

### **1.2 EADAS**

An EADAS data center (with the 1AED4 generic) connected to the No. 2B ESS (with the 2BE3 generic) receives traffic data and plant data from the No. 2B ESS. The traffic data are load measurements such as peg and usage counts for office totals, and peg, usage, and overflow counts for trunk and service circuit groups. The plant data are measurements that indicate the health of the system. Examples are control unit and peripheral unit diagnostic all-tests-passes and faults. The traffic and plant data sent to EADAS and processed by the EADAS data center are then used by other associated OSSs. The Network Operations Report Generator (NORGEN), part of EADAS, accesses the processed EADAS data directly for its near-real-time reports. Downstream OSSs process EADAS data after they have been sent to them via magnetic tape. Two such downstream OSSs to access the data via the Traffic Data Administration System (TDAS) are

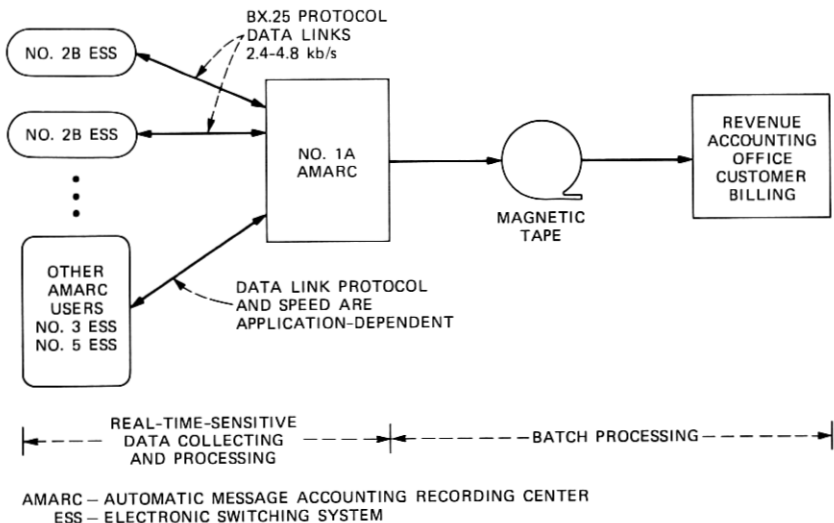

Fig. 1—Interface of a No. 2B ESS with an AMARC.

SPCS COER (Stored Program Control Systems Central Office Equipment Reports) and TSS (Trunk Servicing System). The reports generated by SPCS COER and TSS are needed by network administrators to monitor switching system services, measure utilization, and calculate capacity of the switches, and by trunk administrators to compute trunk group traffic load and current trunk requirements as part of their day-to-day jobs. The capability of providing timely data to SPCS COER and TSS is advantageous (see Fig. 2 for layout). The OSSs can now develop additional needed reports (e.g., summarizing centrex group counts). Also, with the addition of RSS host capability in 2BE3, the traffic data for an RSS is collected by the No. 2B ESS. Extreme Value Engineering (EVE) techniques are used for the engineering of an RSS. The EVE selection is done by EADAS and the engineering calculations are done by SPCS COER.

## II. No. 2B ESS HISTORY AND LIMITS

### 2.1 Billing data collection

Prior to the installation of the 2BE3 generic, the primary method of billing calls was through Local Automatic Message Accounting (LAMA). Other methods used to a lesser degree were Centralized Automatic Message Accounting (CAMA) and in some instances message registers. The choice of billing arrangement was based on applicable tariffs (flat rate or local measured service) and resulting call volumes. Flat rate areas used message registers or CAMA while local measured service areas used LAMA.

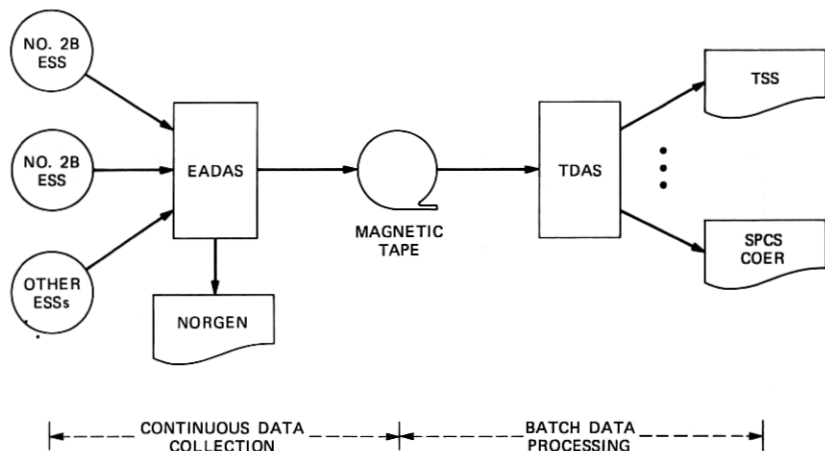

COER - CENTRAL OFFICE EQUIPMENT REPORTS  
 EADAS - ENGINEERING AND ADMINISTRATIVE DATA ACQUISITION SYSTEM  
 NORGEN - NETWORK OPERATIONS REPORT GENERATOR  
 SPCS - STORED PROGRAM CONTROL SYSTEMS  
 TDAS - TRAFFIC DATA ADMINISTRATION SYSTEM  
 TSS - TRUNK SERVICING SYSTEM

Fig. 2—No. 2B ESS and Operation Support Systems.

The LAMA version of No. 2B ESS billing provides the most complete and versatile billing process. However, in some cases daily collection of LAMA tapes could be costly. One possible solution to this first problem was to enhance the software and upgrade the tape recorder to accommodate full measured service billing. However, the collection of the tapes on a daily basis still presents an unattractive cost factor.

## 2.2 Traffic data collection

In a No. 2B ESS office, each teletypewriter (TTY) will serve as a primary output device for one function. A 110-baud data link could be connected from the traffic TTY controller circuit to an EADAS monitored interface. Once it is output to any device, the data no longer exist in the corresponding register, and subsequent output to any other device is not possible. In addition, a large office could not transmit all of the data to EADAS because of the limited data-link speed. Thus, only a subset of the total data was sent (i.e., one or two hours worth each day, assigning different data to the schedules). Another problem was the data skew associated with these output processes. The TTY print rate was 10 characters per second. At this rate it took a minimum of 5 minutes to print a traffic schedule of 600 registers. (Most No. 2B offices have more than 600 registers on a schedule and some require

15 minutes print time for even larger schedules.) The last line of data on a printed schedule is therefore skewed from the first line by the print time. To solve the need for all the data all the time and for accurate data (i.e., prevent data skew) holding registers are added to the 2BE3 generic.

### III. SOLUTION AND NEW PROBLEMS

The inclusion of AMARC and EADAS in the 2BE3 generic provides the increased billing capacity required by the switch and improved traffic information for engineering the switch. This does not preclude the use of billing arrangements available prior to 2BE3 (e.g., LAMA), where increased billing capacity is not required. Also, most of the traffic information capabilities available prior to 2BE3 have been retained. However, as with any new approach, new problems appeared for both AMARC and EADAS. In the early planning phase, one of the more basic problems was establishing interface requirements acceptable to Bell Laboratories systems engineering, AMARC development, EADAS development, and the No. 2B ESS development organization. The selection of a data-link protocol that could be used for both EADAS and AMARC was a highly desirable consideration. Also, during this same time frame, No. 5 ESS committed to AMARC and EADAS for its first application. This further complicated the situation in that now there was another system with a dissimilar architecture and software environment that could affect the development schedule and interface requirements.

### IV. NEW PROTOCOL

Selection of the communications protocol was a major consideration in establishing AMARC and EADAS requirements. A protocol represents a formal agreement on the exchange of information between two or more entities. It provides a multilayered set of rules that govern the interconnecting electrical signals (level one), packetized data (level two), complete message (level 3), and user application data transfer procedures (level 4 and above). Several protocols were considered, e.g., DDCMP, BYSYNC, X.25, etc., but only X.25 had the recommendation of the Comité Consultatif International Téléphonique et Télégraphique (CCITT). Eventually a subset of X.25, now referred to as BX.25, was proposed and accepted as the AMARC feature protocol. Subsequent investigation of this proposal revealed that the proposed BX.25 protocol was also suitable for the EADAS feature. A more detailed presentation of this capability in the No. 2B ESS 2BE3 generic is provided in this issue of the *Journal* in an article entitled "Adding Data Links to an Existing ESS."

## V. INTEGRATION OF AMARC

The AMARC feature encompassed many areas of call processing as well as data integrity and transmittal. Some areas were related to AMARC alone, while others were a consequence of a retrofit constraint that required simultaneous recording by AMARC and LAMA. Rather than attempting to cover the entire scope of AMARC, we will discuss only the basic operational capability and selected concerns.

### 5.1 Basic operation

The AMARC feature collects billing data in real time in the No. 2B ESS and then transmits this data using either a dedicated 2.4- or 4.8-kb/s full-duplex transmission facility or an automatic-dialed backup data-link facility of the same transmission speed in case of primary link failure. The No. 2B ESS/AMARC interface uses a double-entry billing system consisting of an initial/answer entry and a disconnect entry. LAMA recording, however, uses a triple-entry billing system consisting of initial, answer, and disconnect entries. Data for each LAMA entry are collected in real time and loaded into a dedicated LAMA buffer prior to being directed to the tape recorder via I/O control at interrupt level. The use of special AMA registers allows the basic billing structure to remain as it had been for LAMA and still achieve the double-entry billing required by AMARC. Each AMA register is linked with a specific call by direct extension of the Transient Call Record (TCR) memory already designed into the No. 2B ESS architecture. These TCR extensions are then referred to as TCRX registers. The initial billing data are collected and placed into the TCRX registers until answer time and then, upon verification of Minimum Chargeable Duration (MCD), the data are moved into an AMARC data buffer. At disconnect, the data are again collected in the TCRX. When the entry is assembled, it is then loaded into the AMARC data buffer.

### 5.2 Entry association

An obvious requirement for assembling the double entry into one call record by AMARC is the need to associate the initial/answer entry with the corresponding disconnect entry. The method provided by the No. 2B ESS is to map an equipment number (the physical location of a call on the No. 2B ESS or RSS network) into a 15-bit Virtual Equipment Number (VEN) and record the VEN as the low-order 16 bits of a 24-bit Call Assembly Index (CAI) that accompanies each billing entry. The CAI high 8 bits are zeroes except for the case of call-forwarded calls. The special use of the high 8 CAI bits for call-forwarded calls will be described later in this article.

The CAI counterpart in LAMA recording is the Call Identity Index

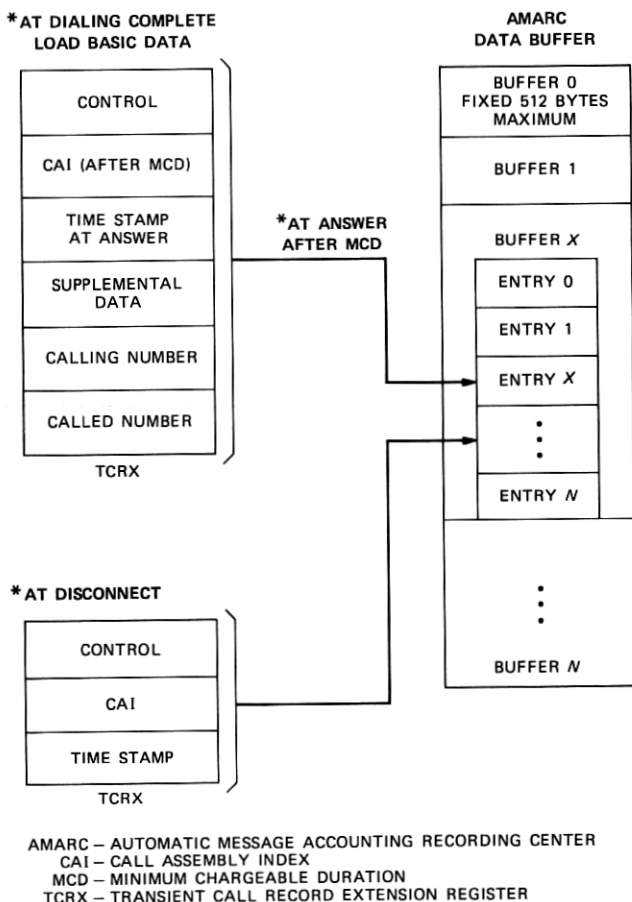

Fig. 3—Basic billing information flow between internal AMARC registers and buffers.

(CII). LAMA recording guaranteed that CII's appearing on the tape would be unique for the duration of a call by maintaining a table of the active CII's derived using a time-consuming hashing scheme based upon the VEN. Since the method of call sequencing associated with the CAI no longer requires the ESS to provide a hashing algorithm, significant real-time savings are achieved for the No. 2B ESS call-processing execution environment. Figure 3 represents the basic billing information flow between internal AMARC registers and buffers.

### 5.3 AMARC data buffer

The No. 2B ESS AMARC data buffer is an engineerable area of read/write memory. The maximum size is designed to provide up to two minutes of billing data storage during a data-link failure. Auto-

matic recovery to the dialed backup data link can be obtained within this two-minute period. The buffer is segmented into message size entities of 512 bytes each. When a buffer segment has insufficient room for the next data entry, or a fixed time limit has expired, the data are either sent immediately or queued for later transmission through the I/O program. The decision depends on available buffer space on the Serial Peripheral Unit Controller for Data Links (SPUC/DLs). Further information on this subject can be found in the article "Adding Data Links to an Existing ESS," also in this issue of the *Journal*.

#### **5.4 Real-time benefit**

The I/O process that moves the data buffer to a SPUC/DL is accomplished at a significant real-time savings compared with the I/O interrupt process for LAMA. Whereas LAMA had a data acceptance limitation (primarily related to hardware design) of three bytes of data within a 20-millisecond interval, the hardware structure of the SPUC/DL allows software definition of the maximum number of data bytes in a message. The I/O design in 2BE3 is flexible but currently allows 256 bytes of data to be sent to the SPUC/DL during one 100-millisecond cycle of the operating systems main loop. Thus, the repetitive I/O overhead associated with small segments of information pertaining to each LAMA recorded call is very significant compared to the AMARC overhead for sending 256 bytes of data for 15 to 20 calls. The overall real-time savings due to the AMARC billing feature, including I/O changes, was 2.8 milliseconds per call (3.6-ms AMARC versus 6.4-ms LAMA). This has the effect of increasing the overall call-billing capacity of the No. 2B ESS when full measured service is offered.

#### **5.5 Auxiliary registers**

For some cases where the data required for a specific call type cannot be contained in a single TCRX register, auxiliary registers are provided to hold the overflow data and are referred to as auxiliary overflow registers. The auxiliary registers are unique to the AMARC feature, while the TCRX registers may be used for other features not related to call processing. The auxiliary registers are associated with the call by placing an index pointer into the TCRX used for the call. Figure 4 shows the connectivity of auxiliary overflow registers plus an extension into auxiliary call-forwarding registers.

#### **5.6 Multiple calls associated with one CAI**

Each leg of a call-forwarded call requires separate billing to each of the parties involved with the call. Since separate billing is required,



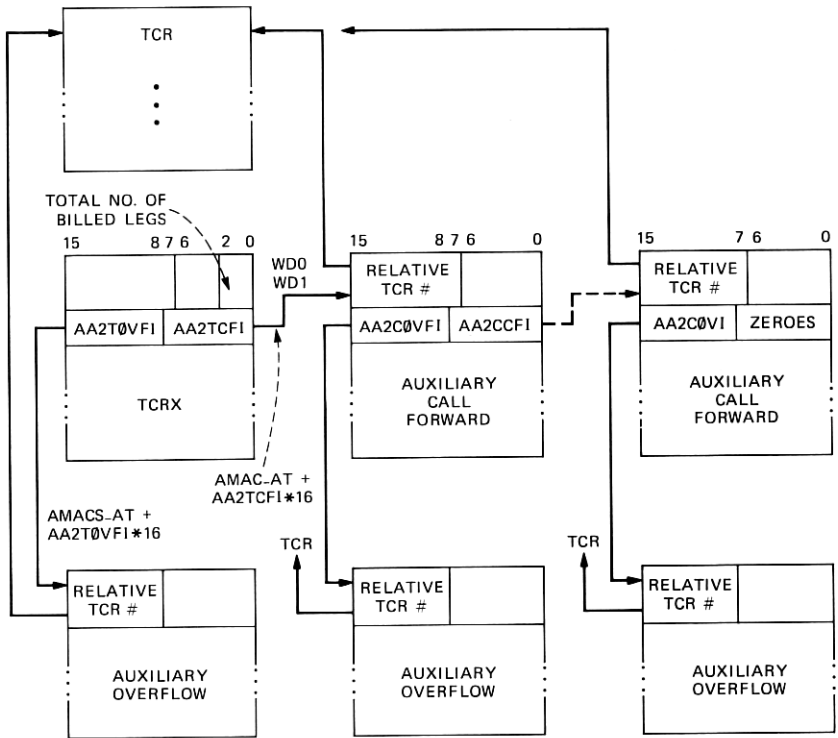

TCR - TRANSIENT CALL RECORD  
 TCRX - TRANSIENT CALL RECORD EXTENSION REGISTER

Fig. 4—AMARC message register interrelation.

the simplest method of administration is to provide a separate initial/answer entry followed by a corresponding disconnect entry for each leg of the call. This requires a different CAI for each billed leg and thus presented a problem in that the only VEN available at disconnect is the originating party VEN. This occurred since the No. 2B ESS call-processing structure prior to the 2BE3 generic did not provide a record of the intervening call legs once the call was made stable. The LAMA billing relied on the CII record table to provide the correct billing entry association. In the 2BE3 generic a record of the number of billed legs of the call is kept in a Stable Information Entry (SIE) during the stable state of the call. The SIE itself is accessed based upon the originating party VEN and codes defining the specific use for that SIE.

Correct billing entry association for AMARC call-forwarded billing records is achieved by prefixing an incremental count to the CAI at answer time for each call-forwarded billing entry except for the first

billed leg of the call. The CAI can then be expressed as the  $CAI = (N-1) * 2^{16} + VEN$ , where VEN represents the 16 low-order bits of the CAI and N equals the billed leg number (1-3) for call-forwarded calls. At disconnect, a billing entry is made for each billed leg of the call by once again prefixing a count to the CAI for each additional billed leg of a call exceeding the first leg. The correct number of disconnect entries is determined by the data available in the SIE.

The initial billing information for call forwarding is collected in the associated TCRX and in supplemental auxiliary registers as required. As in the case of auxiliary overflow registers, call-forward registers are associated with the call by loading an index point to the current register into the register servicing the previous leg of the call. An audit capability is provided by placing the TCR number in each register. Thus, random audits may test a register for activity and, by going to the specific TCR, test for the expected connectivity back to the auxiliary registers originally interrogated. This connectivity is illustrated in Fig. 4.

### **5.7 Retrofit considerations**

Several items of concern exist for the case of an AMARC retrofit into an office previously served by LAMA. One concern relating to the LAMA/AMARC simultaneous recording requirement during retrofits is the administration of call types, e.g., measured service, toll, etc. LAMA entry codes (equivalent to AMARC call types) relating to various calling conditions do not map directly with AMARC call types. This required careful preparation of administrative documentation to allow in some cases a temporary association of call-type categories for LAMA and AMARC. A significant consequence of the call-type association is the ability of the telephone operating companies to validate system operation by comparing the billing records of LAMA and AMARC during the retrofit mode of operation. Another consideration for the retrofit case is the recovery strategy. Since LAMA was the prime billing medium prior to retrofit, all calls billed during the retrofit are obtained from LAMA data tapes; thus all failure modes default to promoting successful LAMA billing.

## **VI. INTEGRATION OF EADAS**

The EADAS feature modified the traffic and plant-collecting and printing routines. With the BX.25 protocol as a common base, developing the interface requirements became a matter of resolving application-level interfaces between No. 2B ESS, No. 5 ESS, and No. 1A EADAS. There are interface differences between the No. 2B ESS to No. 1A EADAS and the No. 5 ESS to No. 1A EADAS due to the

different architecture structures of No. 2B ESS/generic 2BE3 and No. 5 ESS. Having the No. 2B ESS conform to the identical interface between No. 5 ESS and No. 1A EADAS would cause a real-time penalty to No. 2B ESS. The resulting operational interface between the No. 2B ESS and No. 1A EADAS is described next.

### **6.1 Basic operation**

The high-speed EADAS interface feature provides for the collection and transmittal of both traffic and plant measurement data to No. 1A EADAS. With this implementation the traffic and plant measurement data are collected on two schedules—a 30-minute schedule and a 24-hour schedule. The schedules start collecting 30 seconds before the clock 00 minute and 30 minutes and finish by one minute after 00 or 30. The data are collected and stored in holding registers within 90 seconds, resulting in a maximum of 90 seconds of data skew. The data for most offices will be collected within 30 seconds. The resulting data skew of 30 to 90 seconds is significantly more accurate than the previous skew of 5 to 15 minutes. Schedules are not transmitted until a poll is received from No. 1A EADAS requesting a schedule. The No. 2B ESS and No. 5 ESS communicate with the 1AED4 generic of No. 1A EADAS using the BX.25 protocol.

The interface between the No. 2B ESS and the No. 1A EADAS is a poll-and-answer mechanism. The No. 1A EADAS polls for four types of data:

1. Time of day
2. 30-minute data
3. 24-hour data
4. Record base (working member) data.

The No. 2B ESS answers with the:

1. Time of day
2. Data from the H (specified busy hour), C (specified nonbusy hour), W (specified weekly), and PLT (specified plant) schedules
3. D (daily or division of revenue) schedule
4. Working member count of trunk and service circuits for each poll.

The No. 1A EADAS also sends a message when it is planning to discontinue operation temporarily for such things as maintenance. The No. 2B ESS accepts the message and prints out a message to the TTY to inform the craft. The No. 2B ESS can send error response messages to No. 1A EADAS: (1) when the data for a message have been overwritten because current polling from the No. 1A EADAS is still continuing when the next collection is started, or (2) if a poll comes in when the 2B is collecting data for a message.

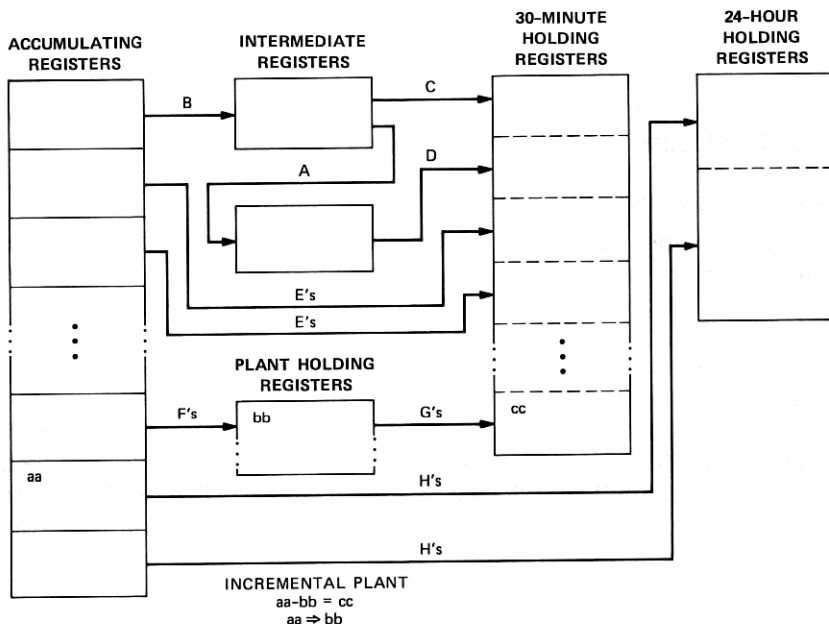

A AND B — DONE EVERY 15 MINUTES  
 C, D, E's, F's AND G's — DONE EVERY 30 MINUTES  
 H's — DONE EVERY 24 HOURS

Fig. 5—Data collection.

## 6.2 Data collection

Data collection is started every quarter hour to collect the intermediate counts and every half hour to collect the 30-minute counts. Also, the 24-hour counts are collected at midnight before the 30-minute counts. In Fig. 5 the lines A through H match the description of each type of count. The quarter-hour counts, load service measurements, are moved to the intermediate registers (A and B). The intermediate registers contain two sets of these registers, the previous quarter hour's and the current quarter hour's. The two sets of counts are kept until the half hour when both sets are moved to the 30-minute holding registers (C and D). Also, every half hour the counts such as office totals, service circuit, trunk circuit, multiline hunt, and simulated groups, junctor usage, centrex, and network usage are moved to the 30-minute holding registers (Es). Then the half-hour increment of the plant counts are moved to the 30-minute holding registers (Fs and Gs). This is done by subtracting from the current plant accumulating counts the intermediate plant holding registers, storing the difference in the 30-minute holding registers, and moving the accumulating plant

counts to the intermediate plant holding registers. The 24-hour counts, division of revenue, are moved to the 24-hour holding registers (Hs).

### **6.3 Override No. 1A EADAS**

If necessary, the 2BE3 generic can revert to the standard H, C, W, and D schedules through human intervention. When an office has EADAS active, the 30-minute data are from all the data that could have been on the H, C, and W schedules and the 24-hour data are from the D schedule. An office could revert to the standard schedule output if desired or if the No. 1A EADAS center would go off-line for an extended period of time. The No. 2B ESS office would then provide the data on hard copy and paper tape punch. In the No. 2B ESS, the standard schedules are printed automatically under the control of the Traffic Work Table (TWT) from the holding registers. This arrangement (non-EADAS) does not support RSS EVE engineering needs for SPCS COER. This mechanism is overridden when EADAS is active and it can be reenabled with a single TTY input message to inhibit EADAS.

### **6.4 Interface differences**

Because of the differences in No. 2B and No. 5 ESS architecture, the interface with No. 1A EADAS does differ on three points:

1. The No. 2B ESS keeps time differently than the No. 5 ESS.
2. The No. 2B ESS does not indicate overflow of registers through the special register values as does No. 5 ESS. The values 65,526 through 65,535 are used as special register values, i.e., for overflow, bad data, and unequipped register.
3. The 2B transmits two-byte data low byte first instead of the reverse.

Therefore, the No. 1A EADAS does handle these differences. For the No. 2B ESS to have followed the same interface as between No. 5 ESS and No. 1A EADAS on these three points would have cost the No. 2B ESS a real-time penalty.

## **VII. SUMMARY**

The addition of the AMARC and EADAS features to the 2BE3 generic enhanced the No. 2B ESS capability. AMARC achieves the billing systems goals of reduced operating expense while providing full measured service billing capability for the No. 2B ESS. Also, owing to a redistribution of tasks and restructuring of the programs, AMARC allows higher call capacity in the No. 2B ESS compared with LAMA billing.

All traffic and plant data are sent to EADAS, which allows for the efficient integration of the local switching systems into Total Network

Operation Plan (TNOP). Also, owing to the addition of holding registers there is virtually no data skew. The EADAS feature is using a communication interface that could support network management messages and controls in a future generic.

### VIII. ACKNOWLEDGMENTS

The authors extend their appreciation to all of the 2BE3 development team for their cooperation in providing the AMARC and EADAS capabilities for the No. 2B ESS. In particular, we wish to thank Iris Dowden and Eric Kampmeier for their contributions towards AMARC and Wendell Savino for his participation with EADAS.

### AUTHORS

**Deborah A. Ward**, A.A.S. (Computer Technology), Purdue University Calumet Campus; Bell Laboratories, 1973—. After joining Bell Labs in 1973, Mrs. Ward worked on No. 3 ESS and No. 2B ESS projects. During this time, she was involved in the translations design and the program design, coding and testing of the translations access routines for No. 3 ESS. She also was involved in maintaining the administrative traffic program for No. 3 ESS. Her work on No. 2B ESS has also been in the administrative traffic area. Mrs. Ward has been a member of the No. 5 ESS Data Base Design Department at Bell Laboratories in Naperville, Illinois, and since early 1982 has been working on the No. 5 ESS project.

**John Ludwig**, B.S.E.E., 1971, Illinois Institute of Technology; Bell Laboratories, 1967—. Mr. Ludwig's initial work at Bell Laboratories involved circuit design with the No. 101 ESS, and later the 3A Common Controller, which has been used as a central processor for several electronic switching systems, e.g., No. 2B ESS, No. 3 ESS, etc. In 1976, he made the transition from circuit design to software design and became involved with automatic message accounting billing. It was during the period from 1976 through 1980 that he became involved with the Automatic Message Accounting Recording Center (AMARC) billing feature for the No. 2B ESS. More recently, Mr. Ludwig has been working with common channel interoffice signaling and domestic local planning for the No. 5 ESS.