

THE BELL SYSTEM TECHNICAL JOURNAL

DEVOTED TO THE SCIENTIFIC AND ENGINEERING
ASPECTS OF ELECTRICAL COMMUNICATION

Volume 62

December 1983

Number 10, Part 1

Time-Compression Multiplexing (TCM) of Three Broadcast-Quality TV Signals on a Satellite Transponder

By K. Y. ENG,* B. G. HASKELL,* and R. L. SCHMIDT*

(Manuscript received June 15, 1983)

We describe how Time-Compression Multiplexing (TCM) might enable the transmission of three National Television System Committee (NTSC) color TV signals through a satellite transponder of 36-MHz bandwidth. The input TV signals are processed such that three fields from each TV source are compressed into an ordinary field period. This is accomplished by sending one field as is but time compressed; the other two fields are sent as differential signals, also time compressed such that all three fit into a single field period. The resultant compressed waveforms are then time multiplexed between the three sources and have a combined baseband bandwidth of 7.52 MHz for an optimal case, or 8.4 MHz for a practical version. In either case, both the transmitter-multiplexer and the receiver-demultiplexer require only three field memories for (digital) signal processing. Performance is expected to be of network broadcast quality (i.e., weighted signal-to-noise ratio, $s/n \geq 56$ dB) for the optimal case of 7.52-MHz baseband if 12-meter receive earth stations

*Bell Laboratories.

©Copyright 1983, American Telephone & Telegraph Company. Photo reproduction for noncommercial use is permitted without payment of royalty provided that each reproduction is done without alteration and that the Journal reference and copyright notice are included on the first page. The title and abstract, but no other portions, of this paper may be copied or distributed royalty free by computer-based and other information-service systems without further permission. Permission to reproduce or republish any other portion of this paper must be obtained from the Editor.

are employed in a system such as COMSTAR. The practical version, on the other hand, would yield an $s/n \approx 54$ dB.

I. INTRODUCTION

The problem of transmitting two or more high-quality TV signals through a satellite transponder of 36 MHz continues to be a challenge in optimizing the use of available transponders in current as well as near-future satellites. It was recently proposed¹ that by combining the concepts of Time-Compression Multiplexing (TCM)^{2,3} and differential signals,⁴ two or more National Television System Committee (NTSC) TV signals can be time multiplexed with bandwidth reduction for transmission with a single FM carrier in a satellite channel. This avoids crosstalk between the pictures. In fact, straightforward TCM alone would permit the transmission of two TVs in a transponder with performance close to broadcast quality [i.e., peak-to-peak video signal to weighted root-mean-square (rms) noise ratio, $s/n \geq 56$ dB] if 12-meter receive earth stations were used in a satellite system such as COMSTAR. The additional application of time-companded (time-compressed or expanded) differential signals reduces the TCM signal bandwidth and thus can enhance the transmitted picture quality or enable the inclusion of a third TV signal. However, the implementation of such a system as described in Ref. 1 involves converting the input TV scan pattern from interlacing to sequential. This would mean considerable memory needed, particularly in the case of three TVs per transponder. Here, we describe an implementation that offers significant saving in memory, considerable relaxation in timing requirements, and easy adaptation to existing hardware. The technique essentially uses three field memories time shared between the three simultaneous, but *synchronized*, input TV signals to produce differential signals in a proper format for TCM. The receiver, on the other hand, also requires three field memories to reconstruct all three TV signals. Practically all the signal processing could be implemented digitally.

We will describe the details of the present system in the next section. The performance of this could be of broadcast quality if 12-meter receive earth stations were used. Finally, we will discuss the inclusion of audio, up-link synchronization for transmissions from separate earth stations and possible extensions to non-NTSC TV signals.

II. SYSTEM DESCRIPTION

Figure 1 shows the block diagram of a transmitting earth station with three *synchronized* NTSC TV signals that are combined for transmission by a single FM carrier. The use of frame synchronizers

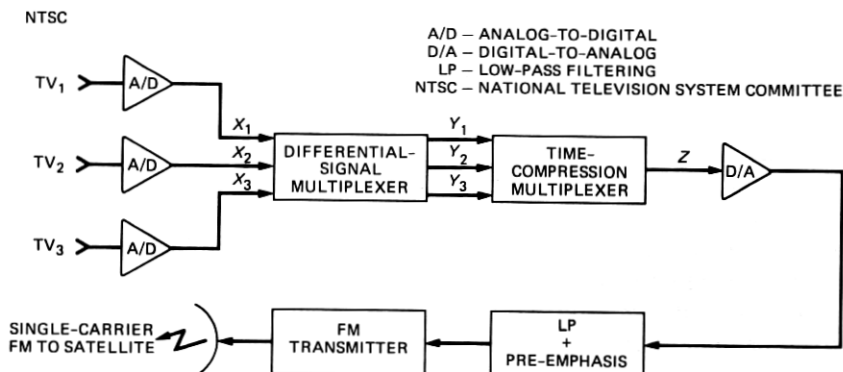

Fig. 1—Transmit earth station for the three TVs per transponder.

is therefore implicit if the three TV sources are not synchronized (the case of noncolocated TV sources is discussed later in Section IV). The TV inputs are first digitized individually. The digitized TVs, denoted by X_i ($i = 1$ to 3), are processed by the differential-signal multiplexer, where various differential signals are formed and multiplexed in its three digital outputs Y_i ($i = 1$ to 3). These signals (Y_i) are then passed through the time-compression multiplexer, which combines them into a single digital stream, Z . The conventional operations of digital-to-analog conversion, low-pass filtering, and preemphasis are performed before transmission to the satellite with a single FM carrier. We will describe the differential-signal multiplexer and the time-compression multiplexer in detail in the following sections.

2.1 The differential-signal multiplexer

We could use three types of differential signals: line differentials, field differentials, and frame differentials.^{4,5} Each type in turn can be defined in many ways. They have all been described in the cited references, and only a brief summary is provided here for the purpose of subsequent discussions.

Line differentials can be defined as a difference signal between two successive scan lines in the same field. In their digital implementation, this would mean a difference between more or less vertically adjacent picture elements (pels) from two successive lines in the *same* field, and they are chosen such that their amplitude is much smaller, on the average, than the original signal. But most importantly, the difference signal can be band limited to ≈ 3 MHz without degrading picture quality. Field differentials are defined essentially in the same way as line differentials except that the difference signal is derived from pels in adjacent scan lines in two successive fields. The bandwidth of field differentials can be further limited to ≈ 2 MHz without affecting

picture quality. These results were verified and used in a previous experiment.⁵

Frame differentials are merely an extension of the above by using pels from two temporally adjacent (or spatially coincident) lines from two successive frames. They have not been studied so far, either by computer simulation or hardware implementation. Thus, we can only speculate as to their performance. Their amplitudes may be larger than field difference amplitudes for pictures containing movement, whereas for pictures containing no movement they should be smaller. The bandwidth required for frame differentials should be comparable to or smaller than that needed for field differentials. In this regard, much depends on the relative visibility in the picture of distortions occurring at the field rate and the frame rate in detailed or moving areas of the picture. In the following discussion, we will use the field and frame differentials; the use of line differentials will only be a possible, though unlikely, extension of the system.

Our attention returns now to the differential-signal multiplexer, an illustrative implementation of which is shown in Fig. 2. The following explanation will show that the field- and frame-differential generators in this figure could just as well be replaced by two field-differential generators with some connections slightly modified. The key characteristic to note in Fig. 2 is that only three field memories are needed to produce all the differential signals required for the three input TVs.

The three input switches, S_1 , S_2 and S_3 , move in synchronism from the top position to the middle, to the bottom, and back to the top, etc.

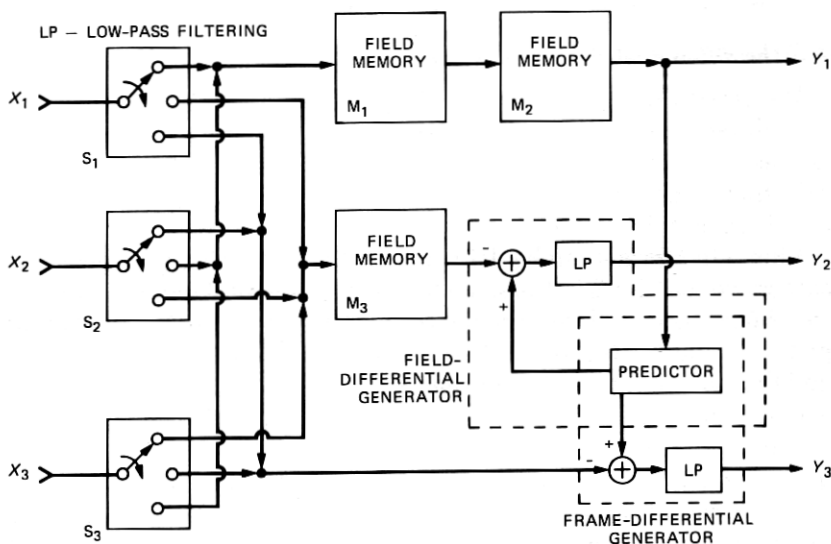

Fig. 2—The differential-signal multiplexer.

They all change position simultaneously sometime during the vertical blanking interval in such a way that complete fields of the input video are routed to either the top, middle, or bottom path.

To demonstrate how this works, we consider Fig. 3, where all the waveforms are digital. In the top of the figure, the three synchronized input TV waveforms are shown with T being a field period ($\approx 1/60$ second) and F_{ij} being the j th field from the i th TV source ($i = 1$ to 3). When F_{11} arrives, we assume that S_1 , S_2 , and S_3 are in the top position, as shown in Fig. 2. F_{11} is written onto field memory M_1 from time zero to T . The switches then change to the middle positions, and F_{12} is written onto M_3 while F_{11} , in M_1 , is being transferred to M_2 . At the same time, F_{21} is also written onto M_1 . Consequently, at the end of $2T$, F_{21} is stored in M_1 , F_{11} in M_2 , and F_{12} in M_3 before the switches change position again. Now with the switches in the bottom position, F_{13} is routed to the bottom path. It is then used to form a frame differential with F_{11} , from M_2 , denoted by $F_{11} - F_{13}$, which is the

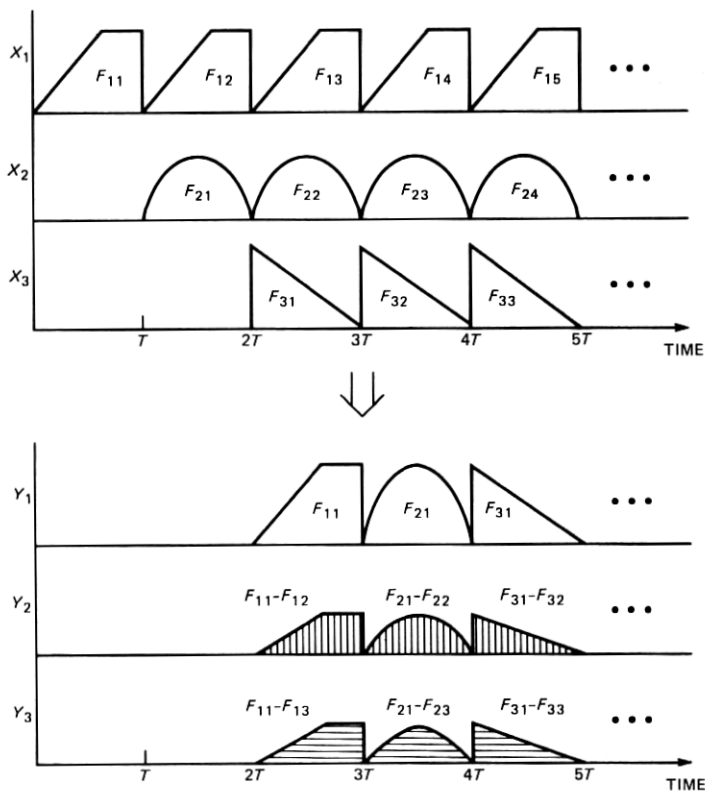

Fig. 3—Input/output waveforms for the differential-signal multiplexer.

output Y_3 . The original unchanged signal F_{11} is also read out from M_2 via Y_1 . The remaining output Y_2 , is a field differential derived from F_{11} (from M_2) and F_{12} (from M_3) and is denoted by $F_{11} - F_{12}$. While all these are taking place, F_{21} , from M_1 , is transferred to M_2 with F_{31} being written onto M_1 , and F_{22} is written onto M_2 . These operations are repeated for all subsequent fields. The output waveforms are illustrated in the bottom of Fig. 3, where a processing delay of $2T$ is incurred. Such a delay enables the conversion from line-multiplexed serial inputs into time-multiplexed parallel outputs. Furthermore, there is flexibility in choosing which of the fields is to be read out as is and which type of differential signal is to be used. For instance, in the above example we could just as well send F_{12} as is, send $F_{11} - F_{12}$ as a field-differential signal, and send $F_{13} - F_{12}$ as another field-differential signal. In any event, in every T -second output interval, there are always one original field plus two differential fields in the three outputs. The bandwidth of the original field is 4.2 MHz, and that of the differential signals is assumed to be 2 MHz.

2.2 The time-compression multiplexer

The purpose of the time-compression multiplexer is to combine the three signals (Y_1 , Y_2 , and Y_3) from the differential-signal multiplexer into a single signal, Z . In other words, we would like to time compress the three inputs over every T -second interval into a single output with the same duration. This can be achieved by writing the digital words into a memory (say, a RAM) at one speed and reading them out at a faster speed (see Fig. 4). The ratio of the read clock to the write clock is the time-compression factor (>1 for time compression). Since the time compression is to be done over a T -second interval, we could

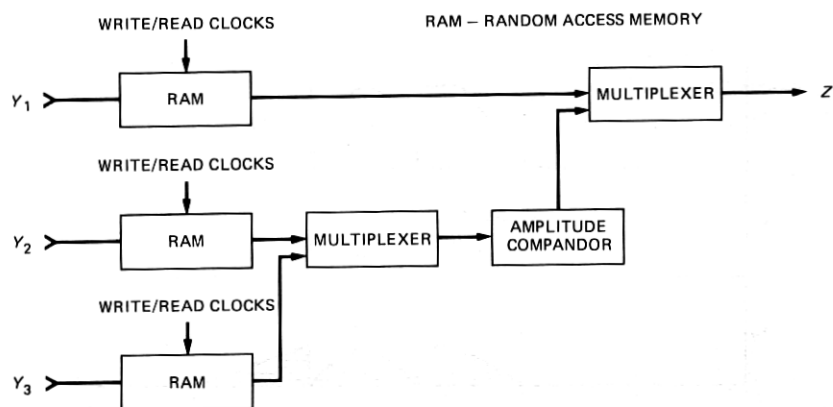

Fig. 4—The time-compression multiplexer.

write all Y_i 's into the RAMs for the field period before reading them out appropriately for multiplexing. But this would require the RAMs to accommodate entire fields of signals. Instead of this, we propose that the time compression be done over a line interval ($\approx 63.6 \mu\text{s}$) so that only line memories are needed. More specifically, let us consider a line duration T' within a T -second interval shown in Fig. 5. As before, Y_1 is the original 4.2-MHz TV; Y_2 and Y_3 are each a 2-MHz differential signal; and τ in the output Z is the processing delay. We time compress the T' -second line of Y_1 by a factor of α ($\alpha > 1$) so that the resultant signal occupies T_1 seconds ($T_1 < T'$). Likewise, Y_2 and Y_3 are both compressed by β ($\beta > 1$) so that each of their resultants occupies T_2 seconds ($T_2 < T_1 < T'$). We require that these three time-compressed signals be contained in T' , i.e.,

$$\frac{T'}{\alpha} + 2 \frac{0.83T'}{\beta} = T'. \quad (1)$$

The factor 0.83 is due to the deletion of the differential-signal horizontal blanking intervals, which are identically zero and need not be sent. The above simplifies to

$$\frac{1}{\alpha} + \frac{1.66}{\beta} = 1. \quad (2)$$

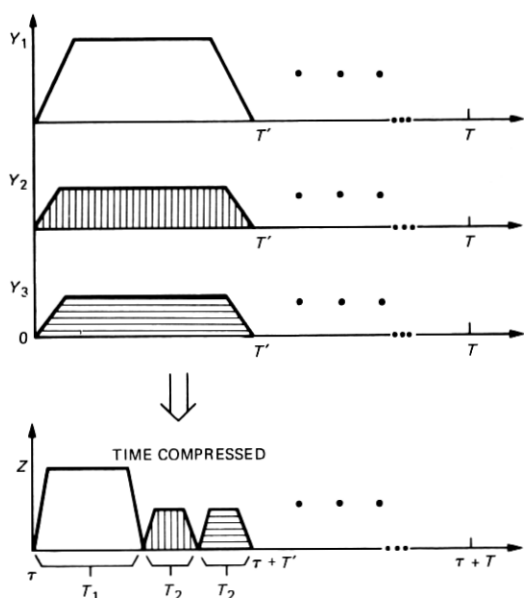

Fig. 5—Input/output waveforms for the time-compression multiplexer.

We further require that the three time-compressed signals have the same bandwidth. This can be written mathematically as⁶

$$\alpha f_1 = \beta f_2 = \beta f_3, \quad (3)$$

where f_1 , f_2 , and f_3 are the maximum frequencies of Y_1 , Y_2 , and Y_3 , respectively. In this case, $f_1 = 4.2$ MHz, $f_2 = f_3 = 2$ MHz, and the solutions to (2) and (3) are

$$\alpha \approx 1.79; \beta = 3.76. \quad (4)$$

This yields $T_1 \approx 0.56T'$ and $T_2 \approx 0.22T'$. The maximum frequency of the combined output is given by (3) and is 7.52 MHz, as compared to 12.6 MHz obtained in a straightforward TCM of the three TVs. We call the above case *optimal* because its bandwidth has been minimized by the deletion of the horizontal blanking intervals in the differential signals. One obvious drawback, however, is that the compression factors required are noninteger, as given in (4). To circumvent this difficulty, we can simply choose $\alpha = 2$ and $\beta = 4$ exactly, i.e., compressing the original signal by two and the differential parts by four, with all their horizontal blankings retained. This *practical* case is much easier to implement with a slightly larger bandwidth of 8.4 MHz.

The last, but not the least, block in the time-compression multiplexer is the amplitude compandor (Fig. 4). As pointed out previously, the differential signals are chosen such that their amplitudes are small compared to the original signal on the average. The amplitude compandor equalizes the voltage levels for the differential signals in the combined output so that the FM link performance can be maximized. This was found to be very useful in a previous experiment⁵ to suppress the effect of transmission noise on picture quality.

In summary, the present system takes in three NTSC TV signals and combines them into a 7.52-MHz (or 8.4-MHz) signal for transmission. The multiplexing technique is TCM, and the bandwidth reduction is the result of the use of differential signals. The transmission format is three fields from one TV source compressed into one ordinary field period. Thus, the transmission to the satellite is switched sequentially between the three sources at a rate equal to the field or vertical scanning frequency of ordinary NTSC TV (≈ 60 Hz). If the three TV sources are synchronized with one another, then the transmitter/multiplexer requires only three field memories. Otherwise, additional memory is needed for synchronization. In either case, the receiver requires only three field memories (see the appendix).

III. PERFORMANCE

Overall performance of time-compression multiplexing of multiple TV signals in a satellite link has never been measured experimentally.

But calculations for estimating TCM performance were shown in Ref. 1. According to these calculations, the optimal case of the present system, which has a baseband-combined bandwidth of 7.52 MHz for the three TV signals, would require a receive earth station with a Gain/Temperature (G/T) of ≈ 33.7 dB/K to yield a receive baseband TV s/n of 56 dB. Such a G/T value is obtainable from 12-meter earth stations. The practical version (8.4-MHz baseband bandwidth), on the other hand, would require a G/T of 35.9 dB/K to yield s/n = 56 dB. Such a G/T is probably not obtainable with 12-meter stations. However, the degradation in s/n by using 12-meter receive earth stations is only about 2 dB, i.e., the received s/n would be ≈ 54 dB.

IV. DISCUSSIONS

4.1 Audio

With three TV sources, each producing stereo audio, we must transmit a total of six audio waveforms. We propose sending the stereo audio from each source along with its video by inserting digital audio in either the vertical or horizontal blanking periods. As for the optimal case where the horizontal blanking periods of the differential signals are deleted in transmission, the audio signals may be included in some convenient segment of the vertical blanking period. This of course will lead to a slightly more stringent timing requirement as well as some additional buffer memory.

As for the practical case where the horizontal blankings of the differential signals are retained for transmission, then the insertion of digital audio in these blanking periods can be done quite easily. Within a group of three video lines (one unchanged original plus two differentials), there are two horizontal blankings from the differential lines available. We can use one of these two blankings for one audio and the other blanking for the other audio. Within one of these time-compressed horizontal blanking intervals ($\approx 2.7 \mu\text{s}$), we must include the audio samples from three TV scan-line durations. Now each audio signal requires sampling at ≈ 32 kHz, and with nearly instantaneous companding, 10 bits per sample are sufficient.⁷ Thus, we propose sampling the audio at exactly twice the TV line-scan rate, yielding a total of six samples or 60 bits from the three scan lines for transmission in the prescribed time-compressed horizontal blanking period. For this we would use twenty multilevel pulses to represent the 60-bit information. At a baud rate equal to $9/4 \times$ color subcarrier frequency (≈ 8.06 MHz), the six audio samples from the three lines plus another pulse for bit timing would just fill the $2.7 \mu\text{s}$ time slot.

There are several ways of mapping the 60+ bits from the three lines into twenty multilevel pulses. More discussions in this regard are

provided in Ref. 5. Because the three TV lines are from three different fields, additional memory is needed to store their audio samples, but this requirement seems trivial compared to the video counterpart.

4.2 Synchronization for multiple up-links

Use of TCM in satellite systems where up-links are not colocated requires that the three TV signals be synchronized, at least to the extent that their vertical blanking periods overlap.⁸ This condition is not very stringent compared with that of some digital Time Division Multiple Access (TDMA) systems being proposed or in operation. Other than the additional synchronization hardware required for the transmitters, the only minor imposition in the system is that the receiver be able to demodulate the FM signal subject to short discontinuities in the received carrier at the vertical scanning frequency. Conventional limiter-discriminator receivers should have no problem in dealing with this. Phaselock receivers, on the other hand, might have lockup problems. But then the system is intended for high-quality transmissions with high carrier-to-noise ratios, and threshold extension is not needed.

As an aside, let us note that if the three TV sources are transmitted through noncolocated up-links, then the processing in each transmit earth station needs only two field memories (instead of three) to generate the differential signals required. The input switches in Fig. 2 are also unnecessary. A similar saving in receiver memory is possible too if only one TV is to be received in a down-link earth station.

4.3 Extension to non-NTSC TV signals

Application of this technique to non-NTSC color TV signals may also be feasible. For example, with Phase Alternation Line (PAL) color television the color subcarrier phase is not the same as NTSC. However, with only a slight shift in the sampling pattern from line to line, the same differential signals can be defined and the same transmission system can be used. The same may be true of Sequential With Memory (SECAM) color television, but success is not as likely.

V. CONCLUSION

We have described a method to transmit three NTSC TV signals in a 36-MHz satellite transponder. The technique uses differential signals to reduce the bandwidth and Time-Compression Multiplexing (TCM) to combine the three TVs into a single signal. By the use of novel circuit configurations, the memory requirements are reduced significantly compared with the more naive approach of Ref. 1. By companding the differential signals, the effect of transmission noise on

picture quality is markedly reduced. The estimated performance of the system is at or close to broadcast quality if 12-meter earth stations were to be used in a satellite system such as COMSTAR. Finally, digital audio signals can be sent without interference either to or from the video TCM signal by placing it in the horizontal blanking period. Extensions to up-links from separate earth stations and non-NTSC TVs are also possible.

REFERENCES

1. K. Y. Eng and B. G. Haskell, "TV Bandwidth Compression Techniques Using Time Companded Differentials and Their Applications to Satellite Transmissions," *B.S.T.J.*, 61, No. 10, Part 1 (December 1982), pp. 2917-27.
2. J. E. Flood and D. I. Urquhart-Pullen, "Time-Compression-Multiplex Transmission," *Proc. IEE*, 111, No. 4 (April 1964), pp. 647-68.
3. D. H. Morgen and E. N. Protonotarios, "Time Compression Multiplexing for Loop Transmission of Speech Signals," *IEEE Trans. Commun.*, COM-22, No. 12 (December 1972), pp. 1932-9.
4. B. G. Haskell, "Time-Frequency Multiplexing of Two NTSC Color Signals—Simulation Results," *B.S.T.J.*, 60, No. 5 (May-June 1981), pp. 643-60.
5. R. L. Schmidt and B. G. Haskell, "Transmission of Two NTSC Color Television Signals Over a Single Satellite Transponder Via Time-Frequency Multiplexing," *Globecom '82 Conf. Rec.*, 1, pp. B6.3.1-5.
6. K. Y. Eng and O. Yue, "Spectral Properties and Band-Limiting Effects of Time-Compressed TV Signals in a Time-Compression Multiplexing System," *B.S.T.J.*, 60, No. 9 (November 1981), pp. 2167-85.
7. M. G. Croll et al., "Nearly Instantaneous Digital Compressor for Transmitting Six Programme Signals in a 2.048 Mbit/s Multiplex," *Electron. Lett.* (July 12, 1973), pp. 298-300.
8. Kai Y. Eng and B. G. Haskell, "Synchronization of Noncolocated TV Signals in a Satellite Time-Compression Multiplexing System," *B.S.T.J.*, this issue.

APPENDIX

Decomposition of the TCM Signal From Three Video Sources

As Fig. 6 shows, the received FM signal from the satellite is demodulated to recover the TCM baseband waveform. It is then digitized to produce Z' , which would be identical to Z previously except for the transmission noise and channel distortion added. An amplitude compander undoes the companding done to the composite waveform. Now the three segments in this waveform, namely the original field and the two differential signals, are then separated by the demultiplexer and written onto three separate memories. They are read out at slower speeds to get time expanded to the full scan-line length. The expansion factors (ratio of write clock to read clock) are precisely the compression factors used in the transmitter. Approximations to Y_1 , Y_2 , and Y_3 , denoted here by Y'_1 , Y'_2 , and Y'_3 , are then obtained. The same predictor as in the transmitter is used to convert the differential signals into the originals. The three output switches, S_4 , S_5 , and S_6 , move in synchronism from the top position to the middle, to the bottom, and back to the top, etc. Their operations are identical to S_1 ,

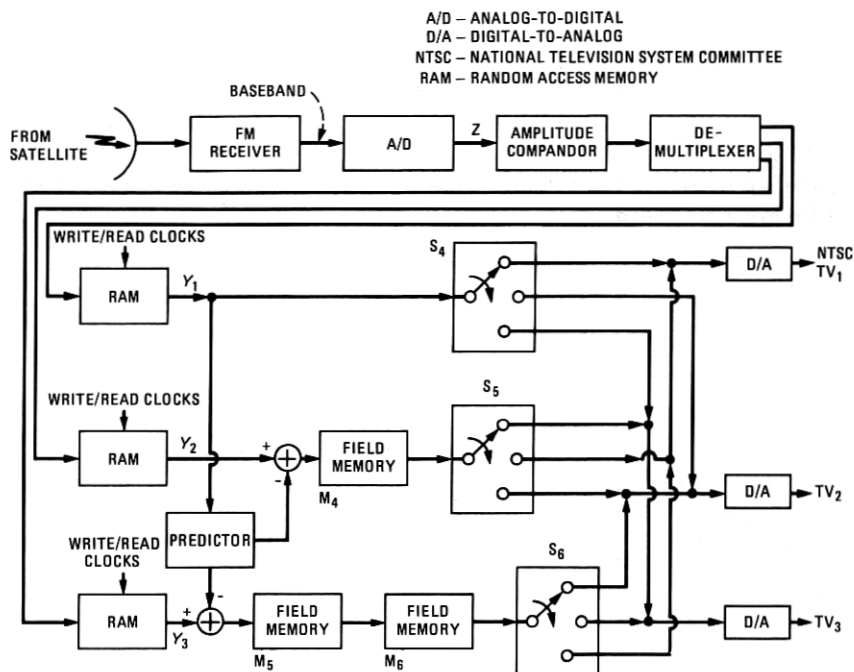

Fig. 6—Receive earth station for three TVs per transponder.

S_2 , and S_3 in the transmitter, and they route the output digital signals to their appropriate outputs. The output digital signals may (or may not) then be converted to analog signals for display or local distribution.

AUTHORS

Kai Y. Eng, B.S.E.E. (summa cum laude), 1974, Newark College of Engineering; M.S. (Electrical Engineering), 1976, Dr. Engr. Sc. (Electrical Engineering), 1979, Columbia University; RCA Astro-Electronics, 1974-1979; Bell Laboratories, 1979—. Mr. Eng has worked on various areas of microwave transmission, spacecraft antenna analysis, and communications satellites. He is presently a member of the Radio Research Laboratory, studying TV transmission through satellites. Member, IEEE, Sigma Xi, Tau Beta Pi, Eta Kappa Nu, Phi Eta Sigma.

Barry G. Haskell, B.S. (Electrical Engineering), 1964, M.S., 1965, and Ph.D., 1968, University of California, Berkeley; University of California, 1965-1968; Bell Laboratories, 1968—; Rutgers University, 1977-1979. Mr. Haskell was a Research Assistant at the University of California Electronics Research Laboratory and a part-time faculty member of the Department of Electrical Engineering at Rutgers University. At Bell Laboratories, he is presently Head of the Radio Communications Research Department, where his research

interests include television picture coding and transmission of digital and analog information via microwave radio. Member, IEEE, Phi Beta Kappa, Sigma Xi.

Robert L. Schmidt, B.S.E.E., 1982, Monmouth College; Bell Laboratories, 1972—. Mr. Schmidt is currently a member of the Radio Communications Research Department, where he has been exploring various techniques in combining multiple television signals onto a single analog radio channel. He has researched television signal encoding, bit rate reduction techniques, and software-controlled coding systems. Member, Eta Kappa Nu.

