

## A Subjective Comparison of Selected Digital Codecs for Speech

By W. R. DAUMER and J. R. CAVANAUGH

(Manuscript received March 28, 1978)

*Technological advances are continually increasing the economic viability of efficient codecs in telephone networks. A subjective evaluation is described here of the  $\mu$ 255 Pulse Code Modulation (PCM) algorithm and three more efficient techniques, Nearly Instantaneous Companding PCM (NIC PCM), Cummiskey-Jayant-Flanagan Adaptive Differential PCM (ADPCM), and Subscriber Loop Carrier Adaptive Delta Modulation (SLC\* ADM). These codecs are compared under the conditions of: (i) single encodings as a function of line bit rate, input level, received volume, and error rate, (ii) tandem encodings with intermediate baseband conversion, and (iii) local, exchange, and toll network reference connections where mixed tandem encodings might be found along with typical analog impairments such as loss and random noise. The simulation of the codec algorithms on a minicomputer facility enabled the production of subjective test tapes containing speech processed under these conditions. These tapes were then evaluated in listening-type subjective tests. It is shown that (i) NIC PCM, ADPCM, and SLC ADM have approximately a 12- to 16-kb/s advantage over  $\mu$ 255 PCM for equivalent subjective ratings, (ii) NIC PCM, ADPCM, and SLC ADM perform comparably over the range of conditions tested; and (iii) 64-kb/s  $\mu$ 255 PCM can be deployed in a multiple encoding environment with very few restrictions, whereas the use of lower bit rate NIC PCM, ADPCM, and SLC ADM codecs would necessitate more stringent application rules to avoid excessive degradation in tandem encoding situations.*

---

\* Trademark of Western Electric.

## I. INTRODUCTION

In recent years, a great amount of interest has been expressed in the literature on the subject of efficient encoding of voiceband signals. Much of this interest stems from the economics of bandwidth reduction that are possible with efficient codecs. Waveform codecs such as differential PCM (DPCM), adaptive differential PCM (ADPCM), delta modulation (DM), and adaptive delta modulation (ADM) are considered for general use in telephone networks because, among other reasons, they often are a reasonable compromise between the bandwidth required of the transmission channel and the terminal complexity at the ends of the channel.

Aside from the economics, there is the issue of degradations introduced by a codec in speech and voiceband signals. In fact, a signal may undergo a number of encodings by codecs of different types as it progresses through the network. An example of this is the hypothetical network of Fig. 1. Here, a mixture of analog and digital switching and transmission facilities are represented.

The toll portion of the network incorporates analog toll switches such as the No. 4 crossbar and the digital No. 4 ESS switch. The D channel banks and VIF terminals are shown in order to point out where analog-

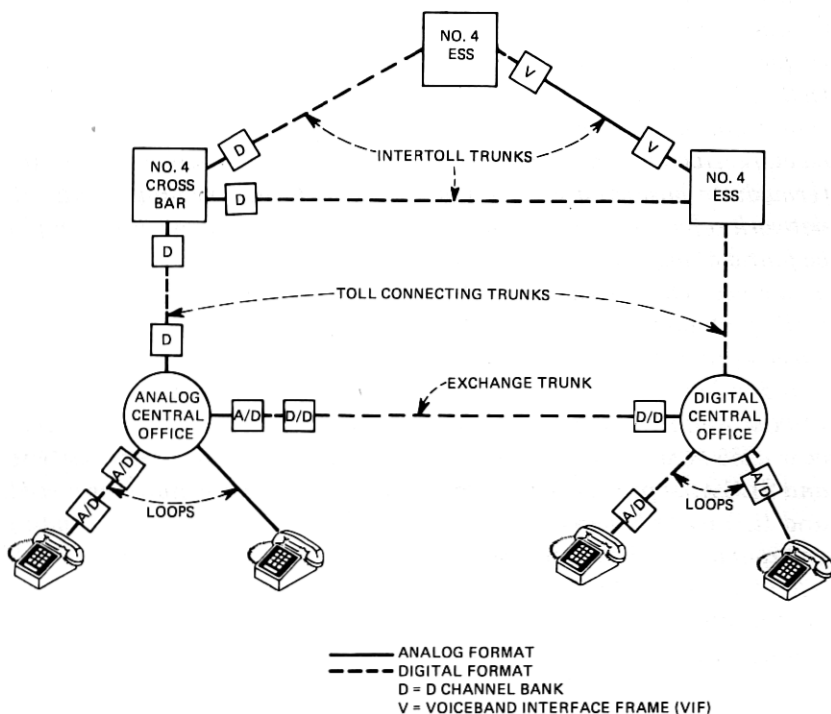

Fig. 1—Possible codec deployment in DDD network.

to-digital conversions take place. The coding law currently used in Bell System D channel banks is 64-kb/s  $\mu$ 255 PCM.<sup>1</sup>

The exchange network environment favors the deployment of efficient codecs because of the investment in the exchange and loop plants. Subscriber carrier and remote switching systems may be installed on loops and interfaced directly to a digital central office. Other carrier systems may be implemented by a digital-to-digital (D/D) conversion from one code format to another more efficient format as shown in the exchange trunk example of Fig. 1.

The point is that a telephone call can be routed over a variety of connections in this network and might be subjected to 64-kb/s  $\mu$ 255 PCM encodings in the toll plant in tandem with other codecs found in the local environment. The goal of the studies reported in this paper is to gain insight into the subjective effects of a multiple encoding environment on speech. Another important component of this goal is the impact of this environment on voiceband data. However, the resources and time consumed by the speech studies did not allow simultaneous work on voiceband data in the context of this study.

Prior to the evaluation of the overall subjective effect of a network environment on speech, the contributions of the various components of the network must be well understood. The analog components can be represented by transmission impairments such as loss and additive random noise.<sup>2</sup> The performance of a digital component of a connection is a function of the quantizing noise characteristics of the digital encoding, the line bit rate, the speech input level to the codec, and transmission impairments such as bit errors, slips, and misframes. The initial step of the study concentrated on the evaluation of some of these impairments for single encodings by selected codecs. Next, the codecs were tandemed with themselves under controlled conditions in order to establish the multiple encoding behavior without the complications of more than one coding law. Finally, selected codecs were incorporated into a set of reference network connections. These reference connections are representative of Bell System local and toll connections with characteristics (loss, noise, talker volume) that are derived from survey data.

The purpose of this paper is to report on recently completed subjective tests of digital codecs. Detailed results of the tests are presented and preliminary analyses are discussed. However, another objective of these tests is to provide a sufficiently large data base to enable the development of analytic models of subjective behavior. These models would be used to predict the performance resulting from the introduction of digital codecs in an evolving telephone network.

## II. CODEC ALGORITHMS

Four basic codec algorithms were evaluated: (i)  $\mu$ 255 PCM,<sup>3,4</sup> (ii) Nearly Instantaneous Companding (NIC) PCM,<sup>5</sup> (iii) Cummiskey-Jayant-Flanagan ADPCM,<sup>6</sup> and (iv) Subscriber Loop Carrier (SLC\*) ADM.<sup>7</sup> These four were chosen for one or more of the following reasons: interest in the algorithm, availability of a well-defined software algorithm in the time frame of these tests, total number of test conditions to be generated, and the existence of a hardware implementation of the codec. These codecs are samples of four different classes of waveform codecs, but each chosen codec is quite specific and the reader is cautioned against generalizing the results for a particular codec to an entire class of codecs. Note that NIC PCM, ADPCM, and SLC ADM employ adaptive quantization (or companding) but none of the codecs incorporates adaptive prediction.

A brief description of some of the characteristics of each algorithm is given here which, in conjunction with the references, should aid the reader in understanding the similarities and differences among the algorithms when the results are discussed.

### 2.1 $\mu$ 255 PCM

Three versions of the  $\mu$ 255 PCM algorithm were included in the tests: the continuous law compandor<sup>3</sup> with a mid-tread bias and the 15-segment version<sup>4</sup> of the  $\mu$ 255 compandor with both a mid-tread and a mid-riser bias. However, most of the attention is focused on the 15-segment mid-tread algorithm, since this algorithm at 64 kb/s is used in Bell System D channel banks.<sup>†</sup> Since the idle channel noise of a mid-tread algorithm implemented on a computer is essentially nonexistent, 16 dBmC0 of random noise is introduced at the outputs of both mid-tread algorithms. This level of noise is intended to represent that which could be achieved in a hardware implementation. The overload point in all three cases is set at the peak amplitude of an inband sine wave with an rms power of +3 dBm0.

### 2.2 NIC

This algorithm is a block encoding scheme<sup>5</sup> which compresses  $L$ -bit, 15-segment  $\mu$ 255 PCM ( $L \geq 4$ ) to  $L - 2$  bits. In this application, there are eight samples to a block. The largest segment number in the block is found and transmitted to the far-end decoder. The eight  $L$ -bit  $\mu$ 255 samples are then digitally reencoded into  $L - 2$  bit uniform samples with an overload point at the top of the largest segment in the block. This yields a bit rate of  $[8 \times (L - 2) + 3]$  kb/s for an 8-kHz sampling rate, where the 3-kb/s component represents the transmission of the maxi-

\* Trademark of Western Electric.

† Except for older D1 channel banks, where 56-kb/s  $\mu$ 100 PCM is used.

imum segment number in the block every millisecond. The NIC algorithm is biased mid-tread for  $L \geq 7$  bits and mid-riser for  $L \leq 6$  bits. As in the PCM algorithms described above, 16 dBmC0 of noise is added to the decoder output during mid-tread operation, and the overload point is set at +3 dBm0.

### 2.3 ADPCM

The Cummiskey-Jayant-Flanagan ADPCM algorithm<sup>6</sup> was chosen using a first-order predictor in the feedback loop with a time constant of 0.43 ms. For line bit rates greater than or equal to 32 kb/s ( $L \geq 4$  bits/sample at 8-kHz sampling), the minimum quantizer step size is equal to twice the interval on the first chord of the 8-bit  $\mu 255$  PCM quantizer. For  $L < 4$ , the minimum step-size is increased by the factor  $(5 - L)$  over the step-size for  $L \geq 4$ . For all values of  $L$ , the ratio of the maximum step-size to the minimum step-size is 128, identical to the 8-bit  $\mu 255$  PCM algorithm. No amplitude overload point was set for this algorithm, since it is a differential codec, but for  $L = 4$  the algorithm is driven into slope overload with a 425-Hz sine wave at +6 dBm0. A modification of this algorithm was also investigated to determine the subjective effect of line bit errors. This modification was the introduction of step-size leak into the step-size adaptation logic. Normally,

$$\Delta_i = a_i \Delta_{i-1},$$

where  $\Delta_i$  is the quantizer step-size at a particular sample interval  $i$  and  $a_i$  is the corresponding adaptation coefficient. An error in the transmission of the bit stream to the decoder will cause an error in the decoder step-size adaptation. The effect of bit errors can be minimized somewhat by the addition of step-size leak, so that

$$\Delta_i = a_i (\Delta_{i-1}) \gamma,$$

where  $\gamma$  is less than but nearly equal to unity. In our application,  $\gamma$  is chosen to be 31/32. This limits the effect of an error at the decoder so that the encoder and decoder step-sizes eventually track each other. However, the adaptation process remains affected by the step-size leak in the absence of errors, and discernible distortion may be introduced into the speech.

### 2.4 SLC ADM

The ADM algorithm chosen was the SLC-40 algorithm.<sup>7</sup> It is currently deployed at a sampling rate of 37.7 kHz in a 40-channel loop carrier system. Of the three non-PCM coding schemes described in this section, it is the only one in commercial use in the Bell System, with approximately 1800 systems installed in the field to date. This algorithm uses an adaptive step-size where the step-size is altered whenever four suc-

cessive like sign bits are transmitted on the line. The predictor in the feedback loop has a main time constant of 0.7 ms. The minimum step-size is set to achieve an idle channel noise of 15.5 dB<sub>BrnC0</sub> at 37.7 kb/s. This codec is driven into slope overload with a +6 dB<sub>m0</sub> input sine wave at a frequency of 800 Hz.

### III. SIMULATION SYSTEM

#### 3.1 Overview of system

A minicomputer facility which was developed at Bell Laboratories in Holmdel, N.J., is briefly described in this section. A detailed description of its capabilities and operation can be found in Ref. 8.

This system has four important characteristics: (i) the system configuration is independent of any particular codec algorithm; (ii) the system is conducive to experimentation and development of a desired codec algorithm; (iii) the system is capable of simulating a network connection containing mixed tandem encodings of several codecs; and (iv) the system is capable of automatic production of audio tapes suitable for subjective evaluation. All the codec test conditions discussed in this paper were simulated on this system.

Two PDP\*-11 minicomputers are interfaced with uniform 15-bit A/D and D/A converters. The system is capable of real-time operation at sampling rates up to 72 kHz. A particular codec algorithm can be implemented on this system as long as the sampling rate of the codec is less than 72 kHz; the codec distortion dominates the 15-bit A/D and D/A converter distortion; and differences between hardware and software versions of the codec are recognized and accounted for.

#### 3.2 Hardware configuration

Referring to Fig. 2, PDP 11/40 and 11/20 minicomputers are used, each having 28K words (16 bits/word) of memory. Each minicomputer is interfaced to a dedicated Tustin series 1500 A/D and D/A converter system. The A/D and D/A converter systems were measured and adjusted to ensure that they were capable of at least theoretical 14-bit accuracy so that the waveform codecs of Section II could be simulated.

A 1.25-million-word disk system was installed on each machine with a nine-track tape drive interfaced on the 11/40 for mass storage. The tape format is standard, so that large amounts of data can be transferred to other more powerful computer facilities for processing. An Ampex AG-440G analog tape unit is also controlled by the 11/40 so that high-quality audio tapes can be automatically prepared for subjective testing.

In addition to the dedicated equipment on each processor, there is a UNIBUS\* window between the two machines to allow interprocessor

\* Registered trademark of Digital Equipment Corporation.

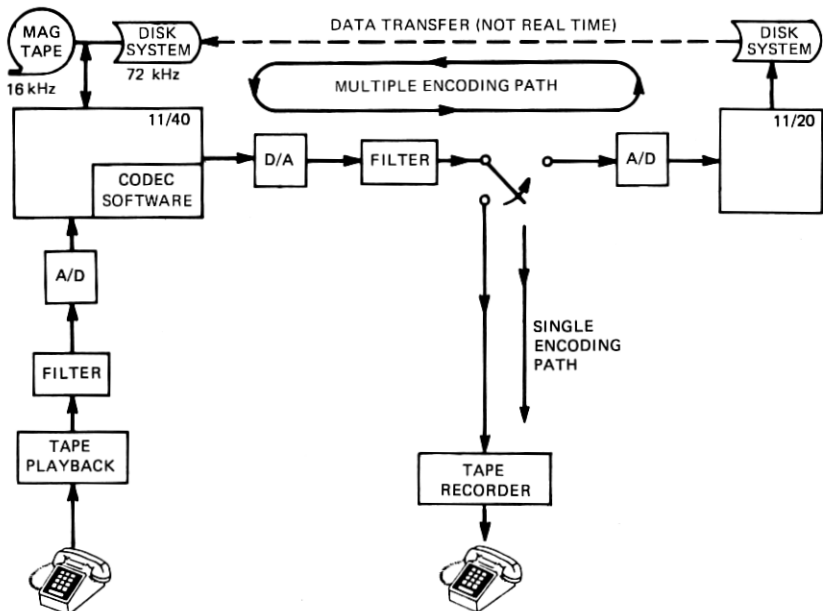

Fig. 2—Codec simulation facility.

communication and data transfer. This equipment is essential for the automatic generation of tandem encodings.

### 3.3 Facility operation

Referring to the lower left-hand portion of Fig. 2, a segment of an analog signal such as speech is derived from a tape recorder, telephone set, or other source. The signal is bandlimited, quantized, and stored on either tape or disk. The choice of tape or disk is determined from two considerations, the sampling rate of the A/D converter and the length of the analog segment to be digitized. The disk can store samples at rates up to 72 kHz, the magnetic tape up to 16 kHz. However, a 2400-foot tape reel can store 10 million words, the disk only 1.25 million words.

After the digits are stored on either tape or disk, they can be processed by a codec algorithm and stored back on magnetic tape or disk in preparation for playback. The output signal of the D/A converter is passed through a reconstruction filter and the codec simulation is essentially completed. The resultant analog signal can be stored on an audio tape recorder as indicated by the "single encoding" path in Fig. 2.

If a tandem encoding is to be simulated, the "switch" following the reconstruction filter is positioned to the input of the A/D converter of the 11/20. As the playback operation is proceeding on the 11/40, a simultaneous acquisition process is proceeding at the 11/20. The D/A on

the 11/40 and the A/D on the 11/20 can be timed by independent clocks. Hence, the overall D/A-A/D process can be performed asynchronously. After the acquisition at the 11/20 is complete, the 11/40 retrieves the samples from the disk system of the 11/20 via the UNIBUS window. The samples then reside on the magnetic tape unit or disk system of the 11/40. A second codec processing can take place in an identical manner as described above. A tandem encoding loop is thus defined. This loop is illustrated in the upper portion of Fig. 2. A signal can be made to traverse this loop as many times as desired, with no restrictions on sampling rate or codec type for each successive encoding. When the desired number of tandem encodings are completed, the signal can be stored on audio tape as in the single encoding case. Both the single and tandem encoding operations are performed under the automatic control of the software. Manual intervention after each loop is not necessary.

#### **IV. SUBJECTIVE TESTING—TECHNIQUES**

The subjective tests described in this paper were all conducted as listening-only tests (not conversational). The subjects listened to pre-recorded speech and voted on the perceived quality. Details concerning the test facilities, selection of subjects, test circuitry, and test administration are covered in this section.

##### **4.1 Description of tests and facilities**

The subjective tests were conducted in an acoustically treated test room containing 11 cubicles permitting up to 11 subjects to be tested simultaneously. Each cubicle contains a handset over which test conditions are heard and a keyboard with five keys labeled "excellent," "good," "fair," "poor," and "unsatisfactory," which is used for registering the vote for each test condition. Associated with the keyboard are red indicator lights which are lit during the presentation of a test condition and green indicator lights which are lit to indicate the period for voting on the test condition.

The votes of each subject are recorded using a minicomputer system, a keyboard interface, and associated programs. A terminal permits monitoring of the ratings during the tests. All votes are recorded on magnetic tape for subsequent analysis.

At the start of the test session, a start signal is sent by the test administrator to the computer which then remotely actuates the tape recorder and turns on the red keyboard lights. At the end of each test condition, a tone recorded on the second track of the test tape is recognized by a tone detection circuit which signals the computer to stop the recorder and turn on the green voting lights. The computer then collects the votes. After all the votes are received from the subjects or after a 3-second timeout period (whichever occurs first), the computer extin-



guishes the green voting lights, turns on the red keyboard lights, and then starts the tape recorder for the next test condition.

#### **4.2 Test playback system**

The system used for the subjective tests is shown in Fig. 3. A dual-track tape recorder (Ampex 440G) equipped with a Dolby noise reduction unit is used to drive a standard 500-type telephone set (with a receiving rating efficiency of 21 dB) connected to 6 kft of 26-gauge, nonloaded cable and a 400-ohm, 48-Vdc feeding bridge (central office battery supply circuit). The carbon transmitter is replaced with a 90-ohm resistor to eliminate any room noise pickup. The master telephone set receiver is replaced by a 120-ohm resistor to avoid possible introduction of acoustic/inductive interference in the test conditions; a transformer-amplifier bridge on this resistor drives the 11 telephone set receivers in the cubicles as shown in Fig. 3.

The measured responses of the playback system are shown in Figs. 4 and 5. These responses reflect adjustment of the listening amplifier such that a speech level of  $-29$  VU (volume units) at the line terminals of the telephone set (point  $V_2$  of Fig. 3) produces an acoustic pressure of  $-12$  dBPa\* (82 dB relative to  $20 \mu\text{Pa}$ ) for speech power averaged across the 11 receivers. The value of  $-12$  dBPa approximates the preferred speech pressure level.

#### **4.3 Subject selection and test administration**

Subjects were selected from employees in various job classifications and age groups at Bell Laboratories in Holmdel, N.J. The sheer number of test conditions dictated that the total test program be divided into five tests. All the tests were administered independently of one another using different subjects. The number of subjects and breakdown according to sex is given in Table I. Discussions of the testing throughout the remainder of this paper will be structured under the three topics of (i) single encodings, (ii) tandem encodings, and (iii) the local, exchange, and toll reference connections.

For each test session, a maximum of 11 test subjects were seated in the test cubicles and supplied with test instructions shown in Fig. 6. The test administrator read the instructions and told the subjects that there would be four practice test conditions given before the start of the test. The subjects were told to vote on the four practice conditions as if they were part of the actual test. After the practice conditions were presented and voted on, the test administrator would enter the test room to answer any questions before the actual testing began.

\* dBPa = dB relative to 1 Pascal which corresponds to 1 newton per square meter.

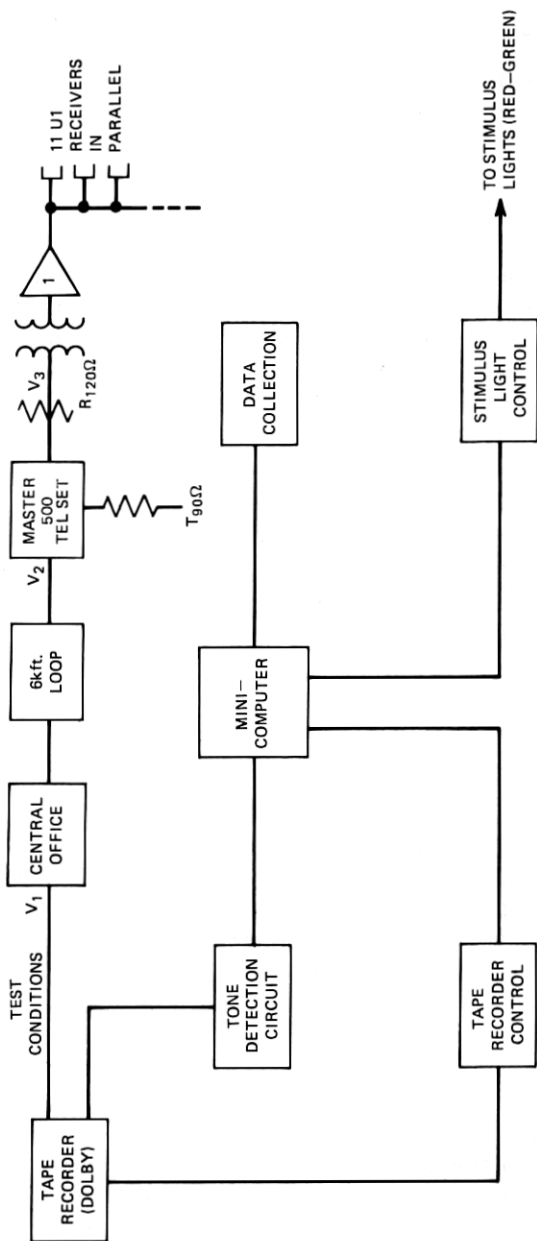

Fig. 3—Multiple listening playback system.

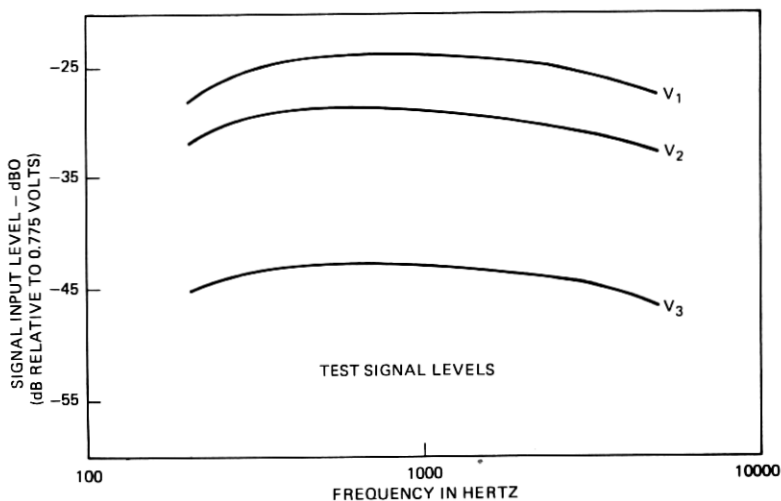

Fig. 4—Test signal levels.

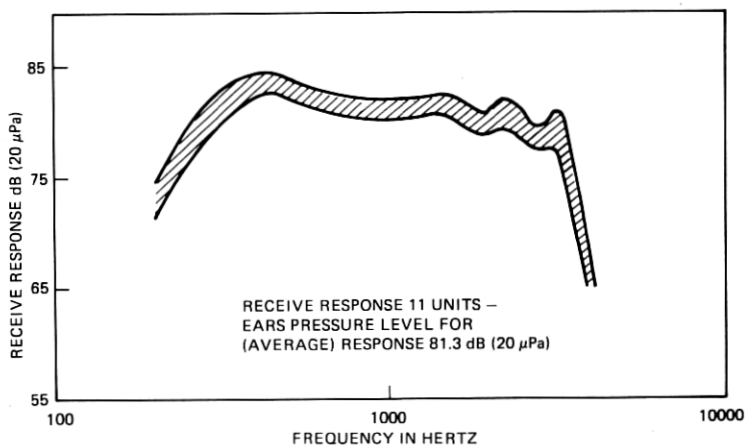

Fig. 5—Response measurements for playback system.

#### 4.4 Speech sources and anchoring conditions

The source tapes were made by recording male and female speech from the output of a 500-type telephone set carbon transmitter through a 111C repeater coil and a simulated 6-kft loop using a Dolby noise reduction unit. These sources were then processed by the various codec algorithms to produce the test conditions.

Analog noise conditions were included in each test session along with codec conditions. The analog noise conditions were generated by adding white noise bandlimited from 200 Hz to 3.4 kHz to the speech so that, with the speech level set at -29 VU at the 500-type telephone set terminals, the noise is at a level of 10, 20, 30, or 40 dB<sub>BrnC</sub>. The inclusion of

Table I—Number of subjects

Test	Total	Male	Female
(i) Single Encodings—Variation of Line Bit Rates and Levels	51	37	14
(ii) Single Encodings—Error Rate	52	35	17
(iii) Tandem Encodings plus Local and Exchange Reference Connections	53	49	4
(iv) Toll Reference Connections—Part 1	56	46	10
(v) Toll Reference Connections—Part 2	54	50	4

THIS EXPERIMENT IS DESIGNED TO STUDY THE EFFECTS OF VARIOUS IMPAIRMENTS ON TELEPHONE TRANSMISSION QUALITY. YOUR TASK IS TO LISTEN TO THE TEST CONDITIONS AND, AFTER EACH CONDITION, MAKE A JUDGMENT OF THE TRANSMISSION QUALITY. A JUDGMENT CAN BE MADE IN ONE OF FIVE CATEGORIES: EXCELLENT, GOOD, FAIR, POOR, AND UNSATISFACTORY.

THE EXPERIMENT WILL CONSIST OF TWO PARTS, EACH CONTAINING TEST CONDITIONS, WITH A REST PERIOD BETWEEN THE TWO PARTS. THE TOTAL TIME OF THE TEST WILL BE ABOUT 60 MINUTES.

WHEN THE SIGNAL IS GIVEN, PLEASE PICK UP THE WHITE PRINCESS® TELEPHONE HANDSET IN FRONT OF YOU AND HOLD IT TO YOUR TELEPHONE LISTENING EAR. FOR EACH TEST CONDITION, YOU WILL HEAR THREE SENTENCES. AT THE END OF THE SENTENCES, A GREEN LIGHT ON THE KEYBOARD IN FRONT OF YOU WILL BE LIGHTED. DURING THE TIME THE GREEN LIGHT IS LIGHTED, YOU ARE TO RATE THE TRANSMISSION QUALITY OF THE TEST CONDITION YOU JUST HEARD BY PUSHING ONE OF THE FIVE MARKED BUTTONS ON THE KEYBOARD AS FOLLOWS: EXCELLENT, GOOD, FAIR, POOR, AND UNSATISFACTORY.

PLEASE FILL OUT THE CARD IN FRONT OF YOU.

ARE THERE ANY QUESTIONS?

Fig. 6—Test instructions.

these noise conditions allowed the codec results to be referenced or anchored into the body of information that has been accumulated over the years on the effects of random noise. It is estimated that the background noise contribution from the original source tape was approximately 4 dBrnC measured at the line terminals of the telephone set.

Speech-correlated noise conditions were included because they approximate  $\mu$ 255 PCM quantizing noise and can be utilized in future modeling efforts. These conditions were produced by a device called the Modulated Noise Reference Unit (MNRU).<sup>9</sup> This introduces a noise signal to the input speech, which is directly correlated to the instantaneous amplitude of the speech. The speech-correlated noise conditions were designated  $Q = 5$ ,  $Q = 10$ , etc., where  $Q$  is equal to the decibel value of the ratio of the speech power to speech correlated noise power.

In addition to the reasons given above, the analog noise and  $Q$  conditions served as control conditions by being included in every test session as a check on session-to-session differences.

#### 4.5 Analysis of results

The votes from each test condition are combined into a vote histogram with the votes for male and female speech pooled together. These histograms contain the number of votes recorded for each of the comment categories "excellent," "good," "fair," "poor," and "unsatisfactory" as represented by the category numbers 5, 4, 3, 2, and 1, respectively. A Mean Opinion Score (MOS) is calculated for each test condition by taking the arithmetic mean of the category numbers voted. A sample standard deviation ( $\sigma$ ) is also calculated for each vote histogram.

The male and female results are combined because a simple regression analysis of the data indicated that there was little difference between the subjective responses for male and female speakers (about 0.2 to 0.4 of a category point). The overall standard deviation of the data is on the order of 0.6 to 0.7 of a category point.

#### V. SUBJECTIVE TESTING—SINGLE ENCODINGS

The first round of subjective testing involves single encodings of  $\mu$ 255 PCM, NIC, ADPCM, and SLC ADM as a function of three parameters; line bit rate, input level and received volume (listening level) pairs, and line error rate.

##### 5.1 Test design

Table IIA lists the test conditions as a function of line bit rate. Three

Table IIA—Single encoding versus line bit rate conditions

Algorithm	Bit Rate (kb/s)
Continuous Law PCM (mid-tread bias)	16,40,64
15-Segment PCM (mid-tread bias)	32,40,48,64
15-Segment PCM (mid-riser bias)	32,48
NIC PCM	19,35,43,51,59
ADPCM (with step-size leak)	16,24,32,40,48
ADPCM (without step-size leak)	16,24,32,48
SLC™ ADM	24,37.7, 48

Table IIB—Single encoding versus level variation conditions

Algorithm	Bit Rate (kb/s)
15-Segment PCM (mid-tread bias)	48
NIC PCM	51
ADPCM (with step-size leak)	48
SLC™ ADM	48

Input Level (VU)	Received Volumes (VU)
-0.2	-20.7,-29.0
-10.5	-20.7,-29.0,-38.3
-20.7	-29.0,-38.3
-31.0	-38.3
-41.2	-47.0

Table IIC—Single encoding versus error rate conditions

Algorithm	Bit Rate (kb/s)
15-Segment PCM (mid-tread bias)	48
NIC PCM	51
ADPCM (with step-size leak)	48
SLC™ ADM	48

versions of the  $\mu$ 255 PCM algorithm are included mainly for verifying that the subjective differences between continuous law, 15-segment mid-tread, and the 15-segment mid-riser algorithms are negligible. ADPCM is simulated with and without step-size leak. To economize on the total number of test conditions, various line bit rates are excluded with care taken so that subjects are exposed to a wide subjective quality range and the subjective ratings of these exclusions can be estimated by interpolation. The input speech level for these conditions is  $-24.8$  VU ( $\sim -23.4$  dBm), the average reported by McAdoo<sup>10</sup> for local calls over the Bell System message network. The measured idle channel noise of each codec is given in Table III. The received volume presented to the subject is  $-29$  VU, measured at the line terminals of the telephone set.

The conditions for single encoding as a function of input level and received volume are arrived at by estimating Bell System speech volumes and network losses for five types of network connections: (i) intra-building, (ii) interbuilding over a direct trunk, (iii) interbuilding over two tandem trunks, (iv) and (v) long and short connections over the intertoll network. For each of these five situations, the encoder and decoder of a codec are postulated to be located in the telephone set, end office, and at an intermediate point in the loop as in the example of a remote switching or pair gain system. Speech volume<sup>10</sup> and loss<sup>11</sup> distributions are used to derive the input level and received volume ranges to be tested. A condition is then defined by quantizing these ranges and assigning input level-received volume pairs to a codec where the received volume is always less than the input level. The four codecs are implemented at a single bit rate which is equal to 48 kb/s or as close to 48 kb/s as possible (51 kb/s in the case of NIC). This particular line bit rate is chosen for two reasons: (i) the large number of possible test conditions to be evaluated dictated the use of a single line bit rate, and (ii) that line bit rate should be 48 kb/s since experience has shown that the distortion introduced by a single encoding of  $\mu$ 255 PCM at 48 kb/s can be barely perceived and it is desirable to ascertain and compare the performance of the other codecs at a comparable line bit rate. Table IIB lists the codecs and the input level-received volume matrix used in this section of testing.

The third and final portion of the single encoding tests is concerned with the subjective effect of random transmission errors. Independent errors are introduced between the encoder and decoder at rates  $10^{-1}$ ,

$10^{-2}$ ,  $10^{-3}$ ,  $10^{-4}$ , and  $10^{-5}$  errors/bit. The four codecs are chosen to operate at a line bit rate equal to or nearly 48 kb/s for the same reasons given in the previous paragraph. The input level is set at  $-12.4$  VU so that the entire dynamic range of the PCM and NIC codecs is exercised without overloading. A summary of the error rate test conditions appears in Table IIC.

## 5.2 Results and observations

The combined results for single encodings as a function of line bit rate, input level and received volume, and line error rate are given in the appendix, Tables V, VI, and VII, respectively. Most of these tabulated results are summarized in Figs. 7 through 10.

Figure 8 is a plot of the mean opinion score (MOS) versus line bit rate for the codecs of Table IIA. It is recalled that these results are obtained using an input speech level of  $-24.8$  VU with a received volume of  $-29$  VU, representing a 4.2-dB loss located after the decoder. An immediate observation that can be drawn is the subjective advantage of all the adaptive codecs (NIC, *SLC* ADM, and ADPCM) over the  $\mu$ 255 PCM. Below a line bit rate of 48 kb/s, this advantage is on the order of 12 to 16 kb/s for equivalent subjective ratings. At 48 kb/s and above, the leveling off of the response curves is due to two effects. The first important factor is the absolute level of idle channel noise the subjects hear. The idle

Table III—Single encoding idle channel noise measurements

Algorithm	Bit Rate (kb/s)	Idle Channel Noise (dBrnC)
True Logarithmic PCM (mid-tread)	16	16.0
True Logarithmic PCM (mid-tread)	40	16.0
True Logarithmic PCM (mid-tread)	64	16.0
15-Segment PCM (mid-riser)	32	37.7
15-Segment PCM (mid-riser)	48	26.3
15-Segment PCM (mid-tread)	32	16.0
15-Segment PCM (mid-tread)	40	16.0
15-Segment PCM (mid-tread)	48	16.0
15-Segment PCM (mid-tread)	64	16.0
NIC PCM	19	31.4
NIC PCM	35	19.6
NIC PCM	43	16.0
NIC PCM	51	16.0
NIC PCM	59	16.0
ADPCM (with step-size leak)	16	27.1
ADPCM (with step-size leak)	24	23.1
ADPCM (with step-size leak)	32	18.6
ADPCM (with step-size leak)	40	18.4
ADPCM (with step-size leak)	48	18.4
ADPCM (without step-size leak)	16	25.2
ADPCM (without step-size leak)	24	22.3
ADPCM (without step-size leak)	32	18.7
ADPCM (without step-size leak)	48	18.4
<i>SLC</i> ADM	24	23.3
<i>SLC</i> ADM	37.7	15.5
<i>SLC</i> ADM	48	13.3

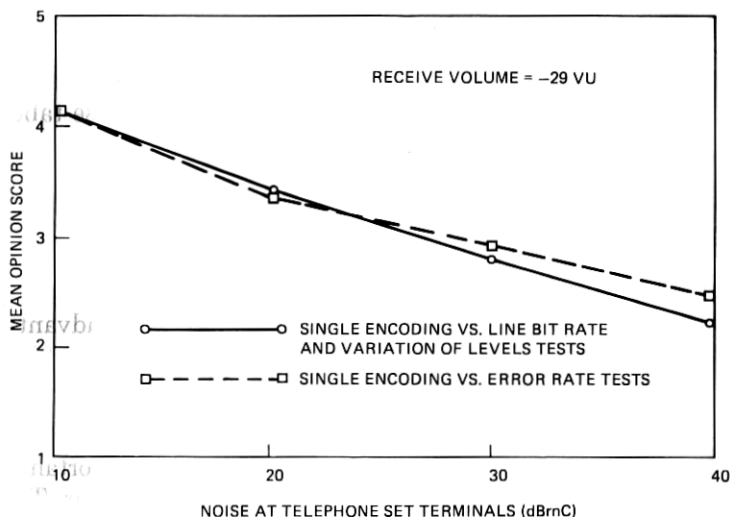

Fig. 7—Subjective results—additive random noise.

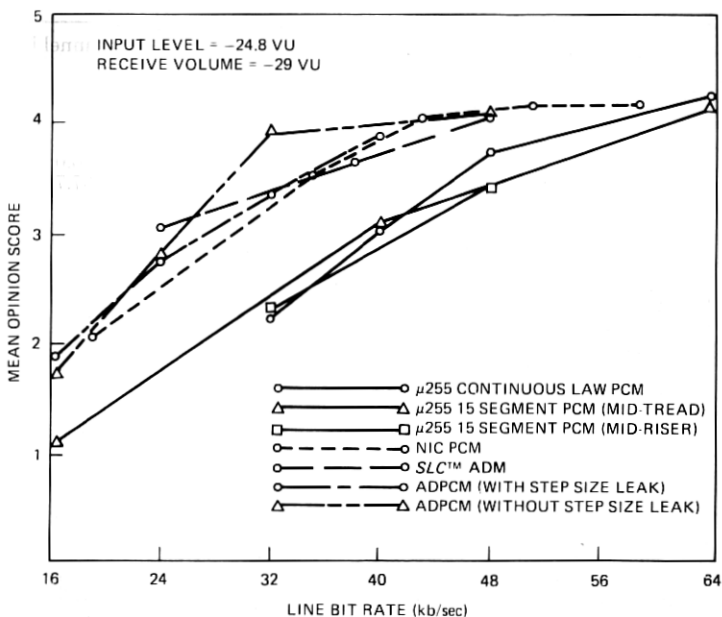

Fig. 8—Subjective results—single encodings vs line bit rate.

channel noises of the higher bit rate codec conditions listed in Table III are in the range of 13.3 to 26.3 dBrnC. The 4.2-dB loss following the decoders translates this range into 9.1 to 22.1 dBrnC at the line terminals of the telephone set. As these tests were conducted in an acoustically shielded room, the noise results of Fig. 7 show that subjects can react to



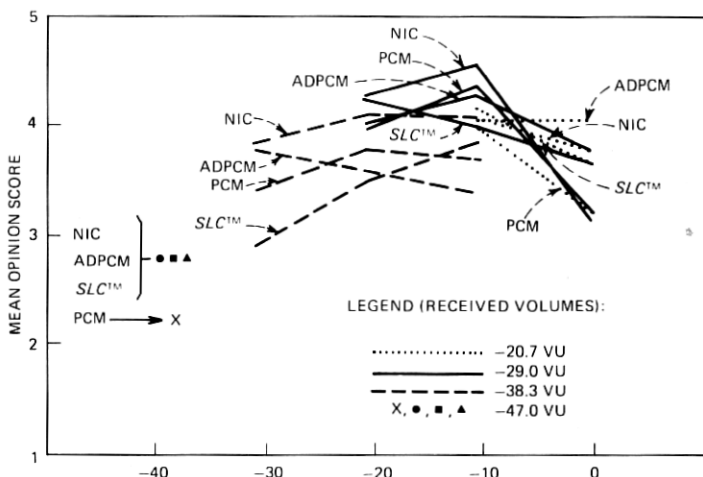

Fig. 9—Subjective results—variation of input level and receive volume.

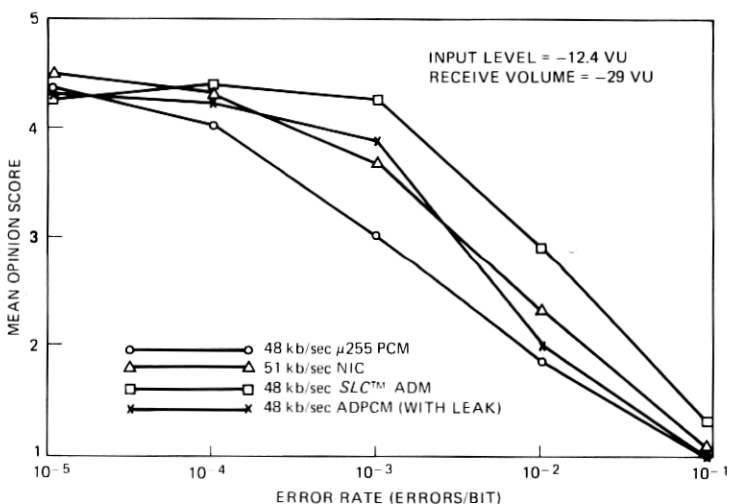

Fig. 10—Subjective results—line error rates.

noise levels on the order of 10 dB<sub>r</sub>nC, since the curves do not level off in this vicinity. Thus, the leveling-off tendency in Fig. 8 is in line with the noise response curves of Fig. 7 for the lower values of noise. A second factor may be the distortion and bandlimiting introduced by the transmitting and receiving 500-type telephone set pair.

Two other important observations can be extracted from Fig. 8. The first is that there appears to be no appreciable differences among the three versions of  $\mu$ 255 PCM tested, at least for bit rates greater than 32 kb/s. The other observation is that the introduction of step-size leak in the ADPCM algorithm (see Section 2.3) has a small effect on subjective

quality in the vicinity of 32 kb/s under these conditions. The intent here is not to determine the optimal amount of leak to be introduced but to demonstrate that leak can affect subjective quality.

The results for the subjective ratings as a function of input level and received volume are shown in Fig. 9. The results are grouped according to a fixed received volume with a varying input level. The solid lines represent the preferred received volume of  $-29$  VU with the dotted and dashed lines representing received volumes of  $-20.7$  VU and  $-38.3$  VU, respectively. The cluster of four points on the left-hand side of Fig. 9 represents the  $-47.0$  VU received volume where only one corresponding input level of  $-41.2$  VU is used. Each curve is a response for a particular codec and is labeled accordingly.

The MOS results in Fig. 9 are due to a combination of effects: (i) quantizing distortion, (ii) the received volume level that the subject hears at the telephone set, (iii) the absolute level of idle channel noise at the set terminals which is a function of both the input level and receive volume, and (iv) overload distortion which is manifested as amplitude-limiting for PCM and NIC and slope overload for the ADPCM and SLC ADM codecs. All four of these effects must be considered collectively when interpreting these plots. With these caveats in mind, a few observations can be made here with detailed analyses left to future studies.

The NIC algorithm is rated significantly better than the PCM algorithm for nearly all input levels and received volumes. This is an expected result, since the NIC codec readjusts its dynamic range for each block of eight samples. The amplitude overload point of both the PCM and NIC codecs for the speech sources in this study occurs at an input level of approximately  $-12.4$  VU. Thus, the subjective ratings of PCM and NIC are the greatest for the input level of  $-10.5$  VU, where only a small number of samples are clipped and the entire dynamic range is fully exercised. At the input level of  $-0.2$  VU, the peaks of the speech are roughly 12 dB above overload and the MOS ratings fall off for PCM and NIC at both received volumes of  $-20.7$  and  $-29$  VU.

The SLC ADM and ADPCM codecs hold up somewhat better for high input levels of speech, confirming that slope overload is "more" tolerable than amplitude overload. The ADPCM and SLC ADM codecs are rated comparably for the input levels of  $-10.5$  and  $-20.7$  VU.

Two additional general observations can be inferred from Fig. 9. First, the set of curves for the received volume of  $-29$  VU tends to have higher MOS ratings than the sets for received volumes of  $-20.7$  and  $-38.3$  VU. This can be attributed to three causes: (i)  $-29$  VU is the preferred received volume, (ii) the dynamic ranges of the PCM and NIC codecs are exercised fully with essentially no overloading, and (iii) the idle channel noises heard by the subjects are low because of the high input levels (0 to 4 dB<sub>BrnC</sub> for the input level of  $-10.5$  VU). These effects lead to higher MOS values than those shown for the same codecs in Fig. 8. The

second observation from Fig. 9 is that for the lowest received volume tested,  $-47.0$  vU, the adaptive codecs are scored equivalently with PCM receiving an even lower rating due to its coarse quantization of the speech at the input level of  $-41.2$  vU.

The final portion of the single encoding testing is concerned with the effect of line error rates on the four codecs in Table IIC. The results are tabulated in Table VII and shown in Fig. 10, where MOS is plotted versus the errors per bit on a logarithmic scale. Note that the response curves converge at low ( $10^{-5}$ ) and high ( $10^{-1}$ ) error rates. The  $10^{-1}$  rate is sufficiently severe so that the four codecs are all rated "unsatisfactory" and the  $10^{-5}$  error rate is virtually undetectable, and the four codecs are rated "good." The leveling-off of the four curves for low error rates at MOS values of 4.2 to 4.5 is slightly higher than the asymptotic value in Fig. 8. This is due to the fact that the input level of  $-12.4$  vU and the corresponding receive value of  $-29$  vU result in lower idle circuit noises as measured at the line terminals of the telephone set.

Significant differences among the codecs are only manifested in the area between  $10^{-4}$  and  $10^{-2}$  errors per bit. The *SLC* codec is the least sensitive to line errors while PCM is the most sensitive. NIC and ADPCM (with step-size leak) are rated nearly the same and fall between the *SLC* ADM and PCM extremes. Although the ADPCM codec without step-size leak was not formally tested in the presence of errors, informal listening tests have shown that it is subjectively comparable to the PCM codec.

## VI. SUBJECTIVE TESTING—TANDEM ENCODINGS

### 6.1 Test design

This section contains a description of the tandem encoding conditions listed in Table IV. Basically, the four codec algorithms of the previous section are used here at a few selected bit rates, again because of the constraint of economizing on the total number of test conditions. Evidence from the single encoding versus line bit rate tests show that the adaptive codecs, NIC, ADPCM, and *SLC* ADM have a 12- to 16-kb/s advantage over  $\mu 255$  PCM for bit rates below 48 kb/s. Thus, it was decided to compare 48-kb/s  $\mu 255$  PCM against NIC, ADPCM, and *SLC* ADM in the vicinity of 32 kb/s. The 8-kHz sampling rate dictated that ADPCM and NIC operate at 32 and 35 kb/s, respectively. Since the *SLC-40* ADM algorithm is implemented in the loop plant today, the sampling rate of that system, 37.7 kb/s, is used. Finally, there is interest in the tandem performance of D channel banks, hence 64-kb/s  $\mu 255$  PCM is included as a reference. ADPCM is implemented without step-size leak since subjects did perceive some degradation for ADPCM with leak at 32 kb/s.

The input speech level to the codecs is  $-20$  vU, approximately the speech volume averaged over Bell System local and toll connections.<sup>10</sup> The received volume is set at the preferred level of  $-29$  vU. A tabulation of the tandem encoding conditions is given in Table IV.

Table IV—Tandem encoding conditions

Codec	Bit Rate (kb/s)	Number of Tandem Encodings
PCM	64	1,2,4,6,8
PCM	48	1,2,4,8
NIC PCM	35	1,2,4,8
ADPCM	32	1,2,4,8
<i>SLC</i> <sup>TM</sup> ADM	37.7	1,2,4,8

To explain the tandem encoding process in more detail, two configurations are shown in Fig. 11 which are simply expansions of Fig. 2. The upper arrangement is applicable to the 8-kHz codecs, PCM, NIC, and ADPCM. The filtering used for bandlimiting and reconstruction is realized with transmit and receive filters with characteristics that are similar to those used in D3 channel banks.<sup>12</sup> Note that each time the tandem encoding loop is transversed, the filters encountered are a receive/transmit pair, analogous to a back-to-back D channel bank situation.

Tandem encodings of the 37.7-kb/s *SLC*-40 ADM are generated in a slightly different manner, as shown in the lower portion of Fig. 11. Specifically, the differences are manifested in the filtering. The *SLC* input and output filters, which are implemented in software, in conjunction with a 6.4-kHz low-pass filter provide sufficient rejection at half the 37.7-kHz sampling rate to avoid aliasing. After the desired number of tandem encodings have been simulated, a D channel bank transmit filter is inserted in the playback path prior to recording so that small bandwidth differences between the 8-kHz and 37.7-kHz *SLC* ADM conditions are eliminated.

The use of these two filtering strategies results in different in-band characteristics as illustrated in Figs. 12 and 13, where the overall responses for a single encoding and eight tandem encodings are given for the 8-kHz and the 37.7-kHz *SLC* ADM codecs, respectively.

## 6.2 Results and observations

The tandem encoding MOS results and the breakdown according to comment category are tabulated in Table VIII of the appendix.

These results are shown in Fig. 14, where the MOS ratings are plotted as a function of the number of tandem encodings. An immediate observation is the superiority of the 64-kb/s  $\mu$ 255 PCM over the other four codecs. This superiority is evidenced by the facts that the response curve for 64-kb/s PCM begins to fall off at four encodings while the responses for the other four codecs fall off at two encodings, and eight encodings of 64-kb/s PCM is rated slightly below a MOS of 4 ("good"), while eight encodings of the other codecs are rated between 3 ("fair") and 2 ("poor"). Even for eight encodings of 64-kb/s  $\mu$ 255 PCM, the degradation is not

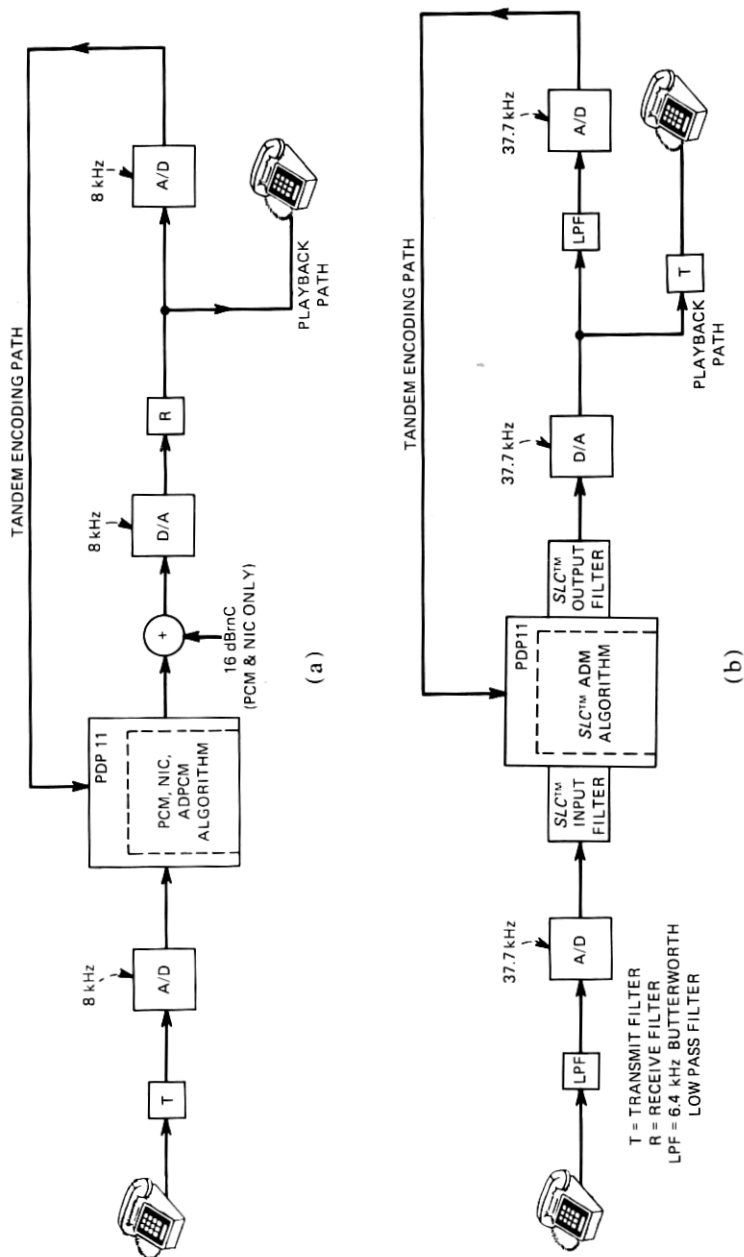

Fig. 11—Similar tandem encoding configuration. (a) PCM, NIC, and ADPCM configuration. (b) *SLC* ADM configuration.

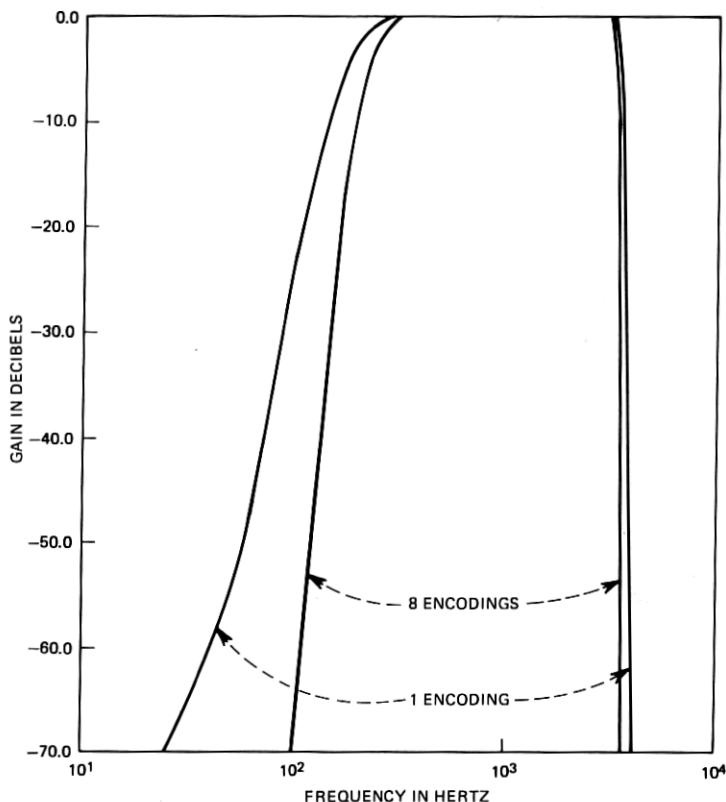

Fig. 12—Overall frequency response—8 kHz—one and eight encodings.

attributable only to quantizing noise. Accumulation of the idle channel noise and bandwidth reduction of the tandem filtering are other factors.

Another general observation is that, to a rough approximation, the three adaptive codecs (35-kb/s NIC, 32-kb/s ADPCM, and 37.7-kb/s *SLC* ADM) behave in a similar fashion to 48-kb/s PCM. This result concurs with the single encoding results of Fig. 8 where it was shown that the adaptive codecs exhibited a 12- to 16-kb/s subjective advantage over PCM.

Finally, all the curves in Fig. 14 at one encoding agree well with the single encoding results of Fig. 8 after it is recognized that the input level here is 4.8 dB greater than that of the single encoding tests. Both the single encoding versus line bit rate and tandem encoding tests were conducted at the received volume of -29 VU. Thus, the higher input level in the tandem encoding tests results in a 4.8-dB reduction in the idle channel noises heard by the subjects.

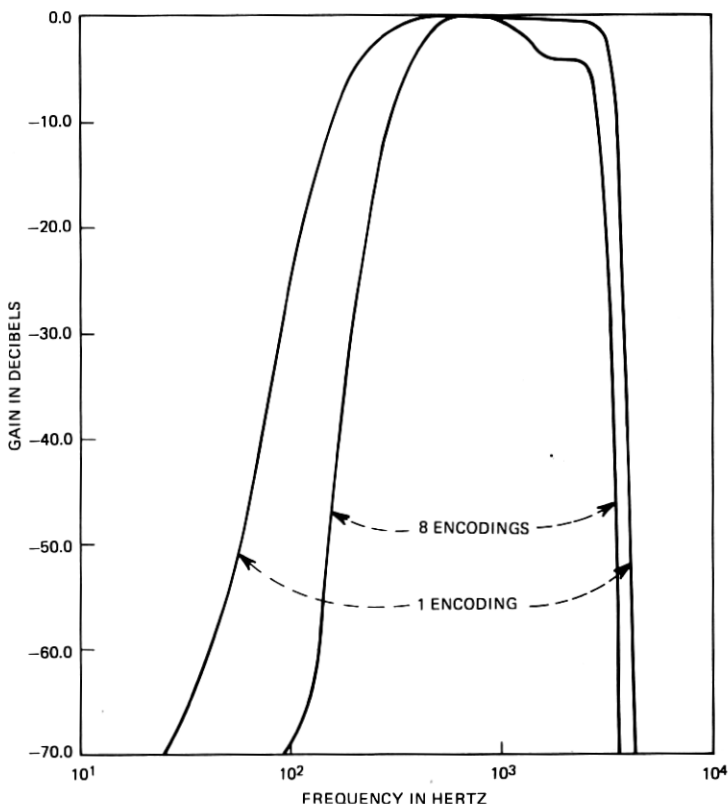

Fig. 13—Overall frequency response—37.7 kHz—one and eight encodings.

## VII. SUBJECTIVE TESTING—REFERENCE CONNECTIONS

The purpose of the reference connection conditions is to evaluate the codecs of the previous section in representative network connections. Basically, these reference connections are of three types: local, exchange, and toll. The codecs are placed in connections where the environment in terms of speech volume, analog loss, and analog noise is defined from survey data. The received volumes are not held constant, but vary depending on the loss in the connection. For all connections, the codec characteristics such as overload and idle channel noise are defined in Section II. The connections are chosen in such a manner that average and worst-case situations are represented.

Many reference connections involve similar and dissimilar tandem encodings. Prior to a detailed description of the different connections, a few words on the analog interface between successive encodings are appropriate. The four codecs can be grouped into two categories determined by whether the sampling rate is 8 kHz or 37.7 kHz. This leads to four possible combinations in simulating a tandem encoding because

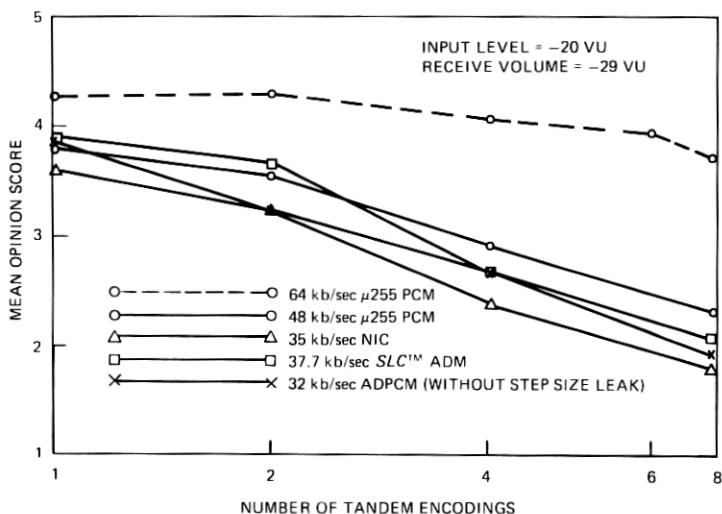

Fig. 14—Subjective results—tandem encodings.

of the filtering that is necessary. These four configurations are shown in Fig. 15. The top and bottom are identical to those shown in Fig. 11 since the sampling rates of the two codecs are the same. The two center arrangements in Fig. 15 are the cases where an 8-kHz and 37.7-kHz codec are both involved. Here the D channel bank transmit and receive filters are utilized with the SLC input and output filters. These four arrangements apply to the remainder of the discussions on reference connections.

## 7.1 Test design

### 7.1.1 Local reference connections

The local connection conditions are configured as shown in Fig. 16. There are four types of connections, depending on the presence of codecs in the loops: (i) near- and far-end loops, both analog, (ii) codec in near-end loop, (iii) codec in far-end loop, and (iv) codec in both loops. Note that an average loop loss of 3.7 dB<sup>13</sup> is assumed regardless of the presence or absence of a codec. It is recognized that this assumption may be inappropriate when a codec is present, since the loop loss might be reduced. However, this loss is fixed to avoid confounding the subjective effect of loss variation with that of introducing a codec in the loop. The input speech volume is chosen to be the average found for local calls, -24.8 VU.<sup>10</sup> The assumed loop loss of 3.7 dB translates this into a received volume of about -28.5 VU.

The central office is modeled as either an analog switch or a 64-kb/s  $\mu$ 255 PCM digital switch. When the office is analog, 16 dBnC of random noise is added to the speech as it traverses the office. This noise value



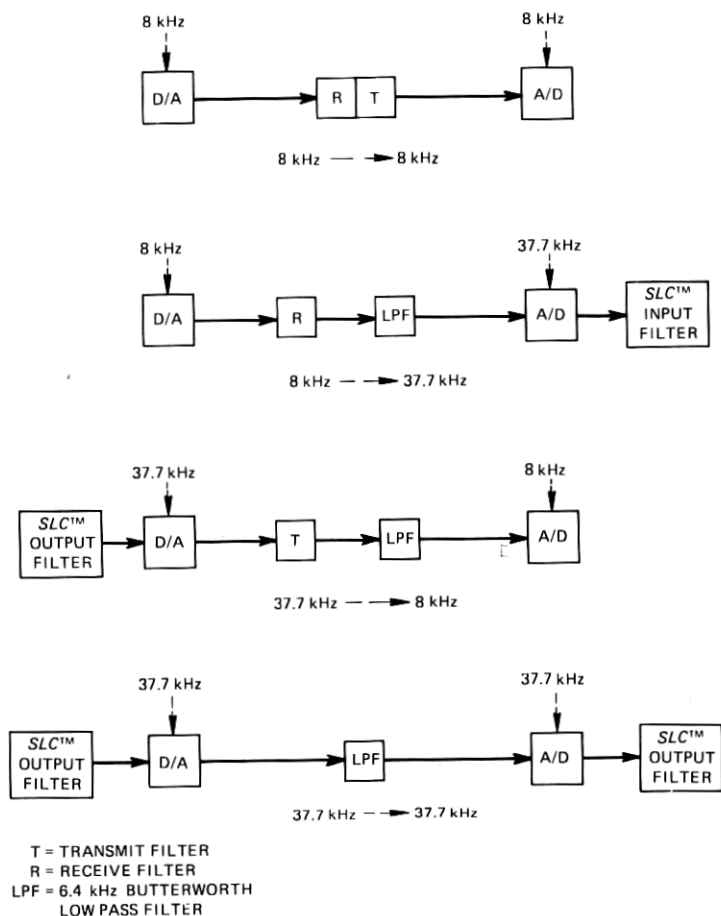
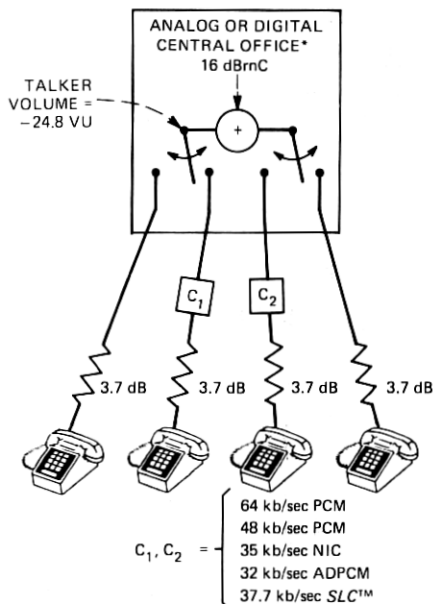

Fig. 15—Dissimilar tandem encoding configuration.

is chosen to correspond to the digital switch where 16 dB<sub>BrnC</sub> is added after the PCM decoder, as described in Section 2.1. In the context of this local environment, the local reference connection conditions to be subjectively evaluated are listed in Fig. 21. In the conditions with a codec in both loops, the two codecs may be either identical or dissimilar. For the case of two dissimilar codecs, the subjective effect of ordering is investigated by including conditions where the physical locations of the codecs are interchanged.

### 7.1.2 Exchange reference connections

The exchange reference connection model is shown in Fig. 17. This model is a simple extension of the local connection model in that an additional central office is connected to the first office via a direct trunk. The central offices and loops, whether analog or digital, are modeled as in the local reference connections.



\*64 kb/sec  $\mu$ 255 PCM DIGITAL CENTRAL OFFICE

Fig. 16—Local reference connections.

The direct trunk facility between the central offices is either analog or digital. The loss used in both cases is 3 dB. In addition, 14.8 dBnC of noise derived from survey data is introduced on the analog trunk. On the digital direct trunk, the noise introduced is the characteristic idle channel noise of the codec. The speech volume in both situations is  $-23.1$  VU,<sup>10</sup> slightly higher than that found on the local reference connections.

To keep the number of conditions down to a manageable level, codecs are introduced into the exchange connection in only one manner. If a codec is to appear in the connection, it must appear in all three components of connection simultaneously—both loops and the direct trunk. Furthermore, the three codecs must be identical; a mixture of different codecs is not allowed. Using these rules, the exchange reference connection conditions are formulated and tabulated in Fig. 22.

When both central offices are digital (64-kb/s  $\mu$ 255 PCM) and the codecs in the loops and direct trunk are either PCM or NIC, only a trivial code conversion is needed between the office and loop or trunk. The 3-dB direct trunk loss can be included in the far-end loop loss, and the entire connection collapses into a single encoding. For the case of the three ADPCM codecs, the analog link between the codec and digital central office can also be eliminated. All that is necessary is an intermediate D/D conversion to uniform PCM. Thus, the entire connection is digital where the 3-dB loss is a digital loss and is introduced where it is depicted in Fig. 17.

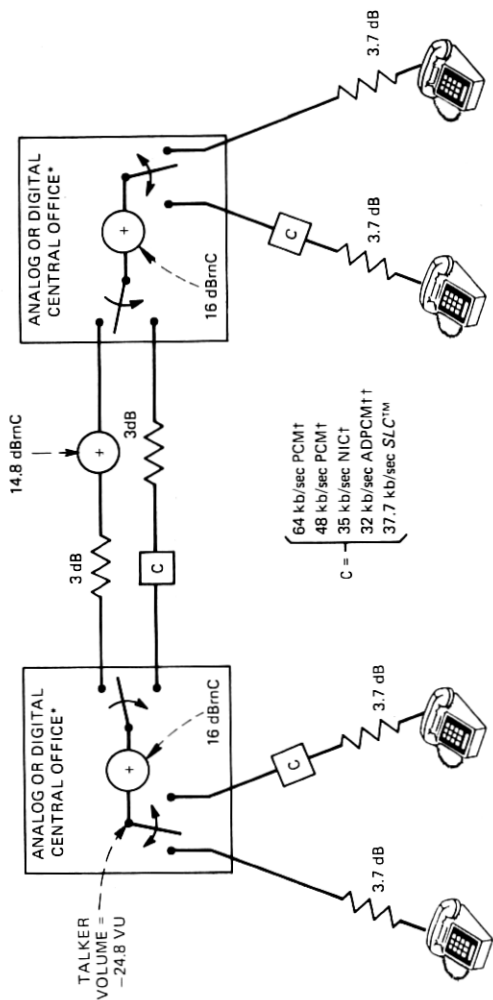

\*64 kb/sec  $\mu$ 255 PCM DIGITAL CENTRAL OFFICE  
†FOR DIGITAL CENTRAL OFFICE, CONNECTION  
COLLAPSES INTO A SINGLE ENCODING FOR  
THESE CODECS

††FOR DIGITAL CENTRAL OFFICE, ADPCM AND  
PCM ENCODINGS ARE SYNCHRONOUS WITH  
RESPECT TO EACH OTHER

Fig. 17—Exchange reference connections.

### 7.1.3 Toll reference connections

The toll reference connections are arrived at using the diagram in Fig. 18. Essentially, this diagram differs from Fig. 17 in that the direct trunks are replaced with the toll network wherein a connection comprises two toll-connecting trunks and one or more intertoll trunks. The toll network is assumed to be implemented on analog and digital facilities where "digital" implies only 64-kb/s  $\mu$ 255 PCM-No. 4 ESS switches, VIF terminals, and D channel banks.<sup>1</sup> The codecs described in the previous two sections will only be modeled in loops on the ends of the toll connection. Thus, a toll reference connection consists of two loops where a codec may appear and toll trunks with various mixtures of analog and digital 64-kb/s  $\mu$ 255 PCM facilities.

The local portion of Fig. 18 is similar to that in the local and exchange reference connections with the following exceptions. To limit the total number of test conditions, only the analog version of the central office is configured in toll connections. As before, a 16-dBrnC noise source is

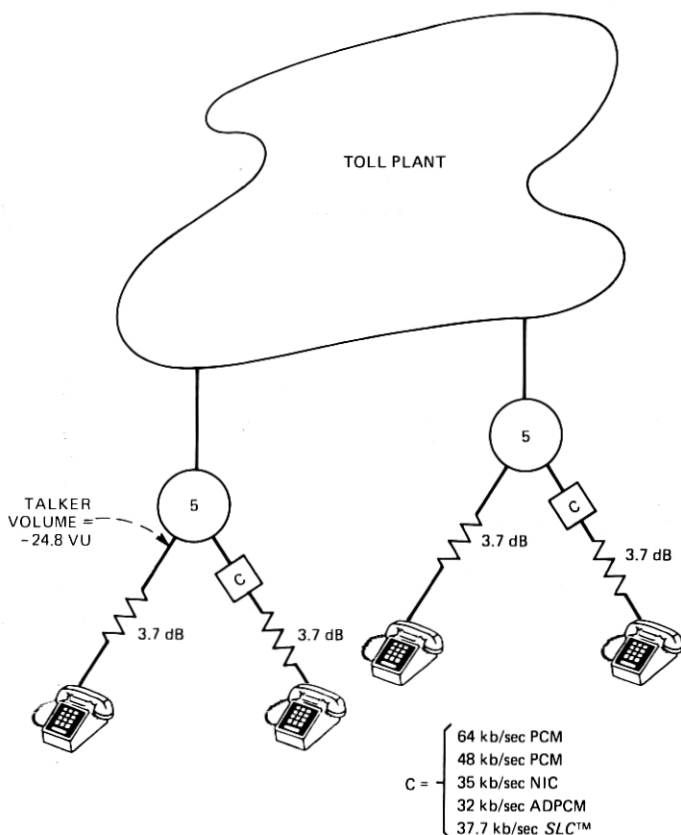

Fig. 18—Toll connection diagram.

incorporated in the central office model. The average speech volume used in the toll reference connections is significantly higher than that found in local and exchange connections and was found by McAdoo to be  $-16.8$  vU.<sup>10</sup> Finally, when two codecs are simultaneously introduced in both loops on a particular connection, both codecs are always identical.

Four types of toll connections are considered here: (i) short, (ii) long, (iii) "worst-case" long, and (iv) all-digital. The short and long toll connections are further divided into three subcategories according to facility makeup: (a) analog switches and analog transmission facilities, (b) analog switches and digital transmission facilities, and (c) digital switches and analog transmission facilities. The "worst-case" long connection is simply derived from the long toll connection by the introduction of additional intertoll trunks. The all-digital connection consists of a single 64-kb/s  $\mu$ 255 PCM encoding in the toll network with the speech in digital form between the transmit and receive central offices.

The toll reference connections are now described, using Fig. 19.

(i) *Short Toll Connections*—The analog connection  $S_1$  consists of two toll connecting trunks and a single short intertoll trunk. The toll connecting trunks are characterized by a VNL loss of 3 dB and an average survey noise source of 11.3 dBrnC.<sup>14</sup> The 60-mile intertoll trunk has a VNL design loss of 0.5 dB and a projected noise of 20.4 dBrnC.<sup>11</sup> The analog toll switches are assumed to add noise in an amount equivalent to 12 dBrnC. These characterizations of analog transmission and switching facilities will apply to all the toll connections discussed from this point on.

The center configuration,  $S_2$ , is a modification of  $S_1$  where the analog toll switches are replaced with No. 4 ESS switches and VIF terminals. The VIF terminal involves a 64-kb/s  $\mu$ 255 PCM encoding and decoding followed by a 16-dBrnC0 noise source as described in Section 2.1. This translates into 13 dBrnC at the  $-3$  TLP point for the speech with the codec overload set at  $+3$  dBm0.

The bottom configuration,  $S_3$ , is another modification of  $S_1$  with digital transmission facilities and analog switches. All three trunks are analog trunks, and VNL loss design applies. However, the noise sources on the toll-connecting and intertoll trunks have been replaced with the appropriate idle channel noises at the decoder side of the D channel banks.

(ii) *Long Toll Connections*—Referring to configuration  $L_1$  in the diagram, the toll-connecting portion is identical to that of the short connection. The intertoll section consists of two intertoll trunks, a short (48 mi.) and a long (1300 mi.) one. The short trunk has loss and noise characteristics similar to the intertoll trunk in the short connection described above. Using VNL design and survey data, the long intertoll trunk has a loss of 2.0 dB and a noise of 37.8 dBrnC.

S<sub>1</sub> — ALL ANALOG

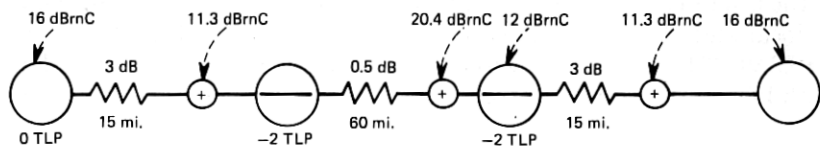

S<sub>2</sub> — DIGITAL SWITCHES + ANALOG TRANSMISSION

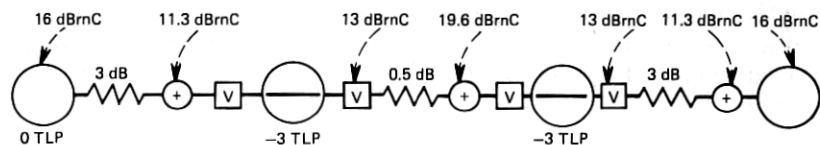

S<sub>3</sub> — ANALOG SWITCHES + DIGITAL TRANSMISSION

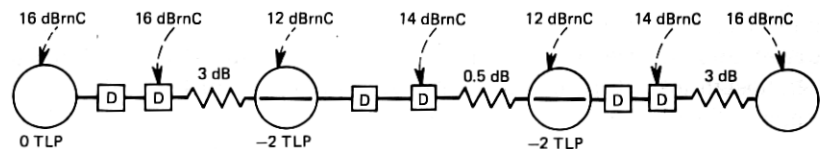

V = VOICEBAND INTERFACE FRAME  
D = D CHANNEL BANK

Fig. 19—Toll reference connections. (a) Short toll connections. (Figs 19b and 19c on following pages.)

Configuration L<sub>1</sub> is modified in a manner identical to that described above for the short toll connection to produce the mixed analog and digital connections, L<sub>2</sub>, and L<sub>3</sub>. Of significant interest here is the reduction of noise with the deployment of digital transmission facilities in configuration L<sub>3</sub>. It is expected that this reduction in noise will manifest itself subjectively.

(iii) *Worst-Case Long Toll Connection*—This condition is dubbed “worst case” for two reasons. First, it is constructed from L<sub>2</sub> of the long toll connections by the addition of three intertoll trunks for a total of five intertoll trunks. Network statistics show that a small percentage of toll connections are made over five intertoll trunks. Second, the No. 4 ESS with analog transmission facilities type of connection contains not only all the analog impairments such as loss and noise but also the 64-kb/s  $\mu$ 255 PCM encodings. In this connection, there are a total of six PCM encodings in the toll portion and also codecs in the loops.

(iv) *All-Digital Toll Connection*—This connection is the simplest

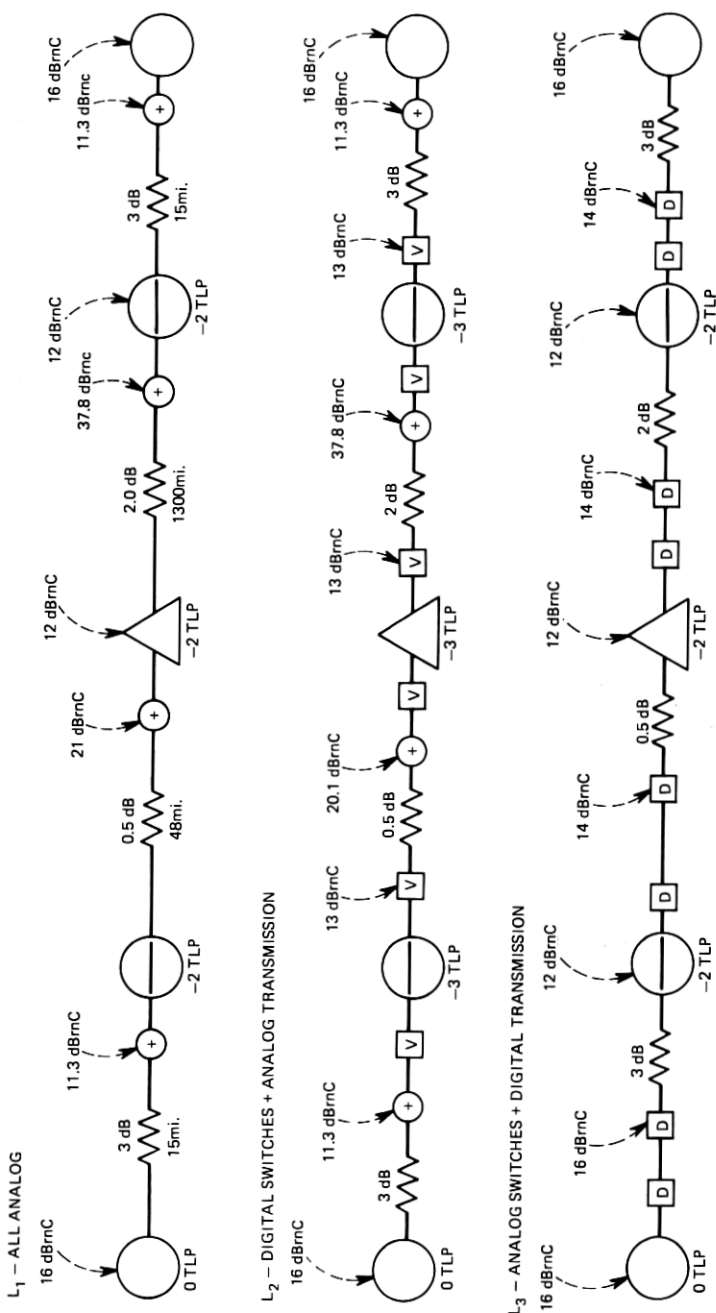

Fig. 19(b)—Long toll connections.

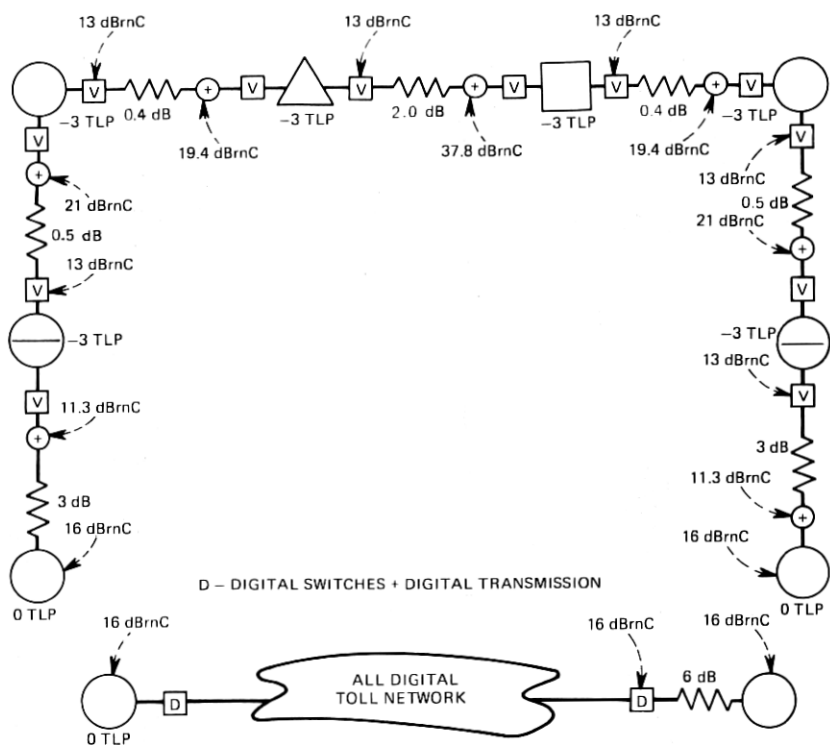

Fig. 19(c)—Worst-case and all-digit toll connections.

of the toll connections in that the toll network (switches and trunks) is purely digital. Hence, the toll network can be modeled by a single 64-kb/s  $\mu$ 255 PCM encoding implemented on a D channel bank on each toll-connecting trunk and a fixed 6-dB loss at the receiving central office.

The  $\mu$ 255 PCM at 48 and 64 kb/s, 35-kb/s NIC, 32-kb/s ADPCM, and 37.7-kb/s SLC ADM codecs are incorporated in the loops on the eight toll connections described above.

## 7.2 Results and observations

Detailed tabulations of the MOS ratings for the local, exchange, and toll reference connection conditions are given in Tables IX through XII in the appendix. A cumulative comparison of the analog noise ratings is plotted in Fig. 20, where the single encoding noise results are plotted along with the tandem encoding and reference connection results to illustrate a comparison across all the blocks of testing.



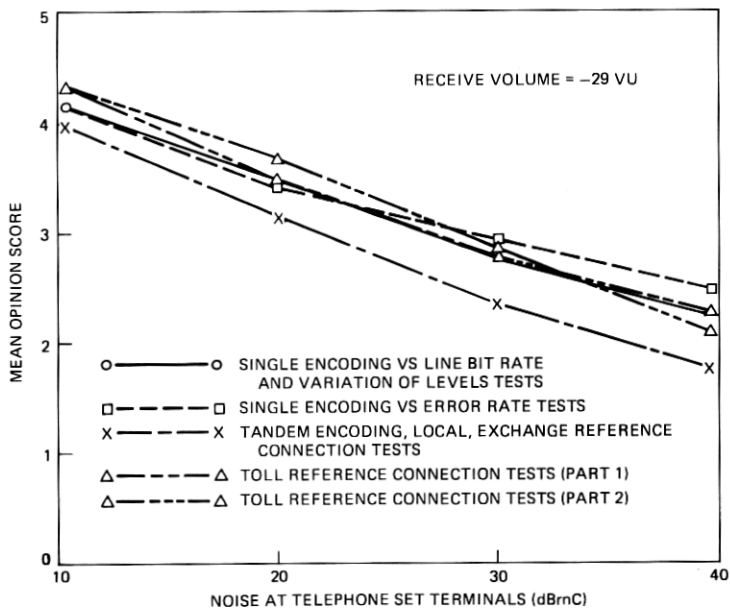

Fig. 20—Subjective results—additive random noise.

### 7.2.1 Local reference connections

The local reference connection results are summarized in Fig. 21. In this figure, the connections of Fig. 16 are redrawn to aid the reader in associating the connection with the results. The top configuration of Fig. 21 is the analog version of the connection where the only impairment introduced in the speech is the noise of the analog central office. This amounts to 12.3 dBmC of noise with a speech level of -28.5 VU at the telephone set terminals. This condition is rated with a MOS of 4.0 and is in agreement with the noise results shown in Fig. 20.

The second configuration represents the digital central office case using 64-kb/s  $\mu$ 255 PCM. As described in Section 2.1, 16 dBmC of noise is introduced into the speech following the decoder so that the speech level and idle channel noise at the line terminals of the telephone set are identical to those of the analog connection above it. The MOS of this connection is 4.0 and it is concluded that the 64-kb/s PCM office introduces no additional subjective distortion.

The bottom configuration in Fig. 21 is used to represent all possible combinations of codecs in the loops. The table directly beneath it gives the MOS ratings for three cases: (i) codec in the transmit loop with an analog receive loop, (ii) codec in the receive loop with an analog transmit loop, and (iii) codecs in both loops. The first two columns are essentially single encodings with the addition of the 16-dBmC office noise. These results are in agreement with the single encoding results of Section 5.2.

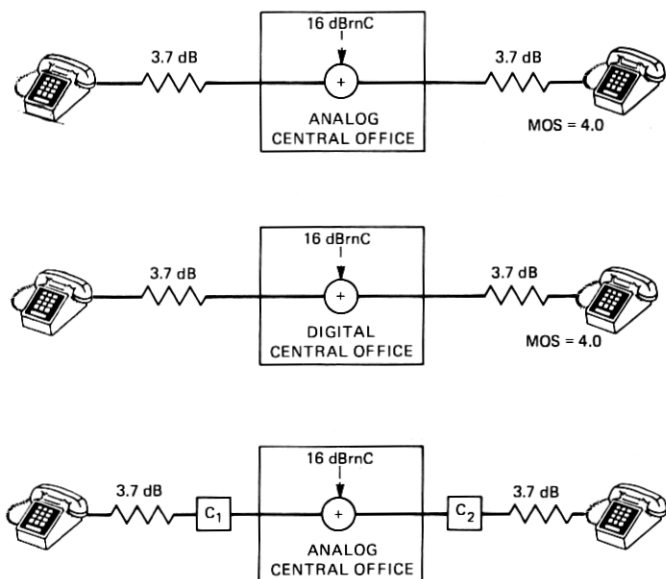

CODEC		MEAN OPINION SCORES		
		C <sub>1</sub> ONLY	C <sub>2</sub> ONLY	C <sub>1</sub> AND C <sub>2</sub>
64 kb/sec	PCM	3.7	3.8	3.8
48 kb/sec	PCM	3.4	3.5	3.3
35 kb/sec	NIC	3.3	3.3	3.0
32 kb/sec	ADPCM	3.6	3.5	3.2
37.7 kb/sec	SLC™	3.6	3.6	3.2

C <sub>2</sub>		64 kb/sec PCM	48 kb/sec PCM	35 kb/sec NIC	32 kb/sec ADPCM	37.7 kb/sec SLC™
64 kb/sec	PCM		3.4	3.1	3.3	3.6
48 kb/sec	PCM	3.5		3.0	3.0	3.2
35 kb/sec	NIC	3.2	2.9		3.1	3.2
32 kb/sec	ADPCM	3.4	3.2	2.9		3.3
37.7 kb/sec	SLC™	3.5	2.8	3.1	3.1	

Fig. 21—Subjective results—local reference connections.

The third column represents two codecs in tandem with the addition of the office noise. It is observed that a second 64-kb/s  $\mu$ 255 PCM encoding does not introduce any additional degradation, while the MOS ratings for the other four codecs are slightly lower than those for the case of a single codec in one loop of the connection. This result is in agreement with the tandem encoding results discussed in Section 6.2.

The bottom table in Fig. 21 is a matrix of the results for mixed tandem encodings, that is, there are codecs in both loops but they are dissimilar. Reversal of the ordering of any pair of codecs is indicated by interchanging the row and column indices for any element in the matrix. A comparison of the elements in the upper and lower triangular portions

of the matrix leads to the following conclusions: (i) the subjective performance of a tandem encoding involving 64-kb/s PCM and one of the four lower bit rate codecs is roughly equivalent to a single encoding of the lower bit rate codec, and (ii) the subjective effects of ordering in dissimilar tandem encodings are small for the five codecs discussed here.

### 7.2.2 Exchange reference connections

The exchange reference connection results are shown in Fig. 22. In keeping with the format of the local reference connections, the top configuration in Fig. 22 represents the all-analog exchange connection. Here, 19.5 dBrnC of noise appears with the  $-29.8$  VU speech at the telephone set terminals and is rated with a MOS of 3.6 by the subjects.

The second connection in Fig. 22 is identical to the analog connection except that three identical codecs are introduced in the exchange trunk and both loops. Note that the 14.8-dBrnC noise on the analog exchange trunk is effectively replaced by the idle channel noise of the codec. The table immediately below this connection lists the MOS results for the five codecs. The introduction of the three 64-kb/s PCM codecs does not alter the MOS rating over that of the analog connection. However, three encodings of one of the other four codecs degrades the connection somewhat.

The last configuration in Fig. 22 is a modification of the second configuration which is realized by replacing both analog central offices with digital central offices. As explained in Section 7.1, the resulting connection can be represented as either a single encoding, a series of synchronous tandem encodings with intermediate D/D conversions, or a series of asynchronous encodings with intermediate analog links, depending on code compatibility between the 64-kb/s PCM central offices and the codecs on the loops and exchange trunk. For 64-kb/s PCM, 48-kb/s PCM, and 35-kb/s NIC, the connection from the encoder of the transmit codec to the decoder of the receive codec collapses into a single encoding. The 3-dB exchange trunk loss is incorporated in the loop loss following the decoder. Thus, the first three entries in the table under this connection represent single encodings of these codecs. Consequently, the reduction of noise over the all-analog connection results in MOS ratings higher than the analog connection rating of 3.6. In the case of ADPCM, the successive encodings are performed synchronously with a corresponding reduction in noise, and the connection is rated nearly equivalent to the analog connection. The final entry for the *SLC* ADM codec is virtually identical to the analog central office case because all the noise sources are unchanged and the tandem encodings are performed asynchronously with the analog central offices replaced by 64-kb/s PCM digital central offices.

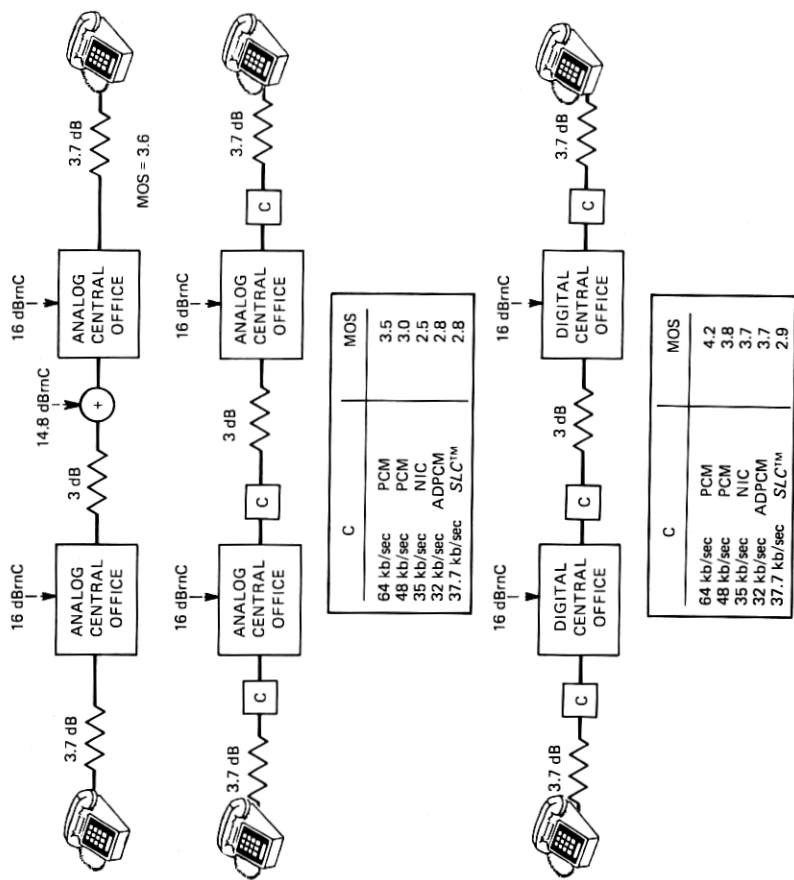

Fig. 22—Subjective results—exchange reference connections.

### 7.2.3 Toll reference connections

The final portion of the subjective testing is concerned with the effects of codecs in toll reference connections. The codecs are placed in loops on the ends of the eight toll connections of Fig. 19. This is accomplished in two steps. The first step is the placing of a codec in the receive loop only and, in the second step, identical codecs are placed in both loops.

Figure 23 displays the results for a codec in the receive loop only. The results for the longer toll connections on which 37.8-dBrnC of noise appears demonstrate that the noise is the dominant impairment and the effects of the codecs are of little importance (see connections  $L_1$ ,  $L_2$ , and  $W$ ). The MOS ratings of these connections are tightly grouped in the area of a MOS of 3 ("fair"), indicating that the subjects are reacting only to the noise source. Note that the noises on the intertoll trunks translate to approximately 31 dBrnC of noise at the line terminals of the telephone set for these three connections. A check with the noise results of Fig. 20 indicates agreement. It is also observed that in toll connection  $L_3$ , the 37.8-dBrnC noise is eliminated because of the deployment of digital transmission systems on the intertoll trunks. This shifts the MOS ratings upward in line with those obtained for the short ( $S_1$ ,  $S_2$ ,  $S_3$ ) and all-digital ( $D$ ) connections.

The toll connections which received the higher subjective scores ( $S_1$ ,  $S_2$ ,  $S_3$ ,  $L_3$ , and  $D$ ) show that, if the quality of the connection is good, subjects can discriminate among the five codecs and the MOS ratings are spread out over a point or so. However, it is observed that, even though the discrimination between one codec and the next may be small, on most connections the 64-kb/s PCM codec case is rated nearly equivalent to the case where both loops are analog. Also, a comparison of connections  $S_1$  versus  $S_2$  and  $L_1$  versus  $L_2$  with both loops analog serves to demonstrate that the addition of 64-kb/s PCM codecs in the analog toll portion of the connection does not significantly alter the subjective performance of the connection.

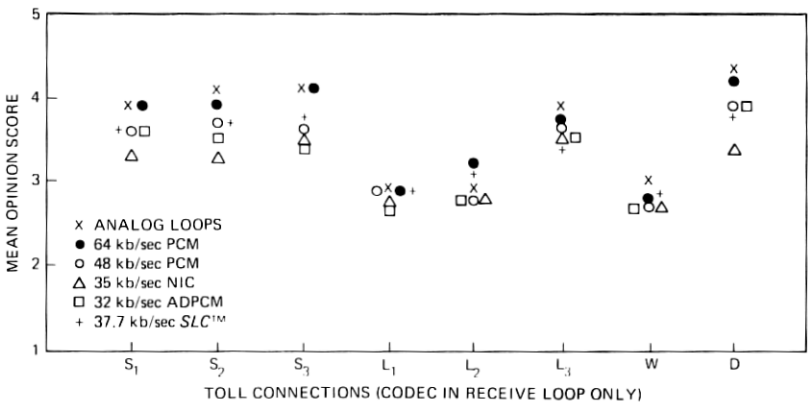

Fig. 23—Subjective results—toll reference connections.

The introduction of codecs in both loops of the toll connections results in the ratings of Fig. 24. Many of the observations for Fig. 23 apply here with minor modification. The toll connections of  $L_1$ ,  $L_2$ , and  $W$  are rated the same with codecs in both loops when compared to the results for a codec in the receive loop only. In nearly all of the connections, the 64-kb/s PCM and analog loop cases again receive nearly equivalent ratings. The only differences between the results of Figs. 23 and 24 are those for connections with the higher ratings ( $S_1$ ,  $S_2$ ,  $S_3$ ,  $L_3$ , and  $D$ ). Here the spread among the MOS results for the lower bit rate codecs has increased because codecs are introduced in both loops. This indicates that subjects can perceive an additional degradation for two encodings of the lower bit rate codecs over a single encoding, a result already demonstrated in the tandem encoding results of Section 6.2.

### VIII. CONCLUSIONS

Several important conclusions can be drawn from the results presented in this paper for speech:

(i) The 64-kb/s  $\mu$ 255 PCM codec can be used, with very few restrictions, in the telephone network without affecting speech performance. It can be tandemed up to eight times without introducing serious subjective degradation. It can be inserted in a variety of analog network connections with essentially no subjective penalty. However, it is shown that eight encodings of either 48-kb/s  $\mu$ 255 PCM, 35-kb/s NIC, 32-kb/s ADPCM, or 37.7-kb/s *SLC* ADM introduce significant subjective degradations.

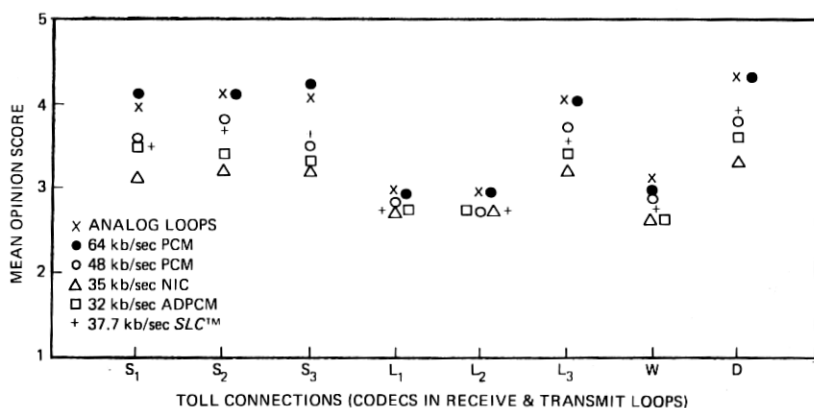

Fig. 24—Subjective results—toll reference connections.

This conclusion supports the general application of the 64-kb/s  $\mu$ 255 PCM in the combined analog and digital network which is likely to exist for many years to come. The use of codecs with lower bit rates would require more stringent application rules to avoid excessive degradation in tandem arrangements.

(ii) The  $10^{-6}$  error rate minor alarm level for the toll switched digital network,<sup>1</sup> which uses 64-kb/s  $\mu$ 255 PCM, is more than adequate for speech since the results of this study show that the subjective degradation at a  $10^{-5}$  error rate is negligible. In other words, if error rates could be guaranteed to never exceed  $10^{-6}$  errors/bit, then error rate would not be a consideration for the four 48-kb/s codecs tested.

(iii) Connection degradation is dominated by high levels of random noise that may be found on long toll connections. However, the 64-kb/s  $\mu$ 255 PCM all-digital toll connection shows that the network performance will improve as the network becomes increasingly digital. As the network evolves, the performance should not be unduly limited by the choice of codec deployed in the loops.

(iv) For single encodings, the results show that the three adaptive coding schemes (NIC, ADPCM, and *SLC* ADM) have about a 12- to 16-kb/s advantage over  $\mu$ 255 PCM for equivalent subjective ratings. This advantage can also be inferred from the tandem encoding and reference connection results where 48-kb/s PCM has approximately the same rating as 35-kb/s NIC, 32-kb/s ADPCM, and 37.7-kb/s *SLC* ADM.

(v) At 48-kb/s, the level variation and error rate tests demonstrate that the three adaptive codecs are slightly superior to PCM under these conditions.

(vi) For the three adaptive coding algorithms (NIC, ADPCM, and *SLC* ADM), no single algorithm is significantly superior to the other two on an overall basis. All three perform comparably, with small variations over the range of conditions tested.

## IX. ACKNOWLEDGMENTS

The authors wish to express their appreciation to a number of people at Bell Laboratories in Holmdel, N.J., who have made this study possible. W. C. Kublin, T. A. Pappas, and E. C. Stevens helped set up and conduct the subjective tests. P. C. Lopiparo contributed advice and moral support in constructing the simulation facility. Finally, discussions with J. E. Abate and J. L. Sullivan on the content of the tests are sincerely appreciated.

## APPENDIX

Table V—Detailed tabulation of subjective scoring for single encoding vs line bit rate tests

Codec	Bit Rate (kb/s)	Votes	% Exc	% Good	% Fair	% Poor	% Uns.	MOS	$\sigma$
PCM	32	102	0.0	1.0	31.4	54.9	12.8	2.2	0.66
PCM	40	102	2.0	20.6	56.9	18.6	2.0	3.0	0.74
PCM	48	102	15.7	47.1	32.4	4.9	0.0	3.7	0.78
PCM	64	101	35.6	49.5	14.9	0.0	0.0	4.2	0.68
PCM <sub>1</sub>	32	102	0.0	2.0	30.4	62.8	4.9	2.3	0.59
PCM <sub>1</sub>	48	101	4.0	43.6	42.6	9.9	0.0	3.4	0.72
PCM <sub>2</sub>	16	102	0.0	0.0	0.0	6.9	93.1	1.1	0.25
PCM <sub>2</sub>	40	101	3.0	25.7	48.5	22.8	0.0	3.1	0.77
PCM <sub>2</sub>	64	102	30.4	53.9	15.7	0.0	0.0	4.2	0.66
NIC	19	100	0.0	1.0	27.0	49.0	23.0	2.1	0.73
NIC	35	102	10.8	38.2	43.1	7.8	0.0	3.5	0.79
NIC	43	101	22.8	58.4	18.8	0.0	0.0	4.0	0.64
NIC	51	101	30.7	54.5	13.9	1.0	0.0	4.2	0.68
NIC	59	101	33.7	53.5	10.9	2.0	0.0	4.2	0.70
ADPCM	32	101	19.8	41.6	36.6	2.0	0.0	3.8	0.77
ADPCM	48	102	31.4	50.0	17.6	1.0	0.0	4.1	0.72
ADPCM <sub>1</sub>	16	101	0.0	0.0	12.9	61.4	25.7	1.9	0.61
ADPCM <sub>1</sub>	24	102	1.0	9.8	51.0	38.2	0.0	2.7	0.67
ADPCM <sub>1</sub>	32	102	3.9	37.3	51.0	6.7	1.0	3.4	0.71
ADPCM <sub>1</sub>	40	101	19.8	48.5	26.7	5.0	0.0	3.8	0.80
ADPCM <sub>1</sub>	48	102	30.4	55.9	12.8	1.0	0.0	4.2	0.67
SLC™	24	102	2.0	20.6	57.8	18.6	1.0	3.0	0.71
SLC	37.7	101	11.9	46.5	36.6	5.0	0.0	3.7	0.75
SLC	48	102	29.4	51.0	15.7	3.9	0.0	4.1	0.78
Noise 10 dB <sub>BrnC</sub>	203	34.0	47.3	17.2	1.5	0.0	4.1	0.74	
Noise 20 dB <sub>BrnC</sub>	204	9.8	30.9	51.5	7.8	0.0	3.4	0.77	
Noise 30 dB <sub>BrnC</sub>	203	1.5	15.3	46.8	35.0	1.5	2.8	0.76	
Noise 40 dB <sub>BrnC</sub>	203	1.5	3.5	26.6	54.2	14.3	2.2	0.79	
Q—5 dB	203	0.0	0.0	0.0	32.0	68.0	1.3	0.47	
Q—10 dB	204	0.0	0.5	18.1	54.4	27.0	1.9	0.68	
Q—15 dB	204	0.0	10.3	48.5	35.8	5.4	2.6	0.74	
Q—20 dB	203	2.0	32.0	53.2	12.8	0.0	3.2	0.69	
Q—25 dB	203	23.2	50.3	25.1	1.5	0.0	4.0	0.73	

### Notation:

PCM = 15-segment PCM (mid-tread)

PCM<sub>1</sub> = 15-segment PCM (mid-riser)

PCM<sub>2</sub> = continuous law PCM (mid-tread)

NIC = NIC PCM

ADPCM = ADPCM (without step-size leak)

ADPCM<sub>1</sub> = ADPCM (with step-size leak)



Table VI—Detailed tabulation of subjective scoring for single encoding vs level variation tests

Codec	Levels	Votes	% Exc.	% Good	% Fair	% Poor	% Uns.	MOS	$\sigma$
PCM	I <sub>1</sub> ,R <sub>1</sub>	51	5.9	31.4	41.2	19.6	2.0	3.2	0.89
PCM	I <sub>1</sub> ,R <sub>2</sub>	51	5.9	25.5	52.9	15.7	0.0	3.2	0.77
PCM	I <sub>2</sub> ,R <sub>1</sub>	51	33.3	37.3	19.6	9.8	0.0	3.9	0.96
PCM	I <sub>2</sub> ,R <sub>2</sub>	51	45.1	43.1	11.8	0.0	0.0	4.3	0.68
PCM	I <sub>2</sub> ,R <sub>3</sub>	51	13.7	43.1	39.2	3.9	0.0	3.7	0.76
PCM	I <sub>3</sub> ,R <sub>2</sub>	51	19.6	54.9	25.5	0.0	0.0	3.9	0.67
PCM	I <sub>3</sub> ,R <sub>3</sub>	51	17.7	43.1	37.3	2.0	0.0	3.8	0.76
PCM	I <sub>4</sub> ,R <sub>3</sub>	51	0.0	41.2	56.9	2.0	0.0	3.4	0.53
PCM	I <sub>5</sub> ,R <sub>4</sub>	51	0.0	2.0	31.4	52.9	13.7	2.2	0.69
NIC	I <sub>1</sub> ,R <sub>1</sub>	51	15.7	49.0	31.4	3.9	0.0	3.8	0.76
NIC	I <sub>1</sub> ,R <sub>2</sub>	51	5.9	25.5	47.1	21.6	0.0	3.2	0.83
NIC	I <sub>2</sub> ,R <sub>1</sub>	50	34.0	38.0	24.0	4.0	0.0	4.0	0.86
NIC	I <sub>2</sub> ,R <sub>2</sub>	51	54.9	41.2	3.9	0.0	0.0	4.5	0.57
NIC	I <sub>2</sub> ,R <sub>3</sub>	51	27.5	47.1	25.5	0.0	0.0	4.0	0.73
NIC	I <sub>3</sub> ,R <sub>2</sub>	51	27.5	70.6	2.0	0.0	0.0	4.3	0.48
NIC	I <sub>3</sub> ,R <sub>3</sub>	51	35.3	35.3	29.4	0.0	0.0	4.1	0.80
NIC	I <sub>4</sub> ,R <sub>3</sub>	51	21.6	41.2	33.3	3.9	0.0	3.8	0.82
NIC	I <sub>5</sub> ,R <sub>4</sub>	51	2.0	7.8	54.9	33.3	2.0	2.8	0.71
ADPCM	I <sub>1</sub> ,R <sub>1</sub>	51	33.3	43.1	15.7	7.8	0.0	4.0	0.90
ADPCM	I <sub>1</sub> ,R <sub>2</sub>	50	18.0	46.0	28.0	8.0	0.0	3.7	0.84
ADPCM	I <sub>2</sub> ,R <sub>1</sub>	51	31.4	43.1	19.6	3.9	2.0	4.0	0.92
ADPCM	I <sub>2</sub> ,R <sub>2</sub>	51	35.3	52.9	11.8	0.0	0.0	4.2	0.64
ADPCM	I <sub>2</sub> ,R <sub>3</sub>	50	4.0	38.0	48.0	10.0	0.0	3.4	0.71
ADPCM	I <sub>3</sub> ,R <sub>2</sub>	50	34.0	40.0	14.0	12.0	0.0	4.0	0.98
ADPCM	I <sub>3</sub> ,R <sub>3</sub>	51	11.8	41.2	39.2	7.8	0.0	3.6	0.80
ADPCM	I <sub>4</sub> ,R <sub>3</sub>	51	15.7	45.1	39.2	0.0	0.0	3.8	0.70
ADPCM	I <sub>5</sub> ,R <sub>4</sub>	51	0.0	15.7	49.0	31.4	3.9	2.8	0.76
SLC™	I <sub>1</sub> ,R <sub>1</sub>	51	17.7	37.3	35.3	9.8	0.0	3.6	0.88
SLC	I <sub>1</sub> ,R <sub>2</sub>	50	16.0	36.0	42.0	6.0	0.0	3.6	0.82
SLC	I <sub>2</sub> ,R <sub>1</sub>	51	43.1	31.4	15.7	9.8	0.0	4.1	0.99
SLC	I <sub>2</sub> ,R <sub>2</sub>	51	21.6	54.9	23.5	0.0	0.0	4.0	0.67
SLC	I <sub>2</sub> ,R <sub>3</sub>	51	19.6	47.1	29.4	3.9	0.0	3.8	0.78
SLC	I <sub>3</sub> ,R <sub>2</sub>	50	34.0	52.0	14.0	0.0	0.0	4.2	0.66
SLC	I <sub>3</sub> ,R <sub>3</sub>	51	7.8	43.1	37.3	11.8	0.0	3.5	0.80
SLC	I <sub>4</sub> ,R <sub>3</sub>	51	3.9	7.8	60.8	27.5	0.0	2.9	0.70
SLC	I <sub>5</sub> ,R <sub>4</sub>	50	0.0	18.0	42.0	40.0	0.0	2.8	0.73
Noise 10 dBBrnC	R <sub>1</sub>	51	23.5	39.2	27.5	7.8	2.0	3.8	0.97
Noise 10 dBBrnC	R <sub>3</sub>	51	5.9	60.8	25.5	7.8	0.0	3.7	0.71
Noise 10 dBBrnC	R <sub>4</sub>	51	3.9	9.8	43.1	43.1	0.0	2.8	0.79
Noise 20 dBBrnC	R <sub>1</sub>	51	3.9	29.4	52.9	11.8	2.0	3.2	0.77
Noise 20 dBBrnC	R <sub>3</sub>	51	17.7	54.9	27.5	0.0	0.0	3.9	0.66
Noise 20 dBBrnC	R <sub>4</sub>	51	0.0	5.9	47.1	47.1	0.0	2.6	0.60
Noise 30 dBBrnC	R <sub>1</sub>	51	3.9	11.8	43.1	37.3	3.9	2.8	0.86
Noise 30 dBBrnC	R <sub>3</sub>	51	0.0	15.7	56.9	27.5	0.0	2.9	0.65
Noise 30 dBBrnC	R <sub>4</sub>	51	2.0	2.0	25.5	64.7	5.9	2.3	0.69
Noise 40 dBBrnC	R <sub>1</sub>	51	0.0	5.9	25.5	41.2	27.5	2.1	0.87
Noise 40 dBBrnC	R <sub>3</sub>	51	0.0	0.0	23.5	58.8	17.6	2.1	0.64
Noise 40 dBBrnC	R <sub>4</sub>	51	2.0	2.0	11.8	66.7	17.6	2.0	0.74
Q—5 dB	R <sub>1</sub>	51	0.0	0.0	5.9	19.6	74.5	1.3	0.58
Q—5 dB	R <sub>3</sub>	51	0.0	0.0	0.0	27.5	72.5	1.3	0.45
Q—5 dB	R <sub>4</sub>	51	0.0	0.0	0.0	15.7	84.3	1.2	0.36
Q—10 dB	R <sub>1</sub>	51	0.0	2.0	9.8	49.0	39.2	1.8	0.71
Q—10 dB	R <sub>3</sub>	51	0.0	0.0	11.8	62.7	25.5	1.9	0.59
Q—10 dB	R <sub>4</sub>	51	0.0	0.0	2.0	54.9	43.1	1.6	0.53
Q—15 dB	R <sub>1</sub>	51	9.8	7.8	51.0	29.4	2.0	2.9	0.92
Q—15 dB	R <sub>3</sub>	51	0.0	3.9	49.0	47.1	0.0	2.6	0.57
Q—15 dB	R <sub>4</sub>	51	0.0	5.9	7.8	70.6	15.7	2.0	0.68
Q—20 dB	R <sub>1</sub>	51	15.7	35.3	41.2	7.8	0.0	3.6	0.84
Q—20 dB	R <sub>3</sub>	51	3.9	23.5	54.9	17.6	0.0	3.1	0.74

(continued)

Table VI (cont)

Q-20 dB	R <sub>4</sub>	51	0.0	3.9	37.3	52.9	5.9	2.4	0.66
Q-25 dB	R <sub>1</sub>	50	32.0	34.0	26.0	8.0	0.0	3.9	0.94
Q-25 dB	R <sub>3</sub>	51	7.8	39.2	39.2	13.7	0.0	3.4	0.82
Q-25 dB	R <sub>4</sub>	51	9.8	13.7	43.1	27.5	5.9	2.9	1.02

## Notation:

PCM = 48-kb/s 15-segment PCM (mid-tread)

NIC = 51-kb/s NIC PCM

ADPCM = 48-kb/s ADPCM (with step-size leak)

SLC = 48-kb/s SLC ADM

I<sub>1</sub>, I<sub>2</sub>, I<sub>3</sub>, I<sub>4</sub>, and I<sub>5</sub> = input levels of -0.2, -10.5, -20.7, -31.0, and -41.2 VU, respectivelyR<sub>1</sub>, R<sub>2</sub>, R<sub>3</sub>, and R<sub>4</sub> = received volumes of -20.7, -29.0, -38.3, and -47.0 VU, respectively

Table VII—Detailed tabulation of subjective scoring for single encoding vs error rate tests

Codec	Error Rate	Votes	% Exc.	% Good	% Fair	% Poor	% Uns.	MOS	$\sigma$
PCM	10 <sup>-1</sup>	207	0.0	0.0	0.0	3.4	96.6	1.0	0.18
PCM	10 <sup>-2</sup>	204	0.0	2.0	8.3	63.2	26.5	1.9	0.64
PCM	10 <sup>-3</sup>	207	0.5	17.9	66.7	15.0	0.0	3.0	0.59
PCM	10 <sup>-4</sup>	207	31.4	41.1	26.6	0.5	0.5	4.0	0.80
PCM	10 <sup>-5</sup>	208	42.8	50.0	7.2	0.0	0.0	4.4	0.61
NIC	10 <sup>-1</sup>	208	0.0	0.0	0.5	7.7	91.8	1.1	0.30
NIC	10 <sup>-2</sup>	207	0.0	3.9	33.8	54.1	8.2	2.3	0.68
NIC	10 <sup>-3</sup>	207	12.1	46.4	39.1	2.4	0.0	3.7	0.71
NIC	10 <sup>-4</sup>	207	43.5	44.9	10.1	1.4	0.0	4.3	0.71
NIC	10 <sup>-5</sup>	208	52.4	41.8	5.8	0.0	0.0	4.5	0.60
ADPCM	10 <sup>-1</sup>	207	0.0	0.0	0.0	3.9	96.1	1.0	0.19
ADPCM	10 <sup>-2</sup>	206	0.0	1.5	16.5	65.0	17.0	2.0	0.63
ADPCM	10 <sup>-3</sup>	207	22.7	45.9	28.0	3.4	0.0	3.9	0.79
ADPCM	10 <sup>-4</sup>	208	35.1	52.4	12.0	0.5	0.0	4.2	0.66
ADPCM	10 <sup>-5</sup>	208	41.8	44.2	13.9	0.0	0.0	4.3	0.69
SLC™	10 <sup>-1</sup>	206	0.0	0.0	3.4	27.7	68.9	1.3	0.54
SLC	10 <sup>-2</sup>	206	1.0	17.5	55.3	25.2	1.0	2.9	0.71
SLC	10 <sup>-3</sup>	207	40.1	44.9	14.5	0.5	0.0	4.3	0.71
SLC	10 <sup>-4</sup>	206	46.1	44.7	9.2	0.0	0.0	4.4	0.65
SLC	10 <sup>-5</sup>	206	43.7	38.8	16.5	1.0	0.0	4.3	0.76
Noise 10 dBrnC		201	31.3	50.2	17.9	0.5	0.0	4.1	0.70
Noise 20 dBrnC		206	7.8	37.9	48.5	5.8	0.0	3.5	0.72
Noise 30 dBrnC		205	3.4	14.6	53.7	27.3	1.0	2.9	0.77
Noise 40 dBrnC		206	0.0	7.8	35.0	54.4	2.9	2.5	0.68
Q-10 dB		208	0.0	2.4	11.5	69.7	16.3	2.0	0.61
Q-20 dB		206	14.6	37.4	40.3	7.8	0.0	3.6	0.83

## Notation:

PCM = 48-kb/s 15-segment PCM (mid-tread)

NIC = 51-kb/s NIC PCM

ADPCM = 48-kb/s ADPCM (with step-size leak)

SLC = 48-kb/s SLC ADM

Table VIII—Detailed tabulation of subjective scoring for number of codecs in tandem

Codec	Tandem Encodings	Votes	% Exc.	% Good	% Fair	% Poor	% Uns.	MOS	$\sigma$
PCM	1	106	35.9	55.7	6.6	1.9	0.0	4.3	0.66
PCM	2	105	41.9	45.7	11.4	1.0	0.0	4.3	0.70
PCM	4	106	22.6	60.4	14.2	2.8	0.0	4.0	0.69
PCM	6	106	21.7	51.9	23.6	2.8	0.0	3.9	0.75
PCM	8	106	16.0	41.5	36.8	5.7	0.0	3.7	0.81

(continued)

Table VIII (cont)

PCM <sub>1</sub>	1	106	14.2	52.8	31.1	1.9	0.0	3.8	0.70
PCM <sub>1</sub>	2	106	12.3	34.9	46.2	6.6	0.0	3.5	0.79
PCM <sub>1</sub>	4	106	0.0	15.1	58.5	26.4	0.0	2.9	0.63
PCM <sub>1</sub>	8	106	0.0	2.8	34.0	53.8	9.4	2.3	0.68
NIC	1	106	7.5	51.9	33.0	7.5	0.0	3.6	0.74
NIC	2	106	2.8	34.9	42.5	19.8	0.0	3.2	0.79
NIC	4	106	0.0	7.5	34.0	46.2	12.3	2.4	0.79
NIC	8	106	0.0	0.9	13.2	48.1	37.7	1.8	0.70
ADPCM	1	106	22.6	41.5	31.1	4.7	0.0	3.8	0.83
ADPCM	2	105	1.9	34.3	49.5	14.3	0.0	3.2	0.71
ADPCM	4	106	0.9	8.5	49.1	39.6	1.9	2.7	0.70
ADPCM	8	106	0.0	0.9	17.9	53.8	27.4	1.9	0.70
SLC™	1	104	27.9	40.4	26.0	4.8	1.0	3.9	0.90
SLC	2	105	13.3	45.7	33.3	6.7	1.0	3.6	0.83
SLC	4	106	0.9	10.4	44.3	42.5	1.9	2.7	0.73
SLC	8	106	0.0	1.9	26.4	47.2	24.5	2.1	0.76
ADPCM*	1 (at 16 kb/s)	106	0.0	1.0	13.2	41.5	44.3	1.7	0.73
ADPCM*	1 (at 24 kb/s)	106	0.0	11.3	52.8	32.1	3.8	2.7	0.71
ADPCM*	1 (at 32 kb/s)	105	29.5	41.0	25.7	3.8	0.0	4.0	0.84
ADPCM*	1 (at 48 kb/s)	106	26.4	50.9	21.7	1.0	0.0	4.0	0.72

\* ADPCM conditions (without step-size leak) which tie into those of Table V.

Notation:

PCM = 64-kb/s 15-segment PCM (mid-tread)

PCM<sub>1</sub> = 48-kb/s 15-segment PCM (mid-tread)

NIC = 35-kb/s NIC PCM

ADPCM = 32-kb/s ADPCM (without step-size leak)

SLC = 37.7-kb/s SLC ADM

Table IX—Detailed tabulation of subjective scoring for local reference connection tests

Connection	Votes	% Exc.	% Good	% Fair	% Poor	% Uns.	MOS	$\sigma$
AL-ACO-AL	106	25.5	55.7	16.0	2.8	0.0	4.0	0.73
AL-DCO-AL	106	22.6	55.7	18.9	2.8	0.0	4.0	0.73
AL-ACO-P	106	9.4	57.5	29.2	3.8	0.0	3.7	0.68
AL-ACO-P <sub>1</sub>	105	6.7	40.0	39.0	13.3	1.0	3.4	0.83
AL-ACO-N	106	3.8	34.0	50.0	12.3	0.0	3.3	0.73
AL-ACO-A	106	15.1	37.7	41.5	5.7	0.0	3.6	0.81
AL-ACO-S	106	4.7	51.9	38.7	4.7	0.0	3.6	0.66
P-ACO-AL	105	17.1	51.4	28.6	2.9	0.0	3.8	0.74
P <sub>1</sub> -ACO-AL	106	6.6	43.4	41.5	7.5	0.9	3.5	0.77
N-ACO-AL	106	1.9	37.7	51.9	7.5	0.9	3.3	0.68
A-ACO-AL	106	3.8	47.2	40.6	8.5	0.0	3.5	0.70
S-ACO-AL	106	6.6	53.8	34.0	5.7	0.0	3.6	0.69
P-ACO-P	106	10.4	55.7	33.0	0.9	0.0	3.8	0.64
P <sub>1</sub> -ACO-P <sub>1</sub>	104	5.8	33.7	50.0	10.6	0.0	3.4	0.74
N-ACO-N	106	1.9	29.2	36.8	27.4	4.7	3.0	0.91
A-ACO-A	106	3.8	28.3	53.8	13.2	0.9	3.2	0.75
S-ACO-S	106	0.9	26.4	59.4	13.2	0.0	3.2	0.64
P-ACO-P <sub>1</sub>	105	2.9	39.0	51.4	5.7	0.9	3.4	0.68
P-ACO-N	106	0.9	27.4	54.7	17.0	0.0	3.1	0.68
P-ACO-A	106	4.7	30.2	54.7	10.4	0.0	3.3	0.71
P-ACO-S	105	2.9	55.2	38.1	3.8	0.0	3.6	0.62
P <sub>1</sub> -ACO-P	106	5.7	45.3	38.7	10.4	0.0	3.5	0.75
P <sub>1</sub> -ACO-N	106	0.9	17.9	61.3	19.8	0.0	3.0	0.64
P <sub>1</sub> -ACO-A	106	0.9	15.1	63.2	19.8	0.9	3.0	0.65
P <sub>1</sub> -ACO-S	106	1.9	33.0	50.9	14.2	0.0	3.2	0.70
N-ACO-P	106	0.9	33.0	51.9	12.3	1.9	3.2	0.73
N-ACO-P <sub>1</sub>	106	2.8	17.0	48.1	29.2	2.8	2.9	0.82
N-ACO-A	105	1.9	26.7	55.2	15.2	1.0	3.1	0.72
N-ACO-S	106	0.9	32.1	50.9	16.0	0.0	3.2	0.70
A-ACO-P	105	7.6	34.3	52.4	5.7	0.0	3.4	0.72
A-ACO-P <sub>1</sub>	105	3.8	28.6	48.6	18.1	1.0	3.2	0.79
A-ACO-N	104	0.0	14.4	58.7	25.0	1.9	2.9	0.67

(continued)

Table IX (cont)

A-ACO-S	106	3.8	31.1	52.8	12.3	0.0	3.3	0.72
S-ACO-P	106	4.7	44.3	47.2	3.8	0.0	3.5	0.65
S-ACO-P <sub>1</sub>	106	0.0	14.2	55.7	29.2	0.9	2.8	0.67
S-ACO-N	106	1.9	24.5	52.8	19.8	0.9	3.1	0.74
S-ACO-A	106	0.0	18.9	67.0	14.2	0.0	3.1	0.57

## Notation:

- P = 64-kb/s 15-segment PCM (mid-tread)  
P<sub>1</sub> = 48-kb/s 15-segment PCM (mid-tread)  
N = 35-kb/s NIC PCM  
A = 32-kb/s ADPCM (without step-size leak)  
S = 37.7-kb/s SLC ADM  
AL = analog loop  
ACO = analog central office  
DCO = digital central office

Table X—Detailed tabulation of subjective scoring for exchange reference connection tests

Connection	Votes	% Exc.	% Good	% Fair	% Poor	% Uns.	MOS	$\sigma$
AL-ACO-AEX-ACO-AL	106	7.5	49.1	39.6	3.8	0.0	3.6	0.68
P-ACO-P-ACO-P	106	5.7	37.7	54.7	1.9	0.0	3.5	0.63
P <sub>1</sub> -ACO-P <sub>1</sub> -ACO-P <sub>1</sub>	106	3.8	23.6	40.6	27.4	4.7	2.9	0.92
N-ACO-N-ACO-N	106	0.0	7.5	44.3	42.5	5.7	2.5	0.72
A-ACO-A-ACO-A	105	0.0	12.4	61.0	21.0	5.7	2.8	0.72
S-ACO-S-ACO-S	106	0.0	7.5	61.3	30.2	0.9	2.8	0.60
P-DCO-P-DCO-P	106	36.8	50.0	13.2	0.0	0.0	4.2	0.67
P <sub>1</sub> -DCO-P <sub>1</sub> -DCO-P <sub>1</sub>	106	14.2	60.4	19.8	5.7	0.0	3.8	0.73
N-DCO-N-DCO-N	106	10.4	50.9	36.8	1.9	0.0	3.7	0.68
A-DCO-A-DCO-A	106	15.1	47.2	32.1	5.7	0.0	3.7	0.79
S-DCO-S-DCO-S	105	1.9	11.4	60.0	25.7	1.0	2.9	0.69
Noise 10 dB <sub>BrnC</sub>	212	20.3	56.6	23.1	0.0	0.0	4.0	0.66
Noise 20 dB <sub>BrnC</sub>	211	2.8	29.9	47.9	16.6	2.8	3.1	0.82
Noise 30 dB <sub>BrnC</sub>	211	0.0	8.5	30.8	46.9	13.7	2.3	0.82
Noise 40 dB <sub>BrnC</sub>	212	0.0	1.9	11.8	44.8	41.5	1.7	0.74
Q-5 dB	212	0.0	0.0	0.0	10.8	89.2	1.1	0.31
Q-10 dB	211	0.0	0.9	9.0	39.8	50.2	1.6	0.69
Q-15 dB	211	0.9	5.7	37.4	46.0	10.0	2.4	0.78
Q-20 dB	211	5.7	30.3	47.4	16.1	0.5	3.3	0.81
Q-25 dB	210	32.4	48.6	15.7	3.3	0.0	4.1	0.78

## Notation:

- P = 64-kb/s 15-segment PCM (mid-tread)  
P<sub>1</sub> = 48-kb/s 15-segment PCM (mid-tread)  
N = 35-kb/s NIC PCM  
A = 32-kb/s ADPCM (without step-size leak)  
S = 37.7-kb/s SLC ADM  
AL = analog loop  
ACO = analog central office  
DCO = digital central office  
AEX = analog exchange trunk

Table XI—Detailed tabulation of subjective scoring for toll reference connection conditions—part 1

Connection	Votes	% Exc.	% Good	% Fair	% Poor	% Uns.	MOS	$\sigma$
AL-S <sub>1</sub> -AL	112	17.0	58.0	22.3	2.7	0.0	3.9	0.70
AL-S <sub>1</sub> -P	102	19.6	50.0	30.4	0.0	0.0	3.9	0.70
AL-S <sub>1</sub> -P <sub>1</sub>	111	12.6	42.3	36.0	9.0	0.0	3.6	0.82
AL-S <sub>1</sub> -N	112	2.7	35.7	47.3	13.4	0.9	3.3	0.75
AL-S <sub>1</sub> -A	112	10.7	44.6	38.4	6.3	0.0	3.6	0.76
AL-S <sub>1</sub> -S	111	5.4	54.1	35.1	5.4	0.0	3.6	0.68
AL-S <sub>2</sub> -AL	111	30.6	49.5	18.0	1.8	0.0	4.1	0.74
AL-S <sub>2</sub> -P	112	18.8	56.3	23.2	1.8	0.0	3.9	0.70
AL-S <sub>2</sub> -P <sub>1</sub>	111	9.9	53.2	30.6	5.4	0.9	3.7	0.77
AL-S <sub>2</sub> -N	112	6.3	36.6	40.2	17.0	0.0	3.3	0.83
AL-S <sub>2</sub> -A	102	8.8	40.2	41.2	9.8	0.0	3.5	0.79
AL-S <sub>2</sub> -S	112	14.3	43.8	36.6	5.4	0.0	3.7	0.78
AL-S <sub>3</sub> -AL	112	25.9	57.1	15.2	1.8	0.0	4.1	0.69
AL-S <sub>3</sub> -P	112	30.4	50.0	19.6	0.0	0.0	4.1	0.70
AL-S <sub>3</sub> -P <sub>1</sub>	102	11.8	43.1	41.2	3.9	0.0	3.6	0.74
AL-S <sub>3</sub> -N	102	7.8	43.1	41.2	7.8	0.0	3.5	0.75
AL-S <sub>3</sub> -A	102	4.9	43.1	41.2	10.8	0.0	3.4	0.75
AL-S <sub>3</sub> -S	112	15.2	49.1	30.4	5.4	0.0	3.7	0.78
AL-L <sub>1</sub> -AL	111	2.7	15.3	51.4	27.0	3.6	2.9	0.81
AL-L <sub>1</sub> -P	112	1.8	19.6	49.1	28.6	0.9	2.9	0.76
AL-L <sub>1</sub> -P <sub>1</sub>	112	0.9	16.1	55.4	27.7	0.0	2.9	0.68
AL-L <sub>1</sub> -N	102	1.0	10.8	50.0	37.3	1.0	2.7	0.70
AL-L <sub>1</sub> -A	112	0.9	10.7	50.0	35.7	2.7	2.7	0.72
AL-L <sub>1</sub> -S	101	1.0	20.8	51.5	26.7	0.0	3.0	0.72
AL-L <sub>2</sub> -AL	112	1.8	14.3	52.7	31.3	0.0	2.9	0.71
AL-L <sub>2</sub> -P	111	2.7	28.8	46.8	21.6	0.0	3.1	0.77
AL-L <sub>2</sub> -P <sub>1</sub>	111	0.9	13.5	55.0	30.6	0.0	2.9	0.67
AL-L <sub>2</sub> -N	112	0.0	13.4	51.8	33.9	0.9	2.8	0.68
AL-L <sub>2</sub> -A	111	0.9	9.9	57.7	29.7	1.8	2.8	0.68
AL-L <sub>2</sub> -S	111	1.8	21.6	54.1	22.5	0.0	3.0	0.72
AL-L <sub>3</sub> -AL	112	17.9	62.5	18.8	0.9	0.0	4.0	0.63
AL-L <sub>3</sub> -P	112	13.4	50.0	32.1	4.5	0.0	3.7	0.75
AL-L <sub>3</sub> -P <sub>1</sub>	112	10.7	45.5	40.2	3.6	0.0	3.6	0.72
AL-L <sub>3</sub> -N	112	8.0	43.8	41.1	7.1	0.0	3.5	0.74
AL-L <sub>3</sub> -A	112	8.0	42.0	42.0	8.0	0.0	3.5	0.76
AL-L <sub>3</sub> -S	112	5.4	39.3	47.3	8.0	0.0	3.4	0.72
AL-W-AL	112	1.8	20.5	58.9	18.8	0.0	3.1	0.68
AL-W-P	112	1.8	10.7	53.6	33.9	0.0	2.8	0.69
AL-W-P <sub>1</sub>	102	2.0	6.9	54.9	35.3	1.0	2.7	0.68
AL-W-N	101	0.0	9.9	47.5	41.6	1.0	2.7	0.66
AL-W-A	112	1.8	7.1	51.8	39.3	0.0	2.7	0.67
AL-W-S	112	0.0	10.7	55.4	33.0	0.9	2.8	0.64
AL-D-AL	111	39.6	48.6	10.8	0.9	0.0	4.3	0.68
AL-D-P	102	29.4	53.9	14.7	2.0	0.0	4.1	0.71
AL-D-P <sub>1</sub>	112	17.9	53.6	26.8	1.8	0.0	3.9	0.71
AL-D-N	112	8.0	33.9	45.5	12.5	0.0	3.4	0.80
AL-D-A	112	18.8	57.1	20.5	3.6	0.0	3.9	0.73
AL-D-S	111	22.5	38.7	34.2	4.5	0.0	3.8	0.84
Noise 10 dBBrnC	224	44.2	46.0	9.8	0.0	0.0	4.3	0.65
Noise 20 dBBrnC	214	3.7	43.9	47.7	4.7	0.0	3.5	0.65
Noise 30 dBBrnC	214	0.9	15.0	48.6	34.6	0.9	2.8	0.73
Noise 40 dBBrnC	224	0.0	2.7	29.0	60.7	7.6	2.3	0.63
Q—5 dB	223	0.0	0.0	0.0	21.1	78.9	1.2	0.41
Q—10 dB	226	0.0	0.0	7.1	51.3	41.6	1.7	0.61
Q—15 dB	223	0.0	5.8	37.7	43.9	12.6	2.4	0.77
Q—20 dB	214	13.1	23.4	37.9	23.8	1.9	3.2	1.01
Q—25 dB	224	32.1	43.8	21.0	3.1	0.0	4.1	0.81

Notation:

P, P<sub>1</sub>, N, A, S, AL—see Table X

S<sub>1</sub>, S<sub>2</sub>, S<sub>3</sub>, L<sub>1</sub>, L<sub>2</sub>, L<sub>3</sub>, W, D—see Figs. 19a, 19b, and 19c in text.

Table XII—Detailed tabulation of subjective scoring  
for toll reference connection conditions—part 2

Connection	Votes	% Exc.	% Good	% Fair	% Poor	% Uns.	MOS	$\sigma$
P-S <sub>1</sub> -P	108	40.7	50.0	9.3	0.0	0.0	4.3	0.63
P <sub>1</sub> -S <sub>1</sub> -P <sub>1</sub>	108	10.2	48.1	37.0	4.6	0.0	3.6	0.73
N-S <sub>1</sub> -N	107	2.8	26.2	51.4	17.8	1.9	3.1	0.78
A-S <sub>1</sub> -A	108	13.9	35.2	35.2	15.7	0.0	3.5	0.92
S-S <sub>1</sub> -S	108	6.5	45.4	41.7	6.5	0.0	3.5	0.71
P-S <sub>2</sub> -P	108	23.1	64.8	12.0	0.0	0.0	4.1	0.58
P <sub>1</sub> -S <sub>2</sub> -P <sub>1</sub>	107	16.8	50.5	29.9	2.8	0.0	3.8	0.74
N-S <sub>2</sub> -N	108	6.5	23.1	55.6	14.8	0.0	3.2	0.77
A-S <sub>2</sub> -A	108	5.6	33.3	52.8	8.3	0.0	3.4	0.71
S-S <sub>2</sub> -S	108	13.9	51.9	28.7	5.6	0.0	3.7	0.76
P-S <sub>3</sub> -P	108	31.5	56.5	10.2	1.9	0.0	4.2	0.68
P <sub>1</sub> -S <sub>3</sub> -P <sub>1</sub>	107	11.2	38.3	44.9	4.7	0.9	3.5	0.79
N-S <sub>3</sub> -N	108	2.8	34.3	43.5	17.6	1.9	3.2	0.82
A-S <sub>3</sub> -A	106	3.8	34.0	53.8	8.5	0.0	3.3	0.68
S-S <sub>3</sub> -S	107	14.0	50.5	29.9	5.6	0.0	3.7	0.77
P-L <sub>1</sub> -P	108	0.0	13.0	59.3	27.8	0.0	2.9	0.62
P <sub>1</sub> -L <sub>1</sub> -P <sub>1</sub>	108	0.0	10.2	59.3	30.6	0.0	2.8	0.60
N-L <sub>1</sub> -N	108	0.0	8.3	60.2	28.7	2.8	2.7	0.64
A-L <sub>1</sub> -A	108	0.0	6.5	54.6	38.0	0.9	2.7	0.61
S-L <sub>1</sub> -S	107	0.0	4.7	57.0	37.4	0.9	2.7	0.58
P-L <sub>2</sub> -P	108	0.0	17.6	58.3	24.1	0.0	2.9	0.64
P <sub>1</sub> -L <sub>2</sub> -P <sub>1</sub>	108	0.0	7.4	61.1	28.7	2.8	2.7	0.63
N-L <sub>2</sub> -N	107	0.0	4.7	57.9	35.5	1.9	2.7	0.60
A-L <sub>2</sub> -A	108	0.0	6.5	58.3	34.3	0.9	2.7	0.60
S-L <sub>2</sub> -S	108	0.0	5.6	60.2	33.3	0.9	2.7	0.58
P-L <sub>3</sub> -P	106	17.9	60.4	21.7	0.0	0.0	4.0	0.63
P <sub>1</sub> -L <sub>3</sub> -P <sub>1</sub>	108	12.0	49.1	33.3	5.6	0.0	3.7	0.76
N-L <sub>3</sub> -N	107	1.9	27.1	56.1	15.0	0.0	3.2	0.69
A-L <sub>3</sub> -A	108	6.5	35.2	50.0	8.3	0.0	3.4	0.73
S-L <sub>3</sub> -S	107	2.8	47.7	42.1	7.5	0.0	3.5	0.67
P-W-P	108	0.0	13.9	63.0	22.2	0.9	2.9	0.62
P <sub>1</sub> -W-P <sub>1</sub>	108	0.0	8.3	59.3	31.5	0.9	2.8	0.61
N-W-N	107	0.0	1.9	52.3	44.9	0.9	2.6	0.55
A-W-A	106	0.0	2.8	57.5	37.7	1.9	2.6	0.58
S-W-S	108	0.0	6.5	56.5	36.1	0.9	2.7	0.60
P-D-P	108	37.0	51.9	10.2	0.9	0.0	4.3	0.67
P <sub>1</sub> -D-P <sub>1</sub>	106	18.9	43.4	33.0	4.7	0.0	3.8	0.81
N-D-N	108	0.9	37.0	50.0	12.0	0.0	3.3	0.68
A-D-A	107	13.1	40.2	38.3	8.4	0.0	3.6	0.82
S-D-S	108	17.6	50.0	31.5	0.9	0.9	3.8	0.71
Noise 10 dB <sub>BrnC</sub>	216	45.8	44.4	9.7	0.0	0.0	4.4	0.65
Noise 20 dB <sub>BrnC</sub>	215	8.4	52.1	36.7	2.8	0.0	3.7	0.67
Noise 30 dB <sub>BrnC</sub>	214	1.4	13.6	52.8	30.8	1.4	2.8	0.73
Noise 40 dB <sub>BrnC</sub>	216	0.0	0.0	24.5	58.8	16.7	2.1	0.64
Q—5 dB	215	0.0	0.0	0.0	16.7	83.3	1.2	0.37
Q—10 dB	216	0.0	0.0	9.7	54.2	36.1	1.7	0.62
Q—15 dB	215	0.9	9.8	38.6	46.0	4.7	2.6	0.77
Q—20 dB	213	12.7	36.6	41.8	8.9	0.0	3.5	0.83
Q—25 dB	216	50.0	38.4	10.6	0.9	0.0	4.4	0.71

Notation:  
See Table XI.

## REFERENCES

1. J. E. Abate, L. H. Bradenburg, J. C. Lawson, and W. L. Ross, "The Switched Digital Network Plan," *B.S.T.J.*, 56, No. 7 (September 1977), pp. 1297-1320.
2. J. R. Cavanaugh, R. W. Hatch, and J. L. Sullivan, "Models for the Subjective Effects of Loss, Noise, and Talker Echo on Telephone Connections," *B.S.T.J.*, 55, No. 9 (November 1976), pp. 1319-1371.
3. B. Smith, "Instantaneous Companding of Quantized Signals," *B.S.T.J.*, 36, No. 3 (May 1957), pp. 653-709.
4. C. L. Dammann, L. D. McDaniel, and C. L. Maddox, "Multiplexing and Coding," *B.S.T.J.*, 51, No. 8 (October 1972), pp. 1675-1700.
5. D. L. Duttweiler and D. G. Messerschmitt, "Nearly Instantaneous Companding for Nonuniformly Quantized PCM," *IEEE Trans. on Comm.*, COM-24 (August 1976), pp. 864-873.
6. P. Cummiskey, N. S. Jayant, and J. L. Flanagan, "Adaptive Quantization in Differential PCM Coding of Speech," *B.S.T.J.*, 52, No. 7 (September 1973), pp. 1105-1118.
7. R. J. Canniff, "Signal Processing in SLC-40, A 40 Channel Rural Subscriber Carrier," *IEEE ICC 1975*, June 16-18, Conference Record, Vol. 3, pp. 40-7 to 40-11.
8. W. R. Daumer, "A Digital Codec Simulation Facility," *IEEE Trans. on Comm.*, COM-26 (May 1978), pp. 665-669.
9. Annex 2 (Status of Noise Reference Unit Instrumentation) of Question 18/XII (Transmission Performance of Pulse-Code Modulation Systems), C.C.I.T.T. Green Book, Vol. V, published by The International Telecommunications Union, 1973.
10. K. L. McAdoo, "Speech Volumes on Bell System Message Circuits," *B.S.T.J.*, 42, No. 5 (September 1963), pp. 1999-2012.
11. F. P. Duffy and T. W. Thatcher, Jr., "Analog Transmission Performance on the Switched Telecommunications Network," *B.S.T.J.*, 50, No. 4 (April 1971), pp. 1311-1348.
12. R. A. Friedenson, R. W. Daniels, R. J. Dow, and P. H. McDonald, "RC Active Filters for the D3 Channel Bank," *B.S.T.J.*, 54, No. 3 (March 1975), pp. 507-530.
13. P. A. Gresh, "Physical and Transmission Characteristics of Customer Loop Plant," *B.S.T.J.*, 48, No. 10 (December 1969), pp. 3337-3386.
14. J. E. Kessler, "The Transmission Performance of Bell System Toll Connecting Trunks," *B.S.T.J.*, 50, No. 8 (October 1971), pp. 2741-2776.

