

Analytical Foundation for Low-Frequency Power-Telephone Interference

By J. C. PARKER, JR.

(Manuscript received June 30, 1977)

The mechanisms of interference at voice-band frequencies from a power distribution system which adversely affect the telephone loop plant are systematically described. A unified derivation is presented of simple lumped-element circuit models for telephone plant coupling, shielding, and longitudinal-to-metallic conversion. This approach establishes both qualitative understanding and quantitative analytical tools for characterizing the effects of low frequency interference. A glossary is included which represents a consensus evaluation of the best contemporary relationship between historical terminology and modern analytical viewpoints.

I. INTRODUCTION

This paper explores a systematic approach for understanding the electromagnetic interaction between power and telephone systems. Historically, the various mechanisms of coupling, shielding, and longitudinal-to-metallic conversion have evolved into separately addressed concerns. This has led to useful insight but somewhat narrow understanding, since the interdependence of the various concepts has received limited consideration. Moreover, since some of the classical treatments extend back over five decades, they are sometimes difficult to read owing to variations in terminology and basic units. We wish to provide a cohesive overview that emphasizes the interrelationship among these topics within a modern analytical setting. This approach, using concepts familiar to recent engineering graduates, unifies historical developments and provides a basis for understanding current viewpoints toward reducing power-telephone interaction.

Although transmission line theory is briefly touched upon as a starting point, the basic framework consists of an analytical model that utilizes only lumped-element circuit theory. This lumped-element general analytical model serves the following purposes. First, it ties together within

one framework a description of the various physical mechanisms that have previously been treated separately. Second, it readily lends itself to systematic computer evaluation of the electromagnetic interaction between these mechanisms. Finally, from this general model is derived several specialized circuit representations of a sufficiently simple nature to furnish maximum physical insight. These specialized circuits highlight the specific and well-known physical mechanisms of inductive, capacitive, and dissipative coupling, inductive shielding, and longitudinal-to-metallic conversion. A practitioner may utilize the more comprehensive analytical model, or he may wish to adopt the specialized circuit representations as his basis for understanding, depending on the extent of his concerns. The general analytical model retains its conceptual value as the origin of a single unified approach since it assures that the specialized models provide a consistent description. The usefulness of the various models is indicated in the summary section.

II. GENERAL ANALYTICAL MODEL

Although electromagnetic theory forms a fundamental core from which all macroscopic electrical behavior can be derived, it would be a rather remote starting point for the purposes of this discussion. On the other hand, the overall generality of our useful circuit models might well go unappreciated or else be questioned in the absence of a clear understanding of their origin. To strike a balance, this paper will adopt transmission line theory as a starting point, then move quickly to more familiar lumped-element circuit equations and models.

The multiconductor transmission line theory is derivable from Maxwell's equations with remarkably few restrictions,¹ although in common textbooks generality is often swapped for expediency. Many intricate details involving specialized electromagnetic analysis can be succinctly summarized as transmission line parameters. The presence of all skin effect phenomena,² both within the metal conductors and more importantly the resistive earth, can be rigorously accounted for by the transmission line parameters. Since the circuit theory equations and associated models are evolved from transmission line theory, they too can account for all skin effect phenomena. Such phenomena manifest themselves in the form of circuit parameters that are no longer frequency-independent; i.e., the R , L , G , and C can take on frequency dependencies in accordance with rigorous solutions to electromagnetic boundary value problems. In this way, full advantage is taken of the relative simplicity and usefulness of lumped-element circuit theory while, at the same time, maintaining substantial generality.

2.1 *Transmission line synopsis*

A rather concise physical interpretation is stated here to aid in the

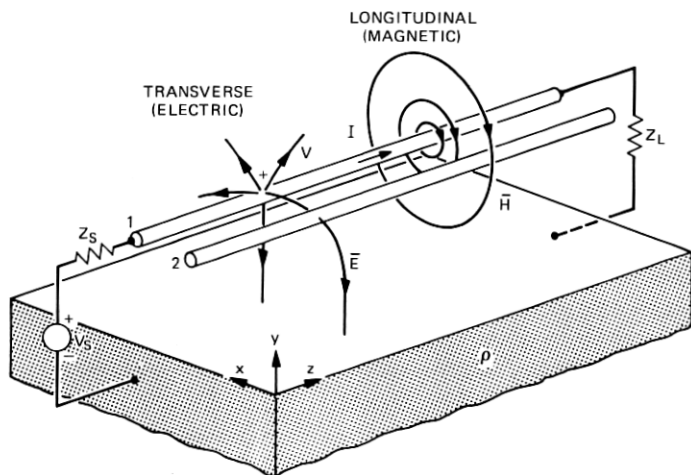

Fig. 1—Induction by electric and magnetic fields from disturbing into disturbed conductor.

understanding of transmission line equations and to instill confidence in their usefulness. While an understanding of these differential equations is highly desirable, their physical content carries over to the simpler algebraic equations to be introduced in the next section.

Consider two conductors located at fixed heights in relation to the surface of a resistive medium as illustrated in Fig. 1. Electromagnetic induction or coupling among parallel conductors may be classified as either transverse or longitudinal with respect to the conductor axes. Transverse coupling characterizes an electric force acting at right angles to the conductor and medium. This perpendicular force arises from an excess of charge that is proportional to conductor potential, V . Since the force acts to drain off and thereby deplete conductor current in the amount of $-dI$ within an incremental distance of dz , this coupling mechanism is described quantitatively by

$$-\frac{dI}{dz} = \mathcal{Y}V. \quad (1)$$

The proportionality factor \mathcal{Y} is called an incremental transverse admittance (mhos/meter). Longitudinal coupling, on the other hand, characterizes an electric force in the direction of the conductor axes. This axial force arises from the movement of charge that is proportional to conductor current, I . Since the axial electric force tends to decrease conductor potential with an increasing z , this coupling mechanism is described by

$$-\frac{dV}{dz} = ZI. \quad (2)$$

The proportionality factor Z is called an incremental longitudinal impedance (ohms/meter).

Equations (1) and (2) may be recognized as the simple transmission line equations found in basic textbooks.³ Such treatments often define V as the voltage difference between conductors 1 and 2 and take the I of conductor 1 to return entirely through conductor 2. This convention is appropriate when the two conductors are energized to form just one (metallic) circuit. More generally, a second (longitudinal) circuit is able to coexist on the two conductors. All possible circuits can be systematically taken into account by using the following reference convention. The voltage on each separate conductor is defined with respect to a common reference, in this case the finitely conducting earth which forms a "remote ground," as implied by the electric field lines in Fig. 1. Moreover, the current in each conductor is defined as having total "earth return," quite irrespective of the circuit's actual completion path. The relationship between this systematic "earth-return" reference convention and the useful longitudinal and metallic convention is more fully explored in Appendix B.

Equations (1) and (2) apply implicitly to multiconductor circuits.⁴ In this case V and I are taken as column vectors whose components associate with each individual conductor, while \mathcal{Y} and Z are taken as square symmetric matrices. The off-diagonal matrix elements represent "mutual coupling" effects, whereas the "self-reaction" of each conductor is characterized by the diagonal matrix elements. To illustrate this point, observe the matrix differential equations that characterize the two conductors in Fig. 1. The explicit matrix form of eq. (1) is

$$-\frac{d}{dz} \begin{bmatrix} I_1 \\ I_2 \end{bmatrix} = \begin{bmatrix} \mathcal{Y}_{11} & \mathcal{Y}_{12} \\ \mathcal{Y}_{21} & \mathcal{Y}_{22} \end{bmatrix} \begin{bmatrix} V_1 \\ V_2 \end{bmatrix}; \quad (3)$$

for eq. (2) it is

$$-\frac{d}{dz} \begin{bmatrix} V_1 \\ V_2 \end{bmatrix} = \begin{bmatrix} Z_{11} & Z_{12} \\ Z_{21} & Z_{22} \end{bmatrix} \begin{bmatrix} I_1 \\ I_2 \end{bmatrix}. \quad (4)$$

Each matrix equation is simply a compact notational expedient for representing a system of M coupled individual equations, where M (two in this case) is the number of conductors in the multiconductor transmission line. For instance, expanding this last matrix equation yields

$$\begin{aligned} -\frac{dV_1}{dz} &= Z_{11}I_1 + Z_{12}I_2 \\ -\frac{dV_2}{dz} &= Z_{21}I_1 + Z_{22}I_2, \end{aligned} \quad (5)$$

where Z_{12} (equal to Z_{21} from reciprocity) represents the longitudinal

mutual impedance/unit length which couples conductors 1 and 2. Matrix notation is exceedingly useful in subsequent developments and well worthy of the effort required to acquire familiarity. With this notation it becomes straightforward to systematically account for the interaction of neutral and multiple phase wires of the power system with the strand, sheath, and metallic circuit twisted pair conductors of the telephone system.

2.2 Segment model

A fortunate simplification arises owing to the telephone loop plant not being "long" when measured in relation to the wavelength of voiceband interference frequencies. A typical loop can be subdivided into a minimal number of electrically short segments, each of which is characterized by a fixed geometrical configuration. This allows the transmission line differential eqs. (1) and (2) to be replaced by much simpler lumped-element circuit equations. In addition, an equivalent circuit representation can be identified that will form the basis for all subsequent analyses. The more important details of this simplification are outlined below.

Consider an exposure segment of power and telephone system conductors with a uniform geometrical configuration and extending a length, $\Delta\ell$, between two locations identified as j and $j + 1$. The need for $\Delta\ell$ to be electrically short is generally not restricting at voiceband interference frequencies; this point is addressed more quantitatively in Appendix C. A general segment consisting of M individual conductors is illustrated schematically in Fig. 2a. Some conductors represent the power system neutral and phase wires; the remaining conductors can characterize such telephone system wires as a support strand, cable sheath, and twisted voice-circuit pairs. The nature of coaxial or cable-sheath-enclosed conductors is totally characterized by the numerical value of individual elements within the incremental impedance and admittance matrices. Moreover, these matrix elements also reflect spacing and height information. Since the conductor configurations may change from one segment to another, this variation will be identified by the superscript j , $j + 1$, on the incremental matrices that are applicable between locations j and $j + 1$. The column vectors representing voltage and current variables will also carry an appropriate superscript. The integer subscripts continue to represent specific conductors within matrices and column vectors.

In terms of the matrix notation described above, eq. (2) may be accurately approximated as

$$-\frac{(V^{j+1} - V^j)}{\Delta\ell} = Z^{j,j+1} I^{j,j+1}, \quad (6)$$

where $I^{j,j+1}$ is the current in the center of segment $j, j + 1$. Similarly, using an average value of voltage, eq. (1) becomes

$$\frac{(I_a^j + I_b^{j+1})}{\Delta\ell} = \mathcal{Y}^{j,j+1} \frac{(V^j + V^{j+1})}{2}. \quad (7)$$

In the above equation, the decrease in longitudinal current, $-dI$, between j and $j + 1$ has been identified with the transverse currents, I_a^j and I_b^{j+1} , which flow after and before the location identified by superscript. (These are the so-called charging currents associated with distributed capacitance of aerial cable, although they might also represent current flow due to distributed conductance of direct buried cable.) It is convenient to define total impedance and admittance matrices such that all elements of the incremental matrices are multiplied by the segment length, $\Delta\ell$:

$$Z^{j,j+1} \equiv Z^{j,j+1} \Delta\ell \quad (8)$$

$$Y^{j,j+1} \equiv \mathcal{Y}^{j,j+1} \Delta\ell. \quad (9)$$

Then, upon algebraic rearrangement eq. (6) becomes

$$V^j - V^{j+1} = Z^{j,j+1} I^{j,j+1} \begin{pmatrix} \text{longitudinal} \\ \text{impedance} \\ \text{coupling} \end{pmatrix}. \quad (10)$$

Similarly, the two independent terms on the right side of eq. (7) yield

$$\left. \begin{aligned} I_a^j &= Y_a^j V^j \\ I_b^{j+1} &= Y_b^{j+1} V^{j+1} \end{aligned} \right\} \begin{pmatrix} \text{transverse} \\ \text{admittance} \\ \text{coupling} \end{pmatrix}, \quad (11a)$$

$$(11b)$$

where

$$Y_a^j = Y_b^{j+1} \equiv \frac{1}{2} Y^{j,j+1} \quad (12)$$

has been defined in this decomposition. The circuit theory eqs. (10) and (11) are the desired replacements for the transmission line differential eqs. (1) and (2).

The foregoing basic circuit relationships completely characterize the physical coupling mechanisms, both longitudinal and transverse, within each segment of a power and telephone exposure. These equations lead directly to the equivalent circuit represented in a compact matrix form in Fig. 2b. The voltage and current variables are represented by column vectors, whose elements correspond to variables shown in Fig. 2a. The impedance and admittance elements represent square matrices. Observe that half the total segment admittance has been associated with the centers of each half-segment, occurring after location j and before

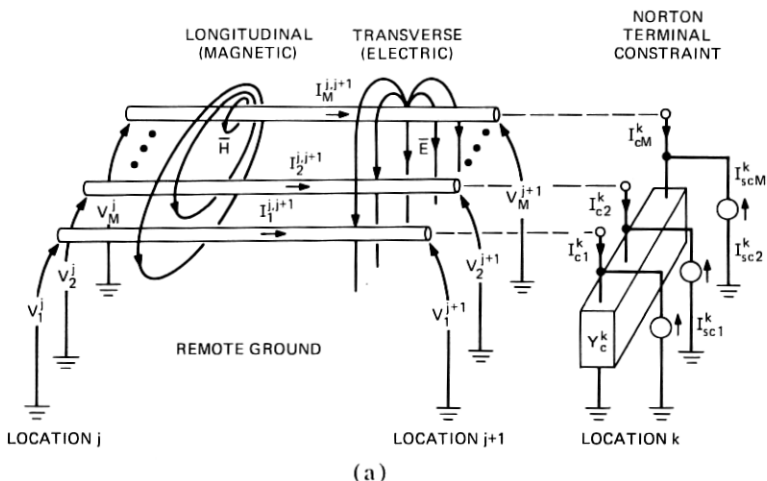

(a)

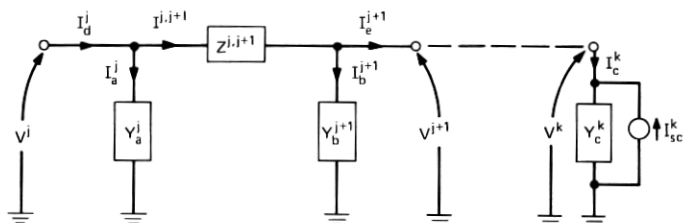

(b)

Fig. 2—Interaction model for multiconductor segments and general terminal constraint. (a) Nomenclature for matrix representation. (b) Equivalent circuit in compact matrix form.

location $j + 1$, in accordance with eq. (12). The total current which departs location j and flows into segment $j, j + 1$ is identifiable as

$$I_d^j = I^{j,j+1} + I_a^j \quad (13)$$

whereas the total current which enters location $j + 1$ from this segment is given by

$$I_e^{j+1} = I^{j,j+1} - I_b^{j+1} \quad (14)$$

In summary, all pertinent equations are implied by the equivalent circuit in Fig. 2b when analyzed with matrix algebra.

2.3 Constraint characterization

Now that a multiconductor exposure segment has been completely characterized in quantitative analytical terms starting from transmission

line concepts, the terminations or boundary conditions imposed at each end of a segment must be considered. The variety of terminations encountered in practice is rather substantial. For instance, the power system conductors will have load impedances and discrete grounding impedances attached at various locations. Generators will feed the power line from at least one end and possibly at two or more locations. The telephone system shielding conductors may be either independently grounded or resistively coupled to the power line ground. This resistive coupling may arise from the interaction of closely spaced ground rods or from direct bonding to the power system neutral conductor.

Each of these termination constraints could be implemented on a case-by-case basis for those relatively simple configurations that involve just a few conductors and one or two segments. Once the boundary conditions are characterized with individual circuits, the conglomerate network including the segment representation(s) must then be analyzed. There is a wide variety of network analysis techniques from which an efficient method can be selected. Generally, either mesh or node analysis is convenient for most simple networks.

Rather involved network configurations arise when considering the interactive effects of multiple shielding conductors and several cascaded exposure segments. For these cases it becomes highly desirable to invoke systematic network analysis techniques that lend themselves to straightforward computer implementation. It is possible to handle the wide variety of segment terminations (assumed linear) in a single versatile model by utilizing a Norton equivalent circuit to represent the general terminal constraint. When cast in matrix notation, these boundary conditions take the form:

$$I_c^k = Y_c^k V^k - I_{sc}^k \quad \left(\begin{array}{l} \text{general} \\ \text{terminal} \\ \text{constraint} \end{array} \right). \quad (15)$$

This approach has been illustrated in Fig. 2 by including a Norton terminal constraint for an arbitrary location k . With a Norton representation, the ideal short circuit current sources, I_{sc}^k , simply vanish for the special case of passive terminations, while the off-diagonal mutual terms in the admittance constraint matrix, Y_c^k , readily account for any resistive coupling from nonindependent grounding. Details concerning the explicit form of the termination circuit have been suppressed into an implicit equivalent characterization. This will serve to systematize the subsequent network analysis procedure. The motivation for choosing a Norton instead of a Thevenin equivalent circuit will be clarified in the following section.

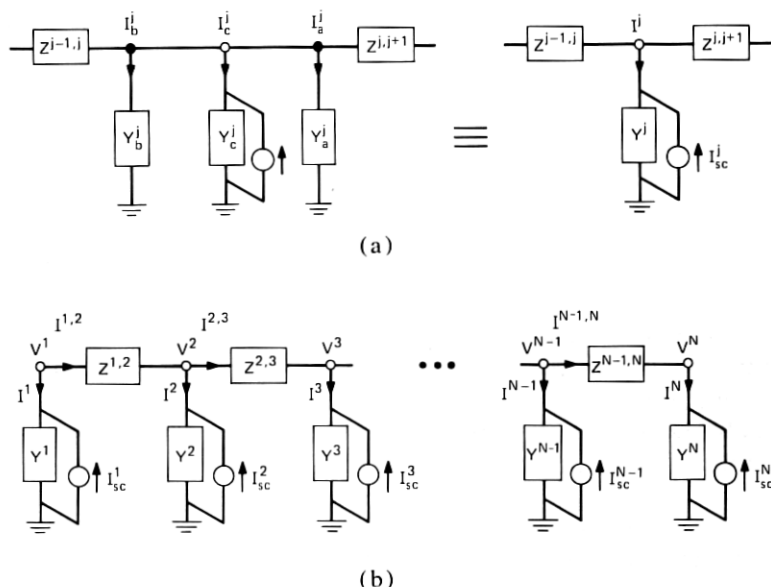

Fig. 3—Matrix representation of network model for many cascaded segments. (a) Simplification at adjoining segments. (b) Composite circuit for $N - 1$ segments.

2.4 Cascaded configuration

Circuit models have been derived for a multiconductor exposure segment and for a general terminal constraint in the preceding sections. With this building-block approach in mind, these circuits can now be combined to form the general network illustrated in Fig. 3. This network enables analyzing the effects of many exposure segments connected in cascade, while incorporating various grounding and bonding constraints at the segment interfaces. Thus, it becomes a fundamental tool from which to assess electromagnetic interaction between the power distribution system and telephone loop plant. This interaction varies with the configuration changes that occur along the loop plant. Physical parameters amenable to analysis include power-line geometry and separation, size and type of shielding conductors, intervals between grounding and bonding points, quality of grounds and bonds, and degradation of sheath continuity. The presence of such devices as drainage reactors and neutralizing transformers can also be accounted for. Since this network model has basic importance for both the derivation of several specialized circuits in the next section, as well as computerized algorithms that allow detailed parametric studies, a brief description follows.

A useful simplification is contained within the network model at adjoining exposure segments as indicated in Fig. 3a. Note that the two segment admittances, Y_a^j and Y_b^j adjacent to location j , can be combined

with the constraint admittance, Y_c^j at location j , by simple matrix addition to form a total admittance, Y^j .

$$Y^j = Y_c^j + Y_b^j + Y_a^j. \quad (16)$$

With this reduction the total transverse current, I^j , which is "bled-off" the longitudinal current flow, constitutes the column vector addition of currents associated with the individual transverse admittance matrices.

$$I^j = I_c^j + I_b^j + I_a^j. \quad (17)$$

A knowledge of the node voltage, V^j , is sufficient to reconstruct the individual transverse current contributions via multiplication with the appropriate admittance matrix, as detailed in eqs. (11) and (15). Hence, the network analysis can now focus primarily upon determining V^j and $I^{j,j+1}$ for each location and segment. This network simplification is a direct result of having chosen the Norton equivalent circuit to characterize a general terminal constraint.

The foregoing simplification allows the overall network to be represented as shown in Fig. 3b. Assumed known in this model are the parameters for the Norton termination constraints, as well as the segment admittance and impedance matrices. Further discussion of these matrices can be found in Appendix A. An analytical solution for the network model will determine the unknown voltages and currents in terms of the remaining known circuit parameters. An algorithm that provides an efficient solution can be obtained by analyzing the composite circuit using ladder network techniques.⁵ A computer program centered around such an algorithm has been developed and utilized extensively to examine the parametric dependence of shielding.

III. SPECIALIZED CIRCUIT REPRESENTATIONS

Particular physical mechanisms associated with just certain conductors of a larger network will be the focal point of this discussion. The influence of the remaining parts of the network upon these chosen conductors can usually be characterized by dependent (i.e., controlled) sources. These sources contain information about the remaining circuitry and succinctly characterize its interaction with the chosen conductors. This approach makes it easier to understand the interaction with the remaining circuitry resulting from specific physical mechanisms. Moreover, it points the way to certain measurements that can be used to characterize a complex network. With these objectives in mind, this section develops specialized circuit models for coupling, shielding, and longitudinal-to-metallic conversion.

This approach furnishes only specialized characterizations of various physical mechanisms; it does not remove the overall system interde-

pendence among these mechanisms. Numerical values for the dependent sources, which represent the effects of the remaining network, may be partly influenced by parameters associated with the few chosen conductors. This interactive behavior can best be accounted for by an analysis of the total network. Such a solution may be simply formulated through the use of mutually interacting specialized circuits. These circuit representations serve as building blocks to construct the total network, and hence, its total interaction. This approach facilitates a direct analysis without the need of general matrix algebra formulations described in the previous section.

On the other hand, the interaction between the dependent sources and parameters of the chosen conductor(s) may sometimes be weak, or of "second-order" effect. In these instances simplifying approximations are appropriate, and quite limited measurements may suffice to characterize specific physical mechanisms. It is difficult, of course, to know when such approximations are valid, short of either actually performing the complete analysis or collecting extensive measurement data. In simplifying approximations, practical experience and/or intuition gained from prior analyses should be of value in establishing sound engineering judgment.

3.1 General coupling model

To simplify the discussion, a single conductor within an exposure segment can be selected for examining the longitudinal and transverse coupling to the remaining conductors within the segment. Let the chosen conductor be labeled i to denote any one of the several conductors numbered 1 through M within the segment. Moreover, consider the segment that connects arbitrary locations j and $j + 1$.

The longitudinal impedance type of coupling within segment $j, j + 1$ is characterized by matrix eq. (10). In its explicit form, this equation reads

$$\begin{bmatrix} V_1^j \\ V_2^j \\ \vdots \\ V_i^j \\ \vdots \\ V_M^j \end{bmatrix} - \begin{bmatrix} V_1^{j+1} \\ V_2^{j+1} \\ \vdots \\ V_i^{j+1} \\ \vdots \\ V_M^{j+1} \end{bmatrix} = \begin{bmatrix} Z_{11} & Z_{12} & \cdots & Z_{1i} & \cdots & Z_{1M} \\ Z_{21} & Z_{22} & \cdots & Z_{2i} & \cdots & Z_{2M} \\ \vdots & \vdots & & \vdots & & \vdots \\ \vdots & \vdots & & \vdots & & \vdots \\ Z_{i1} & Z_{i2} & \cdots & Z_{ii} & \cdots & Z_{iM} \\ \vdots & \vdots & & \vdots & & \vdots \\ \vdots & \vdots & & \vdots & & \vdots \\ Z_{M1} & Z_{M2} & \cdots & Z_{Mi} & \cdots & Z_{MM} \end{bmatrix} \begin{bmatrix} I_1 \\ I_2 \\ \vdots \\ I_i \\ \vdots \\ I_M \end{bmatrix} \quad (18)$$

The superscript notation has been omitted from the elements of $Z^{j,j+1}$ and $I^{j,j+1}$, since only one segment is under discussion. The difference

in voltage to remote ground between locations j and $j + 1$ for the i th conductor is given by multiplying the i th row of matrix $Z^{j,j+1}$ with column vector $I^{j,j+1}$:

$$V_i^j - V_i^{j+1} = Z_{i1}I_1 + Z_{i2}I_2 + \dots + Z_{ii}I_i + \dots + Z_{iM}I_M. \quad (19)$$

This equation for longitudinal voltage drop is made up of two kinds of terms.

(i) It is easy to recognize the voltage drop due to the self-impedance of conductor i as $Z_{ii}I_i$.

(ii) There are several mutual impedance terms, each of which accounts for longitudinal voltage induced in conductor i because of current flowing in some other conductor, e.g., k , as $Z_{ik}I_k$.

Hence, rewriting eq. (19) to keep these terms separate gives

$$V_i^j - V_i^{j+1} = Z_{ii}I_i + V_{si}, \quad (20a)$$

where

$$V_{si} \equiv \sum_{\substack{k=1 \\ (k \neq i)}}^M Z_{ik}I_k. \quad (20b)$$

The summation term above accounts for all effects associated with longitudinal coupling of the remaining conductors within the segment. When these conductors are relatively close, the mutual impedances, Z_{ik} , consist dominantly of positive reactance, and the coupling is referred to as inductive. For conductors having large spacing, the Z_{ik} parameters are both frequency-independent and dominantly resistive, which constitutes one form of dissipative coupling. The numerical dependence of Z_{ik} upon conductor spacing, frequency, and earth composition is more fully described elsewhere.⁶ What is important here is that these Z_{ik} parameters quantify both inductive coupling and resistive coupling.

In a comparable manner, the transverse admittance type of coupling within segment $j, j + 1$ is characterized by matrix eqs. (11a) and (11b). With the aid of eq. (12), the explicit form of eq. (11a) reads

$$\begin{bmatrix} I_{a1}^j \\ I_{a2}^j \\ \cdot \\ \cdot \\ I_{ai}^j \\ \cdot \\ \cdot \\ I_{aM}^j \end{bmatrix} = \frac{1}{2} \begin{bmatrix} Y_{11} & Y_{12} & \dots & Y_{1i} & \dots & Y_{1M} \\ Y_{21} & Y_{22} & \dots & Y_{2i} & \dots & Y_{2M} \\ \cdot & \cdot & & \cdot & & \cdot \\ \cdot & \cdot & & \cdot & & \cdot \\ \cdot & \cdot & & \cdot & & \cdot \\ Y_{i1} & Y_{i2} & \dots & Y_{ii} & \dots & Y_{iM} \\ \cdot & \cdot & & \cdot & & \cdot \\ \cdot & \cdot & & \cdot & & \cdot \\ \cdot & \cdot & & \cdot & & \cdot \\ Y_{M1} & Y_{M2} & \dots & Y_{Mi} & \dots & Y_{MM} \end{bmatrix} \begin{bmatrix} V_1^j \\ V_2^j \\ \cdot \\ \cdot \\ V_i^j \\ \cdot \\ \cdot \\ V_M^j \end{bmatrix}. \quad (21)$$

The superscript notation has again been omitted from the elements of $Y^{j,j+1}$, but must be retained for the column vectors I_a^j and V^j to distinguish between eqs. (11a) and (11b). The transverse current, I_{ai}^j , which flows after location j from the i th conductor, is obtained by multiplying the i th row of matrix Y_a^j with column vector V^j :

$$I_{ai}^j = 1/2(Y_{i1}V_1^j + Y_{i2}V_2^j + \dots + Y_{ii}V_i^j + \dots + Y_{iM}V_M^j). \quad (22)$$

This equation for transverse current flow is composed of two kinds of terms.

(i) The current flow due to the self-admittance of conductor i for the half of the segment closest to location j is identified as $(1/2)Y_{ii}V_i^j$.

(ii) Each of several mutual admittance terms accounts for the transverse current flow induced in conductor i caused by voltage on some other conductor, e.g., k , as $(1/2)Y_{ik}V_k^j$.

Rewriting eq. (22) to keep these terms separate gives

$$I_{ai}^j = 1/2Y_{ii}V_i^j - 1/2I_{si}^j, \quad (23a)$$

where

$$I_{si}^j \equiv - \sum_{\substack{k=1 \\ (k \neq i)}}^M Y_{ik}V_k^j. \quad (23b)$$

The choice of a negative sign with the summation is partially motivated by the fact that Y_{ik} is generally negative. A completely analogous development may be pursued starting with eq. (11b). Equation (12) is again used to obtain the admittance matrix for the half of the segment occurring before location $j + 1$. Separating out the two types of contributors to transverse current flow produces

$$I_{bi}^{j+1} = 1/2Y_{ii}V_i^{j+1} - 1/2I_{si}^{j+1}, \quad (24a)$$

where

$$I_{si}^{j+1} \equiv - \sum_{\substack{k=1 \\ (k \neq i)}}^M Y_{ik}V_k^{j+1}. \quad (24b)$$

The summation terms of eqs. (23b) and (24b) account for all effects associated with transverse coupling of the remaining conductors within the segment. When all the conductors are above ground, the mutual admittances Y_{ik} consist of appropriately signed susceptance, and the coupling is referred to as capacitive. For buried conductors having direct contact with the soil, the Y_{ik} parameters are both frequency-independent and dominantly conductive, which constitutes a second form of dissipative coupling. In actual buried installations, some conductors may be in direct contact with the soil, while others are insulated with dielectric

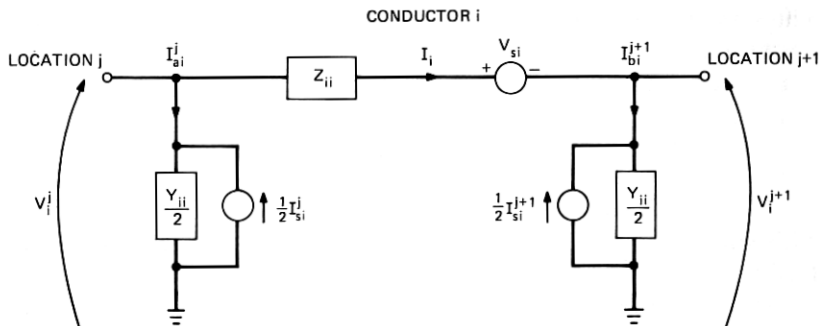

Fig. 4—Inductive, capacitive, and dissipative coupling model for i th conductor.

coatings. Hence, the Y_{ik} transverse admittance parameters quantify capacitive coupling and conductive coupling, both of which may occur simultaneously within a single exposure segment.

A general coupling model can now be obtained based upon the foregoing development. All pertinent coupling mechanisms are contained within eqs. (20), (23), and (24), and an equivalent circuit based upon these equations will portray all the relevant physical concepts. Such a circuit is evolved in the following manner.

The summation terms appearing in eqs. (20b), (23b), and (24b) may be modeled as dependent sources, in accordance with the substitution (or compensation) theorem of circuit theory.⁷ In particular, the induced longitudinal voltage term of eq. (20b) is modeled by an ideal dependent voltage source. This voltage source is termed ideal because it contains zero internal impedance. Moreover, it is dependent because its voltage value is determined by currents that exist on the other conductors within the segment, precisely in accord with eq. (20b). On the other hand, the compensation theorem permits modeling the induced transverse current terms of eqs. (23b) and (24b) by ideal dependent current sources. These current sources are termed ideal because they contain zero internal admittance (i.e., infinite impedance). Moreover, they are dependent because their current values are determined by voltages that exist on the other conductors within the segment, precisely in accord with eqs. (23b) and (24b).

Having ascribed dependent sources to account for the summation terms, eqs. (20a), (23a), and (24a) lead directly to the general coupling model shown in Fig. 4. This model applies to each single conductor within a segment; i.e., $i = 1, \dots, M$. Two conditions must be fulfilled for this equivalent circuit to constitute a valid coupling model.

(i) The equivalent circuit when subjected to standard circuit analysis techniques must yield precisely eqs. (20a), (23a), and (24a), since these equations characterize the pertinent coupling mechanisms.

(ii) The circuit analysis techniques must yield *only* these equations, i.e., no extraneous information may be falsely implied. This second requirement is quite important if the model is to avoid artifacts suggesting physical behavior that is not actually present.

Careful reflection should reveal that both these conditions have been satisfied in the illustrated coupling model. Hence, this equivalent circuit can be relied upon to furnish physical insight regarding the detailed interactions of all coupling mechanisms.

3.2 Various shielding models

With a reliable circuit model for coupling as a foundation, it is easy to evolve circuit models that describe various forms of shielding. In a rather fundamental way, shielding is nothing more than a wise utilization of available coupling mechanisms. These mechanisms are appropriately constrained to minimize an undesired signal that could contribute to interference. For instance, a low-impedance shunting path (such as a ground on an aerial cable sheath) is commonly used as a constraint upon capacitive coupling. Such a low-impedance terminal constraint serves to decrease the voltage that is supplied to an inherently high-impedance capacitive coupling mechanism and thereby renders the capacitive coupling mechanism ineffective. This type of shielding requires only one low-impedance shunting path and may be correctly termed electric shielding. (Historically, the unfortunate misnomer of "electrostatic" shielding has been used to describe electric shielding.) A second type of shielding requires at least two low-impedance shunting paths. These constraints allow a "shielding current" to flow which, in turn, induces a "shielding voltage" via magnetic induction. Owing to its enormous practical importance, this magnetic (or inductive) type of shielding will be emphasized in the following circuit representations.

The simplest form of inductive shielding is illustrated by the classical shielding model shown in Fig. 5. An understanding of the basic shielding phenomenon will be evident from a straightforward analysis of this simple circuit. However, a derivation of this circuit representation is first necessary to make clear its inherent limitations as caused by various simplifying assumptions.

Consider an exposure segment in which attention is focused upon two individual conductors: one conductor that is to be shielded and a second conductor that will furnish the inductive shielding. The coupling of each conductor to all remaining conductors within the segment is obtained from the inductive coupling model of Fig. 4. To apply this model to the shield (conductor 2), the admittances to ground $Y_{22}/2$ are taken to be zero, since they are shunted by the (assumed) low-resistance grounding terminations R_a and R_b . Moreover, the dependent current sources

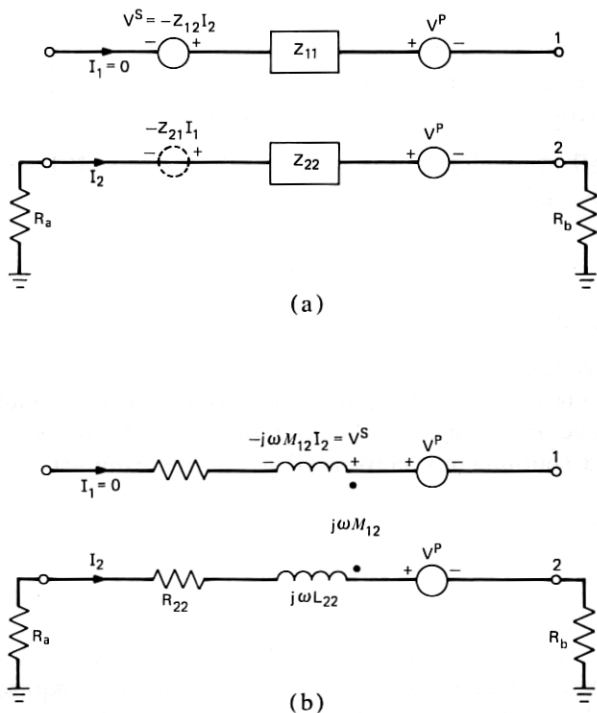

Fig. 5—Classical inductive shielding model. (a) Dependent-source circuit. (b) Complex transformer circuit.

$(1/2)I_{s2}$ are absent since transverse coupling is assumed negligible. Similarly, the coupling model for the shielded wire (conductor 1) also has zero admittances. This is in anticipation of a terminating impedance to ground that is located external to the segment and is low in relation to the impedance of the distributed capacitance of the conductors. By so suppressing extraneous detail wherever possible, it is easy to obtain a clear representation of the inductive shielding mechanism. In fact, no additional complication arises if the shielded wire is actually a twisted pair. In this event, the parameters for conductor 1 are simply replaced by those in the longitudinal circuit of Fig. 6a, which is developed in the next section.

The dependent voltage source within each coupling model is now decomposed. Recall that these voltage sources are determined by eq. (20b) with i given the values of 1 and 2. Those contributions to the voltage sources which arise from conductors 1 and 2 are first separated out as

$$V_{s1} = Z_{12}I_2 + \sum_{k=3}^M Z_{1k}I_k \quad (25a)$$

and

$$V_{s2} = Z_{21}I_1 + \sum_{k=3}^M Z_{2k}I_k. \quad (25b)$$

The summation terms account for coupling to all remaining conductors within the segment. If conductors 1 and 2 are physically near each other in comparison to the distance from each remaining current-carrying conductor, then $Z_{1k} \simeq Z_{2k}$, $k = 3, \dots, M$, as an examination of the appropriate mutual impedance equations will verify. In other words, the coupling to conductors 1 and 2 from each "outside" conductor becomes essentially identical. Under this condition, the summation terms in eqs. (25a) and (25b) are practically equal, and their contribution to the induced voltage within each conductor is the primary voltage, V^p :

$$\sum_{k=3}^M Z_{1k}I_k \simeq V^p \simeq \sum_{k=3}^M Z_{2k}I_k. \quad (26)$$

Although primary voltage is dependent upon the currents, I_k , ($k = 3, \dots, M$) which flow elsewhere within the segment, these currents are usually assumed to be unaffected by the presence of the shield, conductor 2. Hence, the V^p appearing in conductors 1 and 2 of Fig. 5 is often taken to be independent, or fixed, just as with a true applied source.

The remaining term in both eqs. (25a) and (25b) accounts for interaction between the shielding and shielded conductor. Consider the first term in eq. (25a) which is the voltage induced into the shielded conductor as a result of current flow in the shielding circuit formed by conductor 2. Since I_2 can be substantially 180 degrees out of phase from its assumed reference direction, this first term is rewritten as

$$Z_{12}I_2 = -[Z_{12}(-I_2)] \quad (27a)$$

$$\equiv -V^s, \quad (27b)$$

where the expression inside brackets is the shielding voltage, V^s . Shielding voltage as defined will often be of similar phase angle to V^p (owing to the negative sign within the brackets), and appears in the circuit representation of Fig. 5a as an opposing voltage source (owing to the second negative sign outside the brackets). It will be convenient to view the difference between the primary and shielding voltage sources as a remnant voltage, V^r . Hence,

$$V^r = V^p - V^s \quad (28)$$

is a useful measure of the shielding mechanism's effectiveness since, by eqs. (25a), (26), and (27), V^r is simply the total induced longitudinal voltage in the presence of shielding. This induced voltage is the driving

mechanism for longitudinal current flow in the shielded circuit and, consequently, for the accompanying longitudinal-to-metallic conversion process. The longitudinal current flow is usually small, however, in comparison to that in the shielding circuit, since the shielded circuit termination impedances are generally large compared to R_a and R_b . Hence, it is assumed that $I_1 = 0$ for purposes of the classical shielding model. This idealization allows the first term in eq. (25b) to be discarded, although its would-be presence is indicated in Fig. 5a by a "dashed-in" dependent voltage source.

By way of summarizing the physical mechanisms contained in the dependent source circuit of Fig. 5a, a simple calculation of shielding effectiveness will be carried out utilizing this classical shielding model. A measure of shielding effectiveness is the shield factor, η , defined as remnant voltage normalized to the exciting primary voltage

$$\eta \equiv \frac{V^r}{V^p} \quad (29a)$$

or

$$\eta = 1 - \frac{V^s}{V^p}, \quad (29b)$$

where the last relation follows from eq. (28). The shielding voltage depends upon longitudinal mutual impedance and shielding current as

$$V^s = Z_{12}(-I_2). \quad (30)$$

The latter quantity obtains from the shielding conductor loop equation

$$-I_2 = \frac{V^p}{Z_{22} + R_T}, \quad (31a)$$

where

$$R_T \equiv R_a + R_b. \quad (31b)$$

The amplitude and phase of the shielding current (and thereby the shielding voltage) is fundamentally dependent upon both longitudinal self-impedance and total termination resistance. Utilizing the above relations with the definition of eq. (29) yields the shield factor as

$$\eta = 1 - \frac{Z_{12}}{Z_{22} + R_T}. \quad (32)$$

Thus, the circuit representation leads quite directly to a simple expression for shielding effectiveness.

It is sometimes enlightening to visualize the inductive shielding mechanism in the context of a single-turn transformer. The circuit

formed by the shielding conductor and its earth-return path is viewed as one side of a transformer. The shielded conductor is viewed as an open-circuited secondary winding. A primary field is presumed to excite both windings, owing to its associated magnetic flux cutting both circuits equally. The resultant current flow in the primary winding then couples a shielding voltage into the secondary winding as a result of mutual inductance between the windings. These notions have been highlighted in the alternate shielding model shown in Fig. 5b.

The validity of the circuit representation in Fig. 5b rests upon its direct equivalence to that of Fig. 5a. Basically, the longitudinal coupling as characterized by dependent sources in Fig. 5a has been alternatively characterized as a complex-valued mutual inductance, with an appropriate transformer dot convention, in Fig. 5b. A conceptual generalization is required here in that the new mutual inductance must now represent energy dissipation as well as energy storage. That is, both the resistive and reactive parts of longitudinal mutual impedance are to be characterized by a mutual inductance term,

$$Z_{12} = (R_{12} + j\omega L_{12}) \equiv j\omega \mathcal{M}_{12}. \quad (33)$$

Hence, this new mutual term must assume a complex value given by

$$\mathcal{M}_{12} = \left(L_{12} + \frac{1}{j\omega} R_{12} \right). \quad (34)$$

It turns out for close conductor spacings that \mathcal{M}_{12} is dominantly real-valued (about 90 percent) as given via L_{12} , and the remaining imaginary term, $-jR_{12}/\omega$, characterizes dissipative coupling associated with the earth's nonzero resistivity. Although for most practical conductor spacings the coupling mechanism itself remains dominantly inductive, the phase relationship between V^s and V^p , and thereby the shielding, can be significantly affected by R_{12} .

3.3 Longitudinal-to-metallic conversion model

The general analytical model and all subsequent models described so far have been developed with the earth-return reference convention for voltage and current variables. This choice of reference convention was motivated primarily from the standpoint of consistency, such that various segments and termination constraints could be systematically cascaded to facilitate easy computer evaluation. Sometimes physical insight into a particular aspect of the overall problem can best be enhanced by adapting voltage and current variables which have a reference convention relating more directly to actual operating conditions. For instance, the effects of unbalanced operation in telephone circuits (which are intended to operate in basically a balanced circuit mode) are most

easily understood when analyzed as a so-called longitudinal and metallic circuit.

The relationship between the earth-return reference convention and the longitudinal and metallic reference convention is covered in detail in Appendix B. This relationship constitutes a change in variables, or a transformation, when stated in mathematical terms. This change further requires an appropriate modification of the previous circuit relations. The transformed equations, also detailed in the appendix, basically relate impedance and admittance quantities as used in a longitudinal or metallic circuit back to those appropriate to an earth-return circuit. The nomenclature and definitions introduced in Appendix B will be utilized in the following development.

To focus attention upon the electrical behavior of conductors 1 and 2 utilizing longitudinal and metallic reference conventions, the transformed circuit relations will be mathematically "partitioned." As in the specialized models already developed, one portion of the matrix equations remains unaltered, and the influence of other portions are lumped together into a single dependent term. This allows specialized circuit models for the first two conductors to be derived, in which the effects of all other conductors 3 through M are characterized as dependent voltage and current sources. From eq. (48) in Appendix B, the longitudinal interaction involving conductors 1 and 2 is given by

$$\begin{bmatrix} V_m^j \\ V_\ell^j \end{bmatrix} - \begin{bmatrix} V_m^{j+1} \\ V_\ell^{j+1} \end{bmatrix} = \begin{bmatrix} Z_m & 1/2\Delta Z \\ 1/2\Delta Z & Z_\ell \end{bmatrix} \begin{bmatrix} I_m \\ I_\ell \end{bmatrix} + \begin{bmatrix} V_{om} \\ V_{o\ell} \end{bmatrix}. \quad (35)$$

Here, the voltage contribution due to other conductors within the segment is denoted as

$$V_{om} \equiv \sum_{k=3}^M (Z_{1k} - Z_{2k})I_k \quad (36a)$$

for the metallic component, whereas for the longitudinal component,

$$V_{o\ell} \equiv \sum_{k=3}^M 1/2(Z_{1k} + Z_{2k})I_k. \quad (36b)$$

Hence, excitation of the longitudinal mode depends upon the average longitudinal mutual impedance between the pair conductors (1 and 2), and each of the others ($k = 3, \dots, M$). On the other hand, excitation of the metallic mode depends upon the difference in mutual impedances, as based upon the earth-return reference convention. This difference is typically minimized by twisting the pair conductors, causing them to effectively occupy the same position in relation to the other conductors. The transverse interaction, which corresponds to eq. (11), follows using

eq. (49) as

$$\begin{bmatrix} I_{am}^j \\ I_{a\ell}^j \end{bmatrix} = \frac{1}{2} \begin{bmatrix} Y_m & 1/2\Delta Y \\ 1/2\Delta Y & Y_\ell \end{bmatrix} \begin{bmatrix} V_m^j \\ V_\ell^j \end{bmatrix} - \frac{1}{2} \begin{bmatrix} I_{om}^j \\ I_{o\ell}^j \end{bmatrix}. \quad (37a)$$

The transverse current flow due to other conductors within the segment is given by

$$I_{om}^j \equiv - \sum_{k=3}^M 1/2(Y_{1k} - Y_{2k})V_k^j \quad (38a)$$

and

$$I_{o\ell}^j \equiv - \sum_{k=3}^M (Y_{1k} + Y_{2k})V_k^j. \quad (38b)$$

As in eq. (36), excitation of the longitudinal mode depends upon a sum of transverse mutual admittances, whereas excitation of the metallic mode depends upon a difference of terms characterizing coupling to other conductors. The seemingly illogical appearance or omission of a $1/2$ multiplicative factor is just a peculiarity of the longitudinal and metallic reference convention stated in eq. (43), Appendix B. A second eq., (37b) (not given), is obtained by replacing j with $j + 1$ and the subscript a with b . All the physical phenomena between locations j and $j + 1$ is encompassed within eqs. (35) and (37). If V_3, \dots, V_M and I_3, \dots, I_M are assumed known, either by previous analytical solution or by direct measurement, the above equations yield the response for conductors 1 and 2.

Physical insight is gained by constructing equivalent circuit models whose behavior is controlled by eqs. (35) and (37). It is convenient to derive two specialized circuit models: one to characterize the metallic variables and another for the associated longitudinal variables. Consolidating similar variables from eqs. (35) and (37) by simple rearrangement yields the pairs

$$\begin{aligned} V_m^j - V_m^{j+1} &= Z_m I_m + V_{sm} \\ I_{am}^j &= 1/2 Y_m V_m^j - 1/2 I_{sm}^j \\ I_{bm}^{j+1} &= 1/2 Y_m V_m^{j+1} - 1/2 I_{sm}^{j+1} \end{aligned} \quad (39)$$

and

$$\begin{aligned} V_\ell^j - V_\ell^{j+1} &= Z_\ell I_\ell + V_{s\ell} \\ I_{a\ell}^j &= 1/2 Y_\ell V_\ell^j - 1/2 I_{s\ell}^j \\ I_{b\ell}^{j+1} &= 1/2 Y_\ell V_\ell^{j+1} - 1/2 I_{s\ell}^{j+1}, \end{aligned} \quad (40)$$

where the new subscript s denotes source. Two terms are contained in

each dependent voltage source:

$$\begin{aligned}
 V_{sm} &\equiv 1/2\Delta ZI_{\ell} + V_{om} \\
 &= 1/2(Z_{11} - Z_{22})I_{\ell} + \sum_{k=3}^M (Z_{1k} - Z_{2k})I_k
 \end{aligned} \tag{41a}$$

and

$$\begin{aligned}
 V_{s\ell} &\equiv 1/2\Delta ZI_m + V_{o\ell} \\
 &= 1/2(Z_{11} - Z_{22})I_m + \sum_{k=3}^M 1/2(Z_{1k} + Z_{2k})I_k.
 \end{aligned} \tag{41b}$$

The first term in each source represents mode coupling due to impedance unbalance and the second term represents the coupling to other conductors as defined in eq. (36). Similarly, the dependent current sources become

$$\begin{aligned}
 I_{sm}^j &\equiv -1/2\Delta YV_{\ell}^j + I_{om}^j \\
 &= -1/2(Y_{11} - Y_{22})V_{\ell}^j - \sum_{k=3}^M 1/2(Y_{1k} - Y_{2k})V_k^j
 \end{aligned} \tag{42a}$$

and

$$\begin{aligned}
 I_{s\ell}^j &\equiv -1/2\Delta YV_m^j + I_{o\ell}^j \\
 &= -1/2(Y_{11} - Y_{22})V_m^j - \sum_{k=3}^M (Y_{1k} + Y_{2k})V_k^j.
 \end{aligned} \tag{42b}$$

Here the first term in each source represents mode coupling due to admittance unbalance and the second term represents coupling to other conductors as defined in eq. (38). A corresponding set of current sources is obtained from eq. (37b) simply by replacing j with $j + 1$ in the above. The metallic circuit eqs. (39) can now be characterized by the equivalent circuit in Fig. 6b, and the associated longitudinal circuit eqs. (40) similarly in Fig. 6a.

It should be noted that in general these two circuits are "coupled" via the dependent sources; that is, the dependent voltage and current sources for the metallic circuit require knowledge of V_{ℓ} and I_{ℓ} from the longitudinal circuit, and vice versa. In certain situations, however, the coupling parameters are such that the excitation from a dependent source becomes independent of the other equivalent circuit. In this situation the metallic and longitudinal segment models are said to be "decoupled"; i.e., they function independently in the absence of termination unbalances. Furthermore, it may even occur that mutual coupling parameters to the partitioned conductors 3, \dots , M are such as to suppress excitation of a dependent source. To illustrate these points, consider the case of

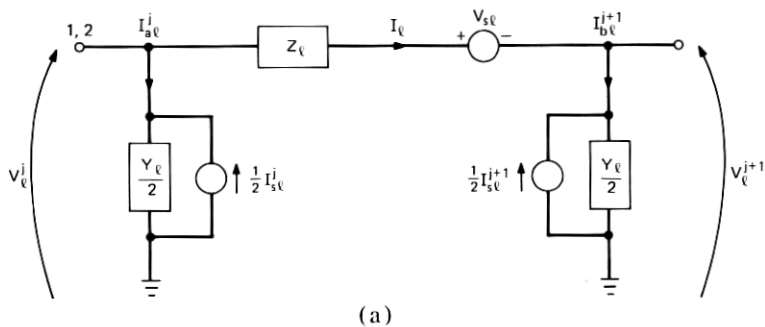

(a)

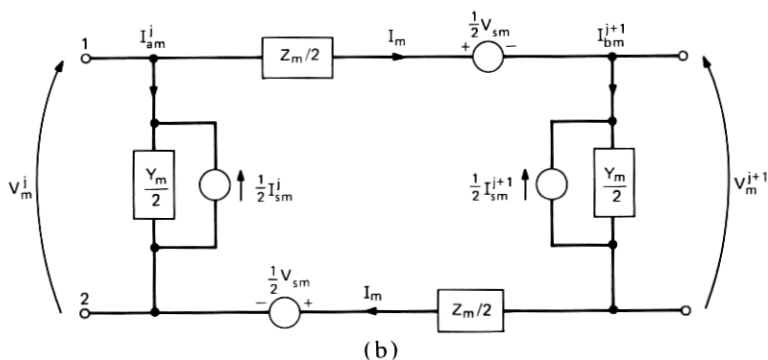

(b)

Fig. 6—Longitudinal-to-metallic conversion model. (a) Segment of a longitudinal circuit. (b) Segment of a metallic circuit.

a twisted pair with small admittance and impedance unbalances enclosed within a conducting sheath. The twisting results in $Z_{22} \approx Z_{11}$, i.e., small impedance unbalance, and generally $|I_m| \ll |I_k|$ for some $k = 3, \dots, M$. This allows the first term in eq. (41b) to be dropped since, as the product of two small quantities, it is negligible compared to the summation term. Similar reasoning applies to the first term in eq. (42b), which also can be dropped since the admittance unbalance is assumed small. Let us assume for illustrative purposes the remaining pair conductors are bonded to the sheath, and denote this aggregate collection as conductor 3. Then, within the summation, terms Y_{1k} and Y_{2k} are zero for $k > 3$, owing to capacitive shielding furnished by the enclosing sheath (conductor 3). Hence, the current sources can be removed from the longitudinal circuit model provided the sheath conductor is at ground potential, i.e., $V_3 = 0$, while the voltage source becomes dependent only upon current flow in conductors 3 through M . This allows the longitudinal equivalent circuit to be solved first, subject only to various terminal

constraints (i.e., termination impedances). The results are then applied to the metallic equivalent circuit to assess longitudinal-to-metallic conversion, arising from coupling parameter and termination impedance unbalances. This simplified longitudinal circuit and the decoupled metallic circuit can be explored quite effectively to illustrate the longitudinal-to-metallic conversion process.

IV. SUMMARY

A systematic approach has been described for evolving lumped-element circuit models appropriate to low frequency interference analysis. By straightforward computer implementation one can reliably assess the intricate interaction of various physical mechanisms which occur in real life interference situations. Care has been taken to follow a strictly deductive approach in the modeling procedure. This ensures an accurate characterization of all relevant physical mechanisms, while preventing the occurrence of any extraneous modeling artifacts.

The specialized circuit representations have highlighted the individual effects of coupling, shielding, and longitudinal-to-metallic conversion on telephone cable facilities. Their development systematically identifies all underlying assumptions and thereby offers clarification on the conditions which must be satisfied to permit confident reliance on these models. Three distinct types of coupling are identified: inductive, capacitive, and dissipative (the latter taking both longitudinal and transverse forms). Electric and magnetic types of shielding have been motivated as just wise utilizations of available coupling mechanisms. Finally, the longitudinal-to-metallic conversion model is unique in its ability to concisely characterize an arbitrary multi-conductor power and telephone environment.

A carefully prepared glossary has been included as Appendix D. Particular attention is given to resolving jargonistic ambiguities by referring back to fundamental principles. It is the author's experience that unnecessary confusion generally results from the use of "loose" terminology. In instances of conflicting historical usage, the present analytical framework is relied upon to furnish definitiveness.

V. ACKNOWLEDGMENTS

The author wishes to acknowledge many enlightening discussions, particularly concerning the glossary, with colleagues W. A. Reenstra, C. W. Anderson, D. V. Batorsky, G. A. DeBalko, G. H. Estes, D. N. Heirman, P. M. Lapsa, and D. W. McLellan, along with S. W. Guzik, formerly from the Electrical Coordination and Protection Group of the AT&T Company.

Perspective on Admittance Matrices

Transverse coupling can occur either within an individual exposure segment or from mutual interaction within a terminal constraint, as indicated by the model for cascaded segments shown in Fig. 3. In all but a few actual cases, the terminal constraint phenomena are generally dominant by manifesting high admittances, Y_c^j , compared to those for distributed effects in individual segments, Y_a^j and Y_b^j . In these situations, it is acceptable to assume Y_a^j and Y_b^j are zero for computational purposes. Basically, this implies that within a segment the radial flow of displacement current (associated with distributed capacitance) and of conduction current (associated with leakage conductance) are both negligible, either in themselves or with respect to current entering conductor nodes of the terminal constraint at location j . These conditions are typically met for nodes to which practical grounding configurations have been applied. However, for nodes at which grounding is either relatively poor or intentionally absent, all contributing admittances need to be retained. For instance, the conductance to ground and to other conductors may require consideration with direct burial noninsulated cable, such as concentric neutral power line. Conductance values can be obtained, either by means of direct measurement or by existing analytical techniques.⁶ Moreover, the susceptance portion of Y_a^j and Y_b^j arising from self-capacitance and mutual capacitance effects may be important under either very high voltage or exceptionally low current situations. The former situation can exist in the proximity of EHV power transmission systems.^{8,9} The latter low-current situation manifests itself in affecting actual open-circuit voltage-to-ground (or sheath) on pairs within long segments of telephone cable.

Treating terminal constraint phenomena in the mathematical framework of admittance parameters is somewhat arbitrary, since a Thevenin representation might also have been chosen to characterize a general terminal constraint in terms of impedance parameters. When the terminal constraints are simply independent grounds, it is logical to consider the associated ground potential raise (GPR) a longitudinal impedance phenomenon as did Sunde,⁶ since its primary effect is to restrict longitudinal current flow. On the other hand, when closely spaced nonindependent grounds interact strongly through mutual GPR effects, it is reasonable to view longitudinal currents as being partially excited through a localized transverse interaction with adjacent grounds acting as primary sources. Aside from whichever type of excitation actually prevails, it is computationally expedient to model mutual GPR interaction as a transverse admittance phenomenon, primarily because of the

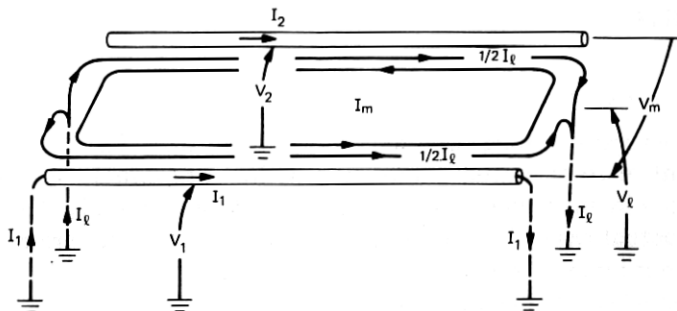

Fig. 7—Relationship of longitudinal and metallic variables to earth-return variables.

analytical simplification of combining parallel admittances through addition as illustrated in Fig. 3a.

APPENDIX B

Longitudinal and Metallic Reference Convention

A portion of the general analysis pertaining to multiconductor segments is modified by explicitly singling out two conductors for an alternate characterization in terms of the longitudinal and metallic reference convention. This "change of variables" necessitates that a transformation be applied to the basic circuit relations. The modified equations for use with this alternate reference convention are summarized below.

Let us identify conductors 1 and 2 for this new representation. (By appropriate choice of numbering, these two conductors might represent a twisted pair within a conducting sheath, or even more simply an open wire line. Alternatively, they could represent a phase and neutral conductor from a single-phase power system.) The basic approach is to define four new variables, V_m , V_l , I_m , I_l , in terms of the previous voltages-to-ground V_1, V_2 and earth-return currents I_1, I_2 as follows:

$$\begin{aligned}
 V_m &= V_1 - V_2 && \text{(metallic voltage),} \\
 V_l &= \frac{1}{2}(V_1 + V_2) && \text{(longitudinal voltage),} \\
 I_m &= \frac{1}{2}(I_1 - I_2) && \text{(metallic current),} \\
 I_l &= I_1 + I_2 && \text{(longitudinal current).} \quad (43)
 \end{aligned}$$

It may be helpful to note the last two current relations derive from

$$\begin{aligned}
 I_1 &= \frac{1}{2}I_l + I_m, \\
 I_2 &= \frac{1}{2}I_l - I_m. \quad (44)
 \end{aligned}$$

The relationships between old and new variables are illustrated in Fig. 7. These new longitudinal and metallic variables differ quite notably

from the previous earth-return variables in that they encompass effects occurring on two conductors. Consequently, all four new variables quantify effects that are "shared" between conductors 1 and 2 as they function together. (It is interesting to note that standard noise measuring sets automatically record V_ℓ and V_m .) In summary, the foregoing change of variables can be compactly represented by transformations T_v and T_i in the following matrix form

$$V_T \equiv \begin{bmatrix} V_m \\ V_\ell \\ \hline V_3 \\ \cdot \\ \cdot \\ \cdot \\ V_M \end{bmatrix} = \begin{bmatrix} 1 & -1 & 0 & | & \cdots & 0 \\ \hline 1/2 & 1/2 & 0 & | & \cdots & 0 \\ \hline 0 & 0 & 1 & | & \cdots & 0 \\ \cdot & \cdot & \cdot & | & \cdot & \cdot \\ \cdot & \cdot & \cdot & | & \cdot & \cdot \\ \cdot & \cdot & \cdot & | & \cdot & \cdot \\ 0 & 0 & 0 & | & \cdots & 1 \end{bmatrix} \begin{bmatrix} V_1 \\ V_2 \\ \hline V_3 \\ \cdot \\ \cdot \\ \cdot \\ V_M \end{bmatrix} \equiv [T_v]V \quad (45a)$$

and

$$I_T \equiv \begin{bmatrix} I_m \\ I_\ell \\ \hline I_3 \\ \cdot \\ \cdot \\ \cdot \\ I_M \end{bmatrix} = \begin{bmatrix} 1/2 & -1/2 & 0 & | & \cdots & 0 \\ \hline 1 & 1 & 0 & | & \cdots & 0 \\ \hline 0 & 0 & 1 & | & \cdots & 0 \\ \cdot & \cdot & \cdot & | & \cdot & \cdot \\ \cdot & \cdot & \cdot & | & \cdot & \cdot \\ \cdot & \cdot & \cdot & | & \cdot & \cdot \\ 0 & 0 & 0 & | & \cdots & 1 \end{bmatrix} \begin{bmatrix} I_1 \\ I_2 \\ \hline I_3 \\ \cdot \\ \cdot \\ \cdot \\ I_M \end{bmatrix} \equiv [T_i]I. \quad (45b)$$

The new transformed voltage and current column vectors are denoted as V_T and I_T , respectively. Moreover, for ease of examination dashed lines are used to partition each matrix equation into regions having a particular form. Within the transformation matrices, the upper left-hand corner represents eqs. (43), whereas the lower right-hand corner preserves the earth-return reference convention for conductors 3 through M .

Recall the transmission line eqs. (1) and (2) in their matrix form, such that they characterize the complete behavior within a multiconductor exposure segment. Interjecting the new transformed variables of eq. (45), the transmission line relations become

$$-\frac{dI_T}{dz} = [T_i \mathcal{Y} T_v^{-1}] V_T \equiv \mathcal{Y}_T V_T \quad (46)$$

and

$$-\frac{dV_T}{dz} = [T_v \mathcal{Z} T_i^{-1}] I_T \equiv \mathcal{Z}_T I_T, \quad (47)$$

where \mathcal{Y}_T and Z_T are the new transformed incremental admittance and impedance matrices, as obtained from the indicated matrix operations. On the basis of reasoning identical to that preceding eqs. (10) and (11), a corresponding set of circuit relations is evolved in terms of the transformed variables. In particular, eq. (10) becomes eq. (48) shown on page 1691, where the following notation has been introduced:

$$\begin{aligned} Z_m &\equiv Z_{11} + Z_{22} - 2Z_{12} && \text{(metallic circuit impedance),} \\ Z_\ell &\equiv 1/4 (Z_{11} + Z_{22} + 2Z_{12}) && \text{(longitudinal circuit impedance),} \\ \Delta Z &\equiv Z_{11} - Z_{22} && \text{(impedance unbalance).} \end{aligned}$$

Individual Z_{ik} values are the matrix elements of $Z_T^{j,j+1}$ defined in eq. (10). The superscripts on $Z_T^{j,j+1}$ and $I_T^{j,j+1}$, which identify the specific segment under consideration, have been omitted on the matrix and column vector elements in eq. (48) to minimize notational congestion. The transformed version of eqs. (11) follow simply upon noting eq. (49), shown on page 1691, where

$$\begin{aligned} Y_m &\equiv 1/4 (Y_{11} + Y_{22} - 2Y_{12}) && \text{(metallic circuit admittance),} \\ Y_\ell &\equiv Y_{11} + Y_{22} + 2Y_{12} && \text{(longitudinal circuit admittance),} \\ \Delta Y &\equiv Y_{11} - Y_{22} && \text{(admittance unbalance).} \end{aligned}$$

Both $Z_T^{j,j+1}$ and $Y_T^{j,j+1}$ are symmetric matrices since all $Z_{ik} = Z_{ki}$ and $Y_{ik} = Y_{ki}$ from reciprocity.

APPENDIX C

Circuit Model Frequency Restrictions

It is worthwhile from both an applicational and theoretical point of view to clarify the frequency range over which the equivalent circuit models are applicable. Recall that in starting from the transmission line eqs. (1) and (2), and going to the lumped-element circuit theory eqs. (10) and (11), an electrically short segment of the loop plant was specifically considered. The meaning of this earlier assumption is now examined in some detail.

Note the electrically short assumption is likewise implicit in arriving at the metallic and longitudinal circuit eqs. (39) and (40), to which the equivalent circuit models of Fig. 6 apply. The initial discussion will focus upon these two models and later be expanded to include all conductors within an exposure segment. Whereas these circuit models are exact characterizations of the lumped-element circuit equations, it is important to know how well they approximate the behavior associated with the original transmission line differential equations. Fortunately, this

$$\begin{bmatrix} V_m^j \\ V_\ell^j \\ V_3^j \\ V_4^j \\ \cdot \\ \cdot \\ \cdot \\ V_M^j \end{bmatrix} - \begin{bmatrix} V_m^{j+1} \\ V_\ell^{j+1} \\ V_3^{j+1} \\ V_4^{j+1} \\ \cdot \\ \cdot \\ \cdot \\ V_M^{j+1} \end{bmatrix} = \begin{bmatrix} Z_m & \frac{1}{2}\Delta Z & (Z_{13} - Z_{23}) & (Z_{14} - Z_{24}) & \dots \\ \frac{1}{2}\Delta Z & Z_\ell & \frac{1}{2}(Z_{13} + Z_{23}) & \frac{1}{2}(Z_{14} + Z_{24}) & \dots \\ (Z_{31} - Z_{32}) & \frac{1}{2}(Z_{31} + Z_{32}) & Z_{33} & Z_{34} & \dots Z_{3M} \\ (Z_{41} - Z_{42}) & \frac{1}{2}(Z_{41} + Z_{42}) & Z_{43} & Z_{44} & \cdot \\ \cdot & \cdot & \cdot & \cdot & \cdot \\ \cdot & \cdot & \cdot & \cdot & \cdot \\ \cdot & \cdot & \cdot & \cdot & \cdot \\ V_M^{j+1} & \cdot & Z_{M3} & \dots & Z_{MM} \end{bmatrix} \begin{bmatrix} I_m \\ I_\ell \\ I_3 \\ I_4 \\ \cdot \\ \cdot \\ \cdot \\ I_M \end{bmatrix} \quad (48)$$

$$Y_T^{j,i+1} \equiv y_T^{j,i+1} \Delta \ell = \begin{bmatrix} Y_m & \frac{1}{2}\Delta Y & \frac{1}{2}(Y_{13} - Y_{23}) & \frac{1}{2}(Y_{14} - Y_{24}) & \dots \\ \frac{1}{2}\Delta Y & Y_\ell & (Y_{13} + Y_{23}) & (Y_{14} + Y_{24}) & \dots \\ \frac{1}{2}(Y_{31} - Y_{32}) & (Y_{31} + Y_{32}) & Y_{33} & Y_{34} & \dots Y_{3M} \\ \frac{1}{2}(Y_{41} - Y_{42}) & (Y_{41} + Y_{42}) & Y_{43} & Y_{44} & \cdot \\ \cdot & \cdot & \cdot & \cdot & \cdot \\ \cdot & \cdot & \cdot & \cdot & \cdot \\ \cdot & \cdot & \cdot & \cdot & \cdot \\ Y_M^{j+1} & \cdot & Y_{M3} & \dots & Y_{MM} \end{bmatrix} \quad (49)$$

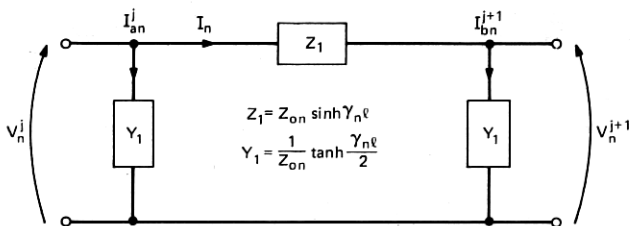

Fig. 8—Equivalent network for a general transmission line.

question is rather easily resolved, since an exact pi-network model is available for the general transmission line case.¹⁰ Specifically, the exact behavior of the terminal voltage and terminal current is characterized by the equivalent network shown in Fig. 8. The particular choice of voltage and current variables defines a form of "mode" which will be designated as n . Here, $n = \ell$ or m , for either the longitudinal or metallic type mode response of the transmission line differential equations. The characteristic impedance for mode n is defined by

$$Z_{on} \equiv \sqrt{\frac{Z_n}{Y_n}}, \quad (50)$$

and the all-important electrical length is

$$\gamma_n \ell \equiv \sqrt{Z_n Y_n}, \quad (51)$$

where the Z_ℓ, Z_m and Y_ℓ, Y_m were specified in Appendix B by eqs. (48) and (49), respectively, for a segment length of $\Delta \ell \equiv \ell$.

The general transmission line equivalent network of Fig. 8 reduces to the impedances and admittances within the circuit models of Fig. 6 for sufficiently small values of $\gamma_n \ell$. To see this, note that

$$\sinh \gamma_n \ell \rightarrow \gamma_n \ell \quad (52a)$$

and

$$\tanh \frac{\gamma_n \ell}{2} \rightarrow \frac{\gamma_n \ell}{2} \quad (52b)$$

for $|\gamma_n \ell| \ll 1$. Hence, for the series impedance branch of the pi-network,

$$Z_1 = Z_{on} \sinh \gamma_n \ell \rightarrow Z_{on} \gamma_n \ell = \sqrt{\frac{Z_n}{Y_n}} \sqrt{Z_n Y_n} = Z_n; \quad (53)$$

for the two shunt admittance elements,

$$Y_1 = \frac{1}{Z_{on}} \tanh \frac{\gamma_n \ell}{2} \rightarrow \frac{\gamma_n \ell}{2 Z_{on}} = \sqrt{Z_n Y_n} / 2 \sqrt{\frac{Z_n}{Y_n}} = \frac{Y_n}{2}, \quad (54)$$

where $n = \ell$ or m . The restriction $|\gamma_n \ell| \ll 1$ can be relaxed substantially without incurring appreciable error. For instance, with $|\gamma_n \ell| \leq 0.5$, the circuit elements of Fig. 6 will be within 5 percent of their true values as given by transmission line theory in Fig. 8. This condition serves as a practical guide in deciding the upper frequency limit for which just one segment of the longitudinal and metallic circuit models furnish reasonable accuracy.

A few observations of more general nature will now be made. The metallic and longitudinal variable equivalent circuits derived previously focus attention upon the circuit variables and parameters contained in the upper part of the partitioned eqs. (48) and (49). Dependent sources were utilized to account for the coupling to other conductors within the segment. One can similarly focus attention upon the lower part of the partitioned eqs. (48) and (49). In this case, each distinct conductor will have just a single earth-return equivalent circuit, corresponding to that shown in Fig. 4. Moreover, each conductor will give rise to one distinct mode n , wherein the impedance and admittance parameters of the transmission line solution and lumped-element circuit solution relate as $Z_n = Z_{nn}$, $Y_n = Y_{nn}$, $n = 3, \dots, M$. Hence, we see that every conductor contained in the segment has associated with it an electrical length, $\gamma_n \ell$, the largest of which will be denoted as $\gamma_N \ell$. Evidently a segment is electrically short, and thus characterizable by a correspondingly simple circuit model, whenever $|\gamma_N \ell|$ is sufficiently small in the sense discussed above. The presence of dependent sources does not alter this conclusion, since they too characterize only electrically short behavior. That is, the sources are composed of mutual admittance and mutual impedance terms, for which it can be shown that $|Y_{ik}| < |Y_{kk}|$ and $|Z_{ik}| < |Z_{kk}|$ for all k (or n) of interest. Hence, if the self-admittance and self-impedance terms, Y_{nn} and Z_{nn} , satisfy an electrically short criterion, so too must the mutual terms.

It should be stated that these modes and associated propagation constants, γ_n , are somewhat unorthodox; they differ from the customary "eigenmodes" of the M -conductor system. Eigenmodes are ordinarily defined⁴ from the n eigenvalue roots, γ_n^2 , of the matrix equation $|YZ - \gamma^2 U| = 0$, where U is a unity matrix. Each distinct root then constitutes two eigenmodes, $e^{\pm \gamma_n z}$, having the property that they can propagate independently without undergoing distortion. To the extent the largest $\gamma_N \equiv \max \gamma_n$ can be easily estimated without extensive numerical procedures, this more orthodox approach furnishes a completely rigorous method for testing a multiconductor segment of length ℓ to determine compliance with being electrically short. The values of γ_n associated with the eigenmode approach differ from those described above in accordance with the levels of mutual coupling, as characterized by the dependent sources in the circuit models of Figs. 4 and 6.

APPENDIX D

Glossary

Conduction Current	The current flow that is associated solely with the finite conductivity, σ , or resistivity, ρ , of a medium; e.g., the current flow through a resistance.
Conductive Coupling	The contribution to transverse coupling arising from Ohm's law and the flow of conduction current.
Controlled Sources	Current and voltage generators (sources) controlled by voltage and current signals, respectively. Since controlled sources are dependent on a control signal, they are often referred to as dependent sources.
Dependent Sources	See controlled sources.
Displacement Current	The current flow associated solely with the permittivity, ϵ , of a medium; e.g., the current flow through a capacitance.
Dissipative Coupling	A general term encompassing the physical mechanism of resistive or conductive coupling.
Earth-Return Reference Convention	A voltage variable whose reference potential is that of remote ground; a current variable whose return path is assumed to be through the ground.
Effective Mutual Impedance	The ratio of the total induced open-circuit voltage on the disturbed circuit to the disturbing power system phase current with the effects of all conductors taken into account.
Electric (or Capacitive) Coupling	The contribution to transverse coupling arising from Gauss' law of electric induction and the flow of displacement current.
Electromagnetic Coupling	A general term encompassing primarily electric and magnetic coupling and, in principle, dissipative coupling too.
External Impedance	The (total) longitudinal impedance less that contribution due to internal impedance.
Internal Impedance	The sum of the conductor resistance and internal reactance (from the magnetic field inside the conductor).

Longitudinal and Metallic Reference Convention	Voltage and current variables that are related to the earth-return reference convention as shown in eq. (43).
Longitudinal Circuit	A circuit utilizing longitudinal reference conventions for the voltage and current variables.
Longitudinal Coupling	The force exerted on a charge by an electric field in a longitudinal or axial direction of a conductor.
Longitudinal Current	The directed current flow along the axis of a conductor; this flow may be measured using either earth-return or longitudinal reference conventions.
Longitudinal Impedance	A quantitative measure of longitudinal coupling within a segment, accounting for both inductive and resistive types of coupling (dependent upon chosen reference convention).
Longitudinal Input Impedance	The Thevenin impedance looking into the longitudinal circuit formed by the wire pair and terminating impedances.
Longitudinal Voltage	The change in voltage occurring along the axis of a conductor; this change may be measured using either longitudinal or earth-return reference conventions. (Also the voltage variable in the longitudinal reference convention).
Magnetic (or Inductive) Coupling	The contribution to longitudinal coupling arising from Faraday's law of magnetic induction and the flow of conduction current.
Metallic Circuit	A circuit utilizing metallic reference conventions for the voltage and current variables.
Mutual Coupling	A transverse admittance or longitudinal impedance which relates the stimulus on one conductor to its response upon another conductor.
Phasor	A harmonically time-dependent complex number. Phasors are added, subtracted, multiplied, and divided in the same way as

	complex numbers. Often phasor additions are referred to as vector additions.
Power Line Balance	The relative absence of residual current at a particular frequency for a group of power line conductors; balance at one frequency, in general, does not imply balance at another (harmonic) frequency.
Power Line Balance Factor	The ratio of the sum of the phase current magnitudes divided by the residual current magnitude; this quantity or its logarithm is a figure of merit for the degree of balance of a power line at a particular frequency.
Primary Voltage	The voltage induced in the disturbed circuit by current in the disturbing circuit, in the absence of the intended shielding circuit.
Remnant Voltage	The voltage induced in the disturbed circuit by current in the disturbing circuit with the intended shielding circuit present.
Remote Ground Potential	The potential of a region several skin-depths into the earth immediately beneath some specified conductor location. This reference potential is usually assumed to equal zero.
Residual Current	The instantaneous or phasor sum of the conductor currents for a group of power line conductors; this current returns to the source through a path other than those conductors.
Resistive Coupling	The contribution to longitudinal coupling arising from Ohm's law and the flow of conduction current.
Self-Reaction	A transverse admittance or longitudinal impedance which relates the stimulus to its associated response upon the same conductor.
Shield Factor	The ratio of remnant voltage to primary voltage for a constant value of disturbing current; a measure of shielding effectiveness, i.e., the smaller the ratio or shield factor, the better the shield in reducing remnant voltage.
Skin Depth	The depth into a conductor at which the magnitude of the electromagnetic field is reduced to approximately $1/e$ of its surface value; its thickness is given in terms of resistivity, radian frequency, and permeability as $\delta = \sqrt{2\rho/\omega\mu}$.

Skin Effect	A phenomenon associated with time-varying fields which tends to concentrate currents toward the surface of conductors that are nearest to the field sources which produce the currents. The skin-depth is a measure of this effect.
Transverse Admittance	A quantitative measure of transverse coupling, accounting for both capacitive and conductive types of coupling (dependent upon chosen reference convention).
Transverse Coupling	The force exerted on a charge by an electric field in a direction transverse or perpendicular to the axis of a conductor.
Transverse Current	The outward current flow perpendicular to the axis of a conductor which accompanies a decrease in longitudinal current.

REFERENCES

1. P. I. Kuznetsov and R. L. Stratonovich, *The Propagation of Electromagnetic Waves in Multiconductor Transmission Lines*, Oxford, England: Pergamon Press, 1964.
2. J. R. Whinnery and S. Ramo, *Fields and Waves in Modern Radio*, New York: John Wiley & Sons, 1953, Chap. 6.
3. S. R. Seshadri, *Fundamentals of Transmission Lines and Electromagnetic Fields*, Reading, Mass.: Addison-Wesley, 1971.
4. C. R. Paul, "On Uniform Multimode Transmission Lines," *IEEE Trans. on Microwave Theory and Techniques*, *MTT-21*, No. 8 (Aug. 1973).
5. Franklin F. Kuo, *Network Analysis and Synthesis*, 2nd ed., New York: John Wiley & Sons, 1966.
6. Erling D. Sunde, *Earth Conduction Effects in Transmission Systems*, New York: Dover Publications, 1968.
7. E. J. Angelo, Jr., *Electronic Circuits*, New York: McGraw-Hill, 1964.
8. Eric T. B. Gross and M. Harry Hesse, "Electrostatically Induced Voltages Above High Voltage Lines," *Journal of the Franklin Institute*, 295, No. 2 (February 1973).
9. L. O. Berthold, Chrm., Working Group, et al., "Electrostatic Effects of Overhead Transmission Lines, Part II—Methods of Calculation," Paper 21 TP 645-PWR, IEEE Summer Meeting and International Symposium on High Power Testing, Portland, Oregon, July 18–23, 1971.
10. Walter C. Johnson, *Transmission Lines and Networks*, New York: McGraw-Hill, 1950.

