

Transaction Network, Telephones, and Terminals:

Transaction Stations

By W. E. BAKER, R. M. DUDONIS, and J. H. KEE

(Manuscript received June 6, 1978)

The Transaction station family includes the Transaction I and II telephones and the Transaction III terminal. This paper describes these sets. They are designed to provide access to data base systems via the switched network or, for Transaction III, the dedicated Transaction Network. The items discussed are overall telephone/terminal operation, hardware and software design, and data center interaction and protocol.

I. INTRODUCTION

The Transaction I and II telephones are designed to serve as user main station telephones and to automate the procedures of short message, inquiry/response systems when connected to a customer's computer center via the switched telecommunications network. These telephones have been employed in a broad range of financial applications including credit checking, check authorization, account inquiry, teller inquiry, and electronic funds transfer. Other industry applications include inventory control, process control, and personal identification systems.

The Transaction telephone transmits short computer inquiries as TOUCH-TONE® signals and receives responses returned as voice or data messages. It provides a means of reading information from plastic cards encoded with a magnetic stripe and a means of manual data entry. Instruction lamps guide the user through the transaction.

In general, information needed by the computer in these inquiries includes merchant identification, customer identification, and the nature and amount of the transaction. The merchant and dialing information is generally obtained from a dialing card, while the customer information is obtained from a customer card. The dialing card also contains control information for the Transaction telephone. Where cards are not avail-

able, these data can be entered manually. Discretionary data, such as a dollar amount or a transaction code, are always entered manually on the keyboard. For added security, an auxiliary manual entry pad may be added for entry of customer Personal Identification Numbers (PIN).

The Transaction II supports voice responses, keyed answer tone (KAT) responses, and frequency-shift keyed (FSK) responses. The Transaction I supports only voice and KAT responses.

The Transaction telephones also provide basic telephone service. Manual dialing is provided via a *TRIMLINE*[®] handset or the manual entry pad. The telephones can be used as automatic dialers by using appropriately encoded magnetic striped cards.

The Transaction III is also an inquiry/response terminal differing from its two predecessors in that it operates on dedicated exchange facilities on a polled basis. It was designed to interface to a customer's computer center via the data-only polled access facilities of the Transaction Network Service (TNS).

The operation of the Transaction III terminal by the user is basically the same as that of the dial sets. Information needed by the computer is normally entered via two magnetically encoded cards and a manual entry keyboard. Instead of a dialing card, the terminal employs an identification (ID) card which contains the Transaction Network (TN) address of the Customer Service Center (CSC). Other data on this card are option control information and merchant identification.

The Transaction III terminal communicates with the Transaction Network on an ordinary unconditioned 2-wire line at 1200 b/s rate. The terminal's FSK responses are visually displayed on its 8-digit display and/or printed via the optionally available Transaction printer.

II. TELEPHONES I AND II

The Transaction I telephone is intended primarily to expedite and facilitate inquiries and transactions in a switched-network, digital-inquiry/voice-answer (DIVA) system. It can automatically dial the telephone number of the data center and fully buffer input data for transmission after contact with a data center. The telephone number and/or the input data may be keyed in manually or entered into the telephone via magnetic encoded cards. An ERASE button on the set corrects errors in manual entries and an ATTN button signals the data center for assistance. The ATTN button can also be used to redial the last number dialed. An END button is used to delineate the data fields and transmit an end of text (ETX) sequence at the conclusion of data entry. Four sequenced instruction lamps guide the user through the data input. Voice answerback or yellow and green response lamps activated upon receipt of a KAT signal can communicate approval or disapproval of a transaction.

The Transaction II telephone provides for *TOUCH-TONE* inquiry/FSK data response applications. It has all the features of the Transaction I telephone: in addition, it has an FSK data receiver and a 120-character buffer for accepting and storing data sent from a data center. An eight-position visual display is provided to display responses from the data center and data entered from the set's manual entry pad. The seven-segment LED display can display the numeric and limited alphanumeric characters shown in Fig. 1. Messages up to 119 characters can be displayed eight characters at a time by paging the data via the ERASE button. The Transaction II telephone has ON and OFF buttons for hands-free operation and a call progress monitoring loudspeaker for audible feedback to the user. The Transaction II telephone also has a printer interface for connection to the Transaction printer. Messages from the data center computer, up to 118 characters in length, may be stored by the telephone and delivered to the printer. In normal usage, FSK messages contain control data, display data, and print data. Several FSK messages can be sent in one session, thereby permitting longer messages to be printed.

There is also a volatile last-number-dialed feature. It can be programmed and protected from alteration by manual entries.

III. TRANSACTION TELEPHONE-DATA CENTER INTERACTION

To begin a transaction, the merchant lifts the handset of the Transaction I telephone or presses the ON button of the Transaction II telephone, waits for the dial tone, and inserts first the dialing card and then the customer card. The telephone automatically dials the telephone number of the data center while buffering the merchant and customer data.

At the data center, the ACD (Automatic Call Distributor) queues the call, if necessary, and directs it to the first available computer port. The 407-type data set associated with the port answers the call and sends the 1.5-second answer tone.

While the call is being dialed, set up, and/or answered, the merchant can manually enter data such as the transaction amount or a PIN (Per-

LETTERS

A B C D E F G H I J
L N O P Q R S T U Y

SPECIAL CHARACTERS

- (DECIMAL POINT)
- (DISPLAYED FOR (/) KEY OR FOR TRANSMITTED (-))

Fig. 1—Displayable characters—Transaction II.

sonal Identification Number). When the additional data have been entered, the merchant presses the END button. When the answer tone ends, the Transaction telephone begins to transmit the buffered data. If all the data in the buffer go out before the merchant has finished manual entry, the remaining keyed data are transmitted as they are entered.

The data center computer processes the incoming data and decides whether or not to approve credit. It then sends the appropriate response to the Transaction telephone. If credit is approved, an appropriate audible response and/or a 1.5-second answer tone for green light activation is transmitted. If not, an appropriate audible response and/or a 3-second answer tone for yellow lamp activation is transmitted.

The Transaction telephone acknowledges receipt of the answer tone by sending a *TOUCH-TONE* signal *a* (green lamp) or *TOUCH-TONE* signals *b* (yellow lamp) to indicate the set is ready to receive a detailed voice message associated with a referral or some other appropriate action. If no audio followup is necessary, the merchant hangs up and the computer disconnects the call. If the merchant doesn't hang up, the computer times out to allow the call to disconnect.

The Transaction II operation is identical to that described for I except that the call progress sounder is generally muted as data transmission begins and the response selected by a dialing card character can consist of FSK signals to light or blink the green and yellow lamps and activate the display and/or printer. If the response is in FSK, the message begins with the ASCII STX character as shown in Fig. 2a. The response message from the data base consists of three fields. The first field is the action field which contains all the terminal control information as shown in Fig. 2b. The second and third fields are the display and the print fields. If a print field is present, a test is made for the presence of a printer and paper. If there is no printer, then the print field is ignored. If the printer is there but there is no paper, then the word "PAPER" is displayed. When paper is inserted, "PUSH END" is displayed. After the END key is operated, the display field is paged by operating the ERASE key. When the last page* is on the display, the print field is printed.

A positive or negative acknowledgment of FSK messages is returned to the data center. A negative acknowledgment is a request for retransmission of the FSK message. When the telephone receives and executes an error-free message, it returns a positive acknowledgment. The telephone will hang up automatically if instructed to do so in the FSK message, or it may be hung up via the OFF button. If the telephone does not receive a hang-up command, it will disconnect 20 seconds after a positive acknowledgment of the message. A hang-up code is sent just prior to disconnecting from the telephone line.

* A page consists of 8 characters or is terminated by a "/". The / is not displayed.

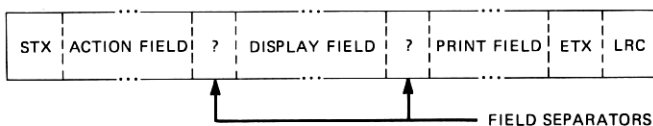

(a) RESPONSE MESSAGE FORMAT

- 0 - SET AUTOMATIC DISCONNECT TIMER TO 3 MINUTES
- 1 - "NAK" - RETRANSMIT LAST MESSAGE
- 2 - UNMUTE CALL PROGRESS TONE SOUNDER
- 3 - DO NOT CHECK MESSAGE LRC (MUST APPEAR IMMEDIATELY AFTER STX)
- 4 - RESERVED FOR FUTURE USE
- 5 - ACKNOWLEDGES END OF DISPLAY/ACKNOWLEDGES SUCCESSFUL OR UNSUCCESSFUL PRINTING
- 6 - LIGHT GREEN RESPONSE LAMP
- 7 - LIGHT YELLOW RESPONSE LAMP
- 8 - BLINK LAMP
- 9 - DISCONNECT, SEND * * *

(b) ACTION FIELD CHARACTERS

Fig. 2—Response format/action field.

IV. DESIGN OF TRANSACTION TELEPHONES

The Transaction telephones are designed around the Rockwell MOS/LSI PPS4 microprocessor system. This is a five-chip system consisting of a Central Processor Unit (CPU), Random Access Memory (RAM), Read Only Memory (ROM), general-purpose input/output device (GP I/O), and a clock chip. A block diagram of the Transaction II telephone is shown in Fig. 3. Since Transaction I is a subset of Transaction II, the following discussion will be limited to Transaction II. Input/output ports interface with medium-scale integrated circuits to implement the Transaction II features described above. Besides controlling the interfacing circuits, the microprocessor does message decoding, error checking, and printer control and tabbing. The design intent is to simplify the peripheral circuitry by utilizing the power of the microprocessor.

The network signaling and line supervision are controlled via a manual or hands-free line circuit as shown in Fig. 4. The manual operation is implemented with a *TRIMLINE*® handset and a mechanical switchhook (SWHK), whereas the hands-free line circuit consists of a microprocessor controlled mute relay (M), line relay (L), dial relay (D), dial tone sounder, and terminating network. The mute relay enables the transmit and receive circuits and eliminates handset interference.

Direct-current dial-pulse network signaling is accomplished via the

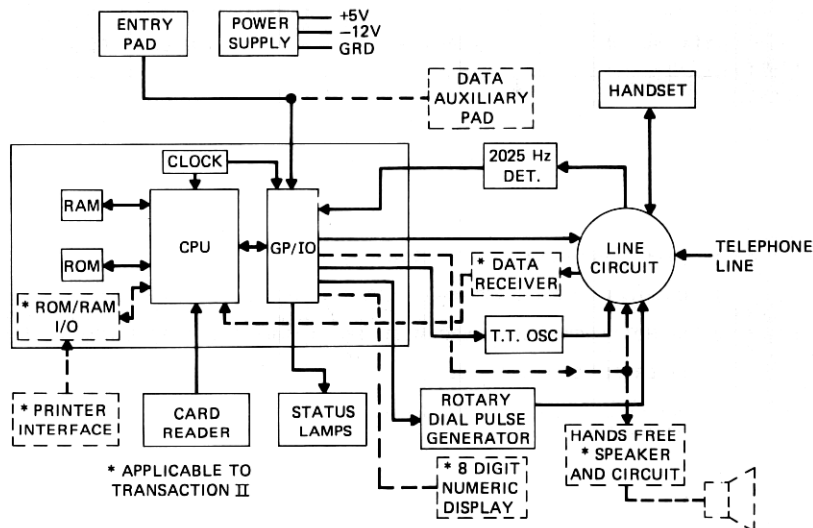

Fig. 3—Transaction telephone.

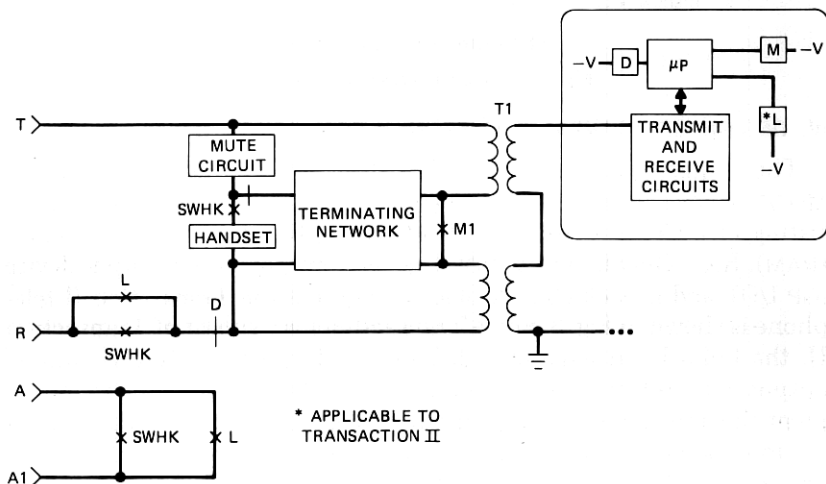

Fig. 4—Line control.

microprocessor-controlled relay (D) or a 220 *TRIMLINE*-type handset. *TOUCH-TONE* signals are generated by a 2220 *TRIMLINE* type handset or a line transformer-isolated transmit circuit under control of the microprocessor's keyboard and card reader inputs. Sixteen keyboard entry pad inputs are multiplexed via a two-phase clock using eight inputs of the microprocessor system. The microprocessor reads the keyboard, card reader input, or auxiliary entry pad and activates the correct 2-out-of-8 *TOUCH-TONE* signaling oscillator (559G hybrid integrated circuit) inputs for network signaling and/or end-to-end data transmis-

sion. In normal operation, FSK response messages rather than KAT messages are expected in answer to an inquiry. Response messages are decoded via a keyed answer tone (2025 Hz) detector or a low speed (110 or 150 b/s) frequency-shift keyed (FSK) data receiver. The FSK receiver consists of an input filter, a limiter, a product demodulator, and a dual integrator carrier detector. The KAT receiver is a resistive, tuned, phase-lock loop.

Messages are decoded by the microprocessor and conveyed via the response lamps, the numeric display, and/or printer to the user of the Transaction telephone.

The response and instruction lamps are light-emitting diodes (LEDs). The display is an eight-digit (seven segments per digit plus decimal point), serial mode static display. Each display is driven by an 8-bit serial-input, parallel-output, low power TTL shift register.

Transaction II is designed to work with an optional Transaction printer. The printer is interfaced to the Transaction II telephone microprocessor system via a memory/input-output device of the PPS-4 family. This is a parallel data interface with data-strobe and data-ready signals. Information to be printed and control characters to format the printing are received in the FSK message to the Transaction II telephone.

The Transaction telephone design permits certain features to be optioned in or out to accommodate particular customer requirements. The set's dialing mode is controlled by an option strap to be either *TOUCH-TONE* or dial-pulse. An option strap also inhibits dialing via the manual entry pad. This option is referred to as "keyboard lockout" and is used to restrict dialing except by a dialing card. Another dialing option is the "one number option," which restricts dialing to a single data base. When this option is activated, the set must be used as a repertory dialer. Once the repertory has been loaded, the set does not accept dialing cards and requires only a customer card to initiate operation of the Transaction telephone features. Following a power failure, the repertory contents are lost and must be reloaded.

The design also incorporates an interface for an optional data auxiliary PIN pad (5000A DIAL) to accommodate the use of PIN numbers. The PIN pad is activated via a pushbutton switch on the face of the Transaction telephone. LED lamps light on the pushbutton and the PIN pad to indicate that the PIN pad is active. The Transaction telephone obscures all manual entries when the PIN pad is active by placing the letter P on the visual display for each entry.

The Transaction telephone provides A-lead control and may be used in key systems by the installation of a key strip.

The Transaction telephone has options (Table I) that are controlled by the dialing card. These optional features are designed into the Transaction telephone without the expense of circuit hardware, and are enabled by programming the telephone via the dialing card.

Table I — Transaction telephone dialing card controlled options

1. Green-yellow response lamps enable.
2. FSK receiver enable and data rate selection.
3. Dialing mode change—dial pulse to *TOUCH-TONE*® or *TOUCH-TONE* to dial pulse for split mode dialing.
4. Two-part dialing enable.
5. Response mode in computer down—controlled by floor limit.
6. Repertory dialer disable.
7. Customer card LRC check inhibit.
8. Predialing enable.

The card reader is designed to read magnetic stripe cards encoded on track 2 according to the American National Standards Institute, Inc. (ANSI) standards for credit cards. The reader is hand-powered and has no moving parts. It can read cards driven as slow as 4 inches per second and as fast as 30 inches per second.

The encoding technique on the magnetic stripe is known as two-frequency, coherent phase encoding. This scheme combines serial data and clock information on one recording channel. A flux transition occurring between clocking transitions defines a 1, and the absence of an intermediate flux transition defines a 0. The data are a synchronous sequence of characters without intervening gaps. A block diagram of the card reader is shown in Fig. 5. This circuit dynamically tracks changes in the card velocity by using the previous clock interval to generate the data sampling point. A magnetic head reads the biphas encoded signal. The signal is amplified, integrated, and shaped to produce a bipolar non-return-to-zero signal. This signal is applied to an edge detector which produces a unipolar pulse for each flux transition read from the magnetically encoded card. The time between these pulses varies as the speed

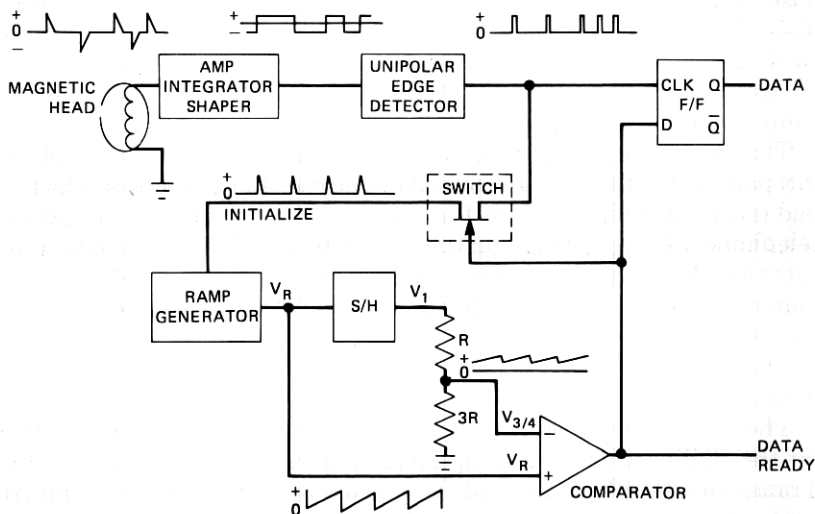

Fig. 5—Card reader.

at which the card is driven through the reader; hence, the clock and data bit periods vary.

The circuit assumes that a 1 bit edge pulse comes before three-fourths of the time required for two successive clock pulses has elapsed. Any pulse occurring before the three-fourths point is assumed to be a bit center pulse and corresponds to a 1. This assumption is based on the fact that a flux transition occurring between clocking transitions defines a 1 and the absence of an intermediate flux transition defines a 0.

A ramp generator, a sample and hold (S/H) circuit, a switch, and a comparator are used to derive the clock and data from the unipolar encoded pulses. The switch is controlled to pass successive clock pulses (i.e., only if the present time period is at least three-fourths of the previous time period). Pulses that occur earlier than three-fourths of the time between the previous two pulses are not used to reset the ramp generator. Hence the ramp generator's output (V_R) is a function of the bit length. The S/H circuit output V_1 is proportional to the period of the preceding bit. Three-fourths of V_1 ($V_{3/4}$) is compared with V_R . Hence, the comparator's output always changes to a high state three-fourths of the way into a bit and remains in a high state until the ramp generator is reset. The output of the comparator directs the clock pulses through the switch and acts as the data input to the flip-flop (f/f). If no pulse is applied to the f/f between clocking pulses, the data out is a high state or a zero data bit. If a data pulse is applied to the f/f between the clocking pulses, the comparator output is a LOW state and the data out changes to a low state or one data bit. The next clock pulse then resets the ramp generator, references the S/H circuit, and resets the data flip-flop.

The magnetic stripe cards are encoded with a string of leading zeros to establish an initial bit period. A card sense switch is synchronized with the leading zeros, which indicates the data are valid.

The sets operate on ac power. The power supply design incorporates a linear transformer and integrated circuit regulators to provide 5-percent regulated dc voltages. The power supply responds to overloading via foldback current limiting and thermal shutdown. Also, transformer protection is provided by a primary thermal cutout and secondary fusing.

V. DESIGN OF TRANSACTION TERMINAL

A simplified block diagram of the electronics used in the Transaction III terminal is shown in Fig. 6. The set must be plugged into locally available power, 117V ac \pm 10 percent, 60 Hz. An integral power supply is capable of producing 1.1 A at +5V and 0.2 A at -12 V. The supply utilizes a linear power transformer with dual secondaries and monolithic integrated circuit voltage regulators.

The heart of the electronics and the control for all functions performed by the terminal is a microprocessor. The one used in the Transaction III

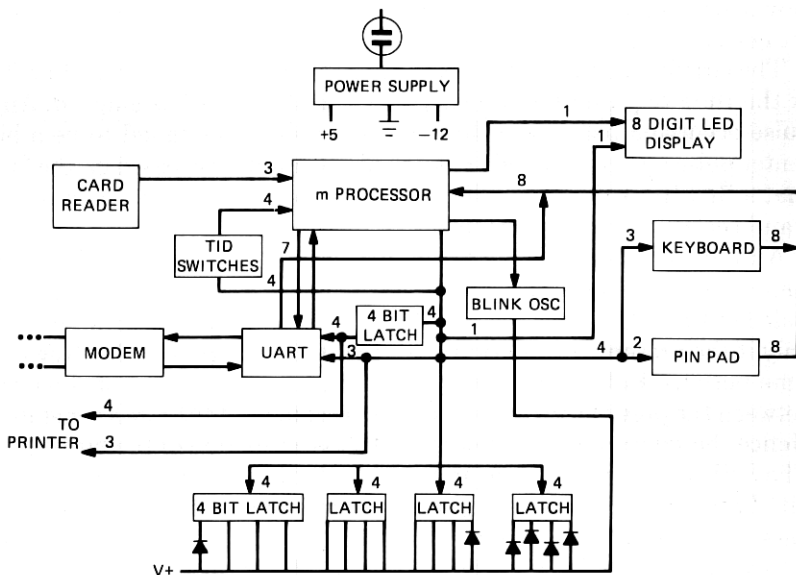

Fig. 6—Transaction III block diagram.

terminal is the same as that used in the Transaction I and II, the Rockwell PPS-4. This is a 4-bit microcomputer system which executes most instructions in $5 \mu\text{s}$.

The microcomputer system used in the Transaction III terminal is made up of six integrated circuits. The central processing unit performs the instruction decodes and contains the arithmetic logic unit, program counter, stack, memory address register, etc. A clock driver uses a common 3.57954-MHz color TV crystal and produces the two clock signals required by the rest of the system. Two 16-kb read-only memories provide the program storage. A 2-kb random access memory is sufficient for buffering both the transmit and receive messages as well as the pointers, flags, and scratch pad memory required.

The microprocessor's peripheral circuitry primarily interfaces to it via a 4-bit output bus and an 8-bit input bus. Four 4-bit TTL latches are used to both drive and store the state of the instruction, call progress, and response LEDs that appear on the face of the unit. Five of the LEDs, which are sometimes required to blink and at other times be continuously on, have their anodes returned to the output of the blinking oscillator. This is then controlled by an output from the microprocessor.

5.1 Terminal Identification (TID)

Each terminal contains switches for setting a four-digit terminal identification number. The terminal identification switches consist of an array of 16 switches, physically realized in two DIP packages. The

switches are organized as a 4×4 array, using the 4-bit output bus to strobe the rows, and four processor inputs to read the columns. Two DIPs containing eight diodes each are used to isolate the switch cross-points.

5.2 Keyboard

The main and PIN pad keyboards are read in a similar manner. Together, they may be thought of as a 4×8 array with 19 buttons on the main keyboard and 12 on the PIN pad. Again, the 4-bit output bus provides the strobe signals. However, input is provided on the 8-bit bus. Isolation diodes are again used to prevent one keyboard from interfering with the other. Button decoding and debouncing are provided by the software. This keeps keyboard hardware to an absolute minimum.

5.3 Modem

The processor's interface to the modem is primarily via a universal asynchronous receiver transmitter (UART) device. The 7-bit-wide transmit data are supplied by an LPTTL 4-bit latch and the processor's output data bus. The 7-bit-wide receive data are multiplexed onto the processor's input bus between strobes to the keyboards. At other times, the bus remains in its high-impedance state. Control signals to and from the UART go directly to the GPI/O device.

The modem contained in the Transaction III is a 1200-b/s, two-wire, half-duplex, frequency-shift keyed type, compatible with and using the same technology as the *DATAPHONE*[®] 202S and 202T data sets. This includes the use of hybrid integrated circuit active filters and large-scale integrated circuit modulator and demodulator. The modem includes a self-test feature. The System Ready lamp on the face of the terminal is normally on and will blink off whenever carrier is detected. However, when the reset button is depressed and held, the modem loops the transmit signal back to the receiver and verifies a quasi-random data pattern. If successful, the System Ready lamp will remain off until the reset button is released.

5.4 Card Reader

The card reader used in the Transaction III is a new type employing the magneto-resistive effect. The head contains a ceramic chip patterned with permalloy (a magneto-resistive material), conductor patterns, and an acrylic coating. The total package has much the same shape and size as a conventional magnetic head. See Ref. 1 for further information on the physical design of the reader.

Two permalloy detectors, spaced one-half bit width apart, are patterned on the chip. This allows decoding of the biphase signaling pattern encoded on Track 2 of a credit card in a speed-insensitive manner. This

is illustrated by the block diagram in Fig. 7a and the timing diagram in Fig. 7b. After the signals from each detector are amplified and squared up, clocking information is retrieved by simply ORing those signals and dividing by 2. The one-shot multivibrator is needed to satisfy timing constraints at the interface with the microprocessor. Data are recovered by ANDing the detector outputs with the toggle flip-flop output and using that to set another flip-flop. This flip-flop is then reset at the end of the clock cycle.

The speed-insensitive nature of the detection allows the use of a card reader consisting of a slot through which the card is passed by hand. The reader will accept card velocities from approximately 2 in./s to 40 in./s. The head in this reader is itself sprung, allowing it to better conform to irregularities on the card. The result is an inexpensive magnetic card reader that is very easy to use.

VI. SOFTWARE

The functional operation of the Transaction telephone is implemented via its microprocessor software. The software comprises approximately 3000 assembly language instructions and resides in 4000 8-bit bytes of ROM storage. Organization of the software is accomplished by dividing the set's operation into five major states. Each of the states controls the set's operation during a particular portion of its activity. These states are Idle, Merchant Data Input, Customer Data Input, FSK Data Receive, and Rekey.

The primary function of the various states are as follows:

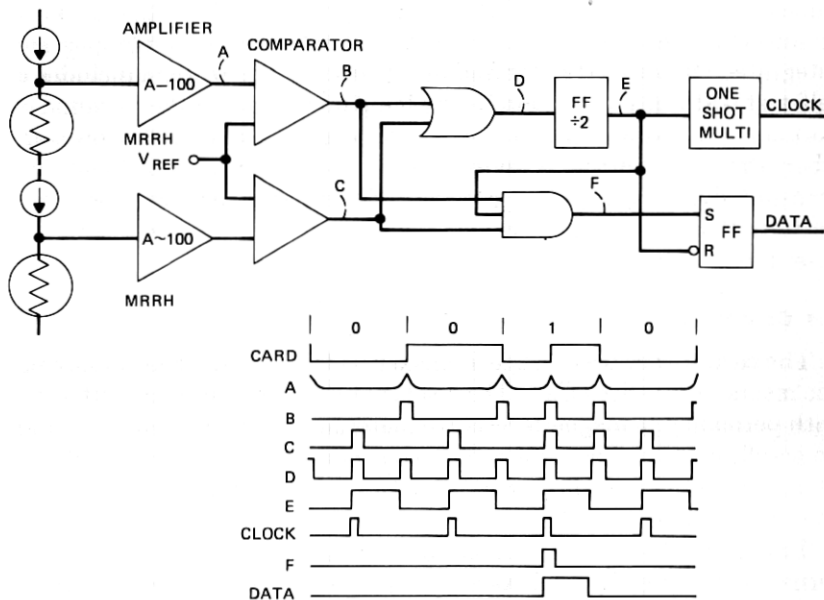

Fig. 7—Magneto-resistive card reader.

- (i) Idle—Detect start of transaction (off-hook detection).
- (ii) Merchant—Store telephone and merchant number. Enable option and response modes. Output pulse telephone number.
- (iii) Customer—Store customer number and transaction data (e.g. dollar amount, PIN, etc). Output pulse inquiry message.
- (iv) FSK Receive—Decode FSK response message. Execute response message. Execute data link protocol.
- (v) Rekey—Decode KAT response message. Output pulse follow-up inquiry messages.

Control is passed between these states as appropriate in order to implement the over-all system requirements. Detailed operation internal to the states is accomplished by calling a set of subroutines in conjunction with testing various control flags stored in RAM. Some of the most interesting subroutines are described in the next section.

VII. SUBROUTINE FUNCTIONS

7.1 Key reading

When a key is operated on the manual data entry keyboard, it is the key reading subroutine (RDKEY) that detects the key, decodes it, covers contact bounce, and protects against multiple keys.

Keyboard data are given to the CPU through two 4-bit input ports. Each bit represents one of two keys, depending on the state of an output bit. The two ports are each read twice on each RDKEY cycle, thereby testing each key.

RDKEY takes approximately 800 μ s to execute. This is the longest routine and accounts for the major portion of time used in each state except FSK. Because of this, RDKEY provides its own timing for bounce protection.

RDKEY scans the keyboard, testing for a key operation. If a key is found and no other key is operated, it is decoded and a counter set to inhibit further scanning for 40 ms,* thereby implementing bounce protection. RDKEY returns to the main program, indicating that a key was operated and which key it was. After the 40-ms passes, the keyboard is again scanned. As long as the same key is detected, the routine returns to the main program, indicating no key. As soon as no key or multiple keys are detected, the counter is set to inhibit scanning for 20 ms, and the routine continues returning an indication of no key. If a different key were detected after 40 ms, it would be handled the same as a new key operation.

* During this interval, each time RDKEY is entered, approximately 800 μ s are wasted to maintain timing.

7.2 Card reading

The card reading subroutine (CDRD) receives the card data, stores it in a specified RAM location, tests character parity and card LRC, and signals the end of a card. CDRD is entered when the main program detects the presence of a card in the reader. There are three inputs to the CPU from the card reader: a data lead, a clock lead, and a switch lead indicating card in reader.

CDRD monitors the three leads, looking for a clock pulse. When the clock pulse is found, the data lead is sampled and the bit stored. One character consists of 5 bits, 4 data and 1 parity. Initial character framing is achieved by matching the incoming bit pattern with the hex character B, which is the first character on all cards. Each time a character is received, it is loaded in RAM, its parity checked, and then added to the previous characters to form the LRC. The end of card data is signaled by the hex character F. This is followed by the LRC character which is matched with the LRC generated by CDRD during the read. Since this character does not appear on all cards, this test is optional. The return to the main program indicates whether the card was read correctly (parity, LRC) or not. If at any time during the reading the card sense switch opens, control is immediately returned to the main program, indicating a bad read.

7.3 FSK receiver

The FSK receiver subroutine (RDFSK) monitors the data lead from the FSK receiver and detects the start of an FSK character. Once the start is detected, the subroutine maintains control of the set until the entire character is received. It then decodes the character, distinguishes between control and data characters, tests character parity, and updates the message LRC.

The FSK character consists of 10 bits. There is one start bit (0), 8 bits (7 ASCII, 1 parity), and one stop bit (1). Between characters, the data input lead stays at 1.

RDFSK monitors the data input lead looking for a "start edge," i.e., a 1-to-0 transition. If it does not find one, it returns control to the main program. Upon detecting a start edge, the routine times for 1/2-bit time, constantly monitoring the input lead. If the lead returns to 1 any time during the 1/2-bit time, RDFSK assumes it was a noise pulse and returns to the main program. If the lead remains at 0 the entire time, then RDFSK assumes it is a valid FSK character and proceeds to receive it.

RDFSK receives the FSK character by timing for 1-bit time, then sampling the data lead. Each time the lead is sampled, the bit is stored in a register and also added to the sum of the previous bits as a parity check. After 8 bits are received, the data lead is monitored until it becomes a 1, indicating the stop bit. The parity of the character is tested

and the message LRC is then updated. The data are stored in RAM as they are received in a location reserved for the FSK message. If the character was a data character, then the pointer to the message location is updated to the next location. If the character was a control character, a control code is returned to the main program and the data discarded by not updating the pointer. In this way, only data characters are stored in RAM.

7.4 Outpulsing

Two subroutines are involved in outpulsing: RDEDGE, the routine that monitors the outpulsing clock and detects when it changes state, and OUTPL, the routine that actually does the outpulsing.

The number to be outpulsed is stored in a specific section of RAM. The specific digit is indicated by an outpulse pointer.

The timing for the outpulsing is provided by the outpulsing clock. The *TOUCH-TONE* oscillator is turned on at the leading (positive) edge and turned off at the trailing (negative) edge of the clock. The Dial Pulse (DP) circuit is both enabled and disabled at the trailing edge of the clock. The outpulsing clock is monitored by RDEDGE. When an edge is detected, OUTPL is called. OUTPL determines which edge has been detected and if the outpulse mode is TT or DP. If it is a leading edge and DP, no further action is taken. If it is a leading edge and TT, the TT oscillator is turned on to the frequencies representing the digit indicated by the outpulse pointer. The LRC and Character Count (CC) are also updated at this time. If it is a trailing edge and TT, the TT oscillator is turned off. The return to the main program in this case indicates that the outpulsing of the digit is complete. All the logic for DP outpulsing is done on the trailing edge of the clock. On the first edge of a new digit, that digit is stored in a temporary RAM location and the DP outpulsing circuit enabled. On following edges, the digit is counted down until it is zero, when the DP outpulsing circuit is disabled. At the same time, another counter is set to be counted down in the same manner to form the interdigit time. The return on the edge on which the DP controller was disabled indicates to the main program that the digit was outpulsed.

VII. CONCLUSION

The Transaction telephones and terminals provide efficient operation in short message inquiry/response systems. The user is provided with easy data entry modes (magnetic card reader and manual keyboard data entry) and sequenced instruction lamps. The responses (audio, visual, and printed) are clear and concise.

The Transaction telephone design utilizes a microprocessor to implement its numerous features. The employment of the PPS-4 microprocessor has permitted complicated hardware to be eliminated. The

functions of the sets are written in software which interfaces with simplified peripheral circuitry. This is clearly evident in the interface of the Transaction II telephone with the Transaction printer. The Transaction telephone's software totally controls the operation of the printer.

The Transaction III terminal augments the dial Transaction telephones by providing service over dedicated exchange facilities. It is expected to find use in those applications that have high transaction volumes.

The use of a microprocessor makes the design features of the stations flexible and future feature offerings possible.

The development of stations with different features is possible with a software development and little or no hardware design. This permits a Transaction telephone to be updated with the demand for new features from the marketplace.

REFERENCES

1. D. D. Banks, G. A. Bhat, and J. W. Wesner, Jr., "Transaction Network, Telephones, and Terminals: Physical Design of Transaction Terminals," B.S.T.J., this issue, pp. 3503-3515.