

No. 4 ESS:

The Switched Digital Network Plan

By J. E. ABATE, L. H. BRANDENBURG, J. C. LAWSON,
and W. L. ROSS

(Manuscript received August 2, 1976)

A plan for the introduction of time-division switching in the intertoll network is outlined. The plan uses the No. 4 ESS as the switching vehicle. The plan defines a Switched Digital Network (SDN) which can evolve compatibly with the existing Switched Analog Network (SAN). The plan introduces 64 kilobits per second time-division multiplexed PCM as a standard switching signal format in the intertoll network. Facilities utilization, trunk design, timekeeping, and maintenance plans which are required for the new format are presented. Effects on intertoll network evolution, particularly voice performance, are assessed.

I. INTRODUCTION

The selection of a digital format for the No. 4 ESS switch represents a significant step in the continuing evolution of the intertoll network in the United States. This selection was dictated by the economics of advancing technology and by the requirements for a large toll switch which could economically satisfy current and projected volumes of intertoll service.

Economic considerations, however, must be bounded by the requirements of a viable technical plan for the installation and operation of a digital toll switch in an evolving intertoll network which is now analog and which will remain substantially analog for many years in the future. This paper outlines the basic characteristics of the network plan for introducing digital switching into the intertoll plant.

The plan proposes direct interconnection of digital transmission facilities, digital switches, and analog-to-digital converters to form a Switched Digital Network (SDN).

Facilities in the SDN will be the No. 4 ESS switch; a set of digital transmission facilities which carry digital bit streams on paired wire, coaxial, radio, and millimeter waveguide at rates from 1.544 megabits per second to 274 megabits per second; a set of analog-to-digital converters which include D-type channel banks using the $\mu = 255$ D2 coding law and the Voiceband Interface Frame (VIF); and a digital interface, the Digroup Terminal (DT), which permits direct digital interconnection between the No. 4 ESS switch and digital transmission facilities. This facilities set will permit a digital connection to be established from a local (class 5) switch through the intertoll network to a distant local switch. Additionally, the plan provides for compatible interconnection with the existing switched analog network (SAN) so that the intertoll DDD network can include both the SDN and the SAN as its evolution continues.

This plan introduces two new types of trunks into the telephone plant. In addition to the existing 4-kHz analog trunk, digital trunks and combination trunks will be required. Digital trunks transmit and receive a 64 kilobit per second PCM format. They interface with No. 4 ESS at both ends through the digroup terminal (DT). Combination trunks interface with 4-kHz analog at one end and 64 kilobits per second at the other. The analog end terminates in a D-type channel bank and the digital end in the DT.

The introduction of these two new types of trunks changes long-established viewpoints of network engineering, transmission objectives, and maintenance. Digital trunks, in particular, require new objectives and maintenance procedures. They also require the operation of a nationwide timekeeping plan.

Digital switching offers a new opportunity for integration of switching and transmission equipments. From the origin of telephony to the present, switching and transmission systems have been integrated into a telecommunication network at a 4-kHz baseband interface. Progress in both switching and transmission has been constrained by the traditional requirements of the interface which affect both transmission and signaling. The introduction of a 64 kilobit per second PCM signal in a word-organized time-division multiplex format offers significant opportunities for improved performance, and reduced capital and operational costs.

Section II provides a basic overview of the network plan for the SDN, an overview of the major differences between the SDN and the SAN, and the expected mode of evolution of the SDN.

Section III provides some details of the SDN plan in the areas of signal formats, facilities utilization, trunk design (loss and level designs), timekeeping, and maintenance. Space does not permit a complete description. Details such as idle channel code selection and facilities provisioning are included. These details were critical elements requiring

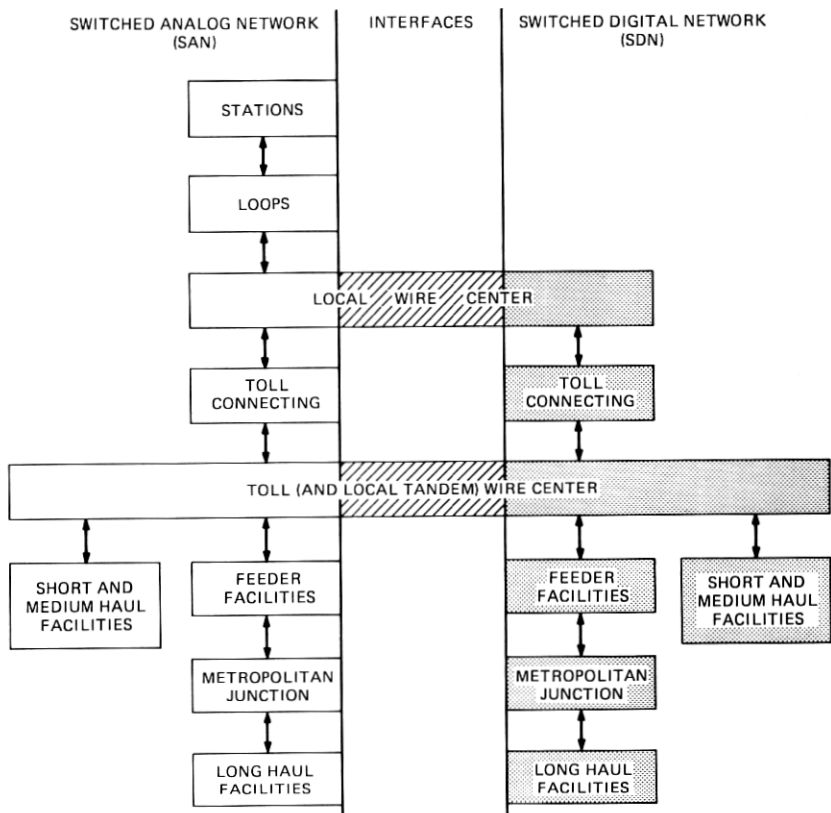

Fig. 1—Functional organization of the SAN, SDN, and interfaces.

specification so that a viable technical plan could be realized.

Section IV assesses expectations of voice performance of the network as the SDN evolves. Section V concludes with a summary of trends which begins as the SDN is introduced and notes some currently perceived issues which are to be resolved as future technology develops.

II. SDN PLAN IMPACT ON DDD NETWORK EVOLUTION

The introduction of No. 4 ESS and with it, the SDN plan, will have impact on the DDD network from the viewpoints of new engineering and operational methods and economics. This section gives an overview of these viewpoints as perceived at the present time.

2.1 Compatibility of the SDN with the SAN

Compatibility of the SDN with the SAN is the dominant constraint for the introduction of No. 4 ESS and the SDN into the current DDD network. Figure 1 broadly illustrates how the SDN will interface. The SDN is

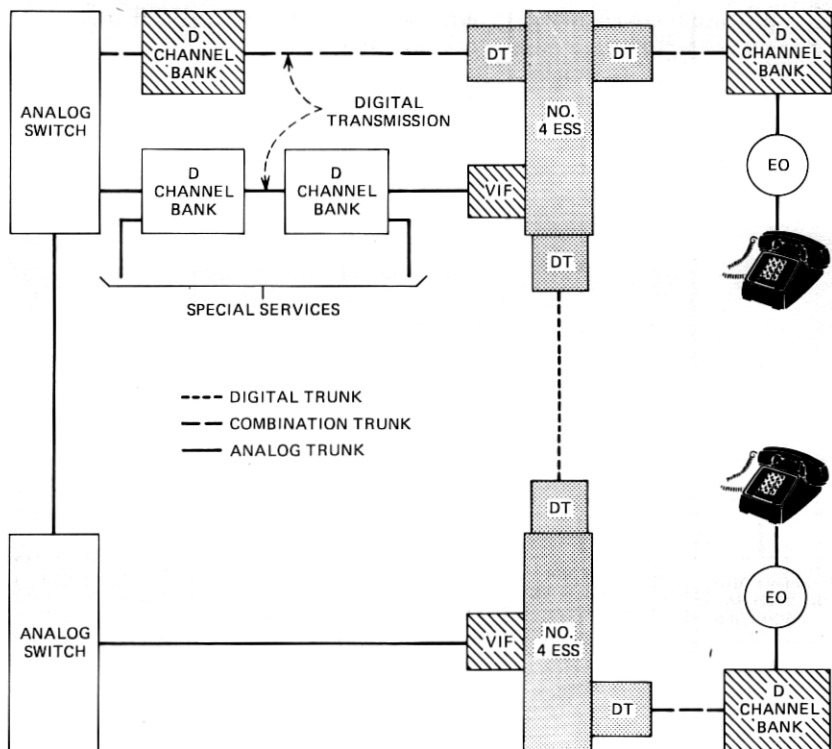

Fig. 2—Simplified configuration of analog, digital, and interface facilities as parts of the SAN and SDN.

constructed exclusively with digital transmission and switching facilities. In contrast, the SAN is constructed with analog switches, and a mixture of digital and analog transmission systems. These two facilities networks are distinct. Interconnection will occur at toll and local wire centers where analog-to-digital conversion occurs.

Traditionally, transmission and switching designs in the DDD network have adopted a standard 4-kHz interface which permits route selection by the switch to be made independently of transmission facility type, and to be dependent only on route destination and traffic engineering and design considerations. The SDN introduces a second interface standard which is a $\mu = 255$ PCM word-organized digital format¹ in a way which preserves the traditional method of route selection by the switching machine. Figure 2 illustrates, in more detail, the component parts of the SDN, and the way 4-kHz and 64 kilobit per second interfaces coexist in the combined SAN SDN network that will be the DDD network of the future. As shown in Fig. 2, traditional switching functions are maintained by the introduction of two new trunk types, digital and

combination, which were defined in the previous section. As a result of these choices, it is expected that the basic functional and service characteristics of the intertoll network will be unchanged by the introduction of the SDN.

2.2 Impact of SDN plan on the DDD network

The SDN plan impacts the engineering and operation of the DDD network in four areas. These are trunk design, facilities utilization, maintenance, and synchronization.

The selection of a signal format, and loss and level plan, represents a significant change from traditional standards in the network. These choices, which are detailed in Sections 3.1 and 3.3, simplify maintenance, level administration, and trunk design and minimize the need for digital processing. The significant features of this plan are:

(i) The $\mu = 255$ PCM format described in the D2 channel bank specification¹ becomes a network standard.

(ii) Loss and level administration merge into a unified plan rather than being treated independently as in the past.

(iii) A digital milliwatt test signal becomes a standard at all test points in the SDN; furthermore, this test signal is compatible with the analog milliwatt test signal in the SAN.

(iv) The preservation of bit integrity through the network offers opportunities for simplified and enhanced maintenance, and the promise of enhanced voice performance.

Direct digital interconnection of digital and combination trunks on No. 4 ESS changes facilities utilization in three significant ways:

(i) Significant economies have been demonstrated by directly terminating the digroup, which is a 24-channel TDM-PCM signal carried on 1.544 megabit per second facilities. These economies are sufficient to eliminate the use of voice-frequency cable in the toll connecting trunk plant and to stimulate the use of T1 carrier significantly.

(ii) The 24-channel digroup becomes the basic unit in facilities provisioning instead of a single circuit. Past practices of intermixing message channels and private-line channels on transmission facilities requires modification. Section 3.2 describes a plan called modified segregation in which the majority of message trunks and private line channels are carried on segregated facilities.

(iii) Channel numbering and trunk numbering in switching machines are strongly interrelated because of the sequential nature of the 24-channel word (time slot) organized TDM-PCM digroup. The SDN plan uses the straightforward one-to-one correspondence between channel,

time slot, and trunk (traffic) number with the expectation of simpler and more straightforward data base and record administration.

Maintenance of the SDN will be simplified because of the opportunities for automatic error monitoring in digital switches and digital facilities. Significant economies will occur in the maintenance of digital trunks, since a successful test of one digital trunk in a digroup will assure the performance of the remaining 23 trunks.

Finally, the introduction of the SDN into the DDD network requires the introduction of a synchronization or timekeeping plan. A timekeeping plan, described in Section 3.4, is designed to maintain synchrony between parts of the SDN to about one part in 10^9 when the network is stressed because of equipment failures. Normally, timekeeping will be maintained to accuracy attainable with atomic clocks. The timekeeping plan will provide a level of performance which makes timekeeping impairments substantially smaller than impairments caused by hits, outages, and equipment failures.

2.3 The Evolution of the Switched Digital Network

The SDN will be formed as No. 4 ESS machines are installed and are interconnected via short, medium, and long-haul digital transmission systems as dictated by economics. Thus, the manner in which the SDN grows and evolves is a function of the economical sequence in which No. 4 ESS's are installed throughout the Bell System for both growth and modernization, and the existence of digital transmission facilities where they prove-in over their analog counterparts. This section describes how these economic considerations will dictate a particular mode of evolution of the SDN, called "islands," and discusses some of the operational characteristics that result from such a mode.

Beginning with the introduction of four No. 4 ESS machines in service within the Bell System at the end of 1976, and a projection of several score more by the end of the decade, the SDN will emerge. It should be emphasized again that the timing and location of this installation sequence is determined by the economics of each installation on a case-by-case basis and not solely on the pre-existence of digital carrier systems. During this same period, as in the past, the Bell System will be installing short-haul digital carrier and also medium-haul digital systems when the case-by-case economics so dictate. Economic studies have shown that the lower cost of terminating digital carrier on the No. 4 ESS does substantially reduce the prove-in distance of T1-carrier, resulting in considerably greater use of T1, but has a limited ability to prove-in additional long-haul digital systems over those which would be economical with conventional analog terminations. Thus, it is expected that the SDN will materialize in metropolitan clusters of "islands" intercon-

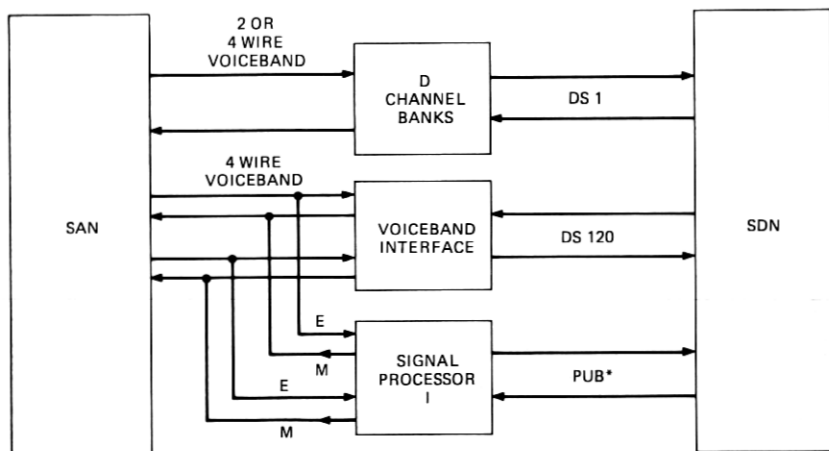

*PUB = PERIPHERAL UNIT BUS

Fig. 3—Interface terminals between SDN and other communication networks.

nected by digital transmission systems that are short enough that the termination savings possible with the digroup terminal will have a measurable effect on total system economics. It is only later, when long-haul digital systems prove-in on their own merit, that a nationwide SDN will result.

In summary, then, the early years of the SDN will be marked by three characteristics: clusters of No. 4 ESS machines in "islands," a large number of combination toll connecting trunks and a smaller number of short digital trunks within islands, and a limited digital interconnection of islands with long-haul digital facilities.

These characteristics of SDN evolution have dictated the form of the timekeeping plan (Section 3.4). This plan, as will be seen below, capitalizes on this mode of evolution. It will provide an orderly transition from a group of SDN islands to a nationwide, fully interconnected SDN.

III. NETWORK PLAN

3.1 Signals Within the SDN

In this section, the idle channel code signal and the two interface signals between digital transmission and switching equipment within the SDN are briefly described. The two interface signals are referred to as the DS-1 and the DS-120 signals. Typical appearances of these signals are illustrated in Fig. 3. The idle channel code is the digital signal transmitted by the No. 4 ESS on digital and combination trunks when such trunks are in the idle (on-hook) state.

3.1.1 The DS-1 signal

The DS-1 signal carries one "digroup" (i.e., twenty-four 64 kilobit per second channels). The digroup is the lowest or first multiplex level in the SDN. It is a 1.544 megabits per second signal, organized into frames of 193 bits repeated at a rate of 8000 frames per second. Twelve such frames constitute a superframe of 2316 bits. The frame consists of twenty-four 8-bit words, called time slots, plus a 193d bit, which alternates in function between framing and signaling subframe.

Frame integrity is preserved in the SDN by aligning incoming DS-1 frames at the No. 4 ESS. Such alignment requires one-frame storage in the DT. However, superframe integrity is not retained in the SDN, since superframe alignment at each No. 4 ESS would cause a signal delay approaching 2 milliseconds at each switch. Such delays would cause greatly increased echo suppression costs. Thus, when channels on two distinct digroups are connected through the No. 4 ESS, the signaling bit transmitted from the No. 4 ESS will most likely occupy a bit position formerly occupied by PCM information on the incoming digroup. The impact of signaling frame realignment (called digit robbing) on SDN transmission performance is not expected to degrade service. Further, the planned transition to Common Channel Interoffice Signaling (CCIS) will eliminate the need for digit robbing.

The lowest level cross-connect in the SDN is at the DS-1 digital speed, or in groups of 24 voice channels. This characteristic of the SDN represents one of the most fundamental changes from current practice. In effect, it preserves digroup integrity throughout the network and legislates against per-circuit access for cross-connecting on a digital basis. This characteristic of preserving digroup integrity permits maintenance opportunities and efficiencies heretofore not achievable in the current analog network, as discussed in Section 3.5.

3.1.2 The DS-120 signal

The No. 4 ESS may receive inputs from either of two interface terminals: the DT or VIF. The signal passing between these two interfaces and the Time-Slot Interchange (TSI) is referred to as the DS-120 signal. This signal is identical whether it originates from the DT or VIF. Thus, the switch need not keep track of which of these facilities the DS-120 signal originates from. The DS-120 bitstream can accommodate the 120 VF trunks processed by a VIF or five digroups processed by a DT. It is organized into a frame of 2048 bits with a frame rate of 8 kiloframes per second. The DS-120 signal is described in detail in another paper in this issue.

3.1.3 Idle channel code signal

To ensure that all statistical and syntactical constraints on digital bitstreams within the SDN are met, No. 4 ESS will transmit an "idle

channel code" in all time slots corresponding to idle switch terminations. This code will prevent transmission impairments either on the digital facility or at A/D converters at the SDN boundary. The idle channel code will be generated within the Time-Slot Interchange (TSI) unit of No. 4 ESS. The format of the idle channel code is repetitive transmission of the code word 01111111.

The following describes the rationale for selecting the idle channel code and its point of generation in the SDN.

The reason for generating the idle channel code at the TSI is that it must be generated at a location where the busy/idle state of every trunk is easily accessible. This information is an integral part of No. 4 ESS operation and is readily available at the TSI; it will not be readily available to transmission equipment in a CCIS environment.

The statistical constraints on the minimum number of "ones" that a PCM word contains derives from the need for a T1 bitstream to provide sufficient timing energy in the signal to accurately time the regenerators of a T1 repeatered line. The requirement is that each 8-bit PCM word must contain at least one "one."

Repetitive transmission of a single 8-bit word is desirable because the TSI output buffer memory, where idle channel code generation seems most appropriate, is capable of storing at most one 8-bit word per channel per frame. It is relatively simple to read one predetermined word into the output time-slot buffer memory when a time slot becomes idle. There does not appear to be sufficient need for a more complicated code.

The idle channel code must satisfy syntactical constraints in order not to imitate any of the patterns used for terminal framing, signal framing, and alarm functions.

The requirements on the idle channel code are as follows:

(i) The idle channel code is to be a sequence formed by repetitive transmission of a single code word read toward the line at the No. 4 ESS TSI during periods when the switch termination is idle.

(ii) The word must contain at least one "one".

(iii) Digit 2 of the word must be a "one" because a repetitive zero would be interpreted as an alarm.

(iv) The word must not decode to a significant analog value at the SDN boundary.

The four constraints above are satisfied by repetitive transmission of code words of the $\mu = 255$ inverted binary coding algorithm, near to the center of the coder characteristic. The word 01111111 is chosen for two reasons. Its slightly lower ones density results in less crosstalk impairment of crosstalk-limited digital transmission facilities, notably T1, and because, if a T1 line fails in such a way so as to produce all "one's," the

failure condition is more easily distinguished from the normal idle channel code sequence.

3.2 Facility utilization plan

In the current analog network, digroups terminating on channel banks are often filled with a mixture of different types of message trunks and special service circuits. All circuits are returned to voiceband at each switch. Thus, by cross-connecting at voiceband, message trunks terminate at the switch and special service circuits can be routed as required. However, use of the digroup terminal to terminate a digroup on the No. 4 ESS digital switch excludes the possibility of trunk appearances on a distribution frame, resulting in the loss of individual circuit access. Therefore, special plans are needed to accommodate the presence of special service circuits.

The plan to be followed in the SDN can be described as a modified segregation plan. Strict segregation requires that digroups entering a digroup terminal be composed solely of message trunks terminating on the No. 4 ESS.

The imposition of a strict segregation rule would decrease the efficiency of utilization of transmission facilities. In some cases, additional digroups beyond those needed with current practice will be required. A decrease in digroup fill of about 5 percent has been estimated. Since the digroup fill will now be applied to No. 4 ESS switching equipment, such as signal processors and time-slot interchange units, the same reduction in fill occurs on switching equipment.

In addition, a strict segregation policy would require more effort for circuit layout. This, however, may not be a serious problem. In return for this extra effort, segregation would help to reduce the number of distribution frame appearances and consequently, their associated problems of space, installation, and data-base records. By fostering facility provision for No. 4 ESS on a digroup basis rather than one circuit at a time, segregation should also help to simplify future rehomings and rearrangements. However, the plant is not now segregated, and thus must be groomed for future segregation for No. 4 ESS.

Because of the likely reductions in fill as described above, total segregation may not provide as much savings as might appear at first, and a modification of the segregation policy which maintains facility fill is the recommended plan. The plan for facility utilization with No. 4 ESS is as follows: A policy of segregation will be followed where economic, but where segregation would cause unacceptable transmission cost penalties, a digroup may contain a mixture of switched and other circuits. About 97 percent of the digroups can remain in a segregated format, without a reduction in fill. Thus, the digroup terminal can still be used in most cases, but circuits on "mixed" digroups will be demultiplexed

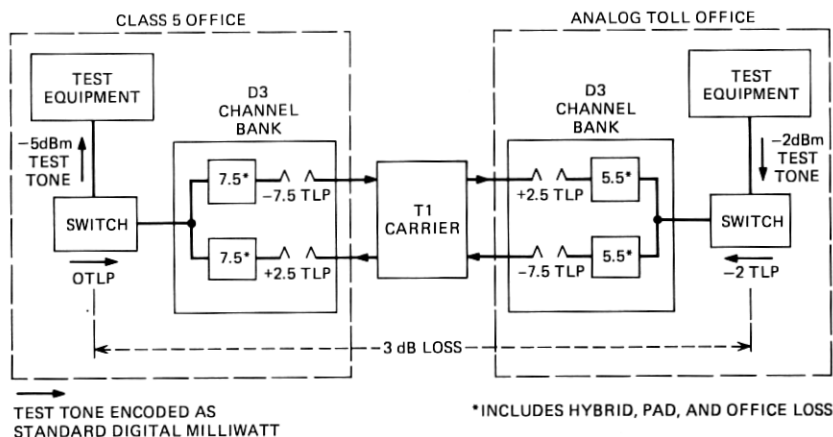

Fig. 4—Method of providing 3-dB toll connecting trunk loss in the SAN.

and decoded by a D channel bank, and must enter the No. 4 ESS through the voiceband interface. Circuits in these “mixed” digroups could also be permanently switched (“nailed-up”) rather than demultiplexed, if this capability is available for No. 4 ESS.

3.3 Loss and Level Plan

The effect of echo is currently controlled by the judicious use of trunk loss and echo suppressors. If these same techniques were used within the SDN, digital loss would be required. Since provision of digital loss would introduce additional cost and transmission impairments as well as require more administration, a study² was conducted to investigate whether loss is needed in digital trunks. This study showed that zero-loss digital intertoll trunks would suffice if the following conditions were met:

- (i) Toll connecting trunk loss was fixed at 3 dB.
- (ii) Digital echo suppressors were used on long digital trunks.
- (iii) All toll connecting trunks should achieve or exceed a terminal balance requirement of 22 dB on the average, and none less than 16 dB.

The provision of 3 dB toll connecting trunks in the SDN requires a change in level administration as shown in the following. The provision of 3 dB toll connecting trunks in the current analog network using T1 with D3 banks is shown in Fig. 4. (The receive test build-out pad is not included.) Note that in this case the receive level at the toll switch is 3 dB below the reference level, 0 TLP at the class 5 office; and the receive level at the class 5 office is 3 dB below the toll switch reference level, -2 TLP (0 TLP is often used on the toll connect side of toll switches instead of -2 TLP, but

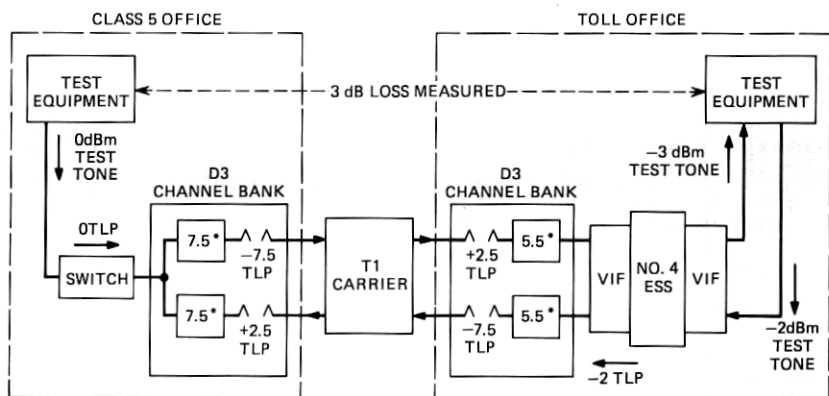

*HYBRID, PAD, AND OFFICE LOSS IN dB

(a)

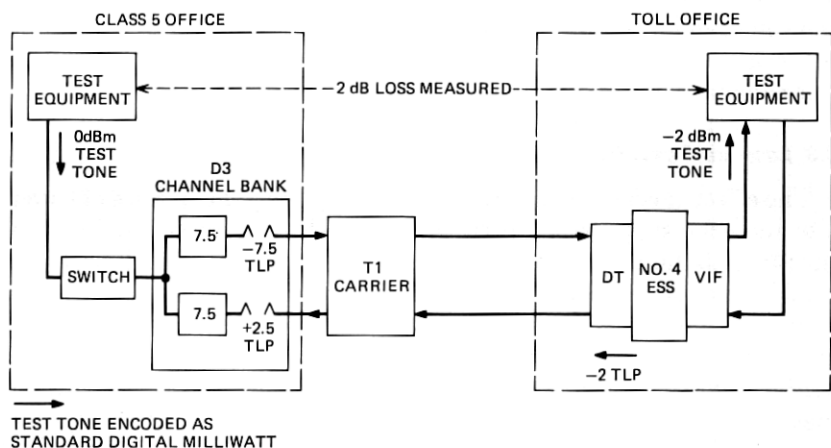

TEST TONE ENCODED AS
STANDARD DIGITAL MILLIWATT

(b)

Fig. 5—(a) Provision of 3-dB toll connecting trunk with No. 4 ESS defined as -2 TLP. (b) Loss for toll connecting trunks when a DT is used with the No. 4 ESS defined as -2 TLP.

for our purposes -2 TLP will suffice to demonstrate the problem). This same technique can be used with the No. 4 ESS and VIF as demonstrated in Fig. 5a. The VIF in the figure is designated as a -2 TLP, meaning that the VIF would encode a -2 dBm tone into the standard digital milliwatt and would decode a digital milliwatt into a -2 dBm tone. When a DT replaces the D3 and VIF as shown in Fig. 5b, the technique does not work. Note that a 0 dBm tone transmitted from the class 5 office would appear

as a -2 dBm tone at the No. 4 ESS test position, indicating a 2 dB trunk instead of a 3 dB trunk.

To resolve this problem, one of the following would suffice: (i) redesignate the class 5 office as a $+1$ TLP; or (ii) redesignate all toll offices as -3 TLP. The first solution has been ruled out primarily because of the cost involved in modifying all class 5 test equipment. The second solution has been partially ruled out because of the cost of converting existing toll offices. However, it has been decided that No. 4 ESS offices will be designated as a -3 TLP. This solves the problem in the long run, of providing 3 dB combination toll connecting trunks, as demonstrated in Fig. 6, where the VIF is now designated as a -3 TLP. However, this so-

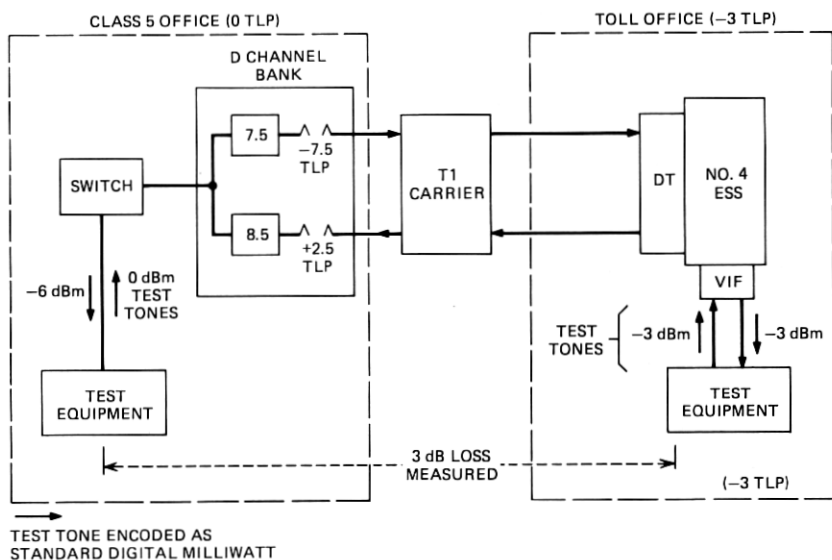

Fig. 6—Provision of 3-dB toll connecting trunks with DT and with the No. 4 ESS as -3 TLP.

lution causes problems during the evolution of the SDN, because analog toll offices will still be a -2 TLP. As a consequence, combination intertoll trunks will be designed to have 1 dB loss as illustrated in Fig. 7.

The loss plan for the SDN is designated the fixed-loss plan and specifies a fixed 3-dB loss for all toll connecting trunks, 0-dB loss for digital intertoll trunks, and 1 dB for combination intertoll trunks. Intertoll trunks utilizing analog facilities are designed to via net loss. The No. 4 ESS will operate at a -3 TLP and existing analog switches will be at a -2 TLP. This loss plan is summarized in Fig. 8. The plan for combination toll connecting trunks was shown in Fig. 6.

In conjunction with the above loss plan, digital echo suppressors will be used on digital intertoll trunks longer than 1850 miles.

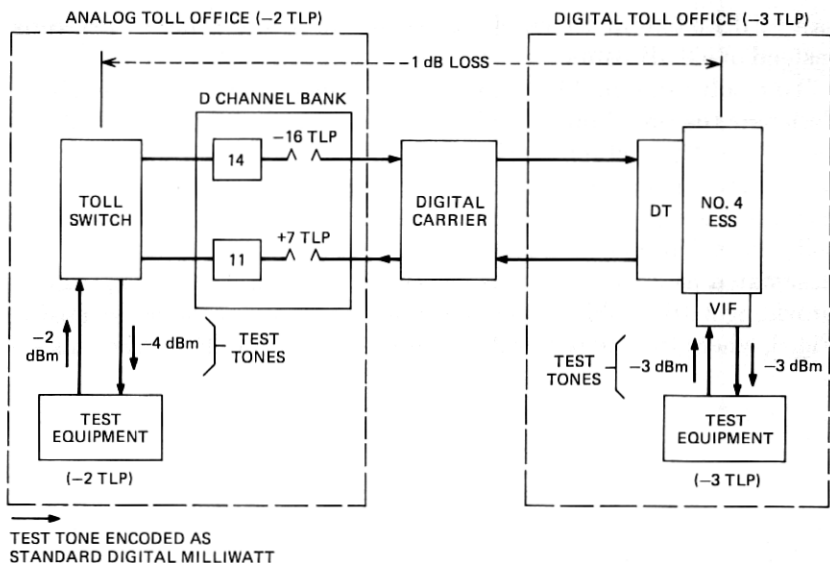

Fig. 7—Provision of intertoll combination trunks (1 dB only).

3.4 Timekeeping Plan

3.4.1 A slip rate objective

Each No. 4 ESS switch will have a clock that controls its output frame rate as well as its internal timing. A signal to be transmitted over a digital trunk leaves the originating No. 4 ESS in digital form at a rate determined by that switch's clock. After transmission, the signal is read into a buffer in a digroup terminal at the terminating No. 4 ESS; the read-in rate is of course that determined by the originating switch. However, the signal is read out of the buffer at a rate controlled by the terminating switch's clock. It is clearly desirable that the read-in and read-out rates—or equivalently, the relative rate difference between No. 4 ESS clocks—be very nearly identical on the average. For example, if the read-out rate is too fast, then eventually the buffer will be scanned twice in succession while occupied by the same frame, i.e., the frame will be repeated. Conversely, if the read-out rate is too slow, then eventually a frame will be overwritten before being read out, i.e., the frame will be deleted. The phenomena just described, the repetition or deletion of an entire frame, are referred to as *slips*. Slips are one of the basic impairments to which signals in the SDN will be subjected. Like all other impairments, slips cannot be eliminated. But the objective of the time-keeping plan is to control slips to within tolerable limits.

Evidence with regard to the effect of slips on voice signals indicates that most slips are inaudible. However, the SDN will also carry voiceband

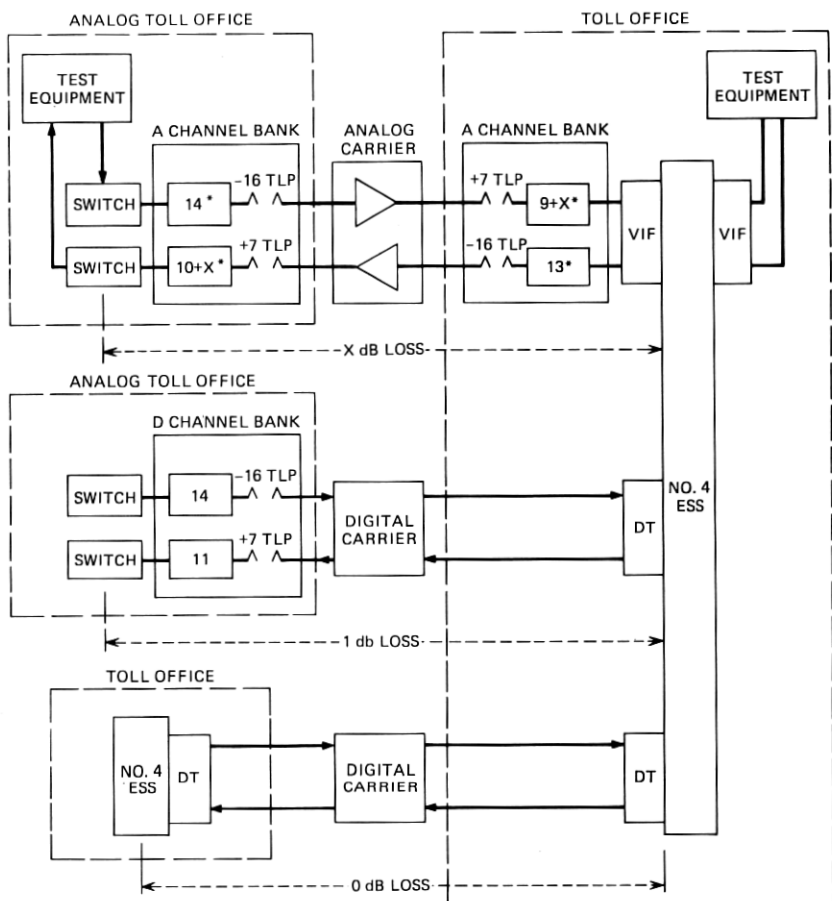

* PAD AND OFFICE LOSS, X = DESIGNED INSERTED LOSS

Fig. 8—Provision of intertoll trunks within the SDN and between the SAN and SDN.

data signals and the effect of slips on these can be much more serious; a single slip can impair the operation of some data sets for several seconds. A specific objective that has been adopted for the SDN is based primarily on voiceband data requirements. The slip rate objective is at most one slip in 5 hours on an end-to-end connection. Based on a reference connection of two intertoll trunks, two toll connecting trunks (this is longer than for most intertoll calls), and accounting for the possibility of digital local offices, the slip objective is at most one slip in 20 hours per trunk. Since the duration of a frame is 125 microseconds, the slip rate objective leads immediately to a clock accuracy objective of 1.7 parts in 10^9 for the average relative rate difference between clocks. The specific goal of the timekeeping plan is to satisfy the clock objective. In fact, the

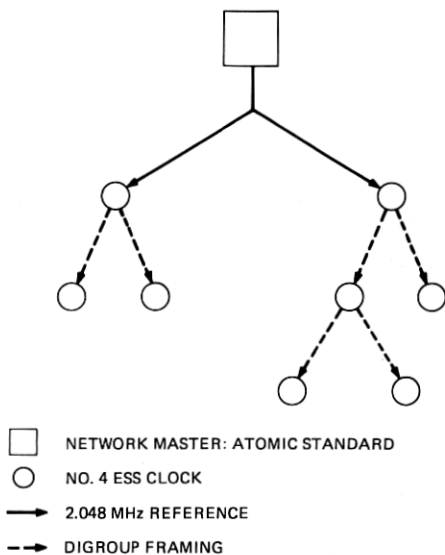

Fig. 9—Master-slave timing structure.

scheme to be described will do much better; under most conditions (including most carrier outages or failures) performance should be virtually slip free.

3.4.2 Basic features of the timekeeping plan

The timekeeping plan provides for the following three basic features: (i) a master-slave hierarchical timing structure, (ii) stable local clocks at each No. 4 ESS, and (iii) the means to phase-lock a local clock to one of two different types of external reference timing signals.

The concept of master-slave synchronization of clocks is shown in Fig. 9. The arrows represent facilities over which timing information is carried. The direction of the arrows indicates the direction of timing flow so that a clock at the head of an arrow is "locked" to the clock at the tail. In the SDN, this locking can be described as a loose phase-locking. Care must be taken in setting up and administering the timing structure that a strict hierarchy is maintained; such anomalies as timing loops should not occur. This is an especially important consideration during a temporary reconfiguration of the hierarchy for maintenance purposes.

The clocks in Fig. 9, with the exception of the network master, represent the local No. 4 ESS clocks. These clocks have a measured frequency stability of better than one part in 10^{10} per day. In the event of a failure on one of the timing links, the No. 4 ESS clock can "free-run" and in the free-run mode it would take in the worst case (linear drift with initial frequency offset) at least 3 days before a single slip occurred. On the other

hand, carrier failures typically last less than a few days. Thus, such failures could easily be bridged by free-running clocks.

The network master is not a No. 4 ESS clock; rather it is a standard reference obtained from the Bell System Reference Frequency Network (BSRFN). The BSRFN is being deployed to meet the stringent demands of the new high-capacity analog transmission systems such as L5. An atomic standard located in Hillsboro, Missouri near the geographical center of the country provides a precise reference frequency at 2.048 MHz.^{3,4} This reference is transmitted without regeneration over analog cable and radio systems to regions throughout the country. Recent field trials have shown that reference frequency signals can be transmitted over cable and radio facilities for a thousand miles with a propagation error of less than one part in 10^{11} over a 15-minute measuring interval.

The actual timing structure in the SDN will be based on a partition of the network into timing regions. The deployment of No. 4 ESS switches is expected to exhibit an initial clustering near metropolitan regions, with digital interconnection within each cluster but no digital interconnection between clusters. These clusters were referred to as SDN islands in Section 2.3. They are geographically separated areas of digitally interconnected No. 4 ESS switches and they form natural timing regions. One switch in each island is "elected" the master for that island, and the other switches in the island are slaved directly or indirectly to the master. The paths used for timekeeping purposes are a subset of paths in the communications network. Timing information appears on every path in the form of digroup framing bits. Thus, special equipment is needed to bridge onto a digital bit stream, detect the framing, and feed derived timing information to the clock.

With the introduction of medium- and long-haul digital facilities the previously established islands will become digitally interconnected. It will be expedient for administrative, maintenance, and performance reasons to retain separate timing regions. For example, such retention will place natural limits on the length of timing chains that can be formed. But there now has to be timekeeping between islands. For this purpose the master in each island will be slaved to the BSRF.

3.4.3 The clock and its interfaces

Figure 10 shows in stylized form the No. 4 ESS clock and some of its interfaces. Note that the blocks shown as isolated units in the figure do not necessarily correspond to physically isolated hardware components.

The figure indicates three reference inputs; two are T1 lines and one is an analog system carrying the BSRF. A particular No. 4 ESS may have only two inputs. If the switch is a slave, the BSRF input would not appear.

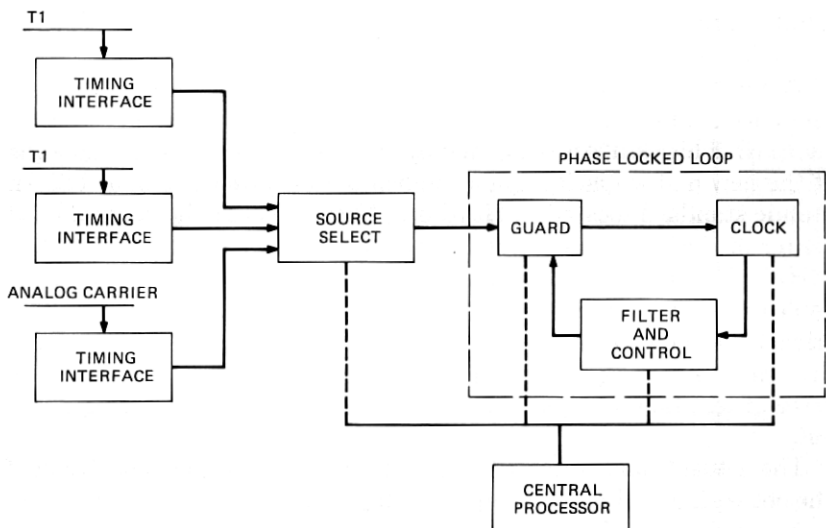

Fig. 10—No. 4 ESS clock interfaces.

But a slave should have two sources of timing via framing on digital communication paths, preferably over physically separated systems. One source would be used as a spare for maintenance purposes. If the switch is a master then the BSRF input is necessary. In addition, it would be desirable to have provision for a framing reference, again for maintenance purposes.

The blocks labeled *timing interface* accept as input an external reference: either the 2.048 MHz BSRF from analog carrier, or a digroup from, for example, T1 carrier. They produce as output an extracted timing signal at an integral subfrequency of the No. 4 ESS clock frequency. One of these extracted timing signals can be chosen by means of a source selector to provide the timing reference for the clock.

The next major subdivision of the figure is a digitally controlled phase-locked loop consisting of three blocks. The guard box performs several functions including detection of reference outage, initiation of the source select (via software), opening the phase-locked loop in order to make the clock free-run, and correction for sudden phase discontinuities due, e.g., to protection switches. The clock consists of four coupled crystal oscillators but can operate with only one working. Each oscillator has a frequency stability of better than one part in 10^{10} per day. As mentioned previously, this degree of stability permits the clock to free-run and bridge most carrier outages or failures and yet produce virtually no slips. The final box labeled filter and control determines the dynamics of the loop.

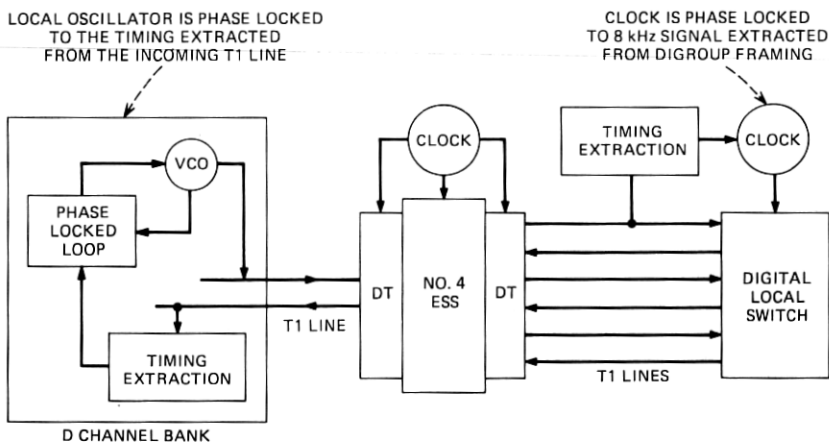

Fig. 11—Timing of channel banks and local digital switches when connected to the DT.

3.4.4 Channel banks and local switches

Other equipment will also interconnect with the No. 4 ESS as illustrated in Fig. 11 and will require accurate timing. D channel banks will be digitally connected to the No. 4 ESS. The special requirement for D channel banks is that they must have the means to be loop timed, i.e., to have the local oscillator phase-locked to the timing of the incoming signal and return this timing to the far-end No. 4 ESS. We must also account for the possible introduction of digital local switches and their digital interconnection with the No. 4 ESS. Recall that for the derivation of the slip rate objective for trunks, the toll connecting trunks in the reference connection were assumed to terminate on digital local switches. Thus, the introduction of digital local switches per se is consistent with the goal of the timekeeping plan, which is to control the end-to-end slip rate. A possible method for extending timekeeping to the exchange area is shown in Fig. 11.

3.5 Digital trunk maintenance plan

3.5.1 Special characteristics of digital trunks

The basic task of maintenance in any telecommunications network is to ensure adequate performance of the network. But maintenance activity in a digital network will be different than in an analog network for several reasons. One of the underlying reasons for this difference is that different performance parameters are measured on digital trunks. Transmission through an analog trunk is subject to noise, loss, echo, and various types of distortions. Transmission through a digital trunk is

subject to only three impairments: errors, misframes, and slips. An error is the erroneous substitution of a zero for a one or vice versa in the bitstream at any point in its transmission. Misframes can occur at a multiplex or digroup terminal, and are usually caused by the masking of framing bits by an error burst, or by the displacement or omission of framing bits due to protection switching in the upper levels of the digital hierarchy, or by propagation of misframes in other facilities in the hierarchy. During a misframe, the affected equipment searches the incoming bitstream for a bit with the right framing pattern; this search effectively produces a noise burst that can last tens of milliseconds. Slips, as defined in the previous section, cause an entire frame to be deleted or repeated. Transmission performance on digital trunks is thus characterized by (i) error rate, (ii) misframe rate, and (iii) slip rate. Jitter is not a separate problem since the digroup terminal buffer will absorb jitter. Excessive jitter can, however, result in slips, or, if the jitter is at a digital repeater, can result in errors. A digital trunk in an integrated digital network has two characteristics which can significantly simplify network maintenance:

(i) For voice circuits which reach a digital switch in multiplexed digital form, individual circuit access will not be available at the digroup terminal. However, per-circuit access is not necessary since a fault that affects a single circuit will almost always affect the digroup in which the circuit occurs. Thus, maintenance activity can be concentrated at the digroup level with a potential 24:1 increase in efficiency.

(ii) Digital systems can potentially monitor themselves. The predominant impairment will be errors, and it is possible to automatically obtain a measure of error rate while equipment is in service. Misframes and slips will be measured and reported by the digroup terminal. Thus emphasis can be placed on automatic surveillance of equipment as a means of controlling network performance.

3.5.2 Maintenance tasks

Maintenance of a telecommunication network takes on different meanings depending upon the viewpoint. From a strictly operational viewpoint, a telecommunication network consists only of switches and trunks; and therefore, only two areas of maintenance—switch and trunk maintenance. However, from an equipment point of view, such a network consists of switches, transmission lines, multiplexers, channel banks, signaling gear, etc. Hence, from this viewpoint, the maintenance job involves the maintenance of this equipment when interconnected in a network. By combining both points of view, a telecommunication network has two basic areas of maintenance—trunk and equipment maintenance.

Up until now, these two areas of maintenance have been relatively

independent of each other. For the SDN, the plan is to merge trunk and equipment maintenance activity as much as it is practicable.

Equipment maintenance consists of the following functions: trouble detection and sectionalization, removal of defective equipment from service, repair and return of equipment to service after repair. SDN maintenance of digital trunks will simplify these functions by requiring the partition of the network into maintenance spans. Each maintenance span will have a monitor at the end of the span so that unsatisfactory performance is detected. These monitors will provide an adequate measure of error rate and should provide a minor alarm when the error rate reaches a level which affects circuit performance and causes it to be degraded. This minor alarm signifies a need for corrective maintenance in order to restore good service within a reasonable time. A major alarm should also be provided when the error rate reaches a higher level which affects network operations. This alarm will cause the faulty system to be automatically removed from service. The major and minor alarm levels in the SDN are nominally 10^{-3} and 10^{-6} errors per bit, respectively.

Several additional techniques will be used to perform the maintenance functions. Automatic protection switching upon a major alarm substitutes a working set of equipment for the failed span. In the case of a multiple failure where a working spare is unavailable, the affected digroup must be removed from service. This will be accomplished by requiring at the failed span that a signal be inserted (such as the all-ones signal) that will inhibit maintenance alarms downstream, but will activate major alarms at the trunk ends. These major alarms will cause trunks to be automatically removed from service. Maintenance functions can also be aided by such centralized maintenance techniques as automatic remote monitoring and alarm pattern analysis because some equipment may not be monitored, and because of the possibility that some faults can produce ambiguous alarm indications.

In view of the above, the trunk maintenance activities of digital trunks will largely be concerned with network administration when faults occur. This administration is concerned with removal of malfunctioning circuits from service, verification of repair, and restoration to service. In addition, a digital test line that can measure error rates on individual digital trunks should be provided so that periodic end-to-end digital trunk testing can be performed as part of the trunk maintenance activity. Such testing will provide further assurance of proper performance and will detect the rare occurrence of single circuit failures.

4. VOICE PERFORMANCE ON THE SDN

4.1 *Noise-loss grade of service*

In order to enter the SDN, an analog voice signal must be encoded into

digital form by a PCM interface terminal (D channel bank or VIF). The PCM encoding and subsequent decoding introduce noise and distortion into the voice channel. In a fully evolved digital toll plant, there will be only one such encoding and decoding on each connection. However, during the evolution of the SDN, when a connection may use a mixture of analog and digital facilities, a path may enter and leave the SDN several times, being subjected to further PCM noise and distortion each time. During the same period of evolution, the introduction of digital long-haul transmission facilities may be expected to reduce the accumulation of noise on long-haul connections, since digital transmission systems do not accumulate such impairments. The question addressed in this section is the evaluation of the net effect of these two competing tendencies, one tending to degrade the grade of service and other tending to improve it.

This section describes the results of computer simulation studies designed to predict the combined noise-loss performance of the DDD network as the SDN evolves. The performance measure is voice grade of service of the transmission quality of telephone connections. The simulation model that was used accounted for the deployment of No. 4 ESS, digital transmission facilities, PCM interfaces, and analog switching and transmission facilities including improved analog carrier such as L4, L5, and TD3.

The computer simulation model used for the DDD network is a modification of a model developed by T. C. Spang.² The approach used in the computer model was to duplicate within the computer the routing and transmission characteristics that could have occurred on a sample of actual calls in the network. From this information, estimates of the distributions of loss and noise were obtained. To these were added an estimate of an equivalent amount of additive noise contributed by a D channel bank or VIF. Estimates of customer opinion were obtained by subjective tests⁵ in which customers rated a call having a given set of transmission parameters on a scale of "excellent," "good," "fair," "poor," and "unsatisfactory." By combining this information with the distributions of occurrences of the parameter, estimates were obtained of the expected percentage of customers who would rate a call "good or better" (good and excellent) or "poor or worse" (poor and unsatisfactory) if a large number of calls are made. These estimates are referred to as "grade of service."

4.2 Results

For the future, as the SDN evolves in the DDD network, the predicted noise-loss grade of service expressed in percent of subscribers rating transmission quality both "good or better" and "poor or worse" is illustrated in Fig. 12. The grade of service is a function of connection

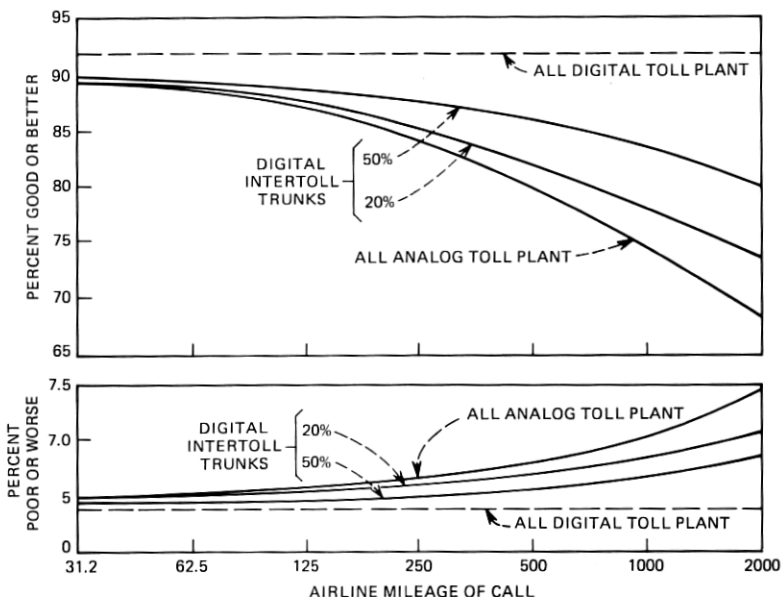

Fig. 12—Noise-loss grade of service of switched network with evolving digital facilities as a function of connection distance.

distance (airline mileage). The curves shown are smoothed versions of the computed results. The “all-digital toll plant” refers to a hypothetical situation when all voice circuits are carried from end office to end office in digital form without intermediate analog-to-digital conversion. The grade of service is predicted to improve as the amount (percentage) of digital connectivity in the toll plant increases. In Fig. 12, two examples (20 percent and 50 percent intertoll trunks are digital) are illustrated. The improvement is more substantial for connections greater than a few hundred miles than for shorter connections. The evolution of digital facilities improves grade of service and reduces the contrast between long and short connections; that is, the improvement is greatest where grade of service is least, at the long distances. For the all-digital toll plant case, no contrast is found between long and short calls.

5. SUMMARY AND FUTURE TRENDS

The introduction of No. 4 ESS and the initial implementation of the SDN mark a transition from existing practices in intertoll telephony to a new intertoll network which will continue to evolve. The plan outlined here has been subject to debate and challenge throughout the development cycle of the No. 4 ESS machine and has been maintained essentially unchanged. Projected economies of digital termination on No. 4 ESS switches are being realized in initial installation. Projected economies

in maintenance are being realized also. The difficult transition from current methods of facilities utilization and trunk provisioning to the new methods required by digroup engineering have been accomplished, and improvements in circuit record data base administration are reasonable expectations. Improvements in voice performance remain a reasonable expectation, but years of evolution will be required to demonstrate them.

One note of caution, however, must be mentioned. A number of planning opportunities or alternatives have been used up by decisions reached to formulate the plan. Such an example is the adoption of a unified loss and level plan which restricts independent evolution of loss planning and level planning. Future technological innovation will be constrained to some degree by existence of this plan for an integrated digital transmission and switching network.

ACKNOWLEDGMENTS

Many contributions have been made by people too numerous to mention. Special mention, however, must be made of the contributions by C. C. Case to timekeeping and maintenance, by M. B. Brilliant to digital transmission objectives, and by W. A. Stubblebine, who defined the idle code plan.

REFERENCES

1. C. L. Damman, L. D. McDaniel, and C. L. Maddox, "D2 Channel Bank: Multiplexing and Coding," *B.S.T.J.*, 51, No. 8, (October 1972), pp. 1675-1699.
2. T. C. Spang, "Loss-Noise Echo Study of the Direct Distance Dialing Network," *B.S.T.J.*, 55, No. 1 (January 1976), pp. 1-36.
3. R. E. Powers, "Reference Frequency Transmission Over Bell System Radio and Coaxial Facilities," *Proc. 28th Annual Symp. on Frequency Control*, pp. 373-379, May 29-31, 1974, U.S. Army Electronics Command, Fort Monmouth, New Jersey.
4. J. F. Oberst, "Keeping Bell System Frequencies on the Beam," *Bell Laboratories Record*, 52, No. 3 (March 1974), pp. 84-89.
5. J. L. Sullivan, "Is Transmission Satisfactory? Telephone Customers Help Us Decide," *Bell Laboratories Record*, 52, No. 3 (March 1974), pp. 90-98.