

No. 4 ESS:

Transmission/Switching Interfaces and Toll Terminal Equipment

By J. F. BOYLE, J. R. COLTON, C. L. DAMMANN, B. J. KARAFIN,
and H. MANN

(Manuscript received July 28, 1976)

The digital time-division switching network of No. 4 ESS imposes new requirements on the transmission/switching interface, while at the same time presenting opportunities for major improvements and economies. Two new terminals—the Digroup Terminal (DT) and the Voiceband Interface (VIF)—perform the interfacing for digital and analog transmission systems, respectively. Access to the switching network itself is via serial PCM links, each accommodating 120 voice-frequency channels. The DT terminates digital facilities and performs the multiplexing/demultiplexing necessary to interface the PCM links at the switch. The VIF terminates four-wire, voice-frequency analog trunks and performs analog-to-digital and digital-to-analog conversion and multiplexing/demultiplexing to interface with the switch. Both terminals incorporate extensive maintenance hardware and reconfiguration capability.

Unitized Facility Terminals (UFTs) are used for a variety of functions—attenuation, signaling conversion, etc.—that must be performed on analog trunks between the basic facility distributing frame on the one side and the VIF and signal processor on the other. The use of UFTs, a standard switching/transmission interface, and modular equipment arrangements and floor plans result in substantial savings in floor space, cabling, and distributing frame requirements, when compared with traditional switching/transmission systems.

I. INTRODUCTION

The nature of No. 4 ESS, together with evolving equipment concepts, has resulted in a streamlined switching/transmission interface with

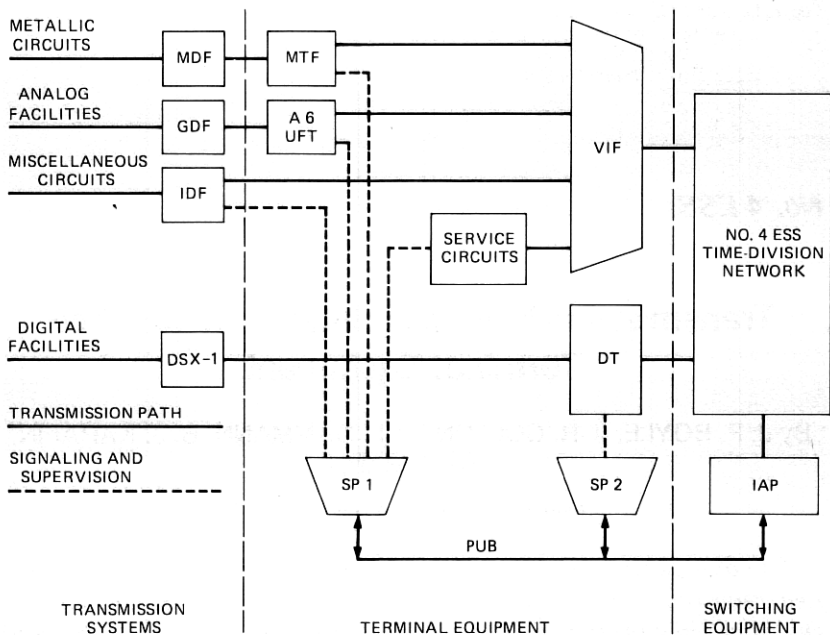

Fig. 1—Transmission/switching interface system.

advantages in cost, space, and maintenance effort. The terminal equipment and arrangement that compose this interface are the subjects of this paper. The interface system is shown in Fig. 1.

The streamlining of the terminal arrangement is clearest in the case of digital transmission facilities. The No. 4 ESS switching network is, of course, a digital time-division network. Serial links into and out of the network use the DS-120 format—an 8.192 Mb/s PCM stream that accommodates 120 voice-frequency channels. Terminals for digital transmission facilities terminate the facility and provide the multiplexing/demultiplexing to interface the transmission format with the DS-120 format. In particular, there is no need to derive each analog channel. Avoiding the conversion step eliminates unnecessary signal degradation as well as the need for a host of per-channel equipment: trunk circuits, distributing frame appearances, etc.

The Digroup Terminal (DT) is the interface for digital facilities in No. 4 ESS. The DT consists of up to eight Digroup Terminal Units (DTUs). Each DTU terminates DS-1 level signals (1.544 Mb/s, 24 VF channels), providing multiplexing of five DS-1 signals for a DS-120 port of the time-division network. The DT also extracts/inserts signaling information from/to the DS-1 streams. Signaling information is then exchanged between the DT and the Signal Processor 2¹ (SP2) by means of a serial 2.048 Mb/s link, again avoiding per channel operations and hardware.

Figure 1 shows the DSX-1, a DS-1 cross-connect frame, as well as the peripheral unit bus connection between the SP2 and the 1A processor.² Note that the DT is the only frame between the cross-connect and a port of the switching network. An overview of the DT architecture appears in Section 2; a detailed description appears in Section 3.

The interface between No. 4 ESS and analog transmission facilities is accomplished by the Voiceband Interface (VIF). The VIF contains up to seven Voiceband Interface Units (VIUs). Each VIU terminates 120 four-wire voice-frequency channels and performs the analog-to-digital and digital-to-analog conversion necessary to interface with the DS-120 link of the time-division network.

The four-wire channel at the VIU is a pure message channel; i.e., signaling, with the exception of MF digits, is stripped from the trunk at the unitized terminal and converted to a standard format—looped E and M—before being passed to the Signal Processor 1 (SP1).¹ The interface format, then, between the analog transmission plant and the switch is a DS-120 PCM stream with looped E and M signaling. Again we note the absence of a trunk circuit in the switch. An overview of the VIF appears in Section 2; the detailed description appears in Section 4.

The variety of functions to be performed on analog circuits between the distributing frames and the VIF and SP are efficiently accomplished with Unitized Facility Terminals (UFTs). For the case of carrier facilities, the A6 UFT family provides, in a single package, the channel units, signaling converters, attenuation pads, and maintenance access. The metallic terminal frame (MTF) terminates the wide variety of metallic facilities and provides conversion to standard levels and signaling format for the VIF and SP1. The arrangement is shown in Fig. 1. The unitized concept is discussed in Section 5.

The combination of unitized terminals, a standard analog interface, and the “natural” simplicity of the digital interface lead to particularly efficient cabling arrangements and office layouts as discussed in Section 5. An example is presented in which this combination of traditional switching and transmission functions into a unified whole results in pronounced savings in floor space, cabling and distributing frames.

II. THE INTERFACE TERMINALS

The basic interface between the transmission plant and the No. 4 ESS switching network is provided, as we have said, by two frames—the DT and the VIF. While the DT interfaces the digital transmission plant and the VIF interfaces the analog plant, structurally the two frames have much in common. In this section we consider some of the similarities as well as some differences in the two frames. In Sections 3 and 4 the frames are discussed individually and in detail.

Many of the similarities in the two frames derive from the fact that both the DT and VIF interface with the switching network using DS-120 PCM coaxial links. The DS-120 is an 8.192 Mb/s serial data signal accommodating 128 encoded voice-frequency channels. (Each 4-kHz voice channel is sampled at 8 kHz and encoded at 8 bits/sample for a rate of 64 kb/s.) Only 120 of the 128 channels are actually used to carry traffic. The remaining eight channels are used to maintain the coaxial links. The choice of a 128 time-slot format with 120 channels is natural in that 120 is a multiple of both the standard 12-channel analog group and the 24-channel digroup (DS-1) used in digital transmission, while 128, being a power of two, is convenient for binary logic.

Seen then from the Time Slot Interchange (TSI),¹ the initial and final stages of switching, the transmission plant is uniformly the same. It is a DS-120 link, whether there is a VIF or a DT on the transmission side.

Each voiceband interface unit (VIU) provides the interfacing between 120 four-wire, voice-frequency, analog channels and a single DS-120 port (two coaxial lines, one for each transmission direction). Similarly, each digroup terminal unit (DTU) interfaces five digital links of 24 channels each to a single DS-120 port. To a first-order approximation, a VIF or DT can be viewed as a frame containing a number of independent units with a duplicated central control.

The structure of a multiplicity of units with a control permits the use of a switchable spare unit to provide service protection. In other words, when a working unit is discovered to be defective, a spare unit is switched in to carry the traffic without interruption. Both the DT and VIF use a 1-for- n protection strategy, i.e., one spare unit for a frame containing n working units. (For DT, $n = 8$; for VIF, $n = 7$.) With automated fault detection and diagnosis, repair of a faulty unit is rapid. The probability, then, of losing service reduces to the probability of two units in a frame failing at nearly the same time. With highly reliable circuitry, service outages are expected to be rare.

The use of a 1-for- n protection strategy affords considerable hardware savings when compared with full duplication. The strategy arises directly from the multiplicity-of-units architecture. By contrast, when the function of a frame cannot be divided into a number of identical, independent units, duplication is often the only viable protection strategy.

Both the DTU and VIU are designed to process 128 VF channels. As we have said, only 120 of these channels are used to carry traffic. Internally, in both units, the spare time slots are used in the fault-detection process. Test signals originating in the controllers enter the units in the spare time slots, are processed by the units as traffic and compared with expected results. Deviations result in alarms and ultimately in protection switching of the unit.

A difference in the two frames is that, since the DTUs process only digital signals, the test signals that the digroup terminal controller (DTC) distributes are digital, while the voiceband interface controller (VIC) must distribute analog tones to test A-to-D conversion, etc.

A primary function of the controllers in both DT and VIF is unit maintenance. Both controllers supply test signals to the units, collect failure data from the units, and control protection switching. To accomplish these tasks, both frames require clock synchronization between units and controller. Both the DTC and the VIC receive office timing from the switch on duplicated clock links, derive necessary waveforms, and distribute timing to the units. The DTC and VIC control 960 and 840 trunks respectively, and hence are designed to be extensively self-checking. They are duplicated to prevent service outages.

When the controllers detect faults either in the units or in themselves they report to the central control (CC)—the 1A Processor.² Software residing in the 1A processor determines and directs any reconfiguration—protection switching, controller choice, etc.—and diagnoses the failure. Like other frames in the No. 4 ESS office, an attempt is made to diagnose the fault to a small number of replaceable circuit packs.

The controllers must communicate with the processor for the alarm, configuration and other functions. Neither the DTC nor the VIC require the capacity of the full Peripheral Unit Bus¹ (PUB)—the system by which many of the switch frames communicate with the processor. The VIC receives orders from CC indirectly via the SP1;¹ it does reply directly on the reply (PURB) and control (PUCB) portion of the PUB. The DTC communicates with the SP2¹ via the 2 Mb/s link. The SP2 in turn communicates with CC via the PUB, acting as a buffer for a number of DTs.

A major difference between the DT and VIF is that the DT must process signaling information while signaling is stripped off analog trunks at the UFT. This difference is reflected in more complex equipment and cabling arrangements for analog trunks. It is also reflected in a difference in the controllers. The DTC exchanges signaling information with the SP2 and hence has a call-processing role. The 2 Mb/s link between the DTC and SP2 carries both service and maintenance information. The VIC, on the other hand, is strictly a maintenance controller and exchanges no service information with the CC.

In summary, the gross architectures of the DT and VIF are very similar. Both frames are composed of a number of independent units that interface the switch using DS-120 links, a spare unit for service protection and a duplicated control. The controllers in both frames receive synchronizing clock from the switch, supply test signals to and collect failure data from the units, control protection switching, and communicate with the central processor with the help of the signal processors.

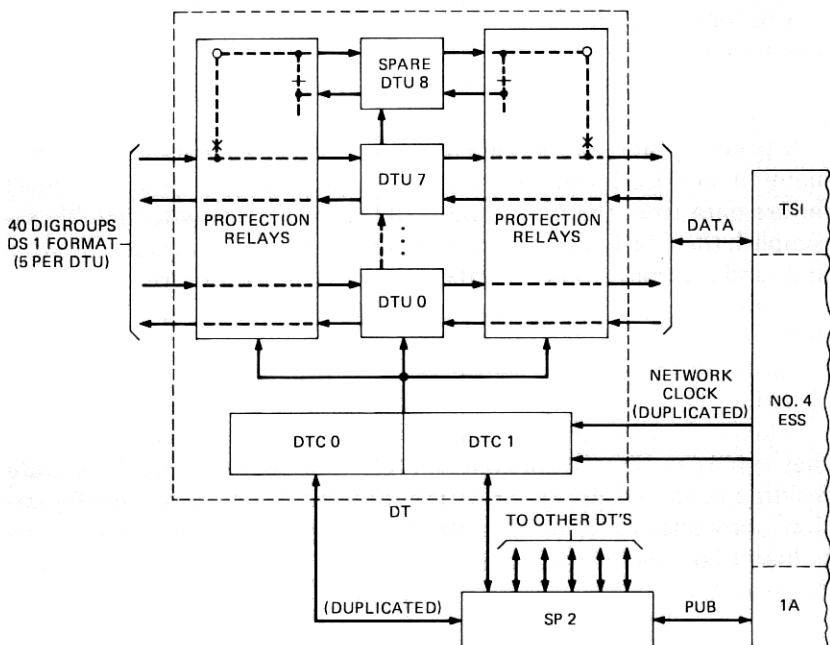

Fig. 2—Digroup terminal block diagram.

In spite of these similarities, there are, of course, important differences between the frames. There is the obvious difference that the DT interfaces digital facilities while the VIF interfaces analog facilities. A second major difference is that the DT has a signaling function that is absent in the VIF.

A more detailed look at the individual frames appears in the next two sections.

III. DIGROUP TERMINAL

3.1 General

The digroup terminal provides the digital processing necessary to terminate DS-1 level digital signals and the multiplexing and demultiplexing required to interface these signals with time-slot interchange ports of No. 4 ESS. As shown in Fig. 2, a DT comprises up to eight normally active digroup terminal units, a switchable spare DTU, and two nearly identical digroup terminal controllers. Each DTU interfaces five 24 channel DS-1 level signals with a single 120-channel TSI port, resulting in a maximum DT termination capability of 40 DS-1 level signals or 960 channels. Clock signals are transmitted to the DTCs from the No. 4 ESS network clock via a TSI. The DTCs maintain the DTUs and provide the

means for high-speed serial exchange of signaling information and DT maintenance messages with Signal Processor 2 (SP2) memory. SP2 processes the signaling information and interfaces with the 1A Processor over the peripheral unit bus. SP2 does not process DT maintenance messages, but instead shuttles them between the DTs and DT maintenance programs resident in the 1A Processor. Up to 16 DTs interface with a single SP2. Up to four of these DTs can terminate DS-1 level signals from trunks that contain imbedded signaling bits; the remaining DTs terminate DS-1 level signals from CCIS trunks.

Detection of service-affecting faults is accomplished autonomously within the DT by hardware techniques, and such faults result in the autonomous generation of DTU or DTC failure-summary messages. These are interpreted by the DT fault-recovery program, which is resident in the 1A Processor, and the faulty subsystem is isolated by reconfiguring the DTUs or DTCs to preserve the existing calls. The DT diagnostic program is later executed to resolve the failure to a small set of circuit modules.

Physically, a digroup terminal frame is a 7-foot by 4-foot, 4-inch structure, as shown in Fig. 3. The circuit packs are standard 1A Technology packs.³ The DT is connectorized to facilitate frame installation, and all external connections are made at the connector panel. The protection switch relays and outgoing line equalizers associated with the DTUs are provided on separate panels. The fuse and alarm panel consists of individual DTU and DTC power switches, out-of-service indications and protection switch status. The communication panel provides telephone and teletypewriter connections and a key to request a frame diagnostic. A DTU occupies three shelves and each controller occupies two shelves.

The remainder of Section 3 consists of a description of the operational and maintenance features of the digroup terminal. First the operational features of the digroup terminal unit will be described, with emphasis on new No. 4 ESS features, such as slip synchronization and common control digital processing. Next, the operational features of the digroup terminal controllers will be treated with emphasis on the novel time-division techniques by which signaling information and maintenance messages are processed and exchanged with SP2. Finally, the maintenance of the DT is discussed, with emphasis on the hardware and software concepts that are unique to the DT.

3.2 Digroup Terminal Unit

A DTU comprises a DS-1 interface, a unit processor, and a TSI interface, as shown in Fig. 4. The DS-1 interface synchronizes the DS-1 level signals to the No. 4 ESS network clock, regenerates the incoming DS-1 level signals, and performs the necessary formatting, multiplexing, and

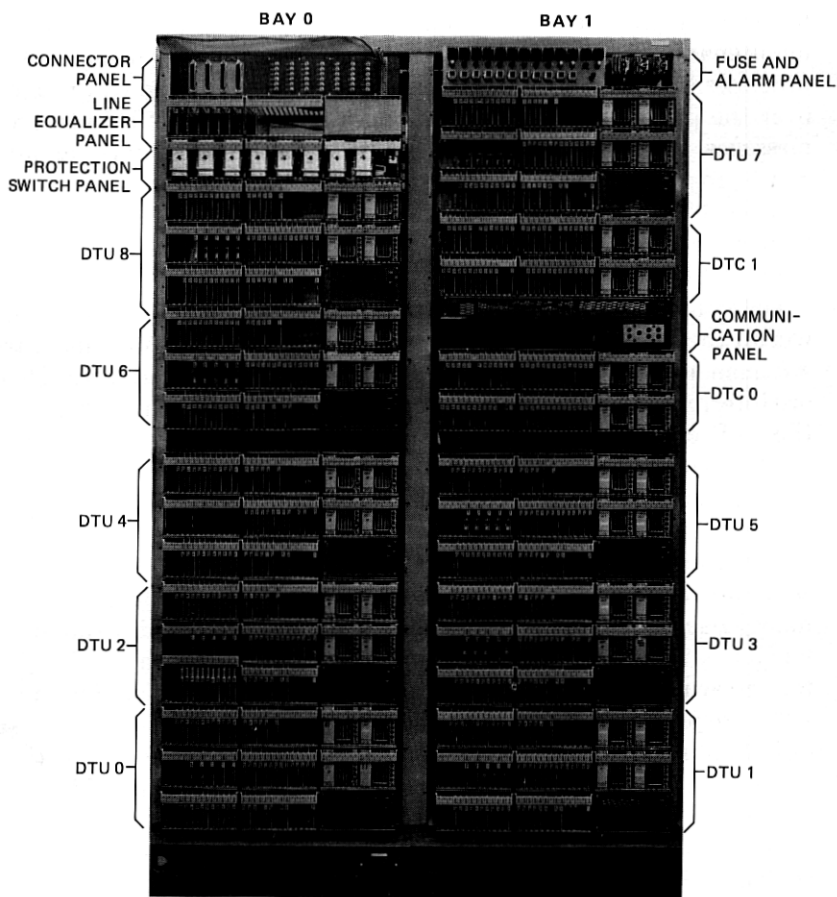

Fig. 3—Digroup terminal frame.

demultiplexing to interface the time-multiplexed 120-channel stream of the unit processor. The functions within the unit processor are sequentially performed on each digroup or channel in the multiplexed stream on a common-control basis. These functions include framing, signaling extraction and insertion, and digroup failure alarming.

Common control processing is important to the economic and maintenance objectives of the DT. In addition to allowing multiple digroups to share the logic associated with the digital processing functions, common control permits this circuitry to be functionally tested in real time. The result is an efficient processing structure for multiple digroups in which faults can be detected absolutely, with no circuit duplication required. Within the unit processor, the digital information is multiplexed in a time-slot format which is identical to that which exists within the time-slot interchange of the No. 4 ESS network.

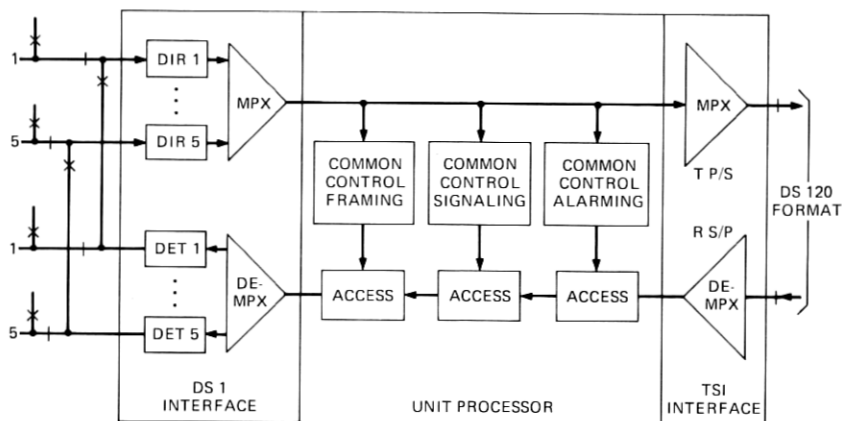

Fig. 4—DTU block diagram.

Within the DTU, the TSI interface performs the formatting and some additional multiplexing and demultiplexing to interface the TSI data port with the DS-120 format.

Figure 5 illustrates the data format at various points within the DTU. A single channel within a DS-1 level signal occupies $5.18 \mu\text{s}$ on a serial bipolar stream. Within the unit processor, a single channel is compressed to 976 ns in a parallel format, with each digroup compressed to $23.4 \mu\text{s}$ and stacked sequentially on the time-multiplexed stream. At the output of the TSI interface, the eight data bits of a single channel occupy 976 ns of an 8.192 Mb/s (16.384 megabaud) serial data stream.

3.2.1 DS-1 interface

The DS-1 interface receiver is shown in more detail in Fig. 6. In the incoming direction, the data stream is regenerated, monitored for bipolar violations, and converted to a parallel, word-organized format. The recovered clock drives digit and word counters which define the 24 channels. The word counter generates an address which is used to write the receive stores. Two 24 by 10 receive stores, designated the A store and the B store, are provided for each digroup, and these are written alternately with complete frames of data. The read address is provided by a decoding of DT clock with reads 24 channels from each digroup sequentially and stacks the digroups according to the time multiplexed format of Fig. 5.

The synchronization plan for No. 4 ESS requires that each incoming DS-1 level signal be frequency-locked to No. 4 ESS network clock. For trunks with DTs at both ends, frequency lock is ensured by the synchronization of No. 4 ESS network clocks. For trunks with a DT and a channel bank at opposite ends, frequency lock is achieved by loop timing

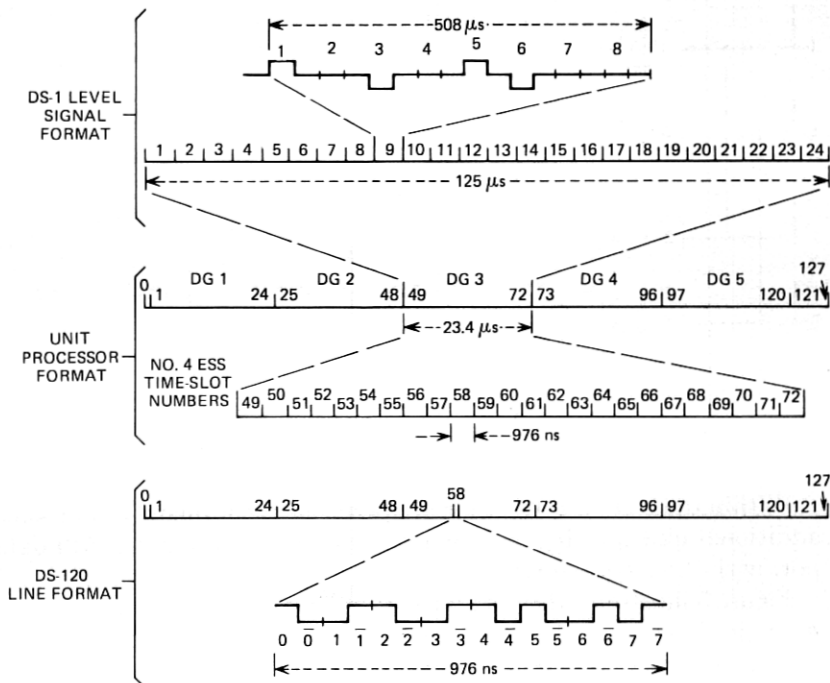

Fig. 5—DTU data formats.

of the interfacing channel banks. However, because of phase fluctuations on digital transmission lines or imperfect line-frequency synchronization, a slip occasionally occurs at the DTU. A slip for a digroup is defined as a deletion or repetition of exactly one frame of information for that digroup sent from the DTU to the No. 4 ESS time-division network. The direction of slip depends on the relationship between the No. 4 ESS and DS-1 level signal frame rates. Normally, the A and B stores are alternately read, but when an instantaneous difference between the No. 4 ESS and DS-1 level signal frame rates make an underflow or overflow imminent, the A store is read twice in succession. Depending on the relationship between office and line frame rates, this double read either deletes or repeats an entire frame of information for that digroup.

In the outgoing direction, A and B per-digroup stores are used to allow the 40 DT digroups to be aligned in phase. This permits direct comparison of outgoing frame and subframe bits which are common for all five digroups, thereby simplifying fault detection. For the transmit stores, the write address is provided by a decoding of DT clock which sequentially writes the 24 channels for each digroup according to the time-multiplexed format of Fig. 5. The read address is provided by a decoding of DT clock which establishes the outgoing-line word rate. In the outgoing

direction the A store is read while the B store is written and vice versa. Since write and read timing are phase and frequency locked, no slip is possible in the outgoing direction. The words read from the transmit stores are serialized, converted to bipolar format and transmitted as DS-1 level signals.

3.2.2 Unit processor

Each common control function is a sequential machine which consists of a recirculating memory and combinational logic to determine the next states and outputs from the present states and inputs. As data for each digroup appears on the time-multiplexed data stream, the state variables appropriate for that digroup are clocked to the output of the memory and new state variables are loaded into the memory input while output data is generated. In this way, the combinational logic processes each digroup sequentially, with the individual digroup states retained in memory. The result is a sharing of the combinational logic by all digroups, including test digroups, which leads to the significant maintenance advantages discussed in Section 3.4.

For incoming DS-1 level signals, detection of framing integrity is accomplished by examining the framing information in each digroup for the framing code. Once a digroup loses frame, hunting for the framing position is accomplished by examining data bits over several frames and searching for the framing code. Since each digroup is processed independently, any configuration of in-frame and out-of-frame digroups can occur, but all digroups are processed concurrently with the status of the individual digroups retained in memory.

In a similar manner, the common control signaling extraction function examines the incoming subframe information in each digroup for the subframe code, and it loads the signaling frame Digit 8 (D8) for all 24 channels into a recirculating 128-bit E-lead store.⁴ Signaling bits are extracted for each digroup independently in this way, but the signaling store is frozen for digroups which are out of frame or which have a mutilated subframe code.

The common control digroup failure alarm function monitors and times framing losses for local alarms and all zero incoming Digit 2's (D2) for remote alarms by incrementing and decrementing error-timing states.⁴ If the error-timing states are incremented past a threshold, the digroup is set to the local or remote alarm state. Similarly, removal of the alarm condition is timed by the error-timing states toward a threshold which results in the removal of the local or remote alarm state.

In the outgoing direction, the common control framing and signaling circuits insert framing bits, subframe bits and signaling frame D8 bits simultaneously for all digroups under control of DT clock. The signaling

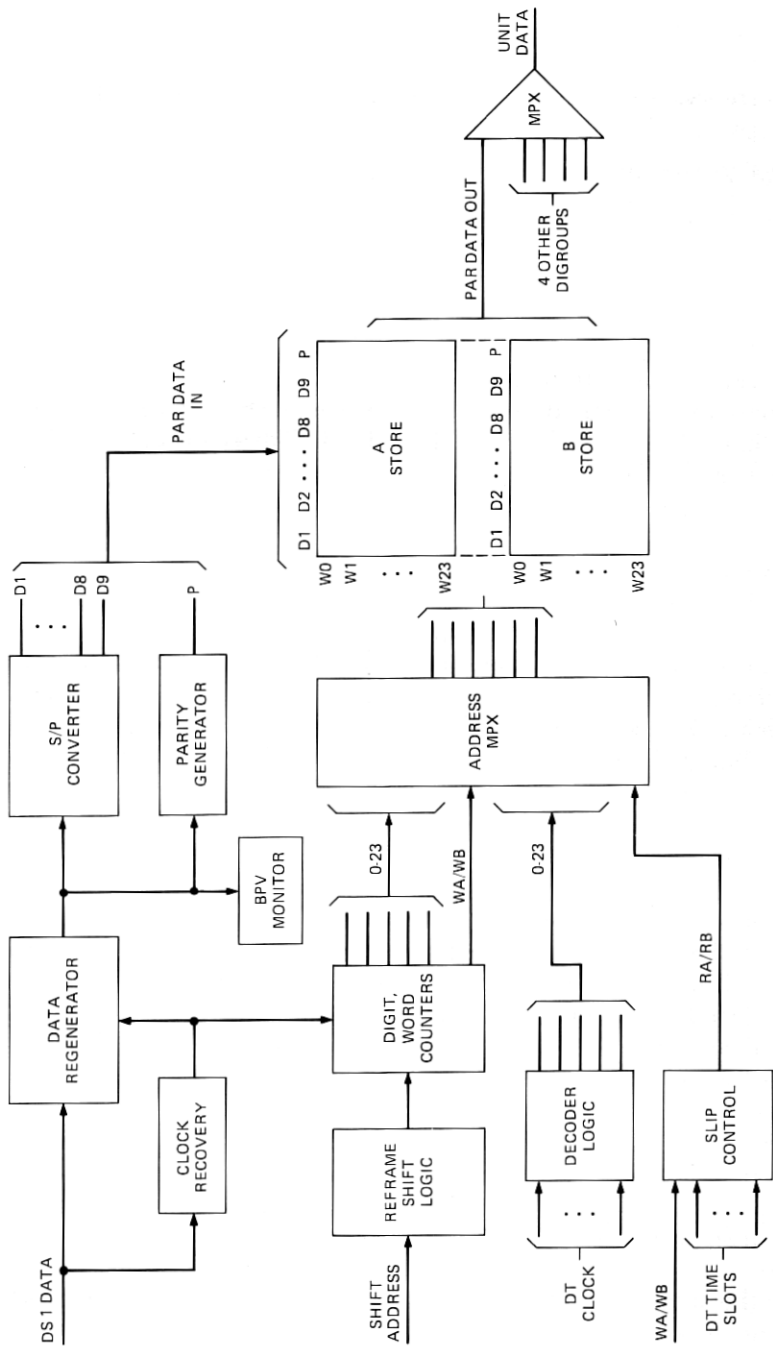

Fig. 6—DS-1 interface receiver.

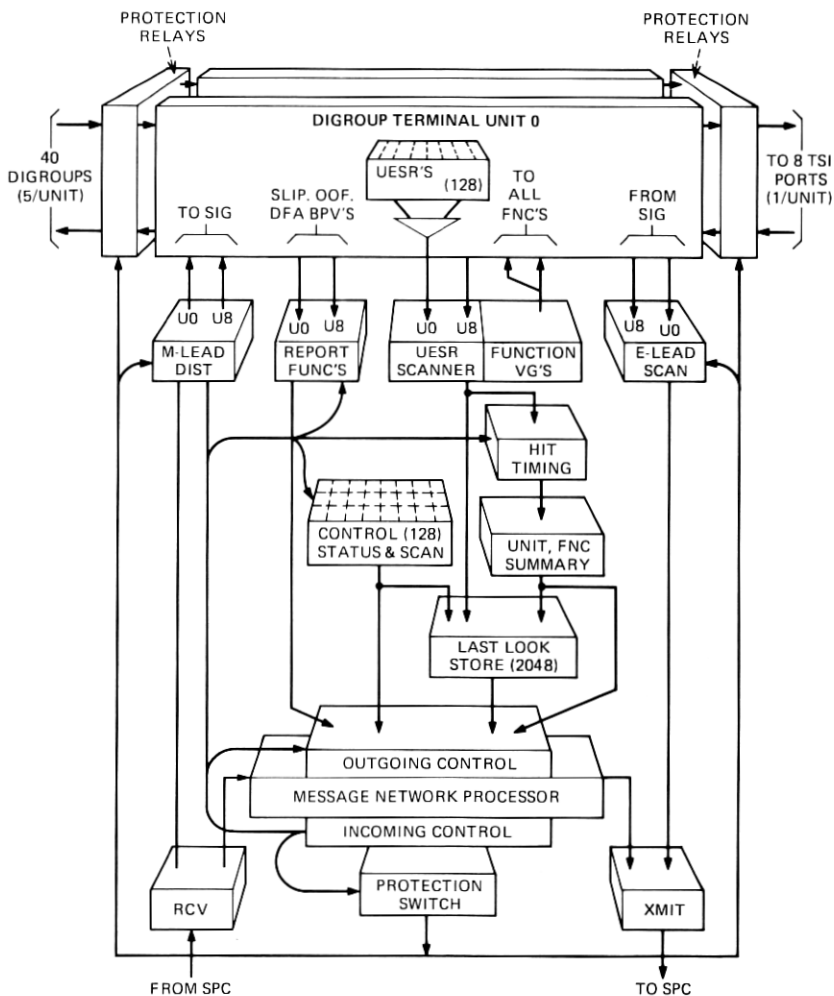

Fig. 7—Digroup terminal controller.

frame D8 bits are obtained from a recirculating 128-bit M-lead store which is updated periodically by SP2 via the DTCs. The common control digroup failure-alarm circuit also forces outgoing D2 bits low for digroups in local alarm.

3.3 Digroup Terminal Controllers

The DTCs are synchronous controllers that process signaling, supervision, and maintenance information on a serial time-division basis. Figure 7 shows a block diagram of the information processing hardware of a DTC. The controllers scan E-lead signaling bits from the individual

DTUs and send these bits to SP2 in a serial, high-speed stream. The controllers also receive a serial, high-speed M-lead stream from SP2 and provide the means to distribute this information to the individual DTUs. In addition, the controllers contain vector generators which exercise the functions of the DTUs. These vector generators are read-only memories which supply data bits for a test digroup and reference bits that constitute the expected results of the processing of these test data bits. The data bits are designed to exercise all single faults in the DTU functions, and deviations of the function outputs from the reference outputs constitute detected faults, which are loaded along with other alarms into DTU error-source registers. The controllers scan maintenance alarm information from the DTU error-source registers, hit-time the data, and summarize the alarms according to DTU and function. DTC alarms and status are also scanned, and all maintenance information is organized into a serial high-speed error-data stream at the last look store.

The controllers also provide the means to generate, queue, and distribute DT maintenance messages that pass between the DT and DT maintenance programs within the 1A Processor. These maintenance messages include autonomous and elicited alarm messages about the DT and about the T1 lines it terminates. T1 line report information is provided by the report function control which resides within the DTCs. The DTCs also provide the means to execute DTU protection switch orders which are sent from the DT maintenance programs in the 1A Processor.

3.3.1 Signaling exchanges with SP2

Signaling exchanges with SP2 are accomplished by multiplexing the E-lead information for eight DTUs into a serial stream, establishing a bidirectional high-speed communication link periodically with SP2, and demultiplexing the received M-lead stream to update the individual DTUs. DT clock organizes the E-lead bits into a continuous 1 Mb/s serial stream by scanning the 128-bit recirculating E-lead store of each DTU for 125 μ s. As shown in Fig. 8, each channel is assigned a specific 976-ns time slot, which occurs once every millisecond. Normally, the spare DTU is not scanned; however, when a DTU is protection-switched, the multiplex sequence is modified to insert the E-lead information from the spare DTU instead of that from the switched DTU. At the DTC transmitter, the signaling data bits are interleaved with address, opcode, and parity bits, as shown in Fig. 9, to establish a serial 2 Mb/s data stream between the DT and SP2. The address bits identify the location in SP2 memory into which the E-lead bits are to be written. The opcode bits identify the 32-bit word to SP2 as E-lead information, and the parity bit is used in DT/SP2 link maintenance.

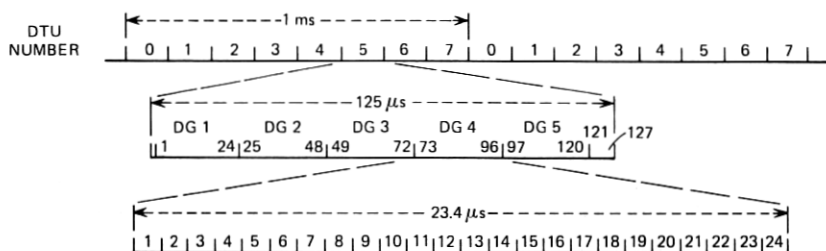

(a) SCANNED E AND M SIGNALING DATA FORMAT

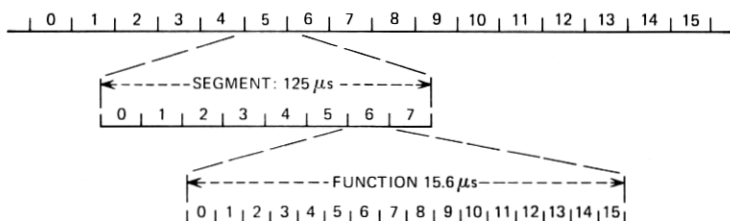

(b) SCANNED ERROR DATA STREAM FORMAT

Fig. 8—Time-slot assignment of signaling and maintenance data.

Normally, SP2 initiates a communication with each DT once every 10 milliseconds. Once SP2 is synchronized to the DT, rows of SP2 scan memory are written with 16 bits of data using the addresses which were interleaved with the data bits. In addition, SP2 signal-distribute memory is read to gather rows of 16 bits of data to be sent to the DT. The address used for the read operation is the address used for writing, but it is modified to account for the processing delay of the SP2, so that the SP2

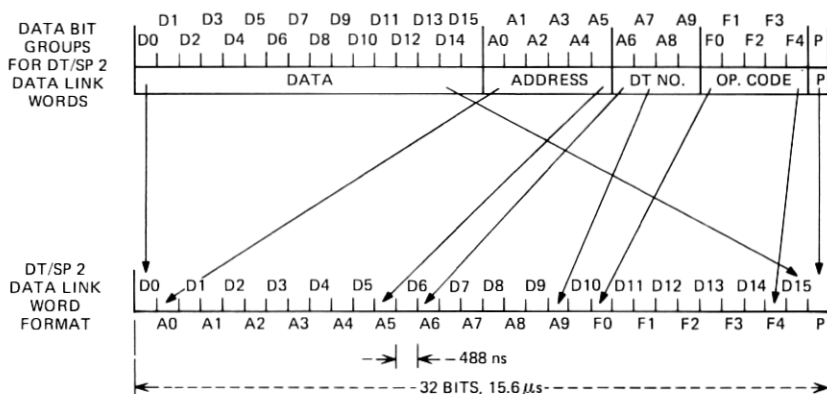

Fig. 9—Data link word format.

to DT word always has the same address as the word traveling in the reverse direction. The opcode bits identify this SP2 to DT word as M-lead information, and the parity bit is added for link maintenance. The SP2 stores the address of the initial E-lead word and terminates the communication when this address is reencountered.

At the DT receiver, the received M-lead words are by design already synchronized with DT clock in both frequency and phase. The DT receiver checks the words for proper DT number, address, and parity. If the opcode indicates M-lead data, DT clock distributes the data bits serially, in real time, to the M-lead store of the DTU indicated by the address. When a DTU is protection-switched, the demultiplex sequence of Fig. 8 is modified to load the M-lead store of the spare DTU instead of that of the switched DTU.

3.3.2 DT error-data stream

The processing of DT failure information and maintenance messages is similar to the processing of signaling. As shown in Fig. 7, maintenance data from the alarms within the DTU are collected into error-source registers (ESRs) located in the unit processor. DTU clock organizes the alarm bits into a serial stream by scanning 128 ESR positions in 125 μ s. DTC clock scans these DTU alarm streams with a 2-ms cycle, as shown in Fig. 8. Each 125- μ s portion of the cycle is designated a segment, and alarms from DTU0 through DTU8 occupy segments 0 through 8 on the error-data stream. Each of the 8 groups of 16 bits within a segment is designated a function, and each function physically corresponds to a 16-bit ESR in the DTU. The basic DTU alarm bits are hit-timed by the DTC; that is, a failure must be present during three 32-ms periods out of eight such periods in order to be considered a hard failure. The purpose of this hit-timing is to eliminate No. 4 ESS maintenance activity due to transmission phenomena such as noise bursts or loss of data on incoming DS-1 level signals and DTU protection switches. The hit-timed DTU failure information is summarized and inserted into segment 15 on the error-data stream. Thus, if a DTU alarm persists longer than the hit-timing interval, the unit summary indicates the failing DTU.

In a similar manner, DTC status bits and alarms are scanned and inserted into the error-data stream in segment 13 and 14, respectively. The DTC alarm information in segment 14 is summarized by function as shown in Fig. 8. The error-data stream is held in a 2048-bit recirculating last look store which provides all health and status information of the DT.

The processing of DS-1 level signal degradations is performed in an analogous manner. As shown in Fig. 7, bipolar violation samples, slip occurrences, framing state, and remote and local alarm state emerge from the DTUs in serial streams which are further scanned and processed in

report function control. Report function control occupies functions six and seven in segment 12 on the error data stream.

3.3.3 DT maintenance messages

The generation and distribution of maintenance messages is controlled by the message network. Of the outgoing messages, only the DTU summary, DTC summary, and report function messages can be generated autonomously; all others must be requested by DT maintenance software, which is resident within the 1A processor. Outgoing messages are queued in a 128-bit recirculating message-request store. Each bit of the message-request store corresponds to a 16-bit function on the error-data stream, and a logical 1 appearing at the message request store output can gate 16 bits from the error-data stream directly into the message network. Detectors monitor the input and output of the last look store and load the message-request store during segments 14 and 15 if changes are detected. Similarly, the message request store is loaded when DT clock matches the segment and function identifier accompanying a single or multiple message request received by the message network from DT maintenance software. Scanning for new outgoing messages always ensures that DTC status messages, DTC alarm messages, DTU alarm messages, and report function messages are assigned decreasing priority.

Within the message network, the 16 outgoing message data bits are concatenated with a 16-bit message identifier, and the resulting 32 bits are sent to the DTC transmitter where they are formatted into two words of the form of Fig. 9. The opcode bits identify the resulting DT/SP2 link word as message-half one or two and as having high or low priority. The priority of DT messages is strictly a function of the processing time requirements for the message. The messages ultimately reach DT maintenance software via the SP2 high- or low-priority buffers which have nominal unloading times of 10 and 100 ms, respectively. When SP2 initiates a communication with the DT, a DT maintenance message or an idle message is concatenated with the signaling exchange as additional DT/SP2 link words. The outgoing DT maintenance message is loaded into the SP2 high- or low-priority buffer, depending on the link opcodes. The opcodes are retained within these buffers, and when the buffers are unloaded, the message is sent to DT maintenance programs resident in the 1A Processor. In the reverse direction, DT maintenance software loads DT maintenance messages into a special SP2 buffer for subsequent transmission to the DT. At the DT, an incoming DT maintenance message is loaded into the message network and the 16 data bits are distributed to the specified function during the next full 2-ms DT clock cycle. Each incoming message is distributed during a specific time slot or set of time slots during the distribution cycle. After the distribute cycle is complete, the message network scans for new outgoing messages.

3.4 Maintenance

Detection of service-affecting faults is autonomous within a DT, and such failures result in the autonomous generation of DTC or DTU failure summaries. These are interpreted by the DT fault-recovery program and the faulty subsystem is isolated by reconfiguring the DTCs or DTUs in time to preserve the existing calls. The DT diagnostic program is later executed to resolve the failure to a small set of circuit modules. The diagnostic program also searches for latent faults within the DT and is scheduled periodically in addition to responding to detected faults.

3.4.1 Fault Detection

Within a DTU, parity and hardware test vector techniques are used to detect service-affecting faults. Within the DS-1 interface, parity over address plus data is generated and carried along with the data in both directions of transmission. In addition, common signals in the outgoing direction, such as subframe and framing codes, are compared in appropriate time slots to reference signals. Within the unit processor and TSI interface, test vectors are inserted in spare time slots to exercise the processing functions, and the function outputs are compared to reference vectors, which constitute the expected results. As shown in Fig. 5, time slots 0 and 121 through 127 of the time-multiplexed data stream are not assigned to active digroups. Instead, these eight time slots constitute a short test digroup which receives data bits and control inputs from vector generators within the DTC. These vector generators are read-only memories which are addressed by DT clock. The contents of the ROMs are designed to exercise completely the service-affecting single faults of the processing functions. The outputs of the processing functions are compared in the test digroup time slots to reference vector inputs from the DTC.

These fault-detection techniques are extended to the processing functions of the DTCs. Segment 9 of the error-data stream contains test vectors used to exercise the error-data-stream processing circuitry. In addition, test vectors are applied to the receiver, message network, report functions, and other DTC functions during appropriate portions of the operating cycle. Outputs from the functions are compared to expected results in these spare time slots to detect service-affecting DTC faults.

3.4.2 Fault recovery

When a service-affecting DTU fault occurs, the DTU error-source registers are loaded with an alarm pattern. This ESR data is hit-timed in the DTCs, and a DTU failure summary is sent to the DT fault-recovery program in the 1A Processor. The DT fault-recovery program interprets the failure summary and sends a DTU protection switch request message

to the DT. The DT message network distributes the message to the protection switch control which switches the spare DTU into the position of the failed DTU, thereby completing fault-recovery action.

When a service-affecting DTC fault occurs, the DTC error-source registers are loaded with an alarm pattern, and a DTC failure summary is sent to DT fault recovery programs. These programs interpret the failure summary, perform software hit timing and send configuration request messages to the DT to configure to the healthy DTC. The message network distributes these messages to the DTC status bits which configure the frame to the requested controller, thereby completing fault-recovery action. When DTU or DTC fault recovery action is completed, a DT diagnostic program is scheduled.

3.4.3 Fault diagnosis

The DT diagnostic program elicits and collects DT ESR information by sending single and multiple message requests to the DT and then maps these ESR alarm patterns into a small set of circuit modules. The diagnostic program also detects latent faults by inverting parity checks and comparator inputs and observing the maintenance system's ability to detect and report faults. The diagnostic also exercises the various DT configurations.

3.4.4 DS-1 level signal degradations

Sixteen bit messages that report degradations on the incoming DS-1 level signals are generated by report function control and sent to the message network. Within the message network, these 16 data bits are concatenated with a 16-bit message identifier, and the resulting 32 bits are sent to the transmitter where they are formatted as a pair of DT/SP2 link words. Two kinds of report messages can be sent for each digroup. The first contains digroup status, such as remote and local alarm state, framing state, and slip state. The second contains a bipolar violation measurement. A digroup status message is loaded into the outgoing message queue on slip occurrence, framing loss occurrence, remote or local alarm state change or on request. A bipolar violation message is loaded if the bipolar sample indicates a sample bipolar violation rate exceeding 10^{-6} violations per bit or on request.

The report messages are sent to the 1A Processor resident DT maintenance programs. These programs record digroup local and remote alarm status and remove trunks from service under alarm conditions. In addition, slip rates, framing loss rates and bipolar violation rates are computed. If the rate computation indicates that the maintenance or out-of-service limit for that digroup is exceeded, the facility craft are notified via CMS-1A.⁵

IV. VOICEBAND INTERFACE

4.1 Frame overview

4.1.1 Function

The Voiceband Interface (VIF) is the standard interface for voice-frequency circuits in No. 4 ESS. A VIF terminates 840 four-wire analog trunks. Typical terminations are analog carrier trunks, metallic trunks, and service circuits. The principal functions of the VIF are analog-to-digital and digital-to-analog conversion of voice-frequency circuits, and formatting of the digital data to be switched by the time-division network.

The VIF consists of seven service Voiceband Interface Units (VIUs), a switchable spare VIU, and a duplicated maintenance controller (VIC). Each service VIU terminates 120 analog trunks and interfaces with the time-slot interchange (TSI) by a pair of coaxial cables using the standard DS-120 digital format.

The overall VIF structure is illustrated in Fig. 10. The VIUs convert voiceband signals to properly formatted digital streams in one transmission direction and reconstruct voiceband signals from digital streams in the opposite direction of transmission. Processor access to the VIF is provided by the Peripheral Unit Bus System, partially via the signal processor. The VIC controls the protection switching relays and provides timing, control, and maintenance functions for the VIUs.

4.1.2 Physical characteristics

The VIF equipment is contained in a triple-bay, 6-foot, 6-inch wide by 7-foot high frame (Fig. 11). The major components are the eight VIUs and a pair of controllers (VICs). Each VIU is a three-shelf, 18-inch high assembly including power converters. The two VICs including power converters are housed in a four-shelf 22-inch high assembly in the middle bay. Voice-frequency and PCM switching relays used to configure the spare VIU in place of any of the service VIUs are housed in the top two shelves, 14 inches high, of each bay. Connectorized cabling is used for voice frequency, PCM, and processor interfaces.

4.1.3 Technology

VIF circuit functions that are primarily digital use standard 1A Technology³ circuit packs, multilayer back-planes, and wiring. The maintenance controller uses this technology exclusively. However, a large portion of the VIU functions are analog, which leads to use of a mixture of technologies. 1A Technology is used for digital functions and a combination of hybrid integrated circuits and discrete components mounted on epoxy boards is used for the inherently analog circuitry. An example

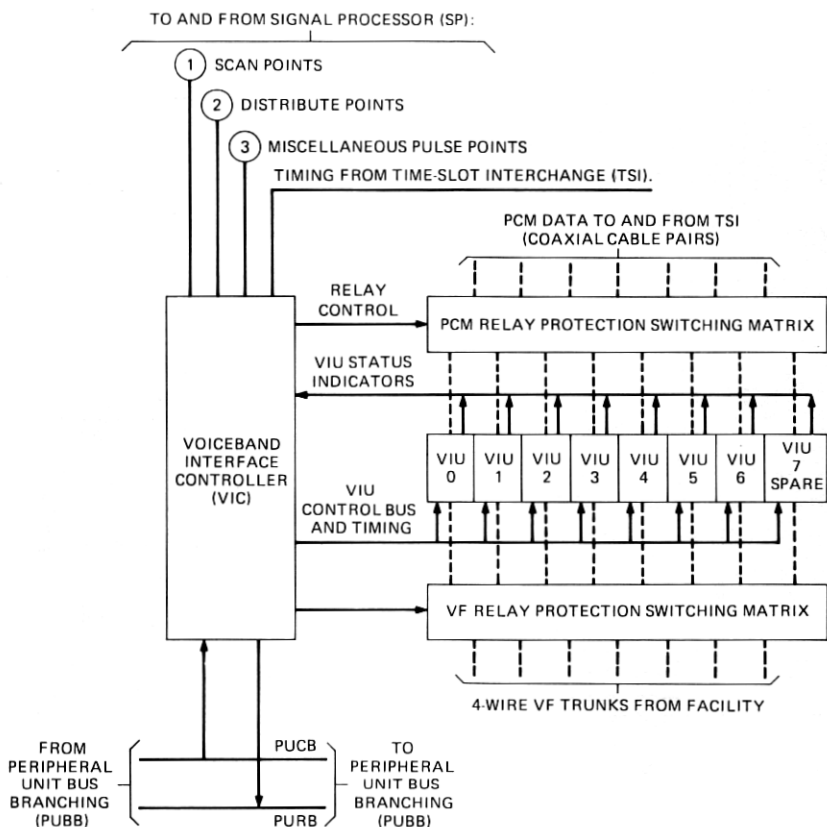

Fig. 10—Voiceband interface block diagram.

is illustrated in Fig. 12. This circuit pack performs the functions of filtering, sampling and PAM multiplexing for eight voice-frequency circuits. Filtering is provided by individual thin-film resistor-capacitor active filters. Sampling and multiplexing are performed on a bilevel ceramic (conductor paths on both surfaces interconnected by plated-through "vias") using beam-leaded silicon devices. Other analog functions use bilevel ceramics with thin-film resistors, applied chip capacitors and beam-leaded silicon devices.

4.2 Voiceband Interface Unit

4.2.1 VIU functions

A block diagram of the VIU is shown in Fig. 13. In the transmitting direction, the 120 trunks used for traffic and the eight trunks used for testing and maintenance purposes have low-pass filters at their inputs.

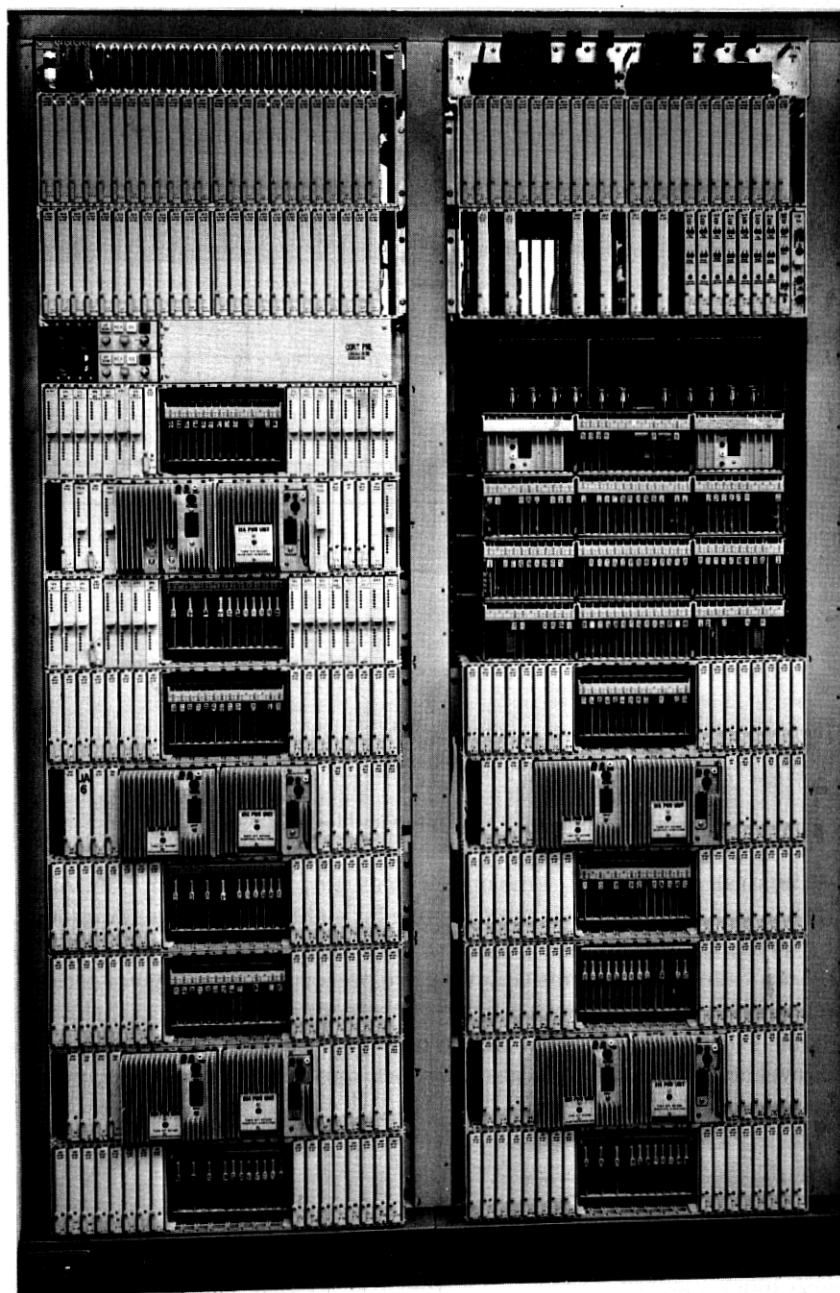

Fig. 11—Two bays of the voiceband interface equipment frame.

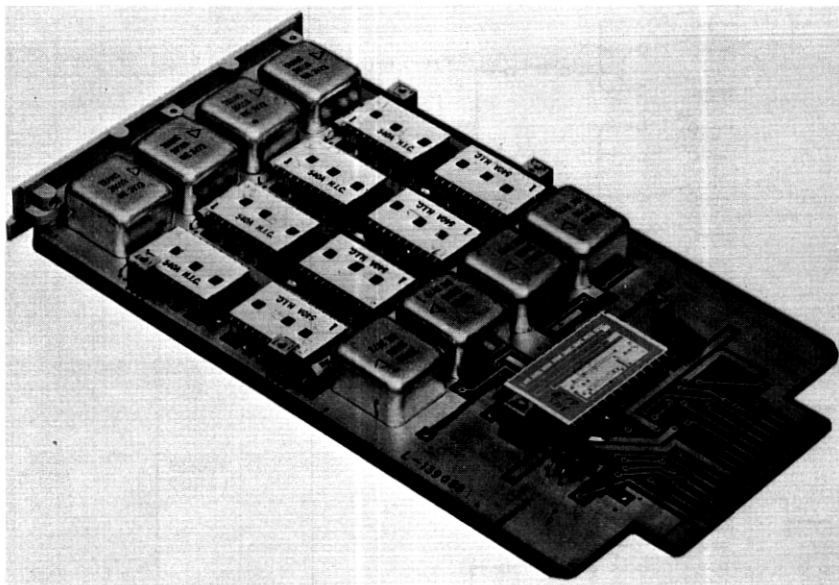

Fig. 12—VIU analog circuit pack.

These filters band-limit the input signals to less than 4 kHz to prevent foldover distortion. That type of distortion would otherwise be introduced by the 8-kHz sampling associated with PCM encoding.

The VIU uses two stages of multiplexing. In the first stage, all trunks are sampled at an 8-kHz rate and multiplexed onto four buses of 32 trunks each. Each of these buses contains samples for 30 service trunks and two maintenance trunks. At this point, the samples from the trunks are natural Pulse Amplitude Modulation (PAM) samples approximately 3 μ s in duration. In the second state of multiplexing, each pair of the 32-trunk buses is combined into a 64-trunk PAM bus. Each sample on the PAM bus is approximately 2 μ s in duration.

A coder performs A-to-D conversion for each 64-trunk PAM bus. The coders use a nonlinear 15-segment μ -law encoding characteristic and code each PAM sample into an 8-bit PCM word. One bit is used as a polarity indicator, and the remaining seven are used to represent the amplitude of the sample. A coder output PCM (COP) circuit gates the parallel PCM words coming out of the two coders to the access circuit, one at a time. Each PCM code word exists in parallel form at the access for 976 ns, which is one PCM word time slot. The access circuit plays an important role in VIU maintenance, as described in Section 4.4.2.

Data from the VIU is sent, via the 16.384-megabaud coaxial line, to the TSI. Transmitters and receivers are used in both the VIU and the TSI to convert back and forth between parallel PCM data and the serial

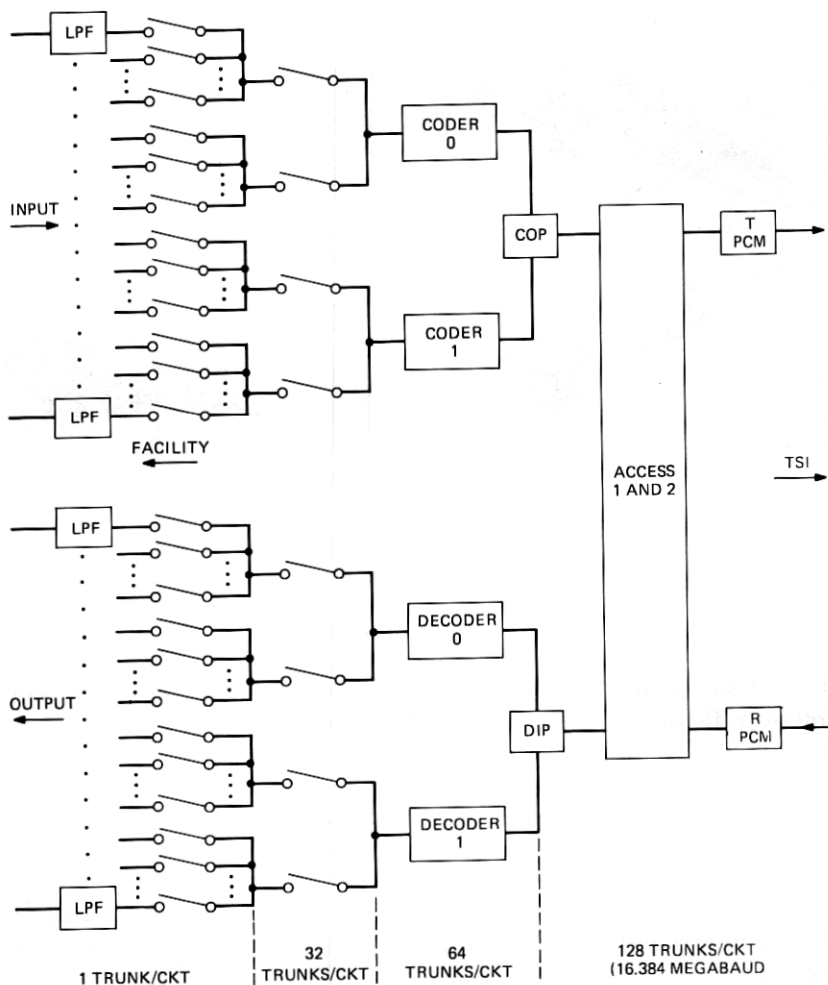

Fig. 13—Voiceband interface unit block diagram.

16.384-megabaud format and to derive local timing and framing information. The transmitter in the VIU converts the parallel PCM words from the access into a serial form containing timing and framing information, constructing the DS-120 signal. The transmission is over coaxial cable to the receiver in the TSI.

The receiver section of the VIU accepts the DS-120 signal coming from the TSI, extracts local data timing, regenerates the data pulses, and formats the incoming data back into parallel PCM data words. Buffer stores are used to realign incoming data words with timing supplied from the VIC.

PCM words pass through the access to the decoder input PCM (DIP)

circuit, which routes them alternately to one of two decoders. Each decoder is used for 64 trunks. The 64-trunk PAM buses are demultiplexed into four 32-trunk PAM buses and then into single trunks. Low-pass filters reconstruct the voiceband (up to 4 kHz) from the demultiplexed PAM signal.

4.2.2 Transmission characteristics

A-to-D and D-to-A conversions in the VIF use the Bell System standard 8-digit, 15-segment, $\mu = 255$ coding characteristic. Transmission characteristics are compatible with and virtually identical to those of digital channel banks that use that coding characteristic.⁶ Thus, an analog trunk terminating on a VIF can be switched to a digroup terminal, transmitted over a T1 line and ultimately terminate on a digital channel bank.

All analog terminations on VIF are four-wire with a nominal -3 transmission level (TL). This interface is not defined as a standard point; it is permitted to vary by a few tenths of a dB. Variation of this level, office cabling loss, etc., are compensated for by loss-adjustment pads in the interfacing terminal equipment to provide the appropriate standard levels in these terminal equipments.

4.3 Voiceband Interface Controller

4.3.1 Functions

The primary functions of the VIC are to provide timing, control, and maintenance signals to the VIUs, to monitor the status or health of the units, and to control VIU protection switching. Most controller circuitry is fully duplicated for increased reliability and fault detection capability, and either controller can perform the required functions.

Timing is derived from duplicated master timing links provided by the TSI. This timing information is used to derive clock waveforms for use by the controller. The derived clock waveforms are distributed to the units on a clock bus from each controller. The units are configured to use the appropriate clock bus.

Various analog and digital maintenance signals are also derived in the VIC and distributed to the units. These signals are used to detect and isolate failures in a unit. The status of the units is monitored by sampling 22 indicators from each unit. When one or more of the status indicators report a failure in a unit, the VIC reports the failure to maintenance software residing in the 1A Processor, and the spare unit is protection-switched to provide service continuity.

4.3.2 Controller-processor interfaces

Processor orders are sent to the VIC through duplicated 16-bit SP pulse point buses. Either SP bus sends the orders to both controllers.

Responses from the controller are sent as 16-bit words plus parity over the PURB. The controllers can be configured such that either VIC can respond on either reply bus. In addition, the PUCB is used for failure reporting. The 1A Processor periodically interrogates the controllers, which respond if failures exist.

4.4 Maintenance plan

4.4.1 Controller maintenance

Controller hardware faults are detected autonomously by unique indicators in each controller half, such as parity, or by mismatches between duplicated controller functions. If one of these indicators records a failure, an interrupt is generated and fault-recovery software removes the suspect controller from service and schedules a diagnostic of the controller to isolate the source of the fault. However, since the VIC is a maintenance controller and serves no real-time, call-processing-related function, a large percentage of circuitry is exercised only during diagnostics. Thus, latent, non-service-affecting faults can exist that are stimulated and detected only by the diagnostic. Consequently, a diagnostic is run periodically even when there is no indication of failure.

4.4.2 Unit maintenance

Each controller monitors 22 status indicators for each VIU. These indicators include parity failures, power converter failures and out-of-limits signal or distortion levels in maintenance trunks. When an indicator records failure in a service VIU, the spare unit is protection-switched to provide service continuity, and the unit diagnostic is scheduled.

(i) *Signal and distortion monitoring.* Each 32-trunk PAM bus (Section 4.2.1) contains two trunks that do not carry traffic. One of these trunks for each bus is dedicated to full-time signal and distortion monitoring. A sinusoidal maintenance signal supplied by the VIC is applied to each of these trunks. The maintenance signal continuously cycles through four amplitudes at a low frequency rate. These maintenance trunks are sampled, multiplexed and coded in the same manner and by the same circuitry as service trunks. Internal timing of the VIU is arranged such that when any time slot, say N , appears at the access to be transmitted to the TSI, the same time slot received from the TSI also appears at the access. Thus, there is "time-slot alignment" of PCM data words at the access. This time-slot alignment permits looping the four maintenance trunks from COP to DIP through the access. These maintenance trunks are then decoded and demultiplexed to baseband.

The signal amplitude of each of these maintenance trunks is monitored and the distortion is measured. In the event the signal amplitude or

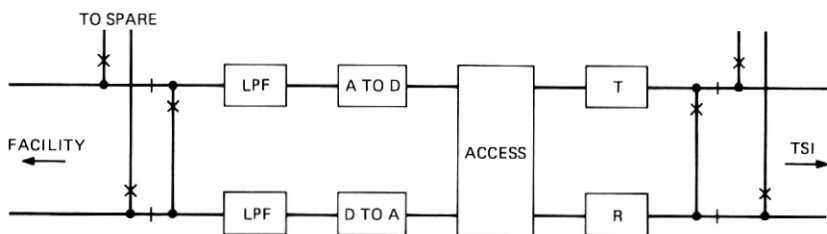

Fig. 14—Trunk looping in maintenance position.

distortion limits are not met, status indicators monitored by the VIC indicate a failure. These indicators detect failures of equipment common to 32 or more trunks.

(ii) *Time-slot exchange.* The unit diagnostic is run on the spare VIU only when it is in the nonservice position or on a service unit when it is protection-switched. When in this maintenance position, all 120 trunks are looped at voice frequency and PCM as shown in Fig. 14. Storage registers in the access can be used to perform a "time-slot exchange" as follows. Coded PCM words from one of the maintenance trunks are stored in a register in the access. This word can then be written in place of the data for any trunk, say N . The data are then decoded and demultiplexed in trunk N , looped back to the input of trunk N , and stored in another register in the access. They then are written into another maintenance time slot and decoded, demultiplexed, and tested by the maintenance signal monitor. This provides the ability to locate failures of per-trunk equipment such as filters and multiplexing gates.

V. TOLL TERMINAL EQUIPMENT INTERCONNECTION

5.1 Frame interconnection characteristics

The voiceband interface frame establishes a well defined and standardized transmission interface between the No. 4 ESS switch and analog transmission facilities. Similarly, the Signal Processor 1 establishes a well defined and standardized signaling interface between the No. 4 ESS and analog transmission facilities. Together, the VIF and SP functionally eliminate the need for trunk circuits. Trunk circuits traditionally functioned to match the various types of transmission facilities, with their variety of signaling methods, with the service characteristics of the trunk and the signaling methods used within the switching system. In No. 4 ESS, all types of analog transmission facilities interface the VIF and SP1 in exactly the same way. This standardized interface and the modular design of both the VIF and SP1 grant the design freedom to distribute them as required to optimize floor-plan arrangements.

Digital transmission facility interfaces with the switching system are more drastically affected by the development of the Digroup Terminal.

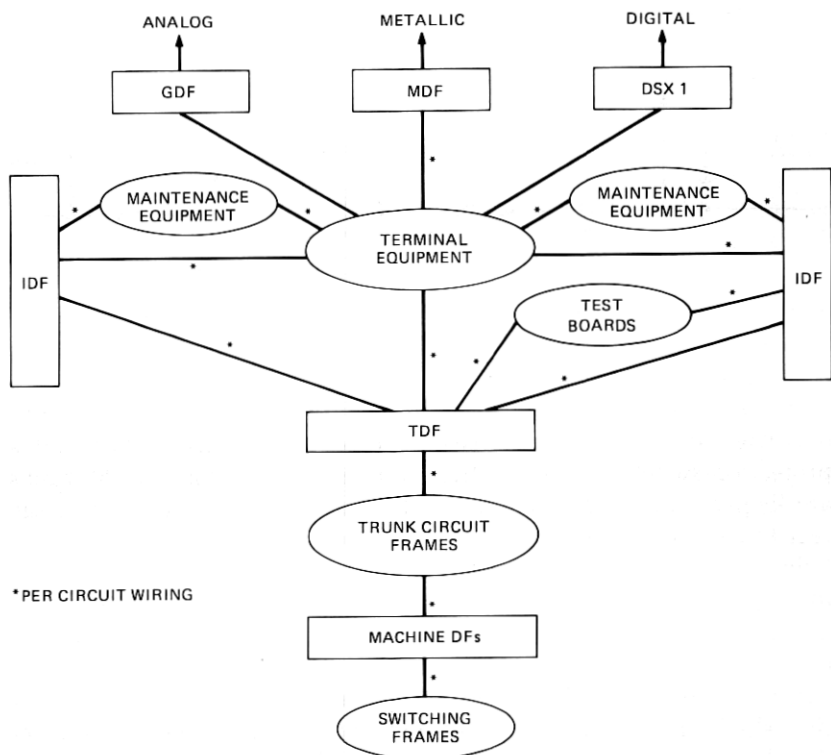

Fig. 15—Typical machine cabling.

Where digital facilities previously had to be converted to individual voice-frequency analog channels to interface trunk circuits, the digital signals can now be processed by the DT to enter the switching system directly as a digital bit stream. Signaling information, as previously described, is extracted by the DT and passed to the Signal Processor 2, also in digital form. This drastically simplifies the signaling interface and interconnection.

Perspective on how the characteristics of the No. 4 ESS with standardized DT, VIF and SP interfaces can be exploited to substantially improve office interconnection may be gained by considering a typical existing electromechanical toll switching system. As indicated in Figure 15, multiple Distributing Frames (DF) are used to cross-connect individual pieces of terminal equipment (channel banks, signaling units, attenuators, repeaters, analog echo suppressors, etc.) and maintenance equipment [toll testboards (TTB) with dedicated jacks, VF patching bays, etc.] to form the required variety of trunk types. The asterisks indicate that almost all cabling is on multilead, per-circuit (trunk) basis, equating to near astronomical numbers of wires for a system using the full capacity

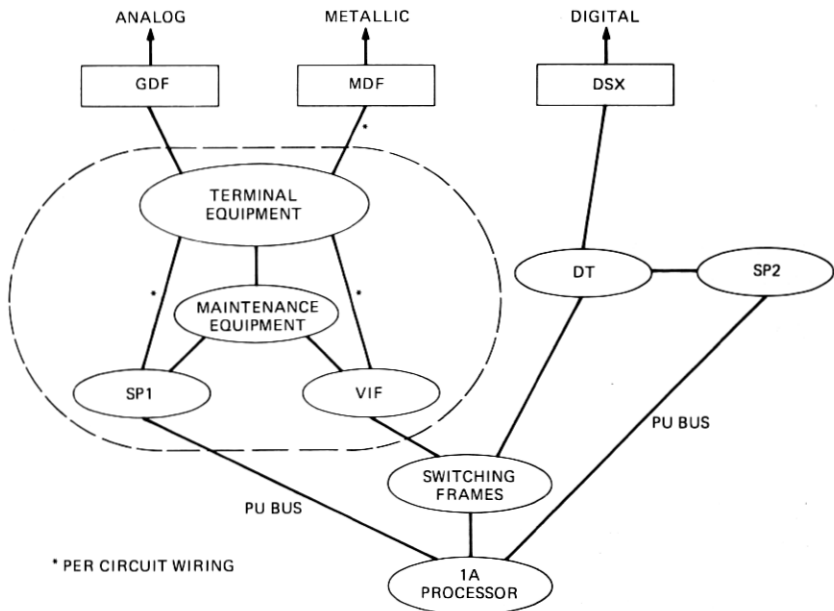

Fig. 16—No. 4 ESS cabling.

of No. 4 ESS. For simplicity in presentation, the terminal equipment is shown as a single entity. In reality it is scattered throughout the building, often on several floors, and several IDFs (Intermediate Distributing Frames) may be required to provide all the necessary terminations. When the terminal and maintenance equipment is properly interconnected by multiple DF cross-connects, the equipment connects via the trunk distributing frame (TDF) (sometimes called a machine IDF) to the trunk relay circuits. These are again cross-connected to the variety of switching frames composing the switching system. These DFs, in addition to permitting proper interconnection of the variety of trunk relay circuits with the variety of facilities and terminal equipment, permit traffic-load balancing on the switching frames.

In contrast, Fig. 16 illustrates interconnection within the No. 4 ESS. As will be discussed further, all distributing frames except the basic facility interfaces—Group Distributing Frame (GDF), Main Distributing Frame (MDF), and the Digital Signal Cross-connect frame (DSX-1)—have been eliminated. For digital trunks, all per-circuit wiring has been eliminated. All per-circuit wiring also has been eliminated between the switching frames (TSI, TMS, 1A Processor) and the analog terminal core indicated by the dashed oval. Although, individual per-circuit wiring could not be eliminated within this core, it has been simplified by the use of connectorization and reduced by a modular floor plan layout.

Much of the total wiring is performed at the factory using the facility terminal concept where the maintenance access equipment is built into the equipment frame together with all the circuit elements required for a working trunk. The basic cabling plan is diagrammed in Fig. 17, including interconnection of existing equipment where the No. 4 ESS replaces a No. 4A crossbar system.

The following paragraphs will describe how these new interfaces and new equipment were used to optimize interconnection of toll terminal equipment in the No. 4 ESS environment.

5.1.1 Analog facility terminals

The concept of unitization (combining needed circuit elements in a single package) was well developed when the No. 4 ESS design was started. In fact, analog carrier unitized facility terminals which functionally provide the needed No. 4 ESS interface were developed for application in crossbar switching systems. The existing designs, however, did not fully exploit the interconnection characteristics of No. 4 ESS.

The standard interface and the nonblocking characteristics of the switch suggested elimination of the traditional distributing frame with its administrative and daily operational problems. Elimination of the distributing frame in turn suggested that connectorization be applied to the cables between the Unitized Facility Terminals (UFT) and the VIF and SP1. Connectorization could be applied readily to either end but would not be nearly as effective in reducing installation time and expense as would applying full connectorization. To achieve double-ended connectorization, a floor-plan arrangement would be needed that could be restricted and confined in terms of cable length and routing. Connector cables tend to be expensive if they cannot be produced in large quantities. Therefore it was essential that the connectorization plan require only a small number of distinct cable designs.

Once it was established that a suitable floor location and connectorization plan were feasible, the UFT was designed for connectorization in conjunction with the designs of the VIF and SP1.

Figure 18 shows a typical UFT design. All connectors are conveniently located at the top of the frame. Included in the frame are: the channel bank multiplex and demultiplex equipment to translate between individual VF channels and carrier channel groups, Single-Frequency (SF) signaling equipment to translate between line tone signals and standard dc unidirectional signals called E and M (signals toward the switch are carried on E leads and signals toward the facility are carried on M leads), attenuators to establish standard transmission levels, maintenance access equipment to permit testing at standardized transmission and signaling reference points, communications equipment to allow craftspeople to communicate with other craft and testers, patching equipment

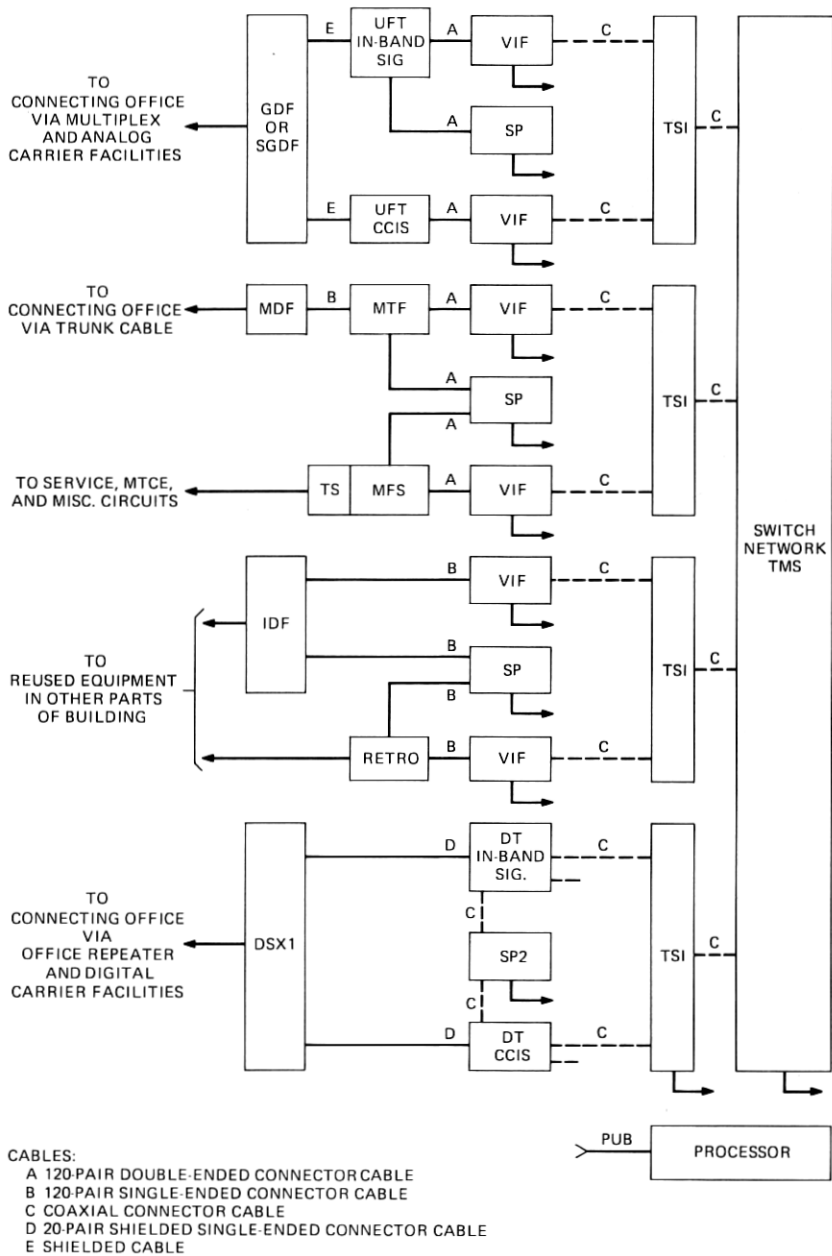

Fig. 17—Basic cabling plan.

to permit emergency restoration of failed facilities; and equipment common to all 96 circuits on the frame or the 480 circuits composing a standard frame set. Common equipment items are carrier frequency

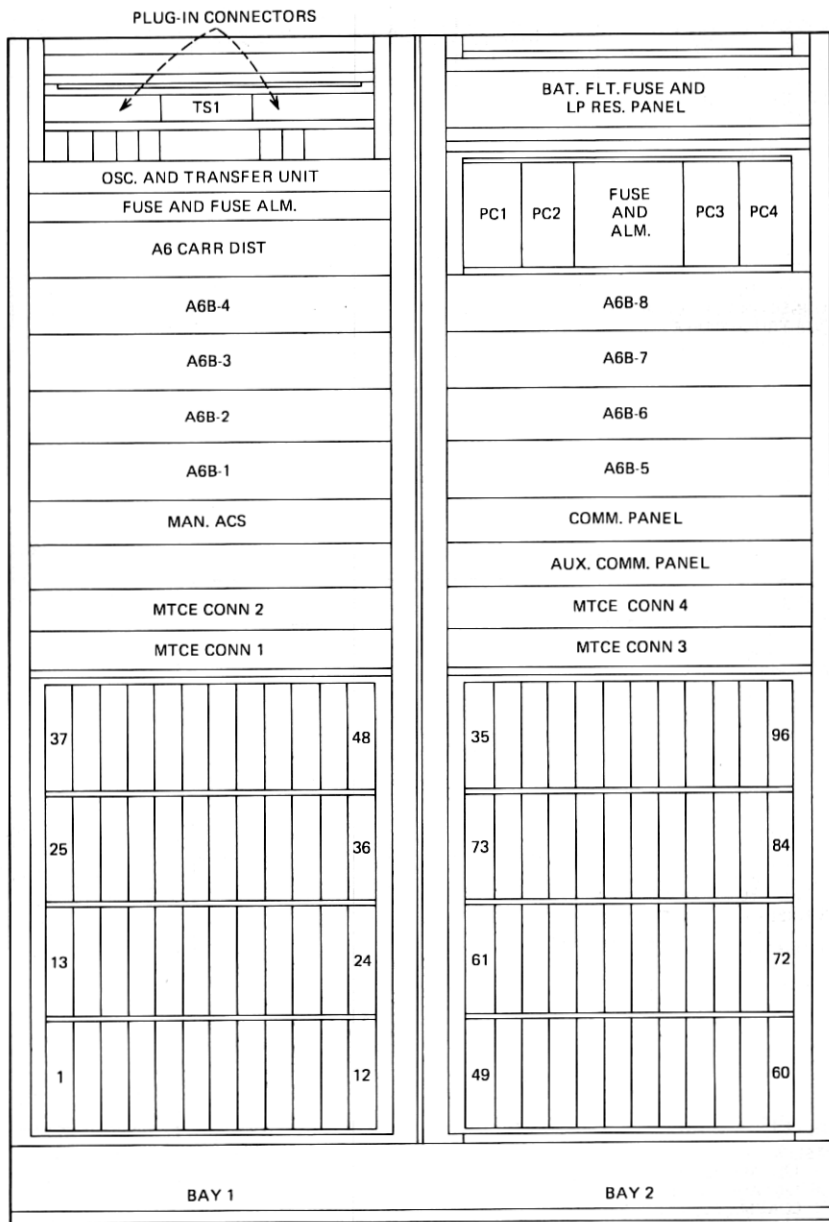

Fig. 18—Typical unitized facility terminal.

supply and distribution, SF tone supply, power, and fuse and alarm units.

A family of UFTs for analog carrier facilities has evolved to provide

needed features and characteristics economically. One member of the family will be used with trunks requiring in-band single-frequency signaling. This frame may also be used for trunks using Common Channel Interoffice Signaling (CCIS) by substituting a plug-in unit providing only an attenuator function for the signaling unit plug-in. It is substantially more economical, however, to use a second-type frame designed specifically for CCIS. The use of the first frame for temporary use on CCIS trunks will be useful as an expedient to transfer trunks from in-band signaling to CCIS as the CCIS network expands.

The frames are arranged to provide a number of features or capabilities on an optional basis. They may be arranged to interface the multiplex equipment at the group distributing frame as is current practice. Or, they may be arranged such that five channel groups (banks) are combined within the UFT to directly form a supergroup (60 VF channels) and interface at the supergroup distributing frame.

Each frame may be equipped with plug-in units to provide one-way or two-way carrier failure alarms if required. This feature provides a prompt notification to the No. 4 ESS of a carrier failure and subsequent restoration. For two-way operation, the alarm is used to notify the distant end of an incoming failure. It permits both ends of the trunk to be properly conditioned when a carrier system fails and again when it is restored.

Each frame may be equipped for local access in the equipment aisle, only or equipped for both local and remote access from a central 51A test position through the Switched Maintenance Access System (SMAS 3B).⁵

Recommended arrangements call for frames to be installed in full sets comprising 40 channel banks and 480 VF channels. Such a set fully utilizes the carrier frequency supply common to 40 banks, allows standard wiring and identification of banks used to form supergroups (some of which span more than one frame), and permits standard and orderly application of connectorized cabling.

5.1.2 Metallic Terminal Frame

Short-distance toll connecting trunks, operator trunks, and a variety of other trunks utilize only cable pairs (sometimes enhanced by voice-frequency repeaters and signaling range-extension devices) as the transmission facility. Digital facilities are rapidly replacing these purely metallic (noncarrier) trunks throughout the Bell System. This process is expected to accelerate with the introduction of the DT because of the economy of the direct digital interface. Although the number of metallic trunks will be small, it is necessary to provide for their interface with No. 4 ESS.

Metallic trunks use dc signaling in a variety of forms. Signaling con-

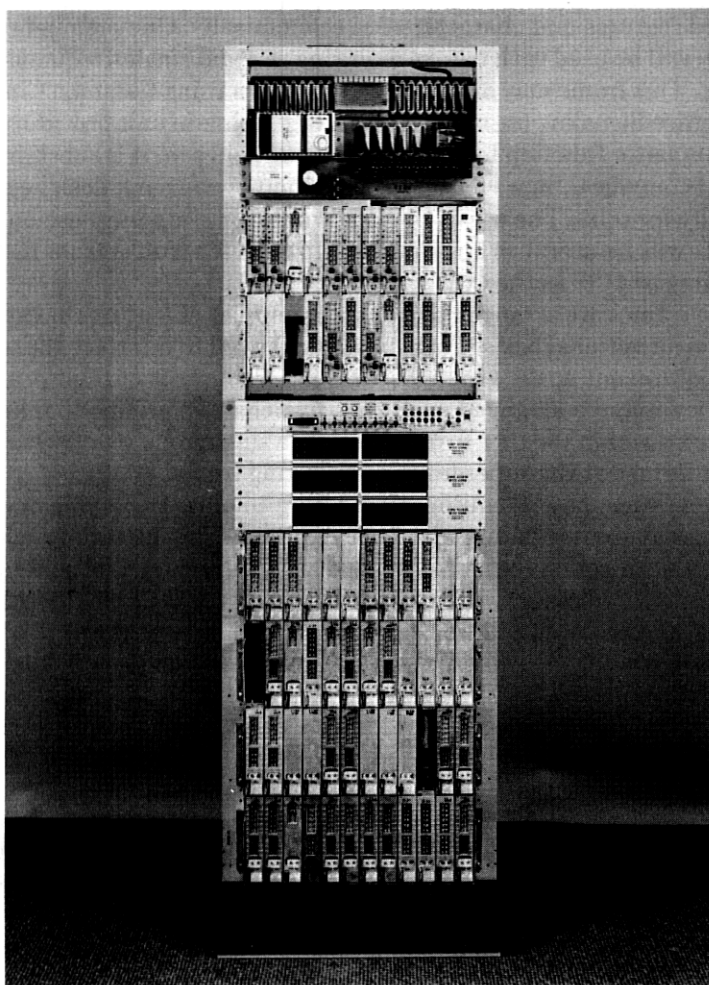

Fig. 19—Metallic terminal frame.

version must normally be performed to meet the standard SP signaling interface (four-wire E and M). Transmission gain or attenuation is normally required to meet the standard transmission level at the VIF interface. Since many of these trunks utilize two-wire facilities, two- to four-wire conversion is frequently required.

The Metallic Terminal Frame (MTF) has been designed to provide a single package capable of terminating the variety of metallic trunks likely to interface with No. 4 ESS. The frame is shown in Fig. 19. A family of plug-in metallic terminal units has been designed to accommodate the signaling, transmission, and service type variables (loop pulsing,

battery and ground pulsing, two-wire, four-wire, incoming, outgoing, operator, message, etc.).

Connectorization has been applied between the MTF and VIF and SP in exactly the same form as for the UFT. Additionally, connectors and single-ended connector cabling tie the MTF to the outside cable plant via the main distributing frame. Provisions similar to those provided in the UFT for local equipment aisle or optional remote testboard maintenance access have been incorporated in the frame design.

5.1.3 Digroup Terminal

Interconnection of the DT to the No. 4 ESS differs markedly from the analog UFT and MTF since there are no requirements to interconnect on the level of individual VF channels. Single-ended connectorized cables connect the DT to the digital cross-connect frame (DSX-1) or directly to office repeaters. Only four such cables are required for the full 40-digroup (24 VF channels each) capacity of the DT.

5.1.4 Multifrequency signaling receivers and transmitters

Address signaling in No. 4 ESS may be in the form of dial pulsing, multifrequency (MF) pulsing, or digital data on a common link in CCIS. Multifrequency pulsing is the dominant mode in today's toll network but will diminish with the deployment of the CCIS network.

MF receivers and transmitters are not dedicated to specific trunks but form a common pool such that any idle transmitter or receiver may be selected by the No. 4 ESS to transmit or receive MF pulses on any MF signaling trunk. Each receiver interfaces with a VIU to permit reception of MF signals from an incoming trunk through a switched connection. A multilead interface with the SP permits it to identify the received MF pulses for subsequent interpretation by the 1A Processor. Similarly, each transmitter interfaces with a VIU for transmission of MF signals via a switched connection to an outgoing trunk. The SP provides the address to be outputted to the MF transmitter.

The MF signaling frame (shown in Fig. 20) mounts up to 32 receivers and 32 transmitters and is connector-cabled to the VIU and SP. An optional terminal strip provides a convenient means to connect other service circuits into the No. 4 ESS. Terminal strips are also used to connect MF testing circuits, optionally mounted on the multifrequency signaling frame, and to provide loop arounds for periodic No. 4 ESS internal testing.

5.1.5 Maintenance equipment

All UFT and MTF frames may be optionally equipped for 51A test position access by the SMAS 3B.

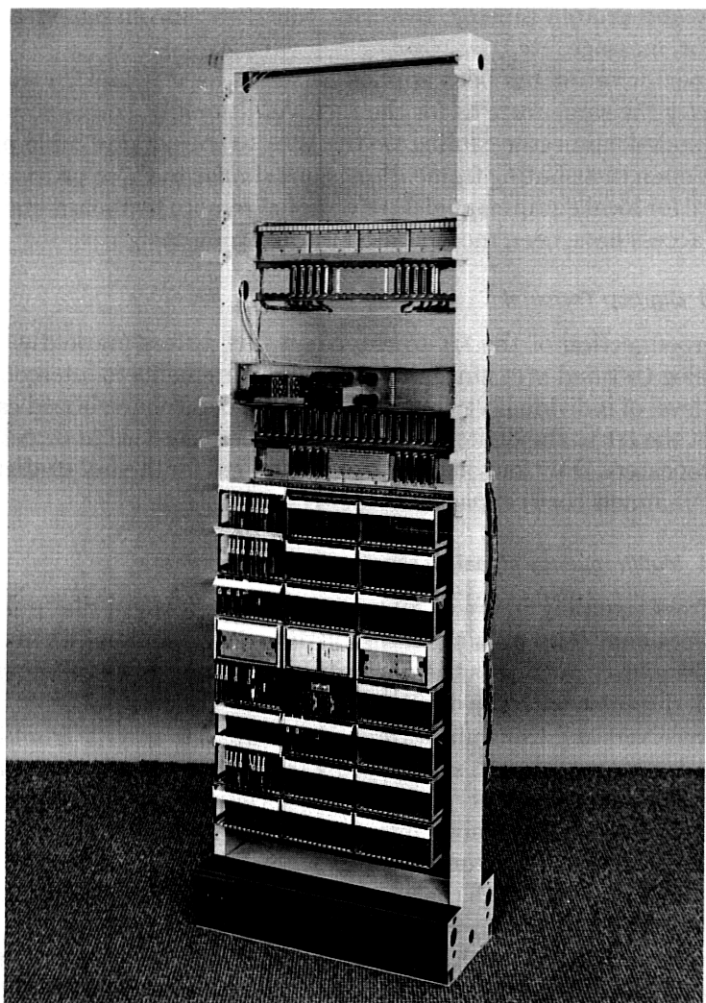
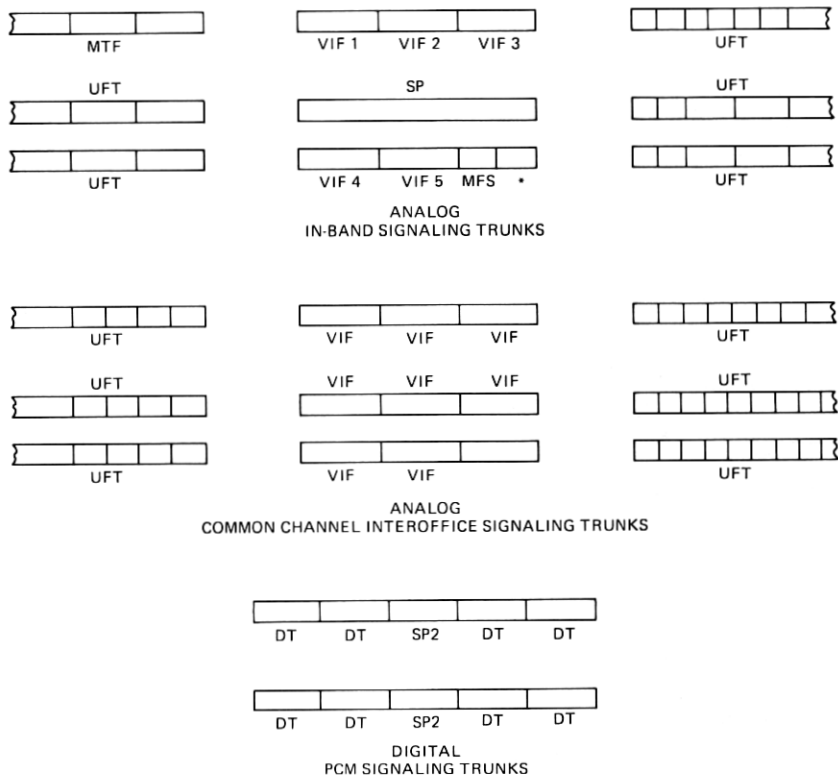

Fig. 20—MF signaling frame.

The optional SMAS allows one craftsperson at the 51A test position to gain access to both the switching interface (VIU) and transmission facility (carrier or cable) interface by a simple dial-up procedure or through CMS. Having both points readily available, the craftsperson can rapidly sectionalize trunk troubles within the building and achieve fast repair and restoral.

5.2 Floor plans

While full connectorization demands effective control of the floor plan to avoid cable-rack congestion and cable routing problems, a completely



* LOCATION FOR ECHO SUPPRESSOR TERMINAL OR MISCELLANEOUS FRAMES AS REQUIRED

Fig. 21—Basic core area layouts.

fixed floor plan would be too inflexible to meet network requirements. The modularity of the VIF, SP1, SP2, and DT made possible the creation of fixed core areas. These cores effectively confine and control cabling to near optimum but retain the flexibility to cope with wide variability in facility mix and growth patterns.

5.2.1 Analog basic core

The basic analog core illustrated in Fig. 21 combines five VIFs with an SP1 and, when required, an MF receiver and transmitter frame (MFS). SP1 provides signaling terminations for 4080 trunks and 2048 miscellaneous scan and distribute points. Each VIF mounts seven working VIUs, terminating 840 VF channels. Five VIFs mount a total of 35 active VIUs but one VIU is needed for the MFS and other service (nontrunk) circuits. The remaining 34 VIUs provide 4080 trunk appearances exactly matching the SP capacity.

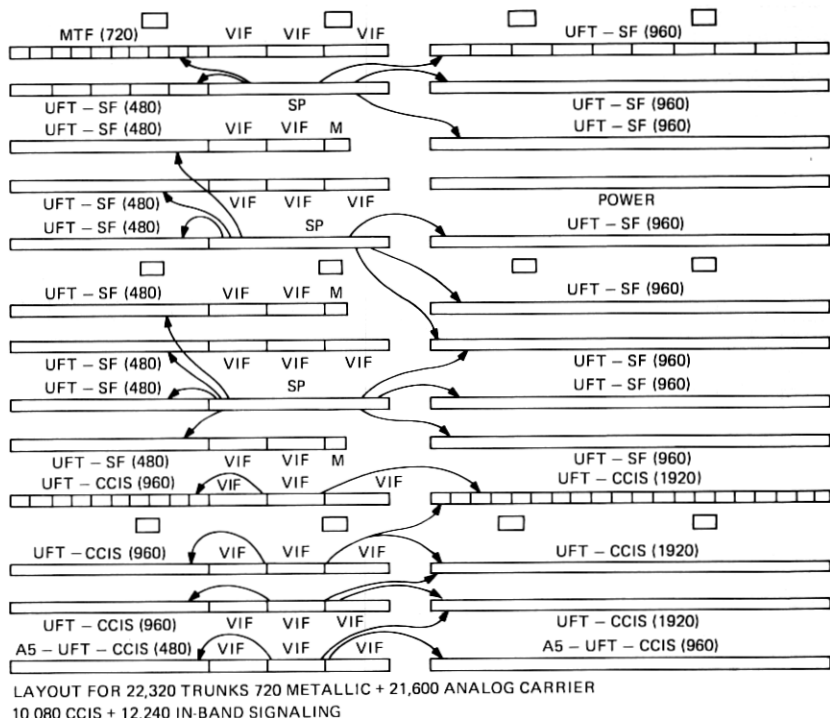

Fig. 22—Analog floor plan.

With UFT and/or MTF flanked on either side of the core, the bulk of the cables will either simply run longitudinally within the frame-mounted cable rack or make one transverse run cross-aisle to an adjacent lineup. Right- and left-hand feeds minimize cable crossover and pileup, which lead to congestion. Trial layouts and experience indicate that cable length should rarely exceed 80 feet.

5.2.2 CCIS basic core

Signaling information for CCIS trunks is carried on a common data channel so the per-trunk SP signaling appearances are not required. The core therefore reduces as shown in Fig. 21. The resulting higher density compared with the in-band signaling core is compatible with the higher density achieved in the CCIS UFT. Retaining the same dimensions for the CCIS core allows both types of cores to be mixed as required to suit growth patterns.

5.2.3 Digital core

The basic digital core shown in Fig. 21 consists of four DT frames and one SP2 frame and serves 3840 MF or dial-pulse signaling trunks.

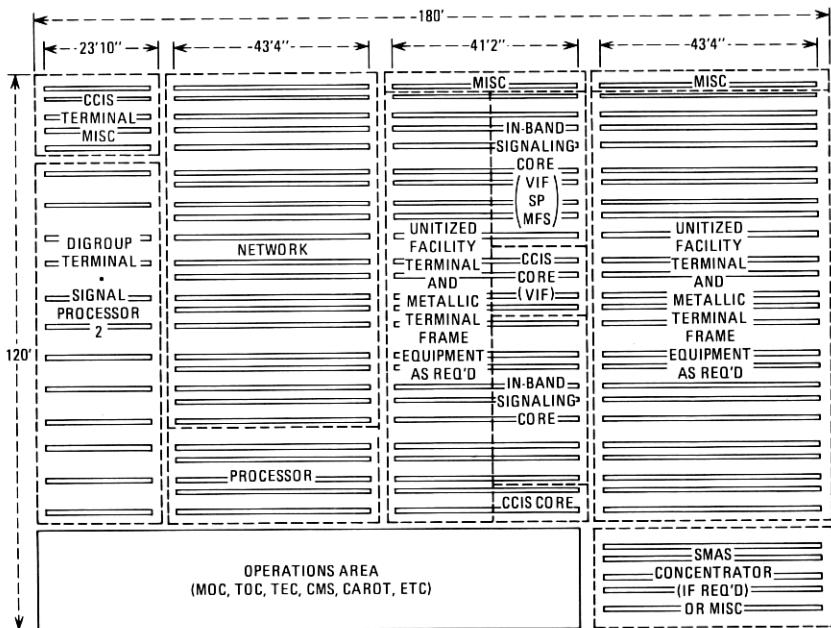

HYPOTHETICAL FLOOR PLAN LAYOUT APPROXIMATELY 82,000 TRUNKS
 40,000 ANALOG (40% CCIS) 42,000 DIGITAL (25% CCIS)

Fig. 23—Overall floor plan.

In addition, one SP2 may also serve up to 11,520 CCIS trunks utilizing 12 additional DTs.

If the number of miscellaneous scan and distribute points required for the office (for such functions as office alarms, analog echo suppressor control, network management, etc.) exceeds the number provided by the SP in the analog cores, then a supplementary matrix frame may be added to the SP2. An office with a high percent of digital MF trunks may require supplementary matrix frames to terminate an adequate number of MFS frames.

5.3 Example floor-plan layouts

A hypothetical layout of analog core areas in No. 4 ESS is presented in Fig. 22. This compact arrangement serves 22,320 trunks (45 percent CCIS) in an area of approximately 6200 square feet (100 × 62). The directed lines indicate the cabling patterns for the SP-to-UFT connections. Similar patterns apply for the VIF-to-UFT connections.

In Fig. 23, the previous example is expanded to illustrate a complex as it might appear on one floor in a central office building. The trunk capacity is approximately 82,000 with 40,000 analog trunks (40 percent CCIS) and 42,000 digital trunks (25 percent CCIS). In the analog core area,

the layout of the previous example was taken to be an initial installation. This example shows how growth units can be added in an orderly and efficient manner. It may be noted that the CCIS and inband signaling cores become mixed in this growth process.

The DT area indicates that the frame layouts are spread to maintain a suitable heat load for conventional air conditioning. The lineups are located to align with network frame lineups to facilitate cabling passing between the two areas.

The trunk capacity of the area shown in this example, approximately 21,600 square feet (180 × 120), is influenced by the percentage of CCIS trunks. If there were no CCIS trunks, for example, the capacity would reduce from 82,000 to approximately 72,000.

If traditional means for providing toll terminal equipment were used, this overall floor-plan arrangement for an 82,000-trunk office would change substantially. The floor space requirement for toll terminal equipment would approximately double if 7-foot frames were used and increase more than 40 percent for 11-foot, 6-inch frames. Over one million distributing frame terminations would be required with the installation of over one-half million cross-connect wires. One physical distributing frame would probably not be usable because of its excessive length (over 300 feet for 7 foot frames and 185 feet for 11-foot, 6-inch frames). Multiple frames would require interconnection tie cables. The number of cables required would approximately double and the average length of cable would increase by a factor of about six. Administration and maintenance of such large distributing frames and of the equipment which would be spread over a much larger area could be expected to substantially increase work force requirements.

VI. SUMMARY

In this paper we have addressed the interface between the transmission facilities and the No. 4 ESS. We have discussed the terminals, equipment arrangements, floor plans, etc., that collectively make up the interface between the facility terminations at the distributing or cross-connect frames and the switch itself. Seen from the switch, the transmission interface consists of serial PCM links using the DS-120 format, each carrying 120 two-way voice-frequency channels. We have described the two new terminals—DT and VIF—that interface digital and analog transmission facilities, respectively, to the DS-120 links.

The interface for digital facilities is particularly clean: the DT is the only frame required between the DSX-1 and the switch. There is no per-trunk circuitry; even signaling information is exchanged between the DT and SP2 on a 2-Mb/s multiplexed link.

We have seen that the interface for analog facilities has also been streamlined. Viewed from the facility, a standard interface is provided

by the four-wire VF transmission channel at the VIF and the four-wire E and M signaling port of SP1. Unitized facility terminals have been designed to provide in a single package all the required functions between the basic facility distributing frames and the VIF-SP1 interface. This analog arrangement has substantially reduced both interframe, per-trunk cabling and distributing frame terminations.

We have presented the terminal equipment arrangement for a typical system and seen that the combination of standardized interfaces, unitized terminals, modular floor plans and the nature of the switch itself results in a rather dramatic reduction in floor space, cabling, and distributing frames, when compared with traditional offices.

In closing, it is worth noting that the DT and VIF represent the first generation of what may be a line of terminals that combine classical transmission and switching functions and/or techniques. Both DT and VIF, in addition to their transmission roles in providing multiplexing, conversion, framing, etc., have access to the switching system processor. Both frames incorporate extensive maintenance hardware that functions with the processor access to achieve a high level of fault detection, diagnosibility, and reconfigurability. Further applications of processor access would seem possible. Lastly, we note the disappearance of the single-voice channel as the switching/transmission interface. In particular, while single-channel access is always provided via the switch and maintenance systems, the DT itself provides no physical single-channel appearance.

REFERENCES

1. J. Janik, et al., "No. 4 ESS: Peripheral Systems," B.S.T.J. (this issue).
2. R. E. Staehler, "1A Processor: Organization and Objectives," B.S.T.J., special issue on 1A Processor, 56, No. 2 (February 1977), pp. 119-134.
3. J. O. Becker, et al., "1A Processor: Technology and Physical Design," B.S.T.J., special issue on 1A Processor, 56, No. 2 (February 1977), pp. 207-236.
4. K. E. Fultz and D. B. Penick, "The T1 Carrier System," B.S.T.J., 44, No. 7 (September 1965), pp. 1405-1452.
5. M. T. Smith, Jr., et al., "No. 4 ESS: Data/Trunk Administration and Maintenance," B.S.T.J., this issue, pp. 1203-1238.
6. H. H. Henning and J. W. Pan, "D2 Channel Bank," B.S.T.J., 51, No. 8 (October 1972), pp. 1641-1657.

