

Remreed Switching Networks for No. 1 and No. 1A ESS:

Transmission Design and Environmental Protection of Remreed Networks

By C. H. KLOSTERMAN and J. E. UNRUE, Jr.

(Manuscript received November 11, 1975)

The transmission characteristics of remreed networks have been designed to support a wide variety of switched services. These include local- and toll-switched voice-message and voiceband data services. Also, looking toward the future, the remreed network has the capability of supporting wideband services such as analog Picturephone® service and T1 bit streams. In a class of space-division networks, it approaches being an ideal noninteractive extension of the switching-office cabling.

This article discusses the transmission and environmental protection aspects of remreed networks. The objectives and requirements used to control the transmission and protection design for remreed networks are given and the resulting performance characteristics are described.

I. INTRODUCTION

The switching network of a telephone central office serves the function of interconnecting the many lines and trunks of the office with each other and with service circuits such as tone sources, signal transmitters, signal receivers, etc. For the duration of the connection, the switching network constitutes a portion of a transmission channel over which communication takes place.

The remreed network for No. 1 and No. 1A ESS is a space-division metallic network. The transmission channels are formed by interconnecting metallic conductors with metallic contacts, and electrical isolation of different channels is achieved by physical separation in space. The remreed network is also classified as a two-wire network since, for each connection, two independent metallic-conductor paths are established: the so-called tip (T) and ring (R) conductors.

In the ideal case, the T and R conductor paths of a remreed network would form a noninteractive extension of the office cabling appearing at the network terminals. The electrical isolation between channels would be complete (infinite coupling loss), and the transmission channel would contain no internal noise sources. Furthermore, this would ideally be true at all frequencies. Of course, this cannot be achieved in practice but can be approached sufficiently by careful design.

The T and R conductors of the remreed network are extended into the outside plant of a telephone exchange area by cables. As a result, the remreed network is exposed to an electrically hostile environment. The system design must assure that the network will survive hazards such as lightning strikes, power-line crosses, and other electrical fault conditions. This requires a certain degree of ruggedness of the remreed network and the use of other external means of providing protection.

In this paper, we discuss the transmission and environmental considerations in the design of remreed networks and we focus primarily on the T and R conductors. General design objectives are discussed in Section II. Design factors affecting transmission are covered in Section III, followed by the measured transmission characteristics in Section IV. Section V covers the environmental protection aspects of the design.

II. GENERAL DESIGN OBJECTIVES

2.1 Transmission

To enjoy the economies of high-volume production, it is desirable for the apparatus and equipment used in remreed networks to support a wide variety of present and future services. Therefore, the transmission design has been guided not only by the requirements of the present applications, but with an eye toward future applications as well.

Some of the future applications would increase the bandwidth requirements of the network. Others would involve changes in the transmission mode in which the T and R conductors are used to obtain an "equivalent four-wire" switching capability.

2.1.1 Transmission modes

As previously noted, each connection establishes two independent conductor paths: the T and R conductors. In most applications, these conductors are used to form a single communication channel, as shown in Fig. 1. In this case, the conductors are usually balanced with respect to ground and the interconnecting equipment has source and

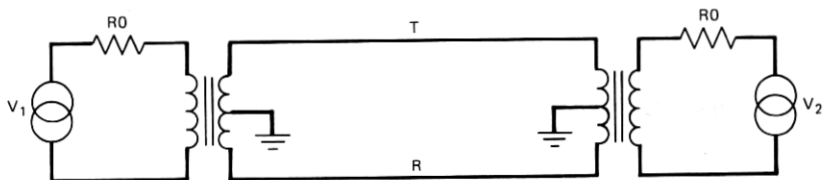

Fig. 1—Properly terminated balanced mode.

load impedances that approximate the characteristic impedance of the channel. We refer to this as the properly terminated balanced mode.

In some applications, the T and R conductors are used in separate circuits, each having common-ground return, to form two independent communication channels, as shown in Fig. 2. Such unbalanced circuits tend to be susceptible to crosstalk and other sources of interference unless certain precautions are taken. When such circuits are used in conjunction with remreed networks, the transmission mode is changed to the so-called HILO mode¹ to control crosstalk and other types of noise. In the HILO mode, the connecting equipment presents a very high source impedance and very low load impedance. This impedance relationship gives rise to the name HILO and reduces the interference susceptibility of the unbalanced circuits.

The properly terminated balanced mode is usually used in bilateral circuits where information propagates equally well in both directions. These are the so-called two-wire switching applications. In the HILO mode, each circuit is inherently unilateral, i.e., signals propagate in only one direction. The two HILO circuits of each connection are used to obtain an equivalent four-wire switching capability where one

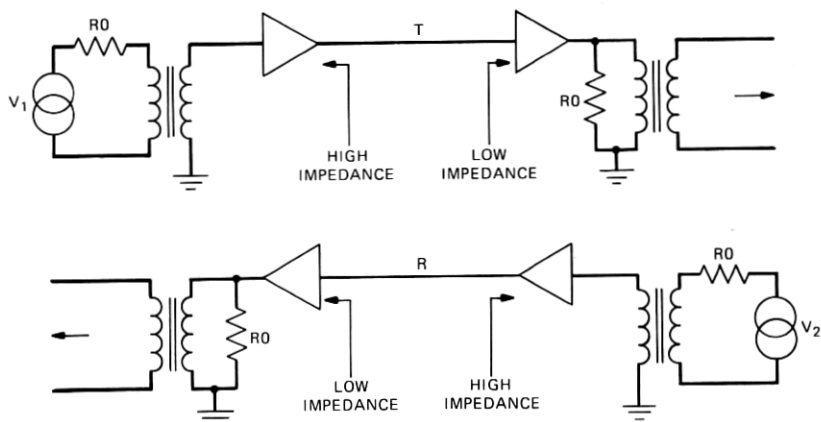

Fig. 2—HILO unbalanced mode.

circuit is used for "east-to-west" communications and the other for "west-to-east."

2.1.2 Applications

The initial and predominant use of remreed networks is for two-wire voiceband switching in local, tandem, and toll offices. The properly terminated balanced mode is used in these applications. The HILO mode will be used for equivalent four-wire voiceband switching in No. 1 ESS and No. 1A ESS in toll and other special applications.

Looking toward the future, remreed networks are expected to be used for wideband switching applications. These include such services as Picturephone® service and various analog and digital data applications. In most of these cases, the nature of the service requires an equivalent four-wire connection, which may be obtained using a single connection and the HILO transmission mode, or by establishing two connections and using the properly terminated balanced mode.

2.1.3 Transmission objectives

In the ideal case, from a transmission point of view, the T and R conductors of remreed networks would be equivalent to a section of multipair cable. As in cable, the transmission parameters of primary importance are the insertion characteristics, crosstalk characteristics, and susceptibility to external noise sources. Design objectives were established for each of these parameters, taking into account the many switched services for which the remreed networks may ultimately be used.

In the case of wideband services, several were studied for the purpose of establishing meaningful transmission objectives. These include analog Picturephone service, 64-kb/s digital data, and 1.544-Mb/s digital data (equivalent to a T1 line signal). It is presumed that these are representative of a wide class of analog and digital signals that may be switched in the future.

The design objectives applied to the remreed network were derived from transmission objectives established for local and toll switching offices as a whole. The remreed network is a subsystem in the office. Therefore, it was necessary to allocate the office objectives among the various subsystems: trunk and junctor circuits, remreed networks, and interframe cables. Also, it proved desirable to further allocate these objectives to the network apparatus level since it is at this level that one can exercise design control. In this manner, objectives were established for concentrator grids, trunk grids, and junctor grids.^{2,3} These subsystems are similar from a transmission viewpoint since each includes two switch stages. Therefore, they each received the

Table I — Grid transmission objectives

1. Single-disturber equal-level crosstalk objectives:

Frequency (kHz)	Minimum Coupling Loss (dB)		
	Balanced (a)	HILO Interchannel (b)	HILO Intrachannel (c)
3.4	90	90	90
32	45	50	35
400	65	—	—
750	45	50	35

a. Between any two T-R conductor pairs.
 b. Between any two T or R conductors except mate conductor.
 c. Between T and mate R conductors.

2. Impulse noise: less than 11 mV into 110-ohm terminations.
3. Minimum 3-dB bandwidth (balanced mode): 5 MHz.
4. Maximum T or R conductor resistance: 1.5 ohms @ 20°C.
5. Maximum unbalance resistance between T and mate R conductors: 200 milliohms @ 20°C.

same allocation, which we will refer to as grid objectives. The grid objectives that were established are summarized in Table I.

In the case of the HILO mode, we distinguish two different types of crosstalk couplings: interchannel and intrachannel. As previously noted, the HILO mode is used for equivalent four-wire applications so that each connection establishes two communication channels. Crosstalk between the two channels of the same connection is called intrachannel coupling. Crosstalk between channels of different connections is called interchannel coupling. Intrachannel coupling is more difficult to control since these two channels are in close proximity to each other throughout the entire connection. This fact must be recognized when allocating objectives.

In most of the wideband cases, it is not the single disturber crosstalk that is important, but the crosstalk in a particular channel that is the sum of all disturbers. Design control can be reasonably exercised only for the worst disturbers. The objectives allocated to a grid, which apply to the single worst disturbers, were chosen so that the more pertinent objectives for the sum of all disturbers would be guaranteed.

A crosstalk objective was not established for the HILO mode at 400 kHz. This frequency is pertinent to vestigial sideband modulated analog Picturephone signals. Remreed grids are under consideration for line-concentration functions in Picturephone switching applications.

However, the HILO method of equivalent four-wire switching cannot be used in this case due to the large difference in signal levels between the east-to-west and west-to-east channels. Instead, the balanced mode would be used, with the transmission directions segregated into different grids.

2.2 Environmental protection

2.2.1 Environmental hazards

In normal system operation, the T and R conductors of remreed networks will be subjected to a number of electrical stresses. Table II indicates some common operational voltages that appear in local exchange area network applications. Also shown are estimates of the cumulative duration over a 40-year design life that particular conductors may reasonably be expected to have the given voltage impressed.

We can observe from Table II that the simultaneous presence of coin voltage and range-extended ringing on adjacent conductors will result in a peak potential difference of 362 V between the conductors.

In many applications, the T and R conductors of the network are extended directly by other metallic conductors into the outside plant of an exchange area. As a consequence, the remreed network can be subjected to a number of natural and man-made electrical fault conditions caused by lightning strikes, power-line crosses or ground faults, and incorrect maintenance and repair actions. When these fault conditions occur, the voltages can exceed the values given in Table II by a considerable amount.

Lightning strikes can, in rare cases, result in voltage transients that approach 1000 V peak with respect to ground.⁴ Improper use of cable-fault-locating equipment can result in 600 V dc being impressed on the network conductors. Ground faults in power-distribution lines can induce voltages on the T and R conductors which range from negligible values to several hundred volts as a function of such variables as the

Table II — Normal operational voltages

Source	Voltage	Estimated Cumulative Duration Per 40 Years, Per T-R Pair
Line battery	± 52 Vdc	50,000 hours
Coin voltages	± 135 Vdc	6,000 hours
Range-extended ringing	149 V peak 20 Hz superimposed on -78 Vdc	2,000 hours

power-distribution voltage, location of the ground fault, and proximity of the telephone plant.

2.2.2 Environmental protection objectives

In the case of the normal system operational stresses, the design of the remreed networks must be such as to withstand these stresses over its design lifetime (40 years). This, of course, is true also for all other equipment in the connecting complex of the system, such as trunk and junctor circuits. However, it is not economically practical to design all central office equipment to withstand every possible fault condition without damage. Nevertheless, catastrophic service-affecting failures cannot be tolerated. To minimize the service effect under fault conditions, a preferred order of failure has been established as follows:

- (i) Trunk- or junctor-circuit failures.
- (ii) Network switch-contact failures.
- (iii) Network link-wiring failures.

When this order of equipment failure is maintained, the probability of multiple equipment failure is minimized, restoral effort is minimized, and switching network traffic-carrying capacity is maximized.

Most No. 1 ESS trunk circuits are plug-in units and are easily replaced. Single network crosspoint failures can be tolerated because excessive traffic blocking will not occur until multiple crosspoint failures accumulate, at which point an individual grid can be replaced. A single network link-wiring failure will eliminate from service the accessibility of eight stage-0 crosspoints and eight stage-1 crosspoints in a grid and will reduce the traffic-handling capacity of a remreed grid sooner than, for example, individual crosspoint failures.

To achieve the above preferred failure order, the failure limits of trunk and junctor circuits were studied along with the characteristics of protection devices such as carbon blocks. Also, the action which the system takes in response to each failure was determined. (These studies are discussed in Section V). The design objectives for electrical faults for the remreed network apparatus were established. These objectives were to sustain without damage the following:

- (i) 900-V peak; 10- μ s risetime \times 1000 μ s fall time transient.
- (ii) 800-V peak 60-Hz ac for 1 second.
- (iii) 600-V dc for 1 second.
- (iv) 3 A rms for 2 minutes.
- (v) 2 A rms for 10 minutes.
- (vi) 1.5 A rms continuously.
- (vii) 5 A rms for 1 second (link wiring only).

III. TRANSMISSION DESIGN

3.1 Constituent parts of remreed networks²

In this section, we describe the constituent parts of remreed networks from a transmission point of view. More complete descriptions can be found in Refs. 2, 3, and 5.

The equipment organization for transmission through remreed networks is shown in Fig. 3. A connection can involve different equipment units, depending on the switching function of a call—intraoffice, interoffice, or tandem.

The connections through the network consist of several path segments in either a line link network (LLN), trunk link network (TLN), or both. The link networks are further broken down into frames. The LLN consists of line-switching frames and junctor-switching frames, while the TLN consists of junctor-switching frames and trunk-switching frames.

The line-switching frames give rise to two stages of switching in the interconnecting process, connecting line terminals at their inputs to B links at their outputs. The line-switching frames perform a basic network function of concentration. Two types of line-switching frames have been provided: one concentrates by a ratio of 4 to 1 between input lines and B links and the second concentrates by a ratio of 2 to 1. Associated with the line-switching frames are junctor-switching frames. The junctor-switching frame also performs two stages of switching: it interconnects B links and juncctors. Juncctors are the central link of every network connection. The final type of network frame is the trunk-switching frame, which also performs two stages of switching, interconnecting B links and trunk terminals. The basic junctor- and trunk-switching frames have 1-to-1 concentration ratios.

Each type of switching frame consists of apparatus called grids, which contain the stage-0 and stage-1 switches and their associated interconnecting A or C link wiring as indicated in Fig. 3. Four types of grids are used. The line-switching frames use the 13A-type grid to provide 4-to-1 concentration and the 12A-type grid for 2-to-1 concentration. The junctor-switching frame uses a 10A-type grid and the trunk-switching frame uses an 11A-type grid.

The above grids contain different types of switches. The switches in turn contain a basic component of the remreed networks, the 238A, miniature, sealed-reed contact.⁶ These sealed contacts are physically associated in pairs, one used for the T-conductor path and the other for the R-conductor path. These contact pairs and their associated control elements are called crosspoints and are packaged and interconnected in the remreed switches to form spatial arrays. There are several switch types, each providing either a unique T-R array con-

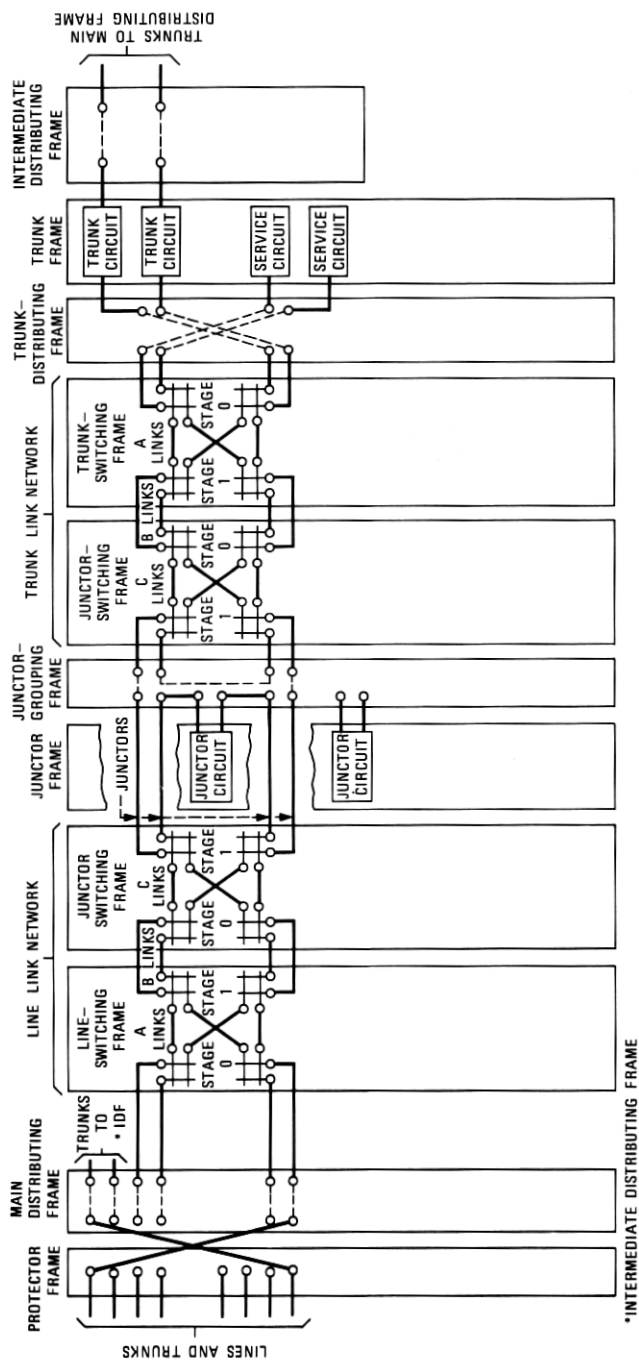

Fig. 3—Equipment schematic.

Table III — Switch types

Switch Code	Array Configuration	Used-In-Grid Code
296-1A	2— 8 × 8	10A, 11A
296-1B	2— 8 × 8	11A
296-1C	2— 8 × 8	10A
296-2A	4— 4 × 8	12A, 13A
296-3C*	4— 4 × 4	12A
296-4C*	1—16 × 4/8	13A
296-5D†	4— 1 × 8	10A

* Switch also contains 16 cutoff crosspoints and associated line ferroids.

† Contains 32 crosspoints used to give the junctors access to a common test vertical.

figuration or crosspoint-control function. Table III lists the different types of switches, the number of and type of array patterns provided, and identifies the type of grid in which it is used.

The interconnection of the switching frames is by switchboard cables whose transmission characteristics are well understood. Therefore, the remaining discussion will focus attention on grids and switches.

3.2 Physical design

Miniaturization places a greater importance on physical design to control and minimize factors which affect transmission, such as crosstalk and other types of noise. A remreed switch package can contain up to 128 crosspoints and associated electronic control devices. These components are interconnected with flexible printed wiring to form the arrays in the switch package. On each switch, two flexible printed-wiring planes are used: one that forms the horizontal interconnection plane and a second that forms the vertical interconnection plane for each array. Each flexible printed-wiring plane is a double-sided circuit containing the T-R conductors and associated pulse and control conductors. The flexible printed-wiring planes are cemented to epoxy-coated steel boards, which are part of the crosspoint support structure. The steel core of these boards is grounded. To provide maximum crosstalk isolation, the physical relationship between the T-R conductors and ground planes was controlled to minimize the capacitive unbalance to ground of the T-R conductor pairs. The T and R conductors of a pair were oriented on opposite sides of the circuit in a vertical colinear geometry. The advantage of this orientation is shown in Fig. 4a and the method used to equalize capacitance to ground is shown in Fig. 4b.

When mounted in a grid, the switch packages are interconnected to permit each input T-R terminal pair of the stage-0 switches to have access to each output T-R terminal pair of the stage-1 switches. These interconnections are called links, and are identified as A links in the

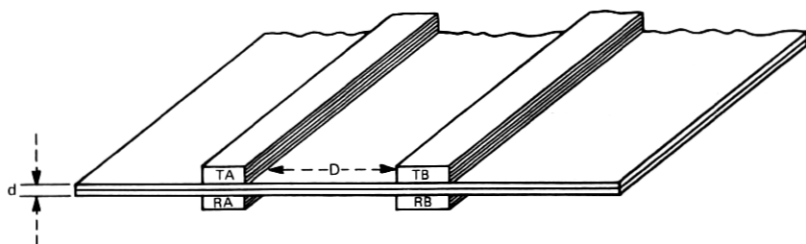

$$\text{UNBALANCE CAPACITANCE: } C_U = [C_{TATB} - C_{TARB}] + [C_{RARB} - C_{RATB}]$$

$$\therefore C_U \text{ SMALL WHEN } \frac{d}{D} \leq 0.1$$

$$\text{SINCE } C_{TATB} \approx C_{TARB}$$

$$C_{RARB} \approx C_{RATB}$$

(a) T AND R CONDUCTOR GEOMETRY

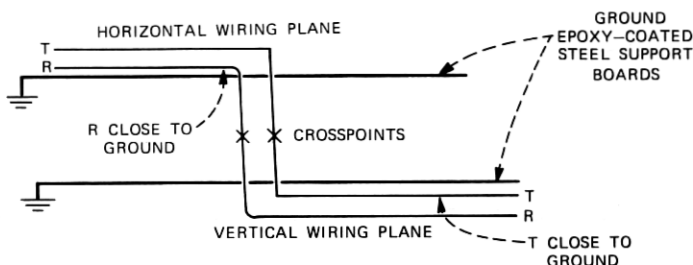

(b) METHOD FOR EQUALIZING CAPACITANCE TO GROUND

Fig. 4—(a) Tip- and ring-conductor geometry. (b) Method for equalizing capacitance to ground.

11A, 12A, and 13A grids and C links in the 10A grids. The A- and C-link wiring patterns are shown in Figs. 5 through 7 for the 10A, 12A, and 13A grids. The 11A-grid, A-link wiring pattern is similar to that of the 10A grid shown in Fig. 7 except that the test-vertical cross-points are not present.

The A- and C-link interconnections were originally made with 30-gauge insulated wires applied by automatic wiring machines. Special care was taken here to define the routing of the T-R pairs between the stage-0 and stage-1 switches. The intent of the routing specification was to keep close physical proximity between the two wires which form a T-R pair. Based on a consideration of the economics associated with the automatic wiring machines, it was determined that the link wiring should be applied such that the vertical T-R route lengths would be minimized at the expense of lengthening the horizontal T-R routes. This was done to maximize T-R pair adjacency over the longer horizontal route and thereby reduce capacitive unbalance between different T-R conductor pairs. Shown in Fig. 8 is the terminal field of the

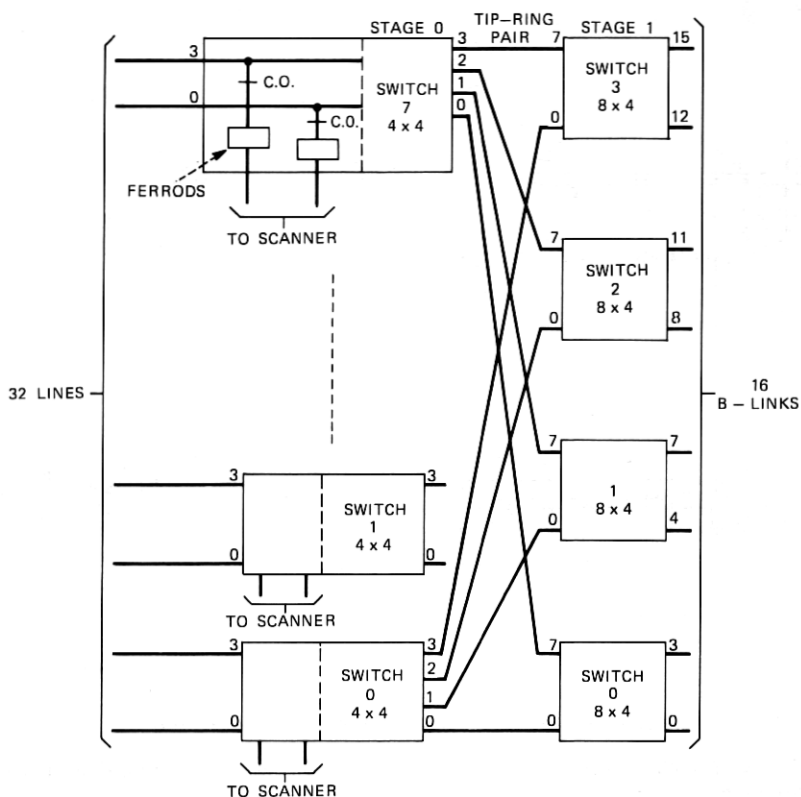

Fig. 5—Line-switching frame—tip-ring block diagram of a 2-to-1 concentrator.

stage-0 and stage-1 switches in a grid. The T-R pairs can be routed in the same terminal channels in the horizontal plane but cannot be routed economically in the vertical plane.

As a substitute method, grid-A and C-link backplane interconnections by means of flexible printed circuits have also been developed. Unlike the switch flexible circuits, on which the T-R conductor pairs are oriented in a vertical colinear geometry, in the backplane flexible circuitry, the T-R conductor geometry is similar to that designed for the wired grids. This follows the practice of requiring the T-R conductor pairs to lie in the same terminal channels when routing in the longer horizontal plane and allowing one terminal channel separation in the shorter vertical plane. It should be noted that for both the wired and the flexible backplanes, the longest T-R pair horizontal route is 11 inches while the longest vertical T-R pair route is only 3 inches.

Grids mounted in a switching frame must be interconnected with other grids in the associated switching frame to form a complete link

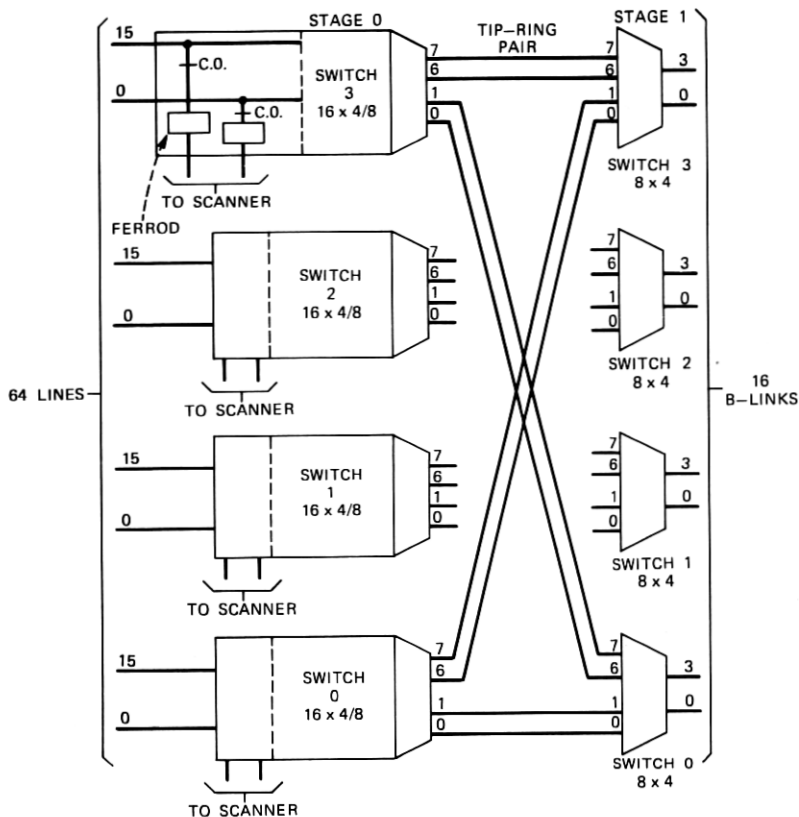

Fig. 6—Line-switching frame—tip-ring block diagram of a 4-to-1 concentrator.

network. The purpose of this interconnection is to enable any input T-R line or trunk terminal to be connected to any junctor T-R terminal. This interconnecting link is the B link and is a formed connectorized cable utilizing standard pvc, insulated, 26-gauge twisted pairs. The length of the B-link cable for a maximum-size 2048 TLN is 10 feet \pm 7.5 feet. The number 2048 signifies the number of trunk and junctor T-R terminal pairs available.

The final interconnecting links are the juncctors. These links connect the LLN's and TLN's together. They are formed from standard 800-type switch-board cables connected to a junctor-grouping frame.

3.3 Network topology

Further control of crosstalk and other types of noise is obtained from the network topology of the remreed network. Maximum crosstalk-coupling exposure, the total length two independent T-R paths are

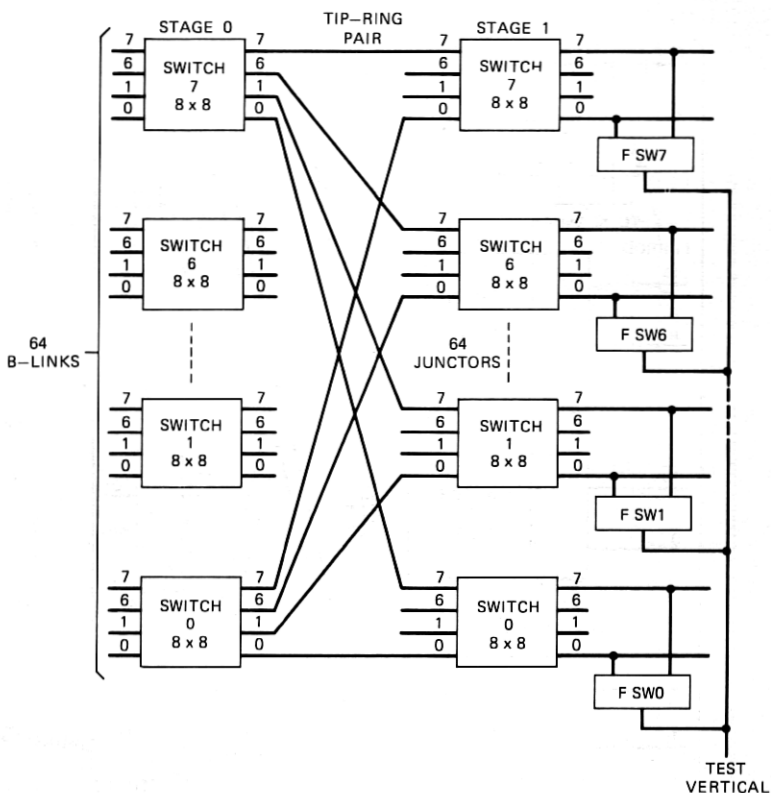

Fig. 7—Junctor-switching frame—tip-ring block diagram of a grid with test-vertical access.

in close proximity, is limited due to the topology of the network. For example, if two paths enter the same input switch of a grid, they cannot leave the grid through the same output switch. This example is valid for all switches except those used in the 4-to-1 line concentrator

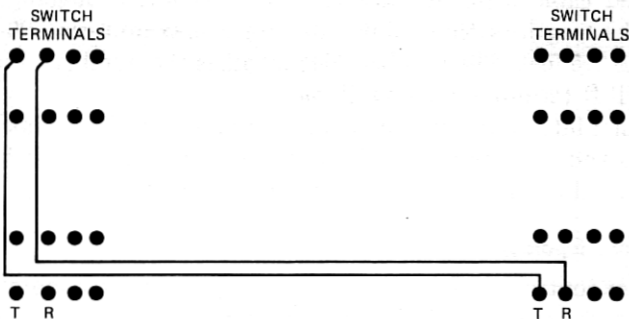

Fig. 8—Backplane wiring.

where a maximum of two paths can enter and leave the same switch. This can be seen by examining Figs. 5, 6, and 7. The B link T-R distribution pattern also reduces the possibility that the paths will ever be adjacent again. The importance of the network topology on crosstalk and other noise interference is that it breaks adjacency between two particular channels within the network and even minimizes adjacency in the office cabling external to the network.

IV. TRANSMISSION PERFORMANCE OF REMREED NETWORKS

The control of crosstalk and impulse noise were of primary concern in the design of remreed networks since miniaturization reduces conductor separations. The crosstalk requirements stated in Section II have been met for all planned and future switching applications, as indicated in Table IV. The measured crosstalk values stated are worst-case measurements. The average balanced mode and HILO interchannel crosstalk loss for a grid is 20 dB better. The average HILO intrachannel crosstalk is 3 dB better. The measurements shown apply to the 10A grid. This is the worst-case grid, due to the extra wiring associated with the test vertical. The other grids are generally 1 to 2 dB better.

In the HILO mode, intrachannel crosstalk becomes limiting as frequency increases. This crosstalk is dominated by the capacitive and magnetic coupling between the T and mate R conductors on the flexible printed circuits of the switch packages. As seen in Fig. 4A, this tight coupling is a direct result of the vertical colinear geometry

Table IV — Transmission performance

Grid Crosstalk Performance:

Frequency (kHz)	Minimum Coupling Loss (dB)		
	Balanced	HILO Interchannel	HILO Intrachannel
3.4	93	117	93
32	88	95	72
400	67	60	45
750	61	50	35

Impulse Noise: 0.7 mV into 110-ohm termination.

Grid Resistance Characteristic—T or R Conductor—Ohms @ 20°C:

	Longest Path	Shortest Path
Wired backplane	0.57	0.47
Flexible circuit backplane	0.82	0.76

that was chosen. A different geometry could improve the intrachannel coupling loss, but would impair the balanced mode crosstalk by increasing the unbalance capacitance. Due to the close proximity of the grounded support plane in the switch, it was more advantageous to use the geometry that minimized the unbalance capacitance.

The internal noise sources of remreed networks are thermal noise, impulse noise due to mechanical vibration, and impulse noise due to electrical coupling between the crosspoint-control circuitry and the T-R conductors. Thermal noise is negligible, as is impulse noise due to mechanical vibration. The worst-case impulse noise due to crosspoint operation is 0.7 mV when the T-R conductors are terminated in 110 ohms. This is well under the 11-mV objective. A number of design factors led to this good performance. The crosspoint structure of the switch packages includes a steel plate between the control windings and the T-R conductors that acts as a magnetic shield. Also, care was taken in the routing of switch flexible circuits and grid backplanes to achieve maximum separation between T-R conductors and conductors used for crosspoint pulsing and control.

The maximum resistance objective was met with margin, partly because the requirement imposed for current-carrying capacity controlled the design in this regard. This will be discussed in the next section. New grids generally do not display resistance unbalance greater than 10 milliohms. Over the lifetime of the grid, some unbalance can develop due to aging of the 238A, miniature, sealed-reed contact. However, this should stay well within the 200-milliohm objective.

The insertion loss characteristic of the 10A grid is shown in Fig. 9a and the phase response in Fig. 9b. The 10A grid is the limiting case for these characteristics, since it includes the additional wiring associated with the test vertical. Two curves are shown for each characteristic: one applicable to wired backplanes and the other applicable to flexible-circuit backplanes. The flexible-circuit backplane is somewhat more limiting because of the higher capacitance between T and R conductors, although both types of backplane meet the bandwidth objectives.

The above insertion characteristics apply to a grid. On an overall basis, the small physical size of the remreed network results in relatively short electrical and physical lengths of the T-R conductors through the network. For example, in a 1024 trunk link network, composed of four junctor-switch frames and four trunk-switch frames interconnected by B link cables, the maximum T-R length is approximately 18 feet and the minimum is approximately 7 feet. This makes the network contribution to office loss and loss contrast nearly insignificant.

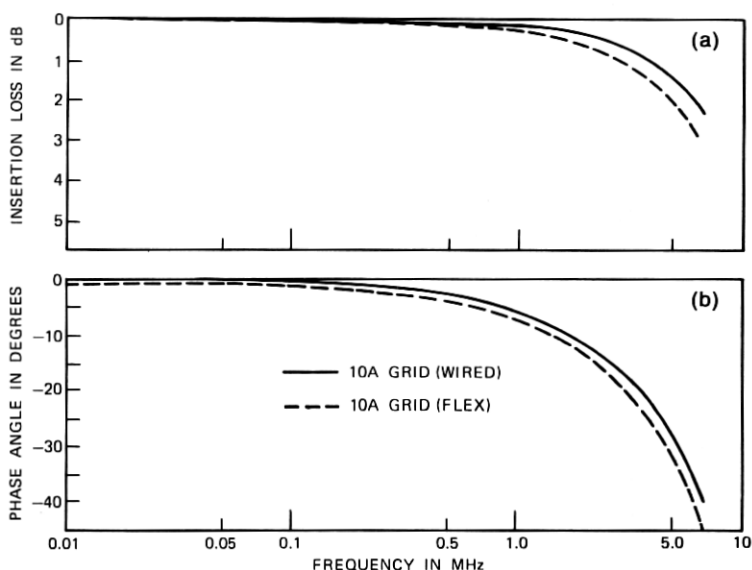

Fig. 9—(a) Insertion-loss characteristic of 10A grid. (b) Phase-response characteristic of 10A grid.

V. PROTECTION FOR REMREED NETWORKS

5.1 General

The remreed switching network provides the means for making interconnections between lines and trunks to be served by the No. 1 ESS system and also provides access to various service circuits required in handling telephone calls. For the duration of the call processing, the T and R conductors are exposed to outside plant and subjected to the operational and fault stresses that were identified in Section 2.2.

Protection for the remreed network T and R conductors is external to the network equipment frames but is associated with the network T and R conductors. The protection that is afforded depends upon the following items:

- (i) Carbon block characteristics.
- (ii) Central office cable resistance.
- (iii) Central office foreign-potential-detection circuits.
- (iv) Trunk- or junctor-circuit component-failure characteristics.
- (v) 238A-contact current-carrying characteristics.
- (vi) System-controlled actions associated with supervisory component-failure characteristics.

These items work in combination to prevent catastrophic network failures by limiting the damaging effects of electrical stress voltages and currents in both magnitude and time.

5.2 Voltage and current limiting for remreed networks

All remreed LLN network T and R conductors terminate on an office protector frame⁷ before interfacing with outside plant. At this point, 3-mil-gap carbon protectors are connected to the T and R conductors. These devices spark-over (break down) to ground when impressed by high voltages. The results of recent breakdown characterizations⁸ for the protector are given in Table V. These protector breakdown data indicate that the remreed network T and R conductors can be subject to voltages as high as 707 V rms, 60 Hz or 900 V peak for surges.

Carbon-block protectors are the only external protective devices required in Nos. 1 and 1A ESS and, from the above discussion, it is apparent that significant foreign-potential levels can enter the switching office. The carbon blocks connected to a T and R conductor pair are not selected for breakdown symmetry. Therefore, foreign potentials which exceed the lower bound of carbon-block breakdown voltages may appear on a T-R pair as a longitudinal (same voltage on T and R) or metallic (voltage differential due to one block breakdown) voltage.

As additional protection, office wiring and trunk service circuit components are designed to limit current through remreed network T and R conductors and contacts. Interframe T and R conductor wiring is 26 gauge, with a nominal resistance of 8.4 ohms per 100 cable feet. Switched connections between office distributing frames are limited to 1200 cable feet maximum to control the office insertion loss. This resistance, in addition to the impedances of trunk and service circuits, limits the current which can flow through the remreed T and R conductors.

5.3 Foreign-potential detection

Power-line-cross tests are made on lines during the initial stages of call processing.⁹ The tests are performed by certain service circuits.¹⁰

Table V — Three-mil-gap, carbon-protector breakdown characteristics

Condition	Mean Breakdown	Standard Deviation	Measured Maximum
60 Hz (rms) Surge (peak)	519 volts 707 volts	84 volts 89 volts	707 volts 900 volts

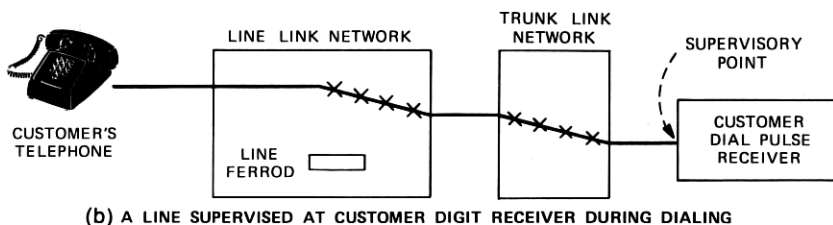
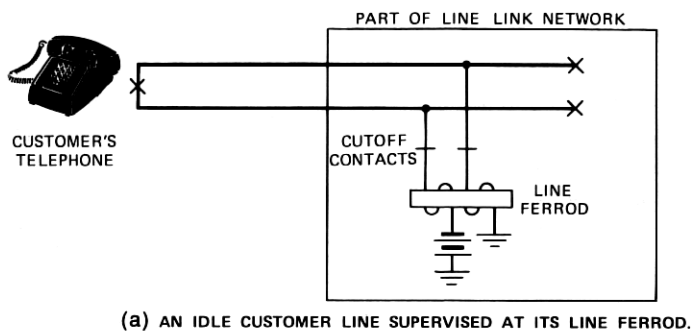

Fig. 10—(a) An idle customer line supervised at its line ferrod. (b) A line supervised at customer digit receiver during dialing.

For example, when a customer's line is on-hook, a 2A line ferrod^{5,11} is connected to the line through cutoff contacts, as shown on Fig. 10a. When a customer requests service (station set off-hook), the origination is detected by the line ferrod. The system then opens the cutoff contacts which removes the line ferrod from the line and, in turn, sets up a network path to the customer dial pulse receiver (CDPR), as shown in Fig. 10b. After the network path to the CDPR has been established, the initial action in the CDPR trunk circuit is to make a foreign-voltage test. If a foreign voltage of sufficient magnitude is detected, the call-processing procedure is abandoned. First the CDPR is released and then the first-stage network contacts are opened. The cutoff contacts associated with the line ferrod for the affected line are not restored. In addition, a trouble indication is printed on the office local-maintenance or the automatic-line-insulation-test teletypewriter.

A similar procedure is followed when ringing a line. In both cases, the actions followed ensure that the remreed network T and R contacts are switched dry. However, there is a possibility that the cutoff contacts and associated 2A line ferrod, located in the 296-3C and 296-4C remreed switch packages, could be damaged. The damage to the cutoff contact is related to the amount of current it breaks or passes in the presence of the foreign voltage. The possible damage to the 2A line ferrod is discussed below.

The ferrod¹² is a current-sensing device operating on electromagnetic principles. It consists of a ferrite rod around which is wound a pair of solenoidal control windings. In addition, a single-turn interrogate winding and a single-turn readout winding are threaded through two holes in the center of the ferrite rod. The two single-turn windings are physically separated from the pair of control windings by a plastic bobbin. The plastic bobbin is so constructed that the pair of control windings are also separated from each other. In normal operation, the ferrod is energized by the flow of dc current through its control windings, however, it can also be energized by ac current in the control windings.

The 2A line ferrod is used to detect call originations. It supplies battery and ground to the tip and ring of all loop-start lines through remreed cutoff contacts. In the case of coin or PBX ground-start lines, the line-ferrod control windings are connected in series, and supply battery power to the ring conductor through the cutoff contacts. The nominal dc resistance of each control winding, part of a pair of control windings, is 685 ohms. The guaranteed control-winding energizing current is 10 mA dc and the nonenergized current is 5.5 mA dc. The ferrod does not respond to longitudinal currents when wired in a loop-start configuration.

5.4 Foreign potential on idle lines

When a longitudinally applied foreign potential exists on an idle line arranged for loop-start operation, the 2A line ferrod shunts the foreign current to ground. The current through the ferrod winding decreases with time because the control-winding resistances increase due to heating. This proceeds until the windings short. As the windings begin to short, the current increases rapidly to a level where the windings open (blow out). The failure characteristics of the 2A line ferrod is shown on Table VI. The blow-out current of the 2A line ferrod is approximately 3.2 A.

Table VI — Typical 2A line-ferrod failure characteristic

Foreign Potential (V, 60 Hz rms)	Initial Current in Control Winding Before Shorting (A, 60 Hz rms)	Shorting* Time (s)	Blow-out† Time (s)
120	0.18	35	185
140	0.21	23	57
220	0.33	9	15
380	0.58	4	8

* After 100 s ferrod appears energized.

† Blow-out at approximately 3.2 A (rms).

It has been observed that for longitudinal power crosses in which the time to shorting is greater than 100 seconds, the current through the control windings causes the ferrite magnetic structure to heat. When its Curie temperature is reached, it loses its switching characteristics, and appears energized. When this occurs, the system identifies the power cross as an origination and the cutoff contacts operate and break whatever power cross current is flowing. In a case of this type of false origination, the power cross will be detected by the CDPR.

If the power cross is metallic, and thus flows only through one winding (which is also applicable to ground-start operation), the ferrod will energize and register a false origination request within approximately 100 to 200 ms.

5.5 Foreign potential on active lines

When a power cross occurs, it can be assumed that many of the lines affected are active. Figure 3 shows the No. 1 ESS equipment units in an active connection for intra- and interoffice calls that are vulnerable to damage.

In both types of calls, line supervision is derived from a 1C-type ferrod associated with either the junctor or trunk circuit. Fault currents due to power crosses will be carried by the office cabling, network contacts and link wiring, and junctor- or trunk-circuit battery-feed inductors in series with their associated ferrod sensors to ground. Figure 11 shows the components in junctor and trunk circuits. The major current-limiting factors in an active connection are the dc resistances of the office cabling, battery-feed inductor, and ferrod sensor.

When a battery-feed inductor and ferrod sensor are subjected to carrying fault currents of sufficient magnitude, they will heat and short. When this happens, the only impedance that limits the fault current is the office cabling resistance. The maximum allowable office cabling resistance in No. 1 ESS is 100 ohms, 50 ohms in both the tip and ring conductors. Therefore, after the battery-feed inductor and ferrod sensor windings short, the minimum rms fault current flowing, due to a 267-V rms potential, is approximately 5 A. The lower 3-sigma breakdown limit of the carbon-block protector is 267 V rms. This current will flow in both the T and R conductors. The power-cross shorting characteristics of No. 1 ESS battery-feed inductors and associated ferrod sensor windings are shown in Table VII, and their blow-out characteristics in Table VIII.

5.6 Remreed-contact-failure mode

When closed, the 238A remreed contact has a quiescent remanent-flux level. The effects of passing high-fault currents, ac, dc, or surge,

TRUNK CIRCUIT
(SHOWING FERROD SUPERVISORY FEATURE)

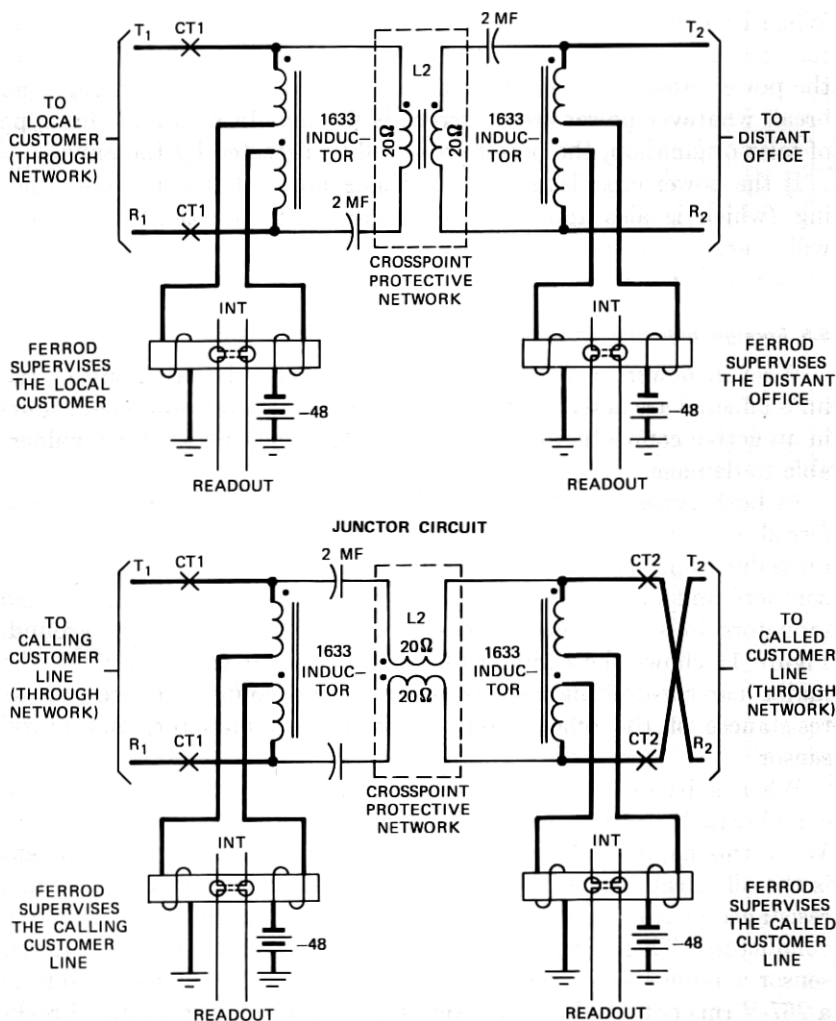

Fig. 11—Trunk circuit showing ferrod supervisory feature.

tend to reduce the remanent-flux level to a value equal to or less than the release-flux level and, therefore, cause the contact to open. Arcing, which occurs during opening, causes contact damage. In an active connection, there are eight contacts in series in both the T and R paths. The action of any one contact opening, due to high-current stress, will remove the fault-current return path and protect the remaining contacts. This action is significantly different from that

Table VII — Coil-shorting characteristic of line-supervision inductor and associated ferrod

Initial Fault Current (A, 60 Hz rms)	Shorting Characteristics	
	Longitudinal Cross Time (s)	Metallic Cross Time (s)
0.5	>100	—
0.6	40	250
0.7	30	70
0.8	25	55
0.9	20	40
1.0	16	32
1.1	13	25
1.2	10	20

experienced on sealed contacts, which are held closed by external remanent-flux fields, as is the case for ferreed crosspoints. These types of contacts would tend to repeatedly open and close and then weld when passing high-fault currents and this failure mode could propagate to all contacts in series. The remreed contact offers an improvement in this regard. In the case where the power-cross fault-current flows through remreed network contacts, the maximum fault current is limited to 3.2 A rms, which is the current magnitude where the contact opens.

Fortunately, the combined action of the remreed contact, transmission, and supervision components subjected to a power cross, taken as a whole, and the corresponding operational characteristics of the Nos. 1 and 1A ESS systems prevent fault currents of high magnitude from flowing in the network links and office cable for the relatively long periods required for the individual trunk components to blow out. The maximum fault current flowing in the network T and R conductors

Table VIII — Blow-out characteristics of line-supervision inductor and associated ferrod

Current (A, 60 Hz rms)	Blow-out Characteristics	
	Longitudinal Cross Time (s)	Metallic Cross Time (s)
2.5	—	—
3	1000	—
4	100	—
5	20	—
6	4	200
7	1	7

and contacts is 3.2 A rms and the maximum time this current flows is 42 seconds. The 3.2 A limit is controlled by the action of the 238A contacts. When open, the fault current stops. The 42-second time interval is related to the shorting time of the trunk- or junctor-circuit supervisory ferrod. When its control winding shorts (this occurs before the 3.2-A current level is reached) or the battery-feed inductor windings open, the ferrod deenergizes. The system will recognize this as a disconnect. Depending on system load, it will take from 11 to 42 seconds to open the cut-through contacts of the trunk or junctor circuit, removing all current paths to ground.

In addition to the current-carrying capability just described, the 238A remreed contact is designed to support, when open, a 900-V peak surge transient and 800-V peak, 60-Hz potential without breakdown.

5.7 Remreed switch and grid-link wiring

In the previous section, the remreed contact-failure characteristics were described. The remaining parts of the remreed network T-R paths are composed of switch printed-wiring planes and grid-link wiring. These interconnecting T-R links have been designed to carry foreign-potential currents in excess of 3.2 A rms without damage. They also are capable of supporting 900-V peak surge transients and 800-V peak, 60-Hz potentials without breakdown between T-R pairs or T-R conductors to ground.

VI. SUMMARY

In designing the remreed networks, special attention was given to the resulting transmission characteristics, and to assuring that they were sufficiently rugged to withstand the electrical stresses which they could encounter.

The geometries of the T and R conductors were carefully controlled to minimize susceptibility to interference, maintain a good balance to ground, and minimize insertion loss and distortion. As a result, the remreed networks provide excellent transmission quality in all present applications and are capable of supporting wideband analog and digital switching applications as they may arise in the future.

The design also assures that the remreed networks can withstand the normal operational stresses over their design lifetime and that they will survive most fault stresses without damage. Under very severe fault conditions, the design assures that failures will occur in an order which minimizes the loss of switching capability.

REFERENCES

1. R. R. Laane, "HILO—An Improved Transmission Scheme for Semiconductor Switching Networks," *B.S.T.J.*, 50, No. 3 (March 1971), pp. 1089-1093.
2. D. Danielsen and W. A. Liss, "Remreed Switching Networks for No. 1 and No. 1A ESS: Remreed Network Electronic Control," *B.S.T.J.*, this issue, pp. 565-595.
3. H. J. Klein, "Remreed Switching Networks for No. 1 and No. 1A ESS: Physical Design of Remreed Switching Networks," *B.S.T.J.*, this issue, pp. 607-636.
4. Bennison, Ghazi, Ferland, "Lightning Surges in Open Wire, Coaxial and Paired Cables," *IEEE Trans. Commun.* (October 1973), pp. 1136-1143.
5. R. J. Gashler et al., "Remreed Switching Networks for No. 1 and No. 1A ESS: Remreed Switches," *B.S.T.J.*, this issue, pp. 537-564.
6. W. E. Archer, K. M. Olsen, and P. W. Renaut, "Remreed Switching Networks for No. 1 and No. 1A ESS: Development of Remanent Reed Sealed Contact," *B.S.T.J.*, this issue, pp. 511-535.
7. J. G. Ferguson et al., "No. 1 ESS Apparatus and Equipment," *B.S.T.J.*, 43, No. 5, Part 2 (September 1964), pp. 2355-2439.
8. D. M. Mitchel, Investigation of the Breakdown Characteristics of 3-Mil Gap Carbon Protector Blocks," unpublished work, 1970.
9. D. H. Carbaugh et al., "No. 1 ESS Call Processing," *B.S.T.J.*, 43, No. 5, Part 2 (September 1964), pp. 2483-2531.
10. R. Biddulph et al., "Line, Trunk, Junctor, and Service Circuits for No. 1 ESS," *B.S.T.J.*, 43, No. 5, Part 2 (September 1964), pp. 2321-2353.
11. J. C. Kennedy, W. A. Liss, and J. R. Smith, "Remreed Switching Networks for No. 1 and No. 1A ESS: Remreed Line Scanner," *B.S.T.J.*, this issue, pp. 597-606.
12. L. Freimanis, A. M. Guerico, and H. F. May, "No. 1 ESS Scanner, Signal Distributor, and Central Pulse Distributor," *B.S.T.J.*, 43, No. 5, Part 2 (September 1964), pp. 2255-2282.

