

# THE BELL SYSTEM TECHNICAL JOURNAL

DEVOTED TO THE SCIENTIFIC AND ENGINEERING  
ASPECTS OF ELECTRICAL COMMUNICATION

Volume 54

February 1975

Number 2

Copyright © 1975, American Telephone and Telegraph Company. Printed in U.S.A.

## Echo Performance of Toll Telephone Connections in the United States

By F. P. DUFFY, G. K. McNEES, I. NÅSELL,  
and T. W. THATCHER, JR.

(Manuscript received June 18, 1974)

*A field survey to characterize echo performance of toll telephone connections was conducted in 1972. Information on echo path loss and echo path delay for talker echoes was obtained from a sample of nearly 1700 connections in the continental United States. This paper discusses the survey data acquisition techniques, the sample design, and the statistical results. A major result of the survey was the determination that echo path delay is significantly less than previously estimated. For the longest connections (2700 miles or 4345 km), the median round-trip echo delay is 45 ms, 11 ms less than previously calculated from the sum of connection segments.*

### I. INTRODUCTION

Echo may be experienced by talkers on long telephone connections when conditions exist analogous to those producing acoustic echoes, i.e., a two-way transmission path, a point of reflection, a perceptible time delay between transmission and reception, and received energy of sufficient amplitude to be detected. In the presence of a loud, long-delayed echo, whether acoustic or telephonic, conversation is likely to be difficult. Figure 1 is a simplified representation of a long-distance telephone connection with two-wire loops, four-wire trunk, and the hybrids (H) and balancing networks used in joining two-wire and four-wire circuits. The hybrids are the principal points of reflection in the telephone network. When a hybrid is perfectly balanced, none of

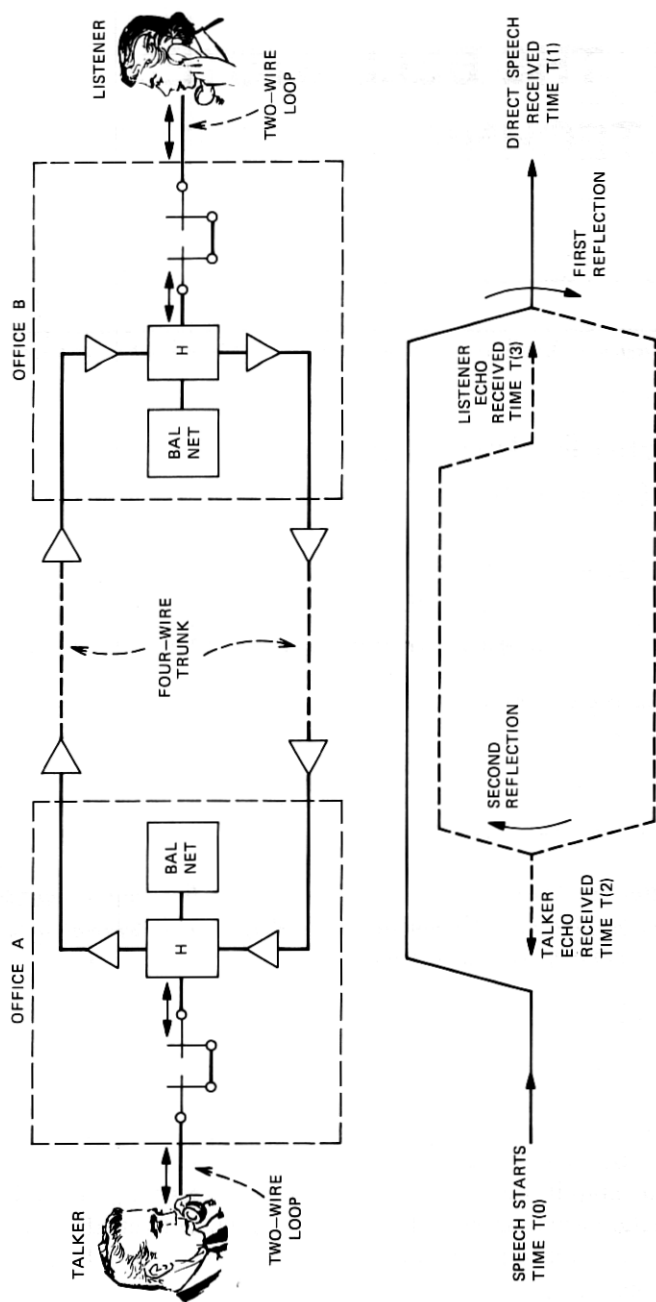

Fig. 1—Echo paths in a simple connection.

the energy from the receive pair of the four-wire path passes to the transmit pair. Since many different two-wire circuits, presenting a range of impedances, may be switched to a trunk while its associated balancing network remains fixed, some energy, which varies in amount from connection to connection, may be returned to the talker. Figure 1 also shows the direct and echo speech paths and their relative delay times. Only talker echoes are discussed here, since listener echoes are not significant when talker echoes are controlled to acceptable magnitudes.

Control of echo has been a concern of telephone engineers since long-distance telephone connections were made practicable by the introduction of low-distortion gain devices. The factors causing telephone echoes and most of the methods used since then to control echo were discussed by A. B. Clark in 1923.<sup>1</sup> These factors included the tolerance of talkers to echo as a function of echo amplitude and echo delay, the velocity of propagation of facilities, the degree of control of reflected signals at reflection points, and the choice of trunk losses to insure acceptable direct speech amplitudes while keeping echo amplitudes low. Another method of controlling echo that is presently used was soon added, the installation of echo suppressors on trunks having long echo delays to open the echo return path when speech is present in the direct path.<sup>2</sup> These measures, as appropriate, were applied to long toll trunks to control echo (from longer delayed reflections) and to short toll trunks to control singing and near-singing distortion (from shorter delayed reflections). The toll network trunking plan generally required only one or two short trunks and one long trunk to establish any long-distance connection. These trunk design methods for echo and singing control were continued from the 1920s through the 1940s, though with the passage of time knowledge of subscriber preferences was refined, impedance balancing was improved, new echo suppressors were developed, and carrier-type toll transmission facilities having propagation velocities approaching that of light were placed in service. These improvements permitted substantial reductions in the overall losses of long-distance connections.

A major change in echo design of toll trunks occurred in the late 1940s and early 1950s in conjunction with the change from operator to machine switching of toll calls, changes in the trunking plan allowing automatic alternate routing, and an increase to 7 in the maximum number of toll trunks in a long-distance connection. The Via Net Loss (VNL) plan was developed and implemented to assure acceptable echo performance on connections involving a few or many trunks, to provide low overall connection losses, and to avoid more than one echo suppressor on a long connection.<sup>3,4</sup>

In more recent years, attention has been given to new echo problems. The very long delayed echoes resulting from the transmission paths provided by communication satellites require changes in echo control measures.<sup>5</sup> The extension of speech transmission on digital facilities to greater and greater distances also will require new echo control measures. The T1 digital short-haul carrier system was introduced in the early 1960s, and its use continues to grow rapidly.<sup>6</sup> Long-haul digital trunk transmission systems are being developed.<sup>7</sup> The No. 4 ESS Toll Switching System will electronically switch digital bit streams to effect circuit switching.<sup>8</sup> Such digital arrangements will not easily permit adjustment of direct transmission loss on a trunk-by-trunk basis as specified by the VNL plan, and so require development of alternate methods of echo control.

Information was desired on the echo performance of the existing switched telephone network to provide an improved data base for echo control studies and planning, both for improvement of the present network and for evaluation of echo control measures proposed for digital networks. Information also was desired on whether there had been changes in subscriber reactions to echoes after some years of experience with low-loss long-distance connections.

This paper reports on the testing methods and results of a field survey to characterize the echo performance of the public switched-telephone network by making observations on a large sample of long-distance calls placed between many locations throughout the continental United States. The information obtained has been used to update mathematical models of echo performance of the telephone network. These models are being used in a variety of studies to evaluate results of changes proposed for the network. The echo survey disclosed that round-trip echo delays on the longer distance connections were shorter than had been predicted by older models. As a result of this and other information from the survey, the trunk lengths at which echo suppressors are installed have been increased, and significant cost savings are anticipated.

In this survey, observations were made on long-distance telephone connections extending from the local switching offices visited during the survey to distant called subscriber stations. The switching offices to be visited were selected using sampling techniques, copies of billing records were obtained, the billed calls were stratified by length into four mileage bands, and called numbers were randomly selected for the survey in each mileage band. Thus, the echo test calls repeated telephone calls previously made from the sampled offices. Figure 2 lists the sampled central office locations and shows the route traveled between locations.



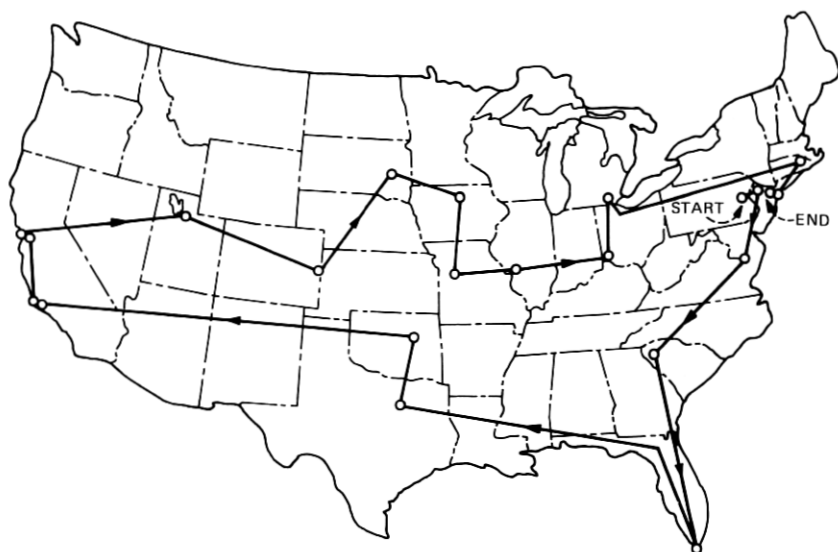

ALLENTOWN, PA.  
 ERSKINE LAKES, N.J.  
 HUGHESVILLE, MD.  
 BELTON, S.C.  
 MARATHON, FL.  
 DALLAS, TX.

TULSA, OK.  
 SANTA ANA, CA.  
 LOS ANGELES, CA.  
 HAYWARD, CA.  
 SAN FRANCISCO, CA.

SALT LAKE CITY, UT.  
 BURLINGTON, CO.  
 HURON, S.D.  
 MASON CITY, IA.  
 BOONVILLE, MO.

COLLINSVILLE, IL.  
 CINCINNATI, OH.  
 WAYNE, MI.  
 PROVIDENCE, R.I.  
 BROOKLYN, N.Y.  
 NEW YORK, N.Y.  
 (MANHATTAN)

Fig. 2—Echo survey tour route and cities visited.

Prior echo measurements<sup>9</sup> had been made only on portions of connection echo paths, e.g., trunk transmission facilities, trunk terminating equipment, and the return loss between trunks and loops and between trunks and other trunks. Statistical modeling techniques were used to derive echo path loss and echo path delay distributions for overall connections. The availability of new measuring techniques, minicomputers, and processing software made possible this first survey in which actual echo path loss and delay were determined on calling-end office to called-subscriber connections, with only the station and loop from the calling subscriber to his serving local office being excluded. Information is available from a loop survey<sup>10</sup> to refer echo path loss to the originating station, if desired.

Figure 3 shows schematically the subscriber stations, loops, switching offices, and trunks comprising a possible long-distance telephone connection. The figure also indicates locations where signals may be reflected back into a path leading to the point of origin, causing talker echoes. The figure shows only those talker echoes heard by subscriber W. However, since telephone connections have the same general

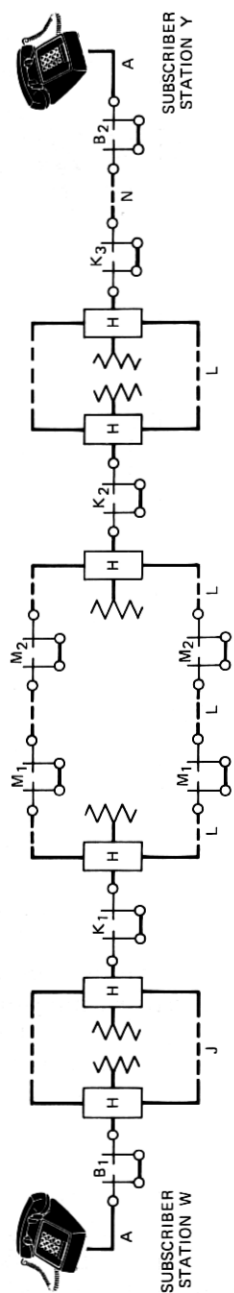

ECHO PATHS AND REFLECTION LOCATIONS

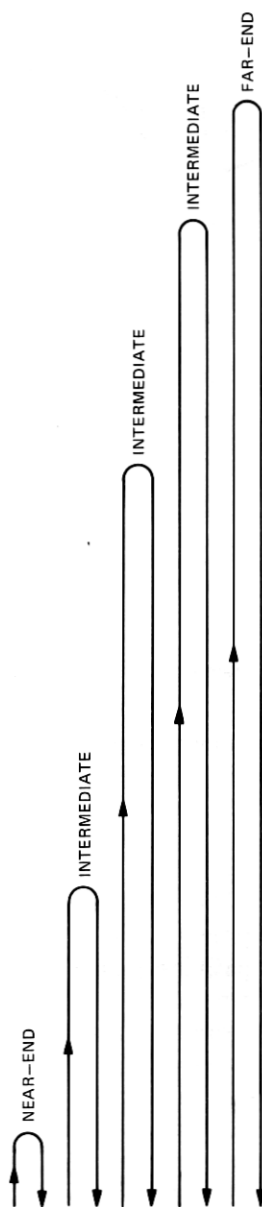

CONNECTION ELEMENTS

- A-LOOP
- B-LOCAL SWITCHING OFFICE
- H-TWO-WIRE TO FOUR-WIRE JUNCTION (HYBRID)
- J-FOUR-WIRE TOLL CONNECTING TRUNK
- K-TOLL SWITCHING OFFICE, TWO-WIRE
- L-FOUR-WIRE INTERTOLL TRUNK
- M-TOLL SWITCHING OFFICE, FOUR-WIRE
- N-TWO-WIRE TOLL CONNECTING TRUNK

Fig. 3—A possible toll connection and subscriber W talker echo paths.

structure at both ends, similar echoes of his own speech from reflection points throughout the connection (talker echoes) may be heard by subscriber Y. The characteristics of echo paths extending from the local office (B) adjacent to subscriber W to the distant end and back, shown as the far-end echo in Fig. 3, are reported here. The specific characteristics determined for each connection were the round-trip echo path loss and echo path delay.

In the following sections, the survey sampling plan is presented, the measuring technique and instrumentation are described, and the survey results are presented and discussed.

## II. SAMPLE DESIGN

The population about which information was desired was the set of toll calls originating in Bell System end offices and spanning an airline distance between originating and terminating local offices of 180 miles or more. Both originating and terminating ends of toll calls were confined to the continental United States. Toll calls shorter than 180 miles were excluded because the echo delay on these calls is short, and such short echoes are seldom perceived by subscribers.

The sampling plan used to select specific toll connections for field testing was a two-stage plan with primary stratification and substratification. The two-stage plan adopted has the advantage of limiting the number of locations to be visited for survey measurements. Bell System end-office buildings were identified as primary units of the sampling plan. Ten primary strata were formed. Each stratum was identified with the set of Bell System end-office buildings located in the area served by one of the ten regional centers in the DDD (direct-distance-dialing) network of the continental United States. The first-stage sample of primary units contained a total of 22 end-office buildings. Four primary units were selected from the White Plains region, and two were selected from each of the remaining nine regions. The first-stage sampling was made with probabilities proportional to estimates of size. The size of a primary unit was defined by the total number of outgoing toll calls based on billing records from the 1966 Message Minute Mile Study<sup>11</sup> and the 1964 Wire Center Study.<sup>12</sup>

The subjective effect of an echo is related to its delay, which is correlated with distance. This distance dependence influenced the structure of the sampling plan and resulted in the use of substratification. Four subclasses of toll calls were identified for data analysis purposes. They were defined on the basis of the airline distance between originating and terminating central offices. The four mileage bands were 180–360 miles (290–580 km), 360–725 miles (580–1167 km), 725–1450 miles (1167–2333 km), and 1450–2900 miles (2333–4667 km). The

purpose of the substratification was to give a sample of approximately equal size in each of these mileage bands. Four substrata were defined so that they approximately coincided with the four subclasses defined above. For convenience in the establishment of the second-stage sampling frames, the substrata were defined in terms of the numbering plan area (NPA) of the terminating end of a call rather than in terms of the exact distance between the end offices. Thus, if an NPA fell entirely inside one of the four mileage bands (measured from the originating end of the call), then all calls terminating in that NPA were referred to the corresponding substratum. If an NPA straddled the boundary between two mileage bands, then calls in that NPA were referred to the substratum that corresponds to the mileage band in which the majority of calls into the NPA were expected to terminate. This arbitrariness in the substratum definition does not affect the ability to analyze data with reference to each of the four subclasses defined. It has the advantage of avoiding the computation of the exact airline distance between originating and terminating central offices for the large number of calls listed in the second-stage frames.

Lists of outgoing toll traffic during one or more days were acquired from each of the 22 end office buildings comprising the first-stage sample. The lists covered one day's traffic for large offices and two or more days' traffic for small offices. The number of days was adjusted to give a sufficiently large listing of long toll calls. The substratification indicated above was imposed on each of the 22 lists. The second-stage sample of calls to be tested in the survey then was selected by simple random sampling. Independent selections were made in each substratum of each primary unit in the sample. Each second-stage sample element was identified with the telephone number of a called customer. The sample size was determined in such a way that the sample was approximately self-weighting in each of the four substrata (all observations contribute equally in calculating the statistical estimates within a mileage band). This self-weighting feature extended across all primary units within a specific substratum.

The sample size was determined on the basis of precision requirements and variance estimates. The precision requirements took the form of a maximum width of  $\pm 1$  dB for the 90-percent confidence interval of the mean echo path loss in each of the four mileage bands. Available data on variance components for the echo path loss were then used to derive the sample size. Successful transmission tests were completed on a sample of 1681 connections. Of these, 393 were in the first mileage band (180-360 miles), 470 in the second, 411 in the third, and 407 in the fourth mileage band.

All estimates given in Section V refer to the population defined above. The statistical estimation procedures used to derive the results were the appropriate ones for multistage-structured-sample surveys.<sup>13</sup>

### III. SURVEY INSTRUMENTATION

In planning the instrumentation of this field survey, goals were: (i) the measurement results will accurately represent the field conditions, (ii) the test equipment will perform reliably during use and after repeated shut-downs, moves, and start-ups at new test sites, (iii) the equipment design will permit its operation and relocation by technical staff personnel without requiring excessive time for training and hands-on experience, (iv) the operation will require a minimum number of persons, (v) the overall equipment operation will be monitored by built-in self-checking and operator-checking features, (vi) the output data will be in a form that will simplify subsequent processing and use, and (vii) the field travel and expense will be minimized. These goals were generally met. The methods used are briefly described in the next five paragraphs; greater detail is given in subsequent paragraphs.

The heart of the echo test set was a minicomputer. Software programs directed the testing sequences of translating stored test signals from digital to analog form for application to the sampled connections, and translation of the applied and echo return signals to digital form for recording on magnetic tape. These digital/time domain results were processed by a fast Fourier transform (FFT) program in the computer and translated to the frequency domain. Further processing (division by the transform of the transmitted signal) gave the frequency response of the entire connection echo path. The FFT was then used to translate to the time domain, giving the impulse response of the connection with the echoes separated in time. This permitted identification of the echo of interest, which then was transformed back to the frequency domain, giving the wanted output parameters-echo path loss and echo path envelope delay versus frequency for the selected far-end echo. The accuracy of the test set is determined by the gain in its input path and by the A/D (analog-to-digital) converter step size. Referred to the central office loop input, the quantizing noise from the A/D converter digital sampling is  $-84.6$  dBm, or  $5.4$  dBm, well below the telephone line noise. Thus, echo path loss values are bounded by telephone line circuit noise, not by test equipment characteristics.

The echo path test set was installed in a small van that was driven from site to site and parked by the sampled central office buildings.

Alternating-current power and telephone line connections were made between the van and the central office buildings. Setup, checkout, and calibration of the test equipment required only an hour or two. Figure 4 shows the equipment lineup within the test van.

The test set was put in operation by mounting program and data magnetic tapes and loading four command words or conditions into the computer via the computer console switches. Subsequent operational commands were entered via pushbuttons that lighted to indicate test status or available choice options. The software programs were written to provide checks of the steps involving operator actions, to provide automatic multiple attempts when tape reading errors were encountered, and to permit returns to the start of sequences in case of operator error. These arrangements permitted single-operator operation after a short training period. However, two-man test teams operated in the field on overlapping two-week assignments to provide continuity of testing throughout the day, to take care of other than measurement details, and to provide guided hands-on experience.

In operation, the called telephone number was dialed by a repertory dialer, there was a short conversation with the answering party in which the test was explained, the telephone number verified, and cooperation obtained. The subscriber was asked to cover the telephone transmitter with the palm of his hand to reduce room noise interference,

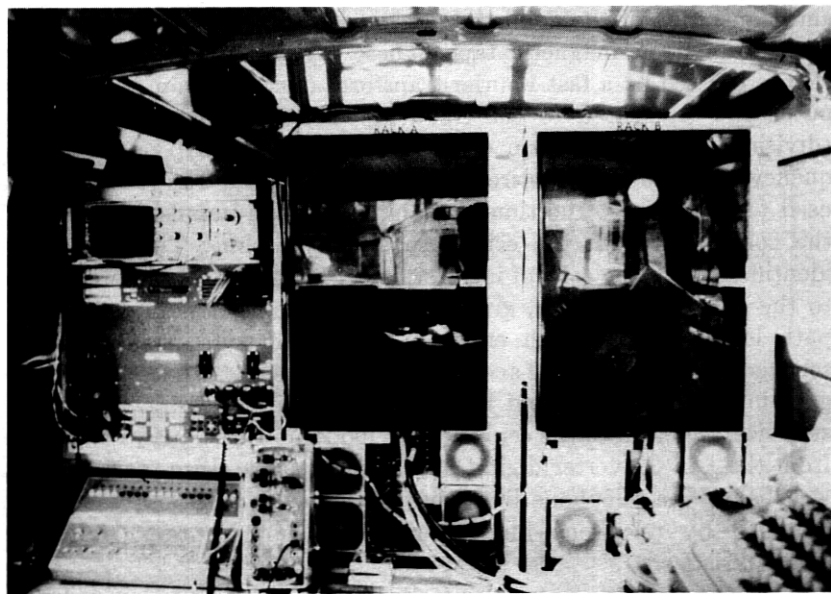

Fig. 4—Interior of test van.

the test tones were transmitted, the subscriber was thanked, and the call was terminated.

The echo path field data were recorded on magnetic tapes in standard data format to be compatible with large computers on which final processing was carried out after completion of the field portion of the survey.

### 3.1 Programmable test set

This section describes the hardware and software of the test set and its capabilities, which include analysis of observations and display of echo path loss and phase versus frequency. The principal information flow to and from the test set minicomputer is via digital-to-analog (D/A) and A/D converters. A block diagram of the test set is shown in Fig. 5. One magnetic tape unit is used to read stored programs and the other to record raw and processed data. The quantized interrogation signals stored in the computer memory as PCM binary words (part of the test program) are translated into a stair-step signal by the D/A converter and passed to the output low-pass filter (LPF), which reconstructs the original interrogation signals. Following the LPF is an attenuator used for setting the signal power transmitted to the local switching office. The talk-test switch connects the hybrid either to a dial/talk circuit for dialing a connection and talking to the subscriber or to the interrogation signal source. The hybrid is used to interconnect

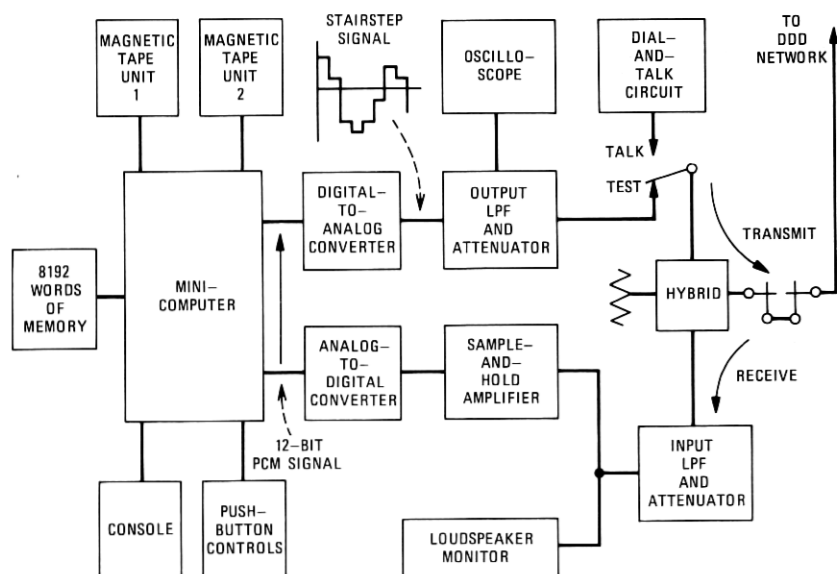

Fig. 5—Echo path test set.

the four-wire test set transmit-and-receive paths to the two-wire central office loop. In the receive path, the monitoring loudspeaker permits test personnel to verify transmission of the test signals. The LPF at the input to the sample-and-hold (S&H) amplifier is used to filter out frequencies higher than half the sampling rate. The S&H amplifier samples the incoming signal and holds the sample value constant while its A/D conversion is taking place.

The operator controls the test set by pushing buttons on the control panel to direct the test system to perform the various test or analysis operations. The control panel is also used to load numerical data in the test set and to display entered numbers and results of computations on a light-emitting diode (LED) display. The oscilloscope displays the transmitted signal and, following analyzation, the impulse, amplitude, or phase responses via the D/A converter.

As directed by the operator's pushbuttons, the computer's central processor unit executes various operational programs that are stored on magnetic tape and in core memory. These programs are overlaid in core memory from tape as they are needed by a monitor program<sup>14</sup> that always resides in the core memory.

### **3.2 Measurement of network impulse response by deterministic source interrogation signal**

A number of methods were investigated for determining the impulse response of networks. The one chosen for the echo survey used a deterministic signal comprised of a finite number of evenly spaced frequency components spanning the frequency band of interest, whose phases were specified to obtain a minimum signal amplitude peak-to-average ratio.

The impulse response,  $h(t)$ , of a network can be found by first calculating its frequency response,  $H(\omega)$ , and then computing the inverse Fourier transform of  $H(\omega)$ .

$$h(t) = F^{-1}[H(\omega)].$$

A sample value of the frequency response can be calculated by applying a sine wave to the input of the network, determining the resulting output, and dividing the output by the input. Thus, if  $X(\omega_i)$  is the input signal at frequency  $\omega_i$  and  $Y(\omega_i)$  is the output signal resulting from this input, then  $H(\omega_i)$ , the network response at  $\omega_i$ , is

$$H(\omega_i) = Y(\omega_i)/X(\omega_i).$$

For a linear time-invariant network (essentially attained by the



testing method), the principle of superposition holds and the observations can be made simultaneously at all frequencies  $\omega_i$  of interest.

The period of the lowest-frequency sine wave used was made to exceed the maximum expected delay of the network to avoid the ambiguity caused by one cycle of a sine wave being indistinguishable from the next. Since the maximum expected round-trip delay, based on models of the telephone network, was less than 60 ms, the test signal was designed to have a period of about 100 ms. This allows for a 40-ms duration of the impulse response of an echo delayed 60 ms. It follows, from the frequency sampling theorem,<sup>15</sup> that a signal essentially time-limited to 100 ms is completely specified by samples every 10 Hz. These samples in the frequency spectrum should cover the entire spectrum of interest, 200 to 3400 Hz, plus an additional upper band in which the energy can be reduced to zero using realizable filtering techniques. The transmitted interrogation signal,  $x(t)$ , was made up by summing 390 sine waves from about 10 Hz up to about 3800 Hz spaced approximately 10 Hz apart so that

$$x(t) = C \sum_{i=1}^{390} \cos [\omega_i t + \phi_i].$$

The amplitude distribution of the resulting interrogation signal  $x(t)$  depends on the relative phases  $\phi_i$  chosen for the component sine waves. This waveform can range from a very peaked impulse, when all the components are in phase, to a signal that has a relatively low peak-to-rms ratio for certain other phase relationships. Since there are many devices in the echo path that could overload and cause nonlinear distortion, such as amplifiers and syllabic compressors, a signal that has the least peak-to-rms ratio is desirable. When the phases of the component sine waves are proportional to the square of their frequencies, the peak-to-rms ratio is minimized.<sup>16</sup> The phases,  $\phi_i$ , in the interrogation signal are given by

$$\phi_i = i^2/390.$$

The resulting sum of all the components is a good approximation to frequency modulation of a carrier with a sawtooth waveform. At the beginning of the approximately 100-ms sweep period, the energy is centered around 3800 Hz and linearly decreases in frequency with time to around 10 Hz at the end of a period. Figure 6 shows the waveform of one period of the interrogation signal.

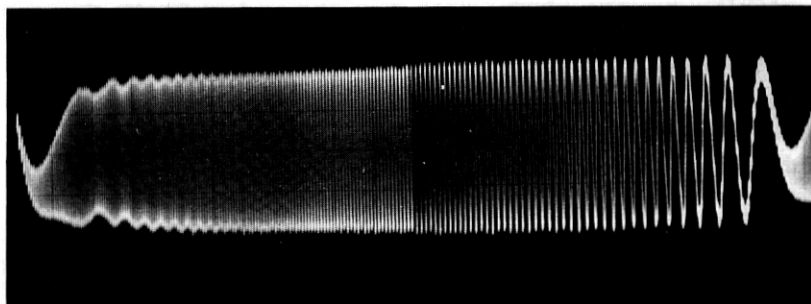

Fig. 6—One 102.4-ms period of the interrogation test signal.

#### IV. DATA ACQUISITION AND PROCESSING

##### 4.1 Examples of echo path characteristics

The impulse response of an overall long-distance connection includes the impulse response of the near-end and intermediate paths as well as that of the desired far-end echo path. The occurrence of such echoes is depicted in Fig. 3. To obtain the wanted far-end echo path characteristics, the energy reflected from the far end must be separated from that reflected from near-end and intermediate discontinuities. This can be done only if the reflections are sufficiently separated in time.

Figure 7a shows the impulse response of an actual connection in which near-end and far-end echoes were the significant contributing

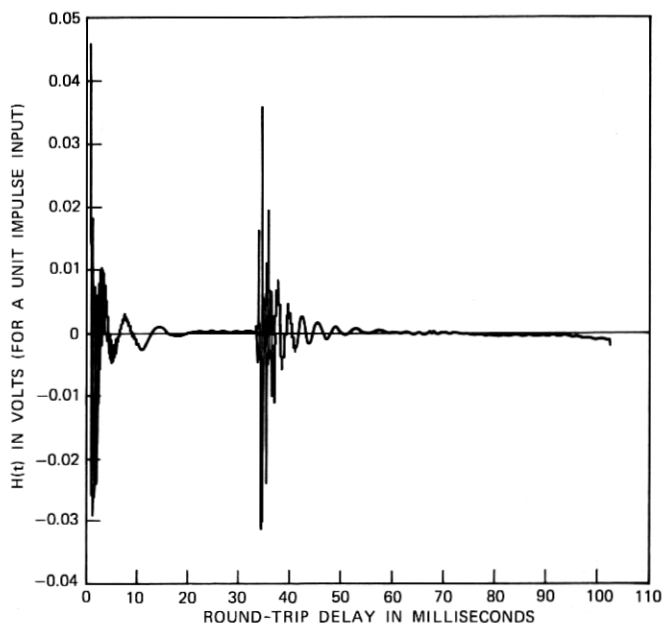

Fig. 7a—Impulse response of a telephone connection.

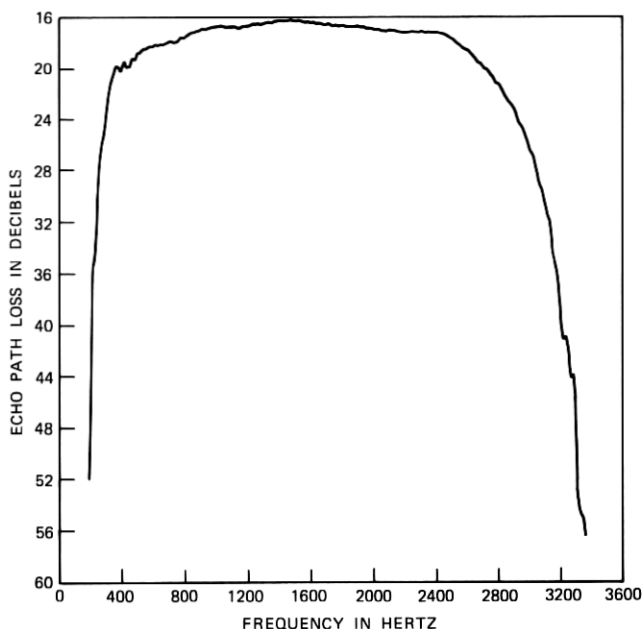

Fig. 7b—Far-end echo path loss of a telephone connection versus frequency;

elements. To obtain the echo path characteristics of the far-end echo alone, the amplitude values of the first impulse response (from the near-end discontinuity, 0 to 30 ms) are set equal to zero. The inverse transform is then taken, giving the amplitude and delay characteristics of the second or far-end impulse response that characterize the echo path. Figure 7b shows the far-end echo path amplitude response and Fig. 7c the envelope delay response (the derivative of the phase response) for the connection.

Figures 8a, 8b, and 8c show the impulse response, echo path amplitude, and envelope delay response of a connection with several reflections at the far end that could not be separated. The ripples versus frequency in the amplitude response result from the relative phasing of the components from two reflections. Large nulls occur when the two reflected components are nearly equal and 180 degrees out of phase. These correspond to absorption bands, and in these regions the actual delay is not equal to the envelope delay.<sup>17</sup> In such instances, delay values for the connection were taken from smooth curves that continued the trends adjacent to the absorption bands.

#### 4.2 Data processing during and after acquisition

Basic to processing of the echo data is the discrete Fourier transform (DFT).<sup>18</sup> The fast Fourier transform algorithm for calculating

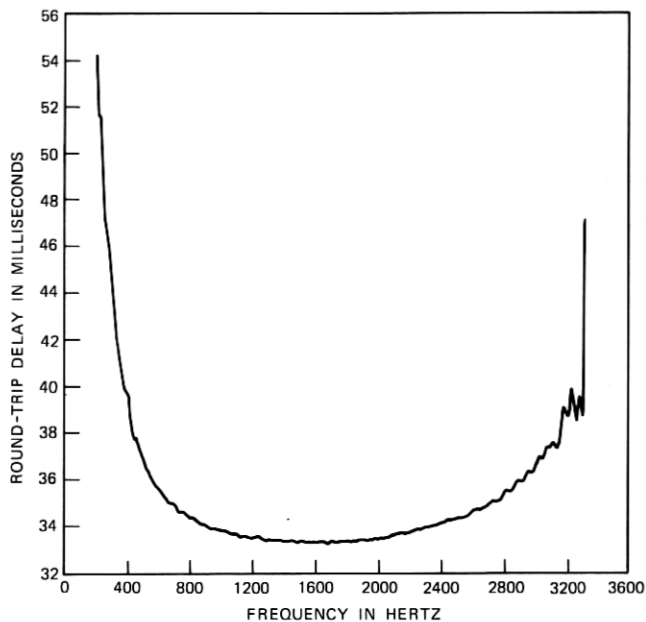

Fig. 7c—Far-end echo path envelope delay of a telephone connection versus frequency.

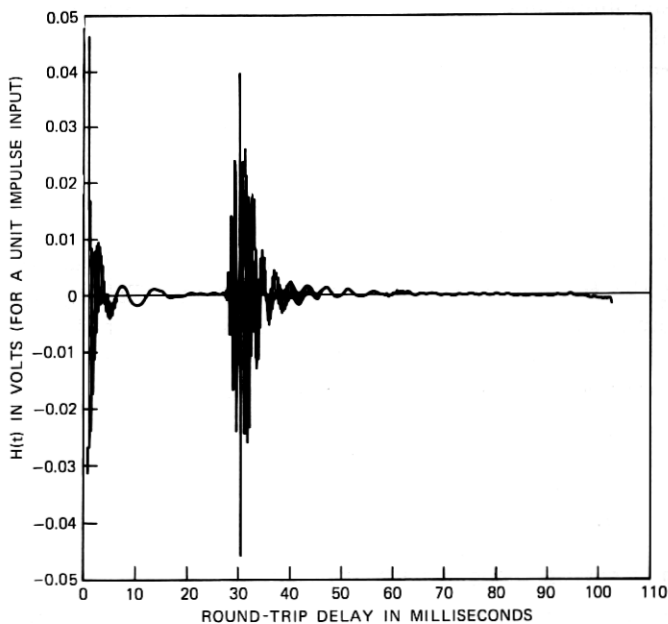

Fig. 8a—Impulse response of a telephone connection with multiple far-end echoes.

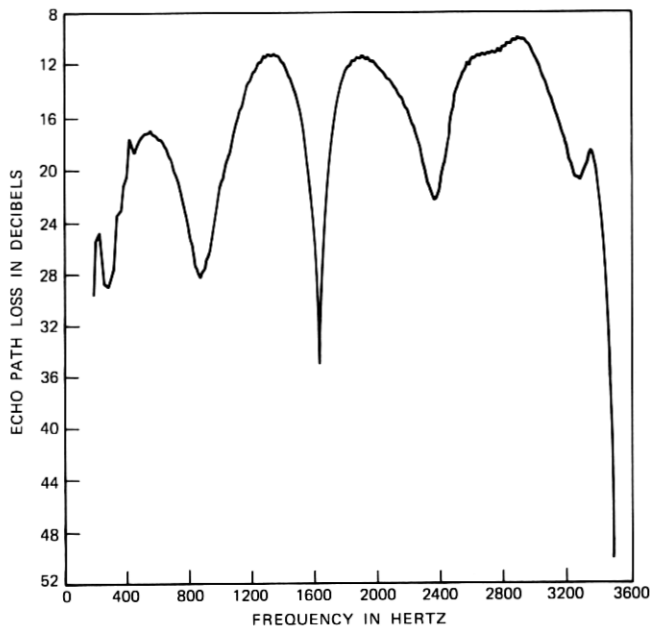

Fig. 8b—Far-end echo path loss of a telephone connection versus frequency; multiple echoes present.

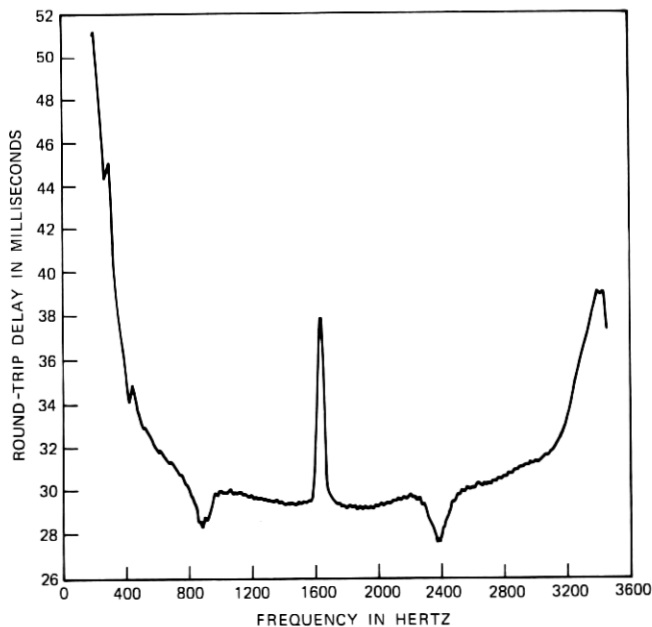

Fig. 8c—Far-end echo path envelope delay of a telephone connection versus frequency; multiple echoes present.

the DFT is most efficient if the number of data points to be transformed is an integral power of two. As previously mentioned, to measure delays of 100 ms the fundamental frequency should be about 10 Hz. The sampling rate for the converters was set to 10 kHz to allow some margin against aliasing of the voice-band measurements. For a 1024-point transform, a maximum period of 102.4 ms is possible, which meets our objective and gives a fundamental frequency  $F_0 = 10000/1024 = 9.765625$  Hz. The bandwidth of the echo paths is less than 3300 Hz<sup>19</sup> and, therefore, to cover the spectrum, the interrogation signal consisted of the sum of 390 sine waves spaced every 9.765625 Hz up to 3808.59375 Hz. The digital amplitude samples of the interrogation signal stored in the test set were preshaped to take into account the  $(\sin x)/x$  weighting caused by using finite width samples instead of impulses to reconstruct the continuous wave.<sup>20</sup> Thirty-five periods of the interrogation signal were sent and, since each period lasts 102.4 ms, the test signal lasted 3.574 seconds. Received signals recorded simultaneously with transmission of the last 32 periods of the test signal were processed during data reduction. The time elapsing during transmission of the first three periods permitted any syllabic companders present in the connection to reach equilibrium and transients to subside. The first step in signal processing was averaging of amplitude samples over the 32 signal periods, which improved the signal-to-noise ratio by 15 dB.

Although the desired echo path response is band-limited to less than 3300 Hz by filters in the facilities making up the trunks,<sup>19</sup> the reflected energy resulting from near-end discontinuities is not band-limited in this manner and normally will extend beyond 3800 Hz. The result of measuring a network whose bandwidth exceeds the bandwidth of the interrogation signal is equivalent to truncating the spectrum describing the wider bandwidth network, or measuring with these impulse response techniques an ideal low-pass filter in tandem with the desired network. This substantial discontinuity in the frequency spectrum causes Gibb's phenomenon<sup>21</sup> in the impulse response. To avoid this distortion, the returned signal was further digitally filtered by a 3400-Hz low-pass filter (DLPF) to assure that the response dropped off sufficiently at 3800 Hz. The DLPF loss characteristic is included in the response shown in Fig. 9a, where echo path loss versus frequency for the test set is shown. The high-frequency roll-off is determined entirely by the DLPF. This response is a calibration check for a 100-percent reflection (open circuit at the loop side of the hybrid) and thus includes all frequency weighting by the test set. Figure 9b is the envelope delay response of the calibration test.

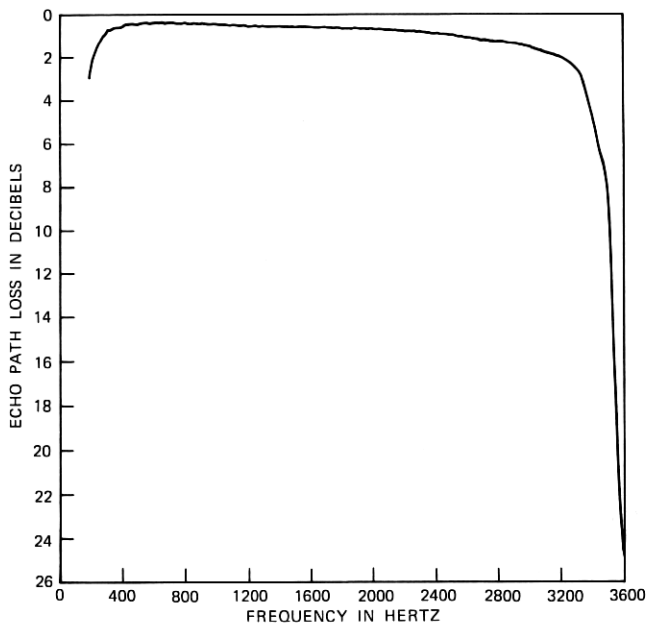

Fig. 9a—Frequency response of the echo path test set for a 100-percent reflection calibration test.

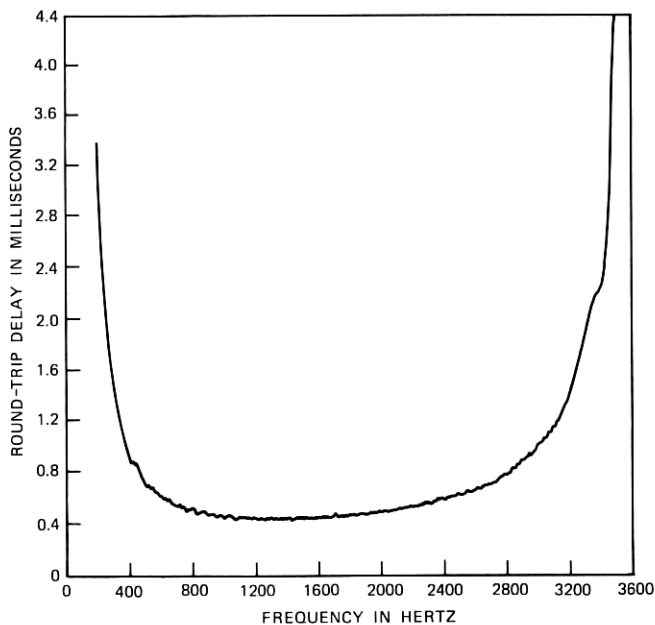

Fig. 9b—Envelope delay of the echo path test set for a 100-percent reflection calibration test.

Immediately following transmission of the 35-period interrogation signal, a 2109-Hz tone\* was sent for 409.6 ms to disable echo suppressors that may have been present in the connection, and the interrogation signal was transmitted a second time. If an echo suppressor were present in the connection, it would have opened the return path and suppressed the echo from the far end during the first interrogation signal transmission. Sending the echo suppressor disabling tone made the echo suppressors inoperative, which kept the return path connected so that the echoes from all portions of the connection were recorded the second time the interrogation signal was sent.

The last 32 periods of the interrogation signal were averaged and then transformed by the FFT during processing of the recorded data. These transformed data were multiplied by the transform of the 3400-Hz DLPF mentioned above. The filtered data were then divided by the transform of the transmitted interrogation signal to obtain the system function of the connection modified by the filter. The inverse FFT was then computed, and the resulting impulse response was stored on magnetic tape. Both sets of data, with echo suppressors enabled and disabled, were processed. When this was completed, control was returned to the operator, and he could observe either impulse response on the oscilloscope. After viewing the impulse response, he could set to zero those portions of the response he desired to omit, and the test set would compute the spectrum of the echo path of interest. Upon completion of the transformation, either the amplitude spectrum or the phase response could be displayed on the oscilloscope. In addition, the minimum loss value and the average loss for the 500- to 2500-Hz band were displayed on the LED display. All calibration measurements, and periodically a test measurement, were processed in this manner to verify proper test set performance.

After the field survey was completed, processing was carried out on large-scale batch processing computers at the Holmdel location of Bell Laboratories. The echo path loss and phase were calculated, and test set characteristics were subtracted. In addition, the absolute envelope delay was calculated from the phase response, and microfilm graphs were created of all responses. The results were screened for errors, consistency checks were made, and the processed data were analyzed to obtain the results presented in Section V.

---

\* In establishing a path through the DDD network for data transmission, a tone in the band 2010 to 2240 Hz is transmitted briefly just before application of the data signals to disable echo suppressors and permit simultaneous two-way transmission (Ref. 22).



## V. ECHO PATH CHARACTERISTICS—DATA ANALYSIS RESULTS

The echo path loss and echo path delay discussed in the following sections are described in terms of means, standard deviations, and cumulative distribution functions. Each estimate of a population mean is accompanied by a 90-percent confidence interval to indicate the uncertainty because of sampling. Scatter diagrams and plots of cumulative distribution and probability density functions are used to illustrate data behavior in specific instances.

As stated in Section I, test connections originated from local switching offices and terminated at subscriber stations. All data have been adjusted to remove the influence of the lines used to connect the test equipment to the local switching offices and that of the testing equipment itself. Thus, results given in the following sections apply to connections having loops of zero length and 0-dB loss at the originating ends. Since test connections terminated at subscriber stations, customer loops were encountered at the far ends.

### 5.1 Loss characteristics of echo paths

Loss is intentionally introduced into the transmission path of a telephone connection to control echo performance, as previously noted. The total loss is allocated to various segments of the transmission path according to the Via Net Loss plan adopted by the Bell System in the early 1950s.<sup>3,23</sup> The goal of that design is to provide enough loss to control echo performance and simultaneously to insure adequate received levels for satisfactory direct transmission between subscribers.

#### 5.1.1 Losses for far-end echoes

Three measures of echo path loss were extracted from each amplitude response characteristic. These are (i) the unweighted average echo path loss in the frequency band 500 to 2500 Hz, (ii) the echo path loss at 1000 Hz, and (iii) the minimum echo path loss. The average loss in the 500- to 2500-Hz band was calculated on the power scale over those test signal frequencies that fell within the indicated frequency band. This measure of echo path loss is used to evaluate subjective reaction to talker echoes in the telephone network. All three measures are discussed in this section.

Results of a statistical analysis of data for these three loss characteristics are tabulated in Table I. Echo suppressors were disabled when the information to calculate these loss characteristics was recorded.

The 500- to 2500-Hz echo path loss for far-end echoes is, on the average, 23.8 dB. Its distribution is approximately normal with a

**Table I — Losses for far-end echo paths on toll telephone connections (echo suppressors disabled)**

Connection Length (Airline Miles)	500- to 2500-Hz Echo Path Loss		1000-Hz Loss		Minimum Loss	
	Mean (dB)	Std. (dB)	Mean (dB)	Std. (dB)	Mean (dB)	Std. (dB)
180-2900	23.8 ± 1.9	6.3	26.2 ± 1.6	7.6	19.4 ± 1.8	5.8
180-360	23.1 ± 1.6	5.7	25.2 ± 1.5	7.0	18.7 ± 1.6	5.3
360-725	24.3 ± 2.2	6.8	26.8 ± 1.9	8.0	19.8 ± 2.0	6.3
725-1450	24.6 ± 2.2	6.3	27.2 ± 1.9	7.9	20.1 ± 2.0	5.7
1450-2900	23.3 ± 2.1	6.4	25.9 ± 1.8	7.6	18.9 ± 1.9	5.9

standard deviation of 6.3 dB. Table I shows that the estimated mean echo path losses increase slightly with increasing connection length in the first three mileage categories and the mean loss decreases slightly in the last one. This dependence upon connection length, while not statistically significant, probably results from application of the Via Net Loss plan to trunks used to establish connections. The trunk design loss under that plan is dependent upon the length of the trunk and is an increasing function of trunk length for trunks less than 1565 miles long. Echo suppressors were required on trunks longer than 1565 miles at the time the survey tests were made. Trunks containing an echo suppressor have a design loss of 0 dB. Although trunks are placed in tandem to establish connections, and airline distances instead of total trunk lengths are used to present the results in Table I, the overall influence of the Via Net Loss plan seems apparent in these estimates.

The estimated mean echo path loss at 1000 Hz exceeds the estimated mean 500- to 2500-Hz echo path loss by 2.4 dB, while the estimated standard deviation is larger by 1.3 dB. The difference in standard deviations is caused by ripples in the amplitude responses for some far-end echo paths (see Fig. 8b). These were caused by two or more reflections at the far end that could not be separated on some test connections. The 1000-Hz echo path loss is approximately normally distributed.

The estimated mean minimum echo path loss is 4.4 dB less than the estimated mean 500- to 2500-Hz echo path loss, and the estimated standard deviation is 0.5 dB smaller. The standard deviation is smaller because the minimum losses are less influenced by ripples in the amplitude responses. The distribution for minimum echo path loss is close to normal.

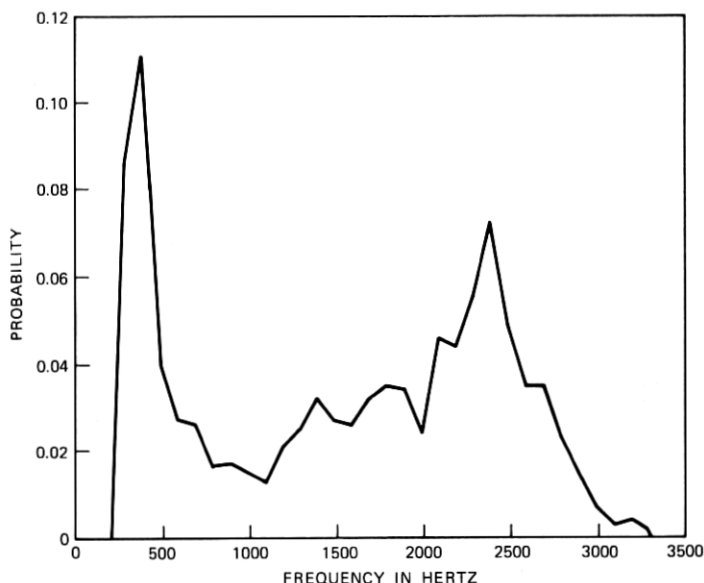

Fig. 10—Estimated probability density for the frequency at which minimum echo path loss occurs for far-end echoes.

The frequency at which the minimum echo path loss occurred was determined for each test connection. The estimated probability density for minimum echo path loss frequency is given in Fig. 10. This density function shows that the distribution is bimodal. The mode for low frequencies occurs around 400 Hz and the mode for high frequencies around 2400 Hz. When singing occurs because of excess gain on a connection, it usually is at frequencies between 200 and 500 Hz or 2500 and 3200 Hz. The bimodal behavior illustrated in Fig. 10 is in good agreement with that observed phenomenon.

### 5.1.2 Influence of echo suppressors

At the time field tests were conducted, echo suppressors were required on interregional intertoll trunks greater than 1565 miles long and on most intertoll trunks directly connecting regional-center toll-switching offices.<sup>4</sup>

Table II shows that 18 percent of toll connections longer than 180 airline miles contain an echo suppressor. When considered by mileage category, the table shows that essentially no echo suppressors are found on connections shorter than 725 airline miles. An estimated 25.4 percent of the connections belonging to the 725 to 1450 airline-mile category contain an echo suppressor. The airline distance between

Table II — Echo suppressor usage and operation on toll telephone connections

Connection Length (Airline Miles)	Percent Encountering Echo Suppressors	Far-end Echoes 500- to 2500-Hz Echo Path Loss			
		E. S. Disabled		E. S. Enabled	
		Mean (dB)	Std. (dB)	Mean (dB)	Std. (dB)
180-2900	18.0 ± 2.6	23.8 ± 1.9	6.3	28.9 ± 2.4	12.1
180-360	0	23.1 ± 1.6	5.7	23.2 ± 1.6	5.6
360-725	0.4 ± 0.3	24.3 ± 2.2	6.8	24.3 ± 2.2	6.8
725-1450	25.4 ± 5.1	24.6 ± 2.2	6.3	31.4 ± 3.5	11.9
1450-2900	90.1 ± 1.7	23.3 ± 2.1	6.4	49.2 ± 2.4	10.9

originating and terminating local switching offices is substantially less than the total trunk length for many connections. The locations of toll switching offices, alternate routing in the network, and the physical routes of transmission facilities between switching offices contribute to these differences between airline and actual connection lengths. Thus, some connections in this category may contain intertoll trunks greater than 1565 miles in physical length; others could contain intertoll trunks connecting two regional center switching offices. An estimated 90.1 percent of the connections in the longest mileage category contain an echo suppressor. The switching of intertoll trunks in tandem in a telephone connection accounts for some of these connections not having echo suppressors. Some may have had echo suppressors that did not suppress properly. These reasons account for the absence of echo suppressors on approximately 10 percent of the long connections. It was also estimated that 5.4 percent of echo suppressors did not respond to disabling tones.

Figure 11 is a scatter diagram of 500- to 2500-Hz echo path loss with echo suppressors disabled versus connection length in airline miles between originating and terminating local switching offices. Figure 12 is the corresponding scatter diagram of echo path loss with suppressors enabled. A comparison of these diagrams illustrates the influence of echo suppressors. Echo path loss is substantially increased on long connections when echo suppressors are enabled, while it remains unchanged for short connections that generally do not contain echo suppressors. Results for echo path loss with and without echo suppressors are listed in Table II. The presence of echo suppressors on connections in the last two mileage categories increases the mean echo path loss.

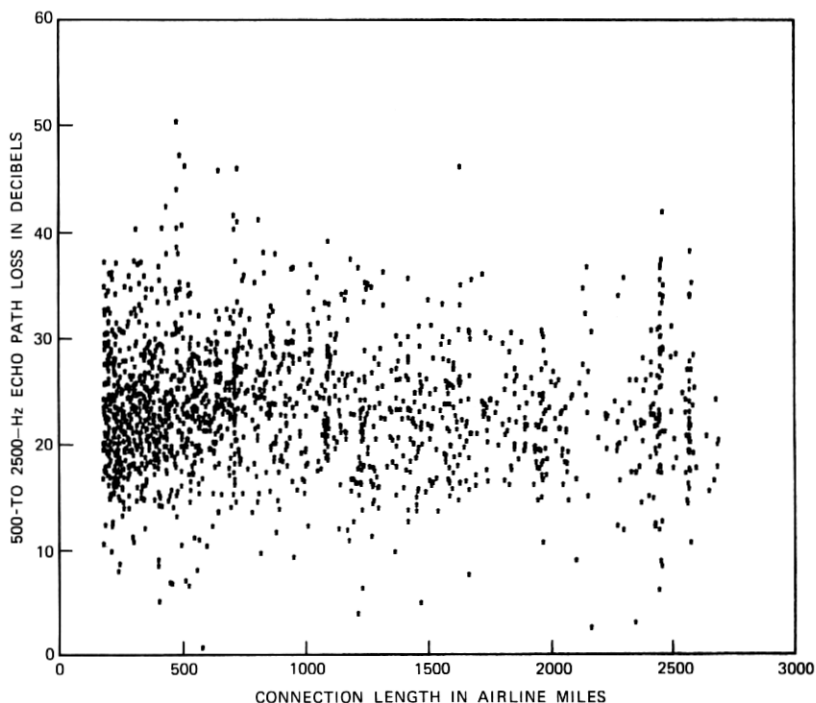

Fig. 11—Scatter diagram of far-end echo path loss on toll telephone connections with echo suppressors disabled versus connection length.

In many cases, the test signal was so highly attenuated by echo suppressors that only line noise was observed. The mixture of connections with and without echo suppressors accounts for the high standard deviations in the last two mileage categories. Figure 13 shows that the distribution of echo path loss with echo suppressors disabled is close to normal, while operation of echo suppressors causes positive skewness in the echo path loss distribution. Though not illustrated, the distribution for echo path loss with echo suppressors enabled is positively skewed in the third mileage category and negatively skewed in the fourth. The positive skewness in the third mileage category is caused by the 25 percent of the connections that contain echo suppressors. The negative skewness in the fourth category is caused by the 10 percent of the connections that do not contain echo suppressors.

Figure 14 graphically displays the suppression introduced by echo suppressors. The 500- to 2500-Hz echo path loss with echo suppressors disabled is plotted against the echo path loss with suppressors enabled. In cases where telephone connections did not contain echo suppressors,

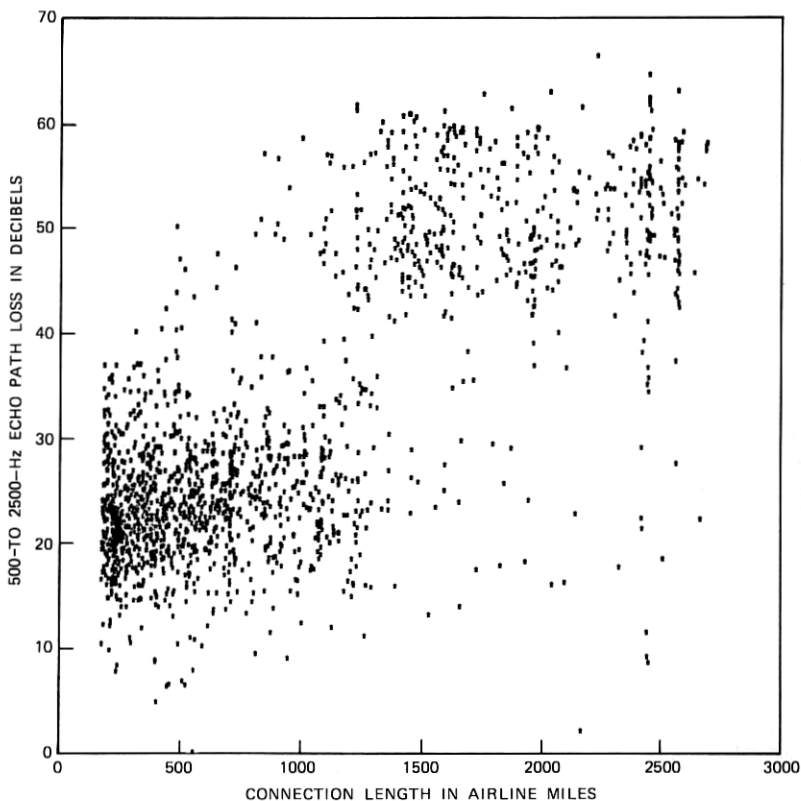

Fig. 12—Scatter diagram of far-end echo path loss on toll telephone connections with echo suppressors enabled versus connection length.

the two losses are close to being identical. These points in the figure lie about a line with a slope of  $+1$  passing through the origin. In cases where properly functioning echo suppressors were encountered, the points lie well to the right of that line. An analysis of the data for connections that contained echo suppressors shows that the average additional loss inserted by the echo suppressors is greater than 28.4 dB and that this detectable additional loss is normally distributed with a standard deviation of 7.6 dB. In most cases, echo suppressors attenuated the reflected test signals to such an extent that they were below the noise present on the connections. In these cases, the actual losses with suppressors enabled were obscured by the circuit noise. Because of this, the estimated average additional loss inserted by echo suppressors is a lower bound on the average amount of suppression actually introduced.

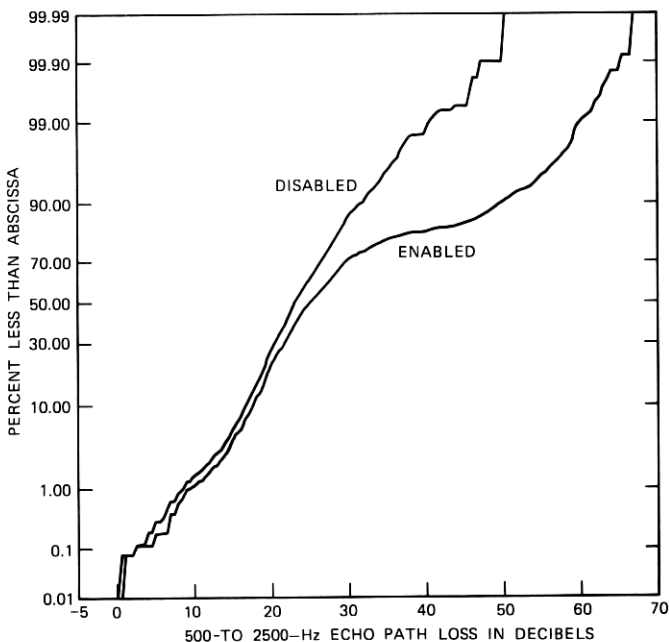

Fig. 13—Distributions of far-end echo path loss on toll telephone connections, with and without echo suppressors enabled.

## 5.2 Delay characteristics of echo paths

In voice transmission for a given echo path loss, the subjective disturbance caused by talker echo increases as receipt of the echo is increasingly delayed in time.<sup>1-4</sup> This delay is primarily determined by the length of the transmission path traversed, by the physical transmission media encountered, and by the number of modulation-demodulation steps associated with the individual transmission facilities encountered. Echo path delay on toll telephone connections is discussed in the following sections.

### 5.2.1 Delays experienced by far-end echoes

In Section I it was noted that echo path delay is the round-trip transmission delay experienced by an echo. This delay was computed from the impulse responses at approximately 10-Hz intervals across the voice frequency band. 1000-Hz and minimum echo path delays are discussed in this section. The minimum echo path delay may occur at different frequencies for different echo paths. The frequency at which the minimum occurs is also discussed.

Estimates of echo path delay are listed in Table III. The estimated average 1000-Hz delay is 19.5 ms for connections longer than 180 air-

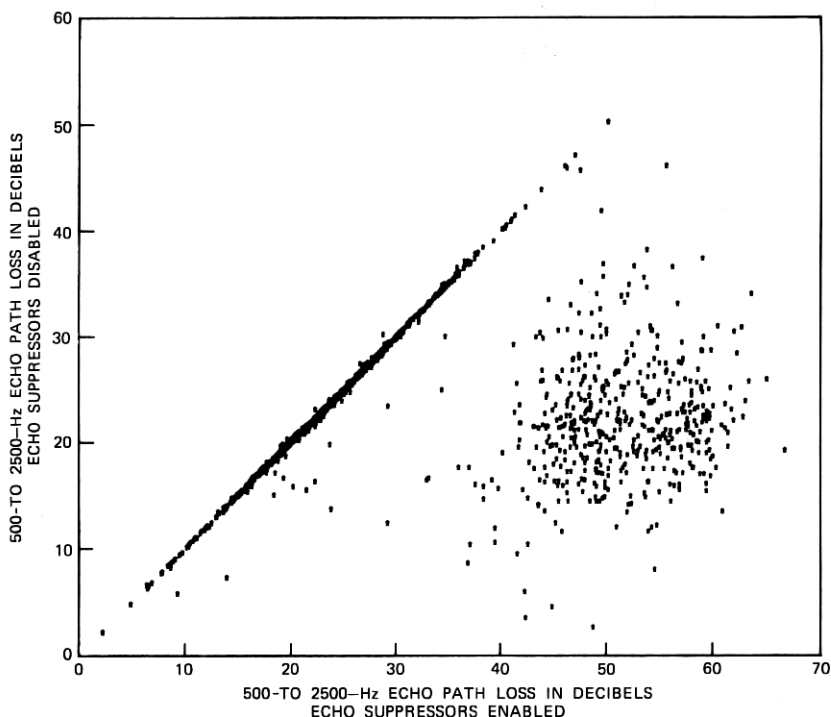

Fig. 14—Scatter diagram of far-end echo path loss on toll telephone connections with echo suppressors disabled versus echo suppressors enabled.

line miles. The distribution of 1000-Hz delay has an estimated standard deviation of 9.5 ms. Figure 15 shows that the distribution is truncated at about 5 ms in the lower tail, due to exclusion of toll connections shorter than 180 miles, and is highly skewed toward the positive direction.

Table III — Delays for far-end echo paths on toll telephone connections

Connection Length (Airline Miles)	1000-Hz Echo Path Delay		Minimum Echo Path Delay	
	Mean (ms)	Std. (ms)	Mean (ms)	Std. (ms)
180-2900	19.5 ± 0.9	9.5	18.5 ± 0.9	9.4
180-360	11.7 ± 0.8	3.4	10.6 ± 0.7	3.2
360-725	16.4 ± 0.5	3.8	15.4 ± 0.7	3.6
725-1450	24.8 ± 2.1	5.0	23.7 ± 2.0	4.8
1450-2900	37.3 ± 1.3	6.1	36.2 ± 1.4	6.0



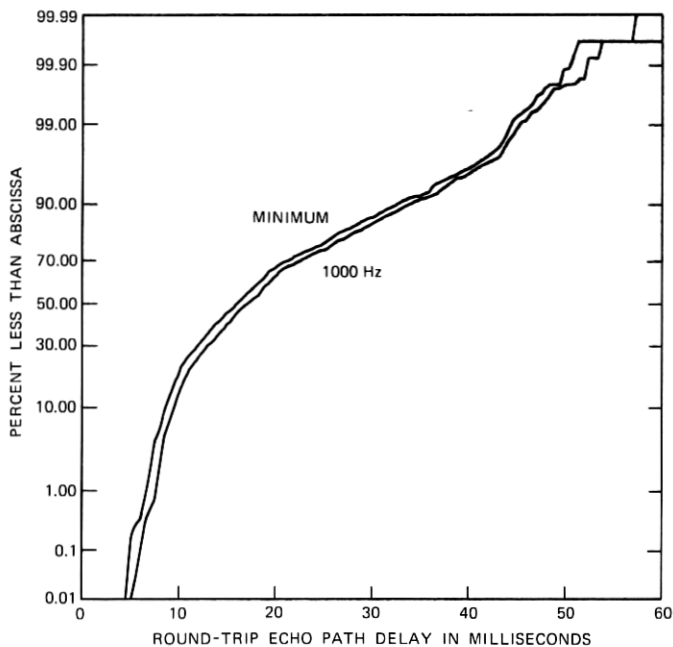

Fig. 15—Distributions of echo path delay on toll telephone connections for far-end echoes.

Average 1000-Hz delay increases monotonically with increasing connection length. This reflects the increased propagation delay required to travel greater distances and the increased likelihood of encountering more modulation-demodulation equipment on long connections. A previous study of intertoll trunks established that more channel bank pairs are found on long trunks than on short ones.<sup>24</sup> Alternate routing in the telephone network also accounts for an increased number of channel banks in long connections because more trunks are established in tandem to set up the connections. The standard deviation for 1000-Hz delay also increases with increasing connection length. The distribution of 1000-Hz delay in the shortest mileage subclass exhibits a high degree of positive skewness just as the overall distribution does. However, the distributions for the three remaining mileage subclasses are close to normal with slight deviations from normality found in the upper and lower tails.

Minimum delay closely follows the same trends discussed above for 1000-Hz delay. An analysis of the differences between the two delays calculated for each test connection estimates the average difference to be  $1.1 \pm 0.1$  ms. These delay differences are close to being normally distributed with an estimated standard deviation of 0.6 ms. The cumulative distribution for minimum delay is also plotted in Fig. 15.

This figure clearly shows the similarity between 1000-Hz and minimum delay.

In many instances, the echo path delay versus frequency curves are rather flat in the middle of the voice frequency band. Since the minimum delay generally occurs in that area of the band, the frequency of minimum delay was arbitrarily defined to be 1700 Hz in these cases. This occurred in approximately one-third of the observations. The average frequency of minimum delay is estimated to be  $1743 \pm 33$  Hz. The standard deviation is estimated to be 229 Hz.

### 5.2.2 Observed changes in echo path delay

Comparison of the current echo survey results with previously available information for echo path delay shows a noticeable decrease in the amount of transmission delay experienced in the telephone network. Figure 16 is a scatter diagram of the 1000-Hz echo path delay

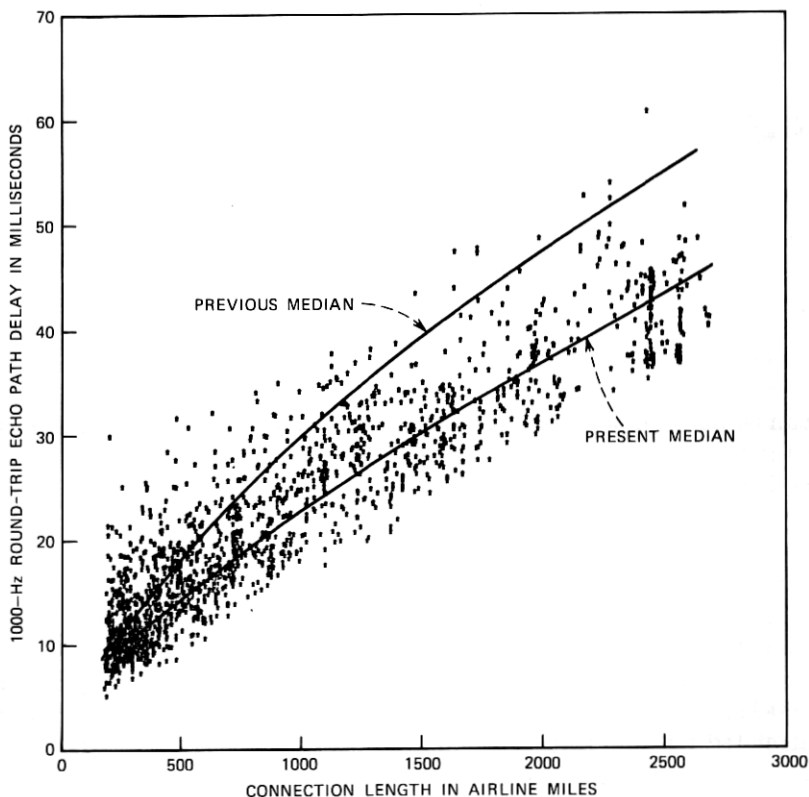

Fig. 16—Comparison of previous and present echo path delays on toll telephone connections.

observations for the echo survey versus the lengths of the connections on which the observations were made. Median 1000-Hz echo path delays are indicated by the two curves superimposed on the scatter diagram. The curve labeled "Previous Median" is based upon the echo path delay information available before this survey,<sup>25</sup> and the curve labeled "Present Median" is based upon the echo path delay data obtained in this survey. To generate the present median curve, the median delay was calculated in nine nonoverlapping, all-inclusive mileage bands. A linear, least-squares, curve-fitting routine was used to fit a quadratic equation to these nine points to obtain the curve. The standard error of this fit is 1.2 ms.

Examination of Fig. 16 shows a reduction in the estimated echo path delay between previous and present median echo path delays of about 11 ms for the longest connections. This improvement in median delay gradually decreases as the connection length gets shorter. For the shortest connections observed, the indicated improvement in median delay is very slight. This trend towards shorter echo path delays may have resulted from the following trends in the telephone plant over recent years: (i) provision of more direct high-usage trunk groups between cities, (ii) increasing use of carrier-type transmission facilities, and (iii) fewer voice-to-carrier frequency conversions in the longer trunks. These trends together produce the cumulative effects of reducing propagation delays attributable to physical transmission media and signal delays attributable to modulation-demodulation equipment.

### **5.3 Echo path loss versus delay**

Echo path loss and delay have been discussed individually. In this section, echo path loss is described in terms of its observed relationship with 1000-Hz echo path delay. Connections are grouped into delay categories to analyze echo path loss. The interval of delay is 5 ms wide for each category. A particular delay category contains all connections having observed 1000-Hz echo path delays that fall within the specified time interval. Table IV lists the average 500- to 2500-Hz echo path losses estimated for each of the delay categories for echo suppressors disabled and enabled.

Results for echo path loss with echo suppressors disabled do not exhibit any trends related to 1000-Hz echo path delay. This is also evident in Fig. 17. Results listed in Table IV for echo path loss with echo suppressors in their normal operating conditions (enabled) show that the estimated average loss increases monotonically with increasing delay once echo suppressors begin to be encountered (around a 1000-Hz echo path delay of 15 ms). The standard deviation also starts changing at that point and continues to get larger until around 35 ms of delay,

**Table IV — Losses versus delay for far-end echo paths on toll telephone connections**

1000-Hz Echo Path Delay (ms)	500- to 2500-Hz Echo Path Loss			
	Echo Suppressors Disabled		Echo Suppressors Enabled	
	Mean (dB)	Std. (dB)	Mean (dB)	Std. (dB)
5-10	24.3 ± 1.2	5.9	24.4 ± 1.2	5.9
10-15	22.6 ± 1.6	5.9	22.6 ± 1.6	5.9
15-20	24.9 ± 2.3	6.2	25.0 ± 2.3	6.2
20-25	25.2 ± 2.4	6.5	29.3 ± 4.0	10.7
25-30	23.5 ± 1.6	6.1	35.3 ± 5.6	14.3
30-35	22.4 ± 1.8	6.8	38.6 ± 5.8	15.4
35-40	22.5 ± 1.6	5.9	48.5 ± 3.3	10.8
40-45	24.7 ± 3.0	7.4	49.3 ± 2.8	11.6
45-50	22.4 ± 0.9	4.2	52.8 ± 4.2	9.0

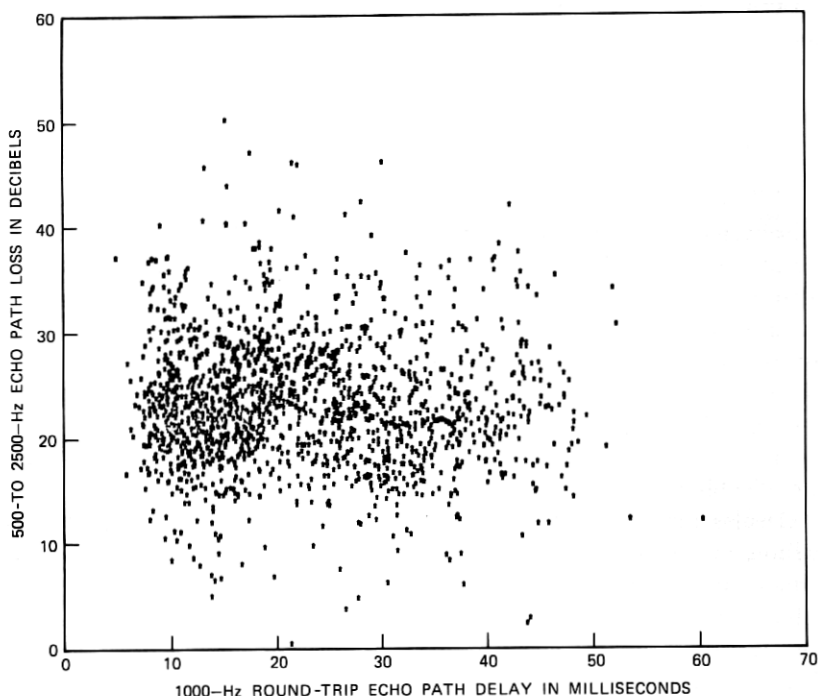

**Fig. 17—Scatter diagram of far-end echo path loss with echo suppressors disabled versus echo path delay on toll telephone connections.**

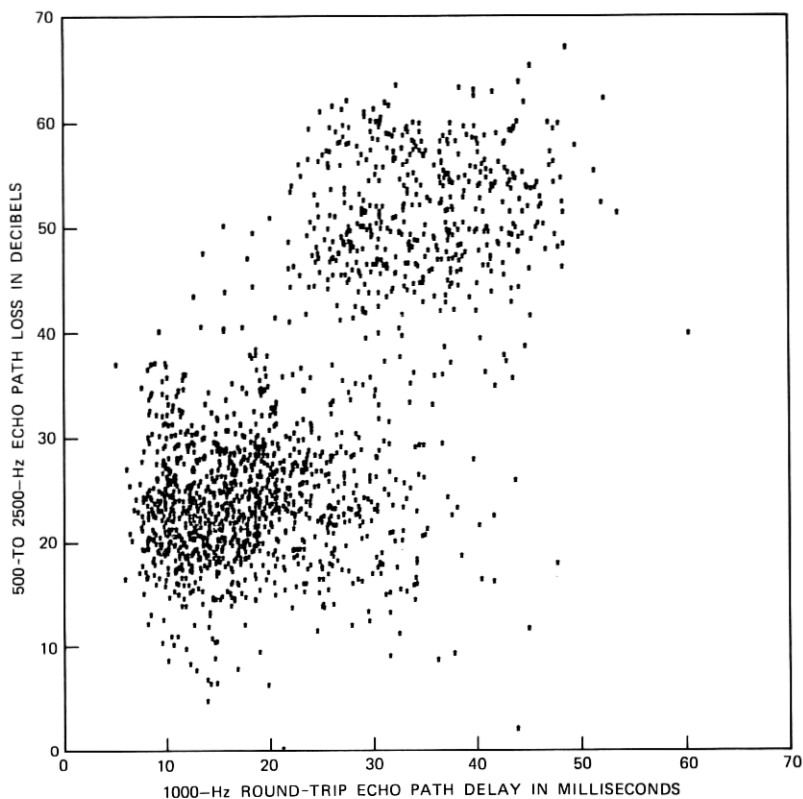

Fig. 18—Scatter diagram of far-end echo path loss with echo suppressors enabled versus echo path delay on toll telephone connections.

when it begins to decrease. This behavior reflects the process of encountering an increasing number of echo suppressors until, at around 35 ms of delay, only a relatively few connections remain that do not contain echo suppressors. This behavior is displayed in the scatter diagram presented as Fig. 18.

#### 5.4 Intermediate echoes

Discussion of the data analysis results has been restricted to far-end echoes in the previous sections. In addition to far-end echoes, distinctly identifiable echoes occurring at intermediate toll switching offices were observed on approximately 28 percent of the connections. On those connections, the mean of the 500- to 2500-Hz echo path loss is  $10.3 \pm 0.7$  dB higher for intermediate echoes than for far-end echoes. The estimated standard deviation of the loss difference is 7.2 dB, and the distribution deviates from normality in the lower tail. Approxi-

mately 5 percent of the intermediate echoes have lower loss than the corresponding far-end echoes on the same connections. In these few cases, the estimated average echo path losses are 30 dB for the far-end echoes and 27 dB for intermediate echoes. On two-thirds of these connections, the two losses are within 3 dB of each other.

The detection of intermediate echoes depended upon the relationship between the magnitude of the intermediate impulse and the peak amplitude of the total impulse response of the test connection. If the peak amplitude of the impulse response was high relative to the amplitude of intermediate echoes on the same connection, it is possible that the intermediates were not detected. Because of this peculiarity in the detection scheme, the estimates above are conservative, i.e., the echo path losses of intermediate echoes are, on the average, *at least* 10.3 dB greater than the echo path losses of far-end echoes.

## VI. CONCLUSION

Acquisition of actual far-end talker echo path loss and echo path delay data on dialed-up long-distance telephone connections is now possible using digital computer techniques. By specifying such echo tests and analyzing the results according to sample survey procedures, echo performance of the continental United States switched telephone network has been characterized.

The echo survey illustrates the power inherent in modern sample survey methods. This is exemplified by the matching of the structure of the sampling plan to the structure of the population under study and by the flexibility in the sample design that allows analysis in subclasses that are not identical to the substrata of the sampling plan.

Results of the survey are being used to model the telephone network and evaluate network changes proposed to improve transmission performance. Significant changes in echo path delay were uncovered, and that information will be valuable in administering the United States DDD network from a transmission viewpoint.

## VII. ACKNOWLEDGMENTS

Many individuals contributed to the echo survey. J. E. Unrue performed early theoretical work and measurement studies. J. R. Rosenberger developed software to record and process the echo data during field tests. Misses K. Haskell and J. Russo and Messrs. R. F. Cook, R. A. Gustafson, J. M. MacMaster, and E. J. Vlacich contributed to processing traffic data from the sampled locations, to processing data gathered during the field tests, and to assembling the data base for characterizing echo performance. Mrs. C. A. Hassol assisted in performing consistency checks and in screening the data. Seventeen

members of Bell Laboratories spent from one to three weeks in the field performing the tests. Finally, we would like to acknowledge the help of many Bell System craftspeople and central office foremen who assisted in the work, and R. Redilla, formerly of the AT&T Headquarters Engineering-Transmission Services Division, who acted as liaison between Bell Laboratories and the operating telephone companies.

## REFERENCES

1. A. B. Clark, "Telephone Transmission over Long Cable Circuits," B.S.T.J., 2, No. 1 (January 1923), pp. 67-94.
2. A. B. Clark and R. C. Mathes, "Echo Suppressors for Long Telephone Circuits," AIEE Trans., 44, April 1925, pp. 481-489.
3. H. R. Huntley, "Transmission Design of Intertoll Telephone Trunks," AIEE Trans., 72, part 1, November 1953, pp. 670-676.
4. *Notes on Distance Dialing*, New York: American Telephone and Telegraph Company, 1968, Section 6, part 3.
5. J. E. Unrue, Jr., "Controlling Echo in the Bell System," Bell Laboratories Record, 47, No. 7 (August 1969), pp. 233-238.
6. C. G. Davis, "An Experimental Pulse Code Modulation System for Short Haul Trunks," B.S.T.J., 41, No. 1 (January 1962), pp. 1-24.
7. K. L. Seastrand and L. L. Sheets, "Digital Transmission Over Analog Microwave Radio Systems," *International Switching Symposium Record*, Cambridge, Massachusetts, June 6-9, 1972, IEEE, New York, 1972.
8. H. E. Vaughan, "An Introduction to No. 4 ESS," *International Switching Symposium Record*, Cambridge, Massachusetts, June 6-9, 1972, IEEE, New York, 1972.
9. J. C. Davenport and D. T. Osgood, unpublished work.
10. P. A. Gresh, "Physical and Transmission Characteristics of Customer Loop Plant," B.S.T.J., 48, No. 10 (December 1969), pp. 3337-3385.
11. I. Dolobowsky, unpublished work.
12. L. R. Pamm, unpublished work.
13. M. H. Hansen, W. N. Hurwitz, and W. G. Madow, *Sample Survey Methods and Theory*, Volumes I and II, New York: John Wiley, 1953.
14. J. R. Rosenberger, unpublished work.
15. B. M. Oliver, J. R. Pierce, and C. E. Shannon, "The Philosophy of PCM," Proc. IRE, 36, No. 11 (November 1948), pp. 1324-1331.
16. W. R. Bennett, unpublished work.
17. Leon Brillouin, *Wave Propagation and Group Velocity*, New York: Academic Press, 1960.
18. W. T. Cochran, et al., "What is the Fast Fourier Transform?" Proc. IEEE, 55, No. 10 (October 1967), pp. 1664-1674.
19. F. P. Duffy and T. W. Thatcher, Jr., "Analog Transmission Performance on the Switched Telecommunications Network," B.S.T.J., 50, No. 4 (April 1971), pp. 1311-1347.
20. W. R. Bennett, M. Schwartz, and S. Stein, *Communication Systems and Techniques*, New York: McGraw-Hill, 1966.
21. A. Papoulis, *The Fourier Integral and Its Applications*, New York: McGraw-Hill, 1962.
22. "Data Communications Using the Switched Telecommunications Network," Technical Reference—PUB 41005, American Telephone and Telegraph Company, New York, 1971, p. 16.
23. F. T. Andrews, Jr. and R. W. Hatch, "National Telephone Network Transmission Planning in the American Telephone and Telegraph Company," IEEE Trans. on Commun. Technology, COM-19, No. 3 (June 1971), pp. 302-314.
24. I. Näsell, C. R. Ellison, and R. Holmstrom, "The Transmission Performance of Bell System Intertoll Trunks," B.S.T.J., 47, No. 8 (October 1968), pp. 1561-1614.
25. T. C. Spang, unpublished work.

