

Cathode Activity Measurement: a Modification of the Dip Test

By D. W. MAURER

(Manuscript received August 17, 1965)

A method of cathode activity measurement which yields fundamental cathode parameters has been developed. Basically, it is a modified dip test and consists of plotting cathode current vs cathode temperature. A simple geometric analysis of the data plot yields data that can be related from one tube to another and to the cathode work function. Thus, experience gained by this simple and rapid technique may be translated from one tube type to another.

This technique can be used to obtain the work function as a function of cathode temperature and a method is suggested for obtaining work function as a function of current density.

I. INTRODUCTION

The activity measurement technique to be described, was developed to fill the need for a standard technique to be used on a rather large diode program. The requirements of an activity measurement for this program which are common to any tube development, may be stated briefly as follows:

(i) The measurement must cause a minimum disturbance to the chemical equilibria existing in the tube, in other words not interrupt the life processes.

(ii) The measurement should be rapid, to permit regular study of a large number of tubes.

(iii) The parameter (s) measured should be related to some fundamental property of the cathode, independent of the tube.

(iv) The technique should not require complicated or specialized electronics which are subject to break down or drift.

A review was made of the currently available techniques. All of them suffer from one or more shortcomings when evaluated by the above

requirements. Child's law plots or perveance measurements are useful but tend to substantially upset the tube equilibrium especially when data are taken at higher cathode loading than the normal operating point of the tube. The higher power invariably leads to deactivation, especially in close spaced diodes. If data above the operating point are taken with short (1 to 2 μ sec.) pulses this problem is eliminated but the process is very time consuming and involves complex electronics. Use of single high-voltage pulses to obtain the current at a fixed point in the Schottky region yields good information so long as equipment is stable and capable of precise calibration. However, it gives no information on uniformity of emission or possible changes in the shape of the Schottky line. The use of short pulses is also difficult without elaborate precautions in the life rack to eliminate stray capacitance and high voltage breakdown. Any of the above techniques are inappropriate in gun-type tubes because of high-voltage breakdown in the tubes and, in the case of traveling-wave tubes, because the beam current is limited by the magnetic field strength. Shot noise measurements are useful and give information on uniformity as well as activity, but require complicated equipment.

Dip testing as first described by Bodmer¹ would satisfy all the requirements previously stated if the data taken could be related to fundamental cathode parameters. That these techniques are effective given good cathodes has been demonstrated. However, for the proposed Bell Laboratories diode program, in which at least some of the cathodes would be of poor activity, and probably of nonuniform emission, this method did not appear suitable. The relationship to basic cathode parameters had also not been shown. Another concurrent and independent piece of work on the dip technique was described by Dominguez, Doolittle and Varadi.² They have explained the shape of the curve and used the data to follow the activation of production tubes.

This paper will describe a modification of the dip technique which is based on a method first used by A. J. Chick³ in connection with the life study of the *Telstar*[®] TWT in 1962. Instead of measuring the usual dip in cathode current in a given time, he substituted a dynamic recording of cathode current and temperature to facilitate the study of the transition region between space charge and temperature limited emission, i.e., the knee. Plotting the knee temperature during life, he found it to be an accurate indication of cathode activity.

The technique has now been further improved and a simple and reliable method will be described to establish the knee even if the transi-

tion is poorly defined. An extensive diode program has been evaluated with this technique and its utility is shown by following tube activity on life. It will also be shown how data taken in this way can be used to determine basic cathode parameters and to obtain measurements of these under conditions not previously obtainable. Examples will also be shown of its use in analyzing the effects of cathode temperature on work function.

II. THE TEST METHOD

In this section the experimental technique and the method of data analysis will be discussed followed by an example of its use. Then the details of several experimental problems will be discussed.

2.1 *The Measurement Technique and Data Analysis*

In the modification of the dip test developed here, an X-Y recorder is used to plot cathode current vs cathode temperature when the heater power is turned off. The experimental apparatus is shown in Fig. 1. The cathode current of the tube on test is recorded on the Y-axis of the X-Y recorder. The temperature, monitored by the infrared pyrometer, is recorded on the X-axis. A typical curve obtained by this technique is shown in Fig. 2. This consists of two regions: on the right is the current vs temperature in the space-charge limited region and on the left is the current vs temperature in the temperature limited region. These two regions are separated by a knee. The roundness of the knee is caused by nonuniformities of emission and the energy distribution of the electrons. The decrease in current with temperature in the space-charge limited region is caused by changes in spacing with cathode temperature and by a movement of the space-

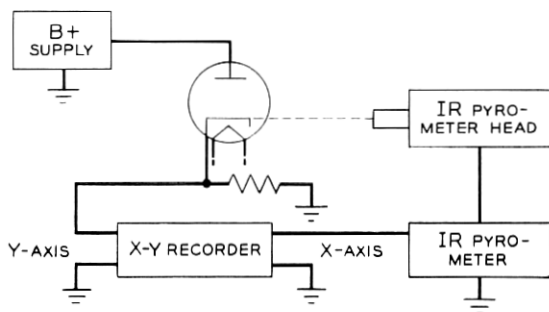

Fig. 1 — Apparatus for IR dip measurement.

charge minimum in front of the cathode towards the cathode as the temperature decreases. The decrease in current in the temperature limited region depends on the work function and is exponential in shape. Experimentally, the upper part of the exponential region can be approximated by a straight line over a short range, as shown in Fig. 2. This is extrapolated up to the initial current and is used to define the knee. The temperature at the knee which is characterized in this way (T_{IR}) corresponds roughly to the temperature at which the tube could be operated and just maintain space charge limited operation at the operating current density. Higher values of T_{IR} derived from this plot imply lower activity and lower values, higher activity.

2.2 A Life Plot

An example of the use of this technique to make a life plot is shown in Fig. 3. This is a plot of data taken after activation on a set of six diodes with experimental cathodes. The curve is the average of data from six diodes. As the end of life approaches, (due in this case to coating depletion), the dip temperature rises to approach the operating temperature, i.e., there is no space-charge limited region at the operating temperature at the failure time.

2.3 Experimental Problems

A difficulty in the use of an infrared pyrometer to monitor temperatures in tubes containing borosilicate glass (Kovar sealing glass)

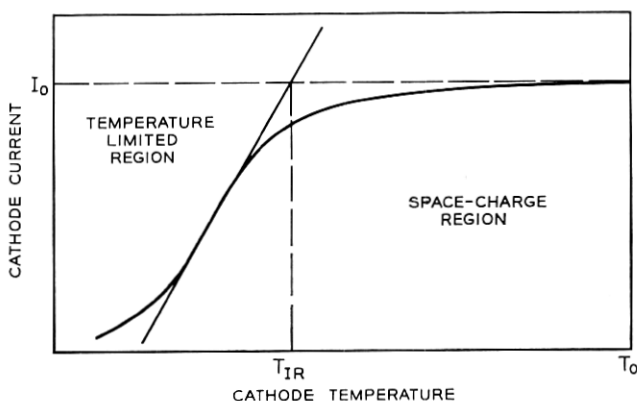

Fig. 2 — Typical data obtained by the IR dip technique.

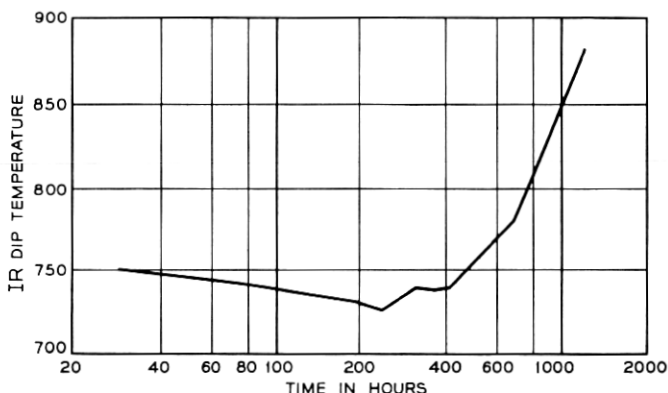

Fig. 3—Life plot of the average of six diodes operating at 850°B.

envelopes is that the glass has a relatively high infrared absorption. Therefore, flaws and variations in thickness of the glass, etc., would have relatively large effects on the temperature measured. To circumvent this problem the temperature of the cathode is adjusted with an optical pyrometer. This technique allows the infrared pyrometer to be calibrated each time the tube is read. That is, glass flaws, variations in the thickness of the glass, etc., enter as correction terms to the emissivity. To demonstrate that these factors would have no effect on the dip temperature, this was measured with the infrared pyrometer in these various situations:

- (i) The infrared pyrometer at various angles to the axis of the tube and at various distances from it.
- (ii) The pyrometer sighted on the cathode base nickel or on the molybdenum cathode heater sleeve.
- (iii) The pyrometer sighted on the image of the cathode nickel in a gold-backed mirror.

In all cases the dip temperatures were identical.

Another difficulty in the use of an infrared pyrometer is that the scale reading, and thus, the X axis of the plot, is not a linear function of temperature and a conversion chart must be used to obtain the temperature. Since most of our diodes are operated at one of three temperatures we have alleviated this problem by making a plexiglass ruler which has the three temperature scales for the X axis corresponding to each tube temperature. In this way, it is a simple process to measure the knee temperature directly from the plots.

Thermocouples may also be used to measure cathode temperature; however, these are often unreliable over long periods of time. In some cases thermocouples are not practical and the cathode cannot be directly viewed with a pyrometer. This is usually the case for a traveling-wave tube in its magnetic circuit. In this case, we have obtained a temperature vs time curve for a dip outside the circuits; then a current vs time plot was taken in the circuit. The current-time curve is analyzed in the same manner as current-temperature curves to give a knee time. The temperature can then be obtained from the temperature-time calibration. This calibration must be checked periodically due to changes in cathode support welds, heater resistance, etc.

III. OTHER APPLICATIONS OF THE TEST METHOD

In this section the analysis of the data will be extended to show how the information obtained from the dip plots is related to the work function φ . First, the method of obtaining φ from the test data will be described. Then the description of the method of obtaining it as a function of temperature independently of the A constant will be given. Finally, a method will be proposed for the determination of work function as a function of current density.

3.1 Measurement of Work Function

In the temperature limited region shown in Fig. 2, the current follows the well-known Richardson equation modified due to the Schottky effect caused by the field on the cathode.⁴ The equation for the combination of the two effects is easily obtained by substitution:

$$\ln \frac{J}{T^2} = \ln A + \left(0.44(GV)^{\frac{1}{2}} - \frac{\epsilon\varphi}{k} \right) \frac{1}{T},$$

where

- J = current density,
- T = absolute temperature,
- A = the Richardson Constant,
- G = geometry factor,
- V = voltage,
- ϵ = electronic charge,
- k = Boltzman constant,
- φ = work function.

According to this equation, in the temperature limited region at constant voltage, if the $\log J/T^2$ is plotted against $1/T$, a line should be obtained whose slope is a combination of the work function and the geometric factor. A calculation shows that the geometric term should be negligible for planar diodes with respect to the work function term at the voltages used.* Under these conditions this equation reduces to the Richardson equation. Originally, a series of dips were taken at various tube voltages and the knee temperatures (T_{IR} on Fig. 2) were used to make a Richardson plot. These plots were always straight lines. This was taken as confirmation of the utility of the knee temperature as a significant measure of cathode activity.

Data have also been taken from a single dip curve below the knee and fed into a computer to determine a least squares fit, calculate the work function and plot the data. An example is shown in Fig. 4. There is a very good fit to a straight line. The slope corresponds to a work function of 1.2 eV.

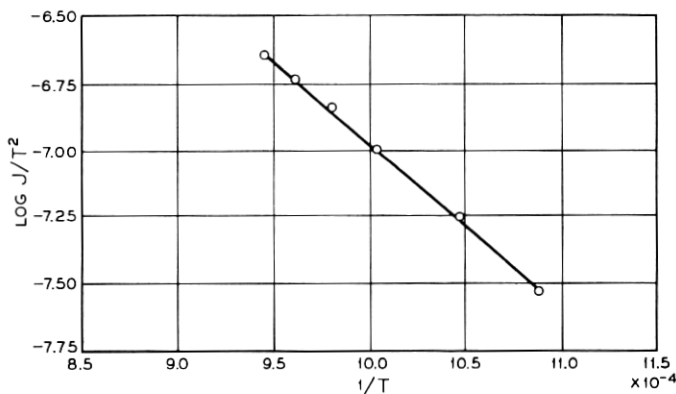

Fig. 4 — Richardson plot for tube 370.

3.2 Work Function as a Function of Temperature

As a basis for discussion in this section and the following one (Section 3.3) several points from the generally accepted hypothesis of cathode operation are pertinent:

- (i) The cathode is a semiconductor with mobile donors which mi-

* The term GV is the field at the cathode. For parallel plane geometry, $G = 1/D$ where D is the separation distance. Other geometric configurations may be calculated appropriately, see Ref. 4, p. 30.

grate under the influence of fields. The time constant for donor redistribution is of the order of milliseconds.⁵

(ii) The lifetime of donors in the coating is much longer than their transit time across the coating. Usually the lifetimes are of the order of hours.^{5, 6, 7}

(iii) The work function of the cathode is a slowly varying function of donor concentration at the surface down to a critical value, whereupon it rises rapidly with further decrease in concentration.

The fact that donors redistribute themselves within milliseconds under the influence of fields means that the work function measured by the dip technique will not contain the effect of current density. Therefore, measurements should be made at low current densities where these effects are small; otherwise an average of the donor distribution will be obtained and the effect will be difficult to analyze. On the other hand, the fact that donor loss is quite slow, means that the total donor concentration (not the concentration gradient) within the cathode will be essentially "frozen in" as the cathode cools and the effect measured will be that of a cathode *as it exists at the starting temperature*. Thus, with this technique, we can measure the work function and the A constant *independently* at a given cathode temperature. This point is important. The usual technique of getting the temperature dependence of the work function is to measure J and T , insert them into the Richardson equation and solve for ϕ assuming $A = 120$. This assumption is not a good one for oxide cathodes. The A constant contains a term which is the "effective" emitter area, i.e., that area which is actually emitting electrons. It has been widely demonstrated in the literature that oxide cathodes are composed of an aggregate of small areas of high and low work function. Furthermore, measured A values for oxide cathodes determined by the conventional plotting techniques mentioned above vary widely (10^{-3} to 2.8×10^4).⁸

The advantage of this technique in measuring work function is demonstrated from data taken on two similar diodes. The work function of one was measured by the usual technique of taking Schottky data at various cathode temperatures. A plot of these data is shown in Fig. 5. Data from these curves were then replotted according to the Richardson equation to give the plot shown in Fig. 6. This plot has a straight line section with a slope which corresponds to a work function of the order of 1.5 eV. The points deviating from this line at the higher temperatures are characteristic of what is observed on

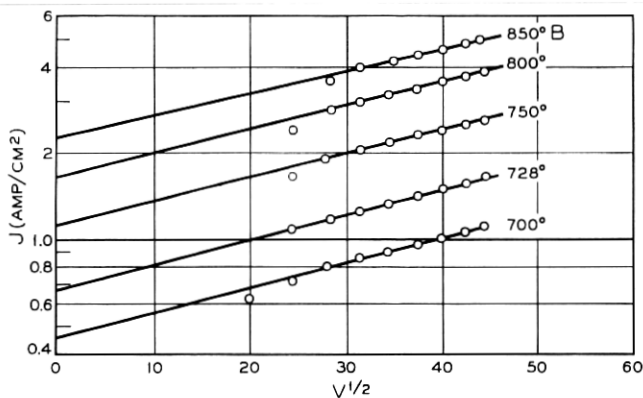

Fig. 5 — Schottky plot of tube 246.

many cathodes and represent a changing cathode system in these regions which results in an increasing work function and probably a changing A value. The most likely explanation is that the donor depletion at the higher temperature increases faster than the donor production rate. This results in cathodes of higher work function at the higher temperature. This was confirmed on another tube where the work function was measured by the dip technique described above. The work function measured at an initial cathode temperature of 750° brightness was 1.5 eV in good agreement with the results of the Schottky plot. However, the work function measured at 850° brightness was 1.7 eV.

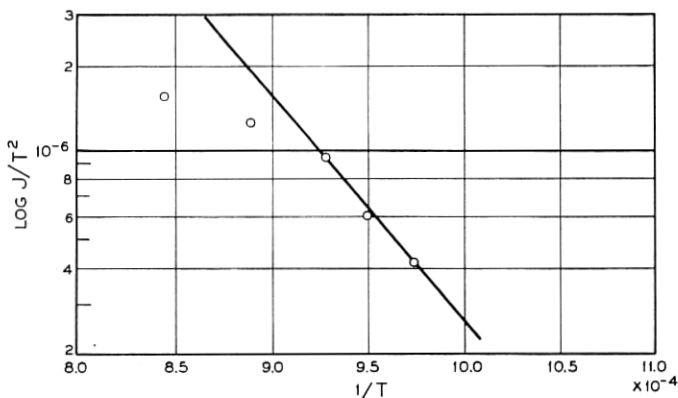
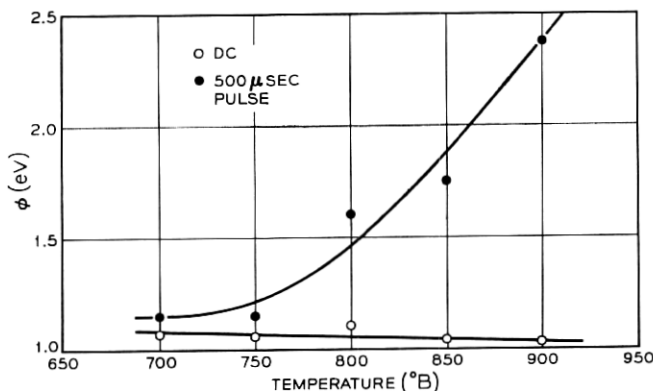
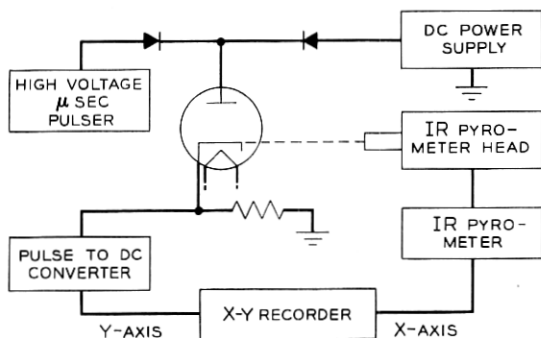

Fig. 6 — Richardson plot of data from Fig. 5.

Fig. 7 — ϕ (T) for an experimental cathode.

This technique has been used to demonstrate electrolytic activation in an experimental cathode which is described elsewhere.⁹ In this case the work function was measured for various cathode temperatures using both dc and 500 μ sec pulses. The results are shown in Fig. 7. Notice that the values obtained by using dc follow what might be considered the normally expected pattern and are relatively constant. The pulse values, however, are constant only up to about 750°B where they increase rapidly with further increase in temperature. The explanation for the pulse results is the same as for the plots previously presented: The donor loss increases faster than donor production. The dc values remain constant because electrolysis is contributing to the donor production, and therefore, ϕ remains low in

Fig. 8 — Apparatus for measurement of ϕ vs J .

value. It may be expected that the dc values would increase if the temperature were taken higher.

The utility of this technique in measuring work function in an operating temperature range where the work function of the cathode is changing as a function of cathode operating temperature has been demonstrated. The possibility of measuring work function independently of A at a set temperature in a region where ϕ is changing as a function of temperature was not recognized before. Thus, it is a new tool for the investigation of the mechanism and operation of cathodes in this region.

3.3 Proposed Measurement of Work Function as a function of Current Density

If one wanted to observe the variation in work function with current density, the following technique could be used. The apparatus is shown in Fig. 8. Here, microsecond pulses are to be superimposed on a dc operating level. The pulse current is to be used to make dip measurements. In this way the temperature limited region well above the operating current density can be monitored to define the work function while the dc operating current density is still in the space-charge limited region. By this means, the point at which the work function begins to rise rapidly with current density, i.e., the dc current density at which donor depletion at the surface becomes appreciable, can be determined. This limiting current density is a measure of the minimum donor concentration required in the surface of the cathode under given dc conditions.

IV. CONCLUSIONS

The modified dip test described here yields data which can be related to a fundamental cathode parameter, namely the work function. This permits quantitative studies of cathode activity throughout life. The technique can further be used to determine information about the concentration of the donors in the cathode. The method described is of general practical utility; the data can be obtained rapidly and be directly compared from one tube type to another.

REFERENCES

1. Bodmer, M. G., Dip Testing, A New Method for Measuring Cathode Activity, IRE Transactions on Electron Devices, *ED-5*, #1, 1958, pp. 43-44; Bodmer, M. G., et al, Satellite Traveling-Wave Tube, B.S.T.J., *42*, No. 4, July 1963, pp. 1740-1743.

2. Dominguez, R., Doolittle, H. D., and Varadi, P. F., Oxide Cathode Evaluation by Dip Test Method, Rep. 24th Annual Conf. Phys. Elec., 1964, pp. 27-35.
3. Chick, A. J., private communication
4. Cf. Nottingham, W. B., Thermionic Emission, *Handbuch der Physik*, 21, 1956, pp. 8 and 32.
5. Krusemeyer, H. J., and Pursley, M. V., Donor Concentration Changes in Oxide-Coated Cathodes Resulting from Changes in Electric Field, *J. Appl. Phys.*, 27, 1956, pp. 1537-1545.
6. Kawamura, H., Shinohara, A., and Takahashi, J., On the Active Centers of the Oxide-Coated Cathode, *J. Phys. Soc. Japan*, 3, 1948, pp. 301-304.
7. Frost, H. B., Gas Content and Cathode Emission Changes in Cut-off Electron Tubes, *Supplemento al Nuovo Cimento, Serie I*, 1, 1963, pp. 780-790.
8. Herrmann, G., and Wagener, S., *The Oxide Coated Cathode*, 2, Chapman & Hall Ltd., London (1951), p. 181.
9. Maurer, D. W. and Pleass, C. M., The CPC: A Medium Current Density, High Reliability Cathode, *B.S.T.J.*, this issue, pp. 2375-2404.