

# A General Description of the *Telstar* Spacecraft

By R. H. SHENNUM and P. T. HAURY

(Manuscript received February 6, 1963)

*The Telstar spacecraft design is discussed with emphasis on the electronics system. The description includes early planning, starting with frequency allocation considerations, and carries the program through electrical and mechanical design, construction and evaluation of the electronics system. The content is aimed at a broad introduction, depending on companion papers for many details of the spacecraft design.*

## I. INTRODUCTION

A description of the Telstar spacecraft presented in this paper is developed chronologically so that the reader may understand how each of the decisions influenced the design and construction which followed. Foremost in practical considerations affecting the satellite design was the selection of the Delta vehicle to launch the spacecraft.

## II. BACKGROUND

Another paper of the series<sup>1</sup> outlines the needs for an orbit which would reach the vicinity of 3000 nautical miles apogee with a perigee of at least 500 nautical miles. The capability of the Delta vehicle to put a satellite into such an orbit, with the restriction of a launch from the Atlantic Missile Range and the desired inclination of the orbit plane to the equator of  $45^\circ$ , limited the permissible weight of the spacecraft to the order of 180 pounds. This weight limit was a severe restriction to incorporation of many ideas which were proposed early in the development. The second characteristic of the Delta which was influential in the Telstar spacecraft design was the existence of only two fairings and the decision not to undertake the development of a new one. The larger of the two, which had been tested repeatedly in satellite launchings and was large enough for our purposes, was selected as one which would be suitable for the spacecraft, as described in Section IX. The third aspect

of the Delta which was influential in planning the Telstar system was the need for spin stabilization of the third stage, which is a solid fuel motor without radio guidance. Typical spin rates of 200 revolutions per minute are used for this third stage and, while it would have been possible to despin the satellite after injection into orbit, it was judged desirable to utilize the spin for stabilization. In this way, the weight which would otherwise have been associated with a despin mechanism was saved. The detailed development of the structure of the frame, the shape of the spacecraft, and other mechanical aspects are treated in another paper in this issue.<sup>2</sup>

### III. FREQUENCY ALLOCATION

Project Telstar was planned from the first as being primarily a communications experiment. However, other scientific experiments were also a very important part of the early planning. The selection of the frequency assignments used in Project Telstar is mentioned in Ref. 1. As discussed in that paper, some early thinking was based upon the assumption that new frequencies exclusively for the use of satellite communications could be assigned, and that interferences into and out of the ground receiver and transmitter, respectively, would be eliminated. It became apparent as the project developed, however, that such frequencies for exclusive use were not to be available for the Telstar experiment, so plans were developed for joint use of the 4-gc and 6-gc common-carrier bands with existing land-based microwave equipment. Both of these bands are in the broad spectral region where galactic noise is almost negligible compared to signals expected to be received at the ground station, and where atmospheric absorption is not a serious matter. The 4-gc band is, however, in the more favorable region and was chosen for the spacecraft microwave transmitter. The actual frequencies to be used were so chosen that they coordinated in the 4-gc region with existing TD-2 system assignments in this country and abroad, and in the 6-gc band with the TH system assignments, which are the same throughout the world. As seen in Fig. 1, the 16 satellite channels either coincide with existing common-carrier frequencies or fall approximately midway between bands. Concurrent work by H. E. Curtis was reported earlier.<sup>3</sup> His proposed frequency allocation plan, though very similar in most respects, resulted in frequencies slightly different from those actually used in the Telstar plan.

Although the Telstar repeater was conceived from the beginning as a single broadband amplifier, it was considered necessary that the frequencies used would be consistent with those which would later be

assigned to multichannel communications satellite systems. Allocations were studied and based on both six and eight channels allocated in each of the 500-mc\* bands at 4 and 6 gc, respectively. The final choice of frequencies for the Telstar plan was based on an assignment which permits the eventual existence of eight broadband channels. In addition to the selection of frequencies for the broadband amplifier, a microwave beacon was an important part of the planning. Fig. 1 is a diagram giving the allocations both in the U. S. and in Europe in the 4- and 6-gc common-carrier bands and showing the location of the eight up and eight

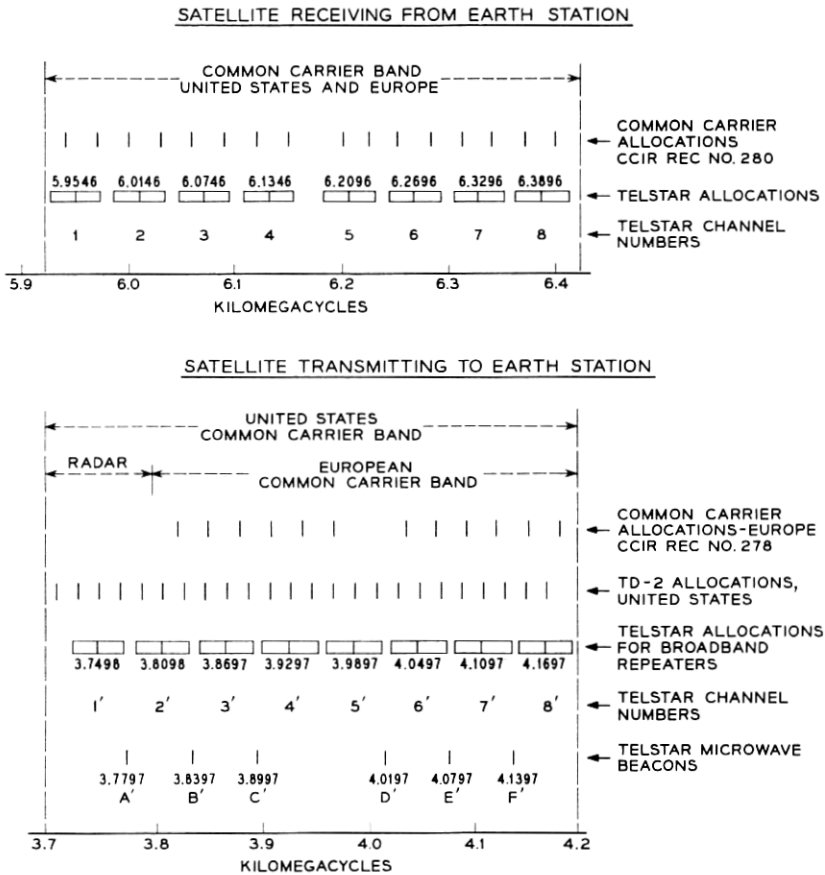

Fig. 1 — Frequency allocations

\* Abroad, the 4-kmc band is narrower than the U. S. 500-mc assignment, as seen in Fig. 1.

down channels which are recommended for satellite use, as well as the frequencies for the associated microwave beacon tones. Channels 8 and 8' with beacon E' were used for Project Telstar.

To minimize the amount of electronic equipment in the spacecraft, the microwave beacon was obtained from the pump frequency of the up-conversion process. Consequently, the separation between the microwave beacon and the center of the broadband channel determined the midfrequency of the intermediate-frequency amplifier. The state of the art of transistor amplifiers for intermediate frequency use with proposed bandwidth of 50 mc dictated a center frequency above that which typically had been used for land-based microwave equipment. Preliminary designs of IF amplifiers which existed at the time of the beginning Telstar program made possible a center frequency of as high as 100 mc. The last constraint which was introduced into the calculations, and the one which in the final analysis proved to be the most limiting, was the requirement that the down conversion and the subsequent up conversion be accomplished by use of a pair of frequencies obtained from a coherent microwave carrier supply, with a single crystal-controlled oscillator producing both local oscillator signals. As will be noted in the discussion to follow, this last-stated objective was not to be attained, and an alternate method was adopted.

Fig. 2 shows a block diagram of the microwave carrier supply originally planned, with levels and frequencies sufficiently accurate for engineering purposes satisfying the previously stated requirements. This basic block diagram is readily expandable to obtain all necessary frequencies for an 8-channel system from a single crystal oscillator. Calculations by R. W. Hatch in unpublished work show that the noise associated with a non-

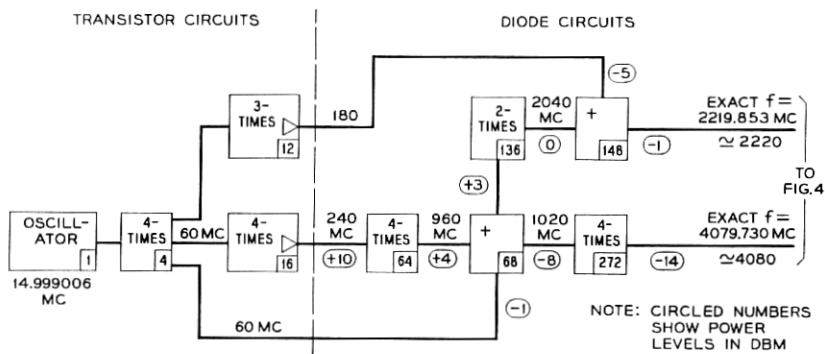

Fig. 2 — Single oscillator microwave carrier supply originally proposed.

coherent microwave carrier supply is not a major contributor to the over-all system noise. Despite the fact that it would have been desirable to eliminate this small noise contribution, the schedule of the Telstar program did not permit carrying to completion the circuitry indicated in Fig. 2. The decision was made about midway through the program (Aug., 1961) to implement the microwave carrier supply along the lines shown in Fig. 3, where two separate crystals are used. The resulting frequencies are the same as those in Fig. 2 to the first six significant figures. Better coordination with the existing land-based microwave systems could have been obtained by use of the two-oscillator approach. However, other parts of the program were so far advanced that a frequency change at that time was not possible.

#### IV. THE ELECTRICAL REQUIREMENTS OF THE MICROWAVE RECEIVER

The over-all signal-to-noise performance is summarized in a preceding paper.<sup>1</sup> Parts of this will be repeated and expanded in this discussion in order that an over-all description of the satellite proper may be contained within this paper. Data given here will supply the details necessary for the understanding of the block diagram of the communications repeater shown in Fig. 4. The nominal planned received signal for mid-range operation at the input to the converter is  $-60$  dbm. There is an allocation of loss of 2 db between this point and the antenna, so that the nominal signal received into the antenna is  $-58$  dbm. The IF amplifier operates with a midfrequency of approximately 90 mc and has a bandwidth requirement at the 1-db points of  $\pm 25$  mc about this midfrequency. The automatic gain control was specified to operate over a signal range of approximately  $+5$  to  $-12$  db. The traveling-wave tube

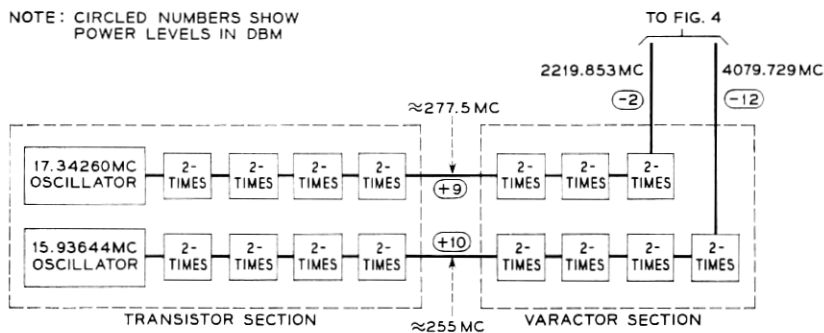

Fig. 3 — Final microwave carrier supply.

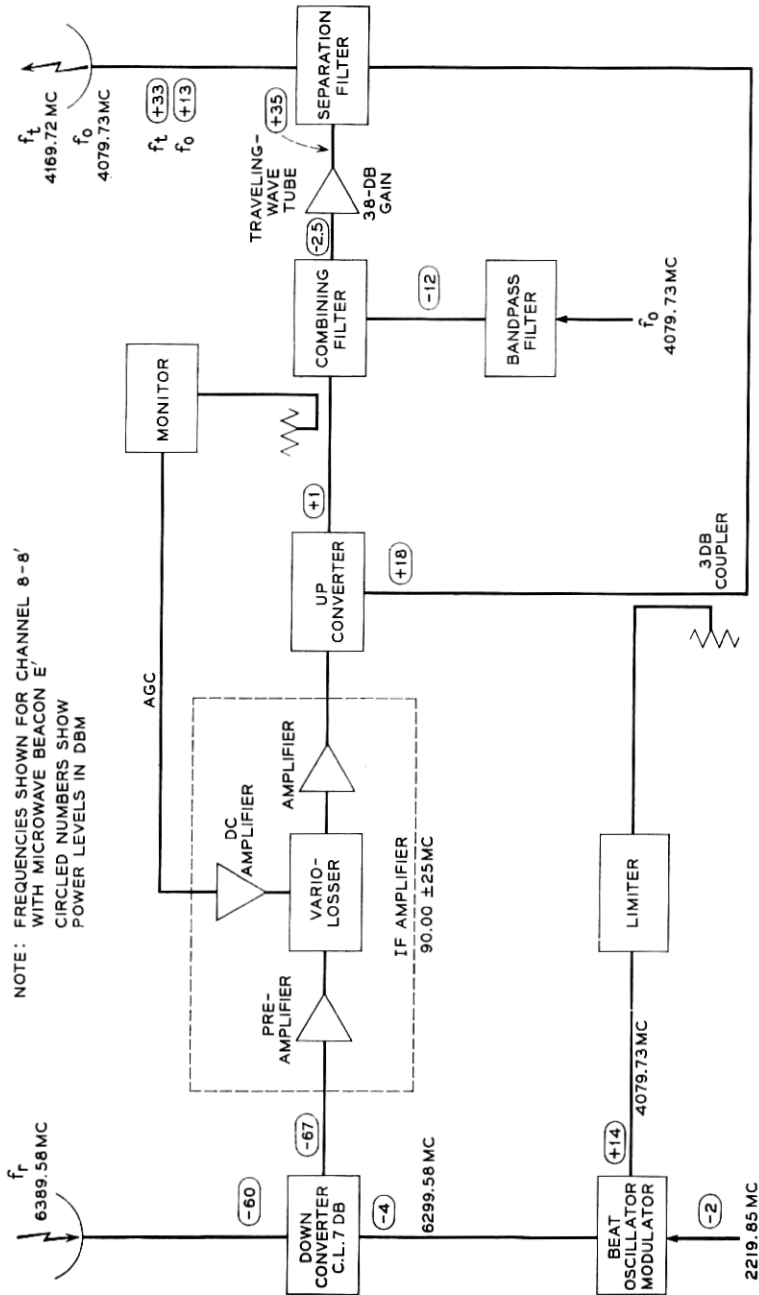

Fig. 4 — Telstar satellite amplifier simplified block diagram.

(TWT), the only electron tube in the Telstar satellite, amplifies two signals simultaneously. One, the main broadband signal with approximately 50 mc potential bandwidth, is required at an operating point in the tube at which the gain is 37.5 db and the power output is +35 dbm. The second signal at the output of the tube is 13 db lower than this main signal (i.e., +22 dbm), and under the condition of simultaneous existence of the two signals, separated in level by 13 db, the gain for the low-level signal is 35 db. The circuitry thus operates in a reflex mode such that the 4080-mc signal, which is one of the outputs of the microwave carrier supply, is combined with the main signal in the combining filter, amplified through the traveling-wave tube, and in the separation filter is largely transmitted back into the microwave repeater for use as the pump frequency in the up-conversion process. Part of the 4080-mc signal is also combined in the beat-oscillator modulator with a second output from the microwave carrier supply to produce the beat oscillator frequency for the down-conversion process. As will be discussed later, a small part of this 4080-mc signal at the output of the TWT is directed by the separation filter directly to the microwave transmitting antenna, where it is radiated to the earth station and used by the precision tracker and system autotrack for acquisition and tracking of the satellite. The radiated signal strength of the 4080-mc beacon at the output of transmitting antenna was required to be at a minimum power level of +13 dbm. The circuit design of the microwave repeater with its TWT in this dual-amplification mode with two signals widely separated in level was based on analytical predictions and early experimental work which was done by P. R. Wickliffe and reported in unpublished work. The experimental work was performed at 6 gc with traveling-wave tubes which were of sufficiently similar structure to the tube proposed for use in the Telstar repeater circuit that it was felt reasonable to extrapolate the results to the 4-gc operation.

#### V. THE ELECTRICAL DESIGN OF THE COMMUNICATIONS REPEATER

The operating levels of the communications repeater are given in the block diagram of Fig. 4. The design requirements have been discussed in the preceding section. This section describes briefly the realization of the system satisfying these requirements. The down-conversion system, consisting of down converter and its associated filters and beat oscillator signal from the microwave carrier supply, is in broad principle similar to those used in earlier land-based microwave systems.<sup>4</sup> The physical structure is, however, quite different and is based on operation of the

received signal and beat oscillator signal in orthogonal modes in a round waveguide. This is described in detail in another paper in this issue.<sup>5</sup> The noise figure and conversion loss, 12.5 db and 7 db respectively, resulting from this configuration, are both within the ranges which have been obtained at this frequency and bandwidth by earlier experimenters. However, the level of the beat oscillator signal ( $-4.0$  dbm) to the down converter is substantially below that normally used. This low oscillator signal level was, of course, used because of the necessity to conserve power and to operate at the lowest practical level; however, small changes in power level are not troublesome with the regulation schemes provided. Similar statements concerning power levels can be made about almost every other block within the communications repeater.

The IF amplifier and associated automatic gain control will be described in considerable detail later in this issue.<sup>5</sup> The IF amplifier has a common-emitter doublet input stage working into a resistive load. The bandwidth of the IF amplifier is 50 mc, while the noise figure is 4.5 db. The 90-mc signal is amplified using broad-band common-emitter transistors with local shunt feedback. The amplifier is so designed that, should one of these transistors open circuit, the feedback network would operate to continue to provide a fairly flat transmission path without excessive loss.

The last two stages of the amplifier are common-base circuits. These circuits provide linear amplification at output power levels up to  $+6$  dbm. A 20-db return loss is maintained at the output over the 50-mc frequency band. The maximum gain of the IF amplifier is 87 db. The gain of the amplifier is controlled using two similar resistive T-network diode variolossers. Each gives approximately 15 db of control range, more than satisfying the original requirement for a 17-db range.

The AGC variolossers are driven by a dc amplifier requiring four transistors. These are arranged in a differential input stage followed by two common-emitter stages. The sensing for the AGC is a measure of the signal output of the up converter, in contrast to the more usual method of monitoring the output of the IF amplifier. Since the up converter operates with relatively low pump power, its output is subject to some variations caused by temperature changes and aging. The action of the AGC compensates for these variations and ensures constant input to the TWT.

The up-converter is a balanced diode modulator in which the 90-mc signal is shifted to a frequency band centered at 4170 mc. It was designed for temperature stability and minimum susceptibility to fluctuations in



beat oscillator power. Consequently, the conversion gain of the device is low — only about 2 db.

The 4170-mc signal passes through a filter-monitor combination. The monitor is part of the AGC circuit, which ensures that the level of the signal fed to the TWT is constant. The monitor contains two separate diodes, mounted in the waveguide in a configuration designed to minimize directivity. The time and temperature stability of the monitor is better than  $\pm 0.25$  db.

The TWT amplifier is unusual for its high efficiency. A single-reversal permanent magnet is used for beam focusing in place of the customary straight field magnet such as that used in TH radio.<sup>6</sup> In addition to saving weight, this arrangement gives a substantial reduction in the associated magnetic dipole of the spacecraft, which must be neutralized by the addition of small magnets on the surface of the satellite to limit interaction with the earth's magnetic field. A net magnetic moment for the satellite of 1 ampere-turn meter squared was attained.

Some of the design parameters of the traveling-wave tube are given in Table I. It is of interest to note that the voltages and currents have been chosen to give maximum over-all efficiency, including the heater power, rather than maximum electronic efficiency. In the present design, lowering the collector voltage below the helix voltage increases the efficiency appreciably. The TWT is operated in the nearly linear region, where the output power is about 1.25 db below the saturation output power. This is done both to assure stability of the over-all circuit and to reduce intermodulation. The anode voltage is kept above the helix voltage to provide ion pumping. Further details describing the tube have been included in another article in this issue.<sup>6</sup>

The final microwave carrier supply provides local signals at approximately 4080 mc and 2220 mc. These frequencies are derived from crystal oscillators which drive transistors and varactor-multiplier chains as shown in Fig. 3. The two paths are similar except for the output stages, so only the one with the larger multiplication is discussed. The

TABLE I

Helix voltage	1500 volts
Anode voltage	1750 volts
Collector voltage	750 volts
Cathode current	17.5 milliamperes
Output power (saturated)	4.5 watts
Heater power	1.5 watts
Collector power	13 watts
Gain (saturated)	36.5 decibels

nominal 4080-mc (microwave-beacon frequency) path starts with a solid-state Pierce oscillator at about 15.9 megacycles. To ensure maximum short-term stability, the oscillator is operated at a high level. Since the crystal is driven hard, it is necessary to have crystals that are free from unwanted resonances at this operation level over the whole temperature range likely to be encountered. The long-term stability is determined mainly by the temperature characteristic of the crystals. All units manufactured met the specified limit of five parts per million, and in the Telstar satellite the microwave beacon has a stability of better than one part per million from 0 to 60°C. It is expected that the effect of aging will be of the order of one part per million per year.

The output of the oscillator is fed to a doubler stage and then the signal is alternately passed through transistor-doubler stages and amplifier stages until a frequency of 255 mc is reached. Temperature compensation is provided to the last four stages, keeping the output constant to 0.2 db over a range from -10° to +50°C.

The 255-mc signal from the last transistor doubler is passed to a three-stage varactor multiplier using conventional lumped circuits. The output from these circuits is fed into a coaxial doubler, which connects the 4080-mc signal through a transducer into the combining network that feeds the traveling-wave tube. The units performed well and the entire harmonic-generator system showed less than 1.5 db variation in level over the temperature range 0 to 50°C.

## VI. TELEMETRY AND COMMAND

The need for a telemetry system arises from three types of required measurements:

- (a) communications experiment data such as transmitted and received signal strengths, and states of several relays;
- (b) general "housekeeping" data such as temperatures, pressure in canister, currents and voltages of subsystems;
- (c) radiation experiment measurements related both to integrated damage to solar cells and transistors and to counts of electrons and protons in several energy bands.

To simplify the telemetry in a way which is consistent with the design of the entire electronics system, it was decided to use a one-per-minute frame rate, which is very slow compared to normal industry standards. A tabulation of the necessary measurements in the three categories previously listed indicated that 118 channels would provide the required

data. The final channel assignment is described in some detail in another paper of this series.<sup>7</sup> The channels are approximately equally divided into the three categories which were listed earlier. Because of the needs of the radiation experiment for high accuracy, it was decided to use a PCM system with 7 bits, giving slightly better than 1 per cent basic coding accuracy and an over-all accuracy including the effect of gating of approximately 1 per cent. While most of the channels are sampled in analog fashion and converted to digital form, direct digital counts are used in much of the radiation particle counting, in order to increase the accuracy of the measurements. This is described in detail by Ref. 8 of this issue. The modulation scheme utilized to impress the telemetry information on the 136.05-mc VHF beacon (the power output of which is +23 dbm) involves two stages of modulation. The PCM signal is first changed to a frequency-shift form of modulation with frequencies of 3225 and 2775 cps representing the binary 1 and 0, respectively. This is then amplitude-modulated onto the 136.05-mc carrier. This form of modulation was utilized to keep the major sidebands far enough removed from the 136.05-mc carrier that it would be possible to utilize the carrier for tracking purposes in the presence of the telemetry signal. The percentage modulation was limited to 50 per cent to limit the sideband amplitudes and hence to ease tracking problems.

The need for a command system was established when the decision was made to operate the TWT only part time and to depend upon energy stored in a nickel-cadmium battery for the operation of the tube. The solar plant, when new, delivered slightly under 15 watts. This is expected to fall to two-thirds this value in a two-year period. With all the subsystems in the satellite operating simultaneously, the required power is more than twice that which is available from the new, undamaged solar plant. The command system provides sequential turn-on and turn-off of three voltages for the traveling-wave tube. The sequencing is controlled from the ground in order to permit the simplest possible satellite electronics system. In addition to the five commands which are utilized for TWT operation, commands are provided to turn the telemetry off and on and to switch or reverse the current in an orientation loop provided to correct spin-axis orientation, should this be required. Commands are also provided for test purposes to evaluate the operation of the two separate redundant command systems. Finally, it is possible to control a battery-cutoff relay which is provided to protect the nickel-cadmium cells from excessive discharge.

The command code structure was chosen to be consistent with that in use by the National Aeronautics and Space Administration Minitrack

network, (in order that the far-flung Minitrack stations would have command capability). The 15 command signals are at a frequency of approximately 123 mc and are modulated in a pulse-duration manner which is described in detail in Ref. 8. The block diagram, Fig. 5, shows the association of the command and telemetry and beacon systems, coupled through a diplexer to a common VHF antenna.

## VII. ANTENNAS

Separate microwave antennas (pictured in Fig. 6) are used for the 6390-mc reception and the 4170-mc retransmission of the broadband microwave signal. The receiving antenna, the upper of the two equatorial units, consists of 72 boxes or ports which are coupled together with matched amplitude and phase so that the pattern of the antenna around the equatorial region of the satellite varies about 2 db peak-to-peak, as shown in Fig. 7(a). The antenna has reasonably uniform properties for an angle of  $\pm 60^\circ$  about the equator, leaving at either pole a cone with

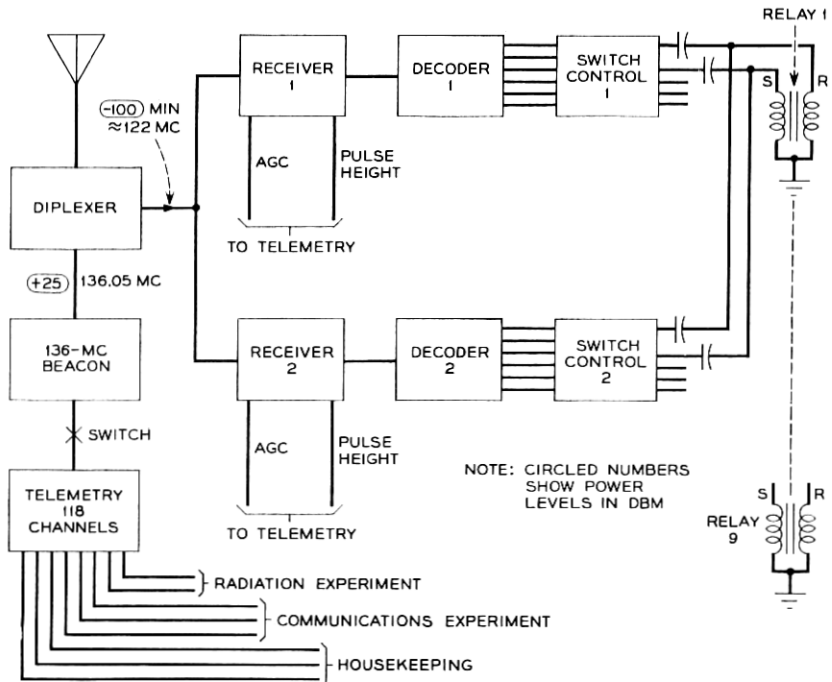

Fig. 5 — Telstar command and telemetry.

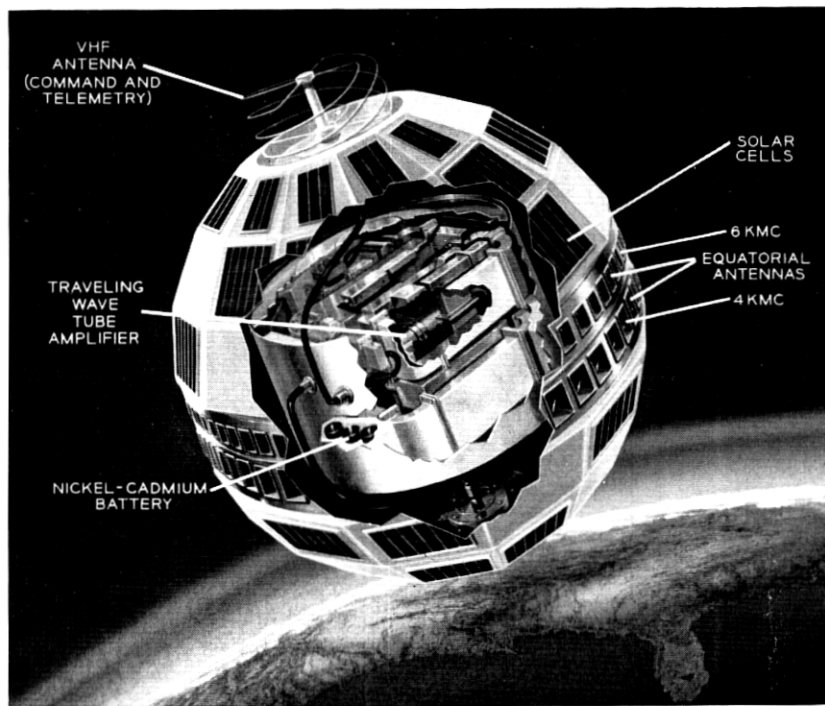

Fig. 6 — Spacecraft, showing antennas.

a half angle of  $30^\circ$  containing deep nulls. The details of the antenna are described by Ref. 9. The goal of the design was to produce a circularly polarizing antenna having a near isotropic pattern.

The microwave transmitting antenna is very similar to the one used for reception. It consists of 48 apertures, again equalized for amplitude and phase, and has radiation properties similar to those just described for the receiving antenna. The transmission loss between the receiving antenna and the down converter is approximately 2 db, while the loss between the output of the traveling-wave tube and the radiating apertures of the transmitting antenna is about 1.5 db. Contributing to these losses are the coaxial cables which couple the electronics canister to the radial power splitter and the cables which connect the outputs of the power splitters as antenna feeds to the hybrids. The transmitting and receiving power splitters are respectively 6-way and 9-way, which couple to as many hybrids. Each hybrid further subdivides by a factor of eight to couple to the individual ports of the respective antennas.

The VHF antenna is used both for transmission of the 136.05-mc

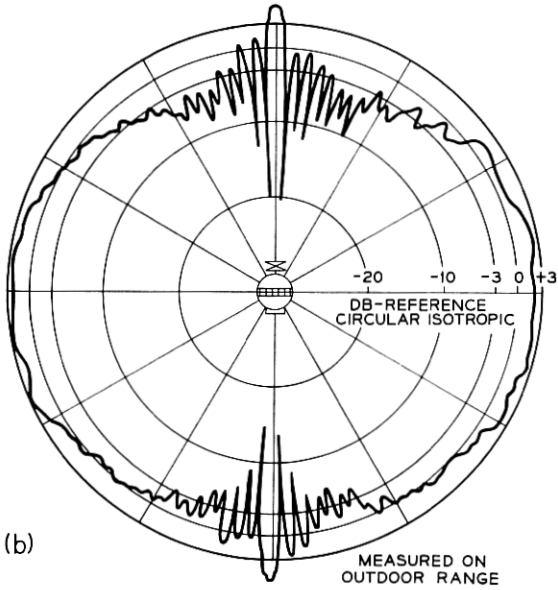
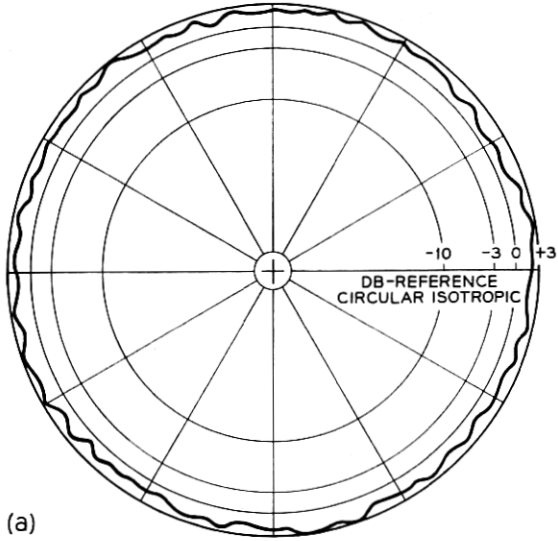

Fig. 7 — Antenna patterns at 6390 mc: (a) equatorial aspect; (b) polar aspect.

beacon signal, which is amplitude modulated with telemetry information upon command, and the reception of command signals at approximately 123 mc. The antenna is a quadrafilar helical unit which in free space produces a circular polarized signal over a wide angle. The half angle of the zone at each pole, where antenna gain is in excess of 6 db below the gain of an isotropic radiator, is approximately  $20^\circ$  (upper) or  $10^\circ$  (lower), as shown in Fig. 8(b).

The placement of this antenna close to the spacecraft as shown in Fig. 6 results in nearly linear polarization, since the proximity of the large metallic surface produces an image to cancel one component of the wave. The reasons for mounting this antenna close to the sphere are discussed in Section XI.

#### VIII. BATTERY AND POWER SUPPLY

The Telstar battery consists of 19 series-connected nickel-cadmium cells. Each cell has a nominal capacity of six ampere-hours and weighs eight ounces unmounted. The battery was made of 19 individual cells having essentially matched characteristics. The main voltage regulator is designed for satisfactory operation with maximum loads with an 18-cell battery, so there is series redundancy of one cell.

The main regulator provides  $-16$  volts, regulated to  $\pm 2$  per cent. A minimum-loss design was of the greatest importance, and an efficiency of between 80 and 92 per cent is obtained as the output is varied from a light load to full load. There are two outputs from the regulator. The first output, feeding most of the solid-state circuits, has a ripple of less than 1 millivolt, rms. The other output is connected to the TWT supply.

The TWT supply is an unregulated dc-to-dc converter which provides heater, collector, helix and anode voltages for the tube. To conserve the life of the traveling-wave tube it is important that the voltages be applied and removed in a controlled time sequence. This is accomplished by commands from the ground which actuate magnetic latching relays within the satellite. Separate transformers for the high-voltage potentials are consequently required and are shown in Fig. 9. By use of new techniques in the oscillator portion of the converter it has been possible to achieve an efficiency as high as 70 per cent. The complete design of the regulator and converter is covered in another paper in this issue.<sup>10</sup>

#### IX. OVER-ALL STRUCTURE

As noted earlier, the structure of the Telstar satellite was determined largely by conditions inherent in the choice of the launch vehicle as

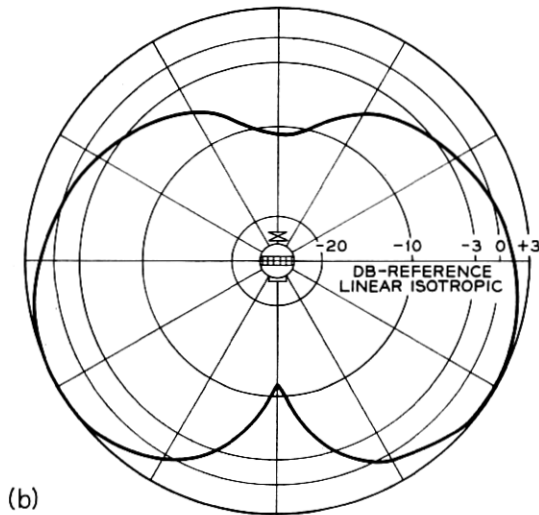
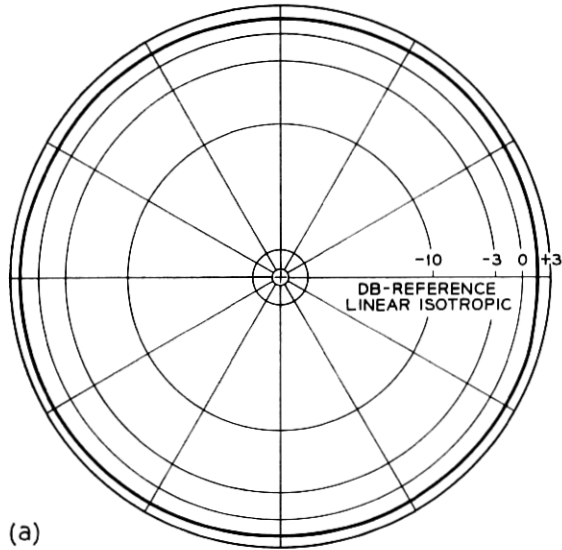

Fig. 8 — VHF antenna patterns: (a) equatorial aspect; (b) polar aspect.

well as fundamental decisions regarding the mission objectives. All studies and designs have been based on the use of the highly reliable Delta three-stage combination. Preliminary studies were directed toward an essentially spherical design with a diameter of about 27 inches and a weight of about 90 pounds. This early objective was a design that could



be accommodated in the low-drag fairing of the Delta vehicle. As more detailed examination of the electronics assembly progressed, it became apparent that the earlier proposals could not be attained within a reasonable schedule. It was then decided to examine the possibility of using a second nose fairing, originally developed for another program. This so-called "bulbous" fairing encloses more efficiently the volume needed for a spherical payload structure. With this alternative, a diameter of about 34 inches was made possible.

Concurrent with selection of the bulbous fairing, investigation was carried out on considerations of spacecraft weight versus orbital parameters. From this, it was established by engineers with NASA and

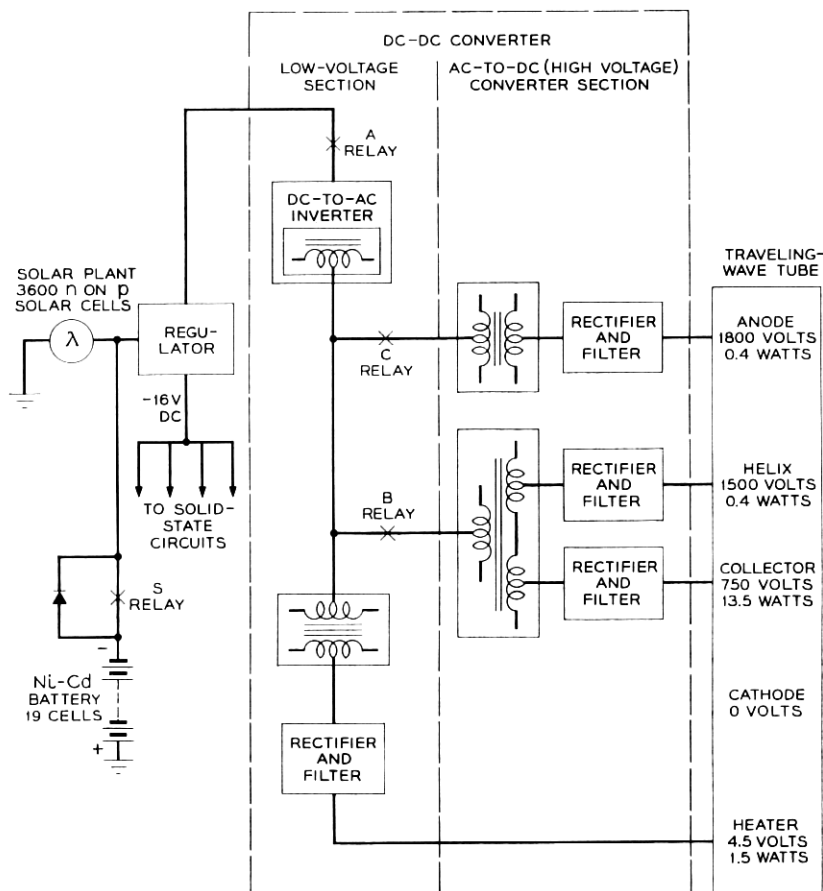

Fig. 9 — Power system.

Douglas Aircraft that a maximum payload of 180 pounds could be launched into an orbit consistent with the over-all objectives of the Telstar experiment. From design information available at that time, a maximum weight of 175 pounds was set as the limit for the Telstar spacecraft. Actual weights of six models completed for possible launch have ranged from 170.94 pounds for the model launched to 175.4 pounds.

The Telstar spacecraft structure was also influenced by the choice of spin stabilization, for which the reasons have already been discussed. The principal problems in this method are those related to dynamic and static balance of the payload about the spin axis and the requirement that the spin axis be that of major moment of inertia. As in most such designs, this is achieved by symmetry about the spin axis of the primary structure and judicious placement of masses not having natural balance by symmetry. Residual imbalance is, of course, removed by measurement and addition of trim weights as a final step in construction. In the satellite design, the major difficulty in optimizing the structure for spin stabilization was that of obtaining a low enough ratio of pitch to spin moments of inertia. A design requirement of 0.95 maximum was established and was attained with some compromise in performance of the VHF helical antenna. This antenna was to have been mounted on a telescoping mast and erected on firing a charge by closure of switches actuated by payload separation. Although the combined weight of mast and antenna was less than one pound, the effect on pitch moment was the deciding factor. The final mounting, although sacrificing 3 db in antenna performance, resulted in a more reliable design with an over-all saving in weight and an adequate ratio of pitch to spin moments. Mechanical and electrical testing were also simplified by this change.

In addition to spin-axis balance, the nearly spherical symmetry of Telstar is important in other respects. Foremost in these was the objective of near isotropy in the solar cell arrays.<sup>2</sup> The sphere-like outer shell permits placement of solar cell groups such that a reasonably uniform electrical output is obtained regardless of the relative orientation to the sun. The surfaces on which the solar cells are mounted are planar sections or facets rather than spherical sections. In this way all solar cells on a facet are illuminated to the same degree for maximum efficiency. The larger facets contain complete 72-cell groups (38 in number) while the 12 facets near each pole contain half-groups of 36 cells. The 24 half-groups combine in pairs to provide 12 complete groups, bringing the total to 50 groups providing 3600 cells. Facets not used for solar cell mounting and all other exposed outer surfaces are coated

with a plasma spray of aluminum oxide to effect the desired thermal balance.<sup>2</sup> Three facets carry optical mirrors for spin rate and orientation measurements by means of ground-based optical telescopes.<sup>11</sup>

The last factor to be discussed, wherein the choice of launch vehicle exerted particular influence, is related to the launch environment. Specifications covering shock and vibration tests had been effectively standardized for Delta missions and were invoked by NASA in the Telstar program. The severity of the tests for qualification of the prototype is 50 per cent greater than that for acceptance of models designated for launching. Included are random and sinusoidal vibration tests in three axes on all models. The prototype qualification tests also include constant acceleration and shock tests.<sup>12</sup> Levels of vibration input normal to the plane of the attachment fitting range from 2.3 g to 21 g between 5 and 2000 cps, with special requirements from 550–650 cps. In the latter range, a level of 40 g is used to simulate the resonant burning peculiar to the third-stage rocket. In order to isolate the sensitive electronics assemblies from the effects of shock and vibration, an isolation mounting comprising many strands of nylon cord was used. This support was designed to have a natural frequency of 40–45 cps, where the expected “g” input is of the order of 1.5 g along the spin axis. Maximum “g” levels experienced by the electronics assemblies due to qualification testing approach 20 g at resonance of the lacing support, while the higher-level inputs at frequencies above 50 cps are effectively damped, with occasional spikes of 5 to 10 g on the electronics section.

A simplified cross section showing relative positions of the major parts of the spacecraft is shown in Fig. 10. As shown, the electronics assembly occupies a large central volume of the structure. It is, in fact, a single assembly which is constructed and tested separately before insertion into the outer frame. All of the electronics subassemblies are contained in this “package” with the exception of portions of the radiation experiment, which had to be assembled close to detectors with which they were associated. The electronics package accounts for 85 pounds or essentially one-half the total spacecraft weight. Attached near the top and bottom of the cylindrical package are lacing rings through which the nylon lacing supports are stitched. The outer frame is a welded structure of magnesium tubing with an exterior skin of very thin aluminum panels. Whenever possible, these lightweight metals have been applied throughout for optimum utilization of their strength, weight, and heat conductivity, as applicable. Fabrication techniques and finishing problems were also of considerable importance.

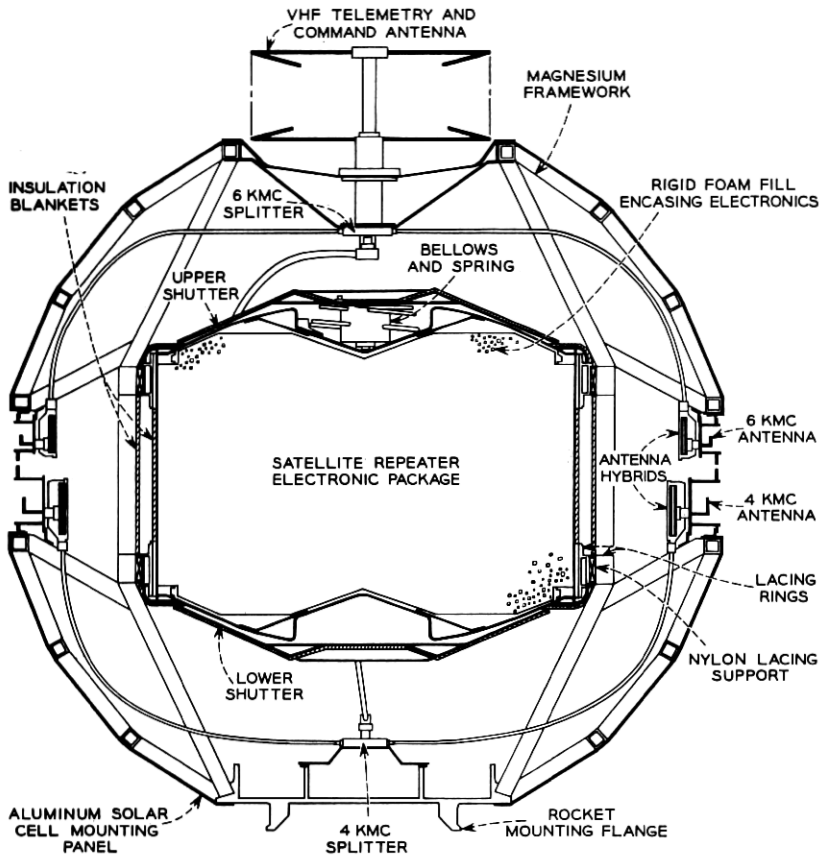

Fig. 10 — Cross section of spacecraft.

#### X. THE ELECTRONICS PACKAGE

The environment to be encountered during many months in orbit, as well as the conditions of launch, had strong influence on the design of the electronics package. The effects of high vacuum and Van Allen belt radiation on organic materials commonly used in electronic equipment were of particular concern. For this reason, many materials expected to be used in Telstar satellite designs were tested for the effects of radiation and vacuum. However, time did not permit adequate and conclusive tests on all such materials, especially since high-vacuum tests cannot be accelerated, but only extrapolated. This factor, coupled with the presence of high TWT voltages, led to the decision to enclose

the electronics in a hermetically sealed container which would carry an atmosphere into space. In this way, it could be assured that outgassing of organic materials would not contaminate finishes critical to thermal balance or solar cell operation. Also, any immediate hazard of high-voltage ionization and breakdown at low pressure was removed. While these were the primary objectives of the sealed container, fortuitous gains were improvement of shielding against electron radiation and completely valid tests of thermal characteristics on the laboratory bench.

Mention has been made of shock and vibration levels sustained by the electronics package during launch. In order that these inputs would not be further amplified by self-resonances within the electronics assembly, a somewhat radical approach was taken. In addition to the generally accepted procedure of encapsulating individual circuit packages, it was decided to fill the voids in the over-all assembly with polyurethane foam of the same type as that used for individual assemblies. This final encapsulation provided the major mechanical support for the TWT amplifier and waveguide components as well as for the transistorized units mounted with them. With the additional foam, the design of supporting brackets and testing for their adequacy could be minimized, if not ignored. Also, the retention of interconnecting wires prior to final encapsulation was essentially unnecessary. Consonant with this use of rigid foam is the avoidance of connectors except where essential to assembly and testing. All subassemblies are constructed with their wiring pigtailed from the units and color-coded. Interconnections are made with crimped sleeves covered over by heat-shrunk plastic tubing. The final assembly with foam fill in place might be equated to "launching" in the shop. However, repair, though difficult, is not impossible and the technique is believed to be consistent with the reliability objectives inherent in the program.

#### XI. THERMAL DESIGN WITHIN THE ELECTRONICS PACKAGE

Because of the almost complete filling of the electronics package with the rigid foam, appreciable heat transfer by gas convection cannot be expected. Hence, it was necessary to rely entirely on conductive heat transfer to remove power dissipated within the package to its outer walls, whence it could be radiated off. The comparatively massive waveguide structure (see Fig. 11), supplemented by heat conducting straps to attach it to the package cylinder wall, is the primary means of removing the heat. This was of particular significance at the TWT amplifier with a peak dissipation of 13 watts. Also, the chassis of a number of units, which accounted for the major part of the remaining dissipation,

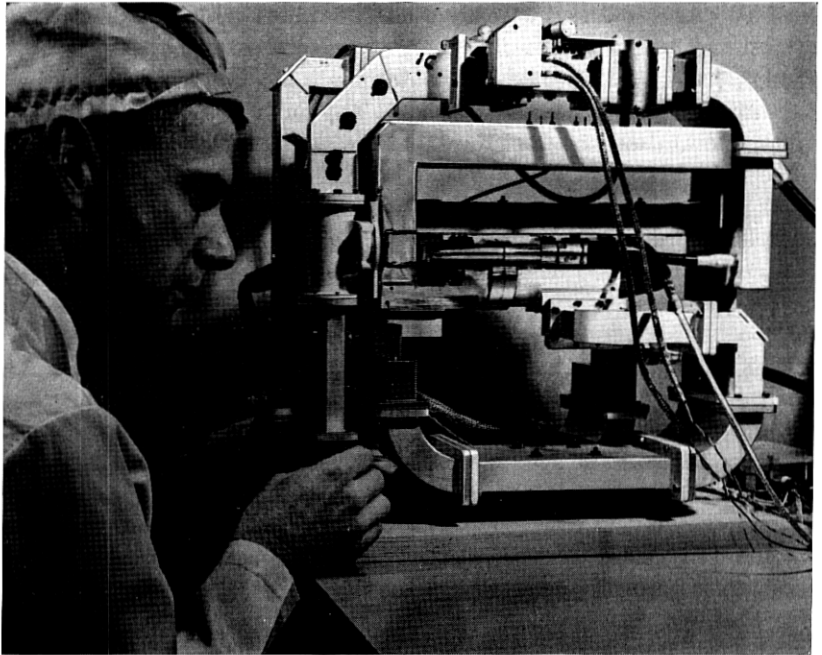
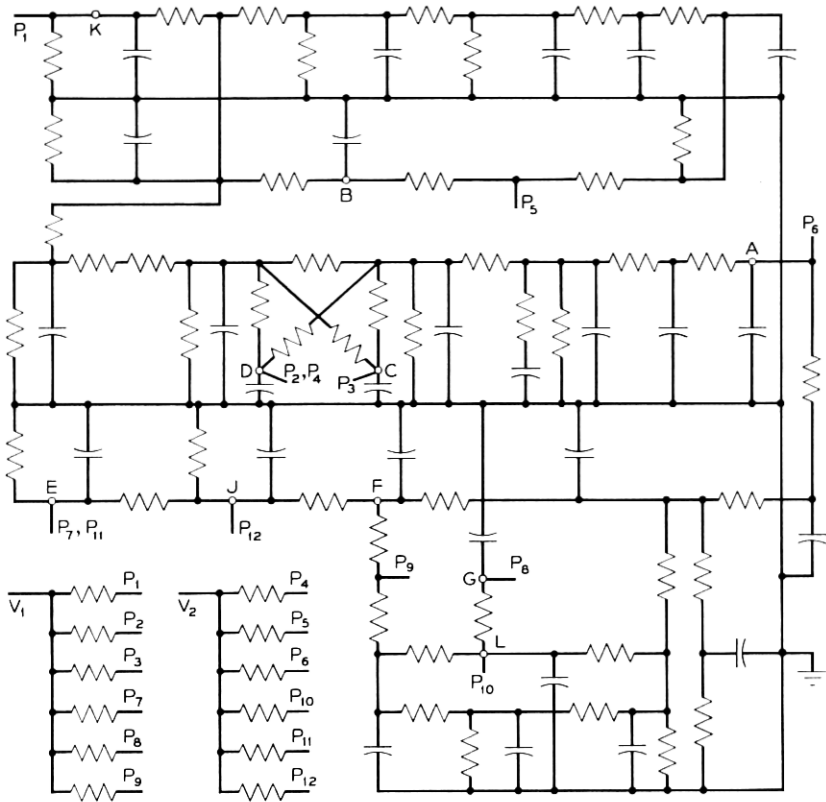

Fig. 11 — Waveguide structure.

were firmly attached to the waveguide structure. The power supply regulator was bonded directly to the cylinder wall, as were the cells of the nickel-cadmium battery. This treatment of the battery cells was most important, since during periods of overcharge almost all of the solar plant output may be dissipated in the battery as heat. Placing the cells in intimate contact with the cylinder wall avoided wide excursions in temperature at the cells. Similarly, the intimate bonding of all heat producing assemblies through the waveguide and package container avoided any significant localized heating, even with the peak dissipation associated with operation of the microwave repeater.

To verify the adequacy of the thermal design of the electronics package, an electrical analog was constructed of appropriate resistive and capacitive components and fed with currents corresponding to the various heat sources. The schematic of the analog circuit is shown in Fig. 12 with a table of current feed (temperature check) points. Continuously operating sources were separated from switched loads to permit precise simulation of operation in successive orbital passes. The electrical analog permitted evaluation in minutes of thermal charac-



ANALOG POINT	TEMPERATURE MEASURED	ANALOG POINT	TEMPERATURE MEASURED
A	NEAR TWT COLLECTOR	F	COMMAND RECEIVER
B	IF AMPLIFIER	G	COMMAND SWITCH CONTROL
C	VHF BEACON TRANSMITTER	J	TELEMETRY
D	BEAT OSCILLATOR SUPPLY	K	COMMAND DECODER
E	POWER SUPPLY REGULATOR	L	DC-DC CONVERTER

- NOTES**
1. CIRCUIT GROUND CORRESPONDS TO CANISTER OF ELECTRONIC PACKAGE
  2.  $V_1$  FEEDS CONTINUOUS LOADS AND  $V_2$  FEEDS LOADS SWITCHED BY COMMANDS

Fig. 12 — Electrical analog of thermal characteristics.

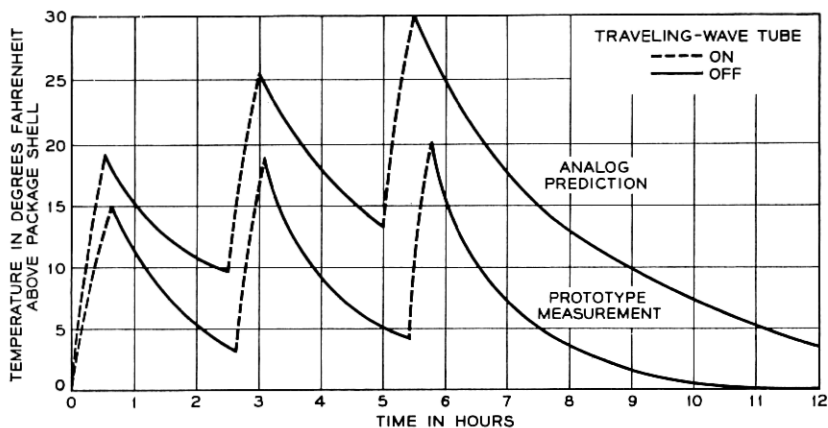

Fig. 13 — Predicted vs measured thermal performance of prototype spacecraft.

teristics actually realized in days (50 milliseconds = 1 hr.). Fig. 13 shows a comparison of results obtained at the TWT amplifier with the analog measurements to actual data obtained in thermal vacuum testing of the prototype model. The greater temperature rise shown by the analog data is indicative of the conservative approach taken in simplification of the analogous form. Temperature rises indicated by the analog, though consistently higher than actually realized, were within the objectives and confirmed the adequacy of the design.

## XII. SUBASSEMBLIES FOR THE ELECTRONICS PACKAGE

Some further details of the design of the electronics package are of interest. The progress of the assembly before final encapsulation is shown at three stages in Fig. 14. Top and bottom views of the completely assembled unit are shown in Fig. 15. To reduce weight, the waveguide portions are constructed entirely of magnesium with silver plating to improve electrical performance. A layout was achieved which, if laid straight, would exceed 13 feet of 1"  $\times$  2" waveguide, but in which only 1 foot is simple waveguide and is not functional as a filter or other such component. In addition to the waveguide, 16 electronic units and 19 nickel-cadmium cells are assembled in the package. These are tabulated in Table II together with their approximate weights.

The total weight of waveguide components is 9.9 pounds while the TWT amplifier adds 7.1 pounds. The complete sealed container for the electronics weighs 13.9 pounds, and the foam for the final encapsulation varies in weight from 7 to 8 pounds.



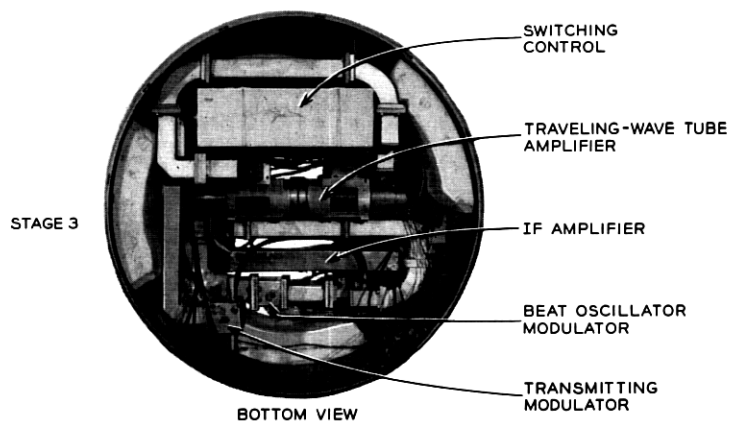
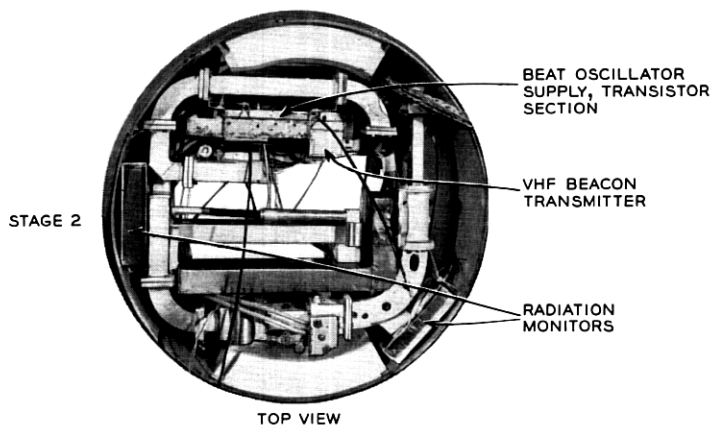
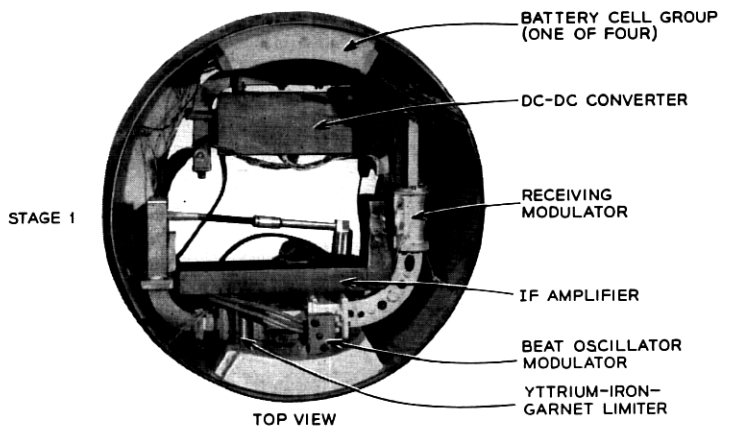

Fig. 14 — Assembly of electronics package.

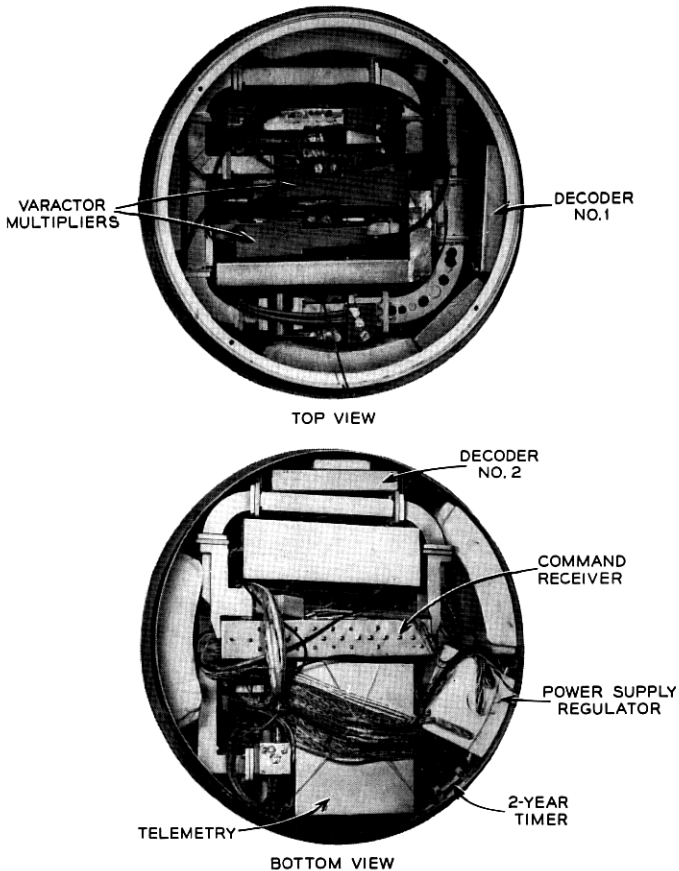

Fig. 15 — Completely assembled electronics package.

The designs of the individual units are quite varied in detail but fall into three principal categories:

(a) For high-frequency circuits such as the IF amplifier and beat oscillator supply, a fabricated aluminum chassis is used in conjunction with epoxy-glass boards for mounting. After wiring and testing, the structure is encapsulated with certain areas of the chassis exposed. Electrical shielding is then completed by a 0.003-inch aluminum cover. Cover and chassis are gold-plated to facilitate soldering the shield to the exposed chassis. A view of the IF amplifier before encapsulation and shielding is shown in Fig. 16.

(b) The second type is devoted to circuits lending themselves to modular construction, such as the decoder in Fig. 17. Small modules

TABLE II

Unit	Approximate Weight (lbs)
1. IF amplifier and AGC	1.2
2. B.O. supply	0.9
3. Varactor multipliers (2)	0.63
4. Command receiver	1.32
5. Command decoders (2)	1.98
6. Command switch control (2)	2.26
7. VHF beacon transmitter	0.9
8. Telemetry	8.5
9. Power supply regulator	4.0
10. DC-to-DC converter	2.92
11. Ni-Cd battery (19 cells)	11.25
12. Radiation particle counters (2)	1.65
13. Two-year timer	0.57

are encapsulated separately and grouped on unit boards to perform the more complex functions. After interconnection, board and modules are again encapsulated.

(c) The last type is best described as a free-form construction to accommodate components too varied in size and shape for strict organization. One or more insulating mounting boards are used with a single step of encapsulation completing the unit. One of three boards from the power supply regulator pictured in Fig. 18 is typical of these.

### XIII. CANISTER FOR THE ELECTRONICS PACKAGE

The container for the electronics package is made of  $\frac{1}{16}$ -inch 1100-type aluminum. The cylindrical section is fabricated of sheet with a seam

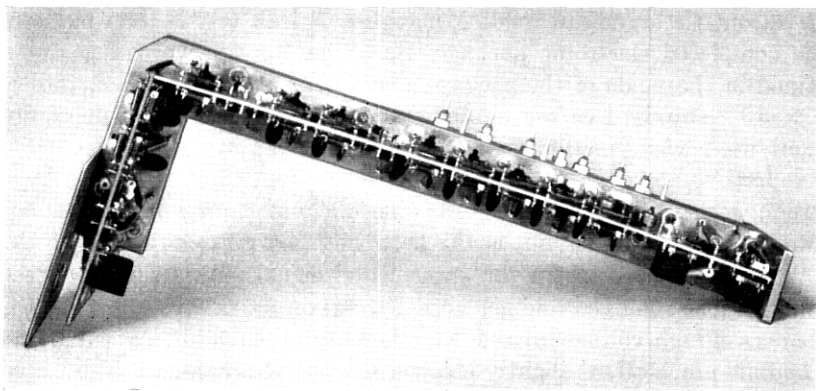

Fig. 16 — IF amplifier.

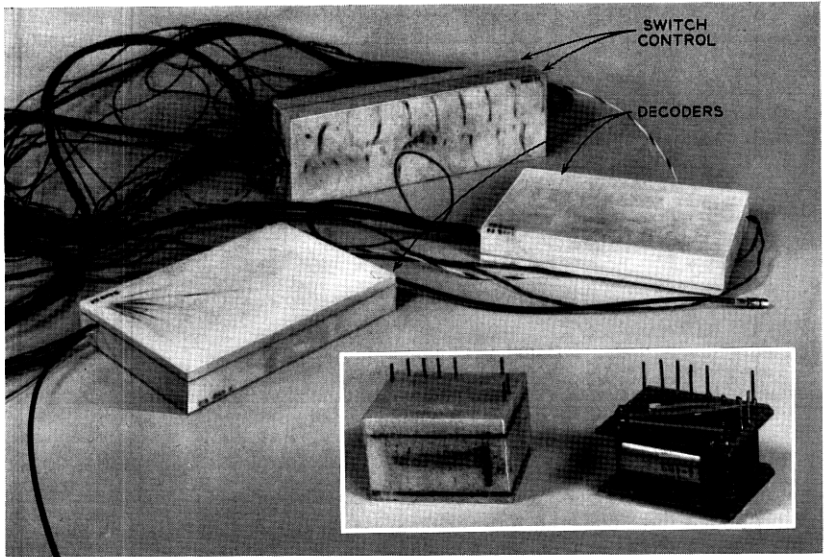

Fig. 17 — Modular construction — decoders and switch control.

weld, reinforced penetrations being provided at six locations for the electrical feed-throughs. The completed cylinder is gold-plated and polished on the exterior, after which glass-seal headers and coaxial feed-throughs are soldered into the penetrations. A helium leak check is made on each solder or glass seal before and after assembly and wiring. After foaming and temperature testing of the wired package, the top and bottom are closed by identical aluminum domes welded into place on an automatic argon-arc welding machine. A leak test is then made of the completed electronic package. Based on the reservoir of gas contained in the voids of the package assembly, a permissible leak rate of  $8 \times 10^{-5}$  standard cc/sec was computed for a 2-year life. The equipment used was sensitive enough to detect leaks in the order of  $10^{-6}$  standard cc/sec or about two orders down from the permissible leak. Argon is used to make this test, since helium cannot be introduced into the package (helium would penetrate the glass envelope of the TWT and cause noise in the transmitted signal). As a final step the argon is also removed and replaced by carbon dioxide to minimize the chances of high-voltage breakdown inherent in the readily ionized argon. The final pinch-off, at slightly below atmospheric pressure, is also tested for leak by monitoring rise in pressure in a known evacuated volume.

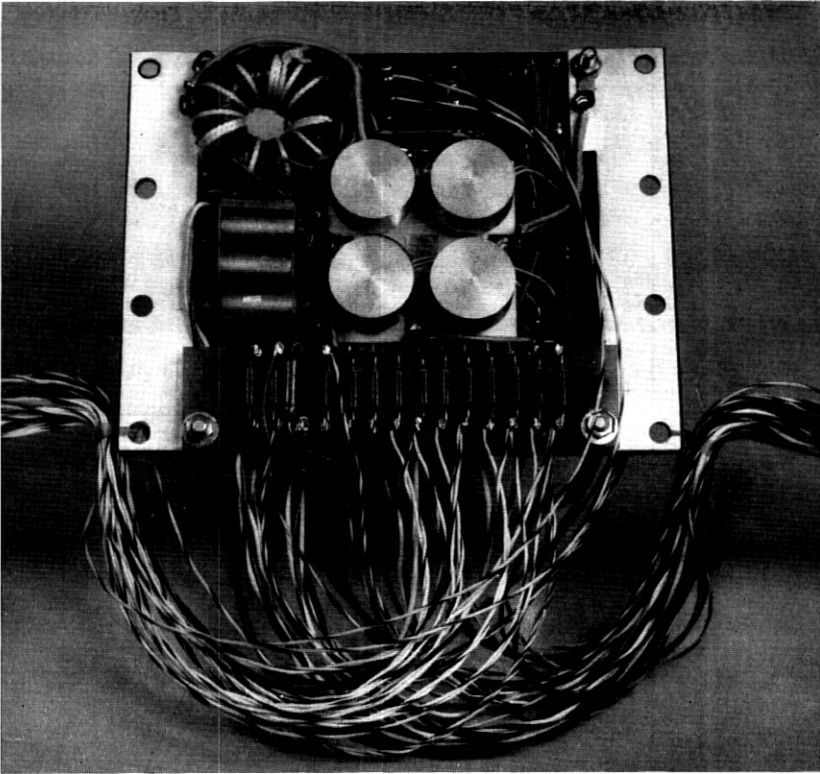

Fig. 18 — Free-form construction — portion of power supply regulator.

#### XIV. CONCLUSION

This paper has described the planning and general design of the Telstar satellite and attempts to give the reader an over-all picture of what the satellite contains. Several companion papers give very detailed descriptions of the various subassemblies and parts of the satellite. Another paper<sup>13</sup> discusses the importance of a reliable construction program. The relative simplicity and established performance of the circuit and equipment approaches described were basic to the development plan. Long life can best be attained, we believe, by a straightforward design based on a minimum of duplication and tried and proven design principles. The success of the Telstar program demonstrates the validity of this approach.

## XV. ACKNOWLEDGMENTS

As in any corporate effort, many people made significant contributions to those phases of work described in this paper. The leadership and guidance of Messrs. A. C. Dickieson and E. F. O'Neill in the planning and early system layout are particularly worthy of mention.

## REFERENCES

1. Hoth, D. F., O'Neill, E. F., and Welber, I., The *Telstar* Satellite System, B.S.T.J., this issue, p. 765.
2. Hrycak, P., Koontz, D. E., Maggs, C., Stafford, J. W., Unger, B. A., and Wittenberg, A. M., Spacecraft Structure and Thermal Design Considerations, B.S.T.J., this issue, p. 973.
3. Curtis, H. E., Interference between Satellite Communication Systems and Common Carrier Surface Systems, B.S.T.J., **41**, May, 1962, p. 921.
4. Sproul, P. T., and Griffiths, H. D., The TH Broadband Radio Transmitter and Receiver, B.S.T.J., **40**, November, 1961, p. 1521.
5. Davis, C. G., Hutchison, P. T., Witt, F. J., and Maunsell, H. I., The Spacecraft Communications Repeater, B.S.T.J., this issue, p. 831.
6. Bodmer, M. G., Laico, J. P., Olsen, E. G., and Ross, A. T., The Satellite Traveling-Wave Tube, B.S.T.J., this issue, Part 3.
7. Chapman, R. C. Jr., Critchlow, G. F., and Mann, H., Command and Telemetry Systems, B.S.T.J., this issue, p. 1027.
8. Brown, W. L., Buck, T. M., Medford, L., Thomas, E. W., Gummel, H. K., Miller, G. L., and Smits, F. M., The Spacecraft Radiation Experiments, B.S.T.J. this issue, p. 899.
9. Bangert, J. T., Engelbrecht, R. S., Harkless, E. T., Sperry, R. V., and Walsh, E. J., The Spacecraft Antennas, B.S.T.J., this issue, p. 869.
10. Bomberger, D. C., Brolin, S. J., Feldman, D., Trucksess, D. E., and Ussery, P. W., The Spacecraft Power Supply System, B.S.T.J., this issue, p. 943.
11. Courtney-Pratt, J. S., Hett, J. H., and McLaughlin, J. W., Optical Measurements on the *Telstar* satellite to Determine the Orientation of the Spin Axis and the Spin Rate, to be published.
12. Delchamps, T. B., Jonasson, G. C., and Swift, R. A., The Spacecraft Test and Evaluation Program, B.S.T.J., this issue, p. 1007.
13. Shennum, R. H., and Reid, E. J., The Design and Construction of the Electronics Package, B.S.T.J., this issue, Part 3.