

Digital Equipment for the Antenna Pointing System

By J. A. GITHENS and T. R. PETERS

(Manuscript received February 26, 1963)

This paper describes the digital control and data processing portions of the antenna pointing system used to track the Telstar satellite. The description is functional in nature, giving the form of the inputs, the functions performed, and the outputs produced. A general description of the digital equipment is followed by a discussion of the functions performed by the subsystems, the operational modes provided, the equipment features, and the operating experience.

I. INTRODUCTION

The primary function of the digital equipment in the Telstar antenna pointing system¹ is to generate pointing information for the horn-reflector antenna. The performance of this function requires the prediction of the ephemeris from previously acquired information on the satellite orbit. Together with the precision tracker² and the horn antenna,³ the digital equipment provides means for the acquisition, recording, and storage of the track information in each pass. These data are used to periodically up-date the parameters which describe the satellite's orbit. These updated parameters are the basis for the generation of the pointing instructions which are stored and used to control the horn antenna and precision tracker during future passes. During a pass the pointing instructions are synchronized with real time, interpolated to provide a smooth flow of data and then compared with the actual antenna position. To insure accuracy in the conversion of the digital pointing instructions to the analog inputs required by the antenna servo,⁴ the input comparison is performed digitally. The conversion to analog voltages is performed on the difference, or error, signals for which the accuracy requirements are not extreme. In addition, the digital equipment performs a variety of other functions which will be described in this paper.

In Section II a general description of the seven functional units mak-

ing up the digital equipment will be given. Sections III through X contain detailed descriptions of the operations performed by these functional units. The paper then discusses the configurations of these functional units as they are used to provide the various operational modes of the system (Section XI). The implementation of these functions and the equipment features are described (Section XII) and, in conclusion, operational experience is discussed in Section XIII.

II. GENERAL DESCRIPTION

The digital equipment is made up of seven functional units, or subsystems, as shown in the block diagram of Fig. 1.

2.1 Data Processors

The data processors are two general-purpose digital computer systems capable of performing the complex programs⁵ necessary to define the satellite orbit from track information, predict future passes, and generate the ephemeris for each pass of interest. Normally, the data processors, having completed their function prior to a pass, take no active part in the pointing during a pass.

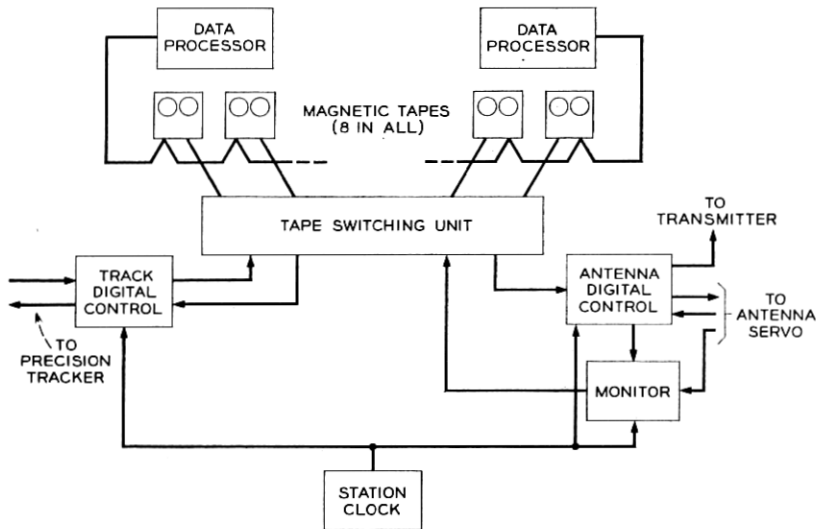

Fig. 1 — Digital equipment block diagram.

2.2 *Magnetic Tape Units*

The magnetic tape units together with the tape switching unit provide for storage and transfer of tracking data and ephemerides within the digital control and data processing system.

2.3 *Antenna Digital Control*

The antenna digital control (ADC) is closely integrated with the antenna servo, which is the actuator of the horn-reflector communications antenna. The ADC, reading pointing instructions from a magnetic tape, synchronizes the pointing operation with time, interprets the pointing instructions in the form and at the rate required by the antenna servo, and closes the servo position loop digitally so that the pointing is achieved with adequate accuracy. In reading the pointing instructions, it performs a variety of tests to check the validity of the data. Careful checking is necessary, because the information is transmitted 1600 feet from the control building and through a slip-ring assembly to the ADC equipment on the antenna structure. Pointing instructions are recorded on tape for each four seconds of the pass, and the ADC provides an interpolator which, using this information, produces position commands at the 128 per second rate required by the antenna servo. Experience has shown that the predominant orbit prediction error is usually in time, and the ADC incorporates means for manually offsetting the predicted pointing instructions in time. This allows the operator to reduce these prediction errors. The ADC also includes features which allow the antenna to be manually offset in position from the predicted track. To meet the system accuracy requirements, the ADC performs the servo position summing operation by comparing the commanded position, as determined from the pointing instructions and the offsets, with the actual antenna position. The actual antenna position is determined from data pick-off units in both axes whose outputs are digitally encoded by the ADC with a precision of 0.003. Only after the position differences, or errors, have thereby been determined, and the need for extreme accuracy reduced, are the ADC outputs converted to analog voltages as inputs to the antenna servo. The output of the ADC may be used in three ways by the antenna pointing system: (a) as the sole source of pointing information; (b) with the autotrack⁶ system to provide a combined source of control, in which the autotrack tends to correct for errors in the pointing instructions from the magnetic tapes; and (c) as a means for acquisition of the satellite beacon by the autotrack system, after which autotrack has complete control and the ADC outputs are used only as back-up.

2.4 *Monitor*

The monitor records on tape all the pertinent information on tracking performance from the antenna digital control and the antenna servo. The data processors use the monitor tapes as one source of track data and as a means of performance analysis.

2.5 *Track Digital Control*

The track digital control (TDC) records on tape the precision tracker positions during the pass and provides the data processors another source of track information. These positions are also available in real time as a source of pointing instructions for the horn antenna. This provides a means of slaving the horn antenna to the precision tracker. The TDC also performs a pointing function for the precision tracker similar to that which the antenna digital control performs for the antenna servo and the horn antenna. It provides means for controlling the precision tracker from pointing information stored on magnetic tape. Though the command tracker⁷ is not controlled directly by the TDC, it can be slaved to the precision tracker and thereby pointed indirectly by the TDC for acquisition purposes.

2.6 *Tape Switching Unit*

The tape switching unit provides facilities for connecting any of the eight tape units to the antenna digital control, monitor, or track digital control.

2.7 *Clock*

The station clock provides the basic time reference for the system, so that operation may be accurately synchronized with Universal Time.

2.8 *Acquisition Aids*

The digital equipment provides several features to aid in acquisition when the orbit is not precisely known. Since the precision tracker has a relatively broad beam (2°) compared to the beam of the horn-reflector antenna, (0.2°), it can be used as an acquisition aid. This is accomplished by slaving the horn antenna to the precision tracker and performing the initial acquisition of the satellite beacon with the precision tracker. This is called the "PT command" mode. The encoded precision tracker positions produced in the track digital control are used as the command input

in the antenna digital control. The accuracy of the tracker is such that this places the horn antenna well within the acquisition range of the horn autotrack system. A second form of slave operation, initial mode, is possible, in which the data processors are used in real time. In this mode, position information from the track digital control is read directly into the data processors. They smooth the data, perform a short-term prediction and drive the antenna digital control directly with pointing information. This mode yields smoother operation than the PT command mode, since the precision tracker tracking jitter is removed and rate information is supplied.

To aid in acquisition, the antenna servo includes facilities for generating a spiral scan pattern for the horn antenna. The outputs of the spiral scan generator are spiral velocities which are integrated in the antenna digital control and used to offset the programmed position.

In the sections which follow, the functions performed by the seven digital subsystems are described.

III. DATA PROCESSORS

The data processing portion of the antenna pointing system consists of two IBM 1620 Computer systems. Each computer system consists of an IBM 1620 central processing unit, an IBM 1623 core storage unit, an IBM 1622 card reader-punch, and an IBM 1921 tape adapter unit. The 1620 is a desk-sized, solid-state, decimal machine with 20,000 characters of internal magnetic core storage. These units have been equipped with the floating point and automatic divide options. The 1623 core storage unit adds 40,000 characters of core storage, giving each computer a storage capacity of 60,000 characters. The 1921 unit adapts each system for magnetic tape operation and is capable of handling six tape units. The 1622 units provide the systems with card input and output capabilities. The computing systems are pictured in Fig. 2.

The on-site facilities include an IBM 407 printer and an IBM 026 punch. In addition, IBM 7701 magnetic tape transmission terminals working into DATA-PHONE links to the Whippany and Murray Hill Laboratories permit the IBM 7090 computing facilities at these locations to be used as back-up for the on-site facilities.

The primary function of the data processors is to keep an accurate, up-to-date record of the satellite's orbit from which it can predict future passes and generate precise pointing instructions for the site antennas. The orbit is described by a set of basic orbital elements. These elements, or orbit parameters, are periodically refined and updated by the data



Fig. 2 — Two computing systems with four tape units each; three cabinets between tape units contain tape switching equipment.

processors using track information recorded during previous passes by the track digital control and the monitor. The updated orbital elements then are used to predict the upcoming pass and to prepare the mission tape, which contains the pointing instructions. In addition to these functions, the data processors are used for data reduction and performance analysis.

IV. MAGNETIC TAPE UNITS

The Andover installation uses eight IBM 729-II magnetic tape units, shown in Fig. 2. These units are equipped with a switching option which permits each unit to be connected to either the data processors or the digital control. Four units are assigned to each of the data processors. When connected to the digital control, any one of the eight units may be connected by the tape switching unit to the antenna digital control, monitor, or the track digital control input or output. When so connected the tape units operate under the control of these units; the antenna digital control and track digital control input can read tapes and the monitor and track digital control output can write tapes. The low-density mode is always used on these tape units, so that the tape information rate is 15,000 characters per second.

V. MISSION TAPES

The end product of the data processors' efforts is the mission tape for each communications pass. The mission tape, with its pointing instruc-

tions, is the primary input to the antenna digital control and the track digital control. The mission tape consists of data points containing time, pointing angle, and rate information. Normally, a data point is recorded for each four seconds during a pass. To provide for error correction, the information in each data point is recorded redundantly as three separate tape records called blocks. Thus, each data point consists of three redundant blocks of information.

The time information in each block specifies, with a precision of $1/256$ second, the time at which the pointing information in that block is to be used. The time information is called tape time. The pointing information consists of azimuth and elevation position, velocity, and acceleration commands. Range information also is given in each block. In addition, compensation factors, somewhat inappropriately called predistortion information, are included in each block. These are correction factors to be added to the pointing information to compensate for mechanical distortions in the horn antenna that cause the electrical axis to differ from the mechanical axis. The use of these factors is discussed further in a later section.

In addition to the time and pointing information, each data block includes a number of unique tape characters called tags. One of these tags identifies the block as the first, second, or third block of a data point. Another tag indicates the checking mode to be used. There are a number of other tags which identify the different types of information and are used to control the disposition of the information by the input circuits.

VI. ANTENNA DIGITAL CONTROL

The antenna digital control equipment is shown in Fig. 3 and is represented by the simplified block diagram of Fig. 4. In this diagram, the antenna digital control (ADC) is shown as three blocks: the input circuits, the ephemeris interpolator, and the output circuits. When a mission tape is connected to the ADC by the tape switching unit, the magnetic tape unit operates under the control of the ADC input circuits. As data blocks are read, the input circuits perform the following functions.

6.1 *Data Checking*

Before a data block is accepted, it is carefully inspected to determine its validity. The following checks are performed.

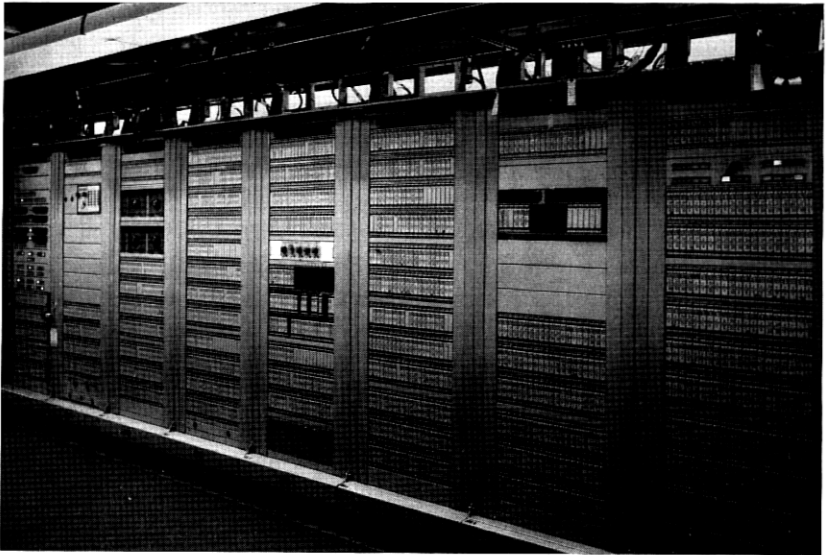

Fig. 3 — Antenna digital control equipment: seven racks at left house ADC equipment; right-hand rack houses monitor equipment.

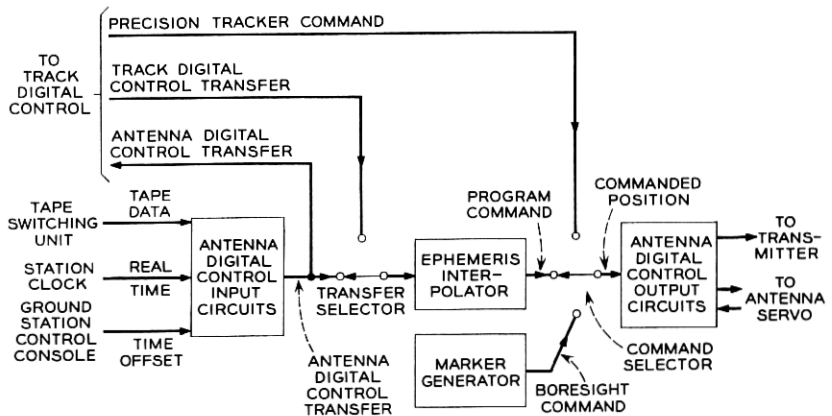

Fig. 4 — Antenna digital control block diagram.

6.1.1 Parity Checks

Since the tapes being read in this operation have been written on IBM equipment, the IBM parity checking conventions are used. Each data block is recorded with two forms of parity check bits, the "vertical" check bits and the "longitudinal" check bits. In the vertical parity check

each tape character is recorded with a parity bit which makes the number of ones in that character even. In the longitudinal parity check, an additional tape character is recorded at the end of each tape record (each data point block in this case). A tape record consists of a sequence of seven-bit tape characters recorded on tape in seven channels. Each bit in the longitudinal check character is chosen to make the number of ones in each channel of the record even. The longitudinal check character thus serves as a check on the block as a whole.

In the reading operation, each character and each channel are inspected to determine that the number of ones is indeed even. As a block is read it is written into buffer storage. As the block is read from the buffer memory, the parity of each character is again inspected to check on the storage operation.

6.1.2 *Time Checks*

As data are read in, the time information in each data block (tape time) is checked against Universal Time. Two checks are performed. In the unconditional time check, the tape time is examined to see that it is later than Universal Time. If tape time were earlier than Universal Time it would represent an impossible situation, since time always advances, and data blocks containing such information are rejected. The second check is called the conditional time check, in which the tape time is inspected to see that it is not later than Universal Time by more than 20 seconds.

6.1.3 *Reasonableness Check*

To check the validity of the commanded data in each data block, the change in position commanded is compared with the previously ordered velocity. This check is performed by subtracting the new position command from the previously accepted position command and comparing this difference with the previously accepted velocity command. If the difference exceeds the maximum acceleration to be expected with the orbits under consideration, the data block is rejected as unreasonable.

6.1.4 *Checking Modes*

Each data block contains a tag character specifying the checking mode to be used by the ADC in checking the data. Two checking modes are used: in the first mode all of the above checks are performed, and in the second the results of the reasonableness and conditional time checks are ignored. The second checking mode is used for data points immedi-

ately following track discontinuities, such as are encountered in shifting between stars in star-tracking routines, where the discontinuities would cause good data points to be rejected due to the reasonableness criterion. This checking mode also can be used for data points following initial pointing commands by which the antenna is brought to the initial pointing angles more than 20 seconds before the start of a pass. This makes it unnecessary to program data points for every four seconds to command the same position until the start of the pass. This second checking mode also makes possible the use of lower data rates.

Data blocks are always rejected if there are parity errors or unconditional time errors. When operating in the first checking mode, rejection of two successive data points (six blocks) causes cancellation of the reasonableness and conditional time checks until a data block is accepted. In other words, after rejection of two successive data points, the checking operation reverts automatically to the second checking mode until a data block is accepted.

6.2 *Compensation Factors*

The most critical surface on the horn-reflector communications antenna is the reflector surface. During construction, the panels making up this surface were very carefully aligned to about 0.06 inch. Yet this is a very large surface, about 70 feet by 100 feet, and as the antenna is rotated in elevation the force of gravity acts on the structure at different angles, causing minute distortions in the surface. These distortions cause the electrical axis of the antenna beam to differ from the mechanical axis, and it was necessary to calibrate the antenna so that these deflections could be compensated for in pointing the antenna. The calibration was measured by tracking radio stars of known positions using radiometry techniques.⁸ The calibration thus determined is stored in the data processors as an empirical function of antenna elevation angle. As data points are recorded on the mission tape, the data processors add this calibration information. With only a single communications antenna, as in the present installation, these factors could be added directly to the pointing commands. However, when more than one antenna is in operation at a site, the data processors in preparing the mission tapes have no way of knowing which antenna will be used. Anticipating this requirement, the data point format provides for the transmission of the calibration factors as separate items tagged for each antenna. As the data are read by the ADC input circuits, the calibration factors for the particular antenna controlled by that ADC are selected and added to the

pointing commands. Since these factors can be significantly large at high elevations, velocity and acceleration factors, as well as position factors, are necessary if a smooth track is to be obtained.

6.3 *Time Offsets*

The ADC input circuits provide the facility for offsetting Universal Time received from the station clock a total of plus or minus 1 minute, 59 seconds in one-second steps. This facility is provided because experience indicates that the predominant orbit prediction error is usually in time. The time offset is under the control of the ground station control console.

6.4 *Time Synchronization*

The ADC input circuits perform the important function of synchronizing the operation with time. As a good data block is read by the ADC input circuits, it is stored in memory and the tape time is examined 256 times per second and compared with the offset Universal Time. When an exact comparison is obtained, the command data are transferred to the ephemeris interpolator.

6.5 *Ephemeris Interpolator*

While data points are received generally once every four seconds, the antenna servo requires information at a rate of 128 per second. The function of interpolating the command data between data points is performed by the ephemeris interpolator. The ephemeris interpolator performs a quadratic interpolation, using incremental or digital differential analyzer techniques, and produces azimuth and elevation position and velocity commands 128 times per second. The interpolation is performed with a precision of 0.003° in position as long as the velocity does not exceed $0.49^\circ/\text{sec}$. For higher velocities, the interpolation is performed with 4 times the granularity, or with a precision of about 0.01° . The use of a quadratic interpolation permits several consecutive data points to be rejected without affecting system accuracy.

As shown in the block diagram of Fig. 4, the input to the ephemeris interpolator can come from one of two sources, depending on the position of the transfer selector. With the selector in the position shown, the interpolator receives command data from the ADC input circuits. In the other position the command data are received from the track digital control input circuits. Similarly, command data are transmitted to a transfer

selector in the track digital control. The use of these selectors will be discussed further in the section on operating modes.

The output of the ephemeris interpolator is called the program command. It is one input to the command selector.

6.6 *Manual Position Offsets*

The command selector provides the command input to the ADC output circuits (Fig. 4). One of three inputs can be selected. The switch position shown is considered the normal position with the ephemeris interpolator providing the program command as input. With the selector in the PT command position, precision tracker encoded positions from the track digital control provide the commands. In the boresight command position, the selector provides position commands from memory which serve to bring the horn antenna to the boresight tower coordinates for testing and calibration routines.

The input provided by the command selector is called the "commanded position." The ADC output circuits provide a means for manually offsetting this commanded position in either axis. Two offsets are provided. One offset can be controlled from the ground station control console and either offset may be operated from the antenna control test position. The offsets can be inserted at two fixed rates of 0.01° and 0.75° per second. A control is provided to reset either offset in either axis to zero.

6.7 *Digital Integrator Offsets*

The ADC output circuits provide a digital integrator for each axis for use by the antenna servo in the spiral scan and autotrack. A digital integration is used to provide a drift-free integrator, and is performed by a simple accumulation technique. The integrators can be shared between the spiral scan and autotrack because these functions are never performed simultaneously. The switching between the two inputs to the integrators is performed in the antenna servo equipment. Thus, when the input is the spiral scan velocities, the integrator yields the spiral scan position offsets to the program command. When the input is the autotrack system instantaneous error, the integrator output is the integrated autotrack corrections, or offsets, to the commanded positions. The digital integrator thus develops and remembers the long-term difference between the predicted track and the actual track of the satellite as determined by the autotrack. When the manual offsets are zero, this long-term difference provides a measure of the accuracy of the track prediction.

The integration is performed by encoding the input provided by the antenna servo and simply adding the encoded quantity to the accumulated sum held in memory. The encoding and summing is performed 128 times per second. The smallest value encoded (the least significant bit) corresponds to 0.0000215° ($2^{-24} \times 360^\circ$). However, the smallest value considered in determining the position error is 0.00275° ($2^{-17} \times 360^\circ$) and, therefore, the smallest digital integrator offset must persist for 128 encodings, or 1 second, for it to have an effect on the position difference. The maximum encoded input corresponds to 0.00135° , and this value must persist for only two encodings, or $1/64$ second, to be effective. Maximum input errors result in position corrections at a rate of 0.175° per second.

6.8 Position Encoding

The ADC output circuits provide the facilities for encoding the horn antenna azimuth and elevation positions. The data pickoff units, which are a part of the antenna servo, produce pulse-position-modulated pulses from a two-speed resolver pickoff on the data gears. The position of the "stop" pulses relative to a reference "start" pulse is proportional to the angular rotation of the data gears and, hence, the position of the antenna. The digitizing of these time intervals is performed by high-speed counting (approx. 2 mc) in two counters, one for fine and one for coarse.⁹ The two counts are combined to give a 17-bit binary representation of antenna position. The precision of encoding is 0.00275° ($2^{-17} \times 360^\circ$) and the resultant accuracy is $\pm 0.005^\circ$.

6.9 Servo Summing Node

One of the most important functions performed by the ADC output circuits is the implementation of the major servo position summing node for the antenna servo. This operation is performed digitally for accuracy reasons 128 times per second for each axis; it is performed with a precision of 1 part in 131,072 (17 bits).

The servo summing node is illustrated diagrammatically in Fig. 5. The first input is the position command from the command selector. Remember that this input may be the program command, PT command, or boresight command. To the position command is added the sum of the two manual position offsets to produce what is called the offset position. To the offset position is added the output of the digital integrator, the digital integrator offset, to produce what is known as the corrected position. Thus, the corrected position is the offset position corrected by the long-term difference determined by the autotrack and

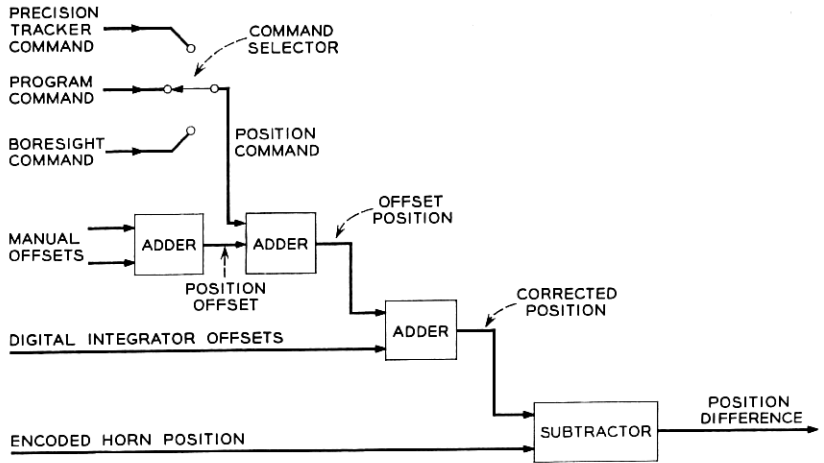

Fig. 5 — Digital servo summing node.

accumulated by the digital integrator. The corrected position, therefore, represents the system's best estimate of the satellite's actual position. Finally, the encoded horn position is subtracted from the corrected position to produce the position difference, the error in the position of the horn. Once the position difference is derived, the need for high precision is removed since the errors are small and they may now be stored and decoded to analog voltages for use by the antenna servo.

6.10 Velocity Error

The ADC output circuits determine the velocity error by comparing the actual antenna velocity in each axis with the commanded velocity. The actual velocity is determined by differencing the encoded horn positions 32 times per second, and the velocity error is produced with the same frequency. It is made zero unless the position error is coarse (greater than 0.35°). It is used by the antenna servo to eliminate overshoot as the horn slews to a commanded position.

6.11 Servo Difference

Under normal circumstances, if the ephemeris interpolator is working properly, the interpolated commands should agree closely with the new values brought in as each data point is transferred. The difference should not be more than one bit (0.00275°). However, if for some reason several

consecutive data points are rejected, when a new data point is finally accepted a significant difference may exist between the last interpolated point and the new accepted point since the quadratic interpolation may not perfectly describe the actual track. This difference has been termed the servo difference.

If the autotrack is inserted and in phase-lock when this happens, the variation of the interpolated command from the actual track will be compensated by an offset from the digital integrator. It would not be desirable, under these conditions, for the acceptance of a new data point to cause an abrupt jump in the position difference. Therefore, whenever autotrack is inserted and in phase-lock, any difference between the last interpolated point and a new data point is subtracted from the digital integrator contents and the new data point used as the program command. There is no net change in position difference. The result is the same as if the jump were allowed to occur and the autotrack then corrected by making a compensating change in the digital integrator offset. However, the possibility that the step change in position difference would cause the autotrack to drop track is avoided.

6.12 *Error Registers and Digital-to-Analog Conversion*

The ADC outputs to the antenna servo are fine and coarse position differences, and velocity errors in both axes. These signals are delivered as voltages. To produce voltages proportional to these digital quantities, the ADC output circuits provide storage and digital-to-analog conversion circuits. The storage is provided by flip-flop registers. The conversion is performed by constant-current, ladder-type resistance networks which provide a decoding accuracy of 1 per cent. To decode each quantity, two decoding networks, one for positive values and one for negative values, are used to avoid difficulties with zero drift.

6.12.1 *Position Errors*

The fine position error decoders in each axis produce a voltage output of the form shown in Fig. 6(a). As can be seen in this figure, errors less than 0.7° produce a voltage proportional to the error. For errors greater than 0.7° , the output is saturated at 5 volts. As is characteristic of digital-to-analog converters, the voltage produced is actually a staircase where the granularity is 0.02 volt, corresponding to error quanta of 0.00275° .

The coarse decoder output is shown in Fig. 6(b). This output is made zero until the error equals 0.35° . The voltage is then proportional to the

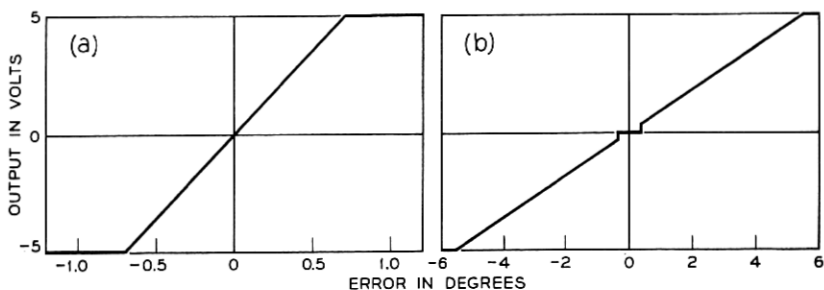

Fig. 6 — (a) Fine position error output; (b) coarse position error output.

error until it saturates at 5 volts for errors greater than 5.6° . In this decoding the 0.02-volt granularity corresponds to steps of 0.02° in error.

6.12.2 Velocity Errors

The outputs of the azimuth and elevation velocity error decoders are made zero until the position errors exceed 0.35° . Thereafter, the voltage outputs are proportional to the velocity errors. The maximum voltage of 5 volts corresponds to a velocity error of 2.8° per second. The granularity of decoding is 0.08 volt, corresponding to error quanta of 0.04° per second.

6.12.3 Range Decoding

In addition to the outputs to the antenna servo, the ADC output circuits provide a voltage proportional to the range information to the transmitter equipment in the antenna upper room. The range information is proportional to the ratio of the predicted slant range to a fixed range whose value depends on the type of transmission to be used. This output is used to program the transmitted power so that the input signal to the satellite remains essentially constant. The range information is supplied as a part of each data point. The range information is not interpolated but is set into the range register each time a new data point is transferred to the ephemeris interpolator. Thus, in general, the range register is updated once every four seconds.

VII. MONITOR

The function of the monitor is to record on magnetic tape all information on the horn antenna pointing operation that will be useful in orbit

determination and post-run performance analysis. Three types of information are recorded: digital information from the antenna digital control; analog information from the antenna servo, autotrack, and the communication equipment; and telemetry information from the satellite as received and decommutated by the telemetry equipment. The analog information is digitized for recording purposes by an analog-to-digital converter which provides facilities for converting and multiplexing as many as eight channels of analog information.

The digital information recorded includes the time, time offset, and the horn position in both axes. In addition, the acceleration, velocity, and position commands in both axes are included, as are the digital integrator offsets and the two manual offsets. The position differences, the range information, and the checking mode in use by the antenna digital control also are recorded. In other words, everything of interest is recorded.

Eight analog quantities may be recorded. While the quantities to be recorded are easily changed for testing purposes, the autotrack instantaneous errors, the receiver AGC voltage, an indication of autotrack phase-lock status, and the radiometry output (used in star tracking routines) are regularly recorded. The other three channels can be used for test voltages.

The telemetry information from the satellite is received, decommutated, printed, and punched on teletypewriter tape by the telemetry equipment in the control room. This same information is recorded on the monitor tape because the magnetic tape recording provides a more convenient input for computers than does the teletypewriter tape.

In its normal operating mode the monitor samples and records the digital information once per second as a separate tape record. The analog information is sampled seven times per second and the data recorded as two separate tape records. Since there is no synchronization between the monitor operation and the telemetry information, each channel of telemetry data is appropriately tagged and recorded at the end of the next digital or analog record to be recorded.

The monitor has facility for several other modes of operation at different sampling rates that are useful in testing and system checking routines. The monitor equipment is shown in Fig. 3.

VIII. TRACK DIGITAL CONTROL

The track digital control performs functions for the precision tracker similar to those performed by the antenna digital control and monitor

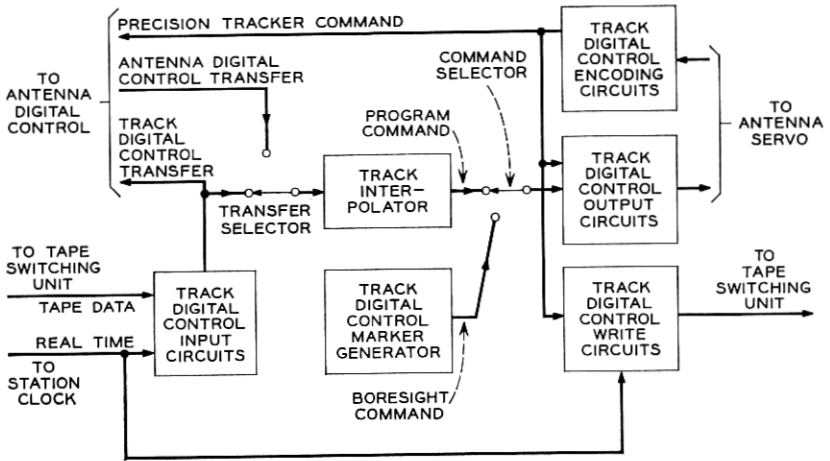

Fig. 7 — Track digital control block diagram.

for the horn antenna. The track digital control is considerably simpler, however, since it serves only as an acquisition aid to the precision tracker.

A block diagram of the track digital control (TDC) is shown in Fig. 7. It is quite similar to the block diagram of the antenna digital control except that the position encoding circuits are shown as a separate entity rather than as part of the output circuits. Also, there is an additional block, the write circuits, which performs a function similar to that of the monitor.

8.1 Data Checking

The TDC input circuits are similar to the antenna digital control input circuits except that the TDC input circuits perform no reasonableness check. The parity and time checks performed are identical to those performed by the antenna digital control input circuits. Similarly, there are two checking modes but, in this case, the second checking operation cancels only the conditional time check since the reasonableness check is never performed in any event.

8.2 Time Synchronization

The TDC input circuits do not make use of the predistortion information in the data points and do not have any provision for adding time offsets. The time synchronization operation, however, is identical to that

performed by the antenna digital control input circuits. Thus, the output of the TDC input circuits is the command data at the tape time specified in the data point. The data are not predistorted and the time of transfer cannot be offset.

Like the antenna digital control, the TDC input circuits output feeds a transfer selector. The other input to the selector is the output of the antenna digital control input circuits.

8.3 *Track Interpolator*

The track digital control interpolator performs a linear interpolation. That is, unlike the ephemeris interpolator, it makes no use of the acceleration information in providing position commands 128 times per second. The track interpolation is performed with a precision of 0.01° .

The output of the track interpolator feeds one input of the command selector.

8.4 *Position Encoding*

The position encoding performed in the TDC is identical with that performed in the antenna digital control. The result is a 17-bit encoding of the position in each axis 128 times per second. The position encoding circuits are shown as a separate block in the TDC block diagram because, in addition to feeding the summing node in the output circuits, the output feeds the write circuits and also is sent to the antenna digital control as the PT command.

8.5 *Summing Node*

One input to the TDC output circuits is the output of the command selector. The TDC command selector has only two positions and may select either the commanded positions from the track interpolator or the precision tracker boresight coordinates from the marker generator. The TDC command selector is under the control of the precision tracker operator.

The TDC output circuits are quite simple compared to the antenna digital control output circuits. No provision is made for manually offsetting the commanded position, and there is no feedback from the precision tracker equivalent to the horn-reflector autotrack. The summing node consists of a single subtractor which subtracts the precision tracker encoded position from the commanded position.

8.6 *Error Registers and Digital-to-Analog Conversion*

The position error output of the summing node is stored and decoded to provide voltage error signals in each axis to the precision tracker. The voltages are proportional to the errors for errors less than 5.6° . For errors greater than 5.6° , the voltage saturates at 5 volts. The granularity of the decoding is 0.02 volt for error quanta of 0.02° .

8.6.1 *Range Decoding*

The TDC output circuits decode the range information in the data points in exactly the same manner as the antenna digital control output circuits. The decoded range information is used by the precision tracker to estimate the signal-to-noise ratio.

8.7 *Track Write Circuits*

The TDC write circuits perform a track recording function for the precision tracker similar to that performed for the horn antenna by the monitor. The write circuits include a tape write control capable of controlling the recording on a magnetic tape unit connected to it by the tape switching unit. Time, azimuth position, and elevation positions are sampled and recorded as a tape record along with four binary control indications. Samples can be taken at 1, 2, or 4 per second with 2 per second being considered the normal rate. Two of the control bits define the precision tracker status by indicating when it is in autotrack and when the signal-to-noise ratio equals or exceeds 5 db. The third indicator is used in precision tracker optical star tracking routines, and the fourth is used as a control in the initial mode operation described in a later section.

IX. TAPE SWITCHING UNIT

The tape switching unit (pictured in Fig. 2) provides the facility for selectively assigning control of any of the eight magnetic tape units to antenna digital control input circuits, track digital control input circuits, monitor, or track digital control write circuits. To make this possible, the tape switching unit also performs the important function of level shifting to make the tape unit signals compatible with the digital control circuit levels and vice versa. The tape switching unit also makes provision for connecting two tape units simultaneously to the antenna digital control input circuits or the track digital control input circuits; one unit is designated as primary source and the other as the alternate source. The input circuits control both units but only the primary source sup-

plies data. Thus, the alternate source is kept in step with the other tape unit, and a source selector switch under control of the ground station control console permits the alternate tape to be selected to supply data if there is evidence of trouble with the primary source.

The tape switching unit also provides the facility for placing the data processors on line in the digital control system. In this operation, the output of the track digital control write circuits is delivered directly to the data processors as well as written on tape. The outputs of the data processors can be sent directly to either of the input circuits. One data processor serves as the primary source and the other as the alternate, and source selection may be used just as with tape units. These connections are used in the initial mode operation to be discussed in a later section.

X. STATION CLOCK

The station clock provides the basic time reference for the antenna pointing system. Its primary output is a digital representation of the hours, minutes, and seconds of Universal Time (UT_2) to a precision of $1/256$ second. This output is supplied to the antenna digital control and track digital input circuits for synchronizing the transfer of command data to the interpolators. The pointing operations are thereby synchronized with Universal Time. The time output is also supplied to the monitor and the track digital control write circuits for recording on the track tapes so that the position samples may be accurately correlated with Universal Time.

The heart of the station clock is a pair of crystal-controlled, temperature-stabilized oscillators operating in duplex at a frequency of 2^{23} cycles per second (8.388608 mc). These oscillators have a specified stability of better than 1 part in 10^9 per day (drift rates of 2 parts in 10^{10} per day have been measured). To permit the adjustment of these oscillators and to phase the output, the station clock produces a one pulse per second output which, after allowing for the transmission delay, is compared with the 1-pps VLF signal transmitted by NBA,¹⁰ Canal Zone. Using photographic oscilloscope techniques, the time output can be set with an accuracy of about 1 millisecond.

The station also supplies a number of time displays in the control room and lower room for operator convenience and an encoded time output for use on strip chart timing channels. Many submultiples of the oscillator frequency are supplied in the form of square waves to the other units in the digital control for local timing operations.

XI. OPERATING MODES

Now that the functions performed by the subsystems have been described, the operation of the digital equipment can be discussed. The tape switching features, the transfer selectors, and the command selector permit the system to be operated in a variety of configurations and modes. One form of the normal mode of operation is illustrated in Fig. 8. Prior to the start of the pass, two tape units containing identical mission tapes prepared by the data processors are assigned to the antenna digital control (ADC): one tape as primary and the other as alternate source. The ADC input circuits read the first block of data and, if it checks, store it in memory and begin to compare the tape time with real time. When a comparison is achieved, the command data are transferred to both the ephemeris and track interpolators by way of the transfer selectors. The interpolators begin producing the program commands at a 128 per second

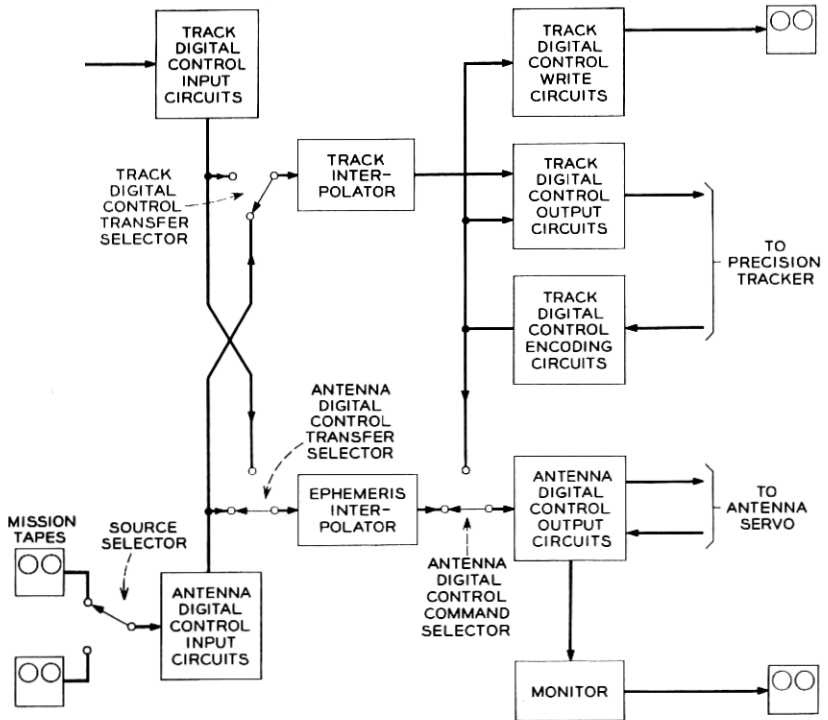

Fig. 8 — Normal mode operation block diagram.

rate and the output circuits cause the horn and precision tracker to come to the proper pointing angle.

At the predicted rise time of the satellite, incoming data points bring in velocity and acceleration commands that cause the horn and precision tracker to begin moving along the satellite's track. If the prediction and pointing accuracy is within $\pm 0.2^\circ$, as is usually the case, the autotrack and precision tracker acquire the microwave beacon within seconds after the satellite traveling-wave tube has been turned on by the command tracker. The communications connection is then established. Operation of the antenna servo may then proceed, with the control shared between the program commands and the autotrack; or the control may be placed entirely in the autotrack loop. Throughout the pass the track information is recorded on tapes by the monitor and the track digital control write circuits.

As the pass proceeds, the antenna digital control continues to process data blocks from the mission tape. After a good block is read, the other blocks of that data point are discarded. If a bad block is encountered, it is rejected and the next block inspected. If a number of data blocks are rejected, the ground station control console operator may decide, from observing the history of data point rejections displayed for that purpose, that the alternate source tape should be selected by actuating the source selector switch. Though no data were read from the alternate tape, the tape received control signals from the antenna digital control and was thereby kept in step with the primary tape and ready to assume the task of supplying data points.

If there appears to be difficulty in the ADC input circuits, the mission tapes may be switched by the tape switching unit to the track digital control input circuits and both transfer selectors switched so that the track digital control input circuits transfer the data to both interpolators. The advantage of using the ADC input circuits is that the precision tracker receives data that have been reasonably checked and that can be offset in time. It has the disadvantage that the track digital control (TDC) receives data that are predistorted with the horn compensation factors. However, these factors are small compared with the precision tracker beamwidth, and the function of the TDC is to provide only an acquisition track. Conversely, the use of the TDC input circuits to provide data to the ephemeris interpolator has the distinct disadvantages that no reasonableness checks are made, the time offset has no effect, and the data cannot be predistorted. This connection is used only in event of equipment failure.

Alternately, one might connect one mission tape to the ADC and the

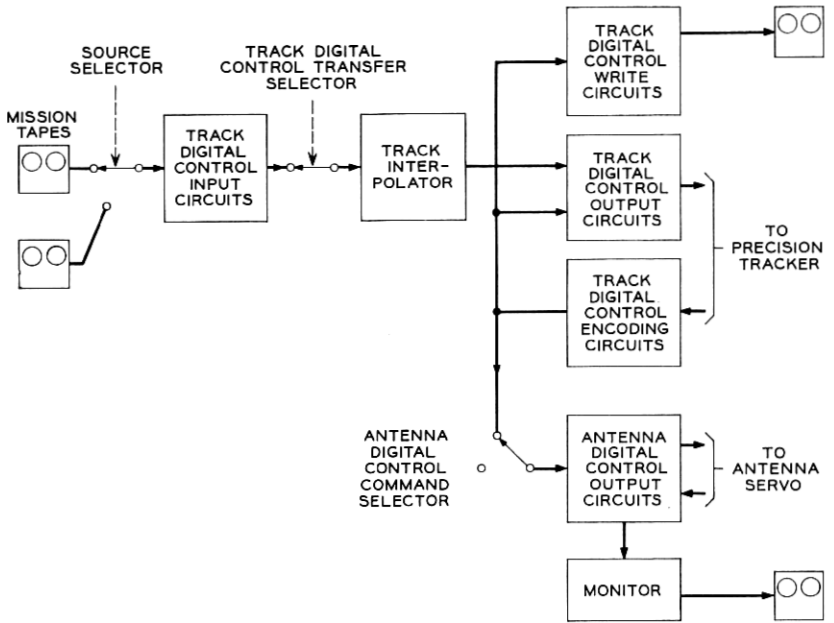

Fig. 9 — PT command mode operation block diagram.

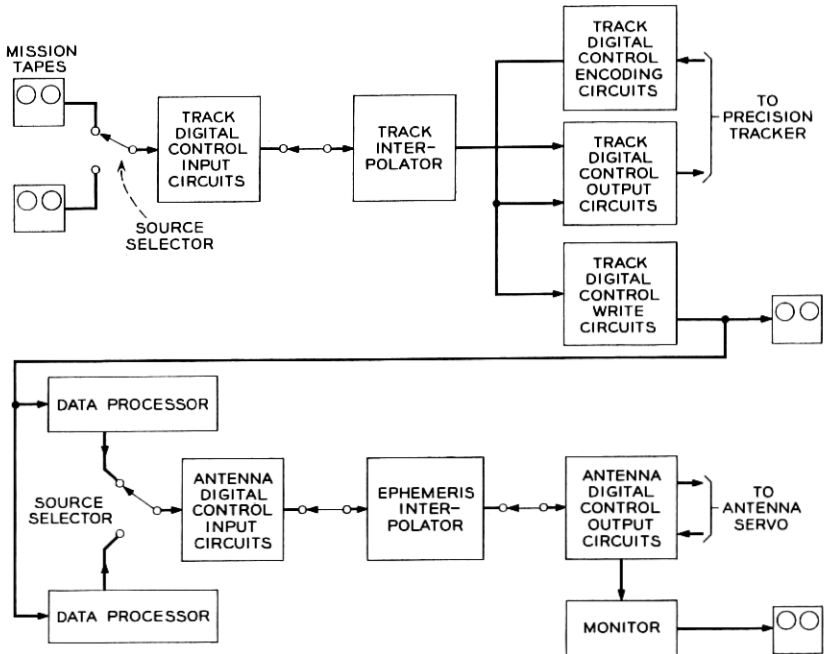

Fig. 10 — Initial mode operation block diagram.

other to the TDC. The ADC and TDC would then operate independently and, in event of failure of either input circuit, the equivalent of source selection could be achieved by use of the transfer selectors. This method of operation suffers from the fact that the source selection in the present equipment arrangement cannot be performed from the ground station control console.

In the above discussion it was assumed that the horn and precision tracker were tracking the same satellite. This is usually the case, especially in the present experimental system with only one satellite in orbit. With a number of satellites in orbit there may be frequent occasions when the antennas may track different satellites. This operation is possible and is the reason, of course, that two input circuits are provided.

When the satellite orbit is not accurately known, the system operation is somewhat different. A mission tape containing the best estimate of the pass is used to drive the TDC and point the precision tracker. The command tracker is slaved to the precision tracker by a synchro connection. The precision tracker and command tracker thus are pointed to the best available estimate of the satellite's position. The command tracker begins searching about this track with its 20° beam. When the command tracker acquires, the slave connection is reversed, bringing the precision tracker to the command tracker pointing angles and, after the command tracker has turned on the satellite, the precision tracker can acquire. The digital equipment provides two methods of slaving the horn antenna to the precision tracker so that the autotrack may acquire. The first of these is called the "PT command" mode and is illustrated in Fig. 9. In this mode the ADC command selector is switched to the PT command position and the output of the TDC encoding circuits, the precision tracker azimuth and elevation positions, is supplied as the commanded position input to the ADC output circuits. Thus, the precision tracker positions are supplied directly without smoothing, and the command positions are subject to the precision tracker tracking jitter. Also, no rate information is available to the antenna servo, and the horn antenna pointing is not compensated for distortion.

The second form of the slave mode, called the "initial mode," is designed to yield smoother performance. In this mode, which is illustrated in Fig. 10, the data processors are placed on line in the pointing operation. The output of the TDC write circuits feeds the two data processors as well as the usual tape unit through connections established in the tape switching unit. This input, consisting of time and position information twice a second, is read and smoothed by the data processors. This smoothed information is then used by the data processors as the basis

for a short-term prediction of the next data point. The data processors operate in duplex with the source selector providing the ground station control console operator with the facility of selecting the output of the secondary processor if his displays indicate that the primary processor is producing doubtful results. The output of the selected data processor drives the ADC input circuits through level-shifting circuits provided by the tape switching unit. The form of the data processor's output is identical to the data points normally recorded on the mission tapes and includes position, velocity, acceleration and range information and compensation factors. The ADC, in fact, operates as if it were reading a mission tape. Thus, the operation in this mode can be as smooth as that in the normal mode.

Throughout a PT command or initial mode pass, the monitor and TDC record the horn antenna and precision tracker tracks on tape in the usual manner. These recordings take on added significance in these slave-type modes because this track information can be used to refine the orbit prediction and permit the system operation to graduate to the normal mode on future passes.

XII. EQUIPMENT ASPECTS

The digital control is implemented using solid-state switching techniques for the most part. The majority of the functions are performed by transistor logic circuits. The digit rate required in performing most of the functions is a comfortably low 32 kc. For these speeds, a form of saturating transistor-resistor NOR logic (TRL) is used. In those few functions requiring significantly higher speeds, such as the encoding counting at 2 mc, a form of resistance-capacitor coupled transistor logic (RCTL) is used.

These circuits are mounted in multicircuit plug-in packages. A total of 29 different types of packages are used in the system to provide the various logic functions, cable drivers, and assorted circuit functions required. A typical logic package is shown in Fig. 11. The packages plug into mounting cages which can mount up to 20 packages. Subassemblies may use as many as four of these cages, or a total of 80 packages. The subassemblies are mounted in open-face racks with conventional back panel wiring. Subsystems may contain up to 5 racks. Interconnections between subassemblies within the same subsystem are made with open-wire runs, while interconnections between subsystems are made by coaxial cable. All wiring terminations, both those used in connecting components within the packages and those used in making the interconnections in the back

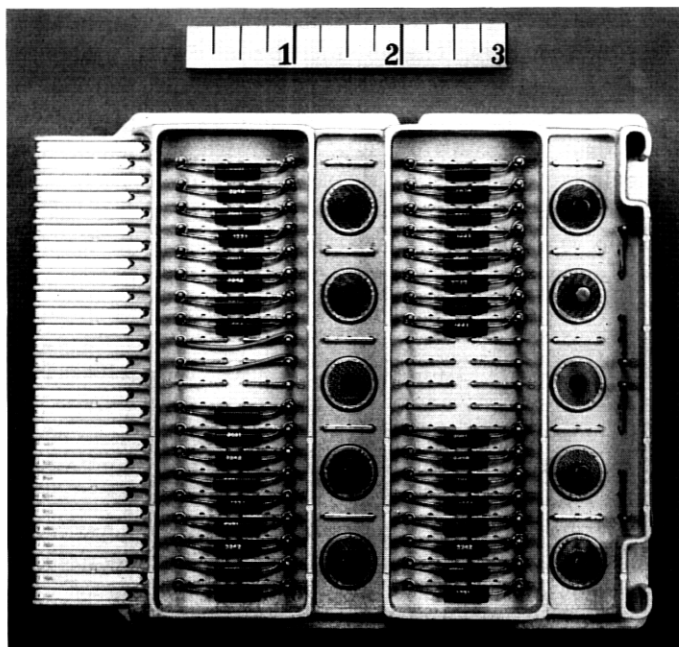

Fig. 11 — Logic package containing eight TRL gates.

panel wiring, are made with solderless-wrap connections for reliability. The racks contain an air ducting arrangement that allows cooling air to be blown over the transistors in each package in a subassembly. Auxiliary equipment, such as power supplies, is mounted in cabinets with swinging door access to both front and back.

With the bulk storage requirements met by magnetic tape units, the requirements for internal storage in the system are modest. Four magnetic core buffer memories are used in the tape read and write control units. These units each have a capacity of 144 characters. In addition, the antenna digital control and track digital control each use a 2048-bit magnetic core memory with sequential access for internal memory requirements.

The information within the digital equipment is handled in serial form, least significant bit first, with negative values represented by two's complement notation. While the use of binary is very convenient for the equipment, the interpretation of binary information by the operators would be difficult. The antenna digital control and track digital control perform the important function of converting the critical position in-

formation from binary to binary-coded-decimal and arranging for its display in decimal form. The antenna digital control provides for the simultaneous display of four two-axis positions selectively chosen from a total of 12 quantities that can be displayed. These quantities are displayed at the antenna control test position with a precision of six digits. Arrangements are made also to display three quantities on the ground station control console with a precision of five digits.

In addition to display functions, the antenna digital control also incorporates a number of features to permit operational control of the horn antenna from the ground station control console. This is not a simple function, because this console is located in the control room of the control building and is 1600 feet from the antenna. The same separation applies to the digital equipment, since the data processors, magnetic tape units, track digital control, station clock, and tape switching unit are in the control room, and the antenna digital control and monitor are in the lower room of the horn antenna. Information between the two areas must be transmitted 1600 feet and pass through the slip-ring assembly which brings all signals and power into and out of the antenna. In general, data signals are transmitted over 75-ohm coaxial cables, and manual control and indication signals are transmitted via a multiplex telegraph system, used to minimize the number of slip rings required. These considerations had considerable influence on the system design.

The dc power for the equipment is supplied by conventional commercially available 60-cycle rectifiers. Since during critical passes the 60-cycle prime power is supplied by diesel powered generators on the site, no precautions against intermittent power failures were taken except in the case of the power supply for the station clock. In this case, even a short power interruption at any time can upset the clock oscillator stability and, by disrupting the countdown process, change the time setting. Therefore, the clock power supply uses duplexed inverters, operating from independent 24-volt battery sources, which supply 60-cycle power to two sets of rectifiers. The outputs of these rectifiers are monitored by an automatic switching circuit which, in event of a failure of one source or one rectifier, switches the load without interruption to the other set of rectifiers. The clock oscillators and the clock countdown chain are thus protected from power failures. For the other parts of the digital control, each voltage also is supplied by two rectifiers which normally share the load but are capable of assuming the entire load. However, in this case, the switching of the loads to the good supply must be performed manually in the event of rectifier failure.

The station clock, track digital control, and tape switching unit oc-

cupy 8 racks, 8 cabinets, and a console in the control room. The antenna digital control and monitor utilize 8 racks and 2 cabinets in the antenna lower room. These racks and cabinets mount a total of 2085 packages and 1000 relays. The packages use over 11,000 transistors.

XIII. OPERATING EXPERIENCE

On the early passes following the July 10, 1962, launch of the satellite, acquisition was achieved using the PT command mode and tracking was performed in the autotrack mode. By the second day, the orbital elements had been refined sufficiently to permit autotrack acquisition from the pointing commands alone. Since that time, the normal mode of acquisition has been from the program command and the use of the precision tracker for acquisition generally has not been necessary. In tracking experiments, all conceivable variations of the acquisition and tracking modes were attempted and, in all cases, operation was satisfactory.¹¹

The smoothest tracking performance is achieved with the vernier autotrack in full control. In this mode the antenna follows the autotrack null with peak errors seldom exceeding 0.005° . With the control shared between the program command and the autotrack, these errors can reach 0.008° when the velocities are very low. The program-command-only mode yields tracking performance which meets the design objective. However, the high-quality performance of the autotrack has relegated the program-command-only mode to calibration and testing roles, such as star tracking and measuring the antenna patterns using the satellite.

The operating experience has shown the antenna pointing system to be a very flexible and accurate facility for satellite communications experiments. This operating experience also has demonstrated that the antenna pointing for an operational commercial satellite system can be much simpler and the role of the digital equipment greatly reduced. In such a system, the normal mode of operation would be full autotrack, and the digital equipment would provide acquisition only.

XIV. ACKNOWLEDGMENTS

A system of this size and complexity is not conceived, designed, fabricated and made operational in eighteen months without the full cooperation and extraordinary efforts of many people. The authors are indebted to all these people, and wish to acknowledge in particular the help of M. J. Gilmartin, E. Gomez, and W. T. Hartwell, who contributed heavily to the logical design; G. E. Saltus and W. L. Zweig, who struggled with the circuit problems; and H. Garber and J. O. Whyte, who handled

the equipment design and shepherded the equipment through fabrication, wiring, and installation.

REFERENCES

1. Githens, J. A., Kelly, H. P., Lozier, J. C., and Lundstrom, A. A., Antenna Pointing System: Organization and Performance, B.S.T.J., this issue, p. 1213.
2. Anders, J. V., Higgins, E. F., Murray, J. L., and Schaefer, F. J., The Precision Tracker, B.S.T.J., this issue, p. 1309.
3. Dolling, J. C., Blackmore, R. W., Kindermann, W. J., and Woodard, K. B., The Mechanical Design of the Horn-Reflector Antenna and Radome, B.S.-T.J., this issue, p. 1137.
4. Iwama, M., Norton, J. A., and Lozier, J. C., The Servo System for Antenna Positioning, B.S.T.J., this issue, p. 1253.
5. Claus, A. J., Blackman, R. B., Halline, E. G., and Ridgway, W. C., III, Orbit Determination and Prediction, and Computer Programs, B.S.T.J., this issue, p. 1357.
6. Cook, J. S. and Lowell, R., The Autotrack System, B.S.T.J., this issue, p. 1283.
7. Chapman, R. C., Jr., Critchlow, G. F., and Mann, H., Command and Telemetry Systems, B.S.T.J., this issue, p. 1027.
8. Westerman, H. R., Padgitt, R. D., and Penzias, A. A., Antenna Calibration with Radio Stars, to be published.
9. Kronacher, G., Design, Performance, and Application of the Vernier Resolver B.S.T.J., **36**, Nov., 1957, p. 1487.
10. Stone, R. R., Jr., Markowitz, W., and Hall, R. G., Time and Frequency Synchronization of Navy VLF Transmissions, I.R.E. Trans. Instr., **I-9**, No. 2, Sept. 1960, pp. 155-161.
11. Smith, D. H., Carlson, C. P., McCune, R. J., Elicker, R. E., and Sageman, R. E., Planning, Operation and External Communications of the Andover Earth Station, B.S.T.J., this issue, p. 1383.