

## PROJECT ECHO

# FM Demodulators with Negative Feedback

By CLYDE L. RUTHROFF

(Manuscript received March 22, 1961)

*The FM receiving demodulators used in the Echo experiment are described in this paper. These receivers have negative feedback applied to the local oscillator to reduce the FM modulation index in the receiver intermediate frequency amplifiers. This technique results in a threshold performance which is superior to that of a conventional FM receiver.*

### I. GENERAL

In the Project Echo communications experiment the path loss from the transmitter to the receiver via the satellite was very large. Even with reasonably large antennas, high power outputs, and low-noise receivers, the received signal was so small that a modulation technique was required that traded bandwidth for signal-to-noise ratio ( $S/N$ ).

For this experiment, wide-band frequency modulation was used, with receiving demodulators that were FM receivers with negative feedback (FMFB). The negative feedback results in an improved FM threshold and a resulting output  $S/N$  better than in other well-known techniques, such as single-sideband.\*

### II. SIGNAL-TO-NOISE RATIO AND THRESHOLD IN FMFB

A simplified block diagram of the FMFB demodulator<sup>1,2</sup> is shown in Fig. 1. As indicated in the figure, a part of the baseband (audio) output is used to frequency modulate the local voltage-controlled oscillator (VCO). The audio signal is phased in such a manner that the VCO frequency tends to follow the frequency variations of the RF input signal. The result is a reduction of the modulation index of the IF signal relative

\* Although this equipment was designed by the Bell System as part of its research and development program, it was operated in connection with Project Echo under Contract NASW-110 for the National Aeronautics and Space Administration.

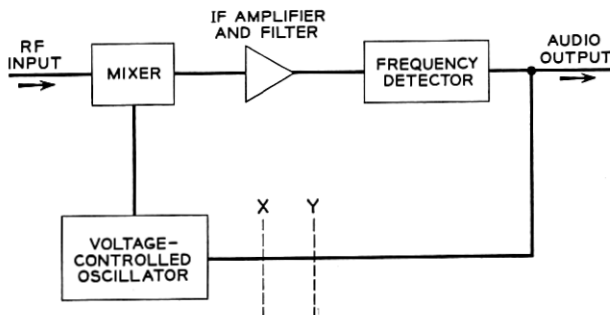

Fig. 1 — Simplified block diagram of FMFB system.

to the index of the RF signal and is, of course, negative feedback. If the RF index is  $M$ , the IF index is  $M/F$ , where  $F$  is the feedback factor. Since the IF index is small, the IF noise bandwidth can be made smaller than the RF bandwidth and an improvement in threshold can be expected relative to the threshold obtained using conventional FM in the same RF bandwidth.

There are two limitations on the IF filter. By a well-known approximation in FM work, the bandwidth required to transmit a baseband spectrum extending from 0 to  $f_b$  cycles per second is

$$B = 2f_b(1 + M), \quad (1)$$

where  $M = \Delta f/f_b$  is the FM index and  $\Delta f$  is the peak frequency deviation in cycles per second. It is clear that the minimum required bandwidth is  $2f_b$ ; hence the bandwidth of the IF filter in an FMFB receiver must be at least this wide. The second limitation on the IF filter has to do with the stability of the feedback loop.

For greatest threshold improvement the noise bandwidth of the filter should be small. This argues for steep skirts. Bode's stability criterion, on the other hand, limits the steepness of the skirts to a value not exceeding about 10 db per octave for practical receivers.<sup>3</sup> This criterion is necessary but not sufficient to insure stability when modulation is present.

A complete theoretical analysis of the threshold effects in the receiver has not been made as yet. However, there is strong theoretical and experimental evidence<sup>4</sup> that the  $C/N$  at which the threshold occurs is a function of the closed-loop bandwidth, the threshold occurring when the  $C/N$  in the integrated closed-loop bandwidth is about 6 db.

With reference to Fig. 1, the open-loop bandwidth can be measured by opening the loop between  $x$  and  $y$  and measuring the gain-frequency

response between  $x$  and  $y$ . The closed-loop bandwidth can be measured by measuring the gain-frequency response from the transmitter to the receiver output with the loop closed. For both of these measurements, low-level signals should be used. Fig. 2 indicates the type of results to be expected. The baseband analogs are shown, the actual IF characteristics being symmetrical about the IF carrier frequency.

The peak in the closed-loop response increases the noise bandwidth and is therefore undesirable. The height of the peak is dependent upon the steepness of the open-loop response and upon the phase shift in the circuit. Optimizing the threshold of this FMFB receiver is equivalent to designing the feedback network for minimum closed-loop noise bandwidth.

The performance of the FMFB receiver above the threshold can be understood with the aid of Fig. 1. When the feedback loop is opened at  $x$  the receiver is an ordinary FM receiver. Above the threshold the output signal-to-noise power ratio is

$$S_0/N_0 = 3 M^2(C/N), \quad (2)$$

where  $M$  is the modulation index and  $C/N$  is the carrier-to-noise power ratio at the input of the frequency detector, i.e., the noise power measured in a bandwidth of  $2f_b$ . The threshold for this case is described by Rice.<sup>5</sup>

When the loop is closed, the FM index in the IF is reduced by the

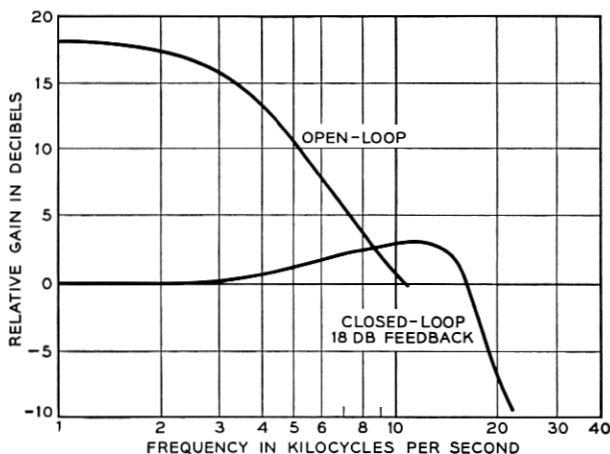

Fig. 2 — Open-loop and closed-loop response.

feedback factor  $F$ . This is true for both signal and noise, so that  $S_0/N_0$  remains unchanged. The index at the transmitter can now be increased by  $F$  to restore the original FM index in the IF; this increases the output  $S_0/N_0$  by the factor  $F^2$ .

It is evident then that at operation above the threshold the output  $S_0/N_0$  is given by (2), where  $M$  is the FM index at the transmitter. This is true for both FM and FMFB.

In summary, the signal-to-noise performance in FMFB is given by (2) above the threshold, and the threshold occurs at a  $C/N$  which depends upon the closed-loop bandwidth.

A word of caution is needed here. The foregoing statements have been made on the assumption that the feedback is large. For very small amounts of feedback, the threshold behavior approaches that of conventional FM.

### III. PROJECT ECHO RECEIVER

A complete block diagram of the receiver is shown in Fig. 3. The main feedback loop includes the mixer, 1.2-mc IF filter, preamplifier, limiter, discriminator, baseband filter, attenuator, and voltage-controlled oscillator. Another feedback loop includes the RF amplifier, mixer, 1.2-mc IF filter, preamplifier, and AGC detector-amplifier.

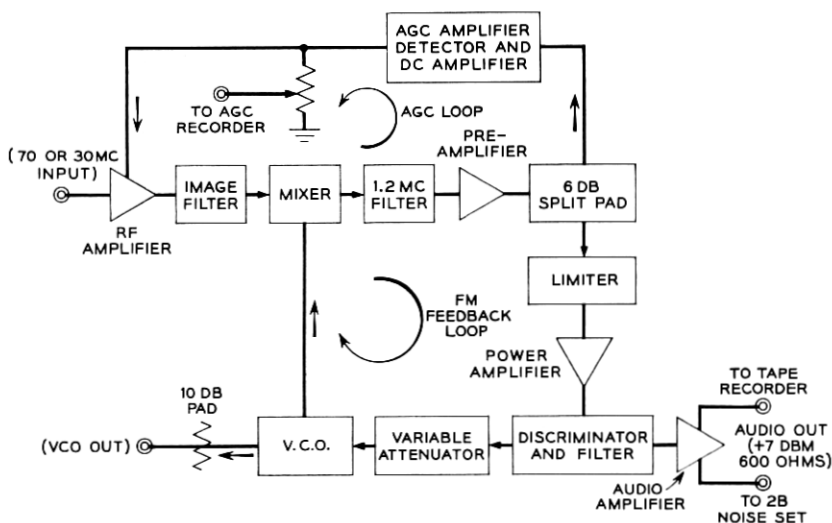

Fig. 3 — Block diagram of FMFB demodulator.

The purpose of the AGC is two-fold. The amount of FM feedback (i.e. loop gain) is proportional to the carrier level at the input of the discriminator. The AGC maintains this level constant and stabilizes the loop gain. Practical limiters are not good enough to do this, and, in fact, limiter input amplitude should be controlled for best limiting.<sup>6</sup>

The second purpose of the AGC is to provide a measure of the received carrier strength. The AGC voltage is calibrated in terms of known signal levels at the antenna input.<sup>7</sup>

Measurements of the performance of the receivers were made both in the laboratory and in the field. Fig. 4 is a measurement of audio  $S_0/N_0$  versus input  $C/N$  and shows the threshold. The  $C/N$  is referred to a 6-kc noise bandwidth. An image-rejection filter precedes the mixer, and the RF  $C/N$  is measured ahead of this filter.

The exact  $C/N$  at which the threshold occurs is somewhat arbitrary, since the knee of the curve is not sharp. However, in this receiver with the  $C/N$  above the threshold the circuit is very quiet. At the point marked "threshold" in Fig. 4 a cracking or popping sound begins. Chaffee<sup>1</sup> noted this effect, which sounds remarkably like the popping of corn. In this work, the threshold is assumed to occur when the popping starts. This effect, to the ear, is much more drastic than is indicated by the measured rms  $S_0/N_0$ . It is safe to say that at 1 db below this threshold the circuit is unusable in a realistic way, while just above the threshold the quality is excellent. A measurement of  $S_0/N_0$  versus  $C/N$  for the case where the feedback is zero (loop open) is included in Fig. 4. In this

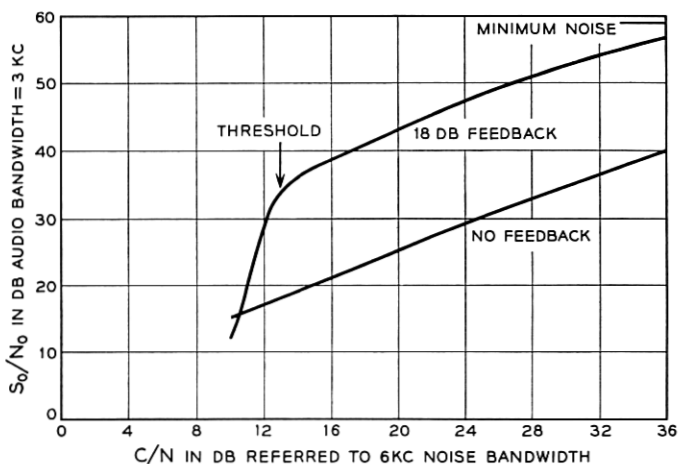

Fig. 4 — Threshold measurements.

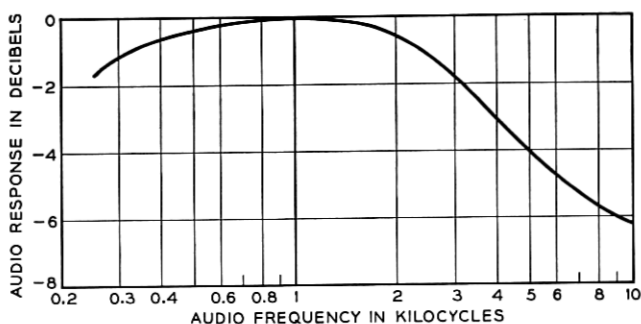

Fig. 5 — System audio response.

figure it is actually  $1/N_0$  that is plotted and referred to the signal output  $S_0$  obtained above the threshold. The threshold improvement of this receiver, compared to a conventional FM receiver using the same RF bandwidth, is about 9 db.

The audio frequency response of the receiver is given in Fig. 5, and is determined primarily by the filter in the audio amplifier.

During the operations,\* the receiving systems were tested by inserting known signals into the antennas and plotting the output  $S_0/N_0$  versus input carrier power. Fig. 6 is an example of such a calibration made at Goldstone. For this particular case the threshold occurred at  $-120$  dbm, and the feedback is approximately 23 db.

When the whole receiving system is involved, the accuracy of the threshold measurement is a function of the accuracy of the RF input signal level and the gain and noise temperature stability of the RF receiver. The  $-120$  dbm threshold quoted above, was often observed and is probably correct to within 2 db.

#### IV. CONSIDERATIONS IN FEEDBACK DESIGN

The minimum bandwidth required for a frequency-modulated signal is twice the bandwidth of the modulating signal. The IF filter in the FMFB receiver therefore has this bandwidth, i.e.,  $2f_b$ . As discussed previously, the maximum threshold improvement is obtained when the closed-loop bandwidth is a minimum for a given feedback factor. Any excess phase shift will increase the closed-loop bandwidth and is therefore undesirable.

\* These experiments were in connection with National Aeronautics and Space Administration Contract NASW-110.

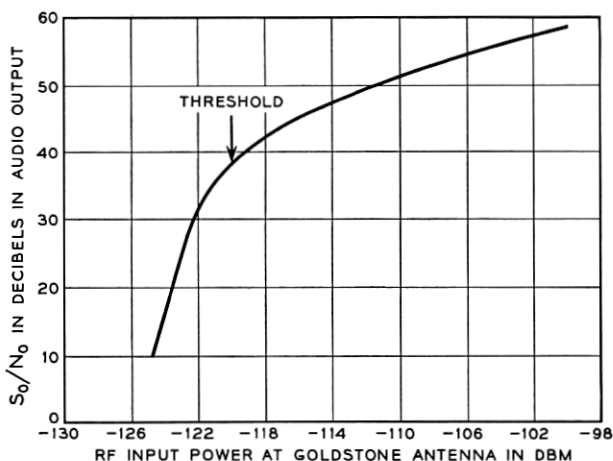

Fig. 6 — Demodulator calibration at Goldstone, August 11, 1960.

In the Echo receivers, all circuits were made extremely broad to minimize excess phase, and the shaping was done in the IF filter. There are several important factors which warrant discussion.

#### 4.1 IF Frequency

The output of the broadband discriminator is largely carrier power. This cannot be allowed to reach the VCO so a filter is required to reduce the carrier and its harmonics and allow the baseband through with the least possible phase shift. Therefore the IF frequency should be as high as possible. The upper limit is determined by the circuit  $Q$  obtainable for the IF filter. Coil  $Q$ 's in the megacycle region are limited to 400 to 500, so an IF frequency of 1.2 mc was chosen requiring loaded  $Q$ 's of approximately  $1200 \text{ kc}/6 \text{ kc} = 200$ . The corresponding baseband filter is  $M$ -derived with a cutoff frequency of 1 mc.

#### 4.2 Discriminator

This is a balanced circuit with a single-ended output. No filtering is used on the output side of the diodes other than the baseband filter. The usual filtering with capacitors would increase the output but would introduce excess phase shift. The balanced property provides some limiting in the absence of modulation.

### 4.3 Limiter

Limiters contain reactive elements and therefore add to the excess phase. For this reason, multistage limiters were avoided and a single-stage limiter was used. For best results, this limiter requires a controlled input level;<sup>6</sup> hence the AGC operates to fix the level at the limiter input.

### V. ACKNOWLEDGMENTS

The author is indebted to W. F. Bodtmann, Jr., for much of the equipment design, testing, and operation of the receivers. Noteworthy contributions were also made by J. P. Schafer, H. E. Keller, F. A. Dunn, and L. H. Enloe.

### REFERENCES

1. Chaffee, J. G., Application of Negative Feedback to Frequency Modulation Systems, *B.S.T.J.*, **18**, 1939, p. 404.
2. Carson, J. R., Frequency Modulation—Theory of the Feedback Receiving Circuit, *B.S.T.J.*, **18**, 1939, p. 395.
3. Bode, H. W., *Network Analysis and Feedback Amplifier Design*, D. Van Nostrand Co., New York, 1945.
4. Enloe, L. H., to be published.
5. Rice, S. O., Properties of a Sine Wave Plus Random Noise, *B.S.T.J.*, **27**, 1948, p. 109.
6. Ruthroff, C. L., Amplitude Modulation Suppression in FM Systems, *B.S.T.J.*, **38**, 1958, p. 1023.
7. Ohm, E. A., Receiving System, this issue, p. 1065.