

A Loss and Phase Set for Measuring Transistor Parameters and Two-Port Networks Between 5 and 250 mc*

By D. LEED and O. KUMMER

(Manuscript received September 14, 1960)

An insertion loss and phase measuring set has been developed for making small-signal measurements on transistors and general two-port networks with maximum inaccuracy of 0.1 db and 0.5 degree over a frequency range from 5 to 250 mc. In order to realize accuracy substantially independent of test frequency, the measurement information is heterodyned to a fixed intermediate frequency, where detection is performed with the aid of adjustable loss and phase-shift standards. Use of a rapid sampling technique to compare the unknown with a high-frequency standard eliminates errors from circuit drifts and also reduces the magnitude of the "instrument-zero line" to a small value. Besides discussing the over-all operation of the new test set, the paper presents the design approaches used in solving problems related to purity of terminations as seen from the unknown, automatic control of beat oscillator frequency, conversion, signal-to-noise, and design of loss and phase standards. Particular attention is given to the features of the set which especially adapt it to the measurement of transistor parameters.

I. INTRODUCTION

In the early stages of development of specific transistor types, compromise performance targets are worked out that are both desirable from a circuit use standpoint and feasible from a fabrication viewpoint. Fairly simple electrical measuring instruments are sufficient to guide the development during this early period. However, past performance has shown that the device designer converges rather rapidly on the agreed-upon targets, and device reproducibility quickly reaches a point where

* This work was supported in part by Task V of Joint Military Services Contract DA-36-039 sc-64618.

more precise knowledge of the device characteristics would permit greater sophistication in circuit applications. At this point, accurate measurements must be made of the frequency characteristics of the device and of the circuits in which it is used, in order to sustain further progress in circuitry development. This paper is concerned with an instrument designed to meet such measurement needs in the frequency range from 5 to 250 mc.

The first portion of the paper reviews the special problems involved in making accurate broadband measurements on transistors. It is noted that the chief limitation stems from the difficulty of providing a known circuit environment around the unit under test. At high frequencies, this problem is aggravated by selecting excessively large or excessively small termination impedances. For this reason, an impedance level of 50 ohms has been chosen for both source and load in the measurement apparatus that is described. The data required for completely characterizing a transistor on a two-port basis are obtained by making four independent insertion loss and phase measurements, with the transistor inserted in four different configurations in relation to the 50-ohm terminations. General two-port networks may be measured as well as transistors.

Section II summarizes the basic measurement method and indicates measurement accuracies and ranges. This is followed by a discussion of the transformations from the measurement parameters to other matrix sets used in design and analysis. This section also lists the principal objectives, other than those related to accuracy, that specifically influenced the measurement set design. Chief among these were the demands for small-signal measurements, for built-in facilities for expediting measurements on transistors, and for a considerable amount of automatic operation to promote ease-of-use and minimize operator error.

Sections III and IV describe the measuring circuit in progressively finer detail, starting from a block diagram description. Questions relating to both system and circuit design are discussed, together with the approaches used in solution.

Section V deals with the aspects of the set which especially adapt it to transistor measurement. This includes the technique for bringing a 50-ohm measurement plane up to the base of the transistor header and the method of biasing the transistor without introducing signal path reflections.

Equipment design considerations are covered in Section VI, with special emphasis on the features for relieving the amount of manual operator labor during long runs of measurements.

Tests made to validate the measurement accuracy are considered in

Section VII. Special self-calibrating procedures are described for absorbing secondary sources of test error.

Measurement results are presented in Section VIII, showing the method of obtaining an h -parameter characterization for a broadband diffused-base transistor.

1.1 *Optimum Two-Port Measurement Parameters for Transistors*

The principal source of inaccuracy in measuring impedances or transmission quantities at high frequencies stems from the difficulty of providing a known circuit environment around the object under test. Unlike the problem of providing adequate loss or phase standards, which may be relieved by heterodyning the measurement information to a constant detection frequency, there is no evasive solution to the termination control question. This problem is not relieved by the introduction of a converter; it must be dealt with directly at the frequency of test signal applied to the unknown.

There are several reasons why the provision of well-defined source and load terminations becomes more difficult in transistor measurements. First of all, the transistors intended for circuit uses in the VHF range are not, at present, coaxially encapsulated. As a result, a "jig" is necessary for making the transition from the noncoaxial basing of the transistor to the usual coaxial geometry of the ports of the measurement set. Since the residual parameters of the jig contribute to the circuit environment around the transistor, it is necessary to produce either a jig whose parasitic elements are insignificant, or one whose parasitic elements are evaluable.

Another unique difficulty in providing known terminations during transistor measurement arises from the need to energize the device with dc in order to make it active. Unavoidably, the circuitry used to connect biasing currents and voltages to the transistor tends also to introduce impedance and transmission vagaries in the signal path.

At low frequencies, ac residuals due to jigs and to dc activation are generally negligible, and this makes it possible to realize a wide gamut of known termination impedances. "Shorts" and "opens" can be closely approximated, so that h , y , or z parameter sets may be measured directly. However, at high frequencies, the range of attainable sources and receiver impedances is limited by the residual parameters of the jig and bias connection circuitry, and by the extreme difficulty of realizing broadband open- and short-circuit impedances.

The measurement set described in the present paper deals with the

high-frequency termination problem by recognizing that attempts to realize the extreme impedances required for direct measurement of h , y , or z parameters would not prove fruitful. Instead, the design effort was aimed at synthesizing a 50-ohm termination level. At this impedance level, stray reactances that would ordinarily make the realization of very large or very small impedances impracticable can be compensated so that they produce only small reflections.

With 50 ohms established as the source and load impedance, a set of four measurements completely characterizes the transistor at each frequency of test. This set of measurements consists of the insertion loss and phase in each direction of transmission through the transistor, and the insertion loss and phase due to bridging each of the transistor ports across the 50-ohm signal path. During the bridging measurements the remote port is terminated in 50 ohms. These four measurements are closely related to the set of finite termination parameters defined by I.R.E. Standards.¹ They may be transformed to any of the other two-port characterization frameworks or to equivalent circuit representations.

1.2 *Interest in Two-Port Measurements*

A measuring instrument which yields sufficient data to characterize active devices completely is equally useful for characterizing general two-port networks. This is an important consideration, since the circuit designer not only needs to characterize devices from a circuit-use standpoint but also must assess the performance of complete circuits using these devices.

Indeed, the need for the most precise measurement ordinarily occurs in the design of "analog-type" communication systems, such as L3 carrier² or the TD-2 microwave relay system.³ These cases demand the highest accuracy because of the opportunity for systematic pile-up of distortion through long chains of tandem-connected apparatus. For this reason, highly accurate laboratory instrumentation is needed for measuring loss, phase, and impedance of linear two-ports, so that effectual steps may be taken to solve the equalization problem during the laboratory phase of the system design.

In the development of regenerative PCM systems, the accuracy called for in measuring frequency characteristics is generally less stringent than that required for analog systems. The relaxation of accuracy tolerances is possible because of the absence of frequency distortion pile-up through successive repeaters. However, it is still desirable to supplement heavily used time-domain measurement procedures with frequency-characteristic measurements on the essentially linear parts of such systems.

II. MEASUREMENT PRINCIPLES AND PERFORMANCE

2.1 Method of Measurement

The basic quantities measured are insertion loss and phase shift; the general method of measurement is illustrated in Fig. 1(a).

Vibrating relays s_1 and s_2 sequentially interpose the unknown and a coaxial strap between a 50-ohm source and load. The interchange is made 60 times a second. During the time interval when the path is completed through the strap, the instrument essentially measures the amplitude of the output voltage, $|E_s|$, and stores the measured value. When the path through x is completed, $|E_x|$ is measured and stored. The differ-

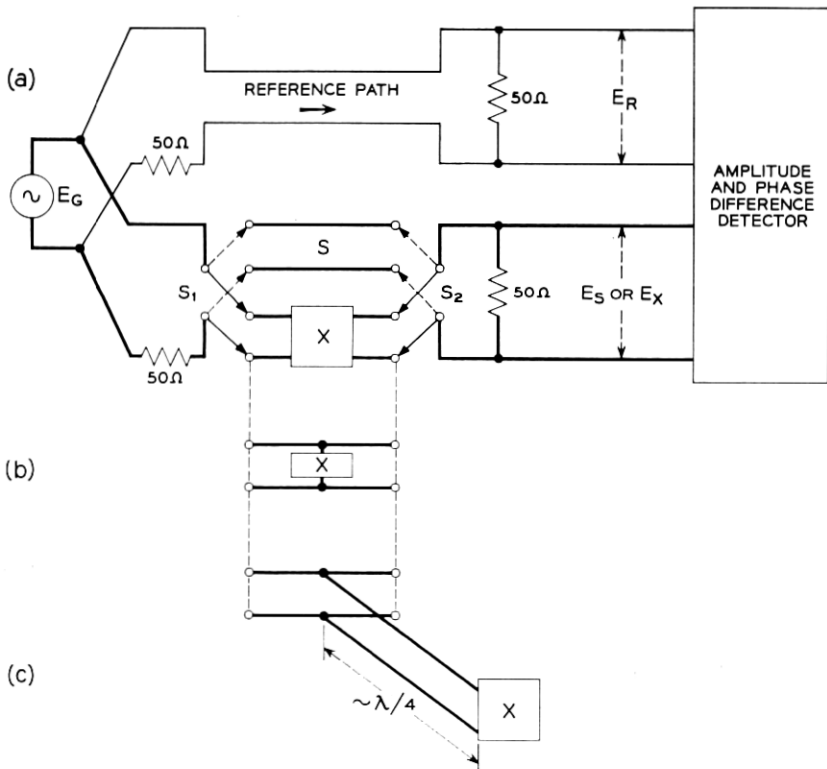

Fig. 1 — (a) Rapid comparison principle of measurement: alternatively interposing X and S between generator and load prevents errors from variations of generator level, detection sensitivity, or shift of detector operating point. (b) Impedance measurement by bridging. (c) Inversion of high impedance by $\lambda/4$ line transformer.

ence between the two stored values is read out on a null balanced attenuator standard as the insertion loss,

$$20 \log_{10} \left| \frac{E_s}{E_x} \right|.$$

Insertion phase shift is the difference of phase between E_s and E_x . Since E_s and E_x appear in time sequence, their phase difference may not be obtained directly. Instead, each of these two signals must be phase-compared in succession with the constant output, E_R , from a supplementary reference path. First, the phase difference between E_s and E_R is measured and stored; this is followed by measurement and storage of the phase angle between E_x and E_R . The insertion phase shift is just the difference between the two successive phase measurements, and this difference is read out on a null-balanced calibrated phase shifter.

The comparison of s with x is so rapid that the measurement results are unaffected by slow wanders of source level or by drifts of detector operating point or of gain. This arrangement also obviates error from shifts in source level or detection sensitivity with frequency, since the source and detector are the same for both s and x. To prevent errors in the comparison of the unknown with the standard, the transmission paths through the switch must be well matched to the nominal termination level, the two paths must transmit equally, and the crosstalk from the open to the transmitting path must be small.

Impedance values may be inferred by measuring the insertion loss and phase caused by bridging the unknown impedance across the x path, as suggested in Fig. 1(b). If the measurement yields an insertion loss and phase factor, $e^{\alpha+j\beta}$, where α is the insertion loss in nepers and β is the insertion phase shift in radians, then the impedance, Z , is computable from the relationship

$$W = e^{\alpha+j\beta} = 1 + \frac{1}{2} \left(\frac{50}{Z} \right). \quad (1)$$

A chart technique has been worked out for graphically converting from W to Z , based on the fact that the two are bilinearly related. The bilinear relation simplifies the mapping problem, because circular loci in the W plane transform to circular loci in the Z plane. Chart designs of this type are covered in earlier work.⁴

Impedance measurement sensitivity decays rapidly as $|Z|$ increases; a resistor of 25 ohms causes 6 db loss, but the loss for 100 ohms is only 2 db. The drop in insertion loss decreases measuring accuracy. Consequently, high impedances are initially transformed to lower values by the use of a quarter-wave coaxial line transformer, as shown in Fig. 1(c).

The transformer consists of a 39-foot length of 50-ohm air dielectric coaxial line, and is therefore useful as an impedance inverter only in the vicinity of odd multiples of 5 mc. The need for *a priori* knowledge of the constants of the line may be avoided by the self-calibrating technique of measurement described later in Section 7.3. This technique also removes the necessity for adjusting the signal frequency so that the line is an exact odd multiple of quarter wave length.

2.2 Measurement Accuracy and Ranges

Signal Source. 5 to 250 mc in two bands; ± 3 per cent scale calibration accuracy. The stability and precision of setting are sufficient for adjusting to specifically desired frequencies with a tolerance exceeding 10 kc, using high-accuracy commercial counters for frequency measurement.

Source and Load Terminations. 50 ohms for transistor measurement; 50 or 75 ohms for coaxially terminated networks.

Insertion Loss. Range: 60 db loss to 30 db gain. Accuracy: ± 0.1 db from 30 db gain to 40 db loss; ± 0.3 db from 40 db to 60 db loss.

Insertion Phase. Range: 360 degrees. Accuracy: ± 0.5 degree from 30 db gain to 40 db loss; ± 1.5 degrees from 40 to 60 db loss.

These accuracies apply to the measurement of coaxially terminated networks whose image impedances are well matched to either the 50- or 75-ohm termination levels. Further error results from interaction between the impedances of the unknown and the residual impurity of the terminations. Mismatch errors are estimated in Section 7.2 for the case of passive, reciprocal unknowns.

The listing of return losses in Table I is based on measurements made directly at the test set ports into which the unknown is plugged.

TABLE I

Frequency up to	Return Loss Relative to 50 Ohms, in db	
	Source Termination	Load Termination
Transistor Measurements		
100 mc	>35	>31
200 mc	>30	>25
250 mc	>28	>25
General Two-Port Measurements (50 Ohms)		
100 mc	>35	>35
200 mc	>30	>30
250 mc	>28	>28

These data show that the reflections from the jig and biasing circuitry are quite small, as evidenced by the fact that return losses for transistor measurement are at most 5 db poorer than for coaxially terminated unknowns. The design of the elements that determine the return losses presented during transistor measurement is discussed in Section V.

2.3 Relationship of Measured Quantities to Other Two-Port Descriptions

Transistors are characterized by making the following four measurements:

(a) Insertion loss and phase shift in both directions of transmission between 50-ohm impedances.

(b) Insertion loss and phase shift obtained when first one port of the unknown and then the other is bridged across the 50-ohm transmission path. The remote port of the transistor is terminated in 50 ohms during these bridging measurements.

If the index number 1 is assigned to one of the ports of the unknown and 2 to the other, then the two measurements of (a) yield the data $e^{\varphi_{12}}$ and $e^{\varphi_{21}}$, and (b) yields $e^{\varphi_{11}}$ and $e^{\varphi_{22}}$. These four parameters define a matrix set, P , which completely characterizes the device under test:

$$P = \begin{pmatrix} e^{\varphi_{11}} & e^{\varphi_{12}} \\ e^{\varphi_{21}} & e^{\varphi_{22}} \end{pmatrix}.$$

P may be transformed to the finite termination parameter matrix by replacing $e^{\varphi_{11}}$ and $e^{\varphi_{22}}$ with the corresponding impedance values computed from (1) in Section 2.1.

The conversion to the scattering matrix, using the appropriate termination resistance as normalizing number, i.e. 50 or 75 ohms, is relatively direct. Defining the scattering matrix S in the conventional way,

$$S = \begin{pmatrix} s_{11} & s_{12} \\ s_{21} & s_{22} \end{pmatrix},$$

it is shown in Appendix A that the coefficients of P and S are related such that

$$s_{11} = \frac{3 - 2e^{\varphi_{11}}}{-1 + 2e^{\varphi_{11}}},$$

$$s_{12} = e^{-\varphi_{21}},$$

$$s_{21} = e^{-\varphi_{12}},$$

$$s_{22} = \frac{3 - 2e^{\varphi_{22}}}{-1 + 2e^{\varphi_{22}}}.$$

The relation of the elements of P to those of the h , y , and z matrices is obtainable from previous work.⁴

2.4 Objectives

A number of objectives influenced the design of the measurement set, other than those relating specifically to accuracies and ranges of the measured quantities.

The broadest object was to provide a measuring facility capable of completely characterizing either passive or active linear two-ports. This was accomplished by incorporating bridging loss as well as insertion loss measurement features.

Secondly, the instrument was to aid in studying small-signal parameters of transistors and their variation with shift of dc operating point. To make such measurements possible, unknowns are excited very lightly in relation to bias power magnitudes. For example, in measuring between 30 db gain and 19.9 db loss, the power delivered to the input port is always less than -30 dbm. The light drive, when combined with transistor loss, decreases the signal voltage available for detection. Consequently, signal-to-noise questions were dominant in the instrument design.

Finally, it was recognized that a great many measurements would be necessary to adequately characterize an unknown over the full 5 to 250 mc frequency range. For this reason, the design aimed at cutting down, to a reasonable minimum, the amount of decision making, knob manipulation, patching changes, and other operator activities required for obtaining measurement answers. This not only has the effect of speeding up the measurements, but also reduces the chances for human error. A high price was paid in the form of "behind-the-panel" complexity to partially substitute machine logic, machine programming, and mechanisms for operator thought and motor activity.

III. DESIGN OF THE MEASURING SET

3.1 Introduction

The development work naturally divided into two parts: the development of an insertion loss and phase measurement set covering the 5 to 250 mc range, and the development of jig, auxiliary fixtures, biasing facilities, and programming arrangements to adapt the basic set to transistor measurement.

In order to obtain measurement accuracy substantially independent of frequency over the $5\frac{1}{2}$ -octave range of test signal, it was necessary to

heterodyne the measurement information to a fixed intermediate frequency, where detection was actually performed with the aid of precisely calibrated loss and phase shift standards. This not only relieved the problem of standards design, but also provided the opportunity to reduce thermal and tube noise by use of a narrow intermediate frequency bandwidth. The improvement in signal-to-noise ratio was an important factor because of the low level of transistor excitation. On the debit side, the narrow IF band made it necessary to control the frequency of the beat oscillator automatically, because the required precision in the setting of the intermediate frequency could not reasonably be obtained by manual tuning.

Besides possible error due to mistermination, the test set is subject to errors from miscalibration of standards, crosstalk, and noise. The contribution from crosstalk and noise is closely tied up with the heterodyne aspect of the instrument design, and it is of interest to examine these error sources briefly, before proceeding with further details.

The heterodyne outline of the set is shown in Fig. 2 stripped of the rapid comparison and null-balancing features. It will be noted that a crosstalk path exists for spurious transmission of signal frequency, F , from the reference path to the unknown path via the common beat oscillator connection, and vice versa. The damage done by this unwanted

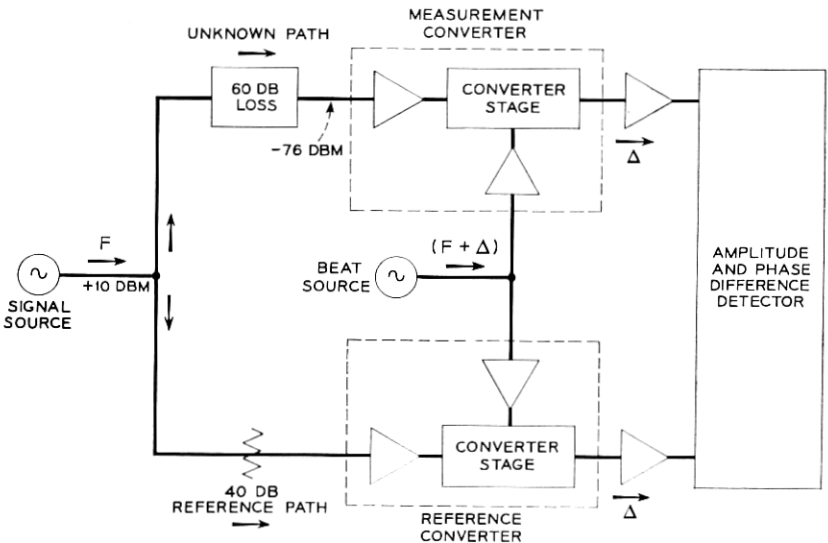

Fig. 2 — Heterodyne framework of test set at 60-dB loss level.

transmission is a function of the unknown's loss. In the present set, the input level to the measurement converter is -76 dbm when measuring at the maximum loss level of 60 db. As a result, any stray component of frequency F , equivalent in its effect to a signal of -116 dbm at the measurement converter input, could lead to maximum errors of 0.1 db or 0.5 degree, depending on the phase of the spurious signal. In addition to crosstalk, leak from the signal oscillator to low-level points in the signal paths is an equally potent source of error.

These potential sources of inaccuracy were controlled in a number of ways. First of all, buffer amplifiers were introduced in the signal and beat frequency channels preceding the conversion stages in each converter. All RF and IF circuitry was carefully shielded to guard against radiation and air path couplings. It was also helpful to reduce the maximum possible level difference between signal inputs to the two converters by adding a 40-db loss pad in the reference path. The object of these efforts was to keep errors from crosstalk and pick-up below 0.1 db when measuring 60-db loss.

Similarly, a 0.1-db limit was established on error due to noise at 60-db loss level. Study showed that this objective could be met by relatively straightforward approaches to converter, IF amplifier, and detector design. In fact, with a 20 kc IF bandwidth and simple linear detection, a converter noise figure of 30 db proved tolerable. The relatively lenient demand on noise figure made it possible to use a vacuum tube conversion stage, operating in a square law mode, with the attendant low power requirement on beat oscillator drive. Moreover, the modest noise figure could be realized without introducing gain in the buffer circuitry preceding the conversion stages. The design of the over-all converter is covered in Section 4.3.

The noise created by IF circuitry is small compared to the contribution of the converter.

3.1.1 *Loss Measurement*

The measurement system is shown in block form in Fig. 3 for the case of 50-ohm insertion loss and phase measurements. The basic source is a signal oscillator, tuning from 5 to 250 mc. It delivers energy through a 50-ohm transmission path to a pair of vibrating relays that sequentially interpose the unknown and a standard between the signal source and measurement converter. A pair of solenoid-operated coaxial switches allows any one of three unknown paths to be selected, depending upon whether 50-ohm, 75-ohm or transistor measurements are to be made.

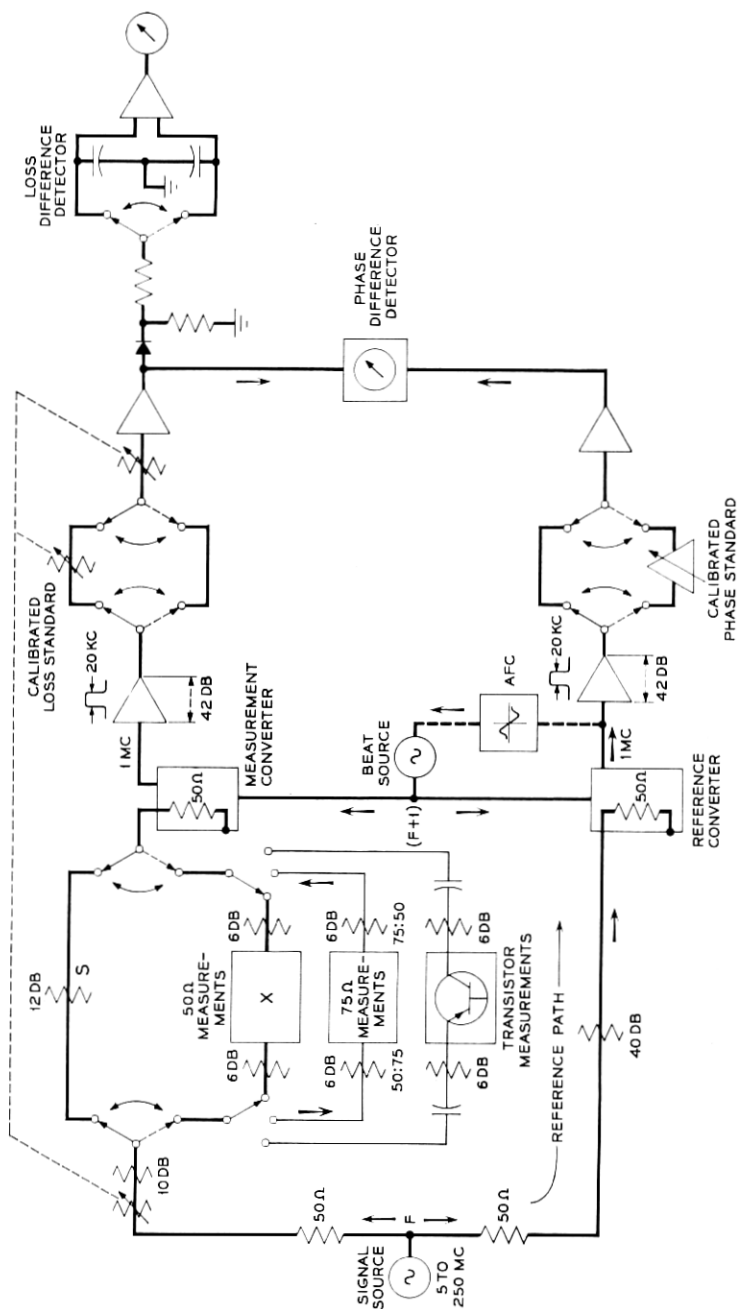

Fig. 3 — Block diagram of measurement set. Parameters of unknown are heterodyned to a constant detection frequency, where their magnitudes are read out on null-balanced, calibrated loss and phase standards.

To reduce the frequency of taking "zeroes," the electrical lengths of the three unknown paths have been adjusted to equal the length of the standard path. Over the full 250 mc frequency range, the instrument "zero-line" is less than 0.1 db and 2 degrees for all three measurement modes.

An auxiliary oscillator, operating always one megacycle higher in frequency than the signal oscillator, beats the measurement information down to a fixed 1 mc intermediate frequency. In the interest of obtaining maximum S/N ratio at the detection point, the IF bandwidth was made as narrow as possible without, at the same time, imposing unreasonably severe tolerances on the settability or frequency stability of the continuously tuned source and beat oscillators. A bandwidth of 20 kc was chosen; the band shaping is introduced by the IF amplifier following the converter. After passing through the amplifier, the signal proceeds through another vibrating relay path and ends up finally at an amplitude-sensing detector.

The relays provide the means for rapidly comparing the transmission of the unknown and standard paths. All moving contacts are synchronized at a 60-cycle rate. When the upper paths are closed, as indicated in the figure, the circuit is completed through the standard channel at both test-signal and intermediate frequencies. The detector then measures the level it receives and stores the measured value in the form of a voltage across a capacitor. When the lower path is completed, the unknown is energized, and the detector measures and stores the transmission through the unknown path on a second capacitor. Using the indication of the difference between the two items of stored data as presented on the magnitude meter, the operator adjusts the loss standard for a null. At the null point, the loss of the unknown must exactly equal the loss in the calibrated attenuation standard, provided the converter accurately transposes changes of level from the signal to the intermediate frequency. The converters are so lightly excited that the nonlinearity errors are less than 0.05 db over the full range of loss measurement.

In order to minimize the dynamic range over which the loss detector must operate, common-path attenuation is ganged to the loss standard in such a way that the sum of the common-path attenuation plus that of the standard is approximately constant. Consequently, any variation of detector input level with change of test frequency occurring at the point of null balance must be due only to the frequency characteristic of conversion loss. The conversion loss does increase about 8 db between 50 and 250 mc, but this droop is prevented from introducing a sensitivity variation by an AGC circuit located in the detector.

In measuring at the higher losses, a greater portion of the common-path attenuation is assigned to the attenuator section located at intermediate frequency. Although this does have the somewhat undesirable effect of increasing the signal drive on transistors when measuring at high loss, it prevents the input level to the converter from dropping dangerously close to noise. The way in which the pattern of attenuation is worked out assures sufficient signal for an S/N ratio* of 22 db at the detection point during 60-db loss measurements at 5 mc. At 250 mc, the S/N ratio is only 14 db when measuring 60-db loss, but, even under these circumstances, the error contribution due to noise is less than 0.1 db. These matters are discussed more fully in Section 4.2.1.

Increasing the level at the unknown in proportion to its loss has the further desirable effect of reducing the dynamic range of the signal applied to the converter. The total transmission measurement range of 90 db (60 db loss to 30 db gain) subjects the converter to an input level change of only 60 db.

When making gain measurements, the loss standard is inserted in series with the unknown, by transposing it from the s to the x channel. The necessary changes in the common attenuation ganging are made automatically at the same time.

3.1.2 *Phase Measurement*

The technique of phase measurement is analogous to that of loss measurement. The output from the reference converter provides a 1-mc phase-reference signal. During the period when the upper path is completed through all the relays, the phase detector measures and stores the value of the phase difference between the outputs of the standard and reference paths. When the relays change state, the detector makes another measurement of the phase difference between the output of the unknown path and the output of the reference path as modified by the calibrated phase standard. The difference between these two stored measurements, which is displayed continuously on the phase-indicating meter, is adjusted to zero by operating the phase standard for a null. At the null point, the phase shift through the standard exactly offsets the high-frequency phase shift through the unknown.

3.2 *Attributes of the Measurement System*

The measurement circuit combines features of rapid comparison and null balancing of standards with heterodyne detection.

* S/N ratio, as used in this paper, refers to the quotient of rms carrier voltage to rms noise voltage in the 20-kc IF bandwidth.

Use of rapid comparison and null balancing makes the measured data depend solely on the difference between the properties of the unknown and standard. Drift of source level, or gain and phase drift in the IF amplifiers and detectors cause no error, as long as the drift is small over the $\frac{1}{\sigma}$ second interval required to complete the comparison between the unknown and standard. Also, the rapid comparison feature greatly relieves requirements on tracking of conversion phase and loss between the two converters, since the converters, too, are common to the channels being compared.

The heterodyne technique has several conspicuous advantages. First of all, locating the loss and phase standards at the intermediate frequency avoids the problem of developing broadband standards. It would be especially difficult to design and construct a variable phase standard with an accuracy of 0.2 degree that had a frequency-insensitive calibration between 5 and 250 mc.

Secondly, noise power is reduced before detection by the narrow band IF amplifiers; so error of measurement due to system noise is reduced. This question is dealt with quantitatively in Section 4.2.1.

Furthermore, the heterodyning permits loss of the unknown to be made up by single-frequency gain at the intermediate frequency. This is advantageous, since a large amount of relatively flat broadband gain is difficult to provide.

Finally, the heterodyne system introduces the advantage of selective detection. It provides immunity from errors due to harmonics and stray signals in the output of the unknown.

IV. SUBSYSTEMS OF THE MEASUREMENT SET

4.1 *Automatic Frequency Control of Beat Oscillator*

The heterodyne technique of measurement introduces the need for a tunable beat oscillator to translate measurement information to the 1 mc IF. The starting point for the design of the beat source involves the requirements on settability of its frequency and this, in turn, is based on the allowed frequency slip of the IF from the nominal 1 mc. Two principal factors limit the permissible deviation: the IF bandwidth (20 kc) and the sensitivity of the calibration of the phase standard to frequency shifts (0.1 degree per kilocycle deviation from 1 mc). Since the magnitude of the calibration error due to frequency shift is cyclic with phase-shifter angle, it cannot be eliminated with a simple phase-slope network.

The contribution of the IF amplifiers must also be considered. It was not possible to eliminate completely the residue of mistracking between

the phase slopes of the two amplifiers, and what is left amounts to approximately one-half degree per kilocycle. Shifts of the IF occurring in less than $\frac{1}{100}$ second could therefore cause jitter of the phase indication.

Taking all of these factors into consideration, it may be shown that the difference between beat and signal frequencies must be set with a precision of one kilocycle. To meet this requirement at 250 mc, the frequency of the beat oscillator must be settable to one part in 250,000. The severity of this requirement, combined with the obvious inconvenience of having to tune the beat oscillator manually to proper frequency every time the signal oscillator is changed, made it a virtual necessity to control automatically the frequency of the beat oscillator from a sampling of its frequency difference with respect to the signal oscillator.

A discriminator, shown in Fig. 3, centered at 1 mc senses the error of intermediate frequency and delivers an error voltage that actuates two modes of automatic frequency control. The first of these is an electro-mechanical servo which achieves a coarse correction by motor-tuning the frequency of the beat oscillator for minimum IF error. While the motor control is able to keep the beat frequency approximately in step with the signal frequency over the full 250 mc range, it does allow a residual error because of backlash in gearing. Consequently, the mechanical control is supplemented by an all-electronic frequency control which is very narrow in its range but very crisp in its action, and is capable of eliminating the residue of error due to backlash in the mechanical loop.

The automatic control system is shown in some greater detail in Fig. 4. The source of beat signal is a General Radio Company unit oscillator modified for electronic and motor tuning. The full frequency range is covered in two bands. A conventional Foster Seeley discriminator with a sensitivity of 0.2 volt/kc provides the error voltage. After 40 db of direct coupled gain, the error voltage exerts an electronic correction by controlling the dc operating point of an inverse-biased silicon diode network connected across the oscillator tank. The biased diode was selected as the voltage-sensitive reactance because its comparatively low base capacitance permitted it to be most readily integrated into the existing oscillator. Only a small range of electronic control was required, because of the wide tuning capabilities of the parallel-acting servo control.

The prime mover in the servo loop is a two-phase induction motor coupled to the tuning shaft of the oscillator through intermediate gearing; ac error information for driving the motor is obtained from a conventional servo modulator fed by the dc error voltage.

The electronic loop exerts a stabilizing action on the mechanical loop. In fact, the design gain of the mechanical loop is great enough to cause self-oscillation if the electronic loop is disabled. Hence, the electronic

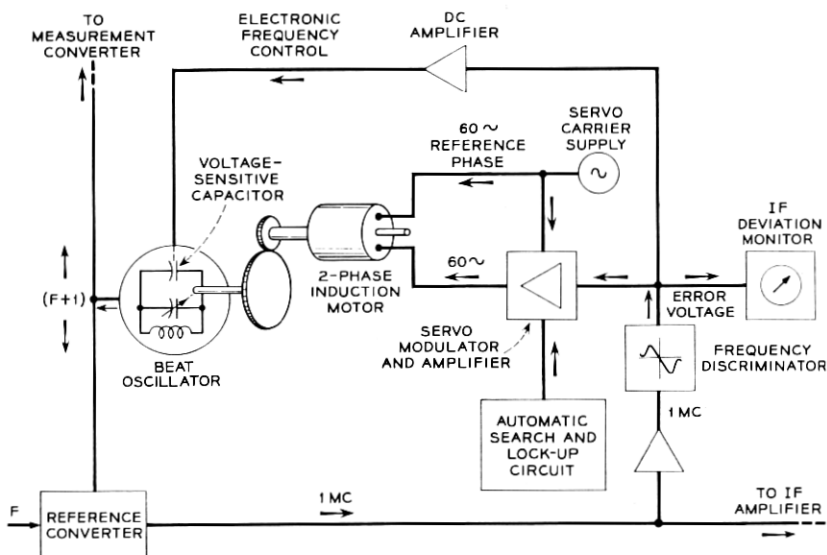

Fig. 4 — Automatic frequency control for beat oscillator, combining servo loop of wide tuning range but limited response rate with narrow-range, fast-acting electronic correction.

loop not only absorbs the remnant of error due to backlash in gearing, but also, by virtue of its greater response rate, introduces the type of stabilization of the mechanical loop that would normally be realized by the use of phase-lead corrective networks.

Neither the electronic nor the mechanical loop gain is constant over the 5 to 250 mc range of the beat source. In the case of the mechanical control, the variation arises because the frequency of the beat oscillator varies logarithmically with the angle of the driving shaft. This enhances the sensitivity of the motor tuning at the higher frequencies of operation. However, the sensitivity of the electronic tuning also intrinsically increases with frequency. Consequently, the electronic loop is capable of providing effective "dynamic braking" over the full 5 to 250 mc frequency range.

An automatic scan circuit causes the beat oscillator to hunt for lock-up when the instrument is first turned on, or whenever synchronization is lost.

4.2 Sampling System and Detection

The block diagram of Fig. 3 and the accompanying description in Section III are intended to clarify the basic principles of the measuring

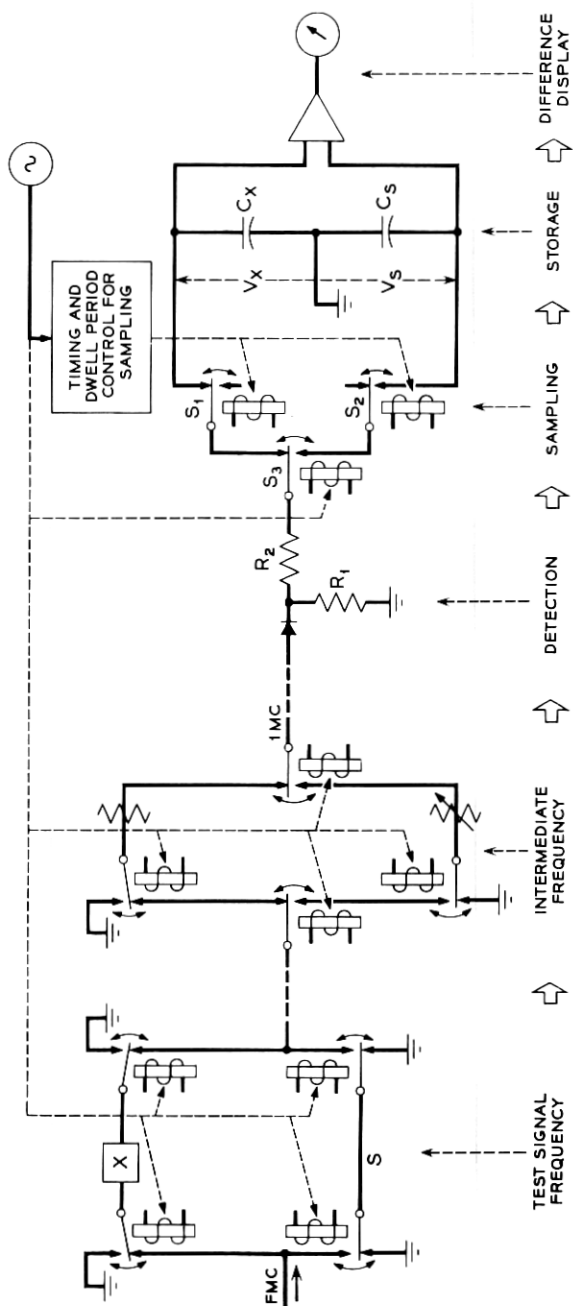

Fig. 5 — Details of rapid-comparison switching in loss measurement.

system. Certain of the significant details of the rapid comparison switching feature as applied to loss measurements will now be taken up. The situation with regard to phase measurements is strictly analogous.

One of the first realities that had to be faced was capacitance between open and transmitting paths in the comparison switches. Even though this capacitance was only 0.3 micromicrofarad in the actual relays used, the crosstalk from this cause could produce large errors when high losses were measured. For this reason, a second double-pole double-throw switch configuration was added at test-signal frequency for the purpose of grounding the open path at both its input and output ends. The complete switching complex is illustrated in Fig. 5.

It is clear that a transmission error results in the comparison of x with s if the contact resistances of the switches are different in their two states of dwell. The problem of contact resistance symmetry is most severe in the case of the switch array operating at test-signal frequency between 50-ohm impedances. In 50-ohm transmission circuits, a resistance asymmetry of 0.5 ohm in just one of the relays would produce an error of 0.1 db. It would be quite easy to obtain far smaller resistance asymmetries than 0.5 ohm in a nonvibratory relay designed for use in low-frequency circuits. But in a relay intended for high-speed repetitive operation both contact area and contact pressure are necessarily limited. With these factors in mind, and considering the extent to which the situation is aggravated by the 250 mc operation, an electromagnetically driven wetted-mercury contact relay element was selected to perform the basic switching function. The resistance asymmetry of this element is estimated to be less than 0.05 ohm at 250 mc. It takes approximately 1 millisecond for the relay to change state. The type of relay element used, in which the mercury is confined by encapsulating the entire relay in a sealed glass envelope, has been described previously.⁵

Coaxial transmission paths are built up by putting the relays inside concentric brass cavities. This serves to minimize the discontinuity when the relays are inserted in 50-ohm coaxial circuits. The cavities are constructed in the form of two mating pieces, which assemble around the relay capsules, as shown in Fig. 6. Each cavity block holds a pair of relays; one block takes care of input switching, the other handles the output. Fig. 6 shows only signal paths through the switch; the coils for driving the movable contacts were intentionally omitted, as well as the shields which prevent coupling between the driving winding and the signal circuits.

An effort was made to maintain 50-ohm geometry by dimensioning the cavity so that the highest possible return losses were realized looking

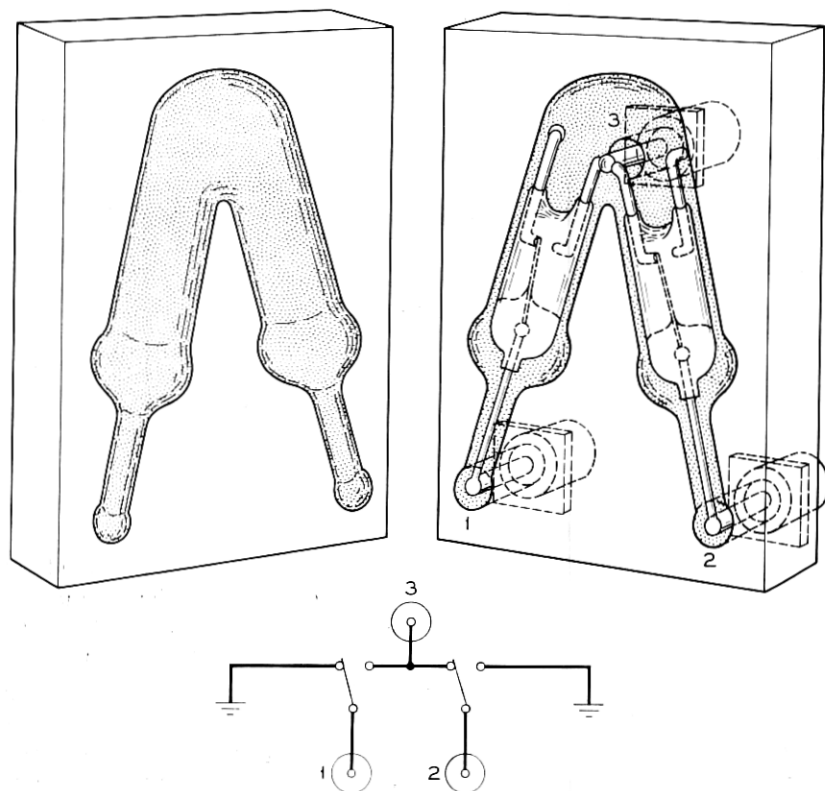

Fig. 6 — 5 to 250 mc comparison switch unit. Glass-encapsulated mercury relays are enclosed within coaxial cavities to provide 50-ohm transmission paths.

into either the 1-3 or 2-3 transmission paths with a match in port 3. Return loss exceeding 35 db was obtained up to 100 mc; between 100 and 250 mc there was a drop to 28 db.

The grounding leads seen in Fig. 6 have sufficiently low impedance to hold crosstalk between ports 1 and 2 to a level of -50 db at 250 mc with a 50-ohm termination inserted in port 3. Thus, the error from crosstalk is less than 0.1 db even when 60-db loss is measured, since switching is done at both the input and output of the unknown.

The design of the comparison switches for use at the 1 mc intermediate frequency posed only minor crosstalk and impedance match problems. Mercury relays were used here, also.

Amplitude detection is accomplished with the linear rectifier shown in

Fig. 5. The system of switches (s_1 , s_2 , s_3) located just beyond the rectifier is instrumental in charging the storage capacitors, c_s and c_x , to voltages proportional to x and s path transmissions. The charging path is through resistor R_2 ; the time constant of R_2c_s and R_2c_x is in the order of 2 seconds. In connecting c_s and c_x during the charging intervals, it is necessary to allow for the physical impossibility of perfectly synchronizing all the relays in the measuring set with respect to instant of contact transfer and uniformity of dwell time. Moreover, short-term transients are initiated at the change of state from x to s and vice versa. For these reasons, a specially timed pair of sampling relays, s_1 and s_2 , is provided to close the charging path through R_2 a short time after the instants of contact transfer in the previous relays.

4.2.1 *Signal-to-Noise Factors*

The points of the measuring circuit at which random noise is sensed are the inputs to the loss and phase difference detectors in the block diagram of Fig. 3. The noise at these points is essentially confined to a 20 kc band by the IF selectivity. There are two disturbing effects due to the noise:

(a) It contributes error by creating a small dc component in the output of the detectors. The amount of this component will be different for the x and s sampling.

(b) It gives rise to fluctuations of the detector outputs. The frequency components of this fluctuation lying within the display bandwidth of the instrument, i.e., within the bandwidth of circuitry following the detectors, contribute jitter on the indicating meters. This affects resolving power.

The present set uses a linear rectifier for the detection of loss, and a "sum-and-difference" type of phase detector⁶ constructed from transformers and linear rectifiers.

The guiding object in setting up level patterns was to have enough signal at the detector inputs to keep errors due to noise less than 0.1 db and 0.5 degree in 60-db loss measurements at 250 mc. Rather than operate at S/N levels significantly higher than necessary to meet this criterion, any extra margin was traded off in the form of lighter signal excitation of unknowns and extra impedance masking with loss pads.

For the linear detector used, it may be shown that the dc offset due to noise leads to an error of 0.1 db at an input S/N ratio of approximately 14 db.⁷ This fact, considered together with converter noise figure and impedance masking requirements, resulted in the following allocation

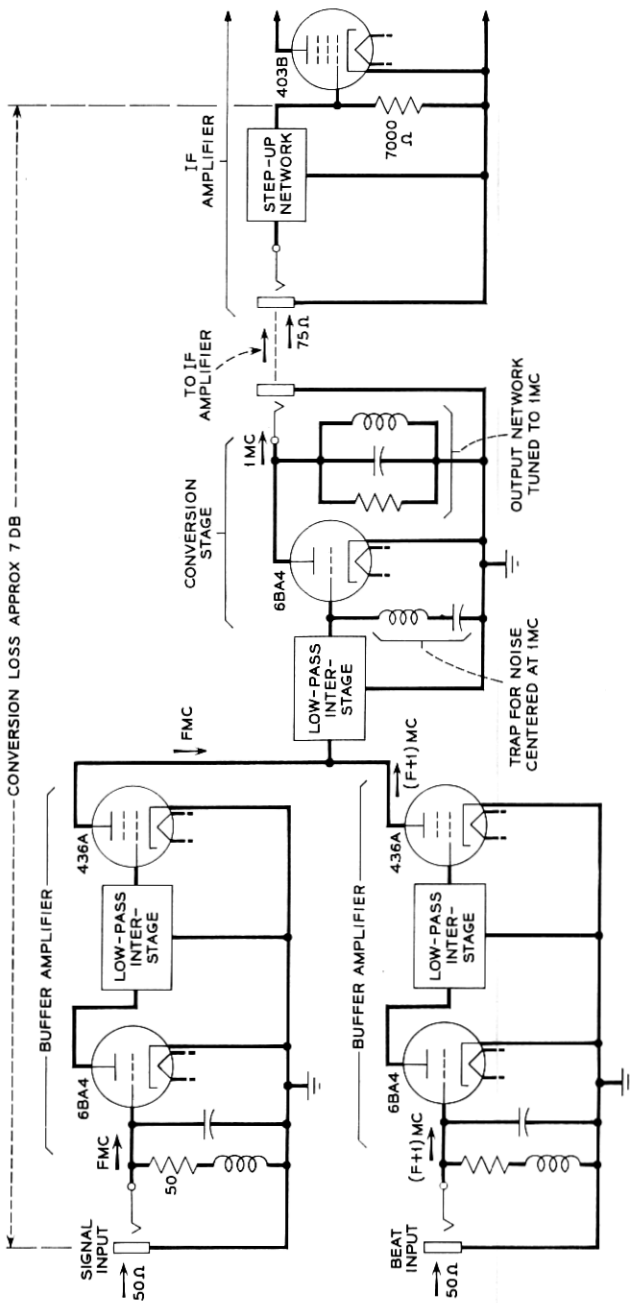

Fig. 7 — Converter circuit.

of signal power to unknowns as a function of loss level:

<i>Loss Level</i>	<i>Drive to Matched Unknown (dbm)</i>
0	-40
10	-30
20	-20
30	-10
40	-10
50	-10

As already noted in Section 4.1.1, the power to the unknown is automatically varied by ganging the IF loss standard to common-path attenuation inserted at the test signal frequency.

The contribution of input noise to mean voltage at the output of the sum-and-difference phase detector is dependent upon the phase difference between the two input carriers. When the carriers are 90 degrees out of phase, there is no dc offset due to noise. Consequently, it is most advantageous to operate at quadrature. However, because of the residue of conversion-phase mistracking between the two converters, it was not possible to establish a 90-degree operating point over the full 250 mc span of test-signal frequency. At null balance, the maximum variation from quadrature is about 30 degrees, and this leads to a shift in dc output corresponding to 0.3 degree at the lowest input S/N ratio of 14 db.

4.3 Conversion

The measurement converter must faithfully transpose amplitude and phase data from the test-signal frequency to the 1-mc intermediate frequency. It must, in addition, have reasonable noise figure and be well matched to 50 ohms at the signal input. Both converters must preserve high isolation between their signal and beat frequency inputs.

The converter design which grew out of these considerations is shown schematically in Fig. 7. Buffer stages provide the requisite high loss between signal and beat frequency inputs. Working back to either input from the point of joining at the grid of the converter tube, the reverse loss is about 60 db at 250 mc. This figure is set by tube and stray capacity.

To preserve the accuracies cited in Section 2.2, it was necessary to compensate the grid circuits of the input amplifiers so that a relatively pure 50-ohm impedance was presented to the driving source. This was mandatory at the signal input, and was also done at the beat-frequency

input. The choice of a 6B3A for the input stage relieved the problem of impedance control. Because this tube, with its low cathode lead inductance, imposes less electronic loading on the driving circuit than does a conventional 6X4 tube. By introducing a small amount of inductance in series with the 50-ohm grid resistor, it was possible to absorb the predominantly capacitive grid-cathode loading. This method of compensation yielded an input return loss of 30 db up to 250 mc. Actually, it was unnecessary to add external inductance. The pig-tail leads of the grid resistor were trimmed to provide the required reactance.

All interstage networks are conventional. The gain from either input to the grid of the converter tube is approximately 0 db at 5 mc and drops 4 db at 250 mc. The 436A stage, operated at a G_m of 30,000 micromhos, is helpful in overcoming the loss of the first tube. A resonant trap at the converter grid prevents the transmission of noise power centered at one megacycle, thereby improving over-all noise figure. This trap is vital because noise centered at one megacycle would actually be amplified by a single-ended converter.

The level of beat-frequency voltage at the converter grid is such that the converter stage operates in a square law mode, rather than as a switch-type modulator. Signal-frequency excitation at the converter grid never exceeds 0.03 volt, with the result that the nonlinearity error, even for the largest signals, is negligible. The conversion loss, as measured from signal input jack to the grid of the first stage of the IF amplifier, varies from 3.5 db at 5 mc to 12 db at 250 mc. At 5 mc, the noise figure is approximately 28 db, decaying to 36 db at 250 mc. The principal factor determining the noise performance is the relatively high ratio of amplification to conversion gain in the converter stage. With the noise figure data just quoted, it was possible to meet both the accuracy and measurement range objectives.

The output network of the conversion stage and the input network of the IF amplifier are designed to provide specific impedance and transmission characteristics. First of all, the impedance presented to the plate at the intermediate frequency is made small compared with the tube's dynamic resistance, to assure linearity when it acts as a converter. Secondly, to avoid plate remodulation, the output network presents a short circuit to the modulating carriers. And finally, leak of the carriers to the grid of the IF amplifier is small enough so that the spurious 1-mc component created by modulation in the first IF stage is negligible.

4.4 IF Amplification

The frequency shaping of the IF band is provided by 42 db gain amplifiers of conventional design following the converters in the over-all

block diagram of Fig. 3. The variation in amplifier gain is less than 0.1 db over a 2-kc band centered at 1 mc; the bandwidth between 3-db points is 20 kc. Two 403B (6AK5) vacuum tube stages provide the necessary gain. Input and output impedances are approximately 75 ohms. A schematic of the amplifier is given in Fig. 8.

In addition to the gain shape requirements, a tolerance was imposed on phase-slope tracking between the two amplifiers. This was necessary to avoid jitter of the phase indication due to incidental, low-order flutters of the intermediate frequency not removed by the AFC. Over a frequency shift of ± 500 cycles, centered at 1 mc, the difference of insertion phase shift between the two amplifiers is less than 0.5 degree.

4.5 Loss Standard

The loss standard is a precisely calibrated attenuator operating at IF. At null balance, its loss may be equated to loss or gain of the high-frequency unknown. In addition to high calibration accuracy and low aging, the standard must have one other extremely important property—its phase shift must be independent of loss setting. This last attribute is very necessary, since the phase-difference detector cannot distinguish phase change of the loss standard from phase change of the unknown.

The standard is built up of four variable resistive attenuators connected in series. The impedance level is 75 ohms. The standard has discrete calibrated steps of 10, 1, and 0.1 db, and a continuously variable vernier covering a range of 0.2 db. The total range covered is 61.1 db.

Carbon film resistors are used throughout, in order to meet the constant-phase requirement with minimum effort. The resistors are of good

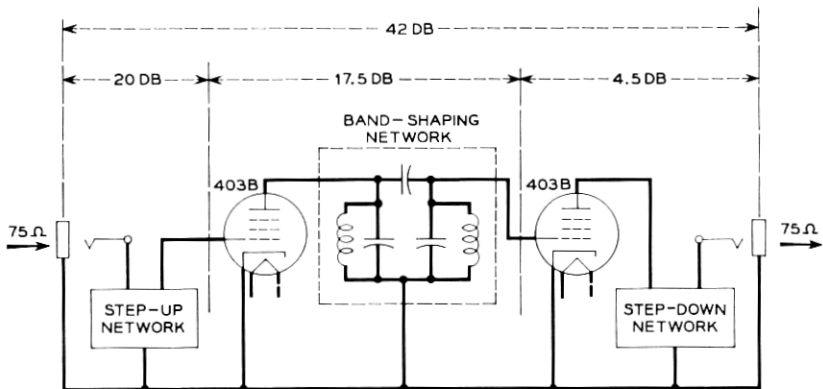

Fig. 8 — Schematic of IF amplifier.

quality and have high long-term stability, but the initial accuracy is only to within 2 per cent. Resistance errors of this order are capable of causing calibration errors of several tenths of a db on the "tens" db decade, where the attenuation sensitivity to resistor inaccuracy is greatest.

To avoid possible error due to initial tolerance of the resistors, the standard is calibrated precisely at dc. With the aid of resistive computing circuitry ganged to the attenuator decades, the calibration error at each setting of the standard is then projected as a correction factor on an auxiliary meter. This arrangement endows the loss standard with a net accuracy of 0.03 db. The long-term permanence of attenuators of this type has been measured, and it has been found that the calibration drift is less than 0.05 db in several years. Temperature coefficient problems are minor since the measurement set is normally operated in a temperature-controlled environment.

4.6 *Phase-Shift Standard*

At null balance, the phase-shift standard is direct reading in terms of the unknown's insertion phase shift. It must have a range of 360 degrees, and a calibration accuracy to 0.2 degree. Since the phase standard does not affect the loss difference detector, its gain may be permitted to vary slightly with phase-shift angle.

The heart of the phase standard is a continuously variable four-quadrant sine condenser of high quality and permanence.⁸ It has two linearly subdivided scales: a coarse 0 to 360 degree calibration on a cylinder connected directly to the rotor shaft of the condenser, and a 0 to 10 degree vernier dial connected to the rotor shaft through reduction gearing. Both of these dials are coupled to their respective shafts by friction clutches, so they may be arbitrarily set. This allows the operator to set up a "phantom zero," by slipping the dials to indicate zero after null-balancing the standard. A considerable amount of arithmetic is saved during relative insertion phase measurements when this technique is used to establish a dummy "zero" at the reference frequency.

The difference of insertion phase shift between two different test signal frequencies is read out as a difference between two dial settings. Therefore, an error arises if the actual difference of phase shift introduced by the standard is not precisely equal to the nominal phase difference read from the calibrated dials. Owing to the linearity error of the sine condenser used, the discrepancy between actual phase change and indicated phase change could range up to 2 degrees.

The imperfection of the sine condenser is absorbed by transcribing its

error curve to the periphery of a cam driven by the rotor shaft. A follower, contacting the cam periphery, then automatically adjusts an incremental phase shifter by the amount necessary to reduce the scale error of the standard to less than ± 0.2 degree. Fig. 9 illustrates the principle of the correction.

V. TRANSISTOR MEASUREMENT

5.1 Coaxial Jig and Fixtures

The first problem to be solved in making broadband transistor measurements has to do with providing a suitable transition from the round coaxial geometry of the test set ports to the pig-tail lead geometry of the transistor. The object is to bring the 50-ohm measurement plane right up to the base of the transistor header. As suggested in Fig. 10, this may be done by forming short sections of 50-ohm transmission line right under the header, using the active terminal wires of the transistor as inner conductors.

Fig. 11 shows the actual jig worked out using this principle. Each of the two cylindrical holes in the top of the jig forms a 50-ohm transmission line with one of the terminal wires of the transistor under test. The rudimentary coaxial line runs for about one-half inch before it merges with a short section of 50-ohm strip line consisting of a narrow rectangular conductor between ground planes. A 50-ohm type N coaxial con-

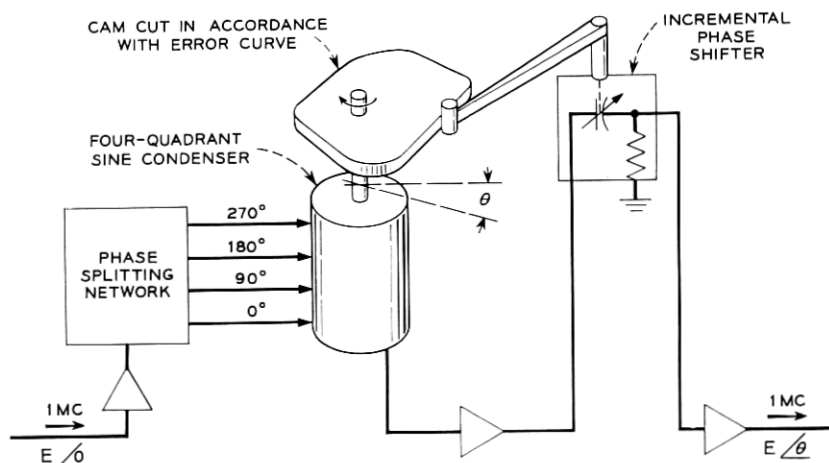

Fig. 9 — Block diagram of phase standard, showing how nonlinearity error of the sine condenser is cancelled by introducing phase corrections with an incremental phase shifter actuated from the error curve.

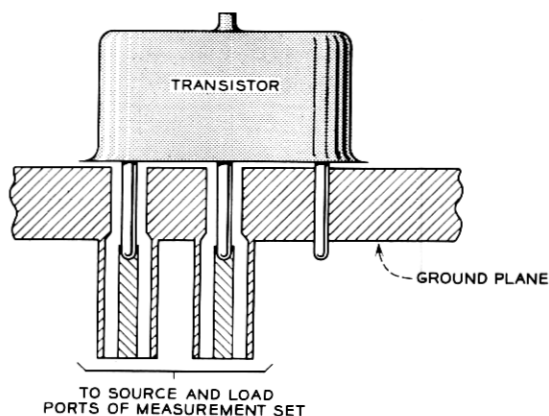

Fig. 10 — Principle of extending 50-ohm geometry to base of header by using transistor lead wires as inner conductors of 50-ohm transmission lines.

nector, inserted in the base of the jig, completes the transmission path. In spite of the discontinuities from joining of geometrically dissimilar lines, measurements indicate that the path through the jig introduces a return loss of 34 db at 250 mc.

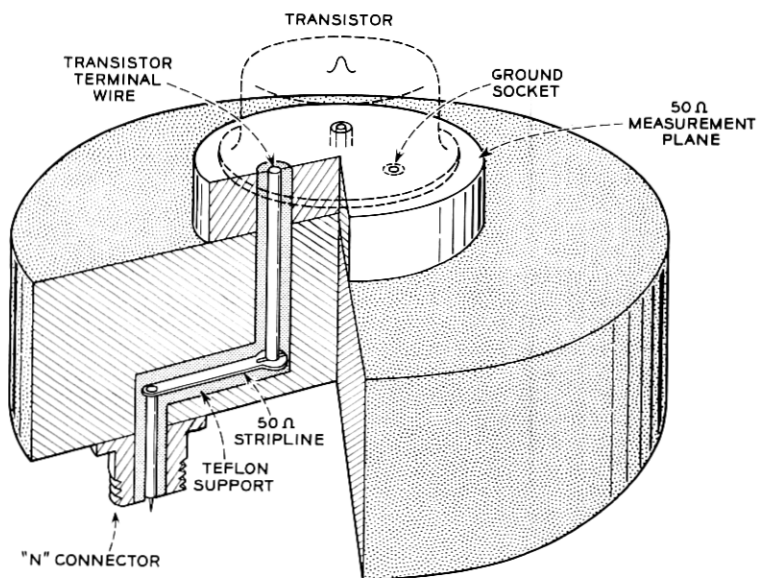

Fig. 11 — Sectional view through actual transistor test jig, showing how 50-ohm transmission geometry is preserved.

The next step is to introduce the biasing currents and voltages to make the transistor active without adding impedance discontinuities. This is done with the aid of the specially designed coaxial pads shown in Fig. 12. The shunt arms of these pads are well by-passed to ground for signal frequencies between 5 and 250 mc, but they are conductively isolated from ground. It is therefore possible to introduce dc biasing and monitoring facilities at the by-passed nodes of the shunt arms without impairing the transmission purity of the signal path. Identical biasing arrangements are provided for both input and output electrodes.

The pad is composed of the elements shown in Fig. 13. A rod resistor forms the series arm, and disc resistors are used for the shunt arms. The by-pass capacitors are physically small but large enough in capacitance value to provide negligible impedance down to 5 mc. All elements are assembled in a coaxial structure. The cavities in the coaxial housing are machined to the optimum diameters for minimum reflection from the terminated pad. With this type of structure, it was possible to obtain return losses of 44 db at 125 mc and 36 db at 250 mc.

This arrangement would have doubtful value unless the activating currents from the bias supplies were confined to the transistor. None of the energizing current may be allowed to flow back into the generator impedance or into the load impedance in an indeterminate way. For this reason, blocking capacitors are used to isolate the test set from the bias

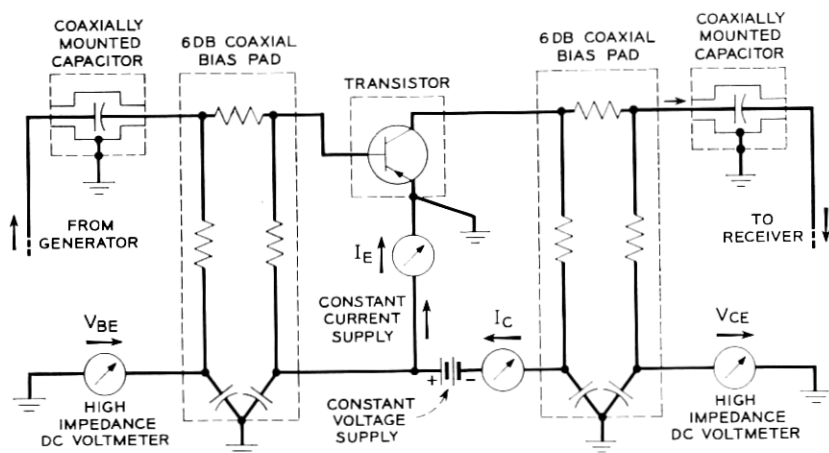

Fig. 12 — Signal and biasing paths during grounded-emitter measurements on a p-n-p transistor. Discontinuity due to biasing is minimized by feeding activating current through shunt legs of well-matched 50-ohm attenuation pad. Blocking capacitors prevent flow of biasing current back into measurement set.

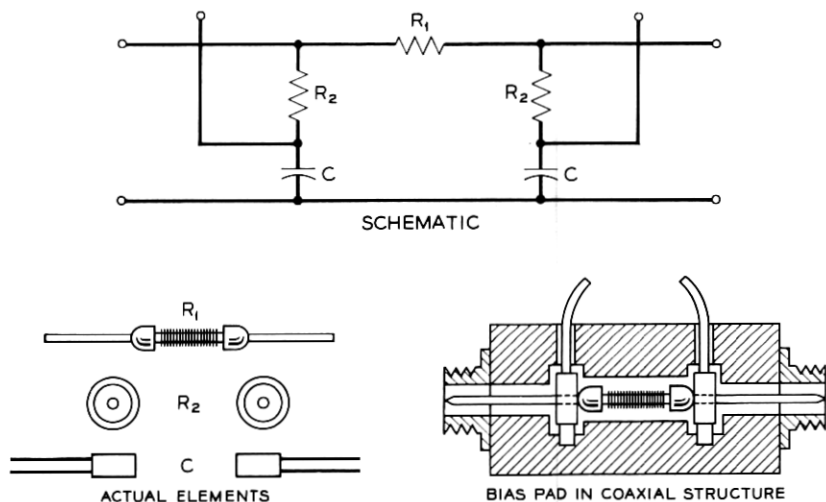

Fig. 13 — Bias pads coaxially constructed to preserve 50-ohm geometry. The shunt capacitance in each leg actually consists of three miniature capacitors inserted in parallel at points 120 degrees apart along periphery of shunt resistors R_2 .

pads. Like the bias pads, the capacitors must be designed for minimum reflection, since they lie directly in the transmission path.

The capacitors are therefore enclosed in special coaxial housings to make them appear like short lengths of 50-ohm coaxial line. Fig. 14 illustrates the construction. The basic capacitance of 0.7 microfarad is provided by a tubular condenser whose shell is one of the electrodes. This large capacitance is necessary because phase shift-free transmission is required down to 5 mc. To permit the condenser to be inserted in a 50-ohm structure with minimum discontinuity, a pair of conically tapered electrodes are fitted to its terminals. This assembly forms the inner conductor of a short section of coaxial line. The corresponding outer conductor, which is shown disassembled, consists of three pieces, specially tapered to match the cigar-shaped inner conductor. A capacitive ring may be seen in the center piece of the outer conductor. The ring was introduced for the purpose of absorbing the remnant of reflection from the condenser's inductance and from the tapers. Measurements indicate a net return loss of 44 db at 125 mc and 34 db at 250 mc.

5.2 DC Biasing and Monitoring Facilities

Since the set was intended to be capable of measuring the variation of small-signal parameters with shift of biasing levels, it was important

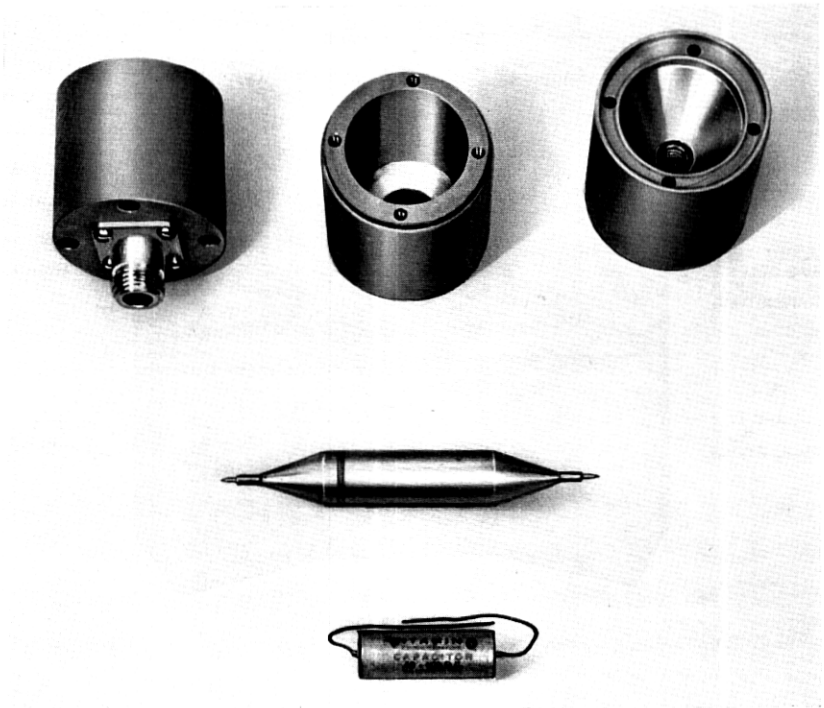

Fig. 14 — Disassembled view of blocking condenser: 0.7-microfarad capacitor is mounted in coaxial structure to make it look like a short section of 50-ohm transmission line.

to provide means for adjusting to a wide range of operating points. Three power supplies are provided for this purpose. Each is capable of being operated as a constant voltage or as a constant current supply. The third supply is used for tetrode measurements.

A system of monitoring operates in combination with the power supplies to facilitate setting of operating points.

VI. EQUIPMENT ASPECTS

6.1 *Over-all Layout*

The instrument is housed in a three-bay cabinet with the two end bays slanted inward to make it easier for a centrally located operator to read dials and manipulate knobs. This arrangement is shown in Fig. 15.

Just above table level in the central bay is the programming center. By means of pushbutton controls on the programmer, the operator can

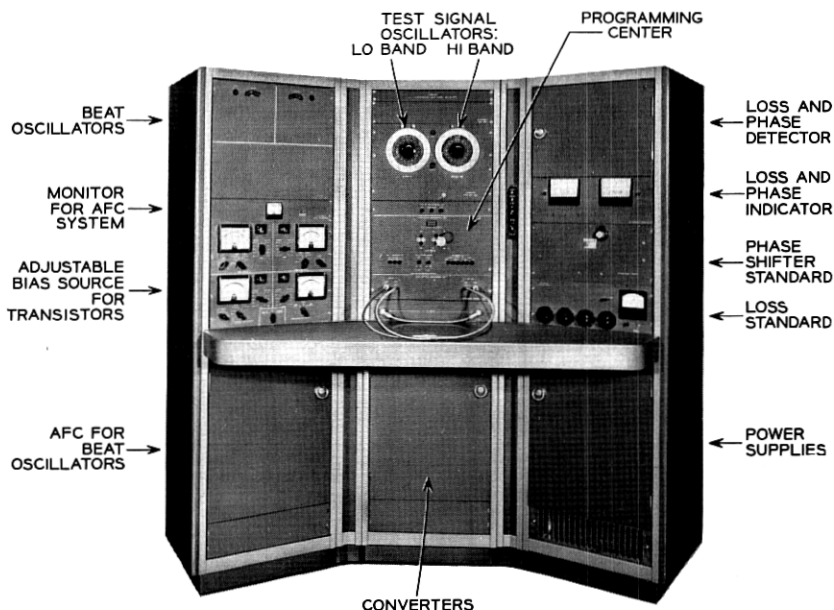

Fig. 15 — 5 to 250 mc phase and transmission measuring set.

set the machine up for 50- or 75-ohm insertion measurements on coaxially terminated networks, or for transistor measurement in grounded base, collector, or emitter configurations. The programmer includes jack appearances for inserting networks or transistors to be tested. Above the programmer is the test-signal source with its two large dials for selecting test frequency on either the low band (5 to 50 mc) or high band of operation (50 to 250 mc). The converters which translate the measurement data to the 1 mc detection frequency are located in the central bay (behind hinged panel) just below table level.

The beat-frequency source for the converters is mounted in the left hand bay. Automatic control circuitry in this bay maintains the beat frequency at the required 1 mc offset with respect to the frequency of test signal. Below the beat source are the biasing supplies for providing known dc energizing currents and voltages to transistors being tested.

The right-hand bay houses the loss and phase detector circuit, loss-and phase-indicating meters, and calibrated phase shifter and loss standards.

Power supplies and the remainder of the test set components are located below table level in the front and in mounting space available in the back.

6.2 Programming Features

A considerable measure of automatic operation has been introduced to make manual patching changes unnecessary when transferring among the various measurement modes. The necessary signal path changes from 50 ohms to 75 ohms or to transistor measurement are all effected by solenoid-actuated coaxial relays that receive their command signals from pushbuttons located on the central programmer unit. These may be seen in Fig. 16. The upper row of pushbuttons selects one of the three broad measurement categories, 50 ohms, 75 ohms, or transistor. If 50- or 75-ohm measurement is chosen, the unknown is connected to the appropriate ports in the lower part of the programmer.

Coaxial relays are also used to set up automatically the internal signal paths for each of the possible transistor measurements. By pushing the appropriate buttons, the operator may program the machine for six different measurements, with any terminal of the transistor being

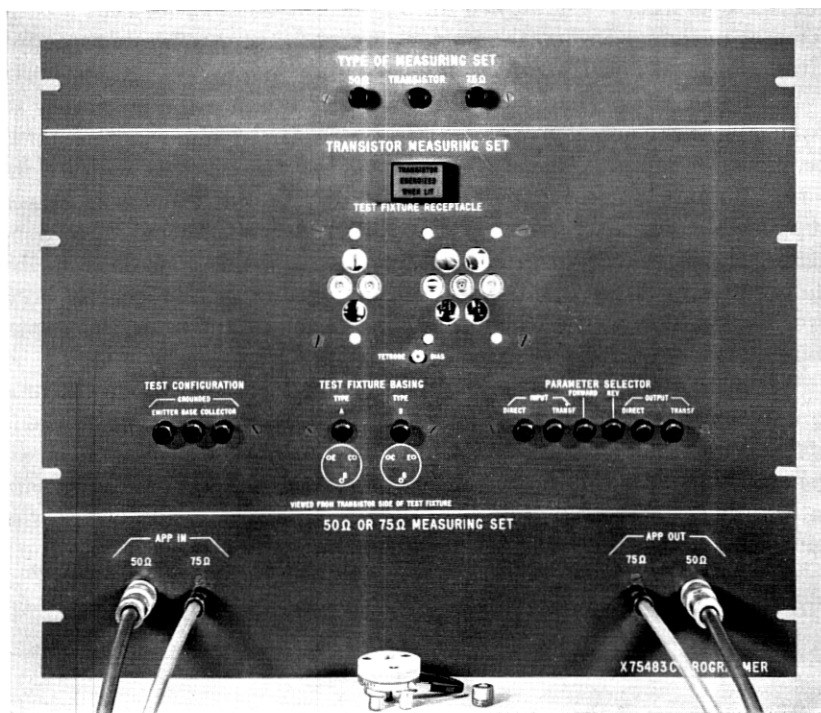

Fig. 16 — Programming center: solenoid-operated coaxial switches automatically set up signal paths for 50-ohm, 75-ohm, or transistor measurement configurations on command from front panel pushbuttons.

taken as common. These six measurements cover forward and reverse transmission and input and output bridging loss, with or without impedance inversion by the quarter-wave line. The unknown path is completed externally by plugging the jig into the centrally located jack field labeled "Test Fixture Receptacle" in Fig. 16. It is evident that special keying information must be given, since there are six ways to insert the jig, corresponding to the six possible measurements. The keying is done with the aid of six illuminable apertures located around the boundary of the test fixture receptacle. A particular one of the apertures automatically lights up in response to the specific combination of buttons that the operator has pushed. The jig is then oriented, before insertion, so that the grounded electrode of the transistor adjoins the illuminated aperture.

The biasing and programming circuitry is coordinated to keep the dc operating point unchanged during a shift from one measurement parameter to another. For example, if the operating point for grounded-emitter operation is established during measurement of forward loss, it remains unchanged when the buttons are pushed for reverse loss or for either of the two bridging measurements.

A number of safeguards were introduced to reduce the possibility of damaging transistors by operator errors. The most important of these provides for initial setup of approximate operating points with an internal dummy resistor network substituted for the transistor. Power supplies and auxiliary circuitry have been designed to minimize dangerous transient currents and voltages when transfer is made from the dummy network to the transistor. Moreover, special care has been exerted to insure that all biases are transferred at the same time, with minimum relative lag.

When the transistor is energized, a warning light appears on the programmer panel to remind the operator not to withdraw the jig without first switching off the biases. This precaution is taken because it is not generally possible to pull the jig out in such a way that all biases are interrupted at precisely the same instant. Conversely, the operator is cautioned against inserting the jig when the warning light is on.

VII. ACCURACY CONSIDERATIONS

7.1 *Validation of Accuracy*

The accuracy of the set was validated by a technique which did not require VHF standards of loss or phase shift. As a first step, the insertion loss and phase of each of four coaxial pads were measured. A meas-

TABLE II

Frequency (mc)	Arithmetic sum of loss and phase measurements on four 10-db pads		Measured loss and phase of cascade connection of the four 10-db pads		Magnitude of the difference	
	Loss (db)	Phase (deg)	Loss (db)	Phase (deg)	Loss (db)	Phase (deg)
5	39.99	2.4	39.87	1.9	0.12	0.5
50	39.91	20.7	39.87	20.4	0.04	0.3
115	39.99	47.3	39.94	46.4	0.05	0.9
225	40.02	93.4	39.98	93.0	0.04	0.4

urement was then made of the over-all loss and phase through the four pads connected in tandem, and the result compared with the arithmetic sum of the measurements on the individual pads. This comparison provides a measure of error which is independent of the loss of the pads or of their separate phase shifts, provided the pads are sufficiently well matched to 50 ohms to insure that interaction and mistermiation effects are negligible. For the purpose of this test, pads of 35 db return loss were adequate. Measurements were made at a number of widely separated frequencies in order to uncover any latent pickup or cross-talk errors. Results are shown in Table II.

A similar check performed with two 10 db pads gave the results of Table III.

A further confirmation of the phase measurement accuracy was obtained by measuring the insertion phase shift of a section of precision 50-ohm coaxial line at a large number of frequencies. The line had a phase slope of approximately 0.5 degree per megacycle. Nowhere in the 5 to 250 mc band did the measured phase shift deviate by more than 0.3 degree from the linear phase characteristic drawn through the measured points.

TABLE III

Frequency (mc)	Arithmetic sum of loss and phase measurements on two 10-db pads		Measured loss and phase of cascade connection of the two 10-db pads		Magnitude of the difference	
	Loss (db)	Phase (deg)	Loss (db)	Phase (deg)	Loss (db)	Phase (deg)
5	20.01	1.2	19.98	1.1	0.03	0.1
50	19.97	10.5	20.01	10.3	0.04	0.2
115	20.02	23.5	20.01	23.2	0.01	0.3
225	20.03	46.3	20.03	46.1	0.00	0.2

7.2 Residual Errors

The principal remaining errors are those due to residual mismatches and to calibration errors of the loss and phase standards.

It is a fairly simple matter to compute loss and phase errors due to mismatches for measurements in the 50-ohm mode, because a high degree of symmetry exists, in this case, between the standard and unknown high-frequency channels. As was seen in Fig. 3, the only physical asymmetry is introduced by the mode-selecting relays in the unknown channel. However, measurements have shown that the path through these relays creates a reflection of not more than 0.01, even at 250 mc. Consequently, it is reasonable to consider that the effect of the relays is to introduce a flat time delay, which may be balanced by an equivalent length of coaxial cable added to the standard channel. The reflection from the attenuation pads is also less than 0.01, and therefore negligible.

Since both the *s* and *x* channels are essentially free of lumped discontinuities, it is possible to adjust cable lengths and arrange components symmetrically so that the impedances seen looking toward source or load from the mid-plane of the 12 db pad in the standard channel match those presented to the input and output ports of the unknown apparatus. Moreover, symmetry is sufficient to insure equal Thevenin generators at the mid plane of the 12 db pad and at the input port of the unknown. Symmetry also leads to equal transmissions from the reference plane in the *s* channel, and from the output port of the unknown, to the common point of convergence at the comparison switch preceding the measurement converter.

Under these circumstances, Appendix B shows that the loss and phase measurement error due to modest mismatches, when measuring passive, bilateral unknowns, is contained in the expression

$$\varphi \approx -s_{11}G - s_{22}L + GL, \quad (2)$$

where φ is in nepers and radians. The quantities G , L , s_{11} , and s_{22} are the reflection coefficients of the generator termination, load termination, and physical input and output scattering coefficients of the network under test, all taken with respect to the nominal impedance level (50 or 75 ohms).

If the phase angles of all quantities add up in the most pessimistic way to produce maximum loss error, (2) indicates that the error in loss or phase measurement may be as great as

$$\varphi_{\max} = |s_{11}G| + |s_{22}L| + |GL|. \quad (3)$$

For example, consider the situation at 250 mc in the present set.

Generator and load terminations, as seen from the unknown in the 50-ohm measurement mode, exhibit reflection coefficient magnitudes close to 0.04. Therefore, in measuring networks whose input and output scattering coefficients are, let us say, 0.1 with respect to nominal, the error in the loss measurement may be as much as

$$2(0.1)(0.04) + (0.04)^2 = 0.0096 \text{ neper,}$$

or approximately 0.08 db. If the reflections were phased to produce greatest phase measurement error, (2) leads to the conclusion that the inaccuracy, in this example, could be as large as 0.01 radian, or 0.56 degree.

It is of interest to observe the dependence of the error magnitudes on the network's own imperfections. Assuming network reflections of 0.04 instead of 0.1, the errors drop to 0.04 db and 0.27 degree, without postulating any improvement in the source and load termination.

7.3 *Elimination of Errors Due to Mismatched Terminations During Impedance Measurements*

Impedances are determined by inference from bridging loss and phase measurements. When seeking highest measuring accuracy with this method, a number of secondary imperfections in the set must somehow be accounted for:

- (a) impedance deviation of source and receiver terminations from the nominal value;
- (b) existence of a transmission and phase "zero-line," amounting to 0.1 db and 2 degrees between 5 and 250 mc;
- (c) difficulties encountered at high frequencies in precisely defining the location of the measurement plane;
- (d) finite loss of the quarter-wave transformer and deviations from precise quarter-wave length when measuring high impedances;
- (e) inherent transmission and phase-measurement errors of the loss and phase standards in the set; this also includes nonlinear effects in the modulator.

These factors may easily lead to measuring errors of the order of 10 per cent, especially at the higher frequencies of operation.

If the object is maximum accuracy, without regard to volume of computation, it is possible to calibrate the set so that the errors listed in (a) through (d) are largely eliminated. Computation may be only a minor factor if a digital computer is available to handle large amounts of calculation. The self-calibration procedure is based on the observation that, during impedance measurement, the set essentially measures

the complex transmission from an input port to an output port as a function of the value of an unknown impedance, Z , connected across a third port. It follows that the measured insertion loss and phase shift associated with Z must be of the general form

$$e^{-\theta} = \frac{a + bZ}{1 + cZ}, \quad (4)$$

where a , b , c are constants dependent only on the interior network of the set.⁹ These would in general vary with frequency. Their values, however, may be obtained by measuring insertion loss and phase shift for three known values of Z . All residuals except item (e) are then automatically included in the a , b , c factors.

The practicability of this procedure was checked in the following way. First, the a , b , c constants were evaluated at approximately 10 frequencies, by measuring a coaxial short ($Z = 0$), a coaxial open ($Z = -j\infty$), and a high-quality termination ($Z = 50$ ohms). The planes of the "open" and of the "short" were designed to coincide, and they actually did so within a tolerance of 1 millimeter. Finally, a fourth impedance of known properties — a 30-centimeter length of precision 50-ohm line shorted at the far end — was inserted, and its impedance was computed from the relationship in (4), using the measured loss and phase data. All differences noted between the theoretical impedance value and the measured value were accounted for by the set's intrinsic loss and phase measurement inaccuracy [item (e) above].

VIII. TYPICAL MEASUREMENT RESULTS

One of the major uses of the set has been to provide measurement data for computing transistor h parameters up to 250 mc. A typical case was the characterization of broadband diffused-base germanium transistors in the grounded emitter configuration.

In measuring the two bridging parameters, the technique described in the last section was used. This consisted in making three preliminary insertion loss and phase measurements with three known impedances successively bridged across the 50-ohm transmission path: a "short," an "open," and a high-quality 50-ohm termination. A fourth measurement was then made looking into the transistor-loaded jig with the remote port terminated in a 50-ohm standard. Using the data of the first three measurements, it was possible to correct the fourth measurement for secondary sources of error contributed by the test set.

An error would normally result if the calibration impedances did not effectively lie in the plane defined by the base of the transistor header.

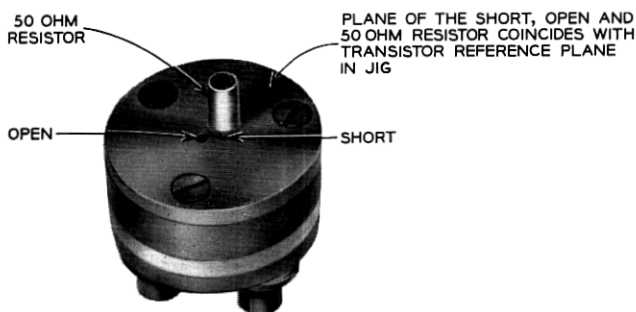

Fig. 17 — Calibrating fixture for use during transistor impedance measurements.

Fortunately, a ready-made solution to this problem was already available. By using the techniques employed in designing the transistor jig, it was possible to construct a companion fixture for unambiguously locating the three calibrating standards in the desired plane.

The calibrating fixture, which is shown in Fig. 17, has three internal 50-ohm transmission paths between the ports in the base and the top surface. One path terminates in a "short," another in an "open," and the third in a miniature 50-ohm film resistor enclosed in a conducting hood. Measurements indicate that the return loss presented by the 50-ohm resistor is greater than 34 db up to 250 mc. Since the path lengths have been made equal to those used in the jig, the plane of the standards coincides with that of the unknown. The calibrating fixture is successively inserted into the set in three different orientations, to present, in sequence, the "open," the "short," and the 50-ohm standard to the test set port that senses the transistor impedance.

The work in transforming from the measured data to h parameters was performed by a computer. A total of seven measurements had to be assimilated at each frequency: forward and reverse insertion loss and phase, the three calibrating measurements for correcting bridging loss and phase data, and, lastly, the input and output bridging measurements. A program already existed for converting from the scattering to the hybrid parameter matrix, so the computer first transformed the measurement data to an s matrix. The final output consisted of the frequency characteristics of the four h parameters. By way of example, Fig. 18 shows the variation of the magnitude and angle of h_{21} for one of the transistors tested. Notice that the phase of h_{21} is asymptotic to -90 degrees in the vicinity of 250 mc, which is consistent with the 6 db per octave slope in the magnitude characteristic starting from about 50 mc.

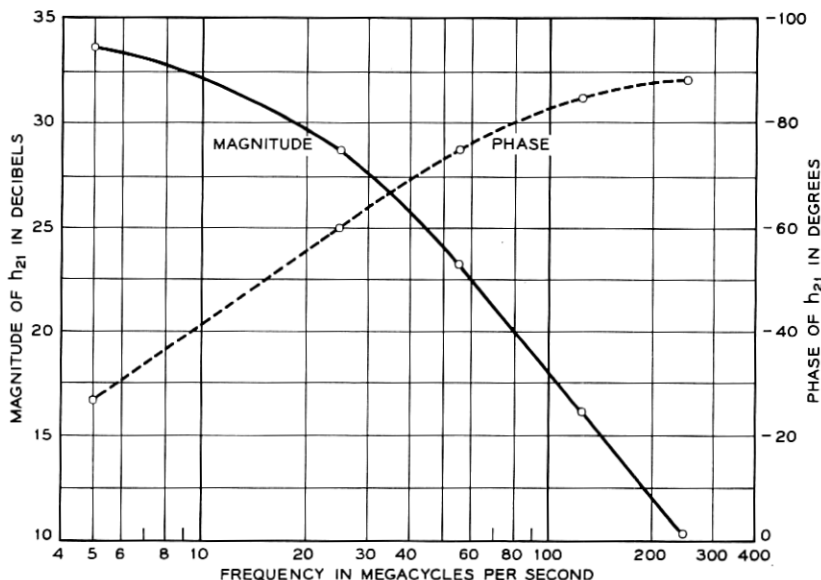

Fig. 18 — The h_{21} parameter for an A2104 transistor; grounded emitter, $I_E = +10$ milliamperes; $V_{CE} = -10$ volts.

IX. ACKNOWLEDGMENTS

The design of the automatic frequency control system for the beat oscillator is due to H. G. Follingstad. E. Widmann was responsible for design of the transistor jig and measurement features. The over-all mechanical design is the result of the efforts of R. P. Wells. Particular credit must be given to W. J. Fischer, who tested the circuits and cooperated in the development of various sections of the set. The construction of the transistor and calibrating fixtures and the transistor measurements were under the direction of J. Sevick. The mechanical assembly of the phase standard was due to J. Pasiecznik, while L. Howson and W. G. Hammett provided the design and calibration of the error correcting incremental phase shifter.

The authors are especially indebted to S. Doba, Jr., for much helpful criticism and advice.

APPENDIX A

Relation of Measured Quantities to Scattering Parameters

The insertion ratio of a network is defined as E_s/E_x in Fig. 19. The input-output scattering coefficient of a two-port network is the reciprocal

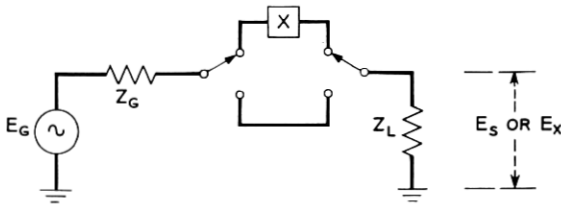

Fig. 19 — Network with insertion ratio E_S/E_X .

of the measured insertion ratio, provided the measurement is made between terminations equal to the normalizing numbers for the scattering matrix.¹⁰ If $e^{\varphi_{12}}$ and $e^{\varphi_{21}}$ are the insertion ratios for the two directions of transmission, then

$$s_{12} = \frac{1}{e^{\varphi_{21}}}$$

and

$$s_{21} = \frac{1}{e^{\varphi_{12}}}.$$

In the present set, the source and load terminations are equal. It is therefore only necessary to show how s_{22} and s_{11} relate to measured insertion ratio during bridging measurements, when the remote port of the unknown is terminated in the common load resistance. Under these conditions, the impedance, Z , in equation (1) of the text, is the impedance presented by the network with the remote port terminated in its normalizing number. Thus, if port 1 is bridged,

$$\frac{Z_{11}}{50} = \frac{1 + s_{11}}{1 - s_{11}}$$

and, for port 2,

$$\frac{Z_{22}}{50} = \frac{1 + s_{22}}{1 - s_{22}}.$$

These two equations, together with (1), lead immediately to

$$s_{11} = \frac{3 - 2e^{\varphi_{11}}}{2e^{\varphi_{11}} - 1}$$

and

$$s_{22} = \frac{3 - 2e^{\varphi_{22}}}{2e^{\varphi_{22}} - 1}.$$

APPENDIX B

Insertion Ratio Measurement Errors Due to Mismatch

With the aid of Fig. 19, we define insertion ratio as the quantity E_s/E_x , where E_s is the voltage across Z_L when a path of zero loss and negligible length is connected between source and load, and E_x is the load voltage when the unknown is inserted. $|E_s/E_x|$ is insertion loss expressed as a numeric, and $\angle(E_s/E_x)$ is the insertion phase shift.

We deal here with the common situation in which the nominal or "design" value of source and load is some impedance, Z_0 . In the actual measurement situation the source impedance, Z_G , and load impedance, Z_L , are slightly different from Z_0 . The mismatch error, ϵ , is contained in the quotient

$$\epsilon = \frac{\text{measured insertion ratio}}{\text{insertion ratio between design terminations}}. \quad (5)$$

It is desirable to obtain an expression for ϵ in terms of the scattering parameters of the unknown with respect to Z_0 terminations. This is preferred because of the close connection between the coefficients of the scattering matrix and readily measured quantities at high frequencies. Such a relationship is easily obtained by expressing the circuit properties of Z_G , the intermediate network, and Z_L in terms of their wave transmission matrices. It will be recalled that this matrix relates incident and reflected voltage waves at the ports in the manner

$$\begin{pmatrix} a_1 \\ b_1 \end{pmatrix} = \begin{pmatrix} T_{11} & T_{12} \\ T_{21} & T_{22} \end{pmatrix} \begin{pmatrix} b_2 \\ a_2 \end{pmatrix}. \quad (6)$$

The a 's and b 's are incident and reflected waves traveling on an impedance level of Z_0 ohms. These two equations may be solved for the coefficients of the "T" matrix in terms of scattering parameters:

$$\begin{aligned} T_{11} &= \frac{1}{S_{21}}, \\ T_{12} &= -\frac{S_{22}}{S_{21}}, \\ T_{21} &= \frac{S_{11}}{S_{21}}, \\ T_{22} &= S_{12} - \frac{S_{11}S_{22}}{S_{21}}. \end{aligned} \quad (7)$$

The T matrices of source impedance, network, and load impedance are multiplied to obtain the over-all matrix applicable from the generator terminals (E_g) to the load. The load voltage may then be shown to equal the generator voltage, E_g , divided by the sum of the four coefficients of the over-all T matrix. If the elements of the component matrices are expressed in terms of the scattering parameters [e.g., (7)], the load voltage will involve only the scattering coefficients of the network and reflection coefficients of source and load. This procedure results in the load voltages:

$$E_x = \frac{E_g}{2} \frac{s_{21}(1-G)(1+L)}{1-s_{22}L-s_{11}G-GL(s_{12}s_{21}-s_{11}s_{22})}, \quad (8)$$

$$E_s = \frac{E_g}{2} \frac{(1-G)(1+L)}{1-GL}. \quad (9)$$

The s parameters refer to the unknown network; Z_0 is both the input and output design impedance; G and L are the reflection coefficients of source and load impedance with respect to Z_0 .

Hence the measured insertion ratio is

$$\frac{E_s}{E_x} = \frac{1-s_{22}L-s_{11}G-GL(s_{12}s_{21}-s_{11}s_{22})}{s_{21}(1-GL)}. \quad (10)$$

From (10), we determine the insertion ratio between design terminations (by setting $G=L=0$) to be simply $1/s_{21}$. Hence we have

$$\epsilon = \frac{1-s_{22}L-s_{11}G-GL(s_{12}s_{21}-s_{11}s_{22})}{1-GL}. \quad (11)$$

If $|G|$ and $|L|$ are each much less than unity, and if s_{11} , s_{22} , and s_{21} are reasonably small, as is ordinarily the case, then

$$\epsilon = 1 + \varphi, \quad (12)$$

$$\varphi \sim -s_{11}G - s_{22}L + GL, \quad (13)$$

where φ is in nepers and radians.

REFERENCES

1. I.R.E. Standards on Solid State Devices: Methods of Testing Transistors, Proc. I.R.E., **44**, 1956, p. 1542.
2. Ketchledge, R. W., and Finch, T. R., L3 Coaxial System — Equalization and Regulation, B.S.T.J., **32**, 1953, p. 833.
3. Roetken, A. A., Smith, K. D., and Friis, R. W., TD-2 Microwave Radio Relay System, B.S.T.J., **30**, 1951, p. 1041.
4. Follingstad, H. G., Complete Linear Characterization of Transistors from Low Through Very High Frequencies, I.R.E. Trans., **I-6**, 1957, p. 49.

5. Slonczewski, T., Precise Measurement of Repeater Transmission, *Elect. Engg.*, **73**, 1954, p. 346.
6. Alsberg, D. A., and Leed, D., Precise Direct Reading Phase and Transmission Measuring System for Video Frequencies, *B.S.T.J.*, **28**, 1949, p. 221.
7. Goldman, S., *Frequency Analysis, Modulation and Noise*, McGraw-Hill, New York, 1948, p. 246, eq. (114).
8. Blackburn, J. F., *Components Handbook*, M.I.T. Radiation Laboratory Series, Vol. 17, McGraw-Hill, New York, 1949, ch. 9.
9. Bode, H. W., *Network Analysis and Feedback Amplifier Design*, D. Van Nostrand Co., New York, 1945, p. 223.
10. Carlin, H. J., The Scattering Matrix in Network Theory, *I.R.E. Trans.*, **CT-3**, 1956, p. 88.