

THE BELL SYSTEM TECHNICAL JOURNAL

VOLUME XXXIX

NOVEMBER 1960

NUMBER 6

Copyright 1960, American Telephone and Telegraph Company

Signaling Systems for Control of Telephone Switching

By C. BREEN and C. A. DAHLBOM

(Manuscript received May 17, 1960)

Telephone signaling is basically a matter of transferring information between machines, and between humans and machines. The techniques developed to accomplish this have evolved over the years in step with advances in the total telephone art. The history of this evolution is traced, starting from the early simple manual switchboard days to the present Direct Distance Dialing era. The effect of the increasing sophistication in automatic switching and transmission systems and their influence on signaling principles are discussed. Emphasis is given to the signaling systems used between central offices of the nationwide telephone network and the influence on such systems of the characteristics of switching systems and their information requirements, the transmission media and the compatibility problem. A review is made of the forms and characteristics of some of the interoffice signaling systems presently in use. In addition, the problem of signaling between Bell System and overseas telephone systems is reviewed with reference to differing information requirements, signaling techniques and new transmission media. Finally, some speculation is made on the future trends of telephone signaling systems.

I. INTRODUCTION

Telephony in the United States has now reached the point where it is becoming commonplace for an increasing number of customers to directly dial their calls throughout the nation. By the end of 1959 more

than 15 million main telephones in the Bell Telephone Companies had access to nationwide dialing, and eventually many more millions of telephone users will be able to quickly and accurately communicate with each other in the same way.

To a large degree this modern "miracle" has been made possible not only by the development of the common control switching system but also by advances in the art of signaling. Just as the switching function has sometimes been called the "giant brain", the signaling function might indeed be thought of as a gigantic "nerve system" carrying sensing and action impulses to and from the "brain" to every part of the system, near and far.

Today's communication system, which lets millions of telephone users throughout the nation get in touch with each other within seconds after dialing a number, has resulted from the effort of imaginative telephone people working over the years to evolve new techniques to meet the ever growing communication needs of our nation. The present highly developed state of the art has been brought about by an orderly evolution — an evolution wherein communication needs, plans and techniques, the one stimulating the other, have formed a continuously improving technology. Some appreciation of the place of the signaling art in the modern telephone system can be gained by reviewing this evolution.

II. HISTORICAL REVIEW

In the simple early telephone system, customers needing only to attract the attention of an operator at a switchboard cranked the familiar hand magneto, and thereby immediately brought the signaling function into play. In handling the call thereafter, many of the operator functions involved the concept of signaling. Such functions as becoming aware of calls in various stages of completion, obtaining verbal instructions as to the destination of the call, determining whether the called line is busy or idle, alerting the called station and reporting on the status of the call reduce to information signals of one form or another either to or from the operator. As such, they were either aids to, or results of, the judgment exercised in the operator's handling of calls.

Rather early in the evolution of the telephone it became apparent that the judgment and efficiency of the operator could be helped by improving the signals she was called upon to interpret and produce. Thus, the "drop" gave way to the line lamp, recall and disconnect

signals were displayed on lamps associated with the switchboard cords and signals produced by the operator to advance the call to an intermediate operator or to complete it to the called customer tended to be produced automatically. However, as long as manual switchboard operation prevailed, one part of the call handling process remained relatively unchanged — the verbal transmission of the called number from customer to operator, and from operator to operator.

With the advent of automatic or machine switching it became necessary for people to communicate with machines, for machines to communicate with other machines, and for machines to communicate with people. Machine simulation of many of the signals was accomplished more or less readily since, in practically all cases, the information items could be reduced to two-state signals. For example, either a line is requesting service or it is not; either it is busy or it is not; either it is being rung or it is not; either the telephone is removed from the switchhook or it is "on-hook", etc.

The adequacy of two-state signaling systems for these functions was apparent from the start and has had an important bearing on the subsequent evolution of signaling systems. However, the "addressing" signals, that is, the signals needed for people to tell machines to whom they wish to be connected and for machines to communicate this information to other machines, have a much larger information content than do the signals used for status or control purposes. Consequently, the handling of the "address" function has produced some highly interesting variations during the evolution of telephone signaling systems.

At the beginning, systems used for the automatic transmission of addressing information were based on the use of direct-current electrical pulses, the number of which denoted each decimal digit. Thus, a customer's telephone "address" could be designated by one or more decimal digits and these, in the form of pulses, could be transmitted to, and interpreted by, the switching machine. Of interest is the fact that in some of the earliest systems such pulses were hand-pulsed by the calling party with a pushbutton, different pushbuttons being used for transmitting sequential digits.

A major advance in the art occurred after the turn of the century with the introduction of the dial, a device which rotates back to a stop from a position to which it is pulled, and, in so doing, automatically generates a train of pulses corresponding to the value of the desired decimal digit. These pulsed digits directly positioned the switches. The step-by-step switching system thus evolved from this method of pulsing and the address information — from people to machines and

machines to machines — was conveyed in all cases by pulsed decimal digits.

Panel and crossbar switching systems, which were introduced later, utilized switching mechanisms which did not directly respond to, or follow, the calling subscriber pulses. These systems required auxiliary pulse-receiving and pulse-sending arrangements, known as senders, which received digital information independently of the switch and then controlled the position of the switch in a manner best suited to that device and to the system. The use of these auxiliary signaling arrangements permitted alternative actions by the machine in controlling the switches. The introduction of such arrangements in panel, and later crossbar, systems also had the effect of permitting information storage and signal regeneration in the switching office, thereby opening up possibilities for new interoffice "languages" for transmitting the address information. Thus were born the signaling systems which we now know as revertive, panel call indicator (PCI) and multifrequency. To more effectively utilize the speed capabilities of the sender-type devices, these signaling systems employed multistate signaling techniques.

The transformation to machine or dial central office operation occurred first in local exchange areas, and, since distances were relatively short, DC signal transmission was adequate for the signaling languages used by step-by-step, revertive and PCI systems. The later expansion of machine operation to longer distances, and the handling of toll traffic, accented the need for accuracy and speed, and also for signaling arrangements adaptable to non-DC paths. Out of this grew the extensive use of multifrequency pulsing for the transmission of digital switching instructions. Also appearing on the scene were single-frequency signaling systems, for transmitting trunk control and status information, and for transmitting dial pulses where required by the older switching systems. Single-frequency and multifrequency systems have become the predominant standard for modern exchange and toll applications where transmission of switching and supervisory information is required over AC paths. In fact, transmission of digital switching information by multifrequency pulses not only is used over AC paths but also has become the preferred method of signaling over all paths in toll and exchange switching systems.

These, then, are some of the principal events highlighting the history of signaling in the telephone system. Those close to the art will recognize that much has been left unsaid. We shall forego further detail at this point, however, in favor of an examination of the philosophy and principles underlying the evolution of the signaling art.

III. PRINCIPLES OF SIGNALING SYSTEMS

A telephone system, in simplest terms, consists of a network wherein any customer's telephone station can be used to signal, connect to and talk with any other similar station in the network. Within the framework of this basic system function, modern telephone system design is aimed at meeting numerous objectives — automation, high-grade transmission, accuracy, speed, flexibility are some of the principal ones, not forgetting the all-important objective of engineering economy. The signaling philosophy has evolved during the process of integrating the signaling function with the basic system function, while observing all of the subordinate system objectives.

Modern signaling systems are closely related to common control switching systems. From the viewpoint of the signaling engineer, the common control system appears as a machine receiving external stimuli in the form of instructions and other controls, following which it performs its required switching operations and generates additional information or instructions. Some of the information generated is returned to the source and some, together with original information, is transmitted to an external destination. It is the function of a signaling system to accept source information, convert it to appropriate signals for transmission over telephone lines or trunks, and deliver it to its destination.

The signaling function begins with the acceptance of input information from a source, followed by processes of encoding, signal generation, signal transmission, signal detection, decoding and delivery of information to a destination. While these processes may be combined in varying degrees in different signaling systems, they are nevertheless present in all.

The source and destination of the information transmitted or received by any particular signaling link might be, respectively, a customer's station and a central office, or the reverse. Or both the source and destination might be central offices. In general, an extremity of a signaling system is required to act as both source and destination with respect to the complementary functions at the other extremity.

The relationship of the signaling system to the transmission media constitutes another important factor in the signaling philosophy. Since the transmission facilities in a telephone system are primarily intended to permit customers to talk to each other, the signaling engineer has the choice of signaling over those facilities within the voice-frequency band or, alternatively, signaling outside of the voice band. If the former

choice is elected, one has the satisfaction of feeling that signaling can be accomplished if talking is possible, but is faced with the problem of signal mutilation and signal imitation due to noise or voice-generated signals. If the out-of-band technique is adopted, the signaling engineer is faced with not only the problem of economically justifying additional signaling channels but also the problem of coordinating voice and signal channels.

In some cases there is little left to choice, and this aspect is accepted as part of the signaling philosophy. For example, the transmission plant involved in the interconnection of switching offices might be so rigidly designed and installed that in-band signaling would be the only economic choice. On the other hand, the choice of out-of-band signaling might be patently simple, such as in the case of DC signaling over wire conductors.

For the most part, the prevailing Bell System philosophy is to employ in-band signaling over nonmetallic facilities and out-of-band (DC) signaling over metallic paths. There are departures from this, and these, along with other factors influencing the application of the over-all signaling philosophy, will be discussed later.

In contemplating telephone signaling systems, it is convenient to make a distinction between the systems employed to signal between the customer and the central office and those used to signal between central offices. This distinction is not always appropriate where step-by-step switching is concerned. However, with modern common control central office switching systems, segregation into these two classifications is quite valid, since the central office usually acts as a buffer between customer stations. In the development of modern signaling systems, it has been desirable also to make this distinction between customer-to-central-office systems and central-office-to-central-office systems in order that an optimum choice of signal encoding, generating and decoding arrangements could be made for each category.

The characteristics of customer-to-central-office systems are influenced by a somewhat different environment than that of interoffice systems. For example, conditions under which signal transmission must be accomplished differ, and fewer information requirements exist in the customer-to-central-office environment. In addition, the need for simple signaling transducers (dials, pushbuttons, bells, etc.) at the customer terminals results in a considerably different approach toward customer signaling systems than toward interoffice systems.

As a result, customer-to-central office telephone signaling systems have tended toward relatively simple arrangements which, with minor varia-

tions, have been standardized for all central office switching systems. Confined to operation over dc loops, except for special cases, these systems employ two-state dc (off-hook, on-hook) signals, rugged dc dial pulse generators and simple ac-operated bells. Party identification and selective signaling for multiparty lines represent signal variations unique to this class of signaling system.

It will, of course, be realized that in defining the scope of the customer-to-central-office signaling systems as above, a great deal has been left unsaid concerning the technical problems and solutions involved in obtaining maximum accuracy and range for the customer signaling devices, while at the same time maintaining low cost. It is interesting to note in passing that the long-term standing of the customer's rotary dial and bell combination is being probed by pushbutton dials and tone ringer explorations. We shall confine the remaining discussion of signaling in this paper to the systems used to communicate between central offices, particularly those of the common control type.

From the foregoing, the essential elements of the signaling philosophy may be summarized as follows:

- i. Signaling system objectives are integrated with the prime telephone system technical and economic objectives.
- ii. Signaling system requirements are strongly influenced by, and coordinated with, switching and transmission system techniques and requirements.
- iii. A large degree of mutual independence is maintained between signaling systems used between customers and central offices and those used between central offices.

In the development of this philosophy a number of principles have emerged. They will be stated without discussion below, but the reader will wish to bear them in mind during the remainder of the discussions and descriptions appearing in this paper.

1. It is desirable to consider a signaling system as a *conveyer* of information, separating out and locating the basic information generators and receivers in other parts of the telephone system to which the signaling system is connected. This permits flexible and interchangeable use of signaling systems with various switching systems.

2. It is not necessary nor desirable to "package" all of the required interoffice signaling functions in one system. On the contrary, separation of functions in such a way that some are associated with the switching system and others associated with an interoffice signaling "link" often permits economies, promotes flexible application of the signaling link, and permits adaptation to different signaling "languages."

3. It is desirable to employ the concept of individual signaling links between switching points, with signal interception and repetition occurring at the switch point. In contrast to end-to-end signaling over built-up connections, the use of individual signal links allows information to be modified or inserted at switch points, and permits the use of different signaling "languages" between switching offices in a built-up connection. The signal transmission problem is also minimized.

4. Signaling links which are alike or symmetrical at each terminal are desirable in order to permit reversible use on two-way circuits.

5. The use of simple two-state signaling to accomplish the control and supervisory signaling functions is desirable where possible to simplify the signaling system and improve its operating margins.

6. "Full duplex" or completely independent two-way handling of trunk control and status signals between offices is desirable for simplicity, speed and accuracy.

7. The use of self-checking or error-detecting codes for the transmission of multibit information, such as the address, has proved desirable from technical and economical standpoints.

8. In-band signaling is desirable where application to voice channels is possible. Special cases of out-of-band signaling, such as dc transmission of trunk control and status signals over available metallic facilities are difficult to improve upon, however. New carrier system techniques, now under development, may influence this picture.

IV. FACTORS INFLUENCING APPLICATION OF SIGNALING PRINCIPLES

4.1 *General*

The function of a signaling system, as noted previously, is to accept source information, convert it to appropriate signals for transmission over telephone lines or trunks and deliver it to its destination. The coordination of this function in a reliable and economical manner with switching and transmission system parameters constitutes the signaling problem. Criteria to be observed in the solution of the problem include speed, accuracy, efficient use of frequency spectrum, provision of adequate signal sensitivity and resistance to signal imitation and mutilation in the presence of noise and other transmission impairments.

The signaling principles outlined in the previous section have been evolved in the course of developing solutions to the signaling problem for various switching and transmission systems as they were conceived for the Bell System. Characteristics of particular switching and trans-

mission systems have in some instances emphasized certain of the principles and in other cases have limited their application. It is interesting to observe that the traditional distinction between "exchange" and "toll" signaling has probably resulted from varying and changing emphasis given to some of the factors next discussed. Parenthetically, it will be noted that this distinction is beginning to disappear, as direct distance dialing (DDD) and carrier-type transmission systems become more prevalent.

Section V of this paper contains descriptions of modern signaling systems as they are employed in the Bell System. The following discussion is intended to bridge the gap between the philosophical concepts discussed up to this point and the practical embodiments of signaling systems.

4.2 *Information Requirements*

Signals destined for customers at the ends of a telephone connection generally are conveyed in the form of audible tones — for example, dial tone, busy tone and ringing tones. These tones also provide information to operators. All other signals are of the type requiring machine recognition or response, and these are primarily of interest in considering the effect of information requirements on signaling systems. The general nature of this type of information is as follows:

- (a) information to *control* the seizure, holding or release of an inter-office trunk and the far-end equipment;
- (b) information to indicate to the originating end the *status* of equipment at the distant circuit terminal;
- (c) information describing the telephone number or telephone *address* of the called customer.

4.2.1 *Control*

Trunk *control* information may be manifested (or registered) by various electrical conditions in a telephone system. For example, the information may be registered by the position of a telephone switchhook, an operated key, a plug inserted in a jack or an operated relay in some part of a switching train (or by a memory cell in electronic systems). In common control systems, the control registration also exists during the addressing period in the device known as a sender.

The nature of the trunk control information is such as to be readily conveyed by a two-state signaling system, and Bell System signaling arrangements are designed to handle the function in this manner. Fur-

ther, the control information is capable of being transmitted continuously following this line of reasoning: let seizure be denoted by a change of state; then hold is a continuance of the state of seizure, with release a change of state in the opposite direction and idle a continuance of the state of release. This method may be contrasted with "spurt" signaling, wherein a change of state is indicated by a uniquely encoded signal of short duration for each state indicated. For simplicity and reliability, most Bell System signaling arrangements have employed the "continuous signaling" mode of operation, although, as shown later, continuous signaling is not applicable to transmission systems where trunk-to-channel concentrations are achieved through speech-interpolating arrangements.

4.2.2 *Status*

One purpose of *status* information is to indicate whether the called customer has answered or not. It is necessary to transmit this information to the originating end of a connection in order to indicate, for charging purposes, the start and end of the conversation time. The source of the information is the called customer's switchhook — either the telephone is off-hook or on-hook (similar information is also generated by the plug-in-jack response of a PBX operator answering a central office call).

As in the case of the control signals, status information indicating the answer condition can be readily conveyed by a two-state signaling system, and signaling systems in the Bell System are designed accordingly. However, in order to convey by two-state systems additional information relative to the status of the called customer's line, such as line or path busy, distinctive signals denoting these conditions are transmitted by coding the on-off intervals. It is interesting to observe in this connection that existing toll signaling systems have been designed so that busy information is conveyed by changes of state in the signaling system. This is done in order to flash an originating operator's supervisory lamp. However, with the trend toward DDD and away from operator-handled traffic, this requirement is being relaxed in new systems since such information can be satisfactorily conveyed to customers by audible tones on direct-dialed toll calls just as it is on direct-dialed exchange calls.

With common-control-type equipment at the terminating end of trunk circuits, additional status information is required to indicate the availability of the "sender" and its readiness to accept pulsing. In this case,

in order that the transmission from the originating to the terminating sender can be coordinated, status signals are returned from the terminating end to provide for "delay dial," "start dial," "stop dial" and "go." These status signals are also two-state in nature, at times being originated in the distant trunk relay equipment and at other times in the distant sender itself.

From the above it will be seen that the information source for both *control* and *status* signals occurs in various parts of a telephone system. The design of telephone switching systems is such that control and status information is usually registered or repeated in trunk equipments associated with each end of an interoffice circuit. The signal function is usually combined with the functions performed by these trunk equipments if a derived interoffice signal link is not required. This is illustrated by interoffice exchange trunks and toll-connecting trunks operating over DC trunk facilities. If, however, the transmission path requires derivation of a signaling link [such as composited (CX) or single-frequency (SF) links to be described later], it is not essential to combine the trunk or other information registers with the signaling link; in fact, it is usually better to separate the signaling link system so that it can be flexibly adapted to the trunk circuits of various switching systems.

4.2.3 *Address*

Let us turn now to the *address* function. The prime source of this information is the originating customer's dial. In nonsenderized step-by-step systems this source is usually repeated by a relay before being presented to the interoffice trunk conductors. Since the address generated by the dial consists of two-state signals, these can be conveyed through later stages of the switching system by any two-state signaling system.

In common control or senderized systems the address information generated by the originating customer's dial is registered on relays in the sender, and this constitutes the information source for subsequent signaling. It is possible to retransmit this source information in various ways, such as by dial pulsing, reverive, multifrequency or other techniques, (concerning which more will be said later). With the exception of dial pulsing, these read-out methods involve conversion to multistate signals. Thus, the effect of these arrangements is to require that ensuing signaling paths be capable of transmitting signals that are multistate in character.

From the above we may conclude that two-state signaling is adequate for all information requirements of nonsenderized systems and, in addition, is adequate for control and status signals of senderized type systems. Practical signaling systems have been designed with this in mind. For the transmission of address information by senderized systems, however, additional signaling capabilities are required. These are discussed in Section 4.4.

4.3 *Switching Systems*

The effect of switching system design on signaling systems is closely related to the effects just discussed. Nonsenderized step-by-step systems need to transmit only simple trunk control signals and trains of dial pulses in the forward* direction, sending status information in the backward direction. While the dial-pulsing function requires careful design and engineering to cope with the problems of pulse distortion and switch limitations, the signaling system as a whole is relatively simple. Common control switching systems increase the effectiveness with which information can be exchanged between switching offices. They also enlarge the opportunity to use improved signaling systems. However, they add considerably to the signaling system requirements.

The increased signaling possibilities of common control systems are obtained through the use of senders, which are digital storage and pulsing devices that can be temporarily associated with trunks and lines during the addressing process. They possess the capability of registering address information and transmitting and receiving this over trunk circuits in various ways. (Receiving-end senders are more appropriately called "registers" in the newer common control systems.) The use of senders in this manner has several effects on signaling systems:

(a) Full duplex signaling is required over the interoffice signal path in order that the sender control signals ("start" and "stop" dial, etc.) described in Section 4.2.1 can be effective.

(b) Full signal regeneration of the address is possible at each switching point.

(c) Higher-speed transmission is made possible.

(d) The addressing system can be separated from the trunk control and status indicating system.

(e) New signaling codes (or languages) can be introduced readily.

The significance of the first four effects noted above is obvious. The last-named effect warrants some further discussion.

* The term "forward" coincides with the direction of traffic over the trunk, the reverse direction being designated as "backward."

4.4 Signaling "Languages"

Signaling codes employed by senders in the Bell System for addressing or directing the positioning of switches include the following:

4.4.1 *Dial Pulsing*

Dial pulsing or decimal trains of pulses correspond to those produced by a rotary dial. Senders capable of decoding these pulse trains are used in all common control systems to record the number pulsed by the originating customer. Senders of the same general type, and also those capable of producing dial pulse trains, are required at common control offices when signaling to and from step-by-step systems. For engineering convenience, dial-pulse signals are sometimes used between common control offices. Some dial-pulse senders have been designed to operate at twice the nominal (ten pulses per second) dial speed, and signaling systems are affected accordingly. Otherwise, dial pulse simulation by senders has no effect on signaling systems except as noted in the previous general discussion on sender operation.

4.4.2 *Revertive Pulsing*

Revertive pulsing, the signaling language born of the panel switching system, is so named because of its reverse method of acting. Its principle of operation is broadly as follows: At the terminating end of a trunk a switch composed of a brush having access to a plurality of terminals is set in motion under its own power and is caused to leave a trail of pulses while seeking a terminal. These pulses are received by a sender at the originating end which compares the information they contain with previously stored digital information. When a match is obtained, the sender causes the switch to stop and close its contacts to the terminal at that position.* Information concerning the progress of the call from switch to switch is sometimes required by the sender, and this is transmitted in the same direction as the pulses just mentioned. Thus, the revertive system requires the transmission of three signaling states, two to define the digit pulses and a third for supervision. This has the effect of limiting revertive signaling to circuits specially designed for three-state operation. Up to recently, this has restricted revertive signaling to DC loops, and has prevented its application over derived two-state channels such as com-

* It is of interest to note that the revertive pulsing system represents an early method of accomplishing functions similar to those now performed by modern servo-control systems.

posite signaling, N carrier signaling and single-frequency signaling. However, as described in Section V, the latter has recently been adapted to three-state signaling for revertive pulsing.

Of interest is the fact that revertive pulsing is a substantially higher speed signaling system than dial pulsing. This follows from the fact that the pulses are not required to drive a switch, but are generated by a switch in motion. However, since the sender must tell the switch when to stop, and since this must occur on a terminal corresponding to the revertive pulse count, revertive operation introduces an additional "round trip" time requirement which must be met by the signaling system to keep the method operative. Although revertive is no longer the preferred method of pulsing for new systems, it might outlive the panel switching system, since it has been carried over into crossbar systems, where it presently serves to provide a common language between panel and crossbar and from crossbar to crossbar offices.

4.4.3 *Call Announcer and Call Indicator*

The introduction of dial switching systems into a manual telephone exchange network required that some method be provided to permit a machine office to complete calls to customers still served by switchboard operators. Two methods were devised to accomplish this. In the *call announcer* scheme the address digits were transformed in the machine office to spoken digits, which were then transmitted to the terminating switchboard operator. Another method caused the digital registrations to be transmitted to the terminating switchboard and there displayed as illuminated digits. The display method was called *call indicator*.

The call announcer method, utilizing a photoelectric digit-to-voice encoding machine, was quite ingenious but had limited application and is now practically nonexistent. It will therefore not be discussed further.

The call indicator method of signaling between dial and manual offices was applied both to the step-by-step systems and to the panel system. In the step-by-step system the signaling was done with conventional dial-pulse trains which were decoded and displayed at the switchboard. Since this involved no new signaling techniques, it is of no further interest in this discussion. However, in the panel system the signaling is of interest, since it was accomplished by a new multistate code. (The system is described in detail in Section V.) The *panel call*

indicator (PCI) code has an advantage in speed over dial pulse signaling; however, its multistate characteristics limit it to loop transmission paths capable of accepting multistate signals.

The PCI system has had a significant effect on signaling systems, far beyond its original display purpose. Since PCI senders were designed to transmit both the central office designation as well as the four numerical digits of the customer's number, they were utilized to transmit this information to tandem-switching-type offices when required. Crossbar system senders were also designed to follow suit, both with respect to call indicator operation as well as for operation with tandem offices. Thus, a considerable number of PCI signaling applications have resulted. However, PCI pulsing to manual offices will disappear with manual operation, and its use in signaling to tandem offices is being gradually superseded by multifrequency pulsing as crossbar and panel offices become converted to ten-digit dialing. For this reason, PCI signaling has not been included in the program of adapting exchange-type signaling to AC transmission over carrier systems.

4.4.4 Multifrequency

Multifrequency signaling is the most recent Bell System addressing language. Principally used at first as a signaling system for outward calls to the No. 4 toll switching system originating at DSA and CLR boards, and for inward call completion between manual and No. 4 toll switching systems and local crossbar offices, it was rapidly extended to permit distant toll operators to key-pulse calls also to the No. 4 system.

Multifrequency pulsing systems transmit each digit of an address with a single AC spurt. Each digit is composed of a unique combination of two out of a possible five frequencies in the voice band. In addition to the fundamental advantage of making it possible to signal over any voice channel, MF pulsing provides the advantage of being adaptable to operator key pulsing and high speed interoffice signaling. Through the design of its code, the received signals can be checked for parity and rejected if more or less than two frequencies are received for each digit.

Multifrequency pulsing is now standard for intertoll trunks between common control switching systems and for exchange trunks between No. 5 common control switching systems. Systems arranged to use incoming and outgoing multifrequency pulsing presently include the crossbar tandem system, the No. 5 crossbar system, and the No. 4 type

toll system. The No. 1 crossbar system is arranged for completion of terminating calls from offices equipped to send multifrequency pulsing. The older systems such as panel and step-by-step still depend upon their original methods of pulsing except that both panel and No. 1 crossbar systems are now capable of seven- and ten-digit multifrequency pulsing to tandem switching systems arranged for centralized AMA.

Multifrequency signaling, as indicated above, has had a considerable impact on the signaling arrangements used for switching systems. Its use is continuing to grow and new applications continue to be found. Systems based on the multifrequency pulsing objectives are now being considered for customer-to-central-office pushbutton signaling. In this connection, the use of a different coding system is being considered, but loss of compatibility may not be objectionable since, as noted earlier, the central office serves as a buffer between customer signaling systems and interoffice signaling systems.

4.5 Other Switching System Effects on Signaling

Returning now to the general matter of switching systems effects on signaling, we observe at least one other broad effect which is worth dwelling upon, i.e., one-way versus two-way operation of interoffice trunk circuits.

From the standpoint of traffic, it has been found satisfactory to operate with one-way trunk groups in exchange switching. In this method of operation, traffic always originates in the same direction over a trunk group. Trunk and signal circuits designed for one-way operation tend to be simpler than for two-way operation since they can be designed to fit only the signaling requirements that are unique to each end of the circuit.

Two-way operation has been the usual practice for long-haul or toll-type circuits in order that these costlier circuits can be used more efficiently. In practice, the additional signaling and trunk-switching complexity has been absorbed in the trunk equipment at each terminal, and the signaling arrangements have been kept simple by designing them for symmetrical operation at each terminal. With symmetrical operation, each of the input-output functions is applied, conveyed and delivered in an identical manner for each direction of operation. Since for the longer circuits the control and status functions are always conveyed over a derived signal link, such as CX or SF, and since these signaling functions have been reduced to two-state conditions in either direction it has been possible to design the signal links for symmetry without penalty.

4.6 *Effect of Special Signal Requirements on Signaling Systems*

The reader will note that these effects might have been considered in preceding sections. In electing to discuss them separately, we hope that there will perhaps be a little gain in clarity.

For the purpose of this discussion "special signal requirements" are considered to include such signaling functions as are not directly performed in conveying the basic information involved in trunk *control*, far-end *status* and called telephone *address*. Some special signals presently in use which are of interest are:

- (a) originating end re-ring (ring forward);
- (b) auxiliary charge functions;
- (c) interoffice coin (box) control;
- (d) calling party identification.

Of these, only the first directly affects the basic interoffice systems used for control and status. The remaining categories are conveyed by separate signaling systems which require only that they be mutually noninterfering.

4.6.1 *The Re-ring Function*

This is required only when an originating operator desires to attract the attention of a terminating operator after a connection has been established. It will be noted that this is never required on a direct customer-dialed call, either exchange or toll. And it is required on an operator dialed call only when the call cannot be directly dialed to the called customer. In this case an "inward operator" is called in at the terminating end to handle the call. The re-ring signal is a carry-over from manual ringdown practice, and will probably disappear when full DDD is in effect.*

The re-ring heritage goes back to the time when it was conveyed by a ringing signal which was the same whether used for connect, disconnect or re-ring. In carrying this function over to automatic signaling systems, it was integrated with the two-state systems which, it has been observed, are otherwise satisfactory for interoffice control and status requirements. This was accomplished by making use of time to derive a third state. Thus, to the basic connect and disconnect states, a third re-ring state, consisting of a short pulse of the disconnect state, was added. The effect of this is that signaling and switching systems must be designed with a proper regard for time, the signal system

* The re-ring function will be retained, however, for special operating assistance on dialed international calls, as discussed in Section VI.

being required to accurately sense and convey re-ring impulses, and the switching system being required to distinguish between short re-ring pulses and long disconnect signals. Obviously this requires close coordination between signaling system and switching system design, and it has been the basis of some interesting technical problems during the introductory coordination of new signaling systems with old switching systems.

4.6.2 *Remaining Special Signals*

We shall discuss these only briefly. Signals for charging purposes normally are conveyed by the called party answer and disconnect signals. These are interpreted in the originating switching office and result in the operation of registers or in records being made that correspond to the time of answer and disconnect on automatic message accounting tape. The primary effect on signaling systems of these charging systems is to make it quite essential that an answer signal be properly distinguished from a flashing signal, and this is done by appropriate timing in the trunk equipment at the originating switching office.

There exists in a few of the large metropolitan areas a system known as "remote control zone registration." In this, common equipment at a tandem switching point is used to generate a charge signal, depending on the destination of the call and the elapsed time of conversation. This information, consisting of a measured number of pulses, is transmitted from the tandem office back to the originating office where the customer's message register is operated. It is essential, of course, that this method be impervious to signal imitation by other signaling or switching functions. Hence, as applied in dc exchange signaling systems, the remote control signals consist of relatively high voltage pulses which are not readily imitated.

4.6.3 *Other Applications*

Some additional applications of the multifrequency system recently coming into use relate to the third and fourth categories of special signals noted above. In case (c), signal pulses similar to the digits in the multifrequency code are used to send "coin collect" or "coin return" signals from a master office to a satellite office not equipped with local coin supervisory equipment. In case (d), the identity of a line originating a call is transmitted using the multifrequency code from an originating switching office to an office equipped with centralized AMA recording equipment. These systems are chiefly of interest in this

discussion in illustrating the basic utility and versatility of the multi-frequency method of signaling. The primary impact of both of these systems on the interoffice signaling system is that they require careful coordination therewith. It is obvious that this is a fundamental rule that must be observed in considering the application of any new signal or signaling system to the telephone plant.

4.7 *Transmission Media*

The influence of the transmission media on the development of signaling systems has been at least as significant as that exerted by the switching considerations just discussed. The most significant impact, of course, is in the transition from simple metallic voice circuits, served by DC signaling, to repeatered or carrier-type facilities requiring AC signal transmission.

The DC signaling design problem has been somewhat similar to that encountered in the design of DC telegraph facilities. Signaling arrangements using both neutral and polar transmission have been employed in the design of trunk circuits operating over metallic facilities, with the choice being based on range requirements and economy. Where distances between central offices indicated the need for a higher degree of sophistication, other telegraph techniques were introduced in the form of simplex and composited signaling arrangements.

As dialing distances increased and the transmission path required the use of voice-frequency repeaters or carrier systems, it became necessary to either transmit the signaling information over paralleling DC telegraph facilities or by AC signals over the same path used for voice. The extensive use of carrier systems, in particular, dictated that AC signaling be employed.

Signaling systems using low frequencies, such as those used for early ringdown signaling systems, cannot be applied on circuits with composited telegraph. Also, low-frequency signaling systems are relatively slow in operation, due to lack of sensitivity and the need to protect the circuits from speech imitated signals. Even the 1000-cycle ringdown signaling arrangements, using 20 cycles as a modulating frequency, are too slow to be used for dial pulsing. Accordingly, AC signaling systems for dial operation required a new approach. In considering such systems the question is encountered whether to use frequencies within or outside of the voice band. Some of the advantages and disadvantages of the alternative schemes are reviewed below.

The obvious advantages of out-of-band signaling are, of course, free-

dom from the effects of speech currents, companders and echo suppressors. In general, out-of-band signaling also allows relatively simple terminal equipment and has the additional advantage of permitting signaling to take place during the talking interval. The necessity of providing additional bandwidth, filters to provide the signaling slot, and the possibility of switching to a trunk over which it is possible to signal but impossible to talk due to a trouble in the separate speech path, are disadvantages.

In-band signaling systems have the advantage of not requiring additional bandwidth. In addition, since the signaling currents utilize the same path as the speech currents, the amplification provided by voice amplifiers also renews the strength of the signaling currents. With in-band signaling it is possible to quickly substitute another voice channel in case of trouble, since the signaling is carried along with the speech circuit.

In-band signaling systems are advantageous when telephone facilities within a trunk are connected in tandem. Under these conditions signaling equipment need only be furnished at the terminals of the trunk and not at the intermediate point within the trunk. This is economically significant in the Bell System toll plant, where an average of 1.4 transmission links comprise a trunk. In addition to the economic advantage, there is no additional signal distortion introduced through equipment at intermediate points.

In-band signaling systems tend to be more complex because of the need for protection against speech-generated signals, but the Bell System type of in-band signaling provides protection adequately and economically by signal-to-guard arrangements in the signaling receiver. The guard uses the energy present in the frequency spectra outside of that assigned to the signaling frequency itself. Such guard energy, when combined with the energy present at the signaling frequency, determines whether the receiver is to operate or not. The ratio of signal-to-guard voltages can be adjusted at the time of design of the receiver, and this, together with timing, provides protection against speech operation.

In choosing the frequency to be used for supervisory signaling it is desirable to select as high a frequency as possible in order to reduce the occurrence of speech-imitated signals, since speech energies at the higher frequencies are, of course, a good deal less than those present in the lower ranges. In addition, it is desirable to select a frequency that will not interfere or be interfered with by signaling systems using other tones which may be present at the same time, such as multifrequency pulsing arrangements. The power level of the signaling frequency should also be low enough to avoid overloading the intermediate amplifiers, but it must

be of sufficient level to provide satisfactory operation of the receiver in the face of the usual types of noise present on telephone trunks.

The earliest in-band signaling system utilized a frequency of 1600 cycles. This frequency was dictated by the use of "emergency bank" carrier channels which were used during World War II to provide additional circuits. Trunks which included such filters had an upper frequency cutoff of about 1750 cycles, and hence a signaling frequency of 1600 cycles was selected. With the close of the war and the removal of the emergency equipment it was possible to raise the signaling frequency to 2600 cycles. At this higher frequency the problem of protection against speech operation was made considerably easier and permitted the use of smaller components as well as less complex circuitry. Present standard voice-frequency signaling systems employ tones of 1600 to 2600 cycles and use all frequencies, except the signaling frequency, to guard against false operation of the signaling receiver on speech currents.

Other AC signaling systems such as the multifrequency pulsing system must also be designed with the transmission media in mind. Falling in the band between 700 and 1700 cycles, they are just within the bandwidth provided by the emergency facilities and well within the voice band of standard voice circuits.

The most recent extension of AC signaling has been in connection with the exchange plant. With the continued trunk growth and increasing costs of voice-frequency cable facilities, the use of short-haul carrier systems appeared to offer economic advantages in the exchange plant over physical facilities. With the development of short-haul carrier systems arose the need for inexpensive signaling arrangements to handle the interoffice trunk signals.

Initially, two-state out-of-band signaling was employed using a signaling slot outside but adjacent to the voice band, and a system using 3700 cycles was designed for types N, O and ON carrier systems. While the signaling devices for this system were less expensive than in-band signal circuits, the system lacked the in-band advantages discussed earlier; also, the loss of circuit patching flexibility limited their usefulness somewhat. For these reasons, and in anticipation of the large-scale use of carrier in exchange areas, new transistorized in-band signaling arrangements were designed. The new in-band systems not only accommodated the two-state signaling required for control, status and dial pulse address signals, but also were adequate for the three-state reverting pulsing signals required by panel and some crossbar offices. In addition, the new designs were adapted to operation with a variety of switching system trunk circuits.

4.8 *Compatibility*

During the evolution of the Bell System plant it has been almost axiomatic that new systems should work with existing systems. This follows from the fact that it is difficult to justify economically the abandonment of existing plant in favor of permitting a new system to function in an environment all its own. Thus arises a problem in compatibility.

Prior to the widespread application of dial systems the compatibility problem was not severe, since intersystem signaling requirements for ringdown operation were relatively simple and dial system isolation was possible to a considerable degree. However, as the total number of dial central offices increased and, as the varieties increased, the compatibility problem became more important, particularly where direct dialing exchange areas were increased in size and scope. Finally, the introduction of nationwide dialing concepts caused the compatibility problem to become full blown.

Where the evolutionary developments in switching systems required that these systems communicate with each other, it was necessary to accomplish this over transmission facilities which also were undergoing evolutionary changes. It is obvious therefore that systems used for intersystem signaling have been faced with a sizable compatibility problem. In the solution to this problem it has been necessary also to make sure that signaling systems were properly coordinated with each other in order to avoid interference. Finally, the solution to the compatibility problem has required that the design of signaling systems adequately provide for flexible plant administration methods.

Up to about the beginning of the last decade, dial switching systems used for exchange service were interconnected over metallic paths and consequently employed dc signaling methods. Since, for operation over metallic facilities, the "control" and "status" functions are usually combined with the switching system trunk equipment, and since these equipments usually contained features unique to the switching system, there appeared to be little need for a systematic approach toward providing compatible signal circuits for interchangeable use between different switching systems. Consequently there resulted a large number of trunk circuit designs, many of which were uniquely tailored to a particular switching and signaling plan.

The extensive interconnection of different kinds of dial switching systems and the requirement for extending signaling ranges occurred at about the same time. Initially the extension in signaling ranges was obtained through the use of telegraph-type derived signal links which were

obtained by compositing the voice circuits. These signal links (CX) presented the opportunity for providing signaling compatibility. Thus resulted the standardization of input and output signals at the terminals of derived signal links. Output and input signaling leads, called somewhat arbitrarily E and M leads respectively, became standard terminations for CX signaling circuits and provided the capability of always delivering and accepting uniform signal conditions. This input-output standardization permitted CX signal links to be connected to corresponding E and M lead trunk circuits of any system. These standard terminations were carried over to the signal links later developed for use over nonmetallic facilities such as the various single-frequency signaling systems and out-of-band signaling systems.

As noted previously, the use of senders in common control offices has led to the use of a number of signaling languages for the address function — revertive, PCI and multifrequency. In order for systems to communicate with each other they have been equipped in varying degrees with registers and senders to accept these signaling languages. Table I shows the extent to which modern switching systems are able to address each other using the signaling languages. It will be noted that some systems have the ability to communicate in several ways with a particular connected system. The selection of a particular method is left to engineering choice, taking into account the total interconnecting requirements of the exchange or toll office under consideration.

The Bell System philosophy of repeating signaling information at each switching point has assisted in obtaining compatibility between various signaling systems, since at each switching point it is possible to convert the input control, status and address information to meet the requirements of the switching point beyond.

The problem of maintaining compatibility with transmission systems has involved conversion of interoffice signaling systems from DC to AC methods, where carrier transmission facilities were substituted for metallic facilities. With in-band signal system operation, proper coordination in the design of transmission and signaling systems has assured that satisfactory signal transmission will occur over any voice transmission system, and the standardization of input and output signaling leads for CX, SF and out-of-band signal links has made it possible to flexibly interconnect switching systems over DC or AC transmission facilities.

It is of interest to note the degree to which AC signaling systems must, of themselves, observe the rules of compatibility. Fig. 1 indicates the manner in which the voice-frequency spectrum is now utilized for the transmission of AC signals for telephone and other Bell System services.

TABLE I—ADDRESSING SYSTEMS BETWEEN OFFICES

Originating Office	Terminating Office									
	Step-by-Step	Step-by-Step Tandem	No. 4 Toll Crossbar	Crossbar Tandem	No. 1 Crossbar	No. 5 Crossbar	Panel	Office Selector Tandem	Panel Sender Tandem	Local Manual
Step-by-Step	DP	DP	DP	DP	DP	DP	X	X	X	V CI
Step-by-Step Tandem	DP	DP	DP	DP	DP	DP	X	X	X	V CI
Local Manual	DP	DP	DP MF	DP MF	DP MF	DP MF	DP	X	V	V
Dial System A	DP	DP	DP MF	DP MF RP	DP MF RP	DP MF RP	DP RP	RP	V PCI	V PCI
Manual Toll	DP	DP	DP MF	DP MF RP	MF RP	DP MF	RP	X	V	V
Panel Sender Tandem	DP	DP	X	X	DP RP	DP RP	RP	X	X	PCI
Crossbar Tandem	DP	DP	DP MF	MF RP	MF RP	DP MF RP	RP	X	X	V PCI
No. 4 Toll Crossbar	DP	DP	MF	DP MF	MF RP	DP MF RP	RP	X	X	V PCI
No. 5 Crossbar	DP	DP	MF	DP MF PCI	MF RP	DP MF RP	RP	X	PCI	V PCI
Panel	X	X	MF	MF PCI RP	MF RP	MF RP	RP	RP	PCI	PCI
No. 1 Crossbar	X	X	MF	MF PCI RP	MF RP	MF RP	RP	RP	PCI	PCI
Office Selector Tandem	X	X	X	X	RP	RP	RP	X	X	PCI

DP = Dial pulsing; RP = Revertive pulsing; MF = Multifrequency pulsing; PCI = Panel call indicator; CI = step-by-step call indicator; V = Verbal; X = No connection.

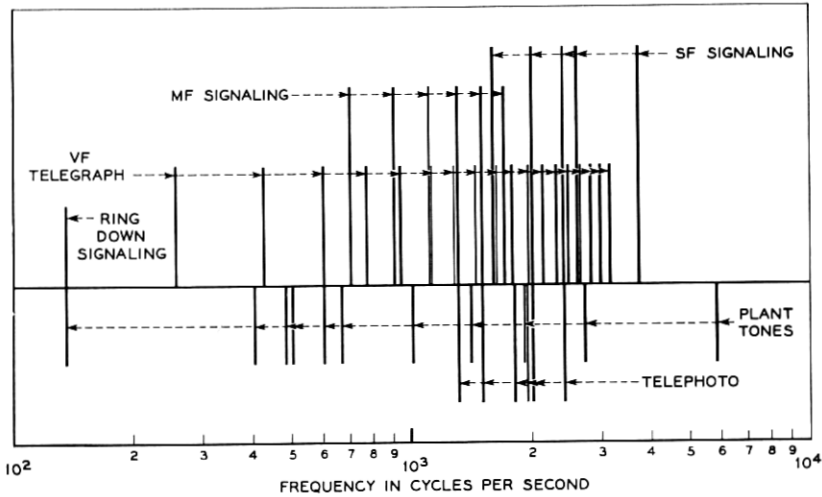

Fig. 1 — Various signaling and plant tones.

It is obvious that where any two or more of these signals are present at the same time it is essential that they be mutually noninterfering.

V. MODERN INTEROFFICE SIGNALING SYSTEMS

5.1 General

Up to this point we have discussed the nature and effect of signaling principles on the evolution of the signaling art. An idea of the methods of implementing these principles in practical signaling systems will be obtained from the following general descriptions. These are confined to typical systems and are divided broadly into two categories, DC signaling and AC signaling. In each category the performance of the trunk control, status and addressing functions will be observed, and also the application in the exchange and intertoll plant.

5.2 DC Systems

In the exchange plant where short distances are frequently encountered DC signaling systems continue to be used extensively. They are used also for some short-haul toll systems. The systems are of two general types, the simplest occurring where a DC loop path is available. These are grouped below as *loop signaling systems*. Where a clear loop path is not feasible or where extended DC ranges are desired, signal links

are derived from the transmission path as described under *derived signaling links*.

The loop and derived systems accomplish the trunk control functions (seizure, holding, release) and the status functions (far-end answer or other switchhook condition). In addition, the address function is coordinated with the loop signaling arrangements and conveyed directly by the derived signaling links when dial pulsing signals are required.

5.2.1 Loop Signaling Systems

These systems, in general, signal by altering the current flow in the trunk conductors. At one end of a trunk the current may be interrupted, its value changed between high and low levels, or its direction may be reversed. These changes are detected by sensitive, marginal or polar-type electromechanical relays at the other end of the trunk.

Signaling methods of this type have become known as *high-low*, *wet-dry*, *reverse-battery* and *battery-ground*. The older high-low and wet-dry methods are being rapidly supplanted by reverse-battery and battery-ground techniques.

5.2.1.1 *High-Low Signaling (Fig. 2)*. This method of signaling is accomplished by marginal current changes. A seizure signal is originated by applying battery and ground to the trunk in series with a marginal relay *c*. At the distant end, relay *L* operates and a call indication is given to the called office. When the called customer answers, the *s* relay operates to short-circuit the high resistance winding of the *L* relay, causing sufficient current to flow to operate the *c* relay to indicate the answer to the calling end of the trunk.

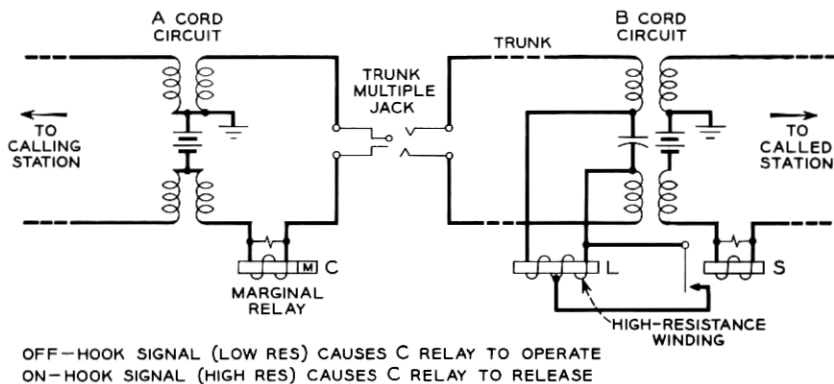

Fig. 2 — High-low signaling.

5.2.1.2 *Wet-Dry Signaling.* In this type of signaling a trunk is “wet” when battery and ground are connected to the called end of a trunk and a dc bridge is connected at the calling end to initiate a seizure signal. The customer answer removes the battery and ground, and hence the trunk is “dry” during the busy or off-hook condition and “wet” during the idle or on-hook interval. A release signal is registered by opening the dc bridge at the calling end of the trunk.

5.2.1.3 *Reverse-Battery Signaling (Fig. 3).* This is the preferred dc signaling system for modern interoffice exchange trunks. At the calling terminal a seizure signal is indicated by the closure of the trunk conductors through the windings of a polar relay cs. The resulting trunk current operates the A relay at the called terminal. Upon called customer answer the T relay is operated to reverse the polarity of the battery, which in turn operates the cs relay. A release is indicated by opening the trunk at the calling terminal.

5.2.1.4 *Battery and Ground Signaling.* A variation of reverse battery signaling is obtained by supplying battery and ground at each end of the trunk series aiding. This effectively doubles the value of the trunk current and permits increased operating range.

5.2.2 *Derived Signaling Links*

Derived signaling links are used for the longer exchange plant trunks and for short-haul intertoll trunks. Signaling connections between the trunk relay circuits and the derived signaling links are obtained via a uniform system of leads designated E and M. For this reason systems of this type are frequently known as E and M lead systems. Fig. 4 shows the interconnection between trunk and signaling circuits as well as the potentials and directions of the E and M lead controls. Fig. 5 shows further detail.

Several types of derived dc signaling circuits are in use as described below.

5.2.2.1 *Simplex (SX) Signaling (Fig. 6).* Simplex signaling feeds signaling currents through center taps of line transformers to the balanced path furnished by the trunk conductors. With SX signaling, the trunk resistance is halved by paralleling the two conductors, thus extending the range as compared to loop signaling.

5.2.2.2 *Composite (CX) Signaling (Figs. 7 and 8).* Composite signaling consists essentially of a high-pass-low-pass filter arrangement which separates the dc and low frequency signaling currents from the voice frequency signals, the separation point being at about 100 cycles per

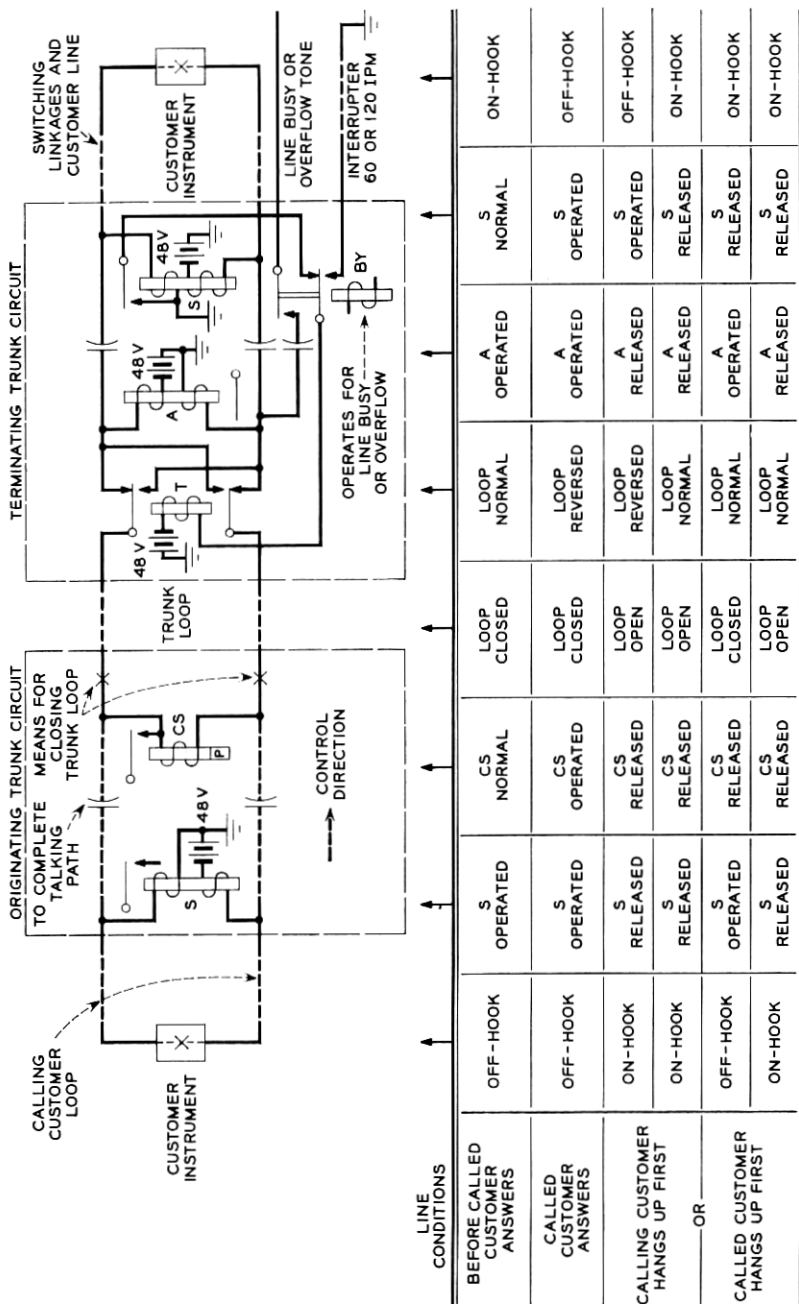

THE CS RELAY IS POLAR IN OPERATION BUT ALSO HAS MECHANICAL BIAS TO CAUSE RELEASE ON OPEN CIRCUIT

Fig. 3 — Reverse battery signaling.

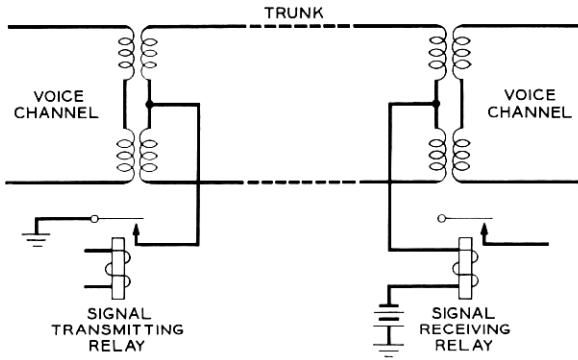

Fig. 6 — Principle of simplex signaling.

second. Fig. 7 shows the basic principles and Fig. 8 shows in greater detail the signaling arrangements for a single voice channel. The circuit uses one conductor of the pair for transmitting signaling information and the second conductor for providing compensation for ground potential differences between the two terminals.

When the trunk conductors of a phantom group are equipped with composite sets, four paths are obtained which can be used independently with a ground return or three paths with one path reserved for ground potential compensation for the other three paths.

5.2.2.3 *Duplex (DX) Signaling (Fig. 9).* Duplex signaling is based upon symmetrical and balanced circuit that is identical at both ends. It is patterned after composite signaling but does not require a composite set. One wire of the pair is used for signaling and the other conductor for ground potential compensation.

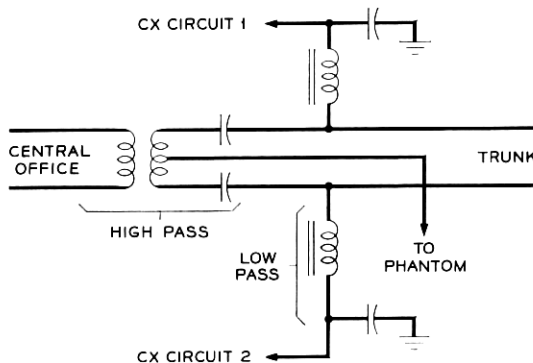

Fig. 7 — CX circuit for one end of a trunk pair.

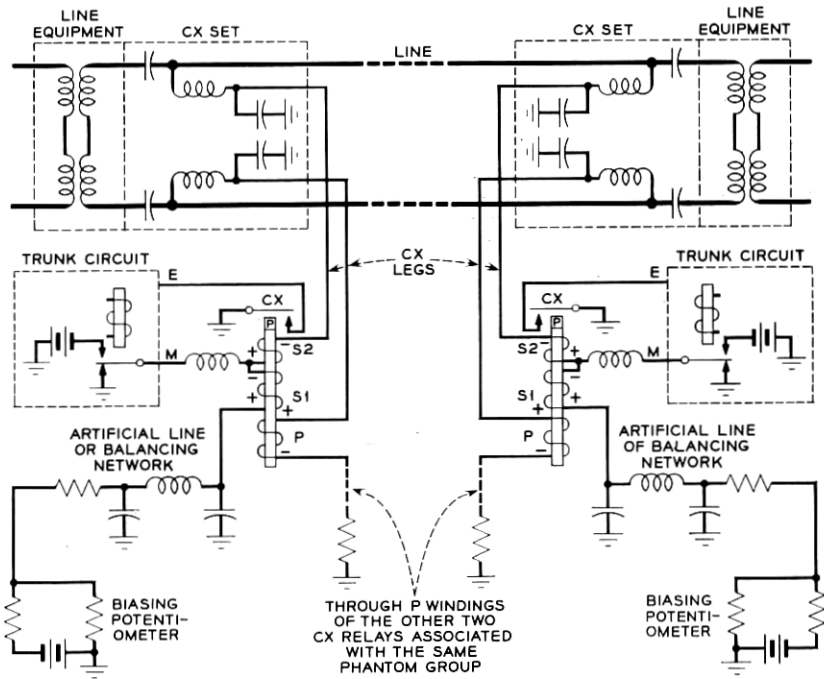

Fig. 8 — Composite signaling circuit for one-voice channel.

5.2.3 Addressing by DC Methods

5.2.3.1 Dial Pulsing. The customer's dial actuates a cam which generates open and close signals, the number of open or "break" signals being equal to the digit being transmitted. In common control switching systems dial pulses are generated by relay-type pulse generators.

Fig. 10 shows typical dial signals. Between digits the loop is closed for a somewhat longer time, which enables the switch in the central office to recognize the end of a digit.

Trains of dial pulses are defined in terms of pulse repetition rate and per cent break. (Per cent break is the ratio of the duration of a single open loop or "break" interval to the sum of the open and closed intervals.) Nominal speed values for all types of dials vary from 7.5 to 12 pulses per second; breaks vary from 58 to 67.5 per cent. The latest dials vary between 9 and 11 pulses per second and 60 to 64 per cent break. Some special operator dials are capable of 20 pulses per second, but these are only used with compatible central office equipment.

With loop signaling, dial pulses actuate a receiving relay, such as the

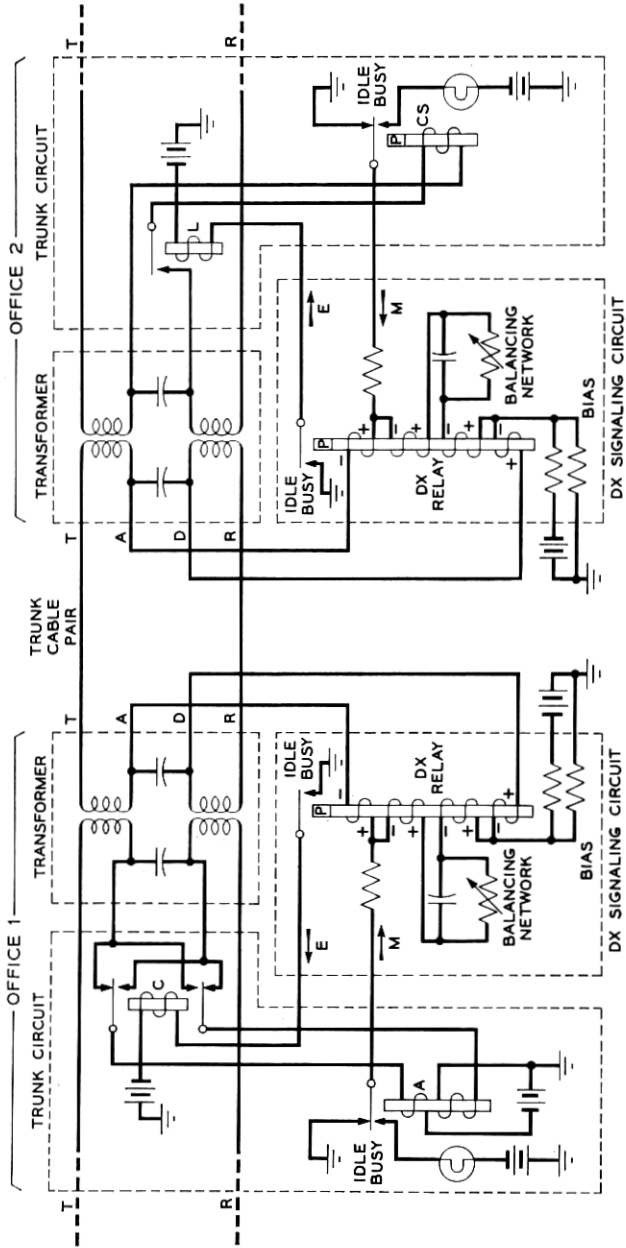

Fig. 9 — Duplex (DX) signaling.

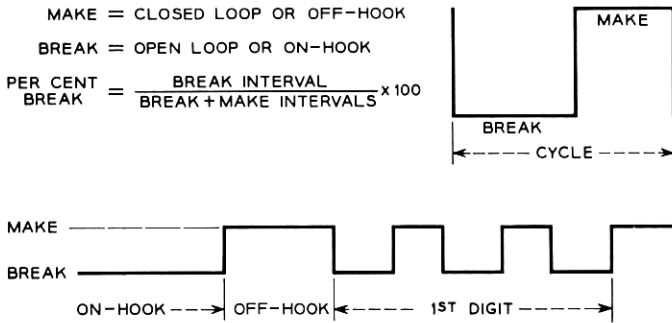

Fig. 10 — Signaling conditions during dialing.

s relay in Fig. 3. The operation of this relay either directly causes a switch to step or, in common control systems, the pulses are counted and registered by relays.

When using derived signal links, dial pulsing is transmitted in the forward direction via the M lead in the same way as the trunk control signals. Pulses are sent over the facility and result in similar pulses on the E lead of the terminating circuit. Through appropriate circuitry, the E lead pulses cause the terminating switch to step, as in the case of loop signaling circuits or, alternatively, the pulses are counted and registered by relays in common control systems.

The design of many of the E and M lead signaling circuits includes pulse correcting circuits to maintain the pulses within the operating limits of the associated central office equipment.

5.2.3.2 Revertive Pulse Signaling. As used in the panel system, Fig. 11, a “start” pulse from the originating office causes a terminating selector to be started and driven by its own power over a bank of terminals. The selector signals its position at each step by a pulse which is generated by a grounded brush passing over a commutator associated with the switch mechanism. A counter at the originating end of the trunk counts these pulses and initiates a signal to stop the switch when the desired position is reached.

When this is used in crossbar systems, a relay in the terminating office sender produces a train of revertive pulses upon receipt of a start signal from the originating office. The pulses are counted in both the originating and terminating offices. When a stop signal is received from the originating office, the count in the terminating office is transferred to a register, and the counter is released for use in the next digit.

Revertive pulsing is faster than dial pulsing, but requires signaling

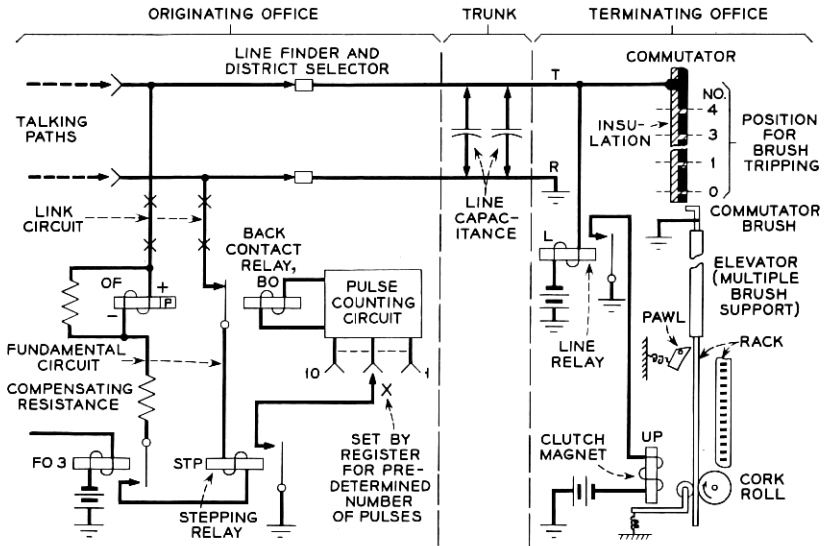

Fig. 11 — Retractive pulsing between panel offices.

circuits capable of operating up to 22 pulses per second from crossbar senders and up to 32 pulses per second from panel selectors.

The signals transmitted over the trunk conductors are shown in Fig. 12. Retractive signaling requires transmission of three states since, in addition to the two states required for the terminal count, a third state is transmitted after all selections have been pulsed. (This is referred to as “incoming advance” and signifies that the switching equipment can cut the trunk through to the talking paths at each end.) The three states are transmitted by two polarities and a zero current condition.

5.2.3.3 *Panel Call Indicator Signaling.* The PCI code is essentially a binary system employing four bits per decimal digit. The two states of

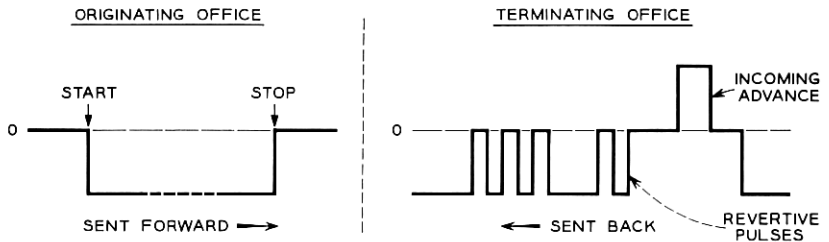

Fig. 12 — Retractive pulsing.

TABLE II—PCI SIGNAL CONDITIONS

Symbols	Loop Conditions			
—	open loop			
p	light positive current			
n	light negative current			
N	heavy negative current			
(Polarities are ring with respect to tip.)				
Basic PCI Cycle				
Time Intervals	A	B	C	D
Normal Pattern	—	n	—	n
Permissible Modifications	p	N	p	N

the first and third bits of each digit are defined by open and positive pulses with the states of the second and fourth bits being defined by light negative and heavy negative pulses. These variations are shown in Table II, and the complete code is given in Table III. The alternate negative bits of the code are used to synchronize the receiving with the sending end and to advance the register to successive digits. Four decimal digits, sent consecutively with no pause in between, require a total transmission time of about one second. The signal characteristic as it appears on the trunk conductors is shown in Fig. 13. A heavy positive pulse is transmitted to indicate end of pulsing. This, together with the four states required to define alternate bits of the code, results in a five-state signaling system.

As shown in Fig. 14, PCI pulses transmitted over the trunk are detected by means of polar and marginal relays at the receiving end.

TABLE III—PCI CODES

Digit	Hundreds Tens and Units				Thousands			
	A (1)	B (2)	C (4)	D (5)	A (2)	B (4)	C (8)	D (1)
0	—	n	—	n	—	n	—	n
1	p	n	—	n	—	n	—	N
2	—	N	—	n	p	n	—	n
3	p	N	—	n	p	n	—	N
4	—	n	p	n	—	N	—	n
5	—	n	—	N	—	N	—	N
6	p	n	—	N	p	N	—	n
7	—	N	—	N	p	N	—	N
8	p	N	—	N	—	n	p	n
9	—	n	p	N	—	n	p	N

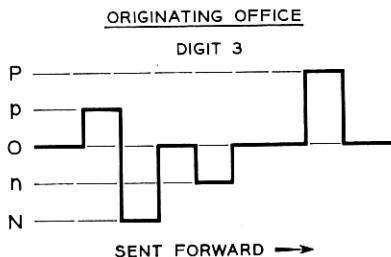

Fig. 13 — PCI pulsing.

The output of the detectors is registered on relays or switches in the terminating office. When the PCI transmission is to a manual office the registrations are displayed on a field of lamps in view of the operator. The display consists of ten numbered lamps for each digit, one of which is lighted to indicate the value of the digit.

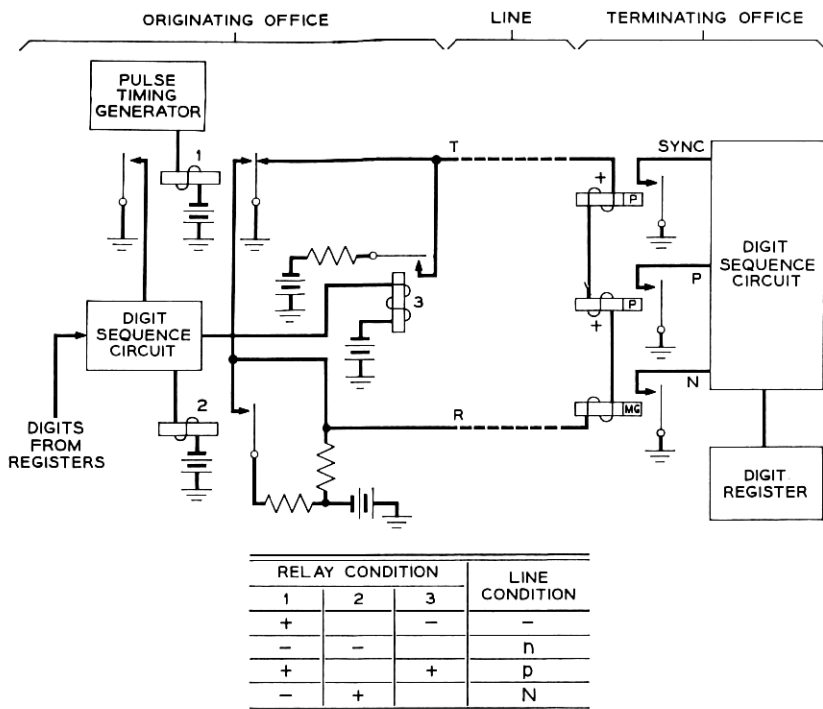

Fig. 14 — Basic PCI pulsing system.

5.3 AC Systems

5.3.1 General

Alternating-current signaling systems have been designed to convey the basic trunk control, status and address functions required by switching systems. They are used over toll and exchange trunks where dc signaling is not feasible or economical, such as long-haul circuits and short-haul circuits equipped with carrier. Two-state ac signaling can handle trunk control, status and addressing where the latter is coded by dial pulsing. Three-state ac signaling has been designed to handle the revertive method of addressing, including the trunk control and status signals. Multistate ac signaling, in the form of multi-frequency pulses, conveys the address function only. It is coordinated with two-state trunk control and status signaling, either ac or dc, as required.

In the two-state ac category, systems using both in-band and out-of-band signaling frequencies are in use. In-band systems are frequently referred to as *voice-frequency signaling*. They will be discussed first.

Voice-frequency signaling has a wide variety of applications. Frequencies in the voice band from about 500 cps to about 2,600 cps are used and signaling equipment is required only at the terminals of a long transmission path.

Voice-frequency signals are usually of the same order of amplitude as voice currents so as not to overload voice amplifiers or cause crosstalk in adjacent channels. Consequently, they cannot be detected by present-day electro-mechanical devices but must be detected by electron tube or transistor circuits.

One of the chief problems in voice-frequency signaling is prevention of mutual interference between voice and signals. Voice-frequency signals are audible and consequently signaling must not take place during the time the channel is used for conversation. Signal receiving equipment, however, must remain on a channel during conversation to be ready to respond to incoming signals and it may thus be subject to false operation from voice sounds which resemble the tones used for signaling. Protection against voice interference is accomplished in a number of ways:

1. Signal tones of a character not likely to occur in normal speech are chosen. In so-called 1000-cycle signaling, the frequency is modulated at a 20-cps rate. In multifrequency systems, several frequencies are combined and individual receivers set up to respond to each frequency.

2. Time delay is often used to prevent false operation due to voice. The signal receiver is made slow to respond so that normal noise and voice currents which would otherwise actuate the receiver are ignored.

3. Voice-frequency energy, other than the signaling frequency, is detected and used to inhibit the operation of the signaling receiver.

First single-frequency (SF) circuits used 1600 or 2000 cycles for signaling frequencies, while the latest circuits use 2400 or 2600 cycles. Since these frequencies are in the voice band they can be passed over the line facility with the same ease as voice currents.

The SF signaling system is designed to pass the necessary signals for telephone trunks over voice frequency transmission line facilities without impairing the normal use of these facilities for speech. This system accepts and delivers DC signals from the switching trunk equipment. The DC signals are transformed to AC forms on the line side, and vice versa. The same frequency is employed in both directions on four-wire line facilities, since these have separate transmission paths between terminals. On two-wire facilities, different frequencies are used in the two directions. One signal frequency is applied or removed at each end of a line facility to operate or release a relay at the far end. In this way, two alternate signal conditions are provided in both directions of transmission. Normally, speech and signal frequency are not on the line facility at the same time.

The SF signaling circuit is inserted in series with separate transmitting and receiving branches, that is, the four-wire transmission points at the terminals of line facilities. The office side of the transmitting branch may be opened momentarily for critical signaling conditions, but the receiving branch is provided with continuous, one-way transmission. These features protect the signaling circuits from noise and tones originating on the office sides of each terminal.

Relatively high signal power of short duration is used for effective operation in the presence of greater than normal line noise. The guard-channel principle is employed to avoid false operation by signal frequencies present in speech or music to which the receiver is exposed because of continuous association with the line. The guard channel uses frequencies outside the signal frequency band to oppose the operating effect of the signal frequency. In addition, this system inserts narrow-band elimination networks centered on the signal frequency in the voice path to limit the effect of signal power when this is present on the line. These networks are switched out at all other times.

5.3.2 *In-Band SF Signaling (Intertoll Applications)*

Fig. 15 is a photograph of the latest transistorized SF signaling unit (for intertoll trunks) in the Bell System. For comparison purposes, Fig. 16 shows the earlier electron tube model. Occupying one-third of

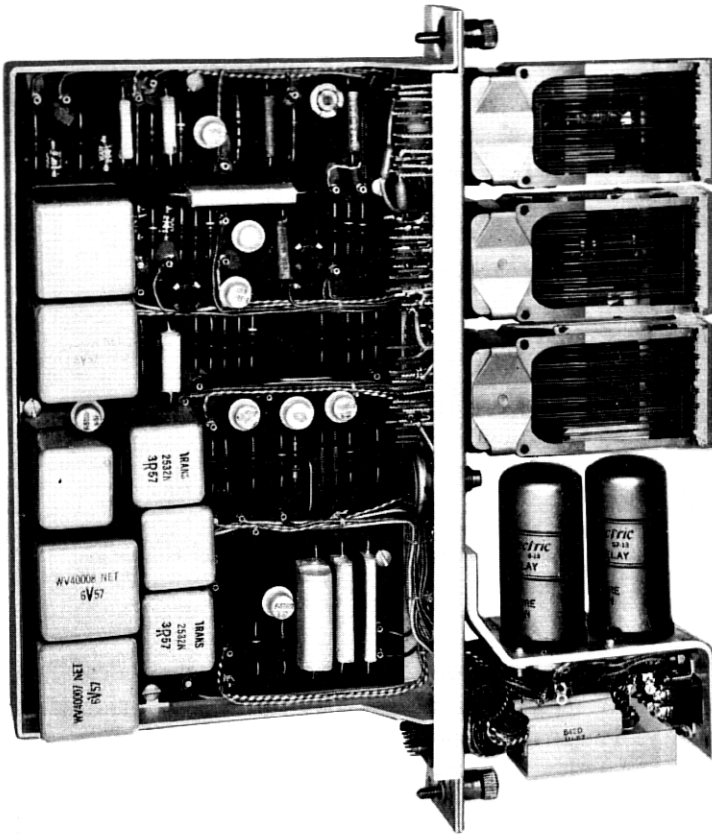

Fig. 15 — The E2B SF signaling unit.

the space and using one-third the power of its electron tube predecessors, the transistorized model employs miniaturized components, printed wired cards and appropriate solid state circuitry and techniques. Wire-spring relays are used where economics dictated their choice. The wedding of new and old concepts is proving to be a most happy match.

Fig. 17 indicates in block diagram form the more important features of the SF signaling unit. On the office side, six leads interconnect the signaling unit and associated trunk relay circuit, the E and M leads for signaling and the send and receive voice circuits of the signaling unit and the associated four-wire branches of the line facility, generally a carrier telephone system.

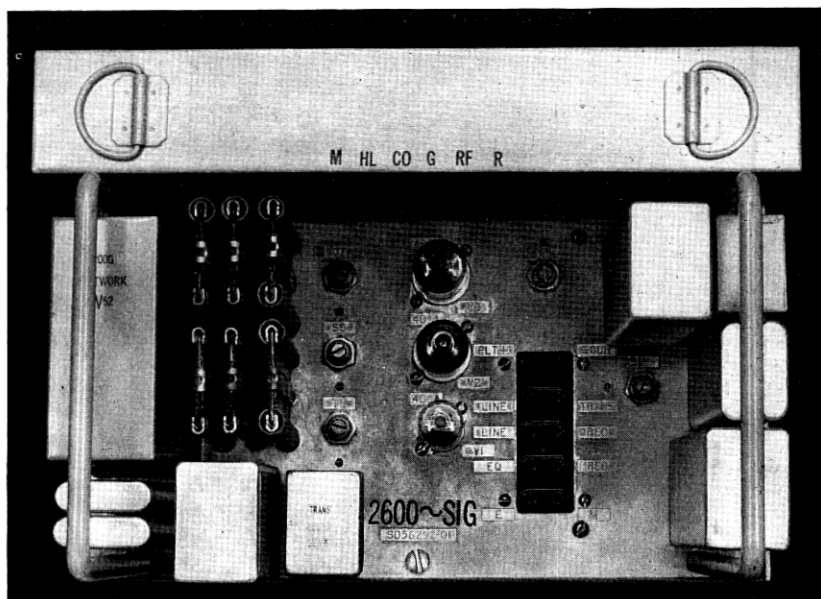

Fig. 16 — 2600-cycle SF unit (electron tubes).

The keyer relay *M* operates and releases from signals on the *M* lead and alternately removes or applies 2600 cycles to the transmit line of the facility. The *M* relay operates the high-level relay *HL* to remove a 12-db pad in order to permit a high level initial signal to secure an improved "signal-to-noise" operating environment. The *HL* relay is slow to release and hence dial pulses, which operate the *M* relay, are transmitted at an augmented level. In addition a cutoff relay, *CO*, operates to short-circuit any noise which may be present from the office side of the circuit. A bridged retardation coil with center-point grounded is also provided to drain off longitudinal currents that may arise in the office equipment and possibly interfere with signaling. The *M* lead will accept and the SF unit will transmit dial pulses at speeds from 8 to 12 pulses per second with per cent breaks ranging from 46 to 76 per cent.

The receiving portions of the SF unit include a voice amplifier, appropriate band elimination networks, and a signal detection circuit. The voice amplifier's primary function is to block any noise or speech present in the office equipment from interfering with the operation of the signal detector and also to make up for the insertion loss of the SF unit in the receive speech path.

To understand the signaling unit operation, assume that a trunk equipped with 2600-cycle SF units is in the idle condition. A 2600-cycle tone (-20 dbm referred to the zero transmission level point, 0 db TL) is present in both directions of transmission.

A seizure signal originating at one terminal results in a change in state on the originating M lead from ground to battery. As a result, the keyer relay M operates and removes 2600-cycle tone from the sending line. The loss of tone is detected at the distant SF signaling unit and the resulting action changes the E lead from an open to a ground condition. The grounded E lead results in a request for connection of an incoming register or sender. Since there may be a slight delay in securing a register, the trunk circuit changes the M lead state at the terminating office from ground to battery, resulting in the removal of 2600-cycle tone from the line facility, from the terminating to the originating office. This results in a signal on the originating office E lead to delay the transmission of the address information.

When an incoming register is connected, the terminating trunk circuit restores ground to the M lead of the SF unit, and 2600-cycle tone is reapplied to the line. At the originating terminal the reapplied tone is detected and the resulting E lead signal indicates that pulsing of the address information can begin.

If dial pulsing is used for addressing, the M keyer relay is operated and released in accordance with the dial pulses being transmitted. This results in pulses of 2600-cycle tone, one for each dial pulse, at an augmented level. Interdigital intervals of 0.6 second are inserted between dial pulse trains when transmission is from an outgoing sender.

At the end of pulsing, 2600-cycle tone is removed from the line in the forward direction but tone is still being received from the distant terminal. When the called customer answers, the action of lifting his receiver results in a signal from the terminal trunk circuit to the SF unit, and tone is removed in the backward direction. For the talking interval there are then no tones present in either direction and no band-restricting components present.

On calls for which no charges are made, such as business office, repair or service calls, the tone in the backward direction is not removed, but a band-elimination filter prevents the tone from reaching the calling customer. The transmission path has, of course, been slightly degraded by the introduction of the filter but this is not considered serious on this type of call. On transmission systems equipped with companders the presence of the backward-going tone may reduce the compandor cross-talk and noise advantage.

5.3.3 Out-of-Band SF Signaling (Intertoll and Exchange Applications)

Certain carrier systems include built-in signaling equipment (Types N, O, and ON) using a separate frequency slot outside of but adjacent to the voice band. In the Bell System a frequency of 3700 cycles is used for such signaling systems. Fig. 18 outlines the basic features.

During the trunk-idle condition the 3700-cycle frequency is present in both directions of transmission and trunk control and status signals are transmitted by interrupting the tone in similar fashion to that already described for in-band SF systems. Since the signaling path is outside of the voice band no provision is required for protection against voice operation. In addition, companders are not affected by the tone, and signaling, if required, can take place during the talking condition.

The out-of-band system in use at the present time provides only for E and M connections to associated trunk circuits. Circuits have been

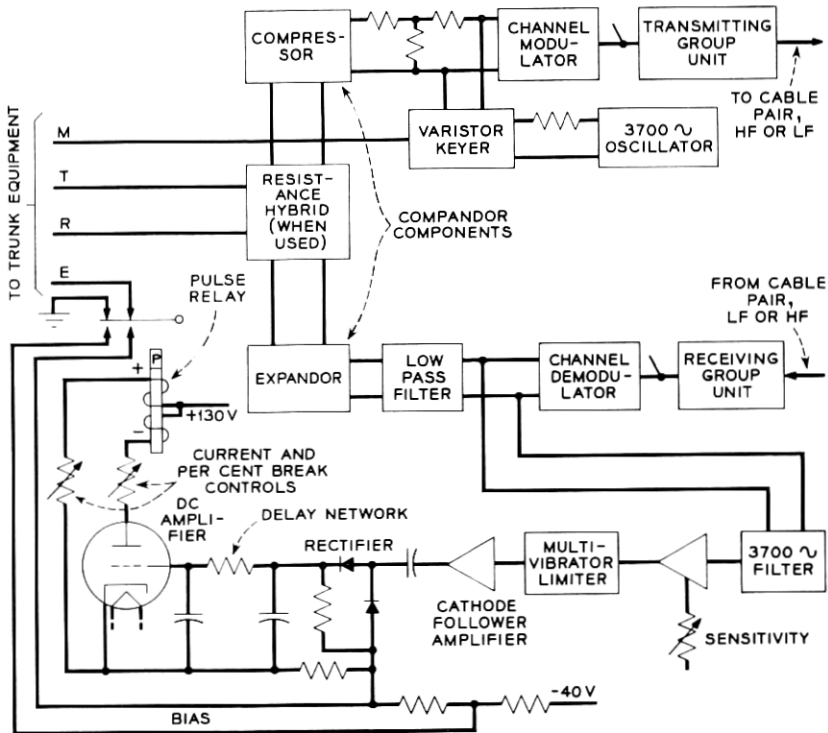

Fig. 18 — N-1 carrier signaling system (out-of-band).

designed for converting E and M lead signals to loop signals when required.

5.3.4 In-Band SF Signaling; Revertive Pulsing (Exchange Applications)

For application in the exchange plant a new series of transistorized signaling units makes it possible to adapt loop signaling trunks to short haul carrier systems. The SF units provide loop-signaling-reverse-battery supervision toward central office switching equipment and in-band AC signaling toward the line. These units also include the four-wire terminating sets required for converting between the four-wire line facility and the two-wire loop. The terminating sets are suitable from a transmission standpoint for exchange, tandem and toll-connecting trunks.

Since revertive pulsing, as indicated earlier, is a three-state signaling system, a brief description of its adaptation to AC signaling will be of interest. Such trunks are one-way circuits and hence the functions of the revertive signaling units at the two terminals differ. An over-all trunk layout is shown in block diagram form in Fig. 19. Figs. 20 and 21 detail the major functions included in the signaling units at the originating and terminating ends of the trunk.

The originating terminal includes two receiving circuits: one a 2600-cycle receiver, to detect trunk status signals, the other a 2000-cycle

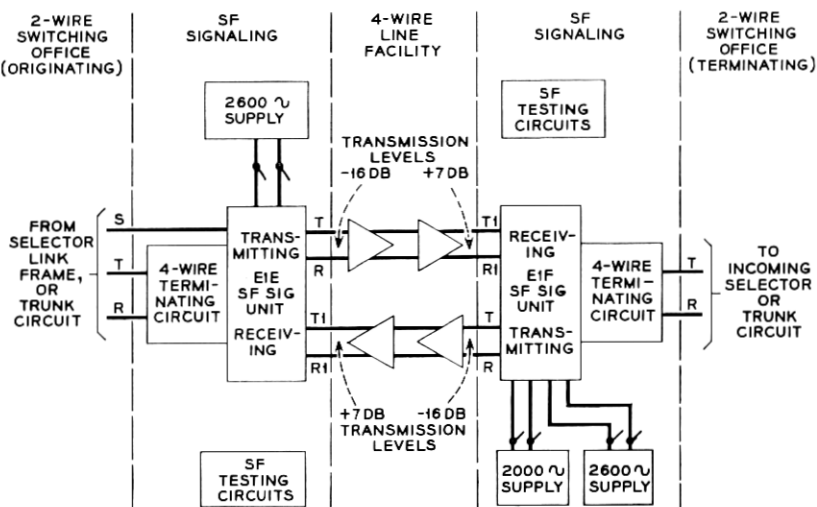

Fig. 19 — Circuit layout using SF signaling unit for revertive pulsing.

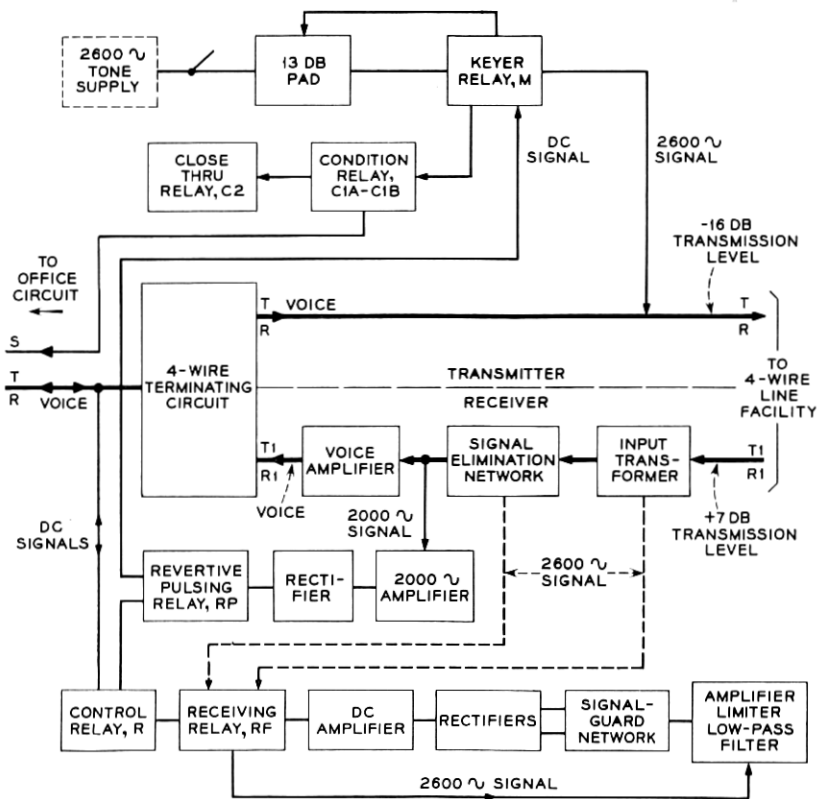

Fig. 20 — Basic elements of SF signaling unit — originating terminal reverive pulsing.

receiver, to detect the reverive pulses. At the terminating end of the trunk only a 2600-cycle receiver is required to detect trunk control signals but two transmitters are provided. The reverive pulses are transmitted by keying a 2000-cycle oscillator, while the trunk status signals key a 2600-cycle oscillator.

The bandwidth of the 2000-cycle channel for the reverive pulses is quite wide in order to accomodate the high-speed signals. As indicated earlier, pulsing speeds up to 32 pulses per second are used. Because of the wider bandwidth, care must be exercised to prevent extraneous circuit transients from appearing as legitimate pulses. Another requirement for reverive pulsing circuits is the need for fast round-trip transmission times. Since the reverive pulses are generated at the terminating end of the trunk and are detected and counted at the originating

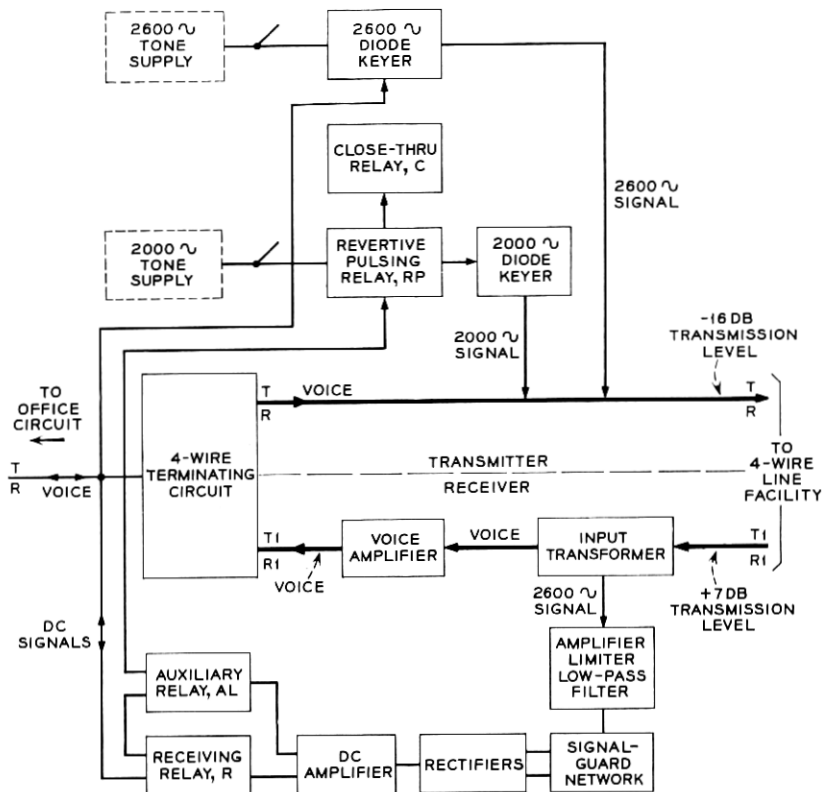

Fig. 21 — Basic elements of SF signaling unit — terminating terminal reverberative pulsing.

terminal, a signal to stop the panel office elevator at the terminating end must be transmitted as soon as the counting circuit at the originating end is satisfied.

5.3.5 Multifrequency Pulsing (MF)

Multifrequency pulsing accomplishes the address function with AC signals, in both the toll and exchange plant. This system transmits digits by combinations of two, and only two, of five frequencies. Additional signals are provided by combinations using a sixth frequency. Table IV shows the multifrequency codes. The six frequencies are spaced 200 cycles apart, from 700 to 1700 cycles inclusive. Each combination of two frequencies represents a pulse, and each pulse represents a digit.

The pulses are sent over the regular talking channels and, since they are in the voice range, are transmitted as readily as speech. There are fifteen pairs of frequencies possible from the group of six; ten of them for the digits 0 to 9, inclusive, and one each for signals indicating the beginning and end of pulsing. The remaining three possible pairs are available for special requirements.

The multifrequency system is arranged so that, if more than two frequencies are detected by the receiving equipment, a reorder signal is returned.

The multifrequency pulsing system consists of:

(a) signaling current supply units and distribution arrangements with suitable protection and alarm features;

(b) signal transmitters, either manual multifrequency keysets or dial system multifrequency outputting senders;

(c) signal receiver connected to the incoming sender or register.

One arrangement of the system components for pulsing on a trunk between manual and dial system offices is shown in Fig. 22. A local manual or dial system or toll switchboard equipped with multifrequency key pulsing is shown connected by a direct trunk arranged for multifrequency pulsing to a crossbar office equipped with incoming multifrequency pulsing senders.

The first signal transmitted by the operator is a gate opening signal call a KP signal. Receipt of the KP signal at the distant end prepares the multifrequency receiver to accept the digits that are to follow. The operator begins sending the address digits by pressing one button for each digit. Following the last digit, she presses the ST button to indicate the end of pulsing. In addition to informing the distant sender that no more pulsing signals are coming, the operation of the ST key disconnects

TABLE IV — FREQUENCIES AND DIGIT CODES FOR MF PULSING

Digit	Code	Frequencies
1	0 + 1	700 + 900
2	0 + 2	700 + 1100
3	1 + 2	900 + 1100
4	0 + 4	700 + 1300
5	1 + 4	900 + 1300
6	2 + 4	1100 + 1300
7	0 + 7	700 + 1500
8	1 + 7	900 + 1500
9	2 + 7	1100 + 1500
0	4 + 7	1300 + 1500
KP	2 + 10	1100 + 1700
ST	7 + 10	1500 + 1700

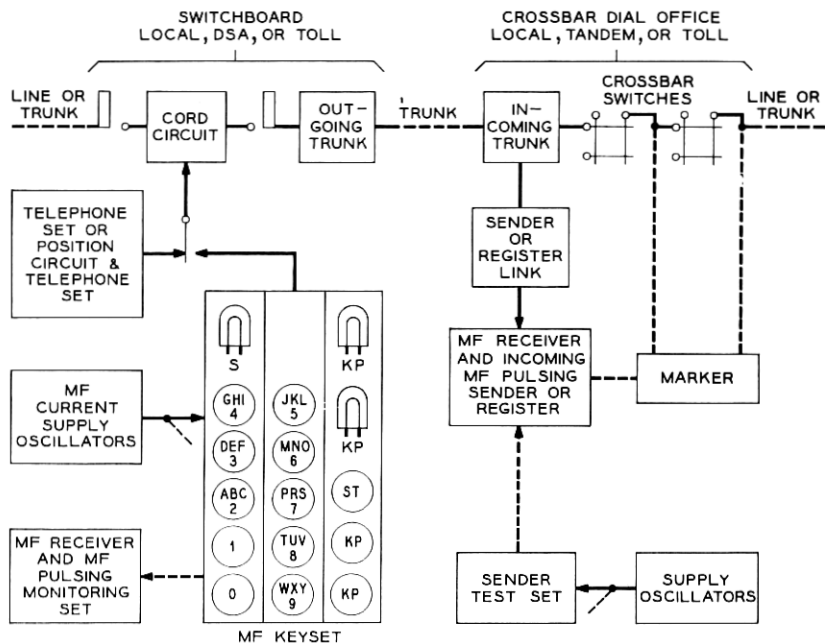

Fig. 22 — Plan of MF pulsing system.

the keyset from the cord, reconnects the telephone set under control of the talk key and extinguishes the KP and sender lamps.

If the operator inadvertently presses two buttons simultaneously, the MF receiver at the distant terminal will detect a variation from the two-out-of-six pattern, and a reorder signal is transmitted by the distant end. Given this information, the operator releases the connection and starts the call again. Fig. 23 shows a typical MF receiver plan.

When the receiver is in the pulsing condition the two signal frequencies applied to the input are amplified or limited depending upon the received signal power. The frequencies are selected by two appropriate channel filters and detected. The rectified voltages in turn fire hot-cathode gas tubes and in turn operate two channel relays. The channel relays when operated will ground two out of five leads to the incoming sender register circuit. When the received signal is ended, the signal present circuit of the receiver will indicate the end of the pulse to the register circuit, permitting the register to advance to the next register bank awaiting receipt of the next digit. Fig. 24 shows a multifrequency receiver equipment unit.

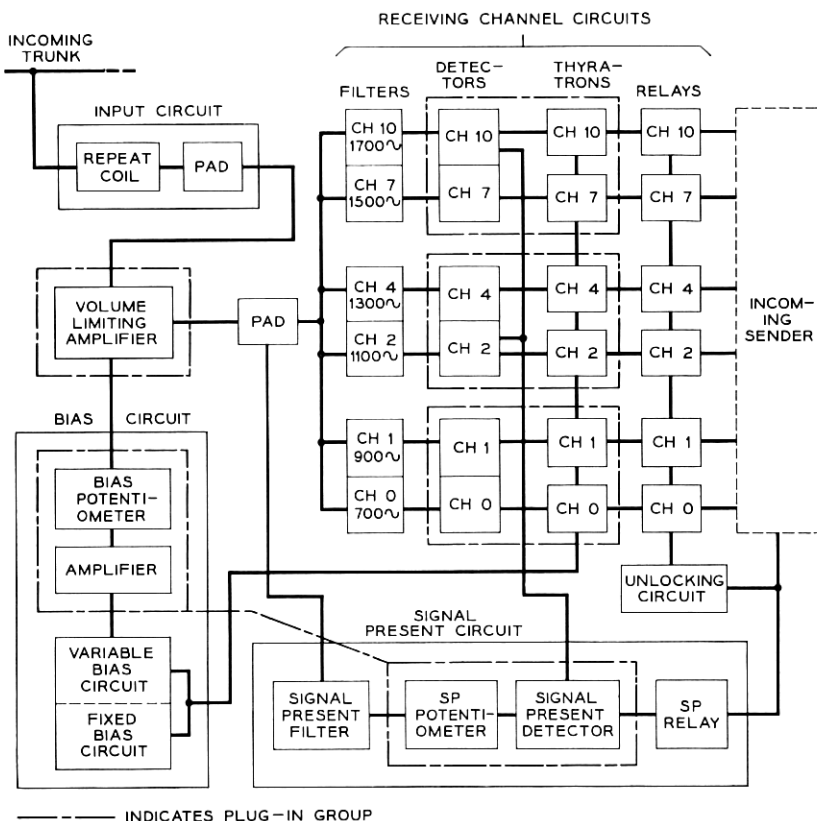

Fig. 23 — MF receiver plan.

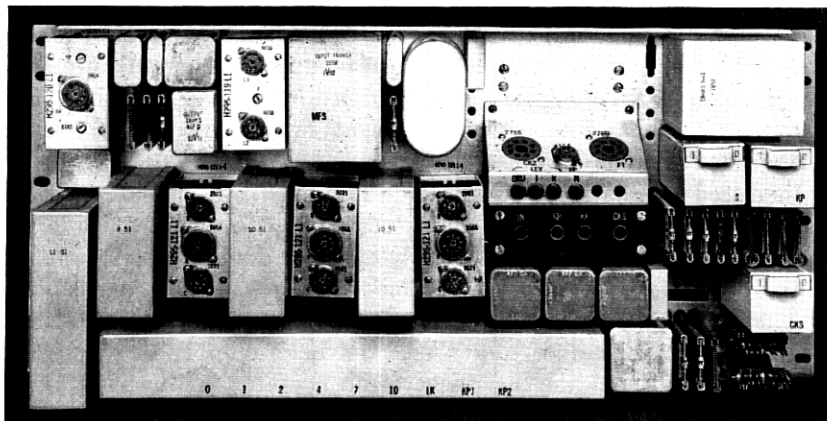

Fig. 24 — Multifrequency receiver unit.

VI. CONSIDERATIONS INVOLVED IN INTERNATIONAL SIGNALING

The extension of dial service to the United Kingdom and Europe introduces some interesting new signaling problems. Arising principally from the fact that there are some important differences between the switching philosophy and signaling techniques of the British and European telephone systems as compared to those of the telephone systems in this country, the signaling problem is further complicated by unique requirements imposed by new transmission systems. As has been noted in previous sections, such factors, while influencing the form of signaling systems during the evolution of telephone facilities in this country, have been subject to reasonably close coordination. However, up to recently there has been no need for coordination between North American systems and those used in Europe. Since the latter have independently reached an advanced state of the art, it is not surprising that rather complicated signaling problems now arise in attempting to convey switching information between hemispheres. These problems are reviewed below, together with the solutions that are being evolved.

International traffic over radio systems and submarine cables is at present handled by switchboard operators stationed at the circuit terminals. Transatlantic traffic presently employs "ringdown" operation; that is, an operator wishing to connect a calling customer to an international point signals an operator at the distant terminal by applying a ringing signal. The originating operator passes the wanted number verbally and the terminating operator completes the connection to the called customer. At the end of the call the originating operator again rings the receiving terminal and both operators pull down their connections. The signal used for ringdown operation from North America to Europe is a 500-cycle tone modulated by a 20-cycle tone; for calls from Europe to North America a 1000-cycle tone modulated by 20 cycles is used. Thus it can be seen that the international signaling function with ringdown operation is relatively simple.

Increased international business and improved transmission facilities have stimulated an increase in overseas telephone traffic. In order to utilize existing trunks more efficiently operator dialing is being applied initially to international circuits. There is the possibility of customer dialing at a later date. In this first step toward improved operations the originating operator dials the called customer's number to set up the call directly without the assistance of an operator in the terminating country. This type of operation is now in service between the U.S. mainland and Hawaii and Alaska, with operators dialing over radio

circuits as well as submarine cables. More recently, it has been applied to circuits between the mainland and Puerto Rico.

Dialing to European countries raises problems of compatibility between switching systems, signaling systems and operating techniques. The basic objectives of conveying information for trunk control, status information and addressing are the same for circuits connecting the United States with other countries as they are for circuits within the United States, but differences in signaling and switching philosophies create areas where compromises are necessary in the intersystem signaling arrangements. These differences are discussed below.

6.1 *New Information Requirements*

United Kingdom and European practices require that additional information be encoded, transmitted and interpreted by the associated signaling systems, as follows:

6.1.1 *Terminal and Transit-Seize Signals*

These signals are coded connect or seizure signals to indicate whether the incoming call should terminate in or switch through the country. In the Bell System such information is decoded by the switching system from address data.

6.1.2 *Language Signals*

These are digit signals (one through nine) indicating the service language which must be used when assistance operators are called in on the connection. This digit precedes the address information and is stored in the incoming relay or trunk circuit. When a ring-forward signal is received from the originating terminal, the stored language digit together with the operator selection signal will determine the operator to be called in on the connection. Such signals are not required in the Bell System.

6.1.3 *Acknowledgment Signals*

1. *Terminal and transit "proceed-to-send" signals* are used to indicate that the proper register is attached and ready to receive digits. The equivalent in the Bell System is the "start-dial" signal, except that only one signal is required.

2. *Digit reception acknowledgment signals* are used to inform the originating register that each individual digit has been received and that

transmission of the next digit can start. Digit acknowledgment signals are not used in the Bell System.

3. *Number-received signal* is a signal to indicate reception of the complete address. This signal is not required in the Bell System.

4. *Release-guard signal* is transmitted to the originating terminal to indicate that the clear-forward (disconnect) signal has been fully effective at the incoming end. It serves to protect the circuit from reseizure before the circuit has been completely disconnected. In the Bell System this protection is provided by timing arrangements at each terminal and no special signal is required.

6.1.4 *Operator Selection Signals*

Assistance operators handling European international telephone calls are designated as "Code 11" or "Code 12" operators. These operators are called in by transmission of distinctive signals and they perform the following services. A "Code 11" operator is an assistance operator who performs the usual functions of an incoming operator in manual service. A "Code 12" operator is a delayed-ticketing or suspended-call operator. When a particular "Code 12" operator is desired a call number is added and follows the "Code 12" signal.

6.1.5 *Typical Call*

To illustrate the use of these signals assume a call originated at London for Rome via Paris and Frankfurt. The initial seizure signal will be transmitted from the outgoing register in London to the incoming circuit in Paris as a "transit seize" signal. This signal will cause a "transit" register to be attached at Paris. When the register is ready to receive information a "transit-proceed-to-send" signal is returned to London. London will then transmit the country code digits representing the country of destination. The reception of this information at Paris will cause the register to return an acknowledgment of the digits to London and select a circuit to Frankfurt. A "transit-seize" signal is now transmitted by the Paris register to the Frankfurt terminal, and the speech path is closed through and the Paris register is dismissed.

The Frankfurt register, when connected, will return a "transit-proceed-to-send" signal to London, and London again transmits the country code digits. The Frankfurt register acknowledges reception of the country code, selects a route to Rome, transmits a "terminal-seize" signal to Rome, closes through the speech path and releases.

At Rome a terminal register is connected and a "terminal-proceed-to-

send" signal returned to London. The outgoing register in London now transmits a language digit and the national number of the called customer, followed by an "end-of-pulsing" signal. Each digit transmitted from London to Rome is acknowledged by transmission of a signal from Rome to London and, when the complete address has been received, the Rome register returns a "number-received" signal to the London operator. The outgoing register in London is dismissed and the speech path closed through after the "end-of-pulsing" signal is transmitted.

At the end of the call the connections are released at each switching center by disconnect and release guard signals transmitted in turn from Rome to Frankfurt, Frankfurt to Paris, and finally Paris to London.

The type of signaling described above is often referred to as "end-to-end" signaling. In contrast to this method the Bell System employs "point-to-point" signaling. In the latter all of the information concerning a call is transmitted from the originating point to the succeeding switching center, following which the sender at the originating point is dismissed to handle other calls. Signals are not transmitted between intertoll switching centers to acknowledge reception of the address information. Where calls require switching through several centers the address information includes an area code directing the call to the proper destination and when the final trunk is selected the area code information is dropped and only the customer's local address transmitted.

Point-to-point signaling results in reduced holding time for originating office senders, permits the use of different signaling and pulsing systems on each of the trunks comprising the complete connection (hence increased flexibility), and provides a transmission advantage since the signals are regenerated at each switching point. Hence, signaling arrangements for each trunk need only operate in the environment of that trunk and not that established for the entire connection. Finally, from an equipment viewpoint it is not necessary to provide two types of incoming registers for the handling of either transit or terminal traffic.

6.2 *One-Way Versus Two-Way Operation of Trunks*

As discussed in Section 4.5, Bell System long-haul intertoll trunks are generally operated on a two-way basis with exchange trunks being operated one way. In the United Kingdom and Europe one-way operation of trunks is the usual case. Two-way systems require symmetrical signaling terminals. The additional costs for symmetrical two-way operation as compared with unsymmetrical one-way operation are small for continuous-type signaling plans, but can be relatively expensive for spurt-

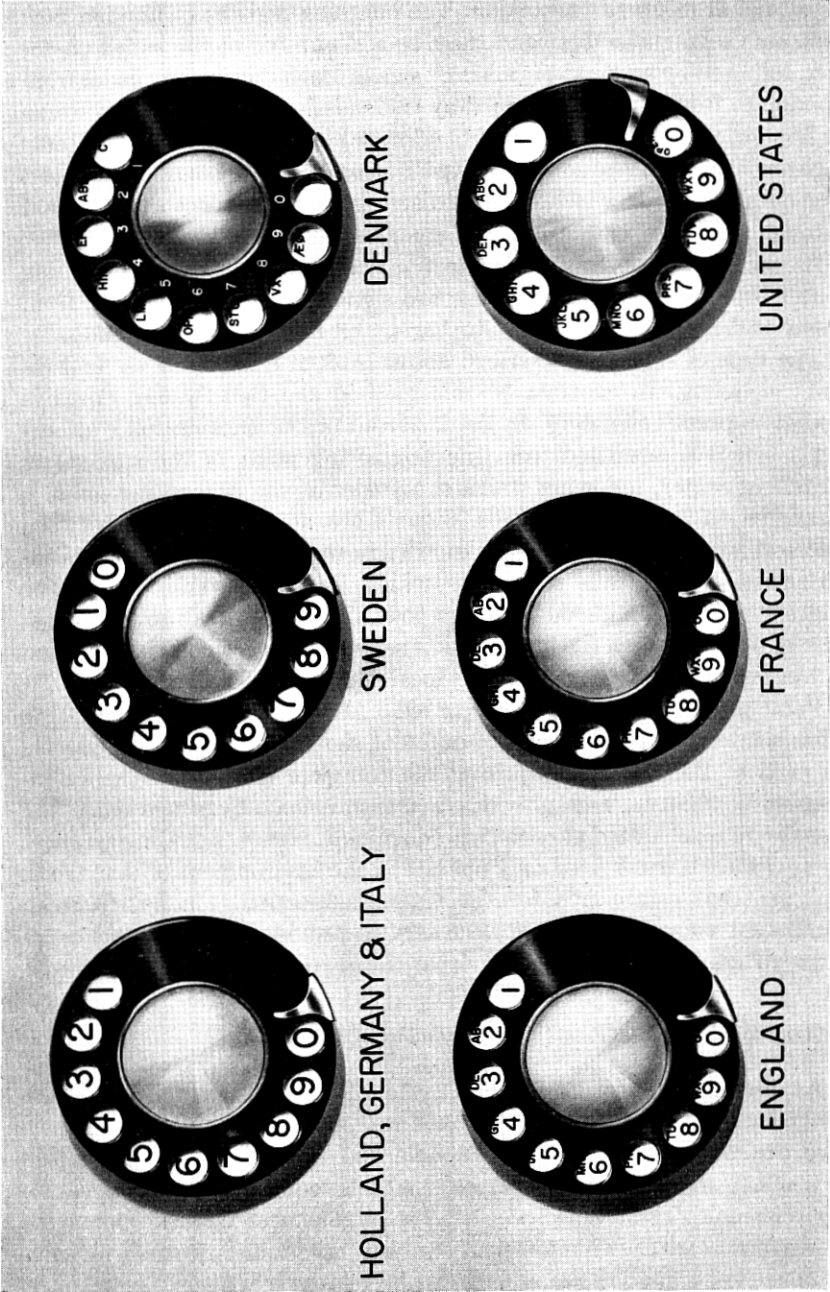

Fig. 25 — Comparison of dials.

type signaling arrangements, since additional logic and memory functions are required.

Two-way operation is essential for international trunks between North America and the United Kingdom and Europe because of the high costs of the transmission facilities and the desire to secure maximum trunk efficiency. Time zone differences increase the importance of being able to initiate calls in either direction at will.

6.3 *Differences in Dials*

Variations in the lettering and numbering of dials creates additional problems in international signaling. Fig. 25 indicates several of the arrangements used in the United Kingdom and Europe and also the United States dial. Dial differences are not serious with operator dialing, since bulletin information can be issued to operators handling calls to international points reflecting the necessary conversions. However, with customer dialing the problem is serious, since directory listings would need to be quite involved to cover the variations. A possible solution would be to adopt dials with all-numeral numbering, with the same numbers in respective holes for all countries.

Fig. 25 also points out differences in dials now using numerals only. For example the Swedish dial has the numeral 0 in the position where the numeral 1 is usually found on other dials. On the Swedish dials the digits run from 0 to 9 and on dials of other countries the digits run from 1 to 0. In this latter case the dial difference can be cared for by mechanical translation if it proves to be necessary.

6.4 *Numbering Plans*

Although the numbering plans of the various countries differ, it is not expected that this will influence the design of signaling systems. However, they will affect the associated switching systems, since the number of digits that customers must dial will affect the digit capacity of registers or senders handling the call.

6.5 *Charging for International Calls*

Allocation of charges on international calls is not primarily a signaling problem, but may at sometime require additional information signals.

6.6 *Signaling Techniques*

In recent years the desire of European countries and the United Kingdom to interconnect with each other has highlighted the necessity for

coordinating signaling systems in some fashion or agreeing to use one common system. The CCITT,* an international body of telephone administration representatives, has recommended two signaling proposals referred to as the single-frequency (1VF) and two-frequency (2VF) plans. Both systems use "spurt" signals as contrasted with "continuous" signals used in the Bell System.

In both of the "spurt" signaling systems there are signals present on the line facilities only during the intervals when it is required to transmit trunk control, status or address information. In the idle or busy conditions no tones are present whereas in continuous signaling systems, such as the Bell System SF signaling system, a low-level tone is present continuously during the idle condition. Usually no tone is present in the busy condition.

With spurt systems, signals such as connect, disconnect, on-hook, off-hook, etc. are transmitted by spurt signals comprising different combinations of frequencies and time intervals. Acknowledgment signals used to assure the two terminals of the successful transmission of the different bits of supervisory and pulsing information are also transmitted as spurts.

In addition to information and signal encoding differences in trunk control and status signals, European systems differ with respect to methods of transmitting address information. The CCITT standards were therefore proposed based on arhythmic and binary-coded signals. The arhythmic code, associated with the 1VF system, is quite similar to that used in telegraph systems. It comprises a start element, four signal elements and a stop element. The four signal elements provide 16 different combinations. (Telegraph codes usually employ five signal elements between the start and stop elements.) The binary code, associated with the 2VF system, comprises four elements separated each from the next by a silent interval, each element consisting of the transmission of one or the other of the two signaling frequencies. Here again, 16 different signal combinations are available. Fig. 26 shows both the arhythmic and binary codes.

It is obvious that the above intersystem trunk control, status and addressing methods are markedly different compared to those used in the Bell System. In view of this, the interconnecting of switching systems on opposite sides of the Atlantic is a problem. Possible solutions offer the choice of either adopting the standard of one side or the other with suitable conversion arrangements on one side to accommodate the adopted standard to its foster parent or, alternatively, formulating a

* Comité Consultatif International Télégraphique et Téléphonique.

compromise arrangement having desirable features of both Bell and European standards, with conversion arrangements at each end. As noted below, the latter alternative has been selected, with the decision having been influenced by the transmission requirements to be discussed.

6.7 *Transmission*

To provide for economically expanding the number of available trunks between the United States and the United Kingdom and Europe, two plans are being implemented. First, the bandwidths of the available channels are being slightly reduced by spacing the channels at 3-ke intervals in place of the original 4-ke spacing, thus increasing the total number of channels to 48. Second, a new transmission facility, the Time Assignment Speech Interpolation (TASI) system is being employed. As many as 36 of the 3-ke channels may be associated with the TASI system.

A TASI system assigns a speech channel to a talker only when a channel is required, and when a channel is not required it is prepared to switch that channel to another talker requiring a channel. This makes it possible to use 36 channels to serve 72 talkers, since it has been found that a speech channel is in use less than 50 per cent of the time that a call is in progress. Thus, with reduced channel frequency spacing and use of TASI, a total of 84 trunks is made available from the original 36 channels. Actually, the number of trunks available will be somewhat less than the maximum due to the need for channels to provide services that cannot be handled on TASI-derived circuits.

The basic philosophy of TASI precludes the use of any signaling system which uses continuous tones, since such tones would prevent proper interpolation of channels. It is therefore necessary to devise a signaling system compatible not only with the systems used in the terminal countries served by the cables, but also with TASI-derived trunk operation. This problem has been the subject of intensive study, and discussions have been held jointly between Bell System and the overseas telephone administrations concerned. A plan of operation has been tentatively agreed upon as described below.

6.8 *Solution*

Basically the plan proposes that all international trunks be operated on a two-way basis and that the frequencies comprising the trunk control and status signals be 2400 and 2600 cycles, either separately or combined, to provide the necessary signal distinctions. For the trans-

mission of the address information and to reach special information operators it has been agreed to use a slightly modified form of the Bell System's multifrequency key pulsing (MFKP) system in both directions.

Figs. 26 and 27 compare the trunk control, status and address signals proposed for TASI-derived trunks between North American and European terminals with those normally used in the toll plant of the Bell System and those recommended by the CCITT for use on international trunks in the United Kingdom and Europe. It should be noted that certain CCITT signals are not used, but reliability has not been sacrificed since the principles of continuous-type signaling have been followed wherever possible (such as connect and disconnect signals) without seriously affecting the efficiency of TASI. The time intervals chosen for the various signals reflect the requirement that the availability of a TASI channel must be practically assured in every case. For the connect, start-dial, forward-disconnect and disconnect-acknowledgment signals, the nature of the signal and terminal recognition arrangements provide for signal lengths as required to assure the TASI channel. The signal on the TASI channel itself is the minimum time possible, consistent with reliable operation. The other signals are timed pulses, with part of each signal assigned to the securing of the TASI channel, if necessary, and the remainder of the signal for the use of the terminal equipment.

The North American terminals are to be equipped with signaling converters connected between the trunk circuit and the TASI channelizing equipment. The Bell System terminals will include two standard SF signaling units together with certain logic and memory relay circuitry. This equipment will convert the usual "continuous" types of signals between trunk and signaling circuits to signals compatible with the concepts of TASI operation and the signaling equipment at the European terminals.

In addition to the changes in signaling philosophy, switching equipment for international calls will include the following important features which also affect the signaling system:

1. Seizure of the TASI channel will be delayed until the outgoing register contains all the necessary address information. This is desirable in order to reduce the activity on the TASI channel.

2. The incoming register groups will be liberally engineered to assure availability of a register in a minimum time. This is again desirable to reduce the duration of the seizure or connect signal and hence reduce TASI activity.

3. When the TASI channel is available and the start-dial signal has been received from the distant terminal the address information will be

SIGNALS	STANDARD BELL SYSTEM SF SIGNALING FOR INTERTOLL TRUNKS (2-WAY OPERATION) FREQUENCY = 2600 CPS		CCITT 1VF SYSTEM FOR SIGNALING OVER INTERNATIONAL TRUNKS (1-WAY OPERATION) FREQUENCY = 2280 CPS		CCITT 2VF SYSTEM FOR SIGNALING OVER INTERNATIONAL TRUNKS (1-WAY OPERATION) FREQS. = 2400 CPS, 2040 CPS		SIGNALING FOR TRANSOCEANIC TASI DERIVED TRUNKS (2-WAY OPERATION) FREQUENCIES { 2600 CPS 2400 CPS }	
	DIRECTION OF TRANSMISSION ORIG - TERM	TERM - ORIG	DIRECTION OF TRANSMISSION ORIG - TERM	TERM - ORIG	DIRECTION OF TRANSMISSION ORIG - TERM	TERM - ORIG	DIRECTION OF TRANSMISSION ORIG - TERM	TERM - ORIG
IDLE CONDITION	↑	NO TONE	NO TONE	NO TONE	NO TONE	NO TONE	NO TONE	NO TONE
SEIZURE	↑	150 600 (TERMINAL) 600 (TRANSIT)	NO TONE	NO TONE	150 (TERMINAL) 250 (TRANSIT)	NO TONE	NO TONE	NO TONE
DELAY DIAL	NO TONE	NO TONE	—	—	—	—	—	—
PROCEED TO SEND (START DIAL)	↑	NO TONE	NO TONE	150 (TERMINAL AND TRANSIT)	NO TONE	150 (TERMINAL) 150 (TRANSIT)	↑	↑
ADDRESS SIGNALS	MFKP	↑	ARITHMIC CODE	NO TONE	BINARY CODE	NO TONE	MFKP	NO TONE
DIGIT RECEIVED	—	—	—	—	—	—	—	—
NUMBER RECEIVED	—	—	NO TONE	150	NO TONE	150 150 150 150	—	—
CUSTOMER ANSWER	NO TONE	NO TONE	NO TONE	150 150 100	NO TONE	150 150 150	NO TONE	850
CALLED CUSTOMER HANG-UP (ON HOOK, CLEAR BACK)	NO TONE	NO TONE	NO TONE	600	NO TONE	150 250	NO TONE	850
DISCONNECT-FORWARD (CLEAR FORWARD)	↑	600 100 600	NO TONE	NO TONE	150 350	NO TONE	↑	NO TONE
DISCONNECT - ACKNOWLEDGE (RELEASE GUARD)	—	NO TONE	NO TONE	600 100 600	NO TONE	350 150	↑	↑
RING FORWARD (FORWARD TRANSFER)	70-130	150 150 100	NO TONE	NO TONE	350 150	NO TONE	850	NO TONE
BUSY-REORDER-NO CIRCUIT (BUSY FLASH)	NO TONE	NO TONE	NO TONE	600	NO TONE	150 250 250	NO TONE	AUDIBLE TONE (30, 60, 120 IPM)*

▷ CONTINUOUS TONE
DURATION OF PULSES INDICATED IN MILLISECONDS

* FOR CALLS TO UNITED KINGDOM & EUROPE, A BUSY FLASH SIGNAL MAY BE USED, EITHER ALONE OR ACCOMPANIED BY AUDIBLE TONE

Fig. 27 — Comparison of trunk control and status symbols.

transmitted without interruption and with signal intervals, both on and off time, of such duration as to guarantee the continuity of the channel.

4. Transmit and terminal-seize distinctions will be made by encoding the KP signal preceding the address signals.

5. A language signal consisting of an MF digit will, on terminal calls, be transmitted between the KP signal and the address to make it possible, when necessary, to call in an assistance operator. On transit calls the language digit will follow the two digits designating the international country code.

6. The terminating trunk circuit will be arranged to permit the calling-in of an assistance operator on a dial established connection when a ring-forward signal is received.

VII. FUTURE TRENDS

From the foregoing survey of the events and effects leading to the present state of the signaling art, it will be apparent that the signaling background has been deeply interrelated with the evolution of the telephone plant as a whole. Looking toward the future, one might logically conclude that signaling systems will continue to be closely allied with progress in the switching and transmission fields. Advances in the electronic component field and in related arts will undoubtedly contribute substantially to the technology of signaling, but future system trends will be tempered by the economic strains which inevitably occur in fitting tomorrow's plans to today's plant.

The foreseeable future, as indicated by trends already established, will bring more and more fully customer-controlled traffic — within the exchange plant as well as within the DDD network — and less operator-directed traffic. While this probably will not cause changes in signaling design requirements *per se*, other than to diminish the need for signals required only by operators, it will place more and more dependence on the reliability of signaling systems. Thus, one might expect a continued acceleration in the use of self-checking multifrequency signaling where a choice of engineering alternatives exists between this and other forms of signaling. By the same token, one might expect a lessening in the use of interoffice dial pulsing, either through gradual obsolescence of step-by-step central offices or through some form of senderization. There will probably be a decline in the use of PCI signaling as local manual switchboards disappear and as local office DDD sender modifications supersede, with MF signaling, the use of PCI signals to tandem offices. Further, as panel switching offices are replaced by more modern switching systems, there will be a corresponding reduction in the use of re-

vertive pulsing and a lessening of the tendency to employ this form of signaling between crossbar offices. Continued growth in the use of exchange carrier and small-gauge repeatered cable facilities will also promote an increasing use of AC signaling in the exchange plant. Thus, in the foreseeable future one might expect the emergence of multifrequency signaling as the basic standard for signaling between offices, with other methods of signaling falling by the wayside.

Beyond the more obvious trends lies the possibility that the future may bring to fruition some of the signaling systems and services which are now only in the experimental or introductory state. Of interest among these are pushbutton signaling systems wherein the customer's conventional telephone dial is displaced by ten (or perhaps more) pushbuttons, each of which is capable of generating a unique signal, similar to the multifrequency signaling system. Such systems require that register (or sender) operation of some form be present in the central office switching systems to receive and act upon the signals generated by the customer's pushbuttons. Since, as mentioned earlier, a sender-type central office serves as a buffer between the customer and interoffice signaling systems, customer pushbutton systems probably will not influence directly present-day interoffice signaling systems. However, it is possible that an indirect effect may result, since by injecting pushbutton register-senders into non-common-control offices, the potential use of such senders to transmit other than dial pulses to connected switching systems may become attractive.

The use of AC types of pushbutton operation will undoubtedly stimulate intercustomer signaling, wherein pushbutton signals originated at one station will be used to control devices or switching operations at a distant station. Careful integration of these over-all signaling systems with the interoffice signaling systems will be required, however, to ensure satisfactory transmission and to avoid mutual interference.

Wider use of other systems as yet in the experimental stage may in the future result in substantial changes in interoffice signaling. For example, high-speed data links carrying signaling information for large groups of trunks might become attractive; there also exist new signaling possibilities such as digital switching and transmission systems employing pulse code modulation techniques. In the latter system one or two bits are added to each of the digital "words" used to transmit a quantized speech sample, and these bits convey the signaling information. Such signaling systems may in the future be competitive with present-day systems; they have the capability of transmitting signaling information at high speed. In this connection, electronic switching systems,

which can efficiently handle high-speed interoffice signaling, may bring about wide use of high-speed frequency division systems (characterized by multifrequency systems) or time division, as characterized by PCM or similar systems.

Looking toward the more distant future, one discerns the possibility that switching systems will be able to capitalize on higher and higher signaling speeds between switching offices, that transmission systems will be available to handle these speeds economically and that message services (such as, for example, data communications over the telephone plant) having high calling rates and short holding times will place a high premium on rapid switching and signaling. It is a matter of conjecture whether increased signaling speed will be obtained by frequency-division systems, by serial transmission or by one or the other in combination with multiplexing techniques. One also anticipates the possibility that the direct dialing network will be broadened to include new areas, new countries and perhaps new dimensions — and that this and other new services will probably require new techniques and the transmission of additional signals conveying new information.

Finally, taking the long look toward sheer fantasy (the inevitable goal of most predictors of the future) one is struck by the thought that it is necessary to reach way out to insure that a prediction of future communication possibilities will indeed be fantastic. Stopping just short of this, one wonders if Alexander Graham Bell's historic telephone summons to his assistant, Mr. Watson, might one day be repeated into some exotic communication network, and that "Watson" will be summoned to the telephone more quickly than his predecessor was able to reach Mr. Bell's side. If switching engineers can devise switching facilities to do this, and if transmission engineers will do their part, signaling engineers will do their best to see that Mr. Watson is summoned, wherever he is.

BIBLIOGRAPHY

1. Seudder, F. J. and Reynolds, J. H., Crossbar Dial Telephone Switching System, *B.S.T.J.*, **18**, 1939, p. 76.
2. Sheppard, H. A., A Signaling System for Intertoll Dialing, *Bell Lab. Rec.*, **18**, 1940, p. 337.
3. Abraham, L. G., Busch, A. J. and Shipley, F. F., Crossbar Toll Switching System, *A.I.E.E. Trans.*, **63**, 1944, p. 302.
4. Dahlbom, C. A., Horton, A. W., Jr. and Moody, D. L., Applications of Multifrequency Pulsing in Switching, *A.I.E.E. Trans.*, **68**, 1949, p. 392.
5. Korn, F. A. and Ferguson, J. G., The No. 5 Crossbar Dial Telephone Switching System, *A.I.E.E. Trans.*, **69**, Pt. 1, 1950, p. 244.
6. Caruthers, R. S., Kahl, W. E. and Pedersen, L., The N-1 Carrier Telephone System, *B.S.T.J.*, **30**, 1951, pp. 1; 418.
7. Clark, A. B., The Development of Telephony in the United States, *A.I.E.E. Trans.*, **71**, Pt. 1, 1952, p. 348.

8. Myers, O., Common Control Telephone Switching Systems, B.S.T.J., **31**, 1952, p. 1086.
9. Yokelson, B. J., New Multifrequency Receiver, Bell Lab. Rec., **32**, 1954, p. 221.
10. Comité Consultatif International Télégraphique et Téléphonique, XVIIth Plenary Assembly, Geneva, October 4-12, 1954, Vol. V, Signaling and Switching.
11. Weaver, A. and Newell, N. A., In-Band Single-Frequency Signaling, B.S.T.J., **33**, 1954, p. 1309.
12. Horton, A. W., Jr. and Vaughan, H. E., Transmission of Digital Information over Telephone Circuits, B.S.T.J., **34**, 1955, p. 511.
13. Adam, A. O., Crossbar Tandem as a Long Distance Switching System, B.S.T.J. **35**, 1956, p. 91.
14. Joel, A. E., Jr., An Experimental Switching System Using New Electronic Techniques, B.S.T.J., **37**, 1958, p. 1091.
15. Pennoyer, D. H., Automatic Number Identification and Its Application to No. 1 Crossbar, Panel and Step-by-Step Offices, B.S.T.J., **37**, 1958, p. 1295.
16. Bullington, K. and Fraser, J. M., Engineering Aspects of TASI, B.S.T.J., **38**, 1959, p. 353.
17. Green, E. I., Evolving Technology of Communication, Elect. Engg., **78**, 1959, p. 470.
18. Vaughan, H. E., Research Model for Time-Separation Integrated Communication, B.S.T.J., **38**, July 1959, p. 909.
19. Dahlbom, C. A., Transistorized Signaling System: Engineering Aspects, Bell Lab. Rec., **37**, 1959, p. 254.
20. Schenker, L., Pushbutton Calling with a Two-Group Voice-Frequency Code, B.S.T.J., **39**, 1960, p. 235.
21. Newell, N. A., DX Signaling, Bell Lab. Rec., **38**, 1960, p. 216.