

Conversion of Maxwell's Equations into Generalized Telegraphist's Equations*

By S. A. SCHELKUNOFF

(Manuscript received May 3, 1955)

In this paper it is explained how Maxwell's field equations together with the appropriate boundary conditions may be converted into equations analogous to those for coupled transmission lines. This makes it possible to use the well-known techniques of dealing with transmission lines to solve certain field problems in those cases in which either the method of separating the variables fails or the boundary conditions are too complicated for the conventional method. For example, this method may be applied to studying waveguide to horn junctions, bending of waveguides, propagation of waves over an imperfect earth in the vicinity of the source, etc. Other applications are suggested in the course of the paper.

On the theoretical side, this conversion of field equations into transmission line equations brings together two heretofore independent theories of wave propagation on wires, namely, Lord Kelvin's theory based on circuit concepts and Kirchhoff's laws and Mie's theory based on field concepts and Maxwell's equations.

The "Generalized Telegraphist's Equations" derived in this paper differ from Kelvin's classical Telegraphist's Equations in two respects. Firstly, for a pair of conductors Kelvin obtained one pair of differential equations implying the existence of only one mode of propagation. For the same pair of conductors we obtain an infinite set of equations implying an infinite number of modes, from which Kelvin's equations are obtained by neglecting the

* The substance of this paper was presented at a joint meeting of the International Scientific Radio Union (U. S. A. National Committee), the Institute of Radio Engineers (Professional Groups on Antennas and Propagation, and Microwave Theory and Techniques), and American Geophysical Union (Section of Terrestrial Magnetism and Electricity) on May 4, 1954, Washington, D. C., under the title "Solution of Field Problems with the Aid of Distributed Circuit Parameter Concepts." Subsequently, it was presented at a Conference on Fields held on January 31, 1955 during the Winter General Meeting of the American Institute of Electrical Engineers in New York. This paper was also presented at the University of Bristol, England, on May 25, 1955, and at the Technische Hochschule in Zurich, Switzerland, on June 13, 1955.

coupling between the principal mode and the higher order modes. Secondly, our equations for some transmission structures contain additional "circuit parameters" which do not appear in the classical equations. These parameters are of the same nature as those in the corresponding equations for waveguides of uniform cross-section with perfectly conducting walls and filled with heterogeneous dielectric medium. In the present case they arise from the boundaries of conductors rather from lack of homogeneity.

The mathematics of converting Maxwell's Equations into Generalized Telegraphist's Equations is straightforward, although in the most general cases rather lengthy. The essential point is that a function, which for practical purposes is sufficiently arbitrary, may be represented in numerous ways by a series of orthogonal functions; and that when some such series are non-differentiable, the required relations between the coefficients of series representing the various field components may be obtained from Maxwell's equations by integration rather than by conventional substitution followed by differentiation.

CONTENTS

1. Introduction	996
2. Heuristic discussion of conversion of field equations into generalized telegraphist's equations	1001
3. The form of generalized telegraphist's equations	1003
4. Uniform strip transmission lines — the principal mode	1006
5. Uniform strip transmission lines — higher order modes	1009
6. Strip transmission line with variable cross-section — the principal mode	1011
7. Strip transmission line with variable cross-section — higher order modes	1012
8. Bent strip transmission lines — the principal mode	1013
9. Bent strip transmission lines — higher order modes	1016
10. Expanding strip transmission lines in curvilinear coordinates — a case in which Maxwell's equations are not separable	1017
11. Transverse electric modes between parallel planes	1022
12. Waves on infinite conductors	1024
13. Waves on semi-infinite conductors	1029
14. Waves over a plane impedance sheet	1029
15. Derivation of approximate telegraphist's equations for the TE_{11} mode in a circular waveguide-to-horn junction	1030
16. Effect of coupling on degenerate or nearly degenerate modes	1034
17. Coaxial conductors — circularly symmetric modes	1034
18. Vane attenuators	1037
19. Arbitrariness of modal transverse field patterns	1039
20. Concluding remarks	1040

1. INTRODUCTION

For certain structures Maxwell's equations together with boundary conditions can be converted into exact or nearly exact equations similar to telegraphist's equations for coupled transmission lines. These structures include conventional dissipative wire transmission lines, dissipative

coaxial conductors, dissipative waveguides of either constant or variable cross-section, bent waveguides, plane and curved earth, etc. The coefficients in these equations play the role of "distributed circuit parameters;" but they are obtained from Maxwell's equations and boundary conditions rather than from consideration of static electric and magnetic fields. The distributed circuit parameters of some structures may be interpreted as distributed self and mutual series impedances and shunt admittances. But, in general, there are other distributed parameters which may be called "voltage and current transfer coefficients." The general equations are thus of the same form as the equations previously obtained by the author for waveguides of constant cross-section with perfectly conducting walls and filled with nonhomogeneous dielectric and magnetic media.

The possibility of converting Maxwell's equations into generalized telegraphist's is important from theoretical and practical points of view. This possibility removes a nagging feeling that the classical telegraphist's equations, useful as they are in practice, are fundamentally inconsistent with Maxwell's field theory. We shall find that they *are* consistent although approximate. We shall find that for conventional transmission lines, such as coaxial pairs, the generalized telegraphist's equations reduce to classical telegraphist's equations when the distributed coupling of the principal mode to the higher order modes is neglected. We also find that the classical equations can be used at much higher frequencies than one would expect from their conventional derivation based on the assumption of quasi-stationary fields. On the practical side, the generalized telegraphist's equations represent a method for solving boundary value problems using the well-known transmission line concepts and techniques. In a gentle waveguide to horn junction, for instance, we can obtain in the first approximation the transmission equations for the dominant mode and then calculate the higher order modes, generated by the expanding boundaries, as "crosstalk" between the dominant and higher order modes in the same way we calculate the crosstalk between adjacent conventional transmission lines in a cable. Thus we can look at three dimensional wave propagation from another angle, from the point of view of one dimensional propagation. We can also treat problems in curvilinear coordinates when the variables are not separable.

The conversion of Maxwell's equations into generalized telegraphist's equations brings together two independent theories of wave propagation, based on quite different concepts, which have merely "coexisted" for more than three quarters of a century. Lord Kelvin obtained his telegraphist's equations for cables¹ (transmission lines) ten years before

Maxwell formulated his field equations. In modern notation the telegraphist's or transmission line equations for two conductors, Fig. 1, are

$$\frac{\partial V^i}{\partial z} = -RI^i - L \frac{\partial I^i}{\partial t}, \quad \frac{\partial I^i}{\partial z} = -GV^i - C \frac{\partial V^i}{\partial t} \quad (1)$$

where R, L, G, C are respectively the resistance, inductance, conductance and capacitance per unit length along the line. The dependent variables I^i, V^i are the instantaneous values of the current in one conductor and the transverse voltage from it to the other conductor. The distributed circuit parameters R, L, G, C are computed from static considerations. In computing R it is assumed that direct current is flowing in one conductor and returning via the other. The same assumption is made in computing the magnetic flux linkage per unit length and hence in computing L . In computing G a constant voltage is assumed to exist be-

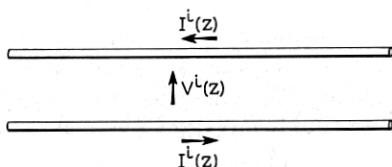

Fig. 1 — Parallel wires.

tween two conductors. The ratio of the resulting transverse direct current per unit length to this voltage is G . Finally, in computing the capacitance per unit length, C , it is assumed that $G = 0$ and that there is a constant voltage between the conductors. The ratio of the charge to this voltage is C .

On solving these equations for a sinusoidally varying applied voltage we find that the current and voltage are propagated with a finite velocity and that their amplitudes diminish exponentially with the distance from the generator. But in deriving these equations it has been assumed that these amplitudes are independent of the distance from the generator. Hence one would expect the equations to deteriorate steadily as the frequency increases. One derives the same impression from the point of view of Maxwell's theory. And yet experiments have shown that in many practical situations the errors are too small for detection even at very high frequencies. Since the "engineering theory," based on Kelvin's equations of Kirchhoff's type, is much simpler in practical applications than Maxwell's theory, it had continued to play the dominant role in electrical communication until the coming of radio and waveguides. To appreciate the difference in the "orders of complexity" of these two

theories one should glance at the forty-nine pages of Mie's paper on wave propagation along parallel wires² and compare them with the engineering solution of the same problem. In Mie's paper the reader is confronted with an elaborate and difficult mathematical analysis while the engineering solution is just a simple problem of elementary calculus. Mie's analysis is good only for an infinitely long pair of parallel metal cylinders imbedded in a homogeneous medium. On the other hand, the engineering solution applies to wires of variable cross-section, to twisted pairs of wires, to wires which are not straight and parallel, to wires insulated with layers of different media, to wires supported by insulators on poles — that is, to a wide range of cases in which an analysis based on Maxwell's field equations seems hopeless. On the other hand, there are problems of radiation whose solutions can readily be deduced from field equations and which apparently are not amenable to treatment with the aid of classical concepts of distributed circuit parameters.

Thus, the two theories have coexisted side by side but not on "speaking-terms with each other." This situation has been one of continued challenge to students of electromagnetic theory. John R. Carson,³ for instance, derived the classical telegraphist's equations from the Lorentz solution of Maxwell's equations in terms of retarded potentials and stated clearly the approximations he had to make. He then concluded that the accuracy of telegraphist's equations decreases with increasing frequency. Recently the author had an occasion to discuss the subject of this paper with A. Clavier. He informed me that many years ago when he taught electromagnetic theory at Ecolè Supérieure d'Electricité, he became interested in the relation between Kirchhoff's type of theory of long lines and Maxwell's field theory. At that time he found that, in the case of simple geometry and no loss, the Lorentz solution of Maxwell's equations in terms of retarded potentials yielded a set of equations, identical in form with (1) but with a different meaning ascribed to V^i . The same result may be obtained directly from Maxwell's equations^{4, 5} if in the case $R = 0$ we restrict ourselves to TEM waves, in which case V^i has the meaning identical with that ascribed to it by Lord Kelvin.

For continuously coupled transmission lines, for several parallel wires for instance, telegraphist's equations are

$$\frac{\partial V_m^i}{\partial z} = -\sum_n \left(R_{mn} I_n^i + L_{mn} \frac{\partial I_n^i}{\partial t} \right),$$

$$\frac{\partial I_m^i}{\partial z} = -\sum_n \left(G V_{mn}^i + C_{mn} \frac{\partial V_n^i}{\partial t} \right) \quad (2)$$

where I_m^i is the instantaneous current in the m -th line and V_m^i the in-

stantaneous transverse voltage associated with the m -th line. The coefficients corresponding to $n = m$ are the distributed circuit parameters for the m -th line, and those corresponding to unequal values of m and n are the distributed coupling parameters for the m -th and n -th lines. For steady state these equations reduce to a system of ordinary differential equations. This reduction is accomplished by regarding the instantaneous voltages and currents, V_m^i and I_m^i , as the real parts of complex voltages and currents, $V_m \exp(j\omega t)$ and $I_m \exp(j\omega t)$. Thus (2) is transformed into

$$\frac{dV_m}{dz} = -\sum_n Z_{mn} I_n, \quad \frac{dI_m}{dz} = -\sum_n Y_{mn} V_n \quad (3)$$

where the distributed complex impedances per unit length, Z_{mn} , and complex admittances per unit length, Y_{mn} , are

$$Z_{mn} = R_{mn} + j\omega L_{mn}, \quad Y_{mn} = G_{mn} + j\omega C_{mn} \quad (4)$$

The usefulness of (1) and (2) is severely restricted because even for relatively slowly varying currents the resistance R of a conductor is not independent of time. The voltage drop across a section of a conductor depends not only on the current but on the second and higher time derivatives of the current. It is for this reason that (1) is properly named "telegraphist's" rather than "telephonist's" equations. However, (3) may be used even at quite high frequencies provided we use ac resistances R_{mn} , which include the skin effect, in place of dc resistances. A similar allowance should be made for the internal inductances of the conductors.

It has been shown⁶ that for each mode of propagation in a perfectly conducting waveguide of uniform cross-section it is possible to obtain equations analogous to telegraphist's equations. Thus for TM waves the steady state equations of propagation are

$$\frac{dV}{dz} = -\left(j\omega\mu + \frac{\chi^2}{g + j\omega\epsilon}\right) I, \quad \frac{dI}{dz} = -(g + j\omega\epsilon) V \quad (5)$$

and for TE waves

$$\frac{dV}{dz} = -j\omega\mu I, \quad \frac{dI}{dz} = -\left(g + j\omega\epsilon + \frac{\chi^2}{j\omega\mu}\right) V \quad (6)$$

where the constant χ depends on the shape and size of each conductor and on the field distribution in a typical transverse plane. The "voltage" V and the "current" I are related to the magnitudes of the transverse components of electric and magnetic intensities.

In this paper we shall be concerned primarily with the steady-state

equations. This entails no loss in generality because the Laplace transform method would enable us to find the more general solutions from the steady state solutions. It is possible, however, to convert such equations as above into forms applicable to non-periodic time variations in the dependent variables. Thus (6) would become

$$\frac{\partial V^i}{\partial z} = -\mu \frac{\partial I^i}{\partial t}, \quad \frac{\partial I^i}{\partial z} = -gV^i + \epsilon \frac{\partial V^i}{\partial t} + \mu^{-1} \chi^2 \int_{-\infty}^t V^i(\tau) d\tau \quad (7)$$

The first equation of the set (5) can be transformed either into

$$g \frac{\partial V^i}{\partial z} + \epsilon \frac{\partial^2 V^i}{\partial t \partial z} = -g\mu \frac{\partial I^i}{\partial t} + \mu\epsilon \frac{\partial^2 I^i}{\partial t^2} - \chi^2 I^i \quad (8)$$

or into

$$\frac{\partial V^i}{\partial z} = -\mu \frac{\partial I^i}{\partial t} - \chi^2 \epsilon^{-1} \int_{-\infty}^t I^i(\tau) e^{-(g/\epsilon)(t-\tau)} d\tau \quad (9)$$

However, the steady state equations combined with Laplace transforms are, as a rule, more convenient for dealing with general time varying phenomena than the nonsteady state equations.

2. HEURISTIC DISCUSSION OF THE PROBLEM OF CONVERTING FIELD EQUATIONS INTO GENERALIZED TELEGRAPHIST'S EQUATIONS

Consider two coaxial conductors. If they are perfectly conducting, the field between them may be expressed in terms of TEM, TE, and TM modes. Each of these modes can exist independently of the others. Suppose now that we have excited a pure TEM mode. Let us then introduce a small resistive spot on one of the cylinders. Some current will flow across the spot and will give rise to a non-vanishing electric intensity tangential to the spot. This intensity will act as an impressed longitudinal intensity and will thus generate a large number of modes traveling in opposite directions from the spot. Let us introduce another spot, and then another and another until both cylinders are covered by resistive films. At each step various modes will be generated and regenerated. The argument suggests that we should be able to express the field *between* the imperfectly conducting cylinders in terms of modes appropriate to perfectly conducting cylinders. However, none of the latter modes can now exist independently of the others. The surface impedance of the cylinders provides continuous coupling between various modes.

In the case of imperfectly conducting cylinders the longitudinal electric intensity does not vanish at the surface of either conductor and

yet the above physical argument leads us to believe that we can express it in terms of functions which vanish there. Are we facing a contradiction? The answer is, no. The functions representing the longitudinal intensity over a given cross-section when the cylinders are perfectly conducting form a complete orthogonal set. This set is sufficient for representing arbitrary continuous functions, which do not vanish on the boundary of the cross-section, at all points *except on the boundary itself*. The situation is analogous to that existing in Fourier analysis. A function which is bounded and continuous in the closed interval $(0, \ell)$ may be represented by a sine series in an open interval even when the function does not vanish at the ends of the interval. However, the series will be non-uniformly convergent and non-differentiable. For this reason such series cannot be substituted in Maxwell's equations when differentiation is required. However, there is a way of overcoming this difficulty which can best be illustrated by an example. As far as the representation of the longitudinal electric intensity is concerned, we shall have one series for points in the interior of the waveguide and another on its boundary. The latter is obtained from the boundary condition, that is from the product of the surface impedance and the tangential magnetic intensity.

A waveguide with continuously varying cross-section may be regarded as the limit of a waveguide made up of a large number of very short waveguides with constant but different cross-sections. Consider only one sudden change in the cross-section. The effect of this discontinuity on a wave in one mode is to produce waves in many other modes traveling in opposite directions from the discontinuity. Hence, the discontinuity couples various modes and an expanding boundary represents continuous coupling. Bending also represents continuous coupling.

In some structures the modes of propagation will be spherical or systems of spherical and plane modes. Take for instance a perfectly conducting cone. There will be two systems of spherical modes of propagation, internal and external, completely independent of each other. If the perfectly conducting cone is replaced by a sheet of finite thickness and conductivity, there will exist a linear relation between electric and magnetic intensities tangential to the internal and external surfaces of the sheet; thus

$$\begin{aligned} E_{\tan}^e &= Z_{ee}H_{\tan}^e + Z_{ei}H_{\tan}^i \\ E_{\tan}^i &= Z_{ie}H_{\tan}^e + Z_{ii}H_{\tan}^i \end{aligned} \quad (10)$$

where the Z 's are the surface and transfer impedances of the sheet. This equation expresses the coupling between external and internal waves. If

the conical conductor is deformed, further coupling arises from the deformation. The cone may be deformed into a cylinder, in which case the external waves will still be spherical while the internal waves will become plane.

We can make our calculations of fields step by step as suggested by the heuristic argument. For example, we can calculate the scattering from a typical resistive spot and integrate the scattered field over a continuous distribution of spots. Since we would be neglecting the second order scattering, our result would be approximately true only for a sufficiently small perturbation of the original field. This is the method used by S. P. Morgan⁸ to obtain mode conversion losses in transmission of circular electric waves through slightly non-cylindrical guides. If the first order perturbation is not good enough, one presumably could calculate higher order perturbations. However, this direct method, although very useful in some situations, has its limitations. For instance, no matter how small is the dissipation, the amplitude of the wave will be attenuated with the increasing distance from the source while the amplitude of the wave "unperturbed" by the resistance would have remained constant.

In the next section we shall state the generalized telegraphist's equations. The remainder of the paper will be devoted to the mathematical technique of obtaining them from Maxwell's equations. This technique is simple in principle but in general cases requires rather lengthy mathematical manipulation which might obscure the main ideas. For this reason the technique will be illustrated by a series of simple examples.

3. THE FORM OF GENERALIZED TELEGRAPHIST'S EQUATIONS

In a previous paper⁷ we obtained from Maxwell's equations the following equations for waveguides of uniform cross-section, bounded by perfectly conducting walls, and filled with nonhomogeneous dielectric and magnetic media

$$\begin{aligned} \frac{dV_m}{dz} &= -\sum_n Z_{mn} I_n - \sum_n {}^V T_{mn} V_n \\ \frac{dI_m}{dz} &= -\sum_n Y_{mn} V_n - \sum_n {}^I T_{mn} I_n \end{aligned} \quad (11)$$

The equations which we shall obtain in this paper are of the same form. They are more general than the classical telegraphist's equations, given in (3), for conventional transmission lines since, in addition to distributed series impedances Z_{mn} and shunt admittances Y_{mn} , (11) contains "voltage transfer coefficients" ${}^V T_{mn}$ and "current transfer coefficients" ${}^I T_{mn}$.

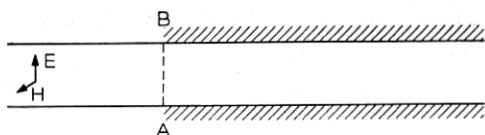

Fig. 2 — Two parallel planes, perfectly conducting to the left of the junction AB and imperfectly conducting to the right of it.

The voltages, V_m , and currents, I_m , are related to the amplitudes of electric and magnetic intensities associated with each particular mode. To each pair, V_m and I_m , there corresponds a certain field pattern in the transverse plane. The choice of these field patterns is essentially arbitrary.* Often the most convenient choice is the one for which the mutual coefficients are as small as possible so that the corresponding modes are as independent as possible. But this is not always the case. For example, take a junction between a pair of perfectly conducting parallel planes and a pair of imperfectly conducting planes, Fig. 2. Consider what happens near the junction AB when the TEM mode is traveling from the left toward the junction. In this mode E is constant in the vertical direction. Between the imperfectly conducting planes we can represent the entire field in terms of certain independent modes by solving the appropriate boundary value problem.⁹ If the distance between the planes is sufficiently large in comparison with wavelength, there is no mode in which E is either constant in the vertical direction or nearly constant. No matter how small is the surface resistance of the planes (as long as it is different from zero), by spreading the planes we can reach a condition in which the vertical electric intensity is distributed almost sinusoidally with height, the maximum occurs half way between the planes, and the minima near the planes. It is quite evident that these modes are not the best for representing the field near the junction. From physical considerations we expect that after the TEM wave enters the space between the imperfectly conducting planes, it is still the same wave for considerable distance except near the planes. If we expand the field to the right of AB in terms of modes appropriate to perfectly conducting planes, we will have a mode with constant vertical electric intensity. This mode will be feebly coupled to higher order modes. On account of this feeble coupling the field near the junction is not much different from that which would exist between perfectly conducting planes. However, under the postulated conditions there are many higher order modes which travel with almost the same velocity as the principal mode. For this reason the conversion from the principal mode to these higher order

* Just as arbitrary as the choice of "meshes" in writing Kirchhoff's equations.

modes will be cumulative and eventually the transverse field pattern will become totally unlike that near the junction. This final pattern is best obtained by solving the conventional boundary value problem; but there is a large region near the junction where the representation in terms of modes appropriate to perfectly conducting planes is much more practical.

In some instances, particularly when the mutual impedances and admittances are small and transfer coefficients vanish, it is possible to calculate the mutual coefficients from the power flow along the guide and the power absorbed by its wall. In the middle thirties this author obtained in this way the coupling between TM and TE waves in dissipative cylindrical waveguides. The result agreed with that obtained from the appropriate characteristic equation for hybrid waves (unpublished work). Much more important was the application of this idea by W. J. Alberheim¹⁰ to the propagation of circular electric waves round a bend. It is equally possible to obtain small coupling coefficients due to small irregularities in the dielectric medium from the unperturbed field which would exist if these irregularities were removed by calculating the response to the relative polarization currents.

In general, (11) is simpler to work with than the original Maxwell's equations. In particular, when the mutual coefficients (those corresponding to the unequal subscripts) are small, we can solve the equations by successive approximations as in problems of cross-talk between conventional transmission lines in a cable. That is, we first neglect the coupling between various modes and obtain the first approximate solution. Then we calculate the voltages and currents induced from each mode into every other mode in a typical element of length dz (that is, $Z_{mn}I_n^{(0)} dz$, $Y_{mn}V_n^{(0)} dz$, etc. where $I_n^{(0)}$ and $V_n^{(0)}$ represent the first approximations). These induced voltages and currents we regard as impressed voltages and currents exciting waves in the corresponding modes. The effects of these impressed voltages and currents are then obtained by integration. This process can be repeated indefinitely. But usually the second approximation is sufficient for practical purposes.

However, if two or more modes have the same propagation constant, we have a situation analogous to that existing in directional couplers. No matter how small is the coupling, all power may pass from one mode to the other. In this case, on account of the coupling the common propagation constant will be split into several nearly equal propagation constants.

In concluding this section we would like to call the reader's attention to a rather curious situation which existed before the present derivation

of generalized telegraphist's equations from Maxwell's field equations. The conventional derivation of classical telegraphist's equations (3) led one to expect that in general the mutual distributed parameters will differ from zero. The *independent* modes of propagation are obtained *after* these equations have been solved. On the other hand, in each case in which telegraphist's equations, such as (5) and (6), were obtained from Maxwell's equations, the modes were invariably independent. Obviously, this independence of modes was due to the fact that selected situations were rather trivial: Maxwell's equations were separable in the chosen coordinates and the boundary conditions were particularly simple. The independence was purely accidental, inherent in the popular method of solving Maxwell's equations, and limited to the problems which could be handled by that method.

4. UNIFORM STRIP TRANSMISSION LINES — THE PRINCIPAL MODE

The simplest mode of propagation between perfectly conducting parallel plane sheets is the TEM mode in which the electric lines of force are normal to the planes and the magnetic lines are parallel to them. Let us assume that the x and y axes are parallel respectively to electric and magnetic lines. The field of this mode will then be independent of the y coordinate, and Maxwell's equations reduce to

$$\frac{\partial E_x}{\partial z} = -j\omega\mu H_y + \frac{\partial E_z}{\partial x}, \quad \frac{\partial H_y}{\partial z} = -(g + j\omega\epsilon)E_x \quad (12)$$

$$E_z = \frac{1}{g + j\omega\epsilon} \frac{\partial H_y}{\partial x} \quad (13)$$

For the mode under consideration E_z vanishes identically and therefore H_y and E_x are independent of the x coordinate as well. Essentially the same situation will exist if we cut the planes as shown in Fig. 3 to form a strip transmission line with "guards" to keep the field from spreading into the outer space.

If the sheets are not perfectly conducting, E_z does not vanish on their surface but is proportional to the linear current densities, that is, to the tangential magnetic intensities

$$E_z(0, z) = Z_1 H_y(0, z), \quad E_z(a, z) = -Z_2 H_y(a, z) \quad (14)$$

The coefficients Z_1 and Z_2 are the surface impedances of the sheets. Hence, E_z will not vanish between the sheets. From the heuristic argument expounded in Section 2 we attribute this effect of finite conductivity to the production of higher modes of propagation. For good

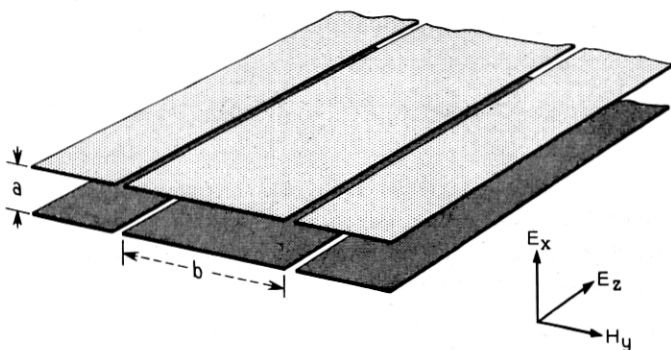

Fig. 3 — Uniform strip transmission line.

conductors Z_1 and Z_2 are extremely small so that while E_z cannot vanish, it can be very small. This "almost TEM" mode is often called the principal mode.

The transverse components of the field between and on the impedance strips will now be expressed in the following form

$$\begin{aligned} E_x &= \frac{V_0(z)}{a} + \sum N_n^{-1} V_n(z) \cos \frac{n\pi x}{a} \\ H_y &= \frac{I_0(z)}{b} + \sum N_n^{-1} I_n(z) \cos \frac{n\pi x}{a} \end{aligned} \quad (15)$$

where the summation index assumes all integral values from 1 to ∞ . The normalization factors

$$N_n^2 = \int_0^a \int_0^b \cos^2 \frac{n\pi x}{a} dx dy = \frac{1}{2} ab \quad (16)$$

are chosen to make the expression for the power flow identical with that for a multiple-conductor conventional transmission line, that is,

$$P = \frac{1}{2} \int_0^a \int_0^b E_x H_y^* dx dy = \frac{1}{2} V_0(z) I_0^*(z) + \frac{1}{2} \sum V_m(z) I_m^*(z) \quad (17)$$

When the strips are perfectly conducting the voltages and currents, $V_n(z)$ and $I_n(z)$, are independent of each other; otherwise, they are not. From the purely mathematical point of view we can regard expressions (15) as representations of the solutions between the impedance strips by cosine series. Such representations exist because E_x and H_y are continuous functions of x in the *closed* interval $(0, a)$.

Similarly, we represent the longitudinal electric intensity by a sine series

$$E_z = \sum e_n(z) \sin \frac{n\pi x}{a}, \quad n = 1, 2, 3, \dots \quad (18)$$

When the boundaries are not perfectly conducting, such a representation is possible only in the *open* interval $0 < x < a$ since the sine terms vanish at the ends of the interval while E_z does not. On the boundaries we use (14) and (15),

$$\begin{aligned} E_z(0, z) &= \frac{Z_1}{b} I_0(z) + \sum Z_1 N_n^{-1} I_n(z) \\ E_z(a, z) &= \frac{Z_2}{b} I_0(z) + \sum (-)^{n+1} Z_2 N_n^{-1} I_n(z) \end{aligned} \quad (19)$$

In the closed interval the series (18) represents a discontinuous function and therefore does not converge uniformly. Moreover, its coefficients diminish so slowly that after term by term differentiation, the series will diverge. Hence, we may not substitute this series in the first equation of the set (12) in order to obtain the relations between $V_n(z)$, $I_n(z)$, and $e_n(z)$ in the usual way. There is another way, however.

To obtain the equations for the principal mode we merely integrate (12) with respect to x from 0 to a and note that

$$\int_0^a E_z dx = V_0(z), \quad \int_0^a H_y dz = \frac{a}{b} I_0(z) \quad (20)$$

Thus we find

$$\begin{aligned} \frac{dV_0(z)}{dz} &= -\frac{j\omega\mu a}{b} I_0(z) + E_z(a, z) - E_z(0, z) \\ \frac{a}{b} \frac{dI_0(z)}{dz} &= -(g + j\omega\epsilon) V_0(z) \end{aligned} \quad (21)$$

We now substitute from (19) into (21),

$$\begin{aligned} \frac{dV_0(z)}{dz} &= -\left(\frac{j\omega\mu a}{b} + \frac{Z_1 + Z_2}{b}\right) I_0(z) - \sum \frac{Z_1 + (-)^n Z_2}{N_n} I_n(z) \\ \frac{dI_0(z)}{dz} &= -\frac{(g + j\omega\epsilon)b}{a} V_0(z), \end{aligned} \quad (22)$$

where the summation extends over the sequence $n = 1, 2, 3, \dots$. The classical form of telegraphist's equations is obtained if we neglect the

summation, that is, the coupling of the principal mode to the higher order modes.

It is worth noting that (18) for the longitudinal electric intensity has not been used.

5. UNIFORM STRIP TRANSMISSION LINES — HIGHER ORDER MODES

Telegraphist's equations for the typical higher order mode will be obtained if we multiply equations (12) by $N_m^{-1} \cos(m\pi x/a) dx dy$ and integrate over the cross-section of the strip line. Thus, we have

$$\int_0^a \int_0^b \frac{\partial E_x}{\partial z} N_m^{-1} \cos \frac{m\pi x}{a} dx dy = -j\omega\mu \int_0^a \int_0^b H_y N_m^{-1} \cos \frac{m\pi x}{a} dx dy + \int_0^a \int_0^b N_m^{-1} \cos \frac{m\pi x}{a} \frac{\partial E_z}{\partial x} dx dy \quad (23)$$

In the first and second terms of this equation we substitute from (15). The last term we integrate by parts. Thus we find

$$\frac{dV_m(z)}{dz} = -j\omega\mu I_m(z) - bN_m^{-1}[E_z(0, z) + (-)^{m+1}E_z(a, z)] + \int_0^a \int_0^b \frac{m\pi}{aN_m} E_z \sin \frac{m\pi x}{a} dx dy \quad (24)$$

To evaluate the last term we substitute from (13), integrate once more by parts, and substitute from (15),

$$\int_0^a \int_0^b \frac{m\pi}{aN_m} E_z \sin \frac{m\pi x}{a} dx dy = \frac{m\pi}{(g + j\omega\epsilon)aN_m} \int_0^a \int_0^b \frac{\partial H_y}{\partial x} \sin \frac{m\pi x}{a} dx dy = \frac{m\pi}{(g + j\omega\epsilon)aN_m} \left[bH_y(x, z) \sin \frac{m\pi x}{a} \Big|_0^a - \frac{m\pi}{a} \int_0^a \int_0^b H_y \cos \frac{m\pi x}{a} dx dy \right] = - \frac{m^2 \pi^2}{(g + j\omega\epsilon)a^2} I_m(z) \quad (25)$$

In view of this and (19), (24) becomes

$$\frac{dV_m(z)}{dz} = - \left[j\omega\mu + \frac{m^2 \pi^2}{(g + j\omega\epsilon)a^2} + \frac{(Z_1 + Z_2)b}{N_m^2} \right] I_m(z) + \frac{Z_1 + (-)^m Z_2}{N_m} I_0(z) + \sum' \frac{[Z_1 + (-)^{m+n} Z_2]b}{N_m N_n} I_n(z), \quad (26)$$

$$m = 1, 2, 3, \dots$$

where the prime after the summation sign indicates that the summation is to be extended over the sequence $n = 1, 2, 3, \dots$ except $n = m$.

Similarly, we obtain from the second equation of the set (12)

$$\frac{dI_m(z)}{dz} = -(g + j\omega\epsilon)V_m(z), \quad m = 1, 2, 3, \dots \quad (27)$$

Again it should be noted that in the above derivation we have not used the non-uniformly convergent series (18) for the longitudinal electric intensity. We could have used it. In that case, however, we would have been faced with the necessity of justifying certain steps. There is a theorem¹² to the effect that a uniformly convergent series may be integrated term by term. But the series (18) is not uniformly convergent. Hence, if we substitute from (18) in the last term of (24), we would have to prove that in this special instance the term by term integration is permissible. Actually the non-uniform convergence is only *sufficient* condition for term by term integration and *not a necessary* condition. Even the examples given in Reference 12 to show that some non-uniformly convergent series may not be integrated term by term in certain closed intervals are somewhat misleading without an explicit qualification; for it so happens that these series may be integrated term by term in slightly smaller intervals and correct results then obtained by passing to the limit. Nevertheless in the present case there is no reason why we should have complicated our derivation by using steps requiring special justification.

To obtain the longitudinal electric intensity we substitute from (15) and (18) in (13) and differentiate term by term. This differentiation is permissible if the series of derivatives is uniformly convergent. In the present case this means that the differentiation should be restricted to an open interval $0 < x < a$. Thus

$$e_n(z) = - \frac{n\pi}{(g + j\omega\epsilon)aN_n} \quad (28)$$

and

$$E_z = - \sum \frac{n\pi}{(g + j\omega\epsilon)aN_n} I_n(z) \sin \frac{n\pi x}{a} \quad (29)$$

For $x = 0$, a E_z may be obtained from (19). Very near the boundaries the series (29) converges very slowly. However, we know that E_z is very small there and normally we would not be interested in it. If we are, the best way to find it is by interpolation from the boundary values (19) and the interior values sufficiently far from the boundaries where the con-

vergence of (29) is more satisfactory. The slow convergence of (29) near the boundaries does not affect, of course, the validity of our telegraphist's equations.

6. STRIP TRANSMISSION LINE WITH VARIABLE CROSS-SECTION — THE PRINCIPAL MODE

In this section we shall consider strip transmission lines with variable cross-section, Fig. 4, which exemplify horns and waveguide to horn junctions. Here we can use either cartesian coordinates or curvilinear while in the parallel plane case the former seemed obviously the most

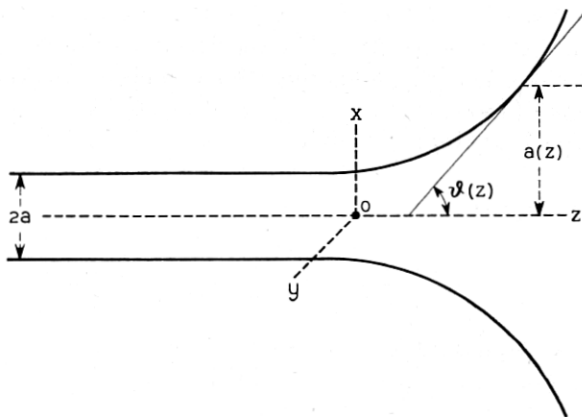

Fig. 4 — Strip transmission line with variable cross-section.

appropriate. It appears that cartesian coordinates are still the most convenient when the shape of the boundaries is arbitrary; in a subsequent section, however, we shall consider an example of curvilinear coordinates.

For the sake of simplicity we shall confine ourselves to the symmetric transmission line, both in geometry and in the impedance of the strips (that is, we shall assume $Z_2 = Z_1$). In the case of symmetric mode we can then insert a perfectly conducting plane $y=0z$ in the middle of the strip transmission line without disturbing the field.* Hence the boundary conditions will be

$$E_z(0, z) = 0, \quad E_t(a, z) = -ZH_y(a, z) \quad (30)$$

where Z is the surface impedance of the upper strip and E_t is the com-

* In the case of antisymmetric modes we can introduce an infinite impedance sheet.

ponent of electric intensity tangential to the strip. Since

$$E_t = E_z \cos \vartheta + E_x \sin \vartheta \quad (31)$$

where $\vartheta(z)$ is the angle between the axial plane and the plane tangent to the strip, the second boundary condition becomes

$$E_z(a, z) = -E_x \tan \vartheta - Z \sec \vartheta H_y(a, z) \quad (32)$$

In line with the heuristic argument propounded in Section 2, we shall express the field in the present strip line with variable distance $a(z)$ between the strips in terms of modes appropriate to the case of constant a and perfectly conducting boundaries. From the mathematical point of view this amounts to expanding the field intensities in a typical transverse plane in Fourier series in x . The coefficients of the series are to be determined from Maxwell's equations and boundary conditions. Thus we shall express E_x and H_y by series (15) and E_z by (18). The latter expression will hold only for $x < a$. When $x = a$, we find from (15) and (32)

$$\begin{aligned} E_z(a, z) = & -\frac{\tan \vartheta}{a} V_0(z) - \sum (-)^n N_n^{-1} \tan \vartheta V_n(z) \\ & - \frac{Z \sec \vartheta}{b} I_0(z) - \sum (-)^n N_n^{-1} Z \sec \vartheta I_n(z) \end{aligned} \quad (33)$$

To obtain the equations for principal waves we proceed as in Section 4 and integrate (12) with respect to x , taking into consideration (15). Thus we obtain (21). Then we substitute from (33) into (21),

$$\begin{aligned} \frac{dV_0(z)}{dz} = & -\left(\frac{j\omega\mu a}{b} + \frac{Z \sec \vartheta}{b}\right) I_0(z) - \frac{\tan \vartheta}{a} V_0(z) \\ & - \sum (-)^n N_n^{-1} Z \sec \vartheta I_n(z) - \sum (-)^n N_n^{-1} \tan \vartheta V_n(z) \end{aligned} \quad (34)$$

$$\frac{dI_0(z)}{dz} = -\frac{(g + j\omega\epsilon)b}{a} V_0(z)$$

Note the appearance of voltage transfer coefficients in addition to the mutual series impedances.

7. STRIP TRANSMISSION LINE WITH VARIABLE CROSS-SECTION — HIGHER ORDER MODES

The telegraphist's equations for higher order modes are obtained in much the same way as in Section 5. We must only remember that a is a function of z . The variation of a with z will introduce extra terms in our

final equations. Thus if we multiply the first equation of the set (12) by $N_n^{-1} \cos n\pi x/a$ and integrate over the cross-section of the line, we find first

$$\int_0^a \int_0^b \frac{\partial E_x}{dz} N_n^{-1} \cos \frac{n\pi x}{a} dx dy \quad (35)$$

$$= - \left[j\omega\mu + \frac{m^2}{(g + j\omega\epsilon)a^2} \right] I_m(z) + b(-)^m N_m^{-1} E_z(a, z)$$

Differentiating the series for E_x as given by (15), we obtain

$$\frac{\partial E_x}{\partial z} = \frac{1}{a} \frac{dV_0(z)}{dz} - \frac{a'(z)}{a^2} V_0(z)$$

$$+ \sum \left[\frac{dV_n}{dz} N_n^{-1} \cos \frac{n\pi x}{a} - \frac{N_n'(z)}{N_n^2} V_n \cos \frac{n\pi x}{a} \right. \quad (36)$$

$$\left. + \frac{n\pi x a'(z)}{N_n a^2} V_n \sin \frac{n\pi x}{a} \right]$$

Substituting from (36) in (35) and using (33), we have

$$\frac{dV_m}{dz} = -Z_{mm} I_m - \sum' Z_{mn} I_n - \sum {}^v T_{mn} V_n \quad (37)$$

where the prime denotes that the summation is extended over the sequence $n = 1, 2, 3, \dots$ except $n = m$, and

$$Z_{mn} = j\omega\mu + \frac{m^2 \pi^2}{(g + j\omega\epsilon)a^2} + bN_m^{-2} Z \sec \vartheta$$

$$Z_{mn} = (-)^{m+n} N_m^{-1} N_n^{-1} bZ \sec \vartheta \quad \text{if } m \neq n, m \neq 0, n \neq 0$$

$${}^v T_{mn} = (-)^{m+n} N_m^{-1} N_n^{-1} b \tan \vartheta$$

$$- \frac{n\pi a'(z)}{N_m N_n a^2} \int_0^a \int_0^b x \cos \frac{m\pi x}{a} \sin \frac{n\pi x}{a} dx dy \quad (38)$$

$$m \neq n, \quad m \neq 0, \quad n \neq 0,$$

$${}^v T_{mm} = N_m^{-2} b \tan \vartheta + N_m' N_m^{-1} - \frac{n\pi a'(z)b}{2N_m^2 a^2} \int_0^a x \sin \frac{2m\pi x}{a} dx$$

$$Z_{m0} = (-)^m Z N_m^{-1} \sec \vartheta, \quad m \neq 0$$

$${}^v T_{m0} = \frac{(-)^m b \tan \vartheta}{N_m a}$$

Similarly we find

$$\frac{dI_m}{dz} = -(g + j\omega\epsilon)V_m - \sum I_{mn}I_n \quad (39)$$

where

$${}^1T_{mn} = -\frac{n\pi a'(z)}{\alpha^2 N_m N_n} \int_0^a \int_0^a x \cos \frac{m\pi x}{a} \sin \frac{n\pi x}{a} dx dy, \quad m \neq n, \quad m \neq 0, \quad n \neq 0 \quad (40)$$

$${}^1T_{mm} = N_m' N_m^{-1} - \frac{m\pi a'(z)}{2\alpha^2 N_m^2} \int_0^a \int_0^b x \sin \frac{2m\pi x}{a} dx dy$$

$${}^1T_{m0} = 0$$

8. BENT STRIP TRANSMISSION LINES — THE PRINCIPAL MODE

Let us now suppose that the strip transmission line (with the guard strips) shown in Fig. 3 is bent uniformly in the xz plane. After bending, the x lines will be radii emerging from the axis of bending, the y lines will be straight and parallel to the axis, and the z lines will be circular arcs coaxial with the axis. The section of this structure by the plane $y = 0$ is shown in Fig. 5. The curved z axis of the bent coordinate system

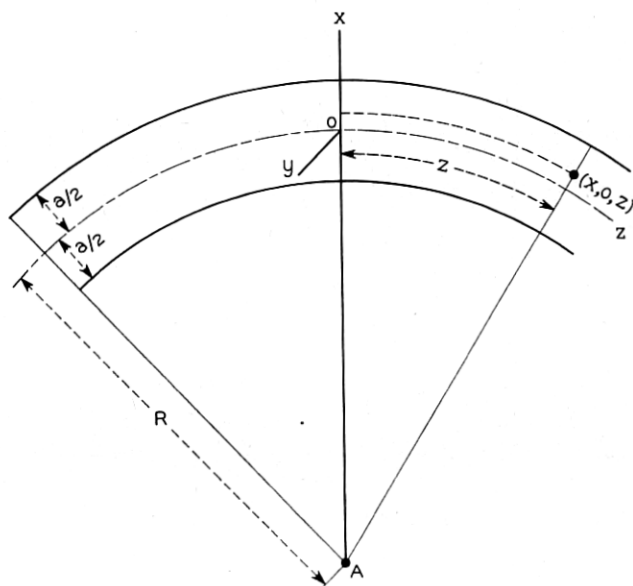

Fig. 5 — Uniformly bent strip transmission line.

will be chosen half way between the strips. The "distance" z between the radial xz planes will be measured along this curved z axis. The coordinate x is the shortest distance between the given point and the yOz coordinate surface. The differential distance between two points will then be

$$ds^2 = dx^2 + dy^2 + \left(1 + \frac{x}{R}\right)^2 dz^2 \quad (41)$$

where R is the radius of curvature of the z axis and is, in general, a function of z . The last term is obtained from the fact that the distances along the z lines between radial planes are proportional to the radii of curvature. Hence, if ds_z is the differential distance along a typical z line, the ratio ds_z/dz should equal the ratio $(R + x)/R$, or $ds_z = (R + x) dz/R$.

In this bent cartesian coordinate system Maxwell's equations take the following form

$$\begin{aligned} \frac{\partial E_x}{\partial z} &= -j\omega\mu \left(1 + \frac{x}{R}\right) H_y + \frac{\partial}{\partial x} \left[\left(1 + \frac{x}{R}\right) E_z \right] \\ \frac{\partial H_y}{\partial z} &= -j\omega\epsilon \left(1 + \frac{x}{R}\right) E_x + \frac{\partial}{\partial y} \left[\left(1 + \frac{x}{R}\right) H_z \right] \\ \frac{\partial E_y}{\partial z} &= j\omega\mu \left(1 + \frac{x}{R}\right) H_x + \frac{\partial}{\partial y} \left[\left(1 + \frac{x}{R}\right) H_z \right] \\ \frac{\partial H_x}{\partial z} &= j\omega\epsilon \left(1 + \frac{x}{R}\right) E_y + \frac{\partial}{\partial x} \left[\left(1 + \frac{x}{R}\right) H_z \right] \\ E_z &= \frac{1}{j\omega\epsilon} \left(\frac{\partial H_y}{\partial x} - \frac{\partial H_x}{\partial y} \right), \quad H_z = -\frac{1}{j\omega\mu} \left(\frac{\partial E_y}{\partial x} - \frac{\partial E_x}{\partial y} \right) \end{aligned} \quad (42)$$

There is no loss of generality in the apparent assumption that $g = 0$ since the general results may be obtained if we replace ϵ by $\epsilon + (g/j\omega)$. When the field is independent of the y coordinate, the equations become

$$\begin{aligned} \frac{\partial E_x}{\partial z} &= -j\omega\mu \left(1 + \frac{x}{R}\right) H_y + \frac{\partial}{\partial x} \left[\left(1 + \frac{x}{R}\right) E_z \right] \\ \frac{\partial H_y}{\partial z} &= -j\omega\epsilon \left(1 + \frac{x}{R}\right) E_x, \quad E_z = \frac{1}{j\omega\epsilon} \frac{\partial H_y}{\partial x} \end{aligned} \quad (43)$$

We shall now express the field in terms of modes appropriate to perfectly conducting plane strips. To do this we can use (15) provided we replace x by $x + (a/2)$, the transformation being needed because x is

now measured from a different reference surface. Thus we obtain

$$E_x = \frac{V_0(z)}{a} + \sum N_n^{-1} V_n(z) \cos \frac{n\pi}{a} \left(x + \frac{a}{2} \right), \quad n = 1, 2, 3, \dots \quad (44)$$

$$H_y = \frac{I_0(z)}{b} + \sum N_n^{-1} I_n(z) \cos \frac{n\pi}{a} \left(x + \frac{a}{2} \right)$$

where the normalization factors are still given by (16). The boundary conditions are

$$E_z \left(-\frac{a}{2}, z \right) = \frac{Z_1}{b} I_0(z) + \sum Z_1 N_n^{-1} I_n(z) \quad (45)$$

$$E_z \left(\frac{a}{2}, z \right) = -\frac{Z_2}{b} I_0(z) - \sum Z_2 (-)^n N_n^{-1} I_n(z)$$

Telegraphist's equations for the principal mode are obtained once more merely by integrating the first two equations of the set (43) with respect to x and using (44) and the boundary conditions (45). Thus we find

$$\frac{dV_0(z)}{dz} = - \left[\frac{j\omega\mu a}{b} + \frac{Z_1 + Z_2}{b} + \frac{(Z_2 - Z_1)a}{2Rb} \right] I_0(z) - \sum Z_{0n} I_n(z) \quad (46)$$

$$\frac{dI_0(z)}{dz} = -\frac{j\omega\epsilon b}{a} V_0(z) - \sum Y_{0n} V_n(z)$$

where

$$Z_{0n} = \frac{(-)^n Z_2 + Z_1}{N_n} + \frac{[(-)^n Z_2 - Z_1]a}{2RN_n} + \frac{j\omega\mu}{RN_n} \int_{-a/2}^{a/2} x \cos \frac{n\pi}{a} \left(x + \frac{a}{2} \right) dx \quad (47)$$

$$Y_{0n} = \frac{j\omega\epsilon b}{RaN_n} \int_{-a/2}^{a/2} x \cos \frac{n\pi}{a} \left(x + \frac{a}{2} \right) dx$$

These equations are valid even if the strips are bent non-uniformly so that R is a function of z .

9. BENT STRIP TRANSMISSION LINES — HIGHER ORDER MODES

To obtain telegraphist's equations for the higher order modes we multiply the first two equations of the set (43) by

$$N_m^{-1} \cos \frac{m\pi}{a} \left(x + \frac{a}{2} \right)$$

and integrate over the cross-section of the strip line. As in previous examples the last term in the first equation should be integrated by parts. Then we should substitute for E_z under the integral sign the third equation of the set (43) and once more integrate by parts. Finally, we should substitute for H_y its series representation. Thus we shall find

$$\frac{dV_m}{dz} = - \left[j\omega\mu + \frac{m^2\pi^2}{j\omega\epsilon a^2} + \frac{2(Z_1 + Z_2)}{a} + \frac{Z_2 - Z_1}{R} \right] I_m - \sum' Z_{mn} I_n \quad (48)$$

$$\frac{dI_m}{dz} = -j\omega\epsilon V_m - \sum' Y_{mn} V_n$$

where the summations are extended over the sequence $n = 0, 1, 2, \dots$ excepting $n = m$ and

$$\begin{aligned} Z_{mn} = & \frac{2[Z_1 + (-)^{m+n}Z_2]}{a} + \frac{(-)^{m+n}Z_2 - Z_1}{R} \\ & + \frac{1}{Ra} \left(j\omega\mu + \frac{mn\pi^2}{j\omega\epsilon a^2} \right) \int_{-a/2}^{a/2} x \cos \left[(m-n)\pi \left(\frac{x}{2} + \frac{1}{2} \right) \right] dx \\ & + \frac{1}{Ra} \left(j\omega\mu - \frac{mn\pi^2}{j\omega\epsilon a^2} \right) \int_{-a/2}^{a/2} x \cos \left[(m+n)\pi \left(\frac{x}{a} + \frac{1}{2} \right) \right] dx \end{aligned} \quad (49)$$

$$Y_{mn} = \frac{2j\omega\epsilon}{Ra} \int_{-a/2}^{a/2} x \cos \frac{m\pi}{a} \left(x + \frac{a}{2} \right) \cos \frac{n\pi}{a} \left(x + \frac{a}{2} \right) dx$$

for $n \neq 0, m$. For $n = 0$ the mutual parameters are given by (47).

In the open interval $-a/2 < x < a/2$ the series for H_y may be differentiated term by term. Hence, the longitudinal electric intensity may be obtained from the last equation of the set (43). Thus, between the boundaries we have

$$E_z(x, z) = - \sum (n\pi/a) N_n^{-1} I_n(z) \sin \frac{n\pi}{a} \left(x + \frac{a}{2} \right), \quad (50)$$

$$- a/2 < x < a/2$$

On the boundaries we have (45).

The above equations are still valid when R is a function of z ; but a and b must be constants.

10. EXPANDING STRIP TRANSMISSION LINES IN CURVILINEAR COORDINATES — A CASE IN WHICH MAXWELL'S EQUATIONS ARE NOT SEPARABLE

The separate sets of terms in the series representing various field components in all preceding problems satisfied Maxwell's equations. The

entire series were required to satisfy the boundary conditions. In the present section we shall express the field in terms of sets of functions which individually *do not* satisfy Maxwell's equations and which *may or may not* satisfy the boundary conditions. The example we are about to consider will illustrate a method for solving Maxwell's equations, when the variables are not separable, by reducing them to generalized telegraphist's equations.

Let us assume that the boundaries of the expanding portion of the strip transmission line in Fig. 4 are circular cylinders tangential to the plane boundaries to the left of the xOy plane. This is, of course, a special case of the problem treated in Sections 6 and 7. In the present section, however, we shall use curvilinear coordinates. In such coordinates Maxwell's equations are

$$\begin{aligned}
 \frac{\partial(e_1 E_u)}{\partial w} &= -j\omega\mu(e_3 e_1 / e_2)(e_2 H_v) + \frac{\partial(e_3 E_w)}{\partial u} \\
 \frac{\partial(e_2 H_v)}{\partial w} &= -j\omega\epsilon(e_2 e_3 / e_1)(e_1 E_u) + \frac{\partial}{\partial v}(e_3 H_w) \\
 \frac{\partial(e_2 E_v)}{\partial w} &= j\omega\mu(e_2 e_3 / e_1)(e_1 H_u) + \frac{\partial}{\partial v}(e_3 E_w) \\
 \frac{\partial(e_1 H_u)}{\partial w} &= j\omega\epsilon(e_3 e_1 / e_2)(e_2 E_v) + \frac{\partial}{\partial u}(e_3 H_w)
 \end{aligned} \tag{51}$$

$$E_w = \frac{1}{j\omega\epsilon e_1 e_2} \left[\frac{\partial(e_2 H_v)}{\partial u} - \frac{\partial(e_1 H_u)}{\partial v} \right]$$

$$H_w = \frac{1}{j\omega\mu e_1 e_2} \left[\frac{\partial(e_1 E_u)}{\partial v} - \frac{\partial(e_2 E_v)}{\partial u} \right]$$

These equations have been arranged in a form convenient for problems in which wave propagation takes place along the w lines. In some cases it is convenient to treat the products $e_1 E_u$, $e_2 E_v$, $e_1 H_u$, $e_2 H_v$ rather than the field components themselves as dependent variables and the parentheses around these products in the preceding equations are intended to call attention to this fact.

The choice of a particular coordinate system for solving a physical problem depends on various factors. The cartesian system chosen in Sections 6 and 7 is good for several reasons: Maxwell's equations have a particularly simple form, boundary conditions are easy to express for almost arbitrary boundaries, the basic transverse field patterns con-

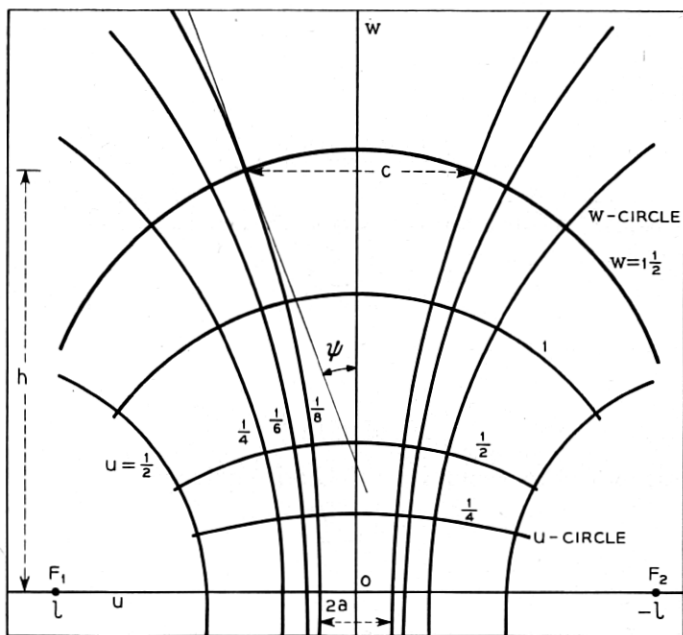

Fig. 6 — Biaxial coordinates.

form to those in waveguides of uniform cross-section. For this last reason, the cartesian system is particularly convenient for the analysis of junction sections between two waveguides of rectangular cross-section. Biaxial coordinates¹³ are more convenient in some respects for the analysis of junctions between two-dimensional waveguides and two-dimensional horns, Fig. 6, although we are not prepared to say that they are more convenient than cartesian coordinates when all factors are taken into consideration. Here we shall use biaxial coordinates solely to illustrate the conversion of Maxwell's equations in curvilinear coordinates into generalized telegraphist's equations.

Biaxial coordinate system consists of two orthogonal systems of circular cylinders perpendicular to a system of parallel planes. A section by one of these planes is shown in Fig. 6. Circles of one system are non-intersecting and their centers lie on the horizontal axis. Circles of the other system intersect at the foci F_1 and F_2 ; their centers lie on the vertical axis. The non-intersecting circles will be called the w -lines (lines of constant u and varying w), and the intersecting circles the u -lines. The coordinate u is the shortest distance between the w -circle and the vertical axis; w is the intercept of the u -circular arc on the vertical axis (each

u -circle will be split for our purposes into two arcs, one above and the other below the focal line F_1F_2).

The radius of a typical w -circle is

$$\frac{1}{2} \ell \left(\frac{\ell}{u} - \frac{u}{\ell} \right)$$

and the distance between the center and the vertical axis

$$\frac{1}{2} \ell \left(\frac{\ell}{u} + \frac{u}{\ell} \right)$$

The radius of a u -circle is

$$\frac{1}{2} \ell \left(\frac{w}{\ell} + \frac{\ell}{w} \right)$$

and the distance of its center from the horizontal axis

$$\frac{1}{2} \left(\frac{w}{\ell} - \frac{\ell}{w} \right)$$

Depending on whether this distance is positive or negative, the center is above or below the horizontal axis. In this coordinate system

$$e_1 = \frac{1 + (w/\ell)^2}{1 + (uw/\ell^2)^2}, \quad e_2 = 1, \quad e_3 = \frac{1 - (u/\ell)^2}{1 + (uw/\ell^2)^2} \quad (52)$$

A section of a waveguide to horn junction is characterized by the following parameters: the length h , the width of the narrow aperture $2a$, the width of the wide aperture $2c$, and the horn angle 2ψ at the wide aperture. If h/a and ψ are given, then

$$c/a = 1 + (h/a) \tan \frac{1}{2}\psi, \quad \ell/a = [1 + (2h/a \sin \psi)]^{1/2} \quad (53)$$

From the last equation we determine the semi-focal distance ℓ for the coordinate system. The coordinate w_0 of the "wave-front" at the wide aperture may be obtained from

$$aw_0/\ell^2 = \tan \frac{1}{2}\psi \quad (54)$$

As in Sections 6 and 7 we shall consider those modes for which the field is independent of v and for which (51) becomes

$$\begin{aligned} \frac{\partial(e_1 E_u)}{\partial w} &= -j\omega\mu e_1 e_3 H_v + \frac{\partial}{\partial u} (e_3 E_w) \\ \frac{\partial H_v}{\partial w} &= -j\omega\epsilon (e_3/e_1)(e_1 E_u), \quad E_w = \frac{1}{j\omega\epsilon e_1} \frac{\partial H_v}{\partial u} \end{aligned} \quad (55)$$

We have already examined several cases with imperfectly conducting boundaries and in the present example we shall assume that the boundaries are perfectly conducting. We shall confine ourselves to symmetric modes for which E_u is perpendicular to the vw plane. We shall express our field in the form analogous to (15); thus

$$\begin{aligned} e_1 E_w &= \frac{V_0(w)}{a} + \sum N_n^{-1} V_n(w) \cos \frac{n\pi u}{a} \\ H_v &= \frac{I_0(w)}{b} + \sum N_n^{-1} I_n(w) \cos \frac{n\pi u}{a} \end{aligned} \quad (56)$$

$$N_n^2 = ab/2, \quad n = 1, 2, 3, \dots$$

where b is the width of the strips. Substituting in the last equation of the set (55) we find

$$j\omega\epsilon e_1 E_w = -\sum \frac{n\pi}{aN_n} I_n(w) \sin \frac{n\pi u}{a} \quad (57)$$

The boundary conditions are thus satisfied automatically. If we integrate the first series in the set (56) along a typical u -line, we obtain

$$\int_0^a e_1 E_u du = \int_0^a E_u ds_u = V_0(w) \quad (58)$$

Hence, $V_0(w)$ is the transverse voltage from the middle plane of the strip line to the upper strip, measured along a u -line. It should be noted that in the narrow aperture $w = 0$, $u = x$, $e_1 = 1$ and series (56) are identical with (15).

To obtain telegraphist's equations for the principal mode we integrate the first two equations of the set (55) along a u -line and substitute from (56); thus we have

$$\begin{aligned} \frac{dV_0}{dw} &= -Z_{00}I_0 - Z_{01}I_1 - Z_{02}I_2 - \dots \\ \frac{dI_0}{dw} &= -Y_{00}V_0 - Y_{01}V_1 - Y_{02}V_2 - \dots \end{aligned} \quad (59)$$

where

$$\begin{aligned} Z_{00} &= \frac{j\omega\mu}{b} \int_0^a e_1 e_3 du, & Y_{00} &= \frac{j\omega\epsilon b}{a} \int_0^a \frac{e_3}{e_1} du \\ Z_{0n} &= \frac{j\omega\mu}{N_n} \int_0^a e_1 e_3 \cos \frac{n\pi u}{a} du, & Y_{0n} &= \frac{j\omega\epsilon b}{N_n} \int_0^a \frac{e_3}{e_1} \cos \frac{n\pi u}{a} du, \end{aligned} \quad (60)$$

$n > 0$

The integrals for Z_{00} , Y_{00} , and Y_{0n} may be expressed in terms of elementary functions, and the integrals for Z_{0n} by power series since

$$\begin{aligned} e_1 e_3 &= [1 + (w/\ell)^2][1 - (u/\ell)^2][1 + (uw/\ell^2)^2]^{-2} \\ &= [1 + (w/\ell)^2][1 - (u/\ell)^2][1 - 2(uw/\ell^2)^2 + 3(uw/\ell^2)^4 - \dots] \end{aligned} \quad (61)$$

In practical cases u/ℓ and uw/ℓ^2 are relatively small and a few terms of the series will suffice.

To obtain the corresponding equations for the higher order modes we should multiply the first two equations of the set (55) by $N_m^{-1} \cos(m\pi u/a)$ and integrate over the cross-section of the strip line by the w surface. Thus, we find

$$\begin{aligned} Z_{mn} &= \frac{j\omega\mu b}{N_m N_n} \int_0^a e_1 e_3 \cos \frac{m\pi u}{a} \cos \frac{n\pi u}{a} du \\ &\quad + \frac{mn\pi^2 b}{j\omega\epsilon a^2 N_m N_n} \int_0^a \frac{e_3}{e_1} \sin \frac{m\pi u}{a} \sin \frac{n\pi u}{a} du \end{aligned} \quad (62)$$

$$Y_{mn} = \frac{j\omega\epsilon b}{N_m N_n} \int_0^a \frac{e_3}{e_1} \cos \frac{m\pi u}{a} \cos \frac{n\pi u}{a} du$$

for all m, n not equal to zero.

11. TRANSVERSE ELECTRIC WAVES BETWEEN PARALLEL PLANES

Let us now see what happens in the case of TE modes. Again we shall consider the simplest case, the case of parallel planes, Fig. 3, and assume that the field is independent of the y coordinates. The only non-vanishing field components are E_y , H_x and H_z , and Maxwell's equations become

$$\frac{\partial E_y}{\partial z} = j\omega\mu H_x, \quad \frac{\partial H_x}{\partial z} = (g + j\omega\epsilon)E_y + \frac{\partial H_z}{\partial x} \quad (63)$$

$$H_z = -\frac{1}{j\omega\mu} \frac{\partial E_y}{\partial x}$$

For perfectly conducting planes the general solution is of the following form

$$E_y = \sum N_n^{-1} V_n(z) \sin(n\pi x/a), \quad H_x = -\sum N_n^{-1} I_n(z) \sin(n\pi x/a) \quad (64)$$

where the normalizing factors are given by (16). We now assume that between ($0 < x < a$), the imperfectly conducting planes the general solution has still the same form. Putting it differently we expand the new solution in a sine series. Since the sine terms vanish on the boundaries,

the series will represent the new solution only between the boundaries. Since these series represent discontinuous functions, their coefficients will ultimately vary as $1/n$; therefore the derivative series will diverge. Hence, we cannot obtain H_z by substituting from (64) into the third equation of the set (63). For this reason, we assume an independent series for H_z ,

$$H_z = \sum N_n^{-1} i_n(z) \cos(n\pi x/a) \quad (65)$$

On the boundaries the ratios of the tangential electric and magnetic intensities equal surface impedances of the boundaries, with appropriate signs,

$$\begin{aligned} E_y(0, z) &= -Z_1 H_z(0, z) = -\sum Z_1 N_n^{-1} i_n(z) \\ E_y(a, z) &= Z_2 H_z(a, z) = \sum (-)^n Z_2 N_n^{-1} i_n(z) \end{aligned} \quad (66)$$

The cosine series (65) represents a continuous function and its coefficients will decrease fast enough to make the derivative series convergent. So we substitute from (64) and (65) in (63), combine the terms containing similar sine terms, and equate the coefficients of the resulting sine series to zero. Thus we obtain

$$\frac{dV_n(z)}{dz} = -j\omega\mu I_n(z), \quad \frac{dI_n(z)}{dz} = -(g + j\omega\epsilon)V_n(z) + \frac{n\pi}{a} i_n(z) \quad (67)$$

We now multiply the third equation in the set (63) by $N_m^{-1} \cos(m\pi x/a)$ and integrate,

$$\begin{aligned} \int_0^b \int_0^a H_z N_m^{-1} \cos \frac{m\pi x}{a} dx dy \\ = -\frac{1}{j\omega\mu} \int_0^b \int_0^a \frac{\partial E_y}{\partial x} N_m^{-1} \cos \frac{m\pi x}{a} dx dy \end{aligned} \quad (68)$$

On the left we substitute from (65), and on the right we integrate by parts,

$$\begin{aligned} i_m(z) &= -\frac{b}{j\omega\mu N_m} \cos \frac{m\pi x}{a} E_y(x, z) \Big|_0^a \\ &\quad - \frac{1}{j\omega\mu} \int_0^b \int_0^a E_y \frac{m\pi}{aN_m} \sin \frac{m\pi x}{a} dx dy \end{aligned} \quad (69)$$

In the first term on the right we substitute from (66). In the second term we substitute the series for E_y . Since this series is not uniformly convergent in the closed interval $0 \leq x \leq a$, we cannot be sure that we shall

get the right answer by integrating the series term by term. What we can do is to integrate in a slightly smaller interval in which the series converges uniformly, and then pass to the limit. In the present case the answer turns out to be the same as that obtained when we integrate term by term in the closed interval. Thus we find

$$i_m(z) = -b \sum_n \frac{Z_1 + (-)^{m+n} Z_2}{j\omega\mu N_m N_n} i_n(z) - \frac{m\pi}{j\omega\mu a} V_m(z) \quad (70)$$

If we solve this set of equations for $i_n(z)$ and substitute in (67), we shall obtain telegraphist's equations.

Rearranging the terms in (70), we have

$$\left[1 + \frac{2(Z_1 + Z_2)}{j\omega\mu a} \right] i_m(z) + \sum' \frac{2[Z_1 + (-)^{m+n} Z_2]}{j\omega\mu a} i_n(z) = -\frac{m\pi}{j\omega\mu a} V_m(z) \quad (71)$$

Neglecting the summation, we obtain an approximate solution

$$i_n(z) = -\frac{m\pi}{j\omega\mu a} \left[1 + \frac{2(Z_1 + Z_2)}{j\omega\mu a} \right]^{-1} V_m(z) \quad (72)$$

and approximate telegraphist's equations,

$$\frac{dV_n}{dz} = -j\omega\mu I_n, \quad \frac{dI_n}{dz} = -\left[g + j\omega\epsilon + \frac{n^2 \pi^2}{j\omega\mu a^2 + 2(Z_1 + Z_2)a} \right] V_n \quad (73)$$

Instead of solving (70) for $i_n(z)$ we can obtain $V_m(z)$ from (70) and substitute it in (67), after replacing n in (73) by m .

12. WAVES ON INFINITE CONDUCTORS

In this section we shall consider waves on two semi-infinite conductors tapering to a point, Fig. 7(a), and waves outside a certain sphere (S), Fig. 7(b), which encloses the terminals of conductors which are not tapered to a point. In the latter case the sphere (S) will enclose a source of power; in the former case we assume an idealized point source of power at the origin O . For simplicity we shall assume that the structure possesses circular symmetry about OA and plane symmetry about the plane perpendicular to OA at O . In this case there will be waves in which the magnetic lines are circles coaxial with the axis of the structure. In

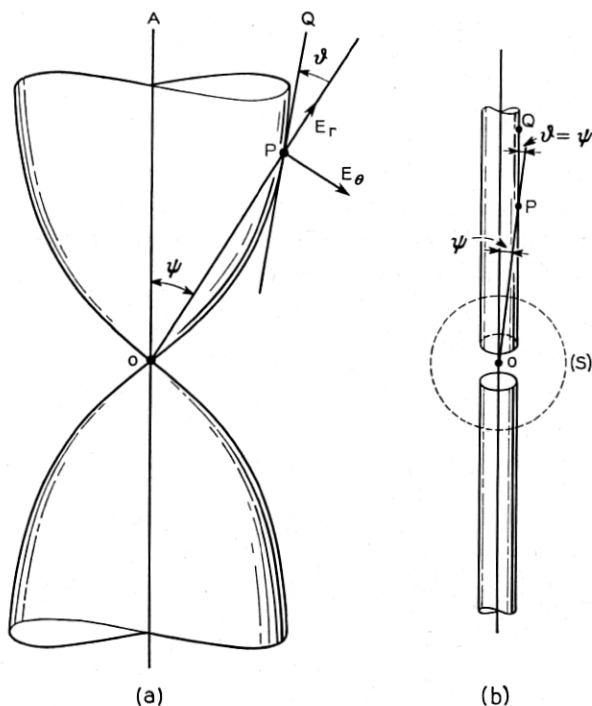

Fig. 7 — Infinite conductors excited by a point source (a) and by a source of finite size (b).

spherical coordinates the appropriate field equations are

$$\frac{\partial}{\partial r}(rE_{\theta}) = -j\omega\mu(rH_{\varphi}) + \frac{\partial E_r}{\partial \theta}, \quad \frac{\partial}{\partial r}(rH_{\varphi}) = -(g + j\omega\epsilon)(rE_{\theta}) \quad (74)$$

$$E_r = \frac{1}{(g + j\omega\epsilon)r^2} \frac{1}{\sin \theta} \frac{\partial}{\partial \theta} (\sin \theta rH_{\varphi})$$

Let P be a typical point on the upper half of the structure and ψ be the angle between the radius OP and the axis OA . Let ϑ be the angle from the radius to the tangent plane PQ . Then the boundary conditions are

$$E_r(r, \psi) \cos \vartheta - E_{\theta}(r, \psi) \sin \vartheta = ZH_{\varphi}(r, \psi) \quad (75)$$

$$E_r(r, \pi - \psi) \cos \vartheta + E_{\theta}(r, \pi - \psi) \sin \vartheta = -ZH_{\varphi}(r, \pi - \psi)$$

where Z is the surface impedance. Thus, at the surface of each conductor the radial electric intensity may be expressed in terms of the meridian

electric intensity and the magnetic intensity

$$\begin{aligned} E_r(r, \psi) &= E_\theta(r, \psi) \tan \vartheta + Z \sec \vartheta H_\varphi(r, \psi) \\ E_r(r, \pi - \psi) &= -E_r(r, \psi) \end{aligned} \quad (76)$$

Let us further confine ourselves to the symmetric modes in which the currents passing through the cross-sections of the upper and the lower conductors equidistant from 0 are equal and similarly directed. Then we shall represent the field by the following series

$$\begin{aligned} rE_\theta &= \frac{V_0(r)}{N_0(r) \sin \theta} + \sum V_n(r) N_n^{-1}(r) \frac{\partial M_n(\cos \theta)}{\partial \theta}, \\ &\psi \leq \theta \leq \pi - \psi \\ rH_\varphi &= \frac{I_0(r)}{2\pi \sin \theta} + \sum I_n(r) N_n^{-1}(r) \frac{\partial M_n(\cos \theta)}{\partial \theta}, \\ &\psi \leq \theta \leq \pi - \psi \end{aligned} \quad (77)$$

$$E_r = -\sum \frac{n(n+1)}{(g + j\omega\epsilon)r^2 N_m(r)} I_n(r) M_n(\cos \theta), \quad \psi < \theta < \pi - \psi$$

where

$$M_n(\cos \theta) = \frac{1}{2} [P_n(\cos \theta) - P_n(-\cos \theta)] \quad (78)$$

and the P -functions are Legendre functions. The summations are extended over the roots n of the following equation:

$$M_n(\cos \psi) = 0 \quad (79)$$

The normalizing factors are

$$\begin{aligned} N_0 &= \int_\psi^{\pi-\psi} \frac{d\theta d\varphi}{\sin \theta} = 2 \log \cot \frac{\psi}{2} \\ N_n^2 &= 2\pi \int_\psi^{\pi-\psi} \left[\frac{\partial}{\partial \theta} M_n(\cos \theta) \right]^2 \sin \theta d\theta \\ &= 2\pi n(n+1) \int_\psi^{\pi-\psi} M_n(\cos \theta)]^2 \sin \theta d\theta \end{aligned} \quad (80)$$

Each individual term in (77) will satisfy Maxwell's equations and the boundary conditions if the conductors happen to be perfectly conducting cones. Otherwise we need the entire series. The function $V_0(r)$ is the transverse voltage between the conductors along a typical meridian; $I_0(r)$ is the current in the upper conductor associated with the principal wave. The remaining functions, $V_n(r)$ and $I_n(r)$, are proportional to the

electric and magnetic intensities of various modes. In view of (77) the boundary conditions become

$$E_r(r, \psi) = \frac{\tan \vartheta}{rN_0 \sin \psi} V_0(r) + \sum \frac{\tan \vartheta}{rN_n} \frac{\partial M_n(\cos \psi)}{\partial \psi} V_n(r) + \frac{Z \sec \vartheta}{2\pi r \sin \psi} I_0(r) + \sum \frac{Z \sec \vartheta}{rN_n} \frac{\partial M_n(\cos \psi)}{\partial \psi} I_n(r) \tag{81}$$

Equations for the principal mode are obtained as in previous examples by integrating the first two field equations (74). Thus, we find

$$\frac{dV_0(r)}{dr} = -\frac{j\omega\mu}{\pi} \log \cot \frac{\psi}{2} I_0(r) + E_r(r, \pi - \psi) - E_r(r, \psi)$$

$$\frac{dI_0(r)}{dr} = -\frac{\pi(g + j\omega\epsilon)}{\log \cot (\psi/2)} V_0(r) \tag{82}$$

Substituting from (81), we obtain the final result.

To obtain the equations for the higher mode we shall multiply the field equations by the normalized characteristic functions and integrate. It is important to remember that ψ, ϑ and therefore n and N_n are functions of r . On one occasion we shall have to integrate by parts as follows

$$\iint N_m^{-1} \frac{\partial M_m(\cos \theta)}{\partial \theta} \sin \theta \frac{\partial E_r}{\partial \theta} d\theta d\varphi$$

$$= 2\pi N_m^{-1} E_r(r, \theta) \frac{\partial M_m(\cos \theta)}{\partial \theta} \sin \theta \Big|_{\psi}^{\pi-\psi} + \iint N_m^{-1} E_r(r, \theta) m (m + 1) M_m(\cos \theta) \sin \theta d\theta d\varphi$$

$$= -\frac{m(m + 1)}{(g + j\omega\epsilon)r^2} I_m(r) + 2\pi N_m^{-1} E_r(r, \theta) \frac{\partial M_m(\cos \theta)}{\partial \theta} \sin \theta \Big|_{\psi}^{\pi-\psi}$$

On another occasion we have to take into consideration the above-mentioned dependence of n and N_n on r ,

$$\iint N_m^{-1} \frac{\partial M_m(\cos \theta)}{\partial \theta} \sin \theta \frac{\partial}{\partial r} \left[V_n(r) N_n^{-1}(r) \frac{\partial M_n(\cos \theta)}{\partial \theta} \right] d\theta d\varphi$$

$$= V_n(r) \iint N_m^{-1} \frac{\partial M_m(\cos \theta)}{\partial \theta} \frac{\partial}{\partial r} \left[N_n^{-1}(r) \frac{\partial M_n(\cos \theta)}{\partial \theta} \right] \sin \theta d\theta d\varphi, \quad \text{if } n \neq m, \tag{84}$$

$$= \frac{\partial V_m(r)}{\partial r} + V_m(r) \iint N_m^{-1} \frac{\partial M_m(\cos \theta)}{\partial \theta} \frac{\partial}{\partial r} \left[N_m^{-1}(r) \frac{\partial M_m(\cos \theta)}{\partial \theta} \right] \sin \theta d\theta d\varphi$$

if $n = m$.

In the end we shall obtain (11) with the following values of the transmission line parameters,

$$\begin{aligned}
 Z_{00} &= \frac{j\omega\mu}{\pi} \log \cot (\psi/2) + \frac{Z \sec \vartheta}{\pi 2/\sin \psi} \\
 Y_{00} &= \frac{\pi(g + j\omega)}{\log \cot (\psi/2)}, \quad I_{r_{00}} = 0 \\
 {}^v T_{00} &= \frac{\tan \vartheta}{r \sin \psi \log \cot (\psi/2)} \\
 {}^v T_{0n} &= \frac{2 \tan \vartheta}{r N_n} \frac{\partial M_n(\cos \psi)}{\partial \psi}, \quad n \neq 0 \\
 Z_{0n} &= \frac{2Z \sec \vartheta}{r N_n} \frac{\partial M_n(\cos \psi)}{\partial \psi} \\
 Y_{0n} &= I_{r_{0n}} = 0, \quad n \neq 0 \\
 Z_{mm} &= j\omega\mu + \frac{m(m+1)}{(g + j\omega\epsilon)r^2} + \frac{4\pi Z \sec \vartheta}{r N_m^2} \left[\frac{\partial M_m(\cos \psi)}{\partial \psi} \right]^2 \sin \psi, \\
 & \qquad \qquad \qquad m \neq 0 \\
 Z_{mn} &= \frac{4\pi Z \sec \vartheta}{r N_m N_n} \frac{\partial M_m(\cos \psi)}{\partial \psi} \frac{\partial M_n(\cos \psi)}{\partial \psi} \sin \psi, \quad n \neq m, \\
 & \qquad \qquad \qquad m \neq 0 \quad (85) \\
 {}^v T_{mn} &= \frac{4\pi \tan \vartheta}{r N_m N_n} \frac{\partial M_m(\cos \psi)}{\partial \psi} \frac{\partial M_n(\cos \psi)}{\partial \psi} \sin \psi \\
 & \quad + \iint N_m^{-1} \frac{\partial M_m(\cos \theta)}{\partial \theta} \frac{\partial}{\partial r} \left[N_n^{-1}(r) \frac{\partial M_n(\cos \psi)}{\partial r} \right] \sin \theta \, d\theta \, d\varphi \\
 & \qquad \qquad \qquad m \neq 0, \quad n \neq 0; \\
 Z_{m0} &= Z_{0m}, \quad Z_{mn} = Z_{nm}, \\
 V_{r_{m0}} &= \frac{2\pi \tan \vartheta}{r N_m \log \cot (\psi/2)} \frac{\partial M_n(\cos \psi)}{\partial \psi}, \quad m \neq 0 \\
 Y_{mm} &= g + j\omega\epsilon, \quad Y_{mn} = Y_{nm} = 0, \quad n \neq m \\
 {}^i T_{mn} &= \iint N_m^{-1} \frac{\partial M_m(\cos \theta)}{\partial \theta} \frac{\partial}{\partial r} \left[N_n^{-1}(r) \frac{\partial M_n(\cos \psi)}{\partial r} \right] \sin \theta \, d\theta \, d\varphi. \\
 & \qquad \qquad \qquad m \neq 0, \quad n \neq 0 \\
 {}^i T_{m0} &= 0
 \end{aligned}$$

13. WAVES ON SEMI-INFINITE CONDUCTORS

The telegraphist's equations for a single conductor, the upper conductor let us say, may be obtained by a few modifications of the equations in the preceding section. There will be no terms outside the summation signs in (77). The function $M_n(\cos \theta)$ should be replaced by $P_n(-\cos \theta)$. The integrals with respect to θ should be evaluated from $\theta = \psi$ to $\theta = \pi$ rather than from $\theta = \psi$ to $\pi - \psi$.

14. WAVES OVER A PLANE IMPEDANCE SHEET

Under some conditions a plane earth may be approximated by an impedance sheet. Such a sheet is a cone of angle $\psi = \pi/2$ and the telegraphist's equations for it will be obtained if we replace $M_n(\cos \theta)$ by $P_{2n+1}(\cos \theta)$ where $n = 0, 1, 2, \dots$. The integrals should be calculated over the upper hemisphere. Of course, $\vartheta = 0$, and hence all the voltage and current transfer coefficients vanish.

The normalization factor becomes

$$N_n = \frac{\sqrt{2\pi} \sqrt{n(n+1)}}{\sqrt{2n+1}} \quad (86)$$

If the distributed self-impedance of a typical mode is expressed as

$$Z_{mm} = Z_{mm}^0 + Z_{mm}' \quad (87)$$

where Z_{mm}^0 is the distributed self-impedance for a perfectly conducting sheet and Z_{mm}' is due to the finite surface impedance, then

$$\begin{aligned} Z_{mm}^0 &= j\omega\mu + \frac{m(m+1)}{(g + j\omega\epsilon)r^2} \\ Z_{mm}' &= (-)^{m+1} \frac{(2m+1)(1.3.5 \dots m)^2 Z}{m(m+1)[2.4.6 \dots (m-1)]^2 r} \end{aligned} \quad (88)$$

The distributed mutual impedances are given by

$$Z_{mn} = \sqrt{Z_{mm}' Z_{nn}'} \quad (89)$$

The distributed admittances are independent of the surface impedance of the sheet; hence

$$Y_{mn} = g + j\omega\epsilon, \quad Y_{mn} = 0 \quad \text{if } m \neq n \quad (90)$$

In all these equations m and n are odd integers.

15. DERIVATION OF APPROXIMATE TELEGRAPHIST'S EQUATIONS FOR THE TE_{11} MODE IN A CIRCULAR WAVEGUIDE-TO-HORN JUNCTION

It is probably safer not to make approximations sooner than absolutely necessary provided we are willing to tolerate a mass of detail which later turns out to be unnecessary. Still, if the technique of conversion of Maxwell's equations into telegraphist's equations is thoroughly understood, it may be possible to make *ab initio* approximations without undue risk of omitting something more important than we are willing to neglect. To illustrate such *ab initio* approximations we shall obtain telegraphist's equations for the dominant mode in a gentle waveguide-to-horn circular junction. At the start we shall neglect all the coupling coefficients except those between TE_{11} and TM_{11} modes. Even these will be retained only part of the way in order to explain what we should do if we neglect them from the beginning. In the next section we shall discuss cases in which we *should not neglect* all the coupling coefficients.

First of all we shall exhibit azimuthal variation of the field.

$$\begin{aligned}
 E_\rho &= \pi^{-1/2} \hat{E} \sin \varphi \\
 H_\varphi &= \pi^{-1/2} \hat{H}_\varphi \sin \varphi \\
 E_\varphi &= \pi^{-1/2} \hat{E}_\varphi \cos \varphi \\
 H_\rho &= \pi^{-1/2} \hat{H}_\rho \cos \varphi \\
 E_z &= \pi^{-1/2} \hat{E}_z \sin \varphi \\
 H_z &= \pi^{-1/2} \hat{H}_z \cos \varphi
 \end{aligned} \tag{91}$$

The factor $\pi^{-1/2}$ has been introduced to normalize the sine and cosine. If we retain only the first radial TE and TM modes, we have

$$\begin{aligned}
 \hat{E}_\rho &\cong N^{-1}V(z)(\chi\rho)^{-1}J_1(\chi\rho) + \bar{N}^{-1}\bar{V}(z)J_1'(\bar{\chi}\rho) \\
 \hat{H}_\varphi &\cong N^{-1}I(z)(\chi\rho)^{-1}J_1(\chi\rho) + \bar{N}^{-1}\bar{I}(z)J_1'(\bar{\chi}\rho) \\
 \hat{E}_\varphi &\cong N^{-1}V(z)J_1'(\chi\rho) + \bar{N}^{-1}\bar{V}(z)(\bar{\chi}\rho)^{-1}J_1(\bar{\chi}\rho) \\
 \hat{H}_\rho &\cong N^{-1}I(z)J_1'(\chi\rho) - \bar{N}^{-1}\bar{I}(z)(\bar{\chi}\rho)^{-1}J_1(\bar{\chi}\rho)
 \end{aligned} \tag{92}$$

where

$$\chi a = 1.841 \dots \quad \bar{\chi} a = 3.83 \dots \tag{93}$$

and

$$\begin{aligned}
 N^2 &= \int_0^a ([J_1'(\chi\rho)]^2 + (\chi\rho)^{-2}[J_1(\chi\rho)]^2)\rho \, d\rho \\
 &= \int_0^a [J_1(\chi\rho)]^2 \rho \, d\rho = \frac{1}{2} a^2 \left[1 - \frac{1}{(1.84)^2} \right] [J_1(1.84)]^2 = (0.345a)^2
 \end{aligned} \tag{94}$$

$$\begin{aligned}
 \bar{N}^2 &= \int_0^a ([J_1'(\bar{\chi}\rho)]^2 + (\bar{\chi}\rho)^{-2}[J_1(\bar{\chi}\rho)]^2)\rho \, d\rho \\
 &= \int_0^a [J_1(\bar{\chi}\rho)]^2 \rho \, d\rho = \frac{1}{2} a^2 [J_0(3.83)]^2 = (0.285a)^2.
 \end{aligned}$$

Maxwell's transmission equations for transverse field components in cylindrical coordinates are

$$\begin{aligned}
 \frac{\partial E_\rho}{\partial z} &= -j\omega\mu H_\varphi + \frac{\partial E_z}{\partial \rho} \\
 \frac{\partial H_\varphi}{\partial z} &= -j\omega\epsilon E_\rho + \frac{\partial H_z}{\rho\partial\varphi} \\
 \frac{\partial E_\varphi}{\partial z} &= j\omega\mu H_\rho + \frac{\partial E_z}{\rho\partial\varphi} \\
 \frac{\partial H_\rho}{\partial z} &= j\omega\epsilon E_\varphi + \frac{\partial H_z}{\partial \rho}
 \end{aligned} \tag{95}$$

In addition we have the following equations for the longitudinal field components

$$\frac{\partial}{\partial \rho} (\rho E_\varphi) - \frac{\partial E_\rho}{\partial \varphi} = -j\omega\mu\rho H_z, \quad \frac{\partial}{\partial \varphi} (\rho H_\varphi) - \frac{\partial H_\rho}{\partial \varphi} = j\omega\epsilon\rho E_z \tag{96}$$

In view of (91), (95) becomes

$$\begin{aligned}
 \frac{\partial \hat{E}_\rho}{\partial z} &= -j\omega\mu \hat{H}_\varphi + \frac{\partial \hat{E}_z}{\partial \rho} \\
 \frac{\partial \hat{H}_\varphi}{\partial z} &= -j\omega\epsilon \hat{E}_\rho - \rho^{-1} \hat{H}_z \\
 \frac{\partial \hat{E}_\varphi}{\partial z} &= j\omega\mu \hat{H}_\rho + \rho^{-1} \hat{E}_z \\
 \frac{\partial \hat{H}_\rho}{\partial z} &= j\omega\epsilon \hat{E}_\varphi + \frac{\partial \hat{H}_z}{\partial \rho}
 \end{aligned} \tag{97}$$

while from (92) and (96) we obtain

$$\begin{aligned} \hat{H}_z &= V(z)(j\omega\mu N)^{-1}\chi J_1(\chi\rho) \\ \hat{E}_z &= -\bar{I}(z)(j\omega\epsilon\bar{N})^{-1}\bar{\chi}J_1(\bar{\chi}\rho) \end{aligned} \tag{98}$$

The expression for \hat{E}_z , even when completed by inclusion of the higher order radial modes, is valid only in the interior ($\rho < a$) of the junction. On the boundary we have

$$\hat{E}_z(a, z) = -\hat{E}_\rho(a, z) \tan \vartheta(z) \tag{99}$$

To obtain the telegraphist's equations we multiply the first column of (97) by

$$N^{-1}(\chi\rho)^{-1}J_1(\chi\rho)\rho \, d\rho$$

and

$$N^{-1}J_1(\chi\rho)\rho \, d\rho$$

respectively, add and integrate from $\rho = 0$ to $\rho = a$. The second column is similarly treated. The following are auxiliary calculations. In view of (92)

$$\int_0^a [\hat{H}_\rho N^{-1}(\chi\rho)^{-1}J_1(\chi\rho) + \hat{H}_\rho N^{-1}J_1'(\chi\rho)]\rho \, d\rho = -I(z) \tag{100}$$

The terms involving $\bar{I}(z)$ have disappeared after integration. To obtain

$$\int_0^a \frac{\partial \hat{E}_z}{\partial \rho} N^{-1}(\chi\rho)^{-1}J_1(\chi\rho)\rho \, d\rho + \int_0^a \hat{E}_z N^{-1}J_1'(\chi\rho) \, d\rho \tag{101}$$

we integrate the first term by parts

$$\hat{E}_z N^{-1}\chi^{-1}J_1(\chi\rho) \Big|_0^a - \int_0^a \hat{E}_z N^{-1}J_1'(\chi\rho) \, d\rho \tag{102}$$

The last term of this expression cancels the last term in (101); thus the total is

$$\begin{aligned} \hat{E}_z(a, z)\chi^{-1}N^{-1}J_1(\chi a) &= -\hat{E}_\rho(a, z) \tan \vartheta(z)\chi^{-1}N^{-1}J_1(\chi a) \\ &= (\chi N)^{-2}a^{-1}[J_1(\chi a)]^2 \tan \vartheta V(z) \\ &\quad - (\chi N\bar{N})^{-1}J_1(\chi a)J_1'(\bar{\chi} a) \tan \vartheta \bar{V}(z) \end{aligned} \tag{103}$$

At this point let us note that if we had decided to neglect the TM_{11} mode at the beginning, we would have set $\hat{E}_z = 0$ in equations (98). But in obtaining the telegraphist's equations from (97) it would still have been necessary to retain \hat{E}_z until after the integration has been per-

formed and the boundary condition utilized. To obtain

$$\int_0^a \left[-\rho^{-1} \hat{H}_z N^{-1}(\chi\rho)^{-1} J_1(\chi\rho) - \frac{\partial \hat{H}_z}{\partial \rho} N^{-1} J_1'(\chi\rho) \right] \rho d\rho \quad (104)$$

we also integrate by parts. This time expression (104) is found to equal

$$-\int_0^a \hat{H}_z N^{-1} \chi \rho J_1(\chi\rho) d\rho = -\frac{\chi^2}{j\omega\mu} V(z) \quad (105)$$

In the calculation of

$$\int_0^a \left[\frac{\partial \hat{E}_\rho}{\partial z} N^{-1}(\chi\rho)^{-1} J_1(\chi\rho) + \frac{\partial \hat{E}_\rho}{\partial z} N^{-1} J_1(\chi\rho) \right] \rho d\rho \quad (106)$$

and a similar integral involving \hat{H}_φ and \hat{H}_ρ we must remember that a , χ , and N are functions of z . Thus, this integral will be equal to

$$\begin{aligned} \frac{dV}{dz} + V(z) \int_0^a \left((\chi N\rho)^{-1} J_1(\chi\rho) \frac{\partial}{\partial z} [(\chi N\rho)^{-1} J_1(\chi\rho)] \right. \\ \left. + N^{-1} J_1'(\chi\rho) \frac{\partial}{\partial z} [N^{-1} J_1'(\chi\rho)] \right) \rho d\rho \\ + \bar{V}(z) \int_0^a \left((\chi N\rho)^{-1} J_1(\chi\rho) \frac{\partial}{\partial z} [\bar{N}^{-1} J_1'(\bar{\chi}\rho)] \right. \\ \left. + N^{-1} J_1'(\chi\rho) \frac{\partial}{\partial z} [(\bar{\chi} \bar{N}\rho)^{-1} J_1(\bar{\chi}\rho)] \right) \rho d\rho \end{aligned} \quad (107)$$

At this point we should point out another reason why we temporarily retained $\bar{V}(z)$. Each equation in a complete set of telegraphist's equations contains only one derivative of either a voltage function or a current function. To derive such a set of equations we must perform a weighted integration of Maxwell's equations with appropriate weighting factors as in (106). When $\bar{V}(z)$ is retained and wrong weighting factors are used, the derivative of $\bar{V}(z)$ with respect to z will not be eliminated and, hence, we shall be warned of our error. But when we neglect $\bar{V}(z)$ *ab initio*, we lose this self-checking feature. However, after we acquire some experience with this technique, we should not need the self-checking inherent in the retention of other modes.

The final equations for the dominant mode in a wave-guide-to-horn junction are

$$\frac{dV}{dz} = -ZI - {}^v TV, \quad \frac{dI}{dz} = -YV - {}^I TI \quad (108)$$

where

$$\begin{aligned} Z &= j\omega\mu, & Y &= j\omega\epsilon + \frac{(1.841)^2}{j\omega\mu[a(z)]^2} \\ {}^i T &= T, & {}^v T &= T + \frac{[J_1(\chi a)]^2 \tan \vartheta(z)}{\chi^2 N^2 a} \\ & & &= T + 0.837 a^{-1} \tan \vartheta(z), \end{aligned} \quad (109)$$

with T given by the integral associated with $V(z)$ in (107).

16. EFFECT OF COUPLING ON DEGENERATE OR NEARLY DEGENERATE MODES

Degenerate modes are the modes which have the same velocity of propagation when the coupling is absent. With such modes the coupling may be very important even when its magnitude is small. The reason is: the transfer of wave motion from one such mode to the other will be cumulative in the direction of propagation. This effect is illustrated by directional couplers or by beats in two coupled pendulums having the same resonant frequencies. In such cases the resistance of the waveguide wall should not be neglected for it may have an important effect aside from introducing attenuation. Thus, no matter how small is the coupling, the degenerate modes should be considered as a group even though their coupling to other modes may be neglected.

The same is true of nearly degenerate modes as in the case of waves over a plane impedance sheet at large distances from the source, such as the current element in Fig. 8.

17. COAXIAL CONDUCTORS-CIRCULARLY SYMMETRIC MODES

Heretofore, we have considered waves in waveguides completely shielded from the external space. A complete shielding implies a coating of that surface of a waveguide which is exposed to the external space with a substance which is either a perfect electric conductor or a perfect magnetic conductor. In practice such a perfect shielding is impossible. The foregoing equations are thus approximate, even though the effect of approximations on waves in the guide may be negligible for all practical purposes. On the other hand, the effect of imperfect shielding on the "cross-talk" or interference between two waveguides may be im-



Fig. 8 — A vertical current element above an impedance sheet.

portant, especially at relatively low frequencies, even though the magnitude of cross-talk is small. The most practical way to calculate this cross-talk between two parallel waveguides, let us say, is to solve the above approximate telegraphist's equations for one waveguide. Then, we can obtain the tangential electric intensity on the outer surface of this waveguide from that on the inner surface. This electric intensity will be impressed on the "two-wire line" formed by the two waveguides. Resulting currents can be calculated, and from them one can obtain the tangential electric intensity on the inner surface of the second waveguide. Finally, we can obtain the waves in the second waveguide which are stirred up by the tangential electric intensity. This method is illustrated elsewhere.¹⁴

The same method can be used for a single waveguide in empty space — an impractical situation — if we wish to calculate the first approximation to the feeble external field. The rest of this section is of theoretical interest only. Our object is to show that it is possible to obtain a set of telegraphist's equations for a waveguide which includes external waves as well as internal.

As a concrete example we shall take a pair of coaxial cylinders and consider circularly symmetric modes. First, we shall derive the equations for the internal waves only — as we did in the preceding sections — and then point out the modifications which must be introduced in order to include the external waves. As usual we start with Maxwell's equations

$$\begin{aligned} \frac{\partial E_\rho}{\partial z} &= -j\omega\mu H_\varphi + \frac{\partial E_z}{\partial \rho}, & \frac{\partial H_\varphi}{\partial z} &= -(g + j\omega\epsilon)E_\rho \\ E_z &= \frac{1}{(g + j\omega\epsilon)\rho} \frac{\partial(\rho H_\varphi)}{\partial \rho} \end{aligned} \quad (110)$$

and the boundary conditions

$$E_z(a, z) = Z_1 H_\varphi(a, z), \quad E_z(b, z) = -Z_2 H_\varphi(b, z) \quad (111)$$

It is the boundary conditions that we shall have to modify when we wish to include the external modes. The rest of the derivation follows along the lines already discussed. We have the expansions for the transverse field components in terms of modes appropriate to perfectly conducting coaxial cylinders

$$\begin{aligned} E_\rho &= \frac{V_0(z)}{\rho \log(b/a)} + \sum N_m^{-1} V_m(z) R_m'(\rho) \\ H_\varphi &= \frac{I_0(z)}{2\pi\rho} + \sum N_m^{-1} I_m(z) R_m'(\rho) \end{aligned} \quad (112)$$

The radial functions are defined by

$$\rho \frac{d^2 R_m}{d\rho^2} + \frac{dR_m}{d\rho} + \chi_m^2 \rho R_m = 0, \quad R_m(a) = R_m(b) = 0 \quad (113)$$

Hence,

$$R_m(\rho) = J_0(\chi_m \rho) N_0(\chi_m b) - N_0(\chi_m \rho) J_0(\chi_m b) \quad (114)$$

where χ_m is a root of

$$J_0(\chi_m a) N_0(\chi_m b) - N_0(\chi_m a) J_0(\chi_m b) = 0 \quad (115)$$

The normalizing factors are obtained from

$$N_m^2 = 2\pi \int_a^b [R_m'(\rho)]^2 \rho d\rho = 2\pi \chi_m^2 \int_a^b [R_m(\rho)]^2 \rho d\rho \quad (116)$$

The longitudinal electric intensity may be obtained (in the present instance) from the third equation of the set (110) and from (112),

$$E_z = -\sum \frac{\chi_m^2}{(g + j\omega\epsilon) N_m} I_m(z) R_m(\rho), \quad 0 \leq \rho < a \quad (117)$$

However, we should remind the reader that the telegraphist's equations may be obtained without this equation since we can eliminate E_z from (110) before embarking on their derivation.

Multiplying the first equation of the set (110) by $N_p^{-1} R_p'(\rho) \rho d\rho d\varphi$ and integrating, we find

$$\begin{aligned} \int_0^{2\pi} \int_a^b \frac{\partial E_z}{\partial \rho} N_p^{-1} R_p'(\rho) \rho d\rho d\varphi &= 2\pi E_z(\rho, z) N_p^{-1} R_p'(\rho) \rho \Big|_a^b \\ &\quad - \int_0^{2\pi} \int_a^b N_p^{-1} E_z \frac{d}{d\rho} [\rho R_p'(\rho)] d\rho d\varphi \\ &= 2\pi E_z(b, z) N_p^{-1} b R_p'(b) - 2\pi E_z(a, z) N_p^{-1} a R_p'(a) \\ &\quad + \chi_p^2 N_p^{-1} \int_0^{2\pi} \int_a^b E_z R_p(\rho) \rho d\rho d\varphi \\ &= 2\pi E_z(b, z) N_p^{-1} b R_p'(b) - 2\pi E_z(a, z) N_p^{-1} a R_p'(a) - \frac{\chi_p^2}{g + j\omega\epsilon} I_p(z) \end{aligned} \quad (118)$$

Using the boundary conditions (111) and treating the second equation of the set (110) in the already familiar manner we obtain the distributed

parameters for the internal modes

$$\begin{aligned}
 Z_{pp} &= j\omega\mu + \frac{\chi_p^2}{g + j\omega\epsilon} + 2\pi N_p^{-2}(Z_1 a [R_p'(a)]^2 + Z_2 b [R_p'(b)]^2), \quad p \neq 0 \\
 Z_{p0} &= N_p^{-1}[Z_1 R_p'(z) + Z_2 R_p'(b)], \quad p \neq 0 \\
 Z_{00} &= \frac{j\omega\mu}{2\pi} \log(b/a) + \frac{Z_1}{2\pi a} + \frac{Z_2}{2\pi b}, \quad Y_{00} = \frac{2\pi(g + j\omega\epsilon)}{\log(b/a)} \\
 Y_{pm} &= g + j\omega\epsilon.
 \end{aligned} \tag{119}$$

To include the external modes we shall pick a center for their origin. For a semi-infinite coaxial pair this center may be chosen on the axis near the end of the pair. For coaxial cylinders extending to infinity in both directions the center may be chosen arbitrarily on the axis but preferably near the source of internal waves. The external modes are then defined as in Sections 12 and 13 and the coupling between the external and internal modes is given by

$$\begin{aligned}
 E_z^i &= -(\eta_c \coth \sigma_c h) H_\varphi^i + (\eta_c \operatorname{csch} \sigma_c h) H_\varphi^o \\
 E_z^o &= -(\eta_c \operatorname{csch} \sigma_c h) H_\varphi^i + (\eta_c \coth \sigma_c h) H_\varphi^o
 \end{aligned} \tag{120}$$

where E_z^i and H_φ^i are taken at the inner surface of the outer cylinder and E_z^o and H_φ^o at the outer surface. In these equations η_c and σ_c are respectively the intrinsic impedance and propagation constant of the substance from which the outer cylinder is made. The thickness h of this outer cylinder is assumed to be small compared with its radius. Otherwise, the self and mutual impedances in (120) should be expressed in terms of the modified Bessel functions. Another assumption is that σ_c is very large compared with the propagation constants of various modes under consideration. For metal walls this assumption is highly satisfactory for all modes except those of exceedingly high order. In (118) we must substitute E_z^i for $E_z(b, z)$. In a corresponding equation for external mode we should use E_z^o as given by (120).

18. VANE ATTENUATORS

Our last example will be the "vane attenuator" in a rectangular waveguide, Fig. 9. The dotted line passing through AB represents a thin resistive sheet, so thin that the vertical current under the influence of a vertical field is distributed uniformly through the thickness of the sheet. Hence, the vertical electric intensity is continuous across the sheet. It is

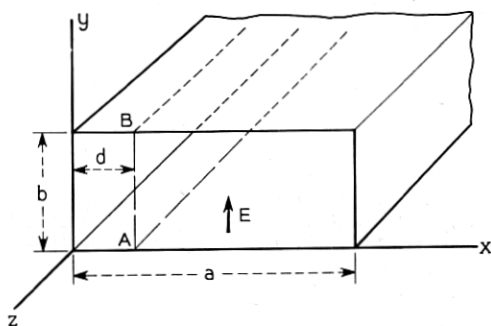

Fig. 9 — A rectangular waveguide with a thin resistive sheet.

not difficult to solve an appropriate boundary value problem. If we assume for simplicity that the guide walls are perfectly conducting and confine our attention to waves whose intensities are independent of the y -coordinate, Maxwell's equations separate in two sets, one involving E_y , H_x , and H_z and the other H_y , E_x , and E_z . We shall consider the first set [see (63)]. The resistive sheet implies a discontinuity in H_z ,

$$H_z(d - 0, z) - H_z(d + 0, z) = YE_y(d, z) \quad (121)$$

where Y is the admittance of a unit area of the sheet. This will include not only the conductance of a thin metallic film but also the capacitance of a thin plastic film on which the metal may be deposited. The usual solution of the boundary problem will be obtained by assuming two separate fields, one for the region to the left of the sheet and one for the region to the right of it. Taking into consideration the continuity of E_y and the discontinuity in H_z , we shall find a transcendental equation for the propagation constants of the various modes appropriate to the waveguide with a thin resistive sheet.

Here, however, we shall express the field in the waveguide with the sheet in terms of modes appropriate to the same waveguide without the sheet. Thus we assume expansions (64) for E_y and H_x and (65) for H_z . Since E_y and H_x are continuous functions, their sine series are uniformly convergent as well as differentiable. On the other hand, H_z is discontinuous and neither differentiable nor uniformly convergent. This non-differentiability affects the calculation of the following integral

$$P_m = \int_0^b \int_0^a \frac{\partial H_z}{\partial x} N_m^{-1} \sin \frac{m\pi x}{a} dx dy \quad (122)$$

needed in the conversion of Maxwell's equations into telegraphist's

equations. First we have to split it into two integrals

$$P_m = \int_0^b \int_0^{d-0} + \int_0^b \int_{d+0}^a \quad (123)$$

Then we have to integrate it by parts,

$$P_m = bH_z N_m^{-1} \sin \frac{m\pi x}{a} \Big|_0^{d-0} + bH_z N_m^{-1} \sin \frac{m\pi x}{a} \Big|_{d+0}^a - \int_0^b \int_0^a \frac{m\pi}{a} H_z \cos \frac{m\pi x}{a} dx dy \quad (124)$$

And finally we have to substitute H_z from the third equation of the set (63) into the integrand of (124) and integrate by parts once more before substituting the series for E_y from (64). In this way we find

$$P_m = bN_m^{-1} [H_z(d-0, z) - H_z(d+0, z)] \sin \frac{m\pi d}{a} + \frac{m^2 \pi^2}{j\omega\mu a^2} V_m(z) \quad (125)$$

The bracketed term may be expressed in terms of V_n 's if we use (64) and (121). In this way, we obtain the following telegraphist's equations

$$\begin{aligned} \frac{dV_m}{dz} &= -j\omega\mu I_m \\ \frac{dI_m}{dz} &= -\left(g + j\omega\epsilon + \frac{m^2 \pi^2}{j\omega\mu a^2} + \frac{2Y}{a} \sin^2 \frac{m\pi d}{a} \right) V_m \\ &\quad - \sum'_n \frac{2Y}{a} \sin \frac{m\pi d}{a} \sin \frac{n\pi d}{a} V_n \end{aligned} \quad (126)$$

where the prime after the summation signs signifies the omission of the term corresponding to $n = m$.

19. ARBITRARINESS OF MODAL TRANSVERSE FIELD PATTERNS

In almost all examples considered by us the variations of transverse field components in transverse planes were expressed in terms of functions associated with orthogonal modes in waveguides of uniform cross-section and with perfectly conducting walls. An exception was made in Section 10 where we used curvilinear coordinates. The guiding principle in selecting the basic set of transverse field patterns for general field representation should be in most cases, but not in all cases, the minimization of coupling coefficients. That there are exceptions was made clear in

connection with the junction between two waveguides, one with perfectly conducting and the other imperfectly conducting walls, Fig. 2 (see remarks toward the end of Section 3). Aside from convenience the choice of transverse modal patterns is rather arbitrary. A set must be complete, that is, adequate for representing any field which can exist inside the guide. It should be an orthogonal set; this will enable us to obtain a set of telegraphist's equations in which each equation contains only one derivative with respect to the direction of propagation. But, as we have already seen, the sets of terms representing the individual "modes" do not have to satisfy either Maxwell's equations or the boundary conditions. The situation is similar to that which confronts us when we choose a set of meshes in a network in order to write Kirchhoff's equations in terms of mesh currents.

In the case of circular waveguides, for instance, we can express E_ρ and H_ϕ in terms of the "sawtooth" functions in which case E_z will be expressed in terms of "square sine" functions. It is not a convenient set; but, certainly, it is a permissible set.

20. CONCLUDING REMARKS

In the preceding sections we have illustrated the technique of conversion of Maxwell's equations into generalized telegraphist's equations by several typical examples. In many instances this technique is a practical method for solving field problems. This method may be valuable even when the more conventional methods can be used. Consider a slightly deformed rectangular waveguide in which two faces are arcs of coaxial cylinders and the other two faces are radial planes, Fig. 10. If we use cylindrical coordinates, we can separate the variables and obtain a set of orthogonal modes in which fields are expressed in terms of Bessel functions. As the curvature decreases these modes become more and more like the corresponding modes in a strictly rectangular waveguide. Nevertheless the mathematical machinery remains different. No matter how

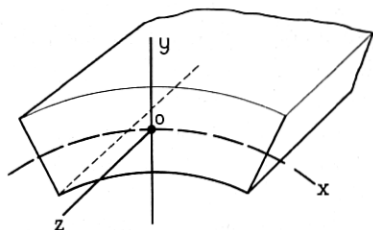

Fig. 10 — A deformed rectangular waveguide.

small is the curvature we still have to deal with Bessel functions rather than with sines and cosines. We can and will, of course, replace Bessel functions by their asymptotic expansions. This will simplify mathematics. But we still would be left with a "discontinuity in thinking" about the zero and non-zero curvature cases. At any rate it seems that we can gain something in understanding the effect of the gradual deformation on the field, particularly if this deformation is varying along the guide, by formulating the problem in terms of "deformed cartesian" coordinates. Then the effect of deformation will be thought of as coupling between various modes in a strictly rectangular waveguide. The coupling coefficients can be evaluated and numerical results thus obtained for more general conditions than is possible by the conventional method.

In other cases, numerical calculations, although possible in theory, would perhaps be prohibitive in practice. Even then this technique may contribute toward the qualitative understanding of physical phenomena. Consider two wires diverging from the terminals A, B of a generator, Fig. 11. Let us imagine a family of spheres concentric with the midpoint of the segment AB. Let us consider the sections of wires intercepted by a typical sphere as sections of two cones with their apices at the center of the spheres. For such cones we can obtain a set of orthogonal modes. The transverse field distributions associated with these modes we now take for representing the field distribution in the actual case, just as we did in previous examples. One of the infinite system of such modes will be the principal mode which at sufficiently large distances from A, B will be the usual "transmission line" mode for two parallel wires (that is, when the wires actually do become parallel). It would not be difficult as a matter of fact to obtain telegraphist's equations for this mode together with coupling coefficients to the higher order modes. For perfectly conducting wires these coupling coefficients become progressively smaller

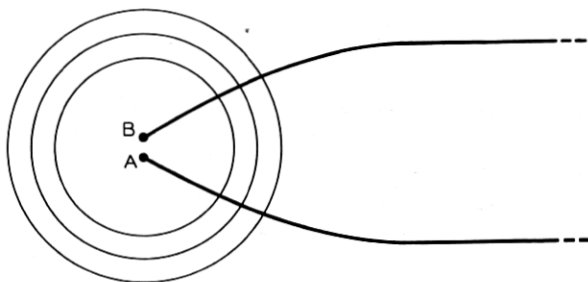

Fig. 11 — Wires diverging from the terminals of a generator.

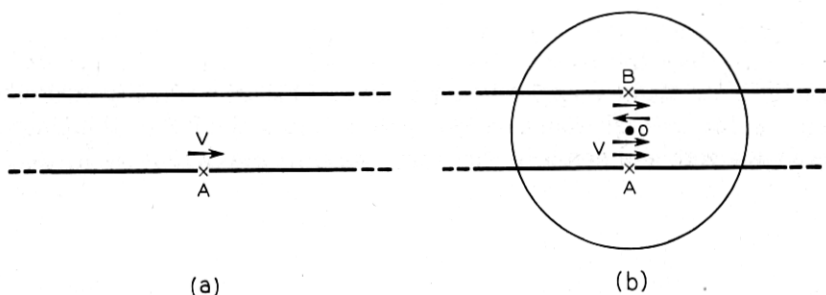

Fig. 12 — Parallel wires with a generator at A.

as the distance from the generator increases. Thus the higher order modes will be generated largely in the vicinity of the generator if we define the "vicinity" as the interior of a sphere whose radius is a reasonably large multiple of the final distance between the wires. These are the modes which will carry off to infinity what we usually call the "radiated energy." There will be very little radiation if the distance between the wires never exceeds a small fraction of the quarter-wavelength. This is because the higher order modes are substantially non-propagating at distances close to the center of their origin.

For thin wires the calculation of transverse patterns needed for telegraphist's equations requires the solution of a transcendental equation.¹⁵ To use this equation in the present case we should replace the oval traces of the wires on a typical "wavefront" sphere by equivalent circles, that is, circles giving the same shunt capacitance in the principal mode. A more accurate analysis would be possible but hardly worth the effort.

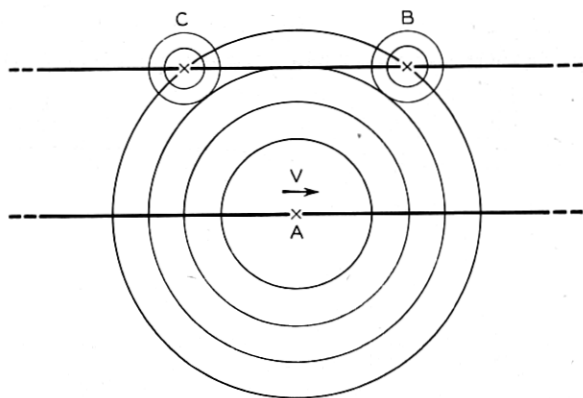

Fig. 13 — Parallel wires and a succession of primary and secondary waves.

An analysis of waves on two parallel wires, such as Mie's,² is not realistic since he assumed that his generator is at infinity. Sometimes such an assumption is not objectionable; but at other times one is better off without it. If two parallel wires are infinite in both directions and a generator is connected to one wire, Fig. 12(a), and if the distance between the wires is small, one can conveniently replace the impressed voltage by the sum of push-push and push-pull voltages, Fig. 12(b), to take advantage of the symmetry. Then outside some sphere concentric with the mid-point O , we have four wires "diverging" from O and the analysis may proceed along the lines suggested for two wires. If, however, the distance between the wires is large, we shall find it more expedient to consider waves on a single wire generated at point A , Fig. 13, which in their turn generate waves on the second wire at points where the spherical wavefronts intersect it. Those waves impinge on the first wire and generate tertiary waves.

Many other examples will occur to the reader in which the telegraphist's equations will be useful to a greater or lesser extent.

REFERENCES

1. Sir William Thomson (Lord Kelvin), *Mathematical and Physical Papers*, **2**, p. 79, Cambridge University Press (1884).
2. G. Mie, *Electrische Wellen an Zwei Parallelen Drahten*, *Ann. der Phys. Ser. 4*, **2**, pp. 201-249, 1900.
3. John R. Carson, *Electromagnetic Theory and the Foundations of Electric Circuit Theory*, *B.S.T.J.* **6**, pp. 1-17, Jan., 1927.
4. S. A. Schelkunoff, *Electromagnetic Theory of Coaxial Transmission Lines and Cylindrical Shields*, *B.S.T.J.*, Oct., 1934.
5. S. A. Schelkunoff, *Electromagnetic Waves*, p. 282, D. Van Nostrand Co., 1943.
6. S. A. Schelkunoff, *Transmission Theory of Plane Electromagnetic Waves*, *Proc. I.R.E.*, **25**, pp. 1457-1492, Nov., 1937.
7. S. A. Schelkunoff, *Generalized Telegraphist's Equations for Waveguides*, *B.S.T.J.*, **31**, pp. 784-801, July, 1952.
8. S. P. Morgan, Jr., *Mode Conversion Losses in Transmission of Circular Electric Waves through Slightly Non-cylindrical Guides*, *J. Appl. Phys.*, **21**, pp. 329-338, April, 1950.
9. S. A. Schelkunoff, *Electromagnetic Waves*, D. Van Nostrand Co., 1943, pp. 485-488.
10. W. J. Albersheim, *Propagation of TE_{01} Waves in Curved Waveguides*, *B.S.T.J.*, pp. 1-32, Jan., 1949.
11. Reference 5, pp. 92-94.
12. E. T. Whittaker and G. N. Watson, *A Course of Modern Analysis*, Cambridge University Press, pp. 78-80, 1927.
13. S. A. Schelkunoff, *Applied Mathematics for Engineers and Scientists*, D. Van Nostrand Co., pp. 154-155; 1948.
14. S. A. Schelkunoff and T. M. Odarenko, *Crosstalk Between Coaxial Transmission Lines*, *B.S.T.J.*, **16**, pp. 144-164, April, 1937.
15. S. A. Schelkunoff, *Advanced Antenna Theory*, John Wiley & Sons, 1952, equation (312), p. 98.

