

THE BELL SYSTEM TECHNICAL JOURNAL

VOLUME XXXIV

JULY 1955

NUMBER 4

Copyright, 1955, American Telephone and Telegraph Company

A New Local Video Transmission System

By STEPHEN DOBA, JR., and A. ROBERT KOLDING

(Manuscript received March 4, 1955)

The design features of the new A2A television transmission system are described. Under the diverse conditions of circuit length and repeater spacing in short-haul television connecting circuits, considerable flexibility is required. Several examples are given of the use of the A2A system to illustrate this flexibility.

INTRODUCTION

The A2A system is a new broadband wire transmission system for providing television connecting circuits over short distances. The system provides video transmission for frequencies up to 4.5 mc over balanced pairs designed for such use. Its design is predicated on meeting high quality performance objectives for a 4,000 mile network, which may comprise a number of A2A circuits along with intercity television systems of other types.

Television connecting circuits are used for a variety of purposes in network operations. Some examples of these uses are illustrated by the diagram of Fig. 1. Large broadcasters usually have their studios, master control, and broadcast transmitter distributed among several buildings in various locations in a city or metropolitan area. The A2A system furnishes broadband tielines to interconnect these facilities. Two-way con-

nections between the master control location and the studio are often required for programming purposes. For example, filmed material from the master control location may be sent to the studio, there to be combined with the live program and returned to the master control over a second circuit. For local broadcast transmission a third circuit to the radio transmitter is required.

For network operation, connecting circuits are required between the master control and the central switching point where connections to the intercity coaxial or microwave radio systems are made. From the Television Operating Center, as this switching point is called, wire circuits are frequently used to send to or receive from a microwave terminal which may be located outside the city. It is interesting to note that three local circuits may appear in tandem when the station is receiving from the network, and either three or four may occur in tandem when the station is feeding the network with material from a remote studio.

Local networks for theater television and for other closed circuit arrangements such as medical demonstrations are other uses for local wire systems.

The first systems used for network operation were the L1 coaxial system¹ for intercity circuits and the A2 video transmission system² for local

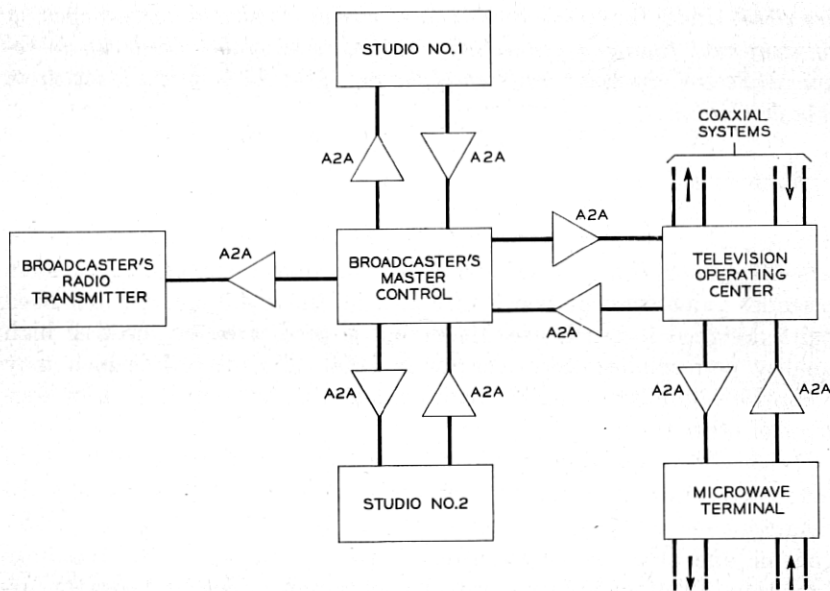

Fig. 1 — Typical A2A uses.

distribution. Subsequent developments produced two improved long distance broadband systems; the TD-2 microwave system³ and the L3 coaxial system.⁴ The A2A system provides the complementary improvement needed for the short-haul connections and should result in reduced maintenance effort and a minimum of special engineering to provide acceptable transmission quality.

The wide range of circuit lengths over which the A2A must operate and the erratic pattern of terminal and repeater locations constitute the outstanding requirements dictating the system design. The circuit lengths range from a fraction of a mile to approximately 10 miles; with the median length being about 1.5 miles. These requirements have been met by providing a series of amplifier and equalizer components which may be assembled in a large variety of combinations. By comparison, in long distance systems such as the L3 coaxial system, the repeaters have almost constant spacing, with the result that all repeaters have the same gain and cable equalization.

Many local circuits are ordered by the television broadcaster for short time use, such as program pickups of sporting events. Since these circuits are frequently requested on short notice, there is usually little time for circuit engineering. For these purposes portable equipment units which are readily convertible from one circuit length to another have been made available.

Another major factor affecting system design lies in the varied and, in general, non-predictable usage of the local links. Frequently the makeup of a complex transmission network varies from hour to hour as demand dictates, and it is not possible to line up or equalize the network on an overall basis. Hence, each link must be capable of a transmission quality such that when all the necessary links are connected in tandem the signal will not be degraded.

The A2A system has been designed to use the extensive existing video cable plant. This plant consists of 16-gauge polyethylene insulated pairs⁵ incorporated in standard lead and composite sheathed cables installed since 1947. Ordinary telephone cable paper pairs, which have been used to a limited extent with the existing A2 system, are not suitable for use with the A2A system. In the earliest commercial form of the cable the individual video pairs were covered with two copper wrappings wound spirally in opposite directions. A pair having this construction is referred to as a 16 PSVS video pair. Early in 1950 the design was changed to a form with a longitudinal inner wrapping with the outer tape applied spirally as before. This design is known as 16 PSVL video pair and gives lower crosstalk and a small reduction in attenuation.

In 1953, production began on a new design in which the polyethylene string and strip insulation of the earlier types was supplanted by individual insulation of the conductors with expanded polyethylene together with expanded polyethylene fillers. This type, referred to as 16 PEVL video pair, is a cable whose impedance is held to closer tolerances and has reduced internal echoes. Both 16 PSVL and 16 PEVL are currently in production, and all three types of cable may be referred to collectively as 16 PSV video pair. The A2A system may be used on any of the types. Fig. 2 shows the construction of each of these cables.

The requirement to equalize a wide range of circuit lengths and repeater spacings has a further effect on system design. As is well known, lack of proper terminations produce interaction effects (multiple echoes) which are not simple functions of the cable length. Adequate equalization is exceedingly difficult under these conditions. This difficulty is avoided by terminating the cable at each end in networks which match the image impedance of the cable. This results in an insertion loss characteristic which is the attenuation characteristic of the cable with negligible terminal or reflection effects. The loss of the 16 PSVL or 16 PEVL pairs in db per mile is shown on Fig. 3.

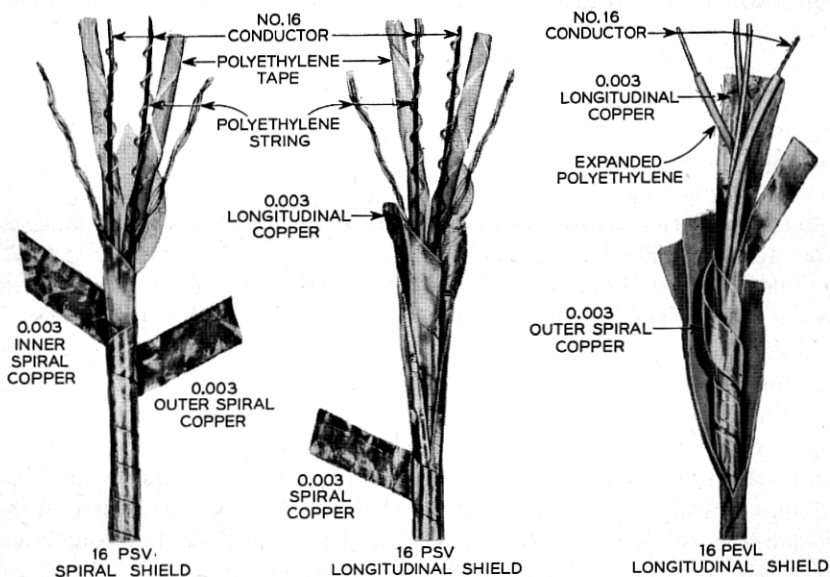

Fig. 2 — Polyethylene insulated cables used in the A2A system.

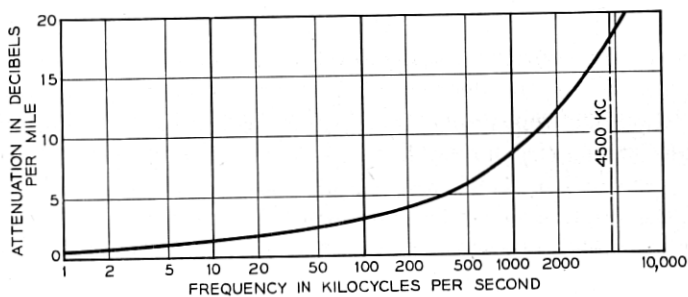

Fig. 3 — Attenuation of PSVL or PEVL cable.

DESCRIPTION OF SYSTEM

In this section the A2A system is described in terms of its application to several typical circuits. A subsequent section describes the transmission performance of a representative circuit. This is followed by a section devoted to a detailed description of the separate components of the system, and the manner of physical arrangement of terminals and repeaters. Since the equalization design of the A2A system is the subject of a companion article⁶ the treatment here is limited to functional description of the several equalizers.

The wide range of circuit lengths used in local circuits is demonstrated by Fig. 4 which shows the distribution of circuit lengths in miles of A2

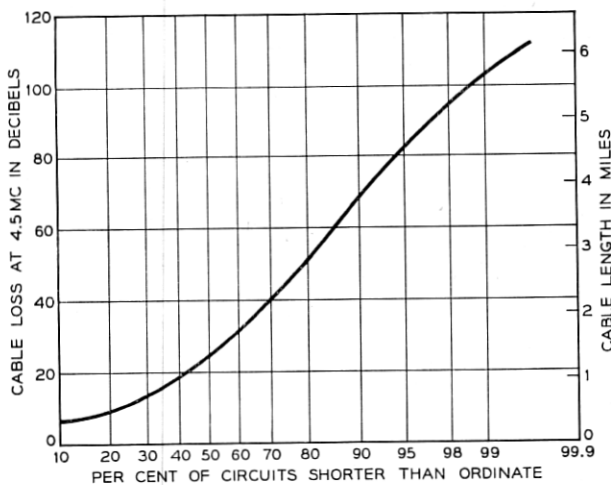

Fig. 4 — Distribution of A2 system circuit lengths in 1952.

circuit installations existing in 1952. Since the A2A is intended for use under similar conditions these data are a useful design guide. This wide range of circuit lengths requires both repeatered circuits and single section, non-repeatered circuits. The A2A solution to this problem is provided by a series of amplifiers, equalizers, and attenuators that can be interconnected in many ways to provide the needed flexibility. In general, the amplifiers have flat gain over the 0 to 4.5 mc band; however, two of the amplifier designs are provided with step-up networks which partially equalize for fixed lengths of cable. Fixed cable equalizers in sizes of 20, 15, 10, 7.5, 5, and 2.5 db are provided. In addition to the fixed equalizers two adjustable equalizers are available which have a total of nine variable equalization shapes.

Because the cable is terminated in essentially its image impedance, the low-frequency insertion loss of the cable is very low, approaching zero. The amplifier gains and equalizer components used are determined by the high-frequency loss of the cable which is proportional to cable length.

The provision of the necessary equalization and gain is achieved by connecting in tandem the proper combinations of amplifiers, equalizers, and attenuators in the proper associated combinations.

The system functions can best be described with reference to several typical circuit layouts. The first of these, shown on Fig. 5, is a 2.2-mile single-link circuit between two broadcaster's locations. The transmission equivalent of this circuit is unity. The normal input is one volt peak-to-peak of video signal. The example chosen is about half as long as the maximum non-repeatered length capability of the system.

The first unit of the transmitting terminal is an equalizer, which pre-equalizes for 15 db of the cable slope. The output amplifier has a voltage gain of 11 db and converts from 75-ohm unbalanced input to a balanced output to drive the video pair. The output impedance matches the cable impedance down to about 200 cps.

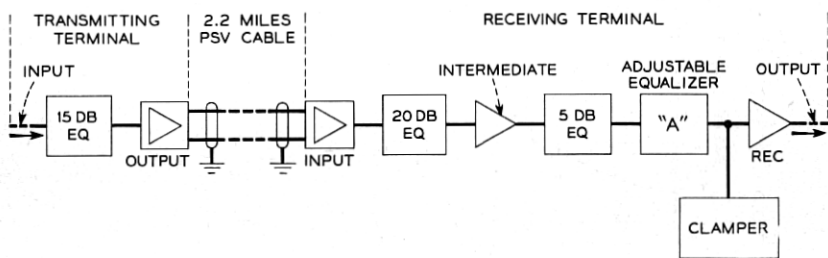

Fig. 5 — Block schematic of a typical single-link circuit.

With impedance matching terminations at both ends of the cable pair, the insertion loss equals the cable attenuation, which is essentially zero at dc, and for the example chosen is 41 db at 4.5 mc. Since the gain of the amplifiers is flat with frequency, the low-frequency line level is made low to prevent excessive modulation in the input amplifier of the receiving terminal. On the other hand the high-frequency sending level is made high to override the cable loss. In the arrangement shown on Fig. 5 the transmitting terminal has a voltage gain of 5 db at 4.5 mc, and due to the shaping of the cable equalizer has introduced a loss of 10 db at very low frequencies.

The input amplifier of the receiving terminal terminates the balanced cable, matching the impedance down to low-frequencies and provides 10 db of gain preceding the first equalizer.

Of the 44 db of slope in the assumed cable length, 15 db is pre-equalized in the transmitting terminal, and 26 db remains to be made up in the receiving terminal. A 20-db block of equalization is provided in the form of the 20-db cable equalizer and intermediate amplifier, whose 24-db flat gain equals the dc loss of the equalizer. The remaining 6-db slope is reduced to 1 db by a 5 db fixed equalizer. Using the fixed equalizers which are available in 2.5-db increments, the cable slope can be reduced to within ± 1.25 db. The remainder, which in the circuit chosen is 1 db, is equalized in the variable "A" equalizer, which provides equalization shape in very small adjustable steps over a range of ± 3 db at 4.5 mc. The meaning of ± 3 db is that at one extreme setting of the dial 3 db of cable slope is equalized; at the mid-position of the dial a flat loss shape is obtained, and at the other extreme of the dial, the loss shape simulates 3 db of cable.

The excess range of the variable equalizer over the ± 1.25 db needed to augment the 2.5 db fixed equalizer is used for periodic equalization adjustment for changes in loss due to change in cable temperature.

In addition to its function as a variable cable length equalizer, the "A" equalizer also provides four other equalization shapes to accommodate differences among the cable types used with this system. For circuit lengths up to about 3.5 miles these five variable shapes and the fixed equalizers suffice to meet transmission objectives.

The remaining components of the block schematic of Fig. 5 are a clamper and a receiving terminal amplifier. The clamper¹⁰ operates as a shunt device across the 75-ohm circuit reducing low-frequency noise and correcting for the signal waveform distortion due to the low frequency cut-off of the amplifiers.

The receiving terminal amplifier has an adjustable amount of flat gain

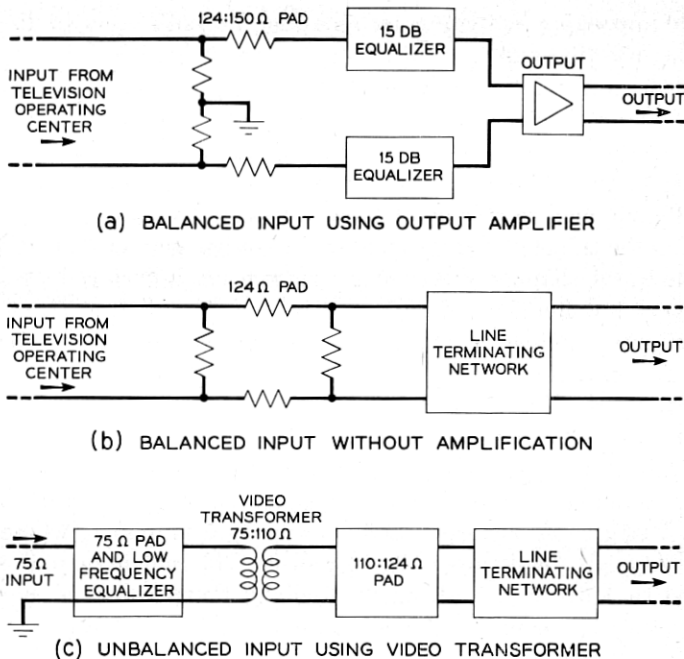

Fig. 6 — Other transmitting terminals. (a) Balanced input using output amplifier; (b) Balanced input without amplification; and (c) Unbalanced input using video transformer.

to make up for the loss of the fixed and variable equalizers following the intermediate amplifier. The gain adjustment is provided to compensate for the variation in flat loss of the "A" equalizer with dial setting, and also to set the end-to-end circuit equivalent.

The receiving terminal amplifier has alternate output arrangements: a balanced output at 124-ohm impedance for use in circuits terminating at television operating centers and a 75-ohm unbalanced output for circuits terminating at customers' locations.

In the example of Fig. 5 the equalization was the maximum for a receiving terminal with one intermediate amplifier. The changes to accommodate shorter circuits will next be described. The 5-db fixed equalization can be reduced in 2.5-db steps down to 0. Plug-in loss pads are then used to make up for the reduced equalizer loss so that the low-frequency gain remains fixed. For still shorter cable lengths the 20-db equalizer can be reduced to 15 db or 10 db, and again loss pads are added as required. Beyond this, the intermediate amplifier may be omitted. When this is done the maximum fixed equalizer range is the sum of the

15 db in the transmitting terminal and 5 db in the receiving terminal or 20 db. Adding the variable equalizer range gives a total of 23 db or about 1.3 miles, which is the median length of the present A2 system installations.

A further reduction in the equalization is obtained by reducing the 15-db fixed cable equalizer in the transmitting terminal to a smaller size or zero and adding loss pads to keep the low-frequency loss constant, as before.

Longer circuits than that of Fig. 5 may be used by adding a second intermediate amplifier and 20-db equalizer to the receiving terminal. The total of the fixed equalizers would then be 60 db, giving about 63 db or 3.5 miles when the range of the variable equalizer is included. This is the maximum single-link circuit length using the flat gain input and output amplifiers which is set by signal-to-noise requirements.

Provision for balanced input and output circuit arrangements have been made for the A2A circuits that originate or terminate in the television operating center. The receiving terminal amplifier has alternate output connections to provide either 124-ohm balanced output or 75-ohm unbalanced output. The output amplifier has a 150-ohm balanced-to-ground input impedance, which was chosen so that the 75-ohm unbalanced cable equalizers could be used in pairs to form a balanced equalizer, instead of duplicating the fixed equalizer designs in 124-ohm balanced form. An impedance transforming pad converts the 124-ohm input to 150 ohms. This arrangement is shown on Fig. 6(a).

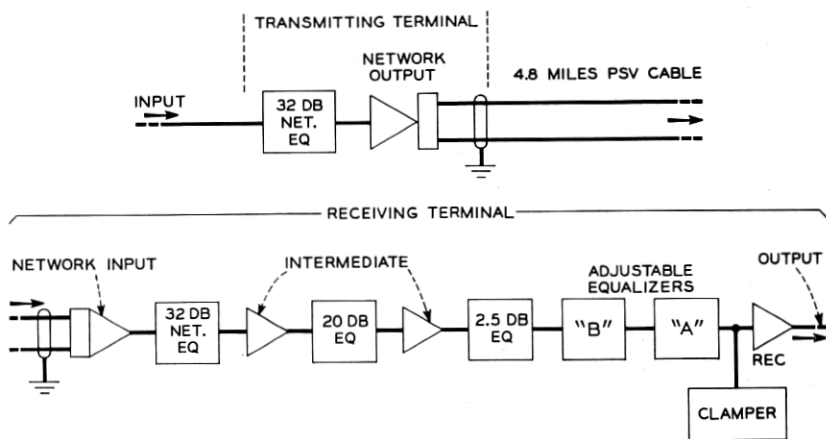

Fig. 7 — Maximum length single-link circuit.

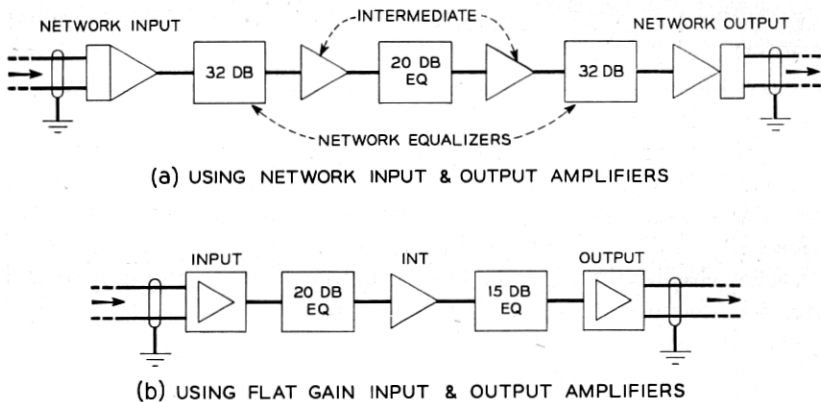

Fig. 8 — Typical repeater circuits. (a) Using network input and output amplifiers, and (b) Using flat gain input and output amplifier.

An additional balanced input transmitting terminal is shown on Fig. 6(b). The amplifier and fixed cable equalizers are omitted, so that the output level is flat. This arrangement may be used for short links.

A similar circuit for unbalanced inputs is shown on Fig. 6(c). The amplifier and fixed equalizers are omitted. A video transformer² converts the unbalanced input to balanced output to drive the cable. Low-frequency adjustable equalization is provided to compensate for the low-end cut-off characteristic of the transformer.

The use of the network output and input amplifiers permits the maximum single link span to be increased to 86.5 db of loss at 4.5 mc or 4.8 miles of cable. Such a circuit is illustrated in the block schematic of Fig. 7. The transmitting terminal uses an output amplifier in which the output tubes operate into a network embodying transformer action over the upper part of the 4.5-mc band. At low-frequencies the transformer is by-passed and the vacuum tubes operate into a 124-ohm resistive load. The transformer coupling increases the output level capability at high frequencies where it is needed to overcome the cable loss. The circuit of Fig. 7 thus delivers a greater high-frequency output to the cable than the flat-gain output amplifier of Fig. 5.

The gain step-up shape of the output network differs from the required shape for equalizing cable and requires a corrective equalizer to provide the equivalent of the fixed equalizer designs. This corrective function is combined with about 17 db of the fixed equalizer shape in the network equalizer to make a total of 32 db of cable equalization in this transmitting terminal, compared to a maximum of 15 db in the first case. The

amount of pre-equalization in this transmitting terminal cannot be reduced below the 32 db provided by the network equalizer and network amplifier.

The receiving terminal shown on Fig. 7 uses a network input amplifier which contains a step-up network similar to that in the network output amplifier. The impedance step-up in the upper part of the band provides a signal-to-noise improvement over the flat-gain input amplifier. The combination of both network input and output amplifiers increases the allowable circuit length or repeater spacing about 26.5 db at 4.5 mc.

The input network equalizer serves the same function as the output network equalizer and also provides a total equalization of 32 db, in combination with the input network amplifier.

The receiving terminal of Fig. 7 contains three sections. The first provides the network input amplifier, network equalizer and intermediate amplifier. It equalizes for 32 db of cable slope, with no option for lesser equalization. The second section providing a maximum of 20 db of equalization, contains a fixed equalizer and intermediate amplifier. As before, the equalization may be reduced below 20 db to 15, 10 db, or less; or the amplifier and equalizer may be omitted entirely if the cable loss slope permits.

The third part contains the small size fixed equalizer (2.5 db in the case shown on Fig. 7), variable equalizers, clamper and receiving terminal output amplifier. This group differs from the counterpart of Fig. 5 only in the addition of a second variable equalizer, the "B" unit.

The "B" equalizer⁶ contains four manually adjustable loss shapes located in frequency regions between the loss shapes of the "A" equalizer. For circuits shorter than about 3.5 miles, the "B" equalizer is usually not required.

The methods of circuit arrangement for other cable lengths are similar to those already described in connection with the circuit of Fig. 5. One limit is reached at 64 db which is the sum of the irreducible equalization associated with the network input and output amplifiers. A further reduction in slope equalization is available by replacing the network input amplifier and its 32 db of equalization with the flat gain input amplifier. The minimum slope would then be the 32 db of the network output amplifier and its accompanying network equalizer. The use of the flat gain amplifiers at both input and output as in Fig. 5 provides the means for handling circuits shorter than 32 db. However, the upper limit of length is then about 60 db.

The application of the A2A system to circuits longer than 4.5 miles requires one or more intermediate repeaters. In general the repeater

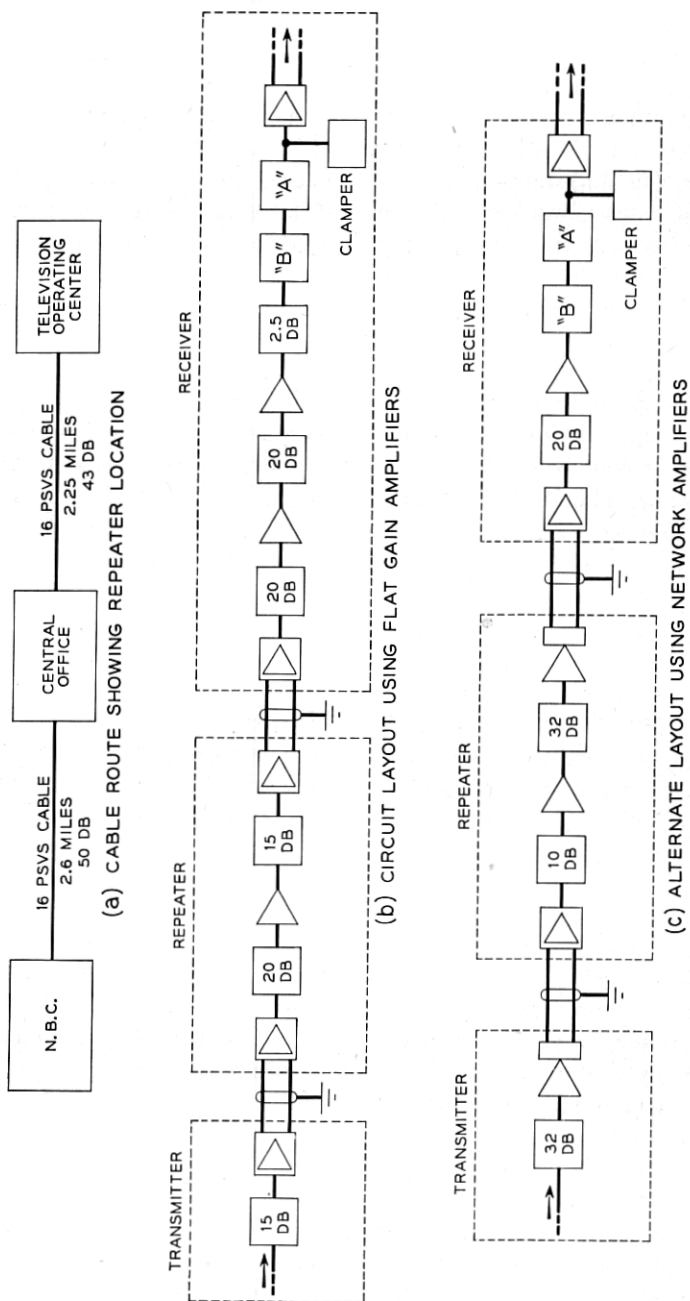

Fig. 9—Typical two-link circuit. (a) Cable route showing repeater locations; (b) Circuit layout using flat gain amplifiers; and (c) Alternate layout using network amplifiers.

spacing will be variable since it is desirable to place the repeaters in existing Telephone Company buildings. Two typical repeater arrangements are illustrated by the block schematics of Fig. 8. The repeaters use the same amplifier and fixed equalizer components as the transmitting and receiving terminals.

Fig. 8(a) shows a maximum equalization repeater using network amplifiers for both input and output. The input section provides 32 db, the intermediate section 20 db, and the output section 32 db, for a total of 84 db. Reduction of the equalization is accomplished in the same manner as in receiving terminals, the minimum here being 64 db of cable slope.

A repeater using flat gain input and output amplifiers and one intermediate amplifier is illustrated in Fig. 8(b). The arrangement shown provides 35 db of equalization. This can be reduced to 15 db by removing the intermediate amplifier and 20 db equalizer. Further reduction is handled by replacing the 15 db equalizer with smaller units.

The addition of a 20-db equalizer and intermediate amplifier to the circuit of Fig. 8(b) provides a means for extending the equalization to a maximum of 55 db for repeaters using flat gain input and output amplifiers.

The position of a repeater in an A2A circuit may be such that one line section is short and the other long due to the use of existing Telephone Company offices. For these cases repeaters with flat gain input amplifiers and network output amplifiers or vice versa are used. In all, 10 different amplifier arrangements for repeaters are available.

The A2A field trial installation in New York is an illustration of a repeatered circuit. Fig. 9(a) shows the location of the terminals and an available repeater location in a central office. Each of the two cable spans is within the range of the flat gain input and output amplifiers, although the network amplifiers could have been used to some advantage.

The principles of circuit layout for multi-link circuits have been developed to meet the requirement imposed by the wide range of existing repeater location spacings.

By providing only coarse steps of equalization at each repeater, the minimum complement of equalizers and amplifiers is employed. Only two factors need be taken into account in determining the coarseness of equalization. These are the overload limit of the output amplifier and noise level at the succeeding input amplifier.

In the receiving terminal the circuit is equalized to close tolerances using the smaller fixed equalizers and the variable equalizers.

This layout principle is illustrated in the circuits of Fig. 9(b) and (c).

Fig. 9(c) shows an alternate circuit layout for the same cable spans. The transmitter and the repeater use network output amplifiers, but the cable losses are not high enough to permit the use of network input amplifiers. Although the 10-db equalizer and intermediate amplifier could be omitted from the repeater and still provide a high enough output level for the 43 db cable loss, no overall saving would result, since these units would then be added to the receiving terminal. In comparing the two circuit layouts it should be noted that the (c) layout has one less equalizer and intermediate amplifier than the (b) circuit layout.

PERFORMANCE CHARACTERISTICS

Realization of the performance objectives was confirmed in the field trial of a representative two link A2A circuit. The circuit was installed between 30 Rockefeller Plaza and 32 Avenue of the Americas in New York using facilities leased from the New York Telephone Company. Figure 9(a) shows the cable route, and Figure 9(b) shows the circuit layout. This installation was made in June, 1954, and tests were in progress over a period of about 10 months.

Equalization

The measured overall gain-versus-frequency characteristic is given on Figure 10. The residual gain ripples are less than ± 0.04 db up to about 4.8 mc. Above this frequency the cut-off shape is gradual; the 6 db loss point occurs at about 7 mc.

The relative ease and speed of achieving this degree of equalization flatness is one of the features of the A2A system contributing to reduced maintenance cost. The process of setting the 9 dials of the "A" and "B" equalizers can be completed in about 10 minutes. Each dial is set by measurements at a particular frequency, making the overall circuit gain

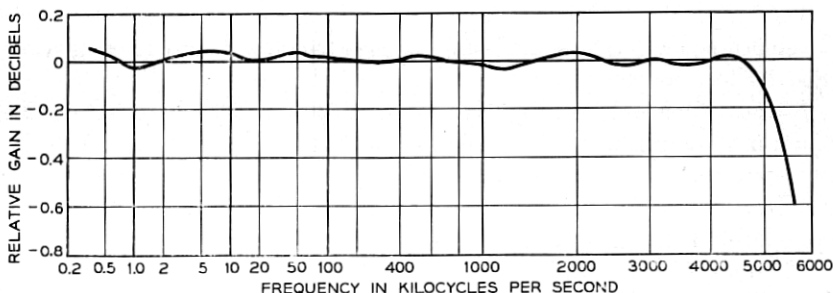

Fig. 10 — Overall gain characteristic of typical 5-mile circuit.

at that frequency equal to the gain at 300 kc. A test set for this purpose alternately sends the test frequency and the 300-kc reference. At the receiving end of the circuit the appropriate equalizer dial is adjusted for equal outputs at the two frequencies. The equalizer shapes⁶ and the sequence of their adjustment avoid interaction, making it unnecessary to repeat any dial adjustment. The lineup process yields 10 points on the gain-frequency characteristic which is usually a sufficient record of the performance, so that a complete gain frequency run need not be taken.

During ten months of the A2A trial the only change in variable equalizers required was correction for temperature change of the underground video cable. This was done periodically by adjustment of only one of the "A" equalizer shapes.

Signal-to-Noise

The presently accepted noise objective for a long television network is a peak-to-peak signal-to-r.m.s.-noise ratio of 45 db for "flat" or "white" noise.⁷ For random noise of other spectral characteristics a noise weighting shape is used.⁸ The shaping network used has a loss of 9 db to flat noise so that the signal-to-weighted noise objective becomes 54 db. The contribution to this total by all local video systems involved in such a network has been taken as a signal-to-noise ratio of 59 db. Considering the tandem usage of the local circuits, and the distribution of circuit lengths, an objective of 67.5 db for the minimum signal-to-noise performance of one A2A circuit link has been established.

The noise weighting used here includes the weighting versus frequency imposed by the NTSC color system. This is about 5 db more severe than the noise weighting for monochrome television, because the color information which is transmitted as a carrier signal at 3.58 mc over the transmission system is demodulated in the receiver to base-band frequency, where the noise presents a coarser pattern than the noise in the vicinity of 3.58 mc. The weighting also includes the low frequency noise shaping effects of the clamper.

The computed maximum link length to meet a 67.5-db signal-to-noise performance is 3.45 miles of cable for circuits using the flat gain amplifiers. The measured performance of this length of an actual circuit was 67.1 db. In the field trial circuit each of the two circuit links is shorter than this maximum spacing. The measured color weighted signal-to-noise performance of 71 db is in good agreement with the computed performance of 72.6 db.

The use of the network output and input amplifiers permits the maximum spacing to be increased to 4.8 miles for the same signal-to-noise performance as 3.45 miles with the flat gain amplifiers.

Differential Gain and Phase

In the NTSC color system, the color information is transmitted as a double sideband signal at a subcarrier frequency of 3.58 mc. The phase of the subcarrier contains the hue information and the amplitude controls the color saturation. This use of the high-frequency end of the band for color information imposes severe requirements on transmission, noise, and distortion. The change in phase at 3.58 mc with instantaneous signal level variations is known as the differential phase and causes variations in hue. The gain change of the system at 3.5 mc with instantaneous signal level variations is known as differential gain, and results in distortion in the color saturation.

The use of balanced amplifier stages with relatively wide band inter-stage networks has resulted in low differential gain and phase distortion. The differential gain and phase performance of the A2A system, of course, is dependent on the number of amplifiers used in each circuit. The 5-mile field trial circuit is representative of the performance of a long circuit. Measurements have been taken with the newly developed 47-A transmission measuring set.⁹ For the maximum signal voltage excursion the differential phase was 0.2° and the differential gain was 0.3 db.

DETAILED DESCRIPTION OF THE AMPLIFIERS

In this section the principal features of each of the six amplifier types will be described with reference to simplified schematics.

These designs use balanced amplifier stages for all applications including those requiring unbalanced terminations. Several advantages accrue from the use of balanced circuits. The most important of these is the reduction in distortion due to balancing the even order distortion outputs of the electron tubes. Equally important is the fact that the residual even order distortions will add on a random rather than systematic basis, in tandem amplifiers. Since the number of tandem amplifiers is expected to be the order of 50 in a large network the difference between systematic and random addition is appreciable.

The use of balanced stages also reduces the requirements on impedance of the DC plate supply permitting the use of non-electronically regulated rectifiers. By comparison, the A2 system uses a 10-tube regulated rectifier.

Triodes instead of pentodes are used for the input and output stages

of the flat gain amplifiers in order to obtain improved modulation and signal-to-noise performance. For the network input and output amplifiers pentodes are used to obtain high impedance terminations for the input and output networks.

The interstage video coupling networks use conventional circuits, but the band width at the 0.1 db relative loss point is made approximately 9 mc. The required sacrifice in gain to obtain this wide band yields several advantages. Transmission deviations within the 4.5-mc band of the system due to element deviations and capacitance variations in the tubes are greatly reduced. In addition the differential phase performance of the amplifier is improved.

The principal mechanism causing the differential phase in these amplifiers may be explained as follows. The instantaneous video signal voltage on the control grid results in a modulation of the effective grid-cathode capacitance, in turn producing a differential phase shift in the interstage network. The reduced impedance level of the 9-mc interstage compared to one for a narrower band results in a smaller differential phase shift. Here again, the even order components are suppressed by the balanced circuit arrangement.

Output Amplifier

A simplified schematic of the output amplifier is shown on Fig. 11. Alternate input terminations are provided to handle either a 150-ohm balanced input when used at a television operating center, or a 75-ohm unbalanced input at a broadcaster's location. Parasitic capacitances shunting the resistive termination are built out with small inductors to provide an input impedance with a return loss greater than 40 db up to 5 mc.

A manual gain adjustment is provided to compensate for flat gain deviations caused by variations in electron tubes and in addition, to furnish some range for system purposes. The gain of the amplifier is controlled by a potentiometer between the cathodes of tubes V1 and V2 in the input stage. The range of control is 10 db and the working gain of the amplifier is 11 db. This variable local feedback also causes the plate resistances of the tubes to vary depending upon the setting of the potentiometer. Since the plate resistances of the tubes contribute to the effective load resistance of the first interstage, any change in these resistances results in a change at high frequencies in the interstage gain-versus-frequency characteristic. To compensate for this effect a small positive feedback is introduced by cross-connecting the voltage

drop across the peaking coil of the interstage network to the cathodes of tubes V1 and V2 by means of 2 mmf capacitors. At the higher frequencies, these capacitors couple a small current of phase opposite to that of the cathode current through the potentiometer resistance thereby reducing its voltage drop. Hence the relative gain of the stage is increased at higher frequencies by an amount equal to the gain reduction caused by the increase in plate resistance.

To make the high-frequency input impedance substantially independent of the gain potentiometer setting, cross-neutralization of the grid-plate capacitance is employed. In the absence of neutralization, the grid-to-plate capacitance would be a function of the feedback introduced by the gain potentiometer.

Conversion of unbalanced input signals to a balanced drive for the output stage is provided by the large longitudinal feedback in the cathode circuit of the first stage. Further increase in balance takes place in the output stage which also has longitudinal feedback in the cathode circuit.

The interstage network of the output amplifier uses shunt peaking of a standard type with constants derived for flat amplitude response with a bandwidth of about 9 mc. The small phase distortion in the 4.5-mc band is equalized by the fixed cable equalizers.

A new method for aligning the variable inductor of the interstage network has been developed for the A2A system. Previously the alignment procedure required the measurement of the gain-frequency characteristic at several frequencies for each interstage, isolated from all other frequency shaping components of the circuit. In the new method the measurement is made at one frequency only. No isolation of the stage under adjustment is required, and the test equipment has no requirement on flatness of gain characteristic.

The procedure is illustrated by the simplified schematic of an interstage network given in Fig. 12 where R is the interstage resistance, L is

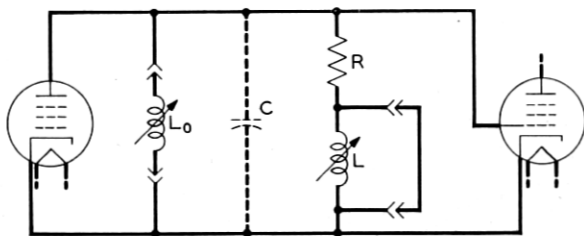

Fig. 12 — Amplifier interstage alignment.

the adjustable peaking coil, and C is the total parasitic capacitance. At low frequencies C and L have negligible effect on the impedance of the network, and the gain of the stage is proportional to R only. The objective is to adjust L for equal gains at 4.5 mc and low frequency. The first step is to short out L , and anti-resonate C at 4.5 mc by the addition of the test shunt inductor L_o . If the test coil has no dissipation, the interstage impedance will be R , and the gain at 4.5 mc will be equal to the low-frequency gain of the network. The 4.5-mc output is then measured at any convenient point in the circuit beyond the interstage. The second step is to remove the test coil L_o and the short circuit around L and adjust L to yield the same output reading obtained above, thereby making the gain at 4.5 mc the same as the low-frequency gain.

In the actual circuit a fixed inductance test coil shunted by a variable condenser is used instead of a variable inductor in order to maintain a constant Q . Because of dissipation in the test coil, and the fact that the parasitic capacitance is distributed, and several other small factors, the interstage resistance at the anti-resonant test condition is reduced below R . This is offset by adding a low resistance in series with the shorting plug used to short out L , making the total resistance again equal to R . Test jacks are accessible from the apparatus side of each panel to facilitate making the alignment.

The series circuit containing a 4-mf capacitor in the interstage network of the output amplifier provides a low-frequency gain step to compensate for the phase shift of several RC coupling circuits. Since the input and output amplifiers are always used in pairs the low-frequency compensation of the output amplifier is proportioned to correct for the time constants of the coupling circuits of both amplifiers.

At all frequencies within the 4.5-mc band, the output impedance of this amplifier approximately matches the characteristic impedance of the transmission line which it terminates. This is accomplished by the line terminating network which, when terminated in 62 ohms on each side to ground, presents an impedance equal to that of the line down to about 200 cycles. The 62-ohm terminations are provided by resistors in parallel with the plate resistance of the output tubes. In order to reduce the effects of parasitic capacitances in shunt with these terminations, the grid-to-plate capacitances of tubes V3 and V4 are cross-neutralized.

The center point of the output termination connects of a 25-henry inductor in series with the 200-volt dc plate supply. Its function is to raise the longitudinal output impedance so as to reduce low frequency longitudinal interference currents, principally at 60 cycles arising in the 16-gauge video cable conductors.

The longitudinal feedback in each stage of the amplifier maintains constant the sum of the cathode currents of the two tubes of each stage. A differential grid bias potentiometer provides a means for making the cathode currents equal. These controls are shown on Fig. 11.

The electron tubes in all of the A2A amplifiers are operated at a heater voltage of 6.1 volts instead of the nominal 6.3 volts in order to obtain increased life. This reduced voltage must be regulated to a close tolerance to insure adequate thermionic emission. The 115-volt 60-cycle voltage applied to each amplifier panel is regulated to about ± 1 per cent. In addition the filament transformers contain thermistor networks to reduce heater voltage changes due to transformer temperature changes. Provision is made in each amplifier to measure the activity of each tube on an in-socket but out-of-service basis. To make the measurement the heater voltage is reduced from 6.1 to 5.7 volts by means of a switch on the amplifier panel. The reduction in heater voltage is accompanied by a change in the grid-cathode bias, the magnitude of which is a measure of the relative age of the tube.

Input Amplifier

The input amplifier provides the first block of gain in A2A receiving terminals and repeaters. The circuit is described with reference to Fig. 13, which shows a simplified schematic.

The amplifier uses two balanced triode stages and provides 10 db of voltage gain into the unbalanced 75-ohm equalizer which follows it. It will be noted that several of the circuit features are similar to those of the output amplifier.

Cable termination is provided by the line terminating network in series with 62-ohm resistors. Small inductors, provide high frequency peaking to compensate for the parasitic capacitance of the input tubes and coupling elements.

Suppression of longitudinal noise voltages arriving over the cable is obtained by means of the 418A tetrode V3 connected in the common cathode circuit of V1 and V2. This constitutes local feedback such as to reduce the gain of the stage to longitudinal signals and minimize their modulation of metallic signals. A tube is used because it presents a high resistance to ac currents and a low resistance to dc currents, whereas a resistor would present high resistance to both ac and dc currents. A low dc drop across this resistance is desirable because it conserves power supply voltage.

The output circuit uses two 417A triodes in a cathode follower circuit

ponents. The modulation effects of bobble are due to the high bobble currents in the electron tubes. In most of the amplifier stages high longitudinal resistors used in the common cathode circuits prevents large current changes. However, in the output circuits as in Fig. 13 this condition does not hold and special means to suppress this effect are required.

In the input amplifier this is done by a balancing method. Referring to Fig. 13, a resistance divider couples a fraction of the bobble voltage on the 200-volt supply to the grid of the longitudinal tube V3. The longitudinal current that flows in the load resistors of V1 and V2 due to V3 is equal in amplitude and opposite in phase to the bobble voltage coupled from the plate supply. The resulting balance reduces the effect to a tolerable value.

Intermediate Amplifier

Fig. 14 shows a simplified schematic of the intermediate amplifier. It furnishes 24 db of gain between 75-ohm unbalanced terminations in repeaters and receiving terminals.

Most of the component circuits are similar to those already described. The first stage is comparable to that of the output amplifier. The low-frequency phase compensation circuit is placed in the input circuit instead of in the interstage network. The compensation is for low-frequency coupling elements in the intermediate amplifier only.

The output stage will be recognized as the same circuit used in the input amplifier. The output terminates in a 75-ohm equalizer over a short length of cable so that the output impedance requirements are lenient as for the input amplifier.

The intermediate stage of the amplifier uses 404A pentodes since it operates between high impedances. The interstage network and the provision for one-frequency alignment are the same as those already described.

As in the input amplifier a circuit for suppressing power supply bobble in the output is required. The method employed is a balancing arrangement wherein the bobble gain of the middle stage is so proportioned that the amplified bobble voltage of that stage is made equal to the direct bobble voltage applied from the power supply to the plate circuit. Referring to Fig. 14, the bobble input to the grids of V3 and V4 arrives via the plate feed. The bobble output appearing across the plate coupling resistors just equals the direct bobble voltage from the power supply. Since the two voltages are of opposite phase a cancellation takes place,

and the bobble voltage on the output stage grids is reduced with corresponding reduction of the modulation. The increased longitudinal gain of V3 and V4 is restricted to low frequencies by means of a by-pass condenser.

Receiving Terminal Amplifier

The receiving terminal amplifier shown on Fig. 15 supplies the last block of gain in each A2A circuit. Optional 75-ohm unbalanced or 124-ohm balanced outputs are provided to handle terminals at either customer's premises or television operating centers.

Nominally the gain is set to 20 db for 75-ohm output or 23 db for 124-ohm output. Additional gain is available for compensating the variable flat loss of the "A" equalizer, and for setting the overall circuit equivalent from transmitter to receiver. The cathode potentiometer in the first stage has a 10 db range of gain control, and a 75-ohm switchable loss pad provides an additional 7 db of control.

The first and second stages of the amplifier are very similar to the corresponding gain stages of the output and intermediate amplifiers. Compensation for low-frequency phase shift in the coupling circuits is provided by a low-frequency peaking circuit in the second interstage. It will be noted that the compensation is only on one side of the balanced circuit. The large longitudinal suppression of the output stage corrects the low frequency unbalance thus introduced.

The output of the receiving terminal amplifier connects to the broadcaster's equipment or to the television operating center over cables which may be as long as 500 feet. Over this length of cable good termination is required to keep echoes due to reflection down to requirements. For this reason the economical output circuit used in the input and intermediate amplifiers cannot be used here. A conventional plate output is taken from the triode connected 418-A tubes. Wiring options permit either balanced or unbalanced output.

Network Input and Output Amplifiers

These amplifiers are very similar to the flat-gain counterparts which have been described above. The principal difference is the use of networks⁶ that provide a rising gain shape in each amplifier.

In the network output amplifier the 418A output tubes are operated as tetrodes to provide a plate impedance high relative to the high side resistance termination of the network. The reduced transconductance of the tetrode compared to the triode is offset by the reduced interstage

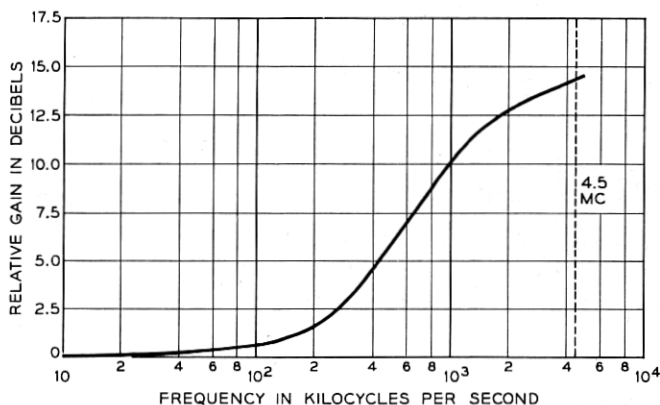

Fig. 16 — Gain characteristic of network input and output amplifier.

capacitance to make the operating low frequency gain of this amplifier substantially the same as the flat-gain output amplifier. Gain margin is provided to handle tube variations.

The overall gain shape of the amplifier is shown on Fig. 16. The gain step-up is 14.5 db at 4.5 mc.

In the network input amplifier the first stage tubes are 404A pentodes, in order to achieve a high impedance shunting the input network termination. The use of pentodes diminishes the benefits of the input network in two ways. Since the transconductance is lower, the amplifier has about 3 db less gain at low frequencies than the flat-gain input amplifier. The higher noise of the pentode compared to an equivalent triode reduces the noise advantage of the input network by about 4 db.

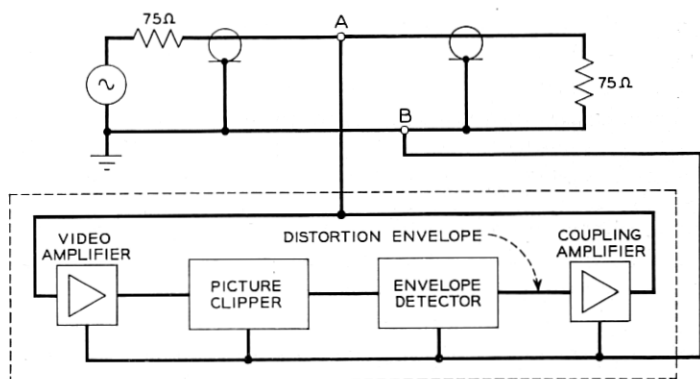

Fig. 17 — Block diagram of clamper.

The input network is similar to the network of the network output amplifier. The line termination elements are an integral part of the network and appear as a shunt circuit across the input, whereas the line termination in the network output amplifier is a series circuit.

The relative transmission is shown on Fig. 16. Variable cathode feedback as a continuous gain control is not used since it would result in a variable input capacitance terminating the high side of the network. Instead, a 3 db switchable pad is provided in the 75-ohm output of the amplifier to be used as a coarse gain adjustment. The continuous gain controls of the subsequent amplifiers in a receiving terminal or repeater are used to set levels accurately.

Clamper

The A2A clamper is an electronic circuit which samples the crest level of each sync pulse of a video signal and subtracts the envelope, derived by the sampling, from the transmitted signal. Since the derived envelope closely approximates any low-frequency interference or distortion which may have been superimposed during transmission, subtraction reduces this interference or distortion to a small residual amount.

This clamper¹⁰ is a feedback device which bridges or operates in shunt with the 75 ohm line as shown in the block diagram of Fig. 17. The composite television signal at the bridging point A-B is amplified; the picture portion is removed by a clipper, and the remaining signal (composed only of sync pulses containing the distortion information) is applied to an envelope detector. The detector output, representing the envelope, is returned to the transmission line at the bridging point by means of a coupling amplifier. Since this feedback envelope is nearly equal in amplitude and opposite in phase to the original distortion envelope, substantial cancellation occurs on the line.

The circuit arrangements for performing these functions are similar to those shown in Reference 10.

Passive Transmitting Terminal

This transmitting terminal uses a wide band video transformer² to convert the unbalanced signal from the customer to a balanced signal for transmission over the video cable. It is intended for use in short cable circuit applications where pre-equalization at the sending end is not required.

Fig. 18 shows a schematic of the terminal. The impedance matching

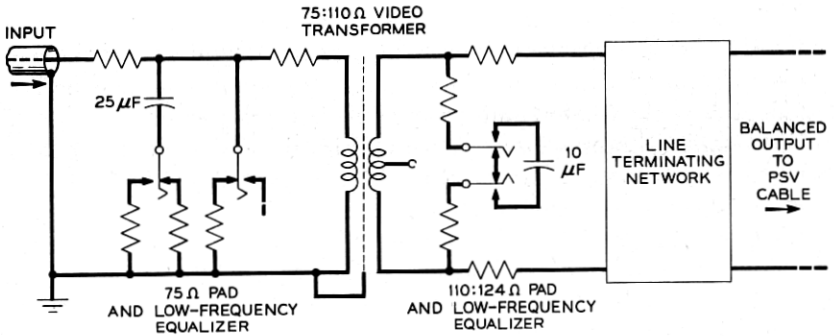

Fig. 18 — Schematic of passive transmitting terminal.

pad in the output side of the circuit converts the 110-ohm impedance of the video transformer to 124 ohms which is the high-frequency asymptotic impedance of the cable pair. The pad at the input serves as impedance correction and as isolation between the broadcaster's circuit feeding the terminal and the outgoing cable.

The loss pads also provide a means for compensating for the transmission effects of the low-frequency cut-off of the transformer. Low-frequency phase correction is accomplished by inserting capacitors in the shunt arms of the pads as shown on Fig. 18. The compensation is made

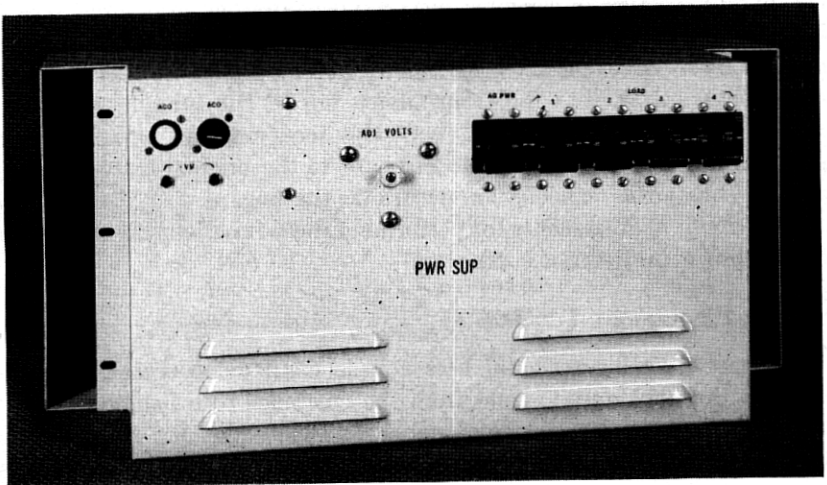

Fig. 19 — Regulator and alarm panel.

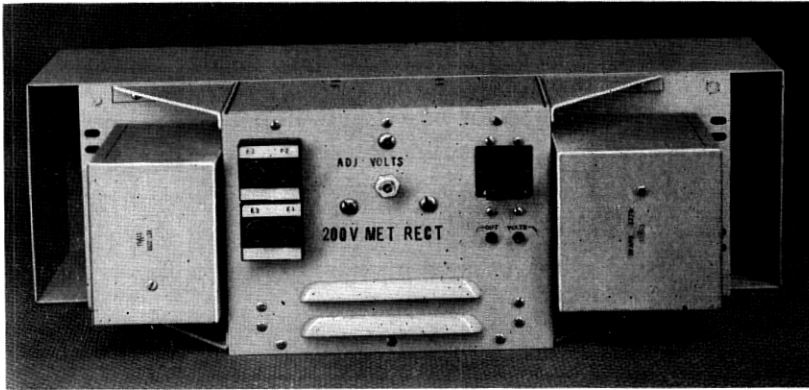

Fig. 20 — Rectifier.

adjustable in four steps by means of two keys to accommodate manufacturing variations in the transformer loss shape at low frequencies.

The line terminating network is the same network used in the output and input amplifiers. The center tap of the balanced winding of the transformer is ungrounded to maintain a high impedance to the flow of longitudinal interference currents.

Power Supply

The A2A system operates entirely from 115-volt 60-cycle commercial ac power. The power supply equipment consists of two units, a regulator and alarm panel, and a 200-volt rectifier. These panels are pictured in Figures 19 and 20.

The regulator and alarm panel uses an ac voltage regulator of the ferro-resonance type to supply closely regulated voltage to the rectifier and to the individual filament transformers of each amplifier. An adjustable auto transformer is provided to set initially the output voltage of the regulator for each amplifier filament load condition. The regulator thereafter will correct for variations in line voltage.

The rectifier is a conventional circuit using a selenium bridge stack and can supply a maximum output of 625 milliamperes at 200 volts dc. One of these rectifiers is required for the largest receiving terminal or repeater, but it can supply more than one of the smaller units. For example, three transmitting terminals may be supplied from one rectifier. An adjustable auto transformer permits setting the output voltage for each amplifier load combination.

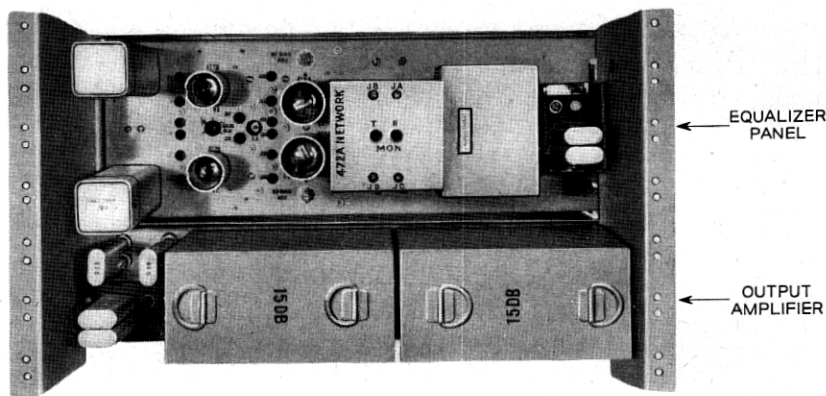

Fig. 21 — Typical transmitting terminal.

Overload protection is provided by fuses in the rectifier and by circuit breakers in the regulator and alarm panel. The alarm feature provides for triggering the central office alarm system for either dc or ac voltage failure or overload current in the circuit breakers or fuses.

A saving of 40 to 50 per cent in power input compared to an equivalent A2 repeater or receiving terminal has been achieved by the use of magnetic regulators and metallic rectifiers instead of electronically regulated rectifiers.

Equipment Mounting Arrangements

All of the equipment panels and assemblies are designed to mount on standard 19" duct-type bays. These bays are available in 11½-foot height for use in central office installations and in 6- and 7-foot heights for use in "off-premise" locations such as quarters provided in a customer's building. Portable cabinets are also provided for use in temporary circuit arrangements.

Fig. 21 shows the physical arrangement of the panels for a typical transmitting terminal, less the power equipment. The upper panel is the output amplifier which occupies 7" of vertical space. This panel is mechanically insulated from the supporting framework by means of rubber mountings to reduce microphonic effects due to mechanical shocks or vibrations.

The equalizer panel, occupying 3½ inches of panel space, provides mounting space for two equalizers and two loss pads for gain adjustment. The transmitting terminal pictured is arranged for balanced

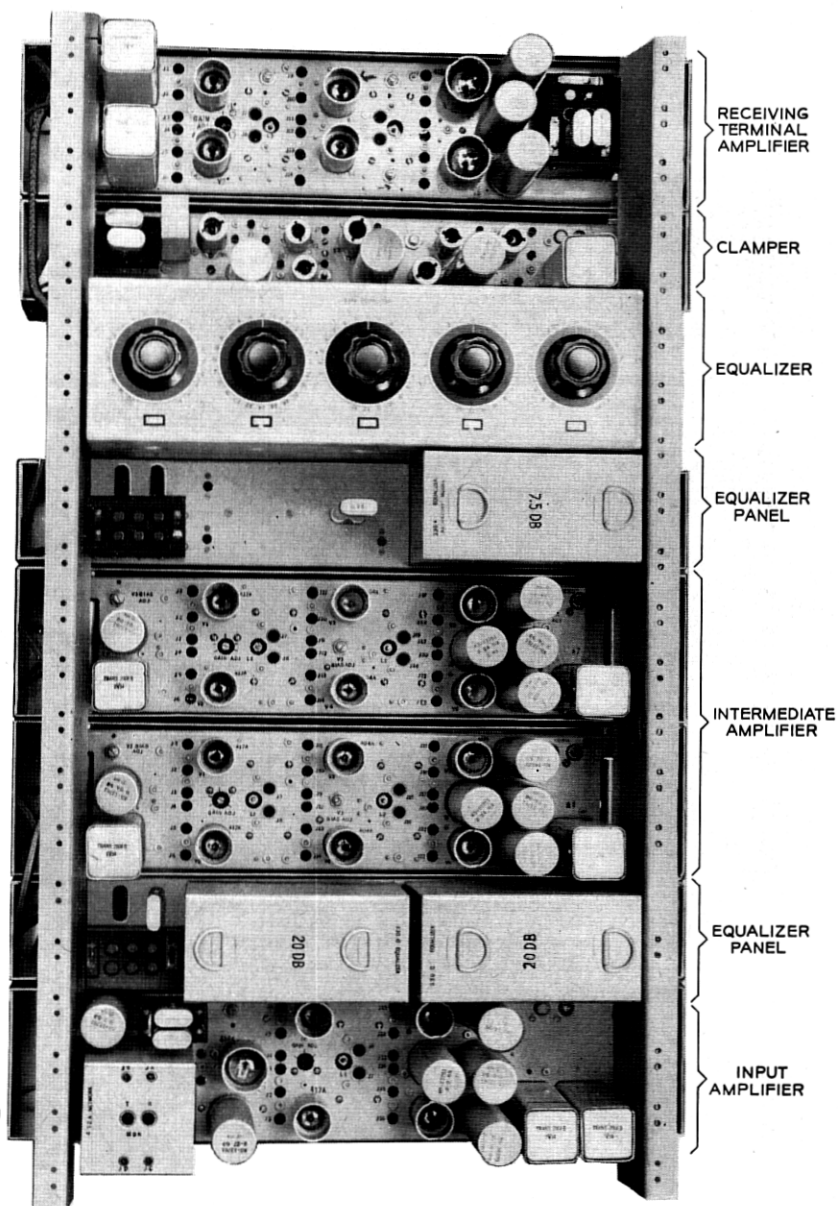

Fig. 22 — Typical receiving terminal.

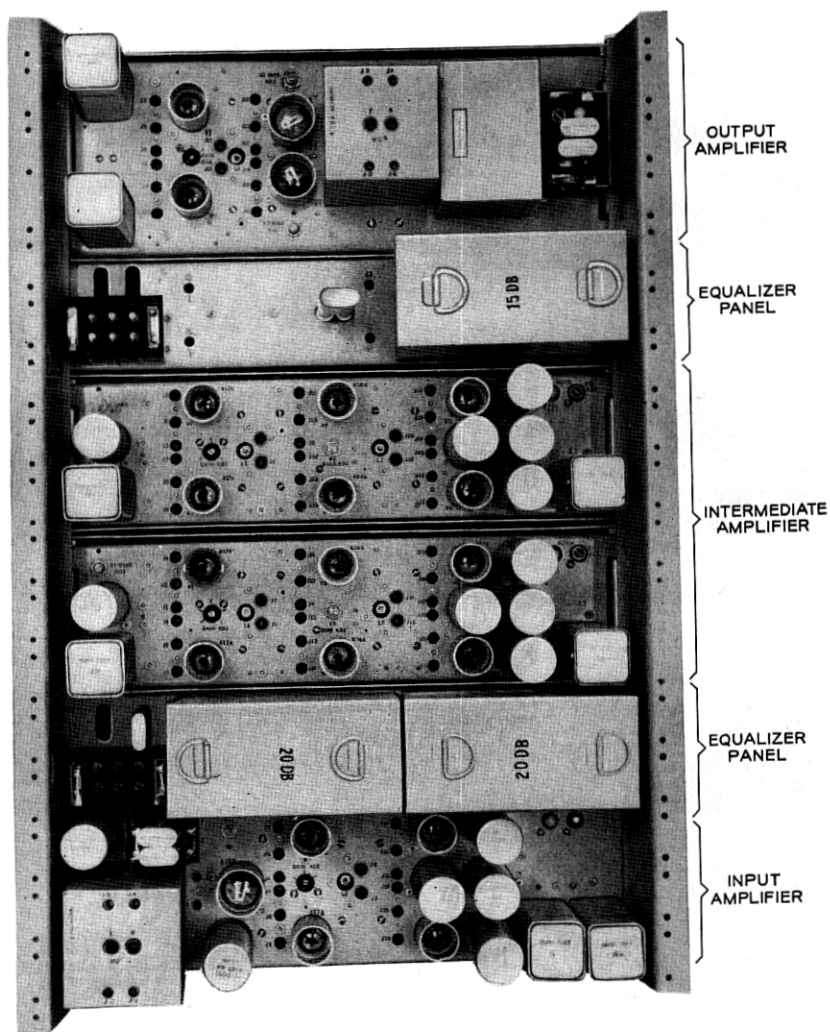

Fig. 23 — Typical repeater.

input, and uses two equalizers in a balanced connection. The manner of attachment of the equalizers to the equalizer panel is illustrated in Fig. 24. Connections are made through coaxial jacks and plugs, and snap fasteners are used to hold the equalizer in place.

The receiving terminal pictured on Fig. 22 contains the maximum complement of amplifiers, and occupies about 3 feet of bay height, exclusive of the power equipment. The progression of the circuit is from the input amplifier at the bottom to the receiving terminal amplifier at the top. Two 20-db fixed cable equalizers associated with the two intermediate amplifiers are mounted on one of the two equalizer panels. The second equalizer panel is shown with one fixed equalizer. The unused space on this panel is available for the variable "B" equalizer when this is required.

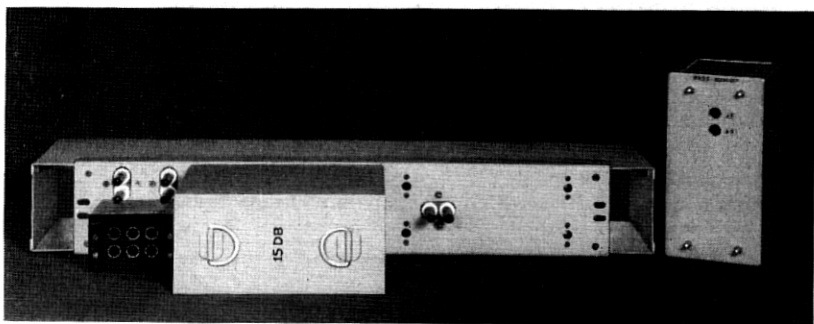

Fig. 24 — Equalizer panel and plug-in equalizers.

The variable "A" equalizer which is required for all circuits is permanently wired in.

Coaxial jack or plug access is provided for the terminal as a whole, and also for each component amplifier and equalizer. This feature facilitates maintenance testing, and permits temporary replacement of a panel by the use of patch cords in event of failure.

The repeater of Fig. 23 contains the maximum number of amplifier panels and occupies about $2\frac{1}{2}$ feet of vertical space on the bay, exclusive of the power equipment. The equipment features are the same as those of the transmitting and receiving terminals.

ACKNOWLEDGMENT

Although this account of the A2A system has been presented by only two persons, the authors wish to stress that the development of the

system represents the combined accomplishment of a large number of people in several areas of the Laboratories, of members of the Pacific Telephone and Telegraph Company, and the American Telephone and Telegraph Company on loan to the Laboratories.

REFERENCES

1. Abraham, L. G., Progress in Coaxial Telephone and Television Systems, A.I.E.E. Trans., **67**, Part II, pp. 1520-1527, 1948.
2. Nebel, C. N., Local Wire Video Television Networks, A.I.E.E. Trans., **69**, Part II, pp. 1451-1460, 1950.
3. Roetken, A. A., Smith, K. D., and Friis, R. W., The TD-2 Microwave Radio Relay System, B.S.T.J., **30**, pp. 1041-1077, Oct., 1951.
4. The L3 Coaxial System, B.S.T.J., **32**, pp. 779-1005, July, 1953.
5. Windeler, A. S., Video-pair Cable, Bell Laboratories Record, **26**, pp. 201-204, May, 1948.
6. Rounds, P. W., and Lakin, G. L., Equalization of Cables for Local Television Transmission, page 713 of this issue.
7. Mertz, P., Data on Random Noise Requirements for Theatre Television, J.S.M.P.T.E., **57**, pp. 89-107, Aug., 1951.
8. Barstow, J. M., and Christopher, H. N., The Measurement of Random Monochrome Video Interference, A.I.E.E. Communication and Electronics, **73**, Part I, pp. 735-741, Jan., 1954.
9. Kelly, H. P., Differential Phase and Gain Measurements in Color Television Systems, A.I.E.E. Trans., **73**, pp. 799-802, Sept., 1954.
10. Doba, S., Jr. and Rieke, J. W., Clampers in Video Transmission, A.I.E.E. Trans., **69**, Part I, pp. 477-487, 1950.