

Protection of Service in the TD-2 Radio Relay System by Automatic Channel Switching

By I. WELBER, H. W. EVANS, and G. A. PULLIS

(Manuscript received December 3, 1954)

The TD-2 radio relay system spans the continent and provides for transmission of hundreds of telephone conversations or several television programs. The effect of even an occasional failure would be so great that means have been provided to restore service quickly and automatically when a failure occurs. The operation and circuits of this automatic channel protection switching are described.

INTRODUCTION

When communication systems fail, provision must be made to restore service as rapidly as possible. In systems providing only a few telephone circuits, restoral may be by manual rearrangement of the circuits affected so that they are made good on stand-by or alternate facilities. But in the case of systems carrying a large number of telephone channels or network television, the impact of a system failure is so great that automatic arrangements must be provided to restore service much faster than is possible by manual operations. This need led to the development of the automatic protection switching system for the TD-2 radio relay system,¹ which has in recent years come to provide a large portion of the Bell System's long-haul telephone and television facilities.

The TD-2 system provides six two-way radio channels, any one of which will carry several hundred telephone circuits or one television signal. It is used generally as a long-haul backbone route system, principally between major centers of population. Repeater stations are provided at intervals of about thirty miles, depending on considerations of terrain, and the number of repeaters between the terminal points is a function of course of their geographical separation. Frequency modulation is used, and the repeaters do not reduce the signal to its original amplitude modulation form, so that the base-band is not normally available at repeaters intermediate to the terminal points.

One of the six two-way radio channels is reserved as a protection channel for use when a regular channel used in telephone or television business has been interrupted. The automatic protection switching system consists, in general terms, of devices which detect an interruption or degradation of transmission of each regular channel, and devices which substitute the protection channel for the regular channel in trouble. The latter devices comprise both switches and circuits to control them.

Some TD-2 systems are so long that it is desirable to divide them into shorter sections called Switching Sections. The protection channel is subject of course to the same vicissitudes that interrupt the regular channels. These vicissitudes occur on a per repeater section basis, so that the greater the number of repeater sections in a switching section, the greater the time that the protection channel will not be available, and also the greater the total time that the regular channels will require the protection channel. It will be shown that the probability of interruption of a regular channel is proportional to the number of repeaters in each switching section. The number of repeaters per switching section represents an economic balance between the degree of reliability desired and the cost of the automatic switching equipment. In practice, the average number of repeaters per switching section is 10, with a range of from 5 to 15 except for certain special cases where even fewer than 5 repeaters are protected.

Since switching arrangements must be provided at the ends of the switching sections, which may be at repeaters other than terminals, it is necessary to examine the condition of the radio channels at intermediate frequency rather than at baseband. A channel switching initiator is associated with each radio channel at the receiving end of each switching section, and comprises a frequency modulation receiver and a noise detector. It will detect the presence of abnormally high noise near 8.5 mc, well above the frequencies usually transmitted over the system, and the absence of carrier. Either condition is symptomatic of system failure or degradation.

Each switching section is a separate entity, in that information is not exchanged between adjacent switching sections. Thus if a failure occurs in the first of several switching sections, high noise may be detected by the channel initiators in all the switching sections, even though a switch to the protection channel is needed in only the first section. Spurious switches are prevented by switching control arrangements. When a channel initiator indicates a possible failure, the regular channel with which it is associated is bridged at the transmitting end of the switching

section to the protection channel. If transmission is found to be deficient on both the regular and protection channels, as would be the case for troubles in a preceding section, no switch results. This feature also prevents switches from a marginal though usable regular channel to a totally interrupted protection channel.

SERVICE INTERRUPTIONS

Radio systems are subject to two types of interruptions: equipment failures, which will usually completely interrupt transmission until repairs can be made by men dispatched to the point of failure, and radio fades. The duration of fades is short compared to that of equipment failures but the fades occur so frequently during certain periods that they are objectionable.

Equipment Failures

Even though the individual tubes and components that make up the equipment of the TD-2 system have very creditable life figures, they do sometimes fail, and the impact of their failure on system performance is serious because of the enormous number of tubes and components involved. Thus between Los Angeles and New York in each direction of transmission there are more than 450 416-type Western Electric vacuum tubes used as microwave amplifiers or modulators and more than 1,100 tubes of other types directly in the transmission path, plus over 1,000 tubes used in such auxiliary functions as the generation of microwave frequencies. Failure of any one tube or any of its associated components will cause an interruption to transmission. Every possible precaution is taken to avoid these failures, and considerable improvements have been made in repeater station reliability since the TD-2 system was first placed in service.

Radio Fading

Microwaves used for radio relay systems propagate through the atmosphere, which is a dielectric whose characteristics vary with pressure (altitude), moisture content, temperature, etc. These factors may vary from point to point along the path to such an extent that the transmission medium is so nonhomogeneous that several discrete transmission paths exist between a radio transmitter and a radio receiver.² These paths may differ in length so that at some frequencies signals may arrive via two paths with such phase relationship that one signal cancels the

other, resulting in a radio fade.* These fades are usually very short in duration compared to equipment failure interruptions because the dielectric character of the transmission path is continually changing with motion of the air. Since the existence of a fade is predicated on a natural coincidence of factors involving frequency, position of the antennas relative to one another and the micrometeorology of the path, it is apparent that fades are not likely to occur at two frequencies at the same time, or on two paths at the same time. Thus the effect of radio fading can usually be counteracted by use of either space diversity, which provides two transmission paths and selects the better, or frequency diversity, which provides two transmitting frequencies and selects the better. Frequency diversity was chosen for the TD-2 automatic switching system because it also provides more thorough protection against equipment failure than is possible with space diversity.

Radio fading in most sections of the country is most apt to occur in summer months when the moisture content of the air is higher. Also during the summer months fading is most apt to occur during the night hours when there is less air motion than in the day. Fortunately the worst fading occurs during early morning hours, say 3 to 5 A.M., when television and telephone demand has been low. The fading observed on a single path in Ohio during a typical summer night is shown in Fig. 1. The net effect of a fade is an increase in telephone or television circuit noise, as shown in Fig. 2 for the telephone case. If the fade is so deep that the carrier-to-noise ratio at the repeater input approaches unity, the signal drops off as well, but this is beyond the point where noise is considered intolerable.

Fading measurements have been made on many paths in many parts of the country for considerable periods of time, and also several continuous observations of telephone channel noise have been carried on, so that a considerable body of data was available on which to base predictions of fading performance.

The maximum rate of change in path loss with time during a fade is also of interest, since this is one of the factors that determines the time within which the protection system must operate. Several hundred deep-fades were examined, and the average maximum rate of change in path loss was found to be about 10 db per second. It is believed that rates as high as 100 db per second occur very seldom. Because the switching system takes approximately $\frac{1}{20}$ second to operate, the path loss at the

* There are other types of fades, as described in Reference 2, which have other causes. Multipath transmission causes almost all of the fading observed on TD-2 systems. "Earth-bulging" fades have been observed, but very rarely.

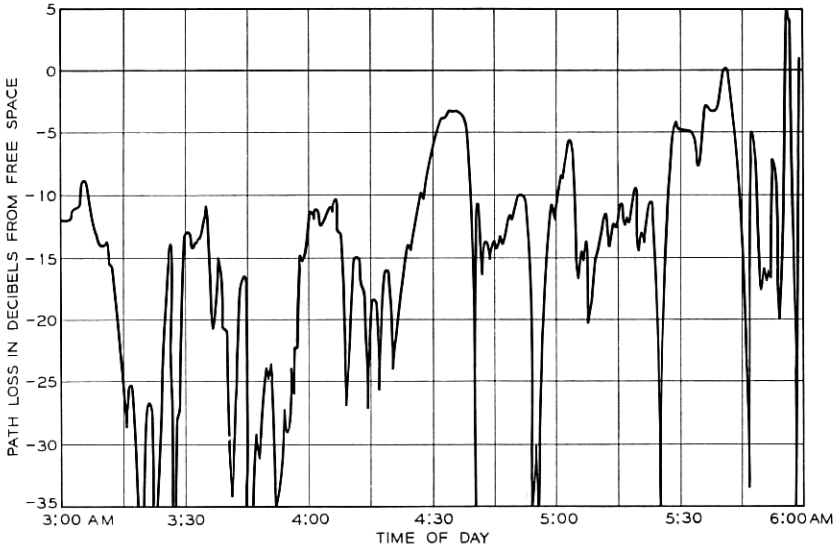

Fig. 1 — Heavy summer fading, Bryan-Wauseon, Ohio.

actual instant of operation may be 0.5 db greater than at the instant the channel initiator called for a switch, and for some fast-moving fades this figure may be as much as 5 db.

Expected Improvement in Reliability

The objective of the automatic protection switching system is, of course, to make the TD-2 system as reliable as possible, consistent with frequency availability and economic considerations. The frequency space available in the 4,000-mc common carrier band permits operation of six broadband channels on a route, and if the frequency space is to be used most efficiently only one channel can be used for protection purposes. Perfect reliability cannot be achieved because (a) the protection channel is subject to the same causes of failure as are the regular channels and (b) occasionally two regular channels fail at the same time, and the single protection channel can restore only one of the failed channels.

Obviously the greater the number of regular channels protected by a single protection channel, the higher the probability that simultaneous failures will occur on two regular channels. Also, the greater the number of repeaters in a switching section, the greater the number of demands on the protection channel and the greater the probability that the protec-

tion channel itself will fail. It is economically desirable that switching sections be long, since switching equipment is expensive. The number of points at which switching equipment must be provided depends on the degree of improvement needed to increase the reliability to an acceptable point.

It is convenient to discuss the degree of improvement in reliability separately for equipment failures and for fading. The probability of interruption with automatic switching of a one-way channel because of equipment failure is shown in Appendix I to be:

$$P = R \frac{(N + 1)}{2} np^2$$

where p = the probability that any one-way repeater will be in a failed condition,

n = the number of repeaters per one-way channel in each switching section,

N = the numbers of regular channels, and

R = the total number of repeaters per one-way channel.

From data on incidence and duration of equipment failures an average figure for p is

$$p = 0.05 \text{ percent} = 0.0005$$

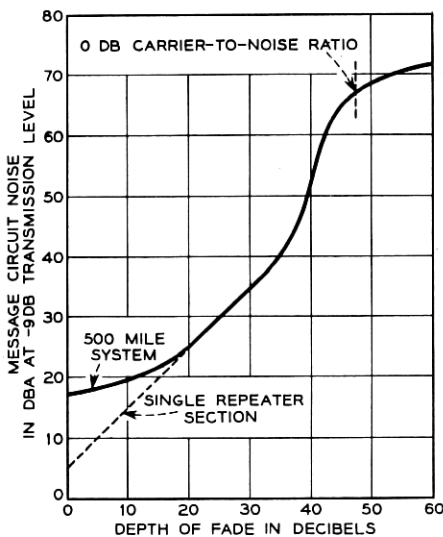

Fig. 2 — Fluctuation noise in the top channel of a 480-channel message system due to a fade in one repeater section.

Typical values for n and N are

$$n = 10$$

$$N = 5$$

Reliability figures are frequently quoted on a 4000-mile basis, since this is representative of the longest circuits the Bell System provides. This corresponds to a total of 133 repeaters, assuming 30-mile spacing, so

$$P = 0.001 = 0.1 \text{ per cent}$$

This is less than two minutes per day.

Without automatic protection switching, the probability of interruption of a one-way 4,000-mile (133 repeaters) TD-2 channel would be 6.65 per cent or 96 minutes per day, which is obviously excessive. Thus, the outage time due to equipment failure with no protection whatsoever is 66 times the outage time with automatic protection switching. This figure, interestingly enough, is independent of the length of the system.

Of course the automatic system replaces manual switching rather than no protection at all, and it is difficult to estimate the effectiveness of manual switching, so that the degree of improvement over manual switching cannot be stated.

The improvement in reliability associated with atmospheric fading is computed in the following manner. Let us consider a typical switching section of ten repeater sections, and let us assume that the fading over this route is equivalent to that observed experimentally on the New York-Chicago TD-2 system between midnight and 8 A.M. (heaviest fading hours) in August (heaviest fading month) 1950 (typical fading year). The noise distribution for the unprotected system is shown in Fig. 3, designated, "No Switching." The noise in the top channel of a 480-channel telephone system would exceed 40 dba at the -9 db transmission level point 0.11 per cent of the time. In a 4,000-mile system made up of thirteen such switching sections the noise without automatic protection switching would exceed 40 dba 1.43 per cent of the time. This is excessive.

Now let us assume that the ten repeater switching system is equipped with an automatic switching section arranged to switch to a protection channel when the message circuit noise exceeds 40 dba. As in the case of equipment failures, the protection channel is not always available when needed. It might have failed or might be busy making good another regular channel which has failed. Also, the protection channel at the instant when it is needed might be experiencing a fade even deeper than the regular channel with which we are concerned, and in

this case the switching system must be able to recognize that no switch should be made. This probability was evaluated by R. L. Kaylor from experimental studies of the loss versus frequency of a large number of fades.³ As would be expected, there is a greater probability that a fade will affect two channels immediately adjacent in frequency than two channels separated in frequency. For this reason the protection channel is wherever possible at the extreme end of the band (usually the low-frequency end, since channels are installed in sequence, and a protection channel is needed no matter how many regular channels are installed).

Summarizing these factors for the switching section of ten repeaters and five regular channels, the protection channel availability is given in Table I.

Since the protection channel is unavailable 9 per cent of the time, the fraction of the time that the telephone circuit noise exceeds 40 dba at the -9 db transmission level point will be reduced from 0.11 per cent of the time when unprotected to 9 per cent of 0.11 per cent, or 0.01 per cent of

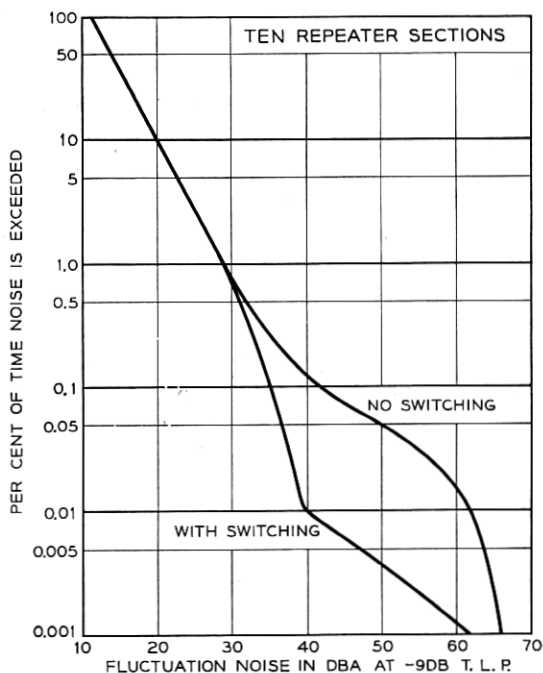

Fig. 3 — Fluctuation noise in the top channel of a 480-channel message system during heavy summer fading, with and without automatic protection switching.

TABLE I — PER CENT OF TIME PROTECTION CHANNEL IS NOT AVAILABLE
 Hypothetical Six-Channel Ten Repeater TD-2 System
 Heavy Summer Fading

Condition	Per cent Time Unavailable
Fading: protection channel worse than regular channel . . .	2.54*
Equipment: protection channel in trouble	0.5
Fading: two regular channels in simultaneous fades	3.84*
Equipment: protection channel in use by another regular channel	2.0
Total unavailability	9 per cent

* These are average figures. They differ from channel to channel because of differing frequency spacings to the protection channel and to adjacent channels.

the time when protected. Similarly the percentage of the time by which any levels of noise greater than 40 dba are exceeded are reduced to 9 per cent of their unprotected values. The noise distribution to be expected from the ten-repeater switching section of five regular channels is shown in Fig. 3, designated "With Switching."

In a 4,000-mile system made up of such switching sections the noise would exceed 40 dba 0.13 per cent of the time. This figure is for heavy summer night time fading. For evening hours, the percentage would be in the order of 0.024 per cent, and for seasons other than mid-June to mid-September much less. These figures correspond to an equipment failure outage of 0.1 per cent as discussed previously.

Thus the total outage time would be as given in Table II.

CIRCUITS OF THE AUTOMATIC SWITCHING SYSTEM

The circuits of this system can be classified into three main categories:

1. Switching circuits.
2. Evaluating circuits.
3. Control circuits.

The purpose of the switching circuitry is to transfer the TV or telephone signal from an impaired regular radio channel to the protection channel. The evaluation circuits determine when and where the transfer should take place, and when the transfer back to normal should be made. The control circuits are the connecting link between the evaluating and switching circuits and in forming this link, they accept information from the evaluating circuits and cause the switching circuits to operate. At the transmitting end of a switching section the switching is embodied in the transmitting IF switch and at the receiving end it is the receiving IF switch. The evaluating function is located at the receiving end of

TABLE II — PER CENT OF TIME REGULAR CHANNEL UNAVAILABLE
4,000 miles, 5 regular channels, ten repeater switching sections

	No Automatic Protection Switching		With Automatic Protection Switching	
	Heavy summer night	Heavy summer evening	Heavy summer night	Heavy summer evening
Equipment failure	6.65	6.65	0.1	0.1
Fading	1.46	0.03	0.13	0.02
Total	8.11	6.68	0.23	0.12
Automatic switching improvement factor			35	56

each section and it is performed by a unit called the channel initiator. The way in which these units and the control circuits are connected in a switching section is shown in Fig. 4.

Switching Circuits

At the transmitting and receiving end of a section the switching circuit is embodied in the transmitting and receiving IF switch. There are two units which form the fundamental building blocks in these switches as well as in other switching circuits in TD-2. These are the Bridging Amplifier and the 223-type IF coaxial switch. After describing them we will show how they are put together to form the IF switches.

Bridging Amplifier

The bridging amplifier is a device with a single input and two outputs capable of transmitting a band of 60 to 80 mc. A photograph of this unit is shown in Fig. 5. The path from A to B is a low pass filter with a cut off in excess of 400 mc so that transmission in the 60 to 80 mc band is flat, while the path from A to AB or B to AB passes through a one tube amplifier.

223 Type IF Coaxial Switch

The actual switching is accomplished by means of the 223-type IF coaxial switch. This unit is shown in Fig. 6 and a schematic in Fig. 7. As can be seen from the schematic, this switch has four transfers which operate simultaneously when voltage is applied to the windings. With no voltage across the windings the transmission paths are A to AB and B to

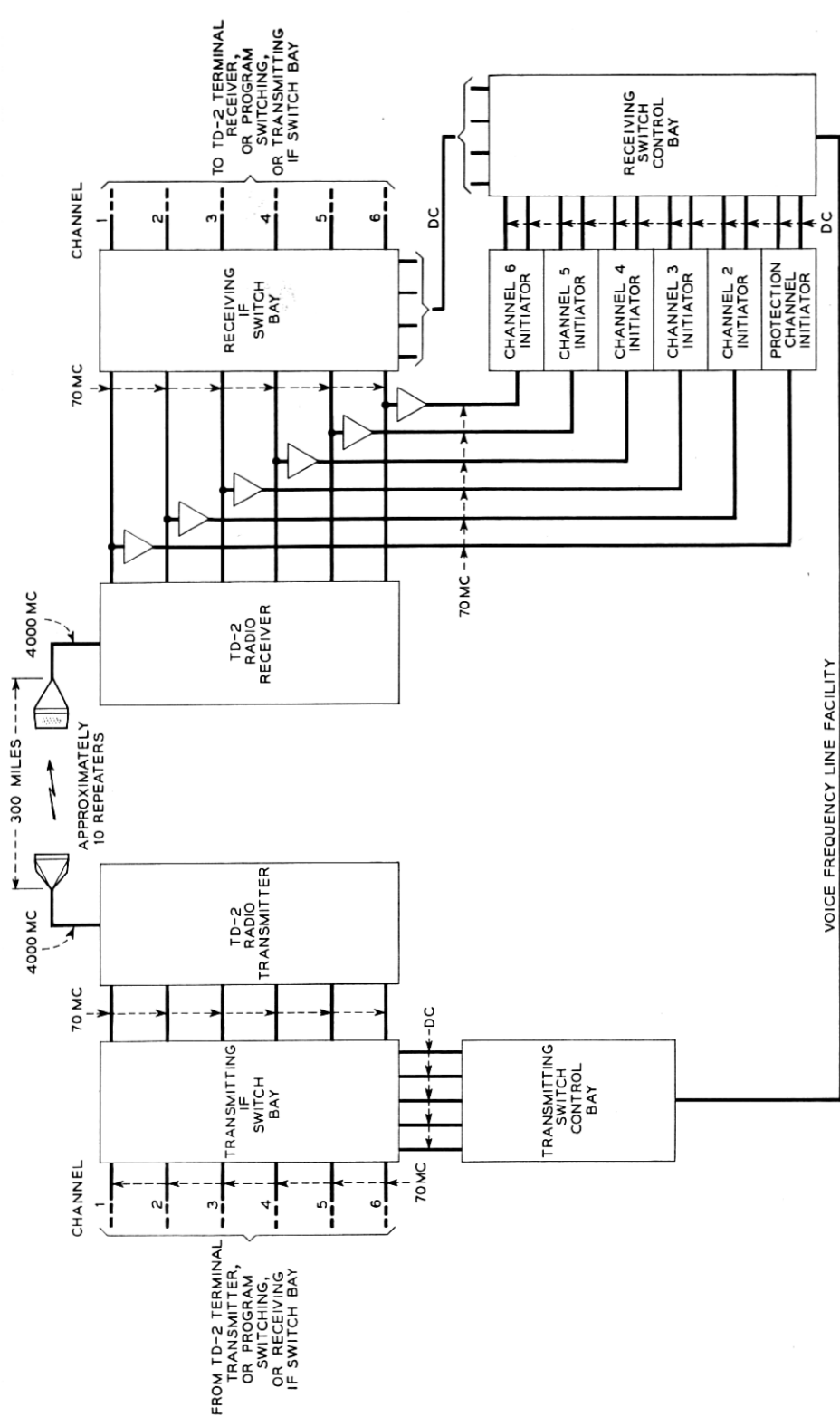

Fig. 4 — Automatic switching.



Fig. 5 — IF bridging amplifier.

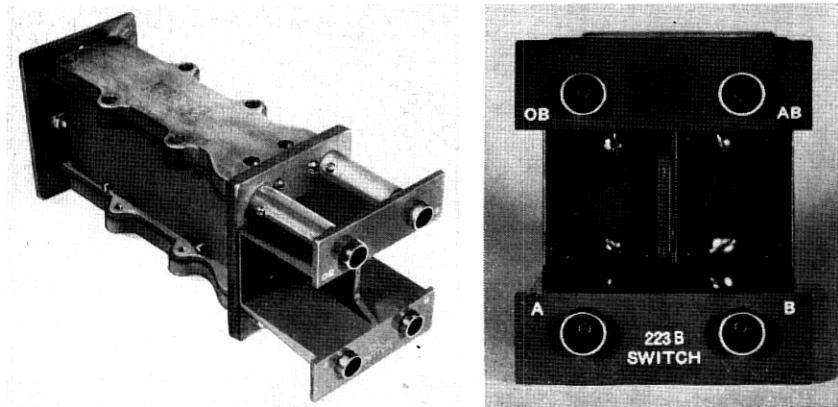

Fig. 6 — 223-type IF coaxial switch.

OB. Where the contacts are operated the transmission paths are A to an internal 75-ohm termination and B to AB. This arrangement of contacts is not the most economical insofar as number of contacts is concerned, however crosstalk between paths must be held to 90 db or greater and this arrangement was found necessary to keep the stray capacity between outputs to a minimum.

The structure of the transmission path in this switch is entirely coaxial and the switches themselves are glass enclosed reeds resting in a pool of mercury. By capillary action the mercury wets the reed and provides a positive contact. The operate time of the switch is 1.5 milliseconds.

Transmitting and Receiving IF Switches

As was mentioned previously, the bridging amplifier and 223 IF coaxial switch are used in combination to perform the job of the IF switching circuit. Fig. 8 presents in schematic form how these units combine to form the transmitting IF switch. Note that the operation of any 223 switch in a regular channel path causes transmission to be put on the regular and protection channel simultaneously. Note also that the active portion of the bridging amplifier is in the normal path. If the tube should fail, then the channel could be restored by an automatic switch. Finally, note the protection channel path which is shown as dotted. An operation of the 223 switch in this path will cause the protection pilot to be removed and the protection channel will be cut through the transmitting switch. This is done when the protection channel is committed to a service other than automatic switching.

A schematic of the receiving switch is shown in Fig. 9. The receiving switch operates under the control of the receiving switch control circuit. From the schematic the following points should be noted. First, the initiators are bridged on their respective channels at all times. A failure of the bridging amplifier will cause an automatic switch to take place

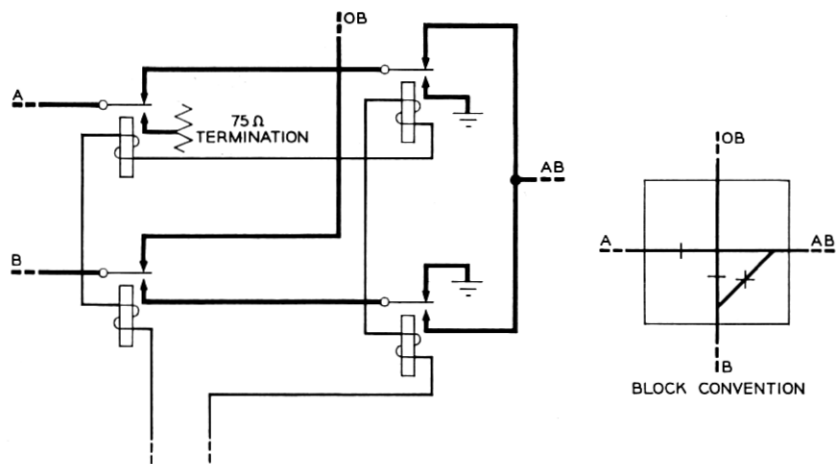

Fig. 7 — 223-type coaxial switch.

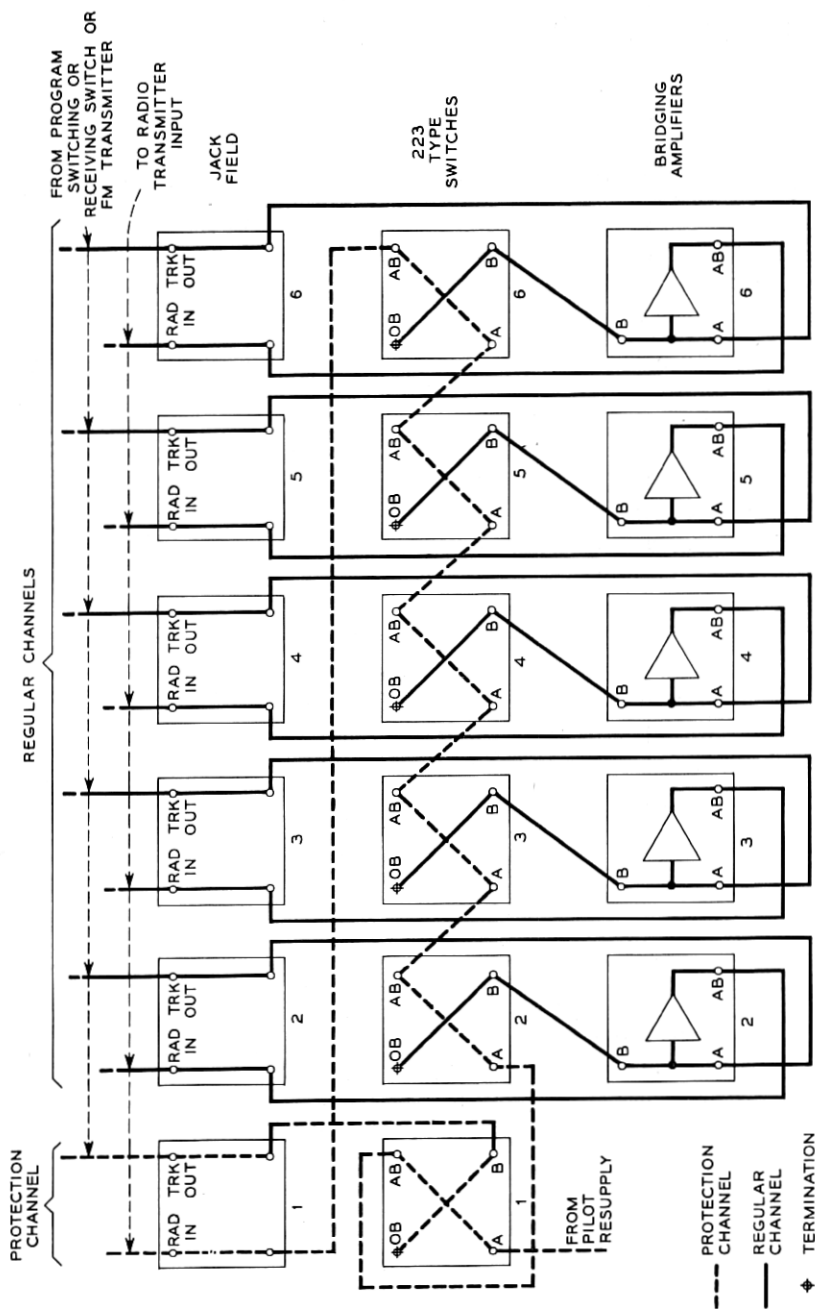

Fig. 8 — TD-2 auto switching transmitting switch.

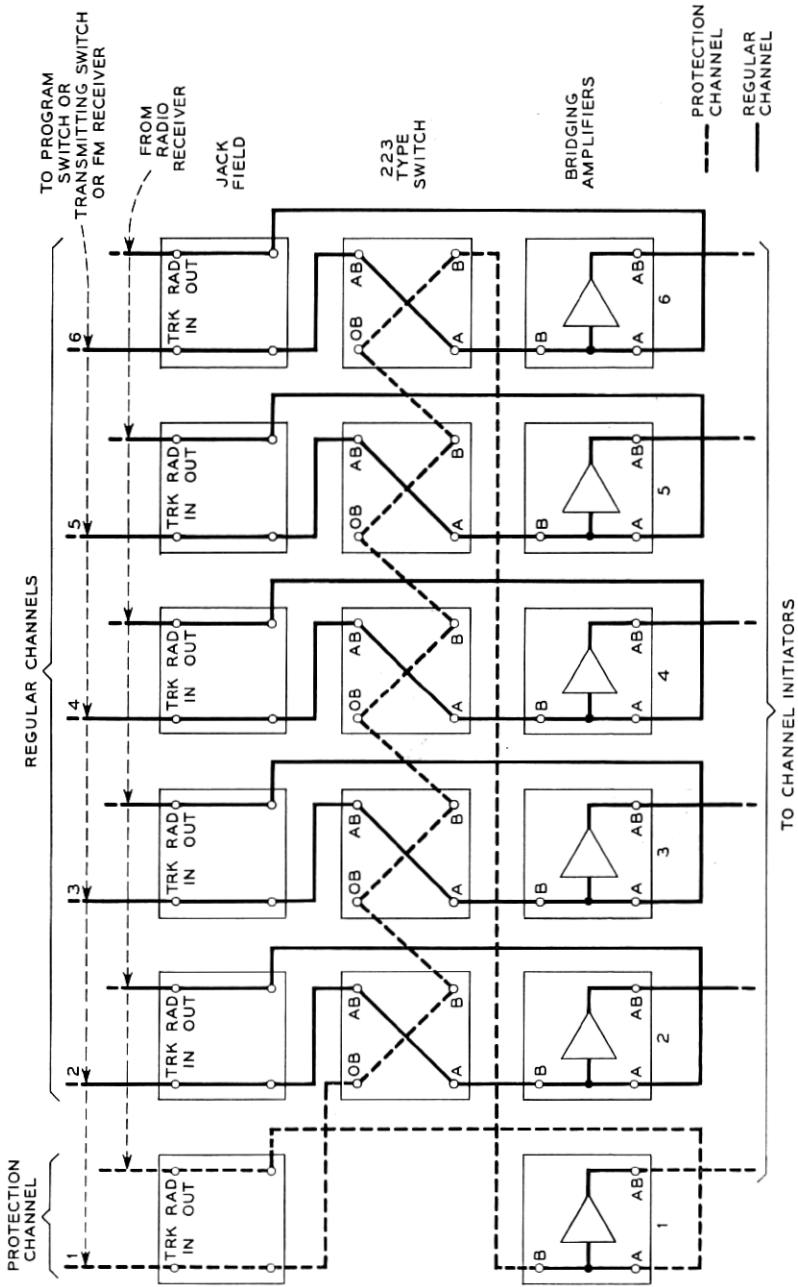

Fig. 9 — TD-2 automatic switching receiving switch.

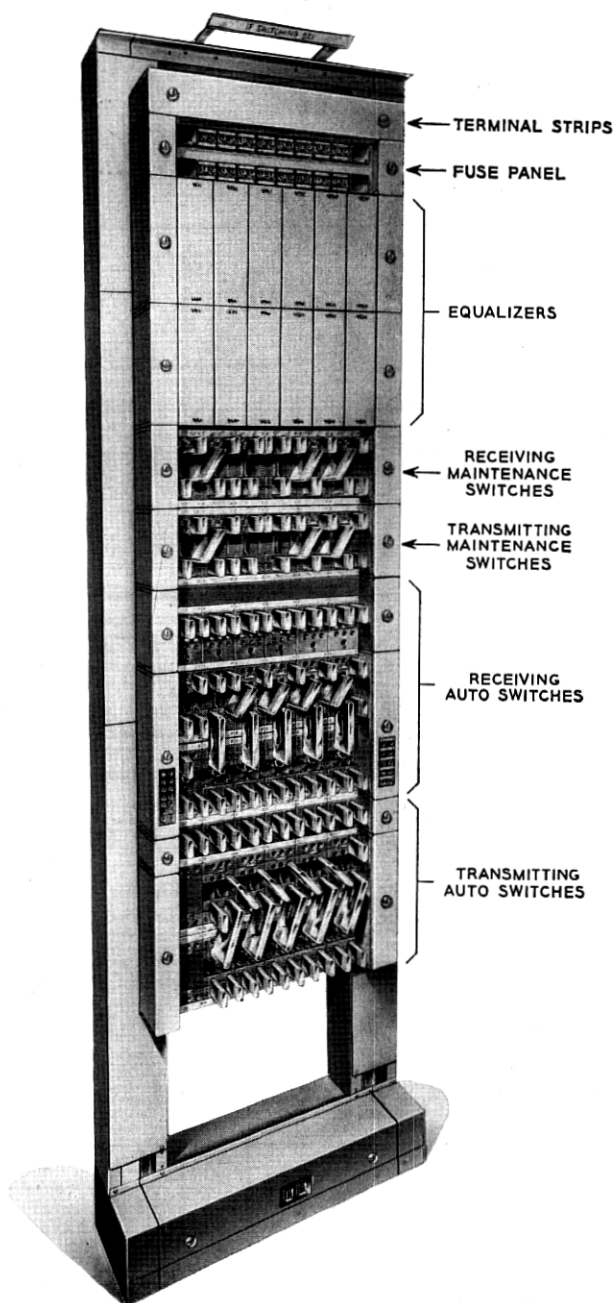

Fig. 10 — IF switching bay.

since the initiator will see no IF carrier. Second, the operation of any 223-type switch causes the incoming regular channel signal to go from the A jack on the 223-type switch to an internal 75 ohm termination. The protection channel is diverted by the operation of the switch and it then becomes the outgoing signal. The IF switching bay is shown in Fig. 10.

Evaluating Circuits

The initiators are the sensing circuits in this system and it is their job to evaluate the condition of a channel. The regular initiators monitor the working channels and by measuring the noise and the carrier level they determine if the channel is in need of protection. The protection initiator monitors the protection channel and by measuring noise and a pilot which is normally transmitted over this channel the initiator can tell if the channel is available for protection service. When a transmitting end switch is made, the protection pilot is removed and is replaced by a TD-2 carrier with message or TV modulation. If this signal is satisfactory the protection initiator then informs the receiving control circuit that a switch should be completed. If the signal is not satisfactory the switch is not completed. We will now describe briefly how the initiators perform their evaluating functions.

Regular and Protection Channel Initiators

A simplified block diagram of the regular initiator is shown in Fig. 11. One input signal to the regular initiator is a 70-mc carrier with frequency modulation in the form of TV or telephone information. Another input is an 8.9-mc regular pilot tone. The pilot, which is locally generated, amplitude modulates the 70-mc carrier so that the output signal of the receiver consists of the TV or message plus an 8.9-mc tone. If the 70-

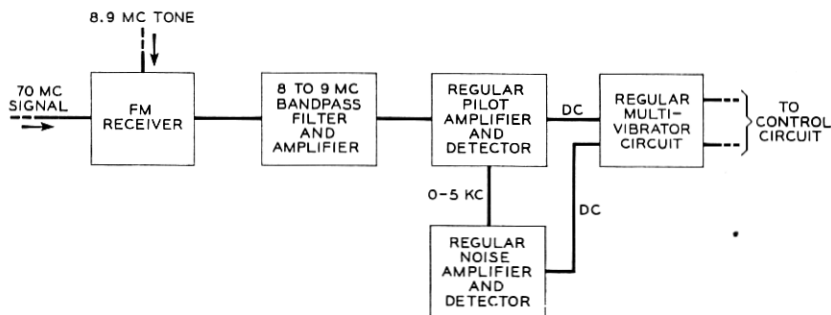

Fig. 11 — Simplified block schematic of regular initiator.

mc carrier is lost due to an equipment failure the 8.9-mc signal at the output of the receiver is also removed. At the output of the receiver is an 8 to 9-mc bandpass filter which removes the TV or telephone information and passes only the pilot tone and any noise around it. The pilot and noise are then amplified in a gain stabilized amplifier and detected. The DC portion of the detected pilot is fed into a bi-stable multivibrator. The ac portion of the detected pilot (which is noise) is amplified and detected. The dc due to the rectified noise is also fed into the multivibrator. Its output is connected to the Receiving control circuit for that particular channel. If the pilot should be removed (due to loss of carrier) or the noise should increase, the multivibrator will change its state and cause the control circuit to operate.

The protection initiator is quite similar to the regular and a simplified block diagram of it is shown in Fig. 12. One of the input signals can be either a 70-mc carrier modulated by an 8.5-mc protection pilot (when no switch has been requested) or a 70-mc signal with telephone or TV modulation (when a switch has been requested). The other input signal is a locally generated 8.9-mc tone, the same as in the regular initiator. This tone, as in the regular initiator, amplitude modulates either of the 70-mc input signals. The output signal of the FM receiver

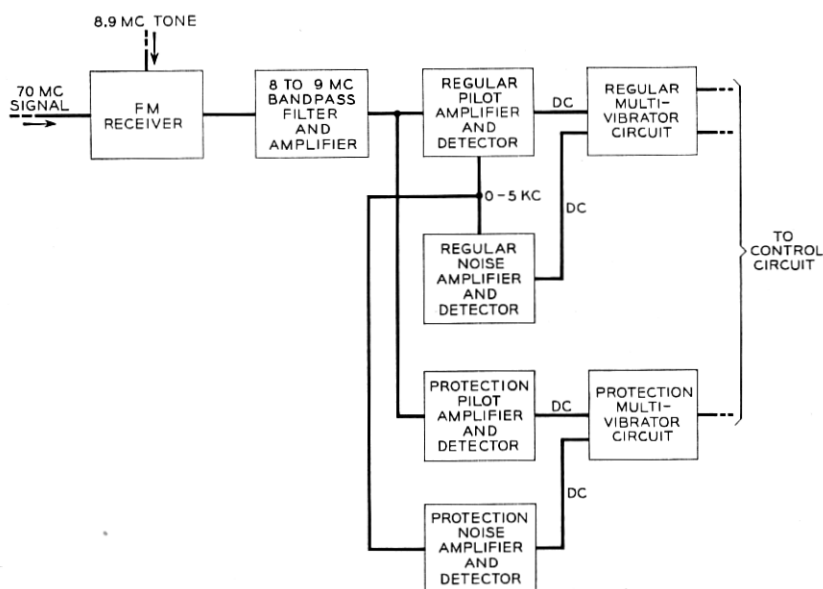

Fig. 12 — Simplified block schematic-protection initiator.

is, therefore, either a pair of tones at 8.9- and 8.5-mc or an 8.9-mc tone with TV or telephone modulation. The block units in the protection initiator are similar in form and function to those in the regular initiator.

At the output of the 8- to 9-mc filter and amplifier the signal is fed simultaneously into regular and protection pilot amplifiers. These amplifiers are tuned to their respective pilot frequencies. The detectors at the output of these amplifiers rectify the pilots and feed the dc voltage to the respective multivibrators. The ac portion (noise) of the regular pilot detector output is fed simultaneously to the regular and protection noise amplifiers. The noise around the regular pilot is used because this tone is constant in level and not affected by transmission vagaries as is the protection pilot. The two noise amplifiers are adjusted so that their gain is 5 db greater than the noise amplifier in the regular initiators. This greater sensitivity in the protection initiator noise amplifier guarantees that a switch will not be completed unless the noise on the protection channel is at least 5 db lower than on the regular channel.

The bi-stable multivibrators in the protection initiator are identical to those in the regular initiators. The output of the protection multivibrator informs the control circuits of the status of the protection channel.

Pilot Supply and Distribution Circuit

The description of the initiators referred to a locally generated 8.9-mc tone. This tone comes from a unit called the pilot supply. Since each initiator in an office requires such a tone, a distribution circuit is provided to divide the high level output of the pilot supply into a maximum of twenty equal low level tones.

The pilot supply consists of two identical units each having a crystal controlled oscillator, amplifier and limiter, and a single transfer circuit. The limiter serves two functions — it maintains the output at a constant level and the limiter current is used to operate the transfer circuit. Each of the units operates continuously — one serving as a standby. Their outputs feed into a 223 type coaxial switch. If one of the units fails, the transfer circuit sees a loss of limiter current from that unit and transfers the working unit to the output by operating the 223-type switch.

Protection Pilot Resupply Circuit

In our description of the system we have made frequent mention of the protection pilot. In our earlier remarks we also described how the TD-2 system was divided into switching sections of approximately 10

STATION

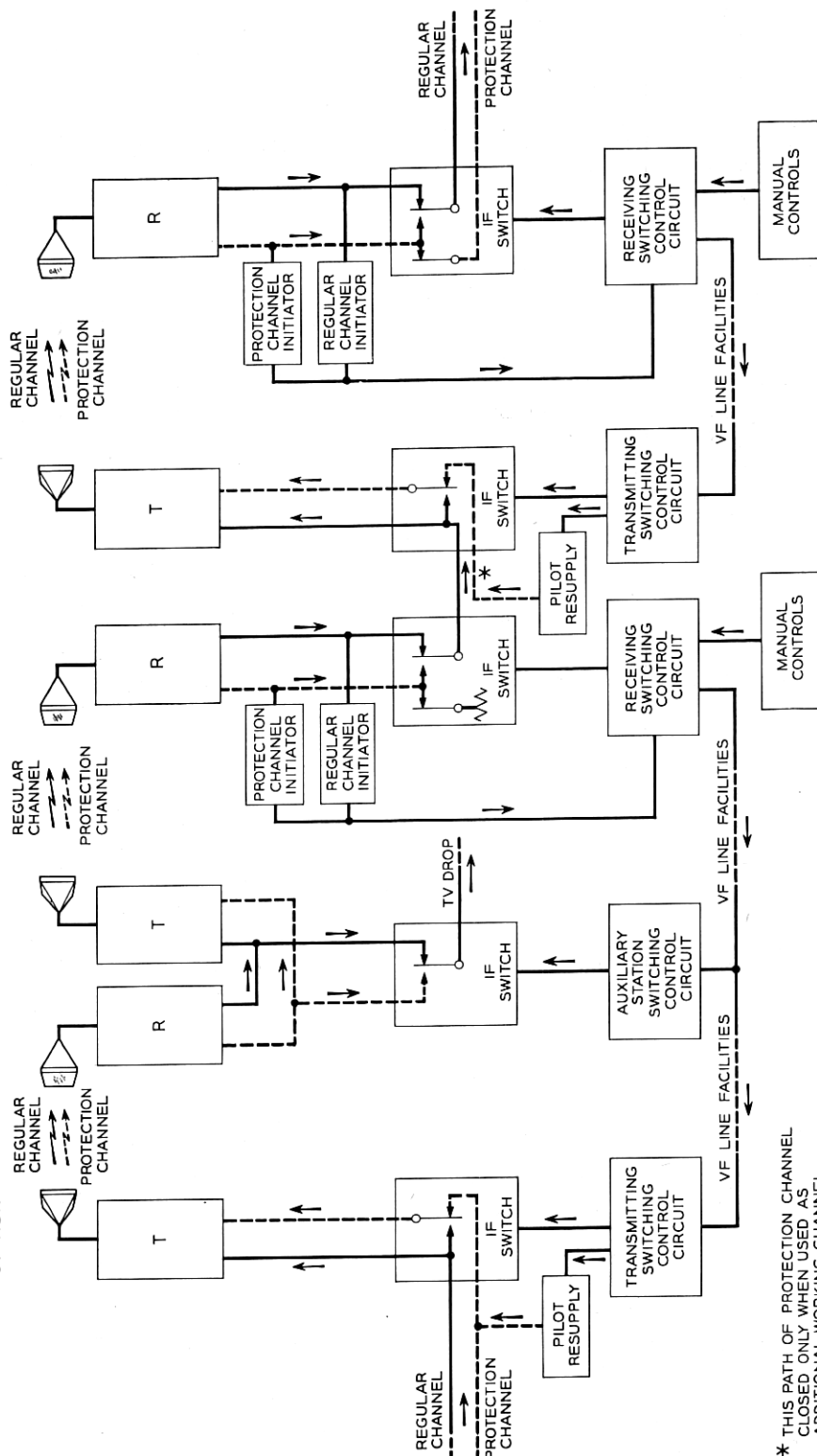

* THIS PATH OF PROTECTION CHANNEL
CLOSED ONLY WHEN USED AS
ADDITIONAL WORKING CHANNEL

Fig. 13 — Control circuits required for one direction of transmission for two sections of a TD-2 system.

repeaters. At the transmitting end of each section the protection pilot is inserted. One method of providing this pilot on the channel would be to have an 8.5-mc tone modulate a terminal transmitter. This becomes uneconomical since a terminal transmitter would have to be provided for each switching section. A signal which is equivalent to a carrier, frequency modulated by a single tone, can be obtained by adding two tones of the correct level and frequency and then passing the resultant through a limiter. A derivation in the appendix shows the requirements on level and frequency for this equivalence.

CONTROL CIRCUITS

The control circuits accept the signals from the channel initiators and cause the IF switches to operate and replace a regular channel by the protection channel. Fig. 13 shows in block form the arrangements of the control circuits required for one direction of transmission for two sections of a TD-2 system. Following is a brief discussion of the operation of the control circuits for the various transmission conditions of a system.

Regular Channel Failure

When all the regular channels of a section are working properly, a 700-cycle guard tone is transmitted over the voice frequency path from the receiving switching control circuit to the transmitting switching control circuit which holds the IF switches in a released condition. The purpose of the 700-cycle guard tone is to prevent the operation of the switches on extraneous signals, such as noise on the VF line, and to provide an indication that the voice frequency facility has not been impaired. When transmission on any one of the regular channels is impaired, the initiator associated with that channel sends a signal to the receiving switching control circuit. If the protection channel is available, the receiving circuit removes the 700-cycle guard tone, applies another tone depending on the channel in trouble, and enables the associated receive IF switch but does not operate it. Each channel has a discrete identification tone and the frequencies used for the five regular channels are 900 cycles, 1,100 cycles, 1,300 cycles, 1,500 cycles and 1,700 cycles. On the removal of the 700-cycle guard tone and the reception of the channel identification tone, the transmitting switching control circuit bridges the protection channel across the impaired regular channel and removes the 8.5-megacycle pilot frequency from the protection channel. The regular channel IF carrier, which is now applied

to the protection channel, causes the protection channel initiator at the receive end of the section to operate the previously enabled IF receive switch and transfer the outgoing regular channel to the protection channel, thereby completing the replacement of the impaired channel by the protection channel.

The IF switches at both ends of the section remain operated until the transmission of the replaced regular channel returns to normal at which time the initiator at the receive end of the circuit sends a signal to the receiving switching control circuit to release the receive IF switch and reconnect the regular channel through to the succeeding section. At the same time, the channel identification tone is removed from the voice frequency path and the 700-cycle guard tone reapplied. This results in the restoration to normal of the transmitting switching control circuit and the subsequent release of the transmit IF switch. When this switch releases, the bridge between the regular channel and the protection channel is opened and the pilot resupply circuit reapplies the 8.5-mc tone to the protection channel, thereby completing the restoration of all circuits to normal. However, during the period of time between the release of the receive IF switch and the reception of the protection channel 8.5-mc pilot tone, the receiving switching control circuit locks-out requests for the protection channel by all other regular channels. This feature is provided to assure that the receiving control circuit will not attempt to complete a new switch until all circuits at the transmit end of the section have returned to normal.

When the transmission of two or more channels in the same section is impaired at approximately the same time, the initiators of these channels will cause the receiving switching control circuit to apply tone toward the transmit end for each of the channels. No action will be taken at the "transmit" end at this time as the transmitting control circuit is designed to ignore the request for a switch when more than one channel identification tone is received. At the receive end, the control circuit locks out all but the lowest numbered channel. When the lock-out is completed, the tone of the lowest numbered channel only will be present on the voice frequency line and the transmitting control circuit will then operate the IF switch for that channel. If due to a trouble condition, the switch cannot be completed on the above mentioned lowest numbered channel within 50 milliseconds, that channel will be locked out by the receiving control circuit for a period of 10 seconds and the control circuits will try to complete a switch for the next lowest numbered channel requesting a switch. If a switch is completed all other channels will then be locked out until the protection channel

is again available, but if a switch cannot be completed for any of the channels the receiving switching control circuit will try again, at the end of the 10-second period mentioned above, to complete the switch for the lowest numbered channel then requesting a switch.

Voice Frequency Path or Protection Channel in Trouble

The above general discussion of the operation of the control circuits is based on the assumption that the voice frequency path between the control circuits is good and that the protection channel transmission is satisfactory. It is obvious that these conditions may not exist at all times and the control circuits have been designed accordingly. If the transmission of the voice frequency path fails after a switch has been completed, the switch will remain operated even though the transmitting switching control circuit no longer receives the channel identification tone. This is accomplished by a feature of the control circuit which recognizes the absence of both the guard tone and the channel tone, and which causes the switch to remain in the condition existing just prior to the loss of transmission on the voice frequency path.

If the transmission of the protection channel is impaired, the absence of the 8.5-mc pilot tone will cause the receiving switching control circuit to lock out requests from all regular channels and thereby will prevent the start of any switch.

Switch Request by Channel in Preceding Section

When a regular channel is impaired, a switching operation will be started on this channel in the succeeding switching sections provided the protection channel is available or not in trouble. When this occurs, the IF switches at the transmit ends will operate in these sections, but the IF switches at the receive ends will not operate. This is because the protection channel initiator will not see a good regular channel signal since the fault is in a preceding section. When the switch is completed in the section in trouble, the transmission of all the succeeding sections will return to normal with the result that all the control circuits of these sections will return to the condition dictated by the transmission within the respective sections. If, however, a switch cannot be completed in the section in trouble, the transmit switches in all succeeding sections as well as the section in trouble will remain operated for a period of approximately 50 milliseconds. At the end of this time the receiving switching control circuit of each section will lock out the channel in trouble for 10 seconds. The lock-out will remove the channel identifica-

tion tone from the voice frequency paths and will release the transmit IF switches. At the end of the 10-second lock-out period, the receiving switching control circuit will again attempt to complete the switch.

Auxiliary Switching Stations

There are network broadcast conditions which require that an auxiliary station provide transmission to locations not on the path followed by the "back-bone" or main line. An auxiliary station is equipped with a transmitting switching control circuit essentially the same as that provided at a transmit station except that a 2,100-cycle identification tone receiving circuit is furnished in addition to the identification tone receiving circuits for the regular channels. However, at the auxiliary station, the operation of the control circuit differs in that although it responds to the removal of the guard tone and the presence of the channel identification tone, it does not complete the switch. When the switch for the back-bone circuit is completed at the receive end of the circuit, the receiving switching control circuit transmits a 2,100-cycle tone over the voice frequency path to the auxiliary station. The control circuit at the auxiliary station then recognizes this tone and completes the previously enabled switch. If, after the switch has been completed the 2,100-cycle tone is removed from the voice frequency path, the switch will be maintained until the 700-cycle guard tone is reapplied to return the circuit to normal.

The presence of the 2,100-cycle tone on the voice frequency path does not influence the control circuit at the transmit end as it is outside the frequency limits of the filters used in the transmitting switch-control circuit.

Manual Controls

Although the switching system has been designed primarily for automatic operation there are occasions when manual switching is required. Typical conditions under which manual switching is used, and the operation of the control circuits for these conditions are as follows:

Manual Switch

By the simultaneous operation of a manual switch key and a master key, located at the IF switching bay or at a remote point, the receiving switching control circuit will start a switch just as if an initiator had requested a switch, except that the 50 millisecond timer will be disabled.

All regular channels and all other positions from which a manual switch may be started will be locked out. If the protection channel is not in use, the manual switch will be completed at both ends of the circuit in the same manner as if an automatic switch had been requested. A visual indication that a manual switch has been started is given by the lighting of a lamp at each location from which a manual switch may be initiated.

If the protection channel is in use for another regular channel at the time the manual switch is started, no action will be taken by the receiving switching control circuit as all manual positions will be locked-out.

Regular Channel Lockout

There are times when locking-out an impaired regular channel will give operating advantages by releasing the protection channel for use with the remaining regular channels. The lock out feature is accomplished by the simultaneous operation of a master key and the channel lock-out key.

Forced Manual Switch

Whenever a switch is completed, either automatically or manually, a lamp will light at all associated manual control positions. If a manual switch has been started and is not completed because of unsatisfactory transmission over the protection channel, the lamp will not light. However, as previously mentioned, the 50-millisecond timer is disabled when a manual switch is attempted and therefore the protection channel will remain bridged across the impaired regular channel at the transmit end of the circuit. This will permit transmission tests to be made on the protection channel and if these tests indicate that the protection channel transmission is suitable for service, the switch can be forced or completed manually by the simultaneous operation of the master key and the forced switch key. A channel lamp will light to indicate that the forced switch has been ordered.

Protection Channel Lockout

Traffic may demand that the protection channel be locked out of the automatic switching system and be made available as an additional working channel. This can be accomplished by the simultaneous operation of the master key and the lockout key. At this time, if the protection channel is available, the receiving switching control circuit locks out all the regular channels and transmits to the transmitting switching

control circuit the identification tone of the lowest numbered regular channel in addition to the 700-cycle guard tone. The transmitting switching control circuit recognizes the presence of both tones and removes the 8.5-mc pilot tone from the protection channel. A visual indication is given at the transmit end to show that the Pilot Resupply relay is operated and that the pilot tone is not applied to the protection channel. At the receive end of the circuit, a lamp will light to indicate that the lock out has been completed.

If the protection channel is not available when the proper keys are operated, a lamp will light at the receive end to indicate that the lock-out has not been completed. When the protection channel becomes available, the circuits will function as described above.

Alarms

The importance of each of the regular channels and of the protection channel makes it apparent that alarm features must be provided to indicate the failure of any channel or of the automatic switching system.

An automatic switch alarm circuit in conjunction with the receiving switching control circuit provides the following alarms:

1. A major alarm is operated when a regular channel fails and is not replaced by the protection channel within a few seconds.

2. Minor audible and visual alarms are operated to indicate failures on the regular and protection channels when the failure lasts for more than 15 to 45 seconds. The visual alarm indicates the number and direction of the channels in trouble.

3. A major alarm is also operated within a few seconds if the protection channel fails after it has been switched for an impaired regular channel or as an additional channel.

4. A major alarm is operated if a pilot re-supply circuit which provides the 8.5-mc tone for the protection channel fails, or if both generators in the pilot supply fail.

5. Minor audible and visual alarms are operated to indicate failure of a voice-frequency path. Two alarm lamps are lit for a failure. One lamp indicates that the voice-frequency path is in trouble and the other lamp indicates the direction of transmission.

EQUIPMENT ARRANGEMENTS

The automatic switching equipment is grouped together on a terminal basis. A terminal group for a switching section includes the receiving switching equipment for all incoming channels from a specific

point and also the transmitting switching equipment for all outgoing channels in the opposite direction to that point. Two such terminal groups, connected on a back-to-back basis, are required at an intermediate switching stations having two directions of transmission. When program switching facilities are required they are connected between the automatic switching groups.

The equipment used in both automatic and program switching is mounted in 9-foot high, 19-inch wide duct type bays. These bays are the same type as used on present TD-2 radio equipment. In each terminal group for automatic switching there are three basic bays. These are: The IF switching bay, the initiator bay, and the switching control bay.

The IF switching bay contains the receiving and transmitting IF switches for a particular direction. The capacity of this bay is six channels incoming and six channels outgoing (5 regular and 1 protection).

The initiator bay provides for a maximum of five regular initiators and one protection initiator. Provision is also made for an additional protection type initiator which may be used as a spare on regular or protection channels. The bay is arranged for double side maintenance with controls, meters, tube and jack appearances on the front or operation side. This bay is shown in Fig. 14.

There are two standard bay arrangements provided for the switching control equipment. One arrangement is used at the receiving and transmitting ends of a section and the other at an auxiliary station. The control equipment not mounted in these bays are the pilot resupply circuit which mounts on a miscellaneous basis, the alarm lamps which mount on a miscellaneous basis, and the manual switch controls which are mounted on the IF switch bay.

Switching Control Bays

The switching control bay, Fig. 15, accommodates the transmitting switching control equipment serving two to six radio channels to a particular point and the receiving switching control equipment serving two to six radio channels from the same point. The equipment mounted in the bay is as follows:

1. One *receiving switching control group unit* which provides basic control equipment for the receiving end of a switching section. This unit sends out the guard tone and also receives information from the protection channel initiator. A second oscillator mounts on this unit to supply the 2,100-cycle signal for auxiliary station drops.

2. A *receiving switching control channel unit* for each of the regular

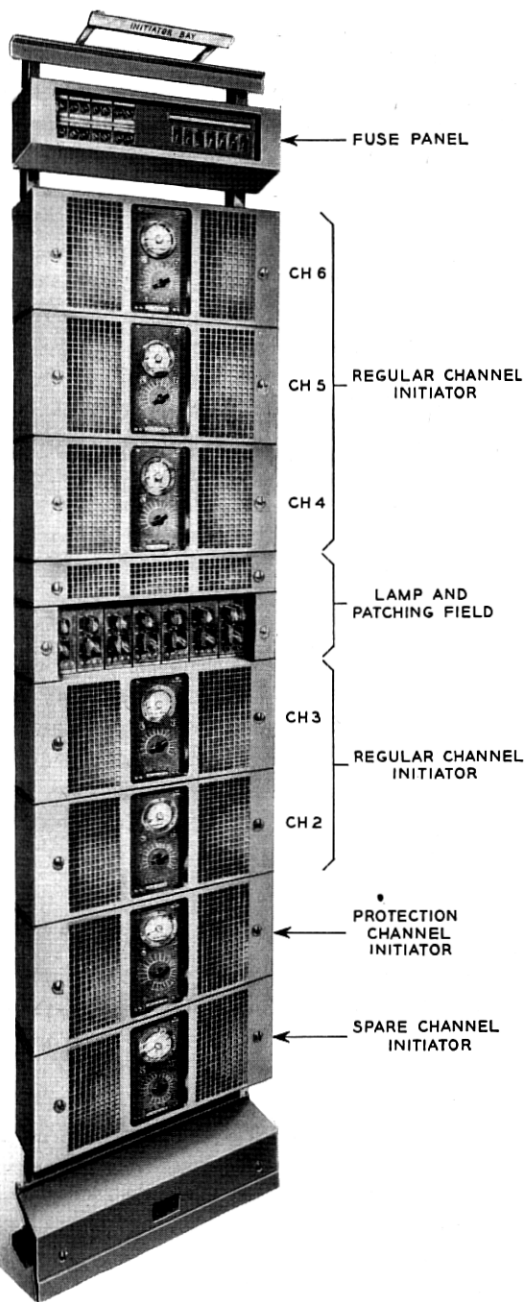

Fig. 14 — Initiator bay.

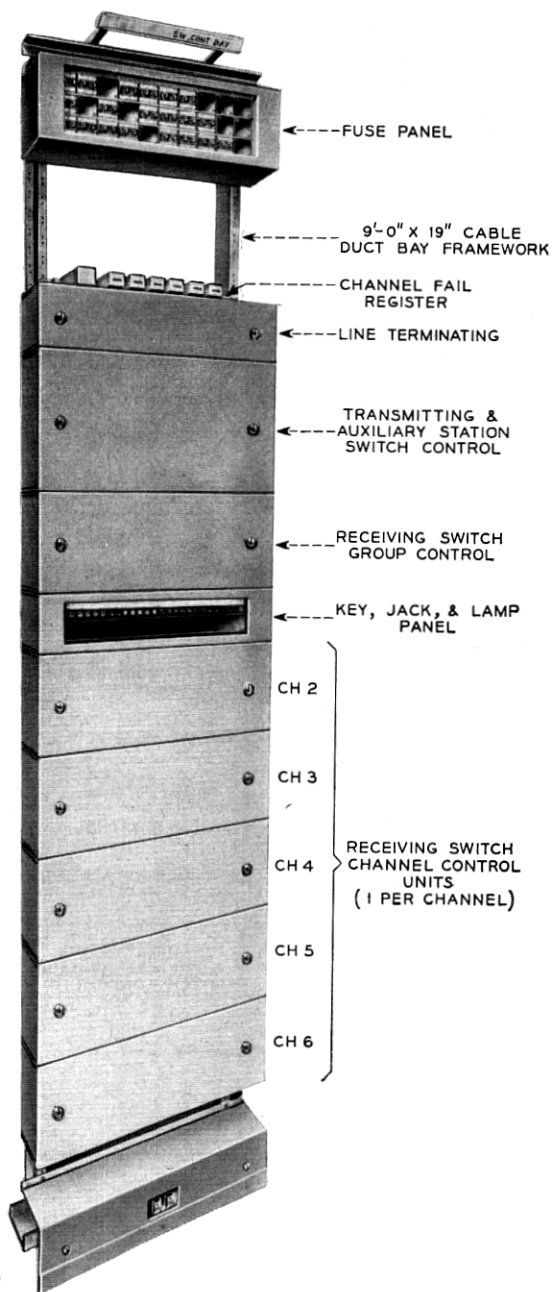

Fig. 15 — Switching control bay.

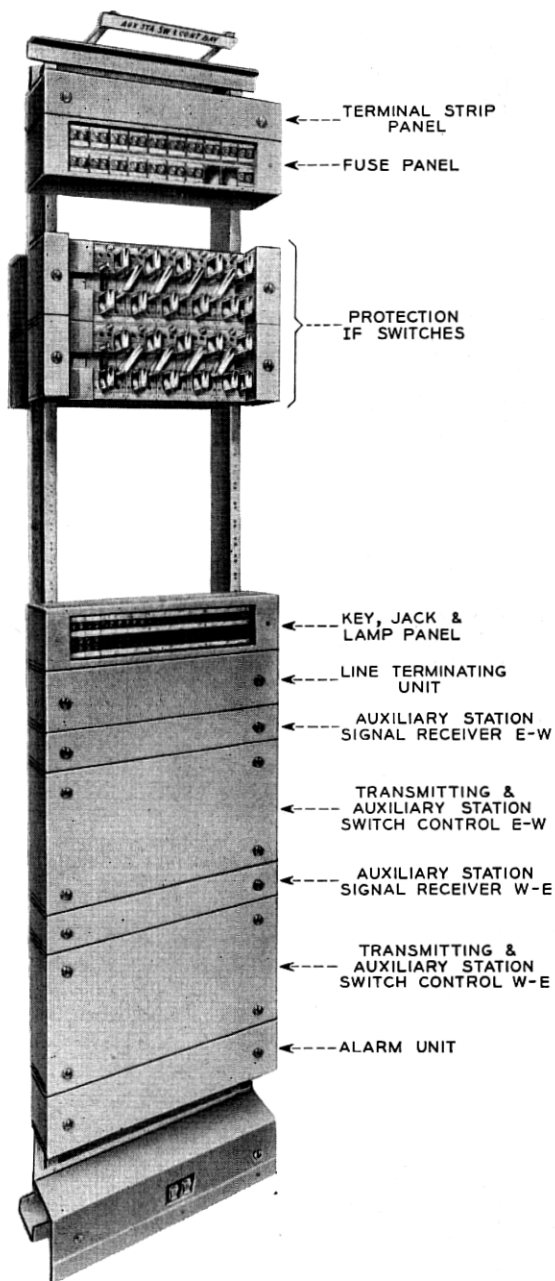

Fig. 16 — Auxiliary station switching and control bay.

channels at the receiving end of a switching section. This unit receives information from the regular channel initiators and sends out the identifying channel tones.

3. One *transmitting and auxiliary station switching control unit* which provides basic control equipment for the regular channels at the transmitting end of a switching section. This unit receives and amplifies the identification and guard tones.

4. One *channel detector unit* which provides the filtering and detectors for the channel identification signals.

5. One *line terminating unit* required for the line facilities over which the VF signals are sent.

6. *Key, jack and lamp panel*. This panel provides a mounting for various indicating lamps, line terminating test jacks, order wire jacks and a 24-volt test battery jack for checking relay equipment.

7. *Channel failure registers*. This unit provides arrangements to count the number of times that the protection channel transmission falls below the allowable minimum and also to count the number of times the protection channel is substituted for each of the regular channels.

Auxiliary Station Switching and Control Bay

The auxiliary station switching and control bay, Fig. 16, provides the equipment required for customer drop protection at auxiliary stations. The equipment mounted in the bay is as follows:

1. The *IF switches* which transfer the customer drop from the regular channel to the protection channel.

2. A *transmitting and auxiliary station switching control unit and channel detector units* discussed above in Items (3) and (4) of the switching control bay.

3. An *auxiliary station signal receiver unit* for each direction to receive the 2,100-cycle signal sent from the receiving station.

4. An *alarm unit* with arrangements for either remote or local operation.

5. A *key, jack and lamp panel* to mount the various alarm lamps, keys, test jack, order wire jacks and a 24-volt test battery jack for relay testing.

6. A *line terminating unit* to terminate the VF line between the backbone circuit and the auxiliary stations over which the signals to control the switch are sent.

PROGRAM SWITCHING

We have so far described the operation of automatic switching and the circuits used to provide automatic protection. In a system such as the

TD-2 where a large number of broadcasters are provided with TV service, a manual switching arrangement is necessary and program switching performs this function.

In transmitting TV a great deal of flexibility is needed to meet the needs of service. A few examples of when such flexibility is desirable are when the protection channel is used for service other than automatic switching or when a particular program must be transmitted over a number of channels simultaneously.

Program switching is done outside the framework of automatic switching. Fig. 17 shows in block diagram form how program switching ties in with TD-2 and automatic switching.

To meet the great variety of situations which arise program switching has to be engineered to meet the needs of each office individually. In order to have the necessary versatility this system has been designed around three basic circuits shown in Fig. 18. These are:

- Through channel group.
- Bridging amplifier group.
- Switch group.

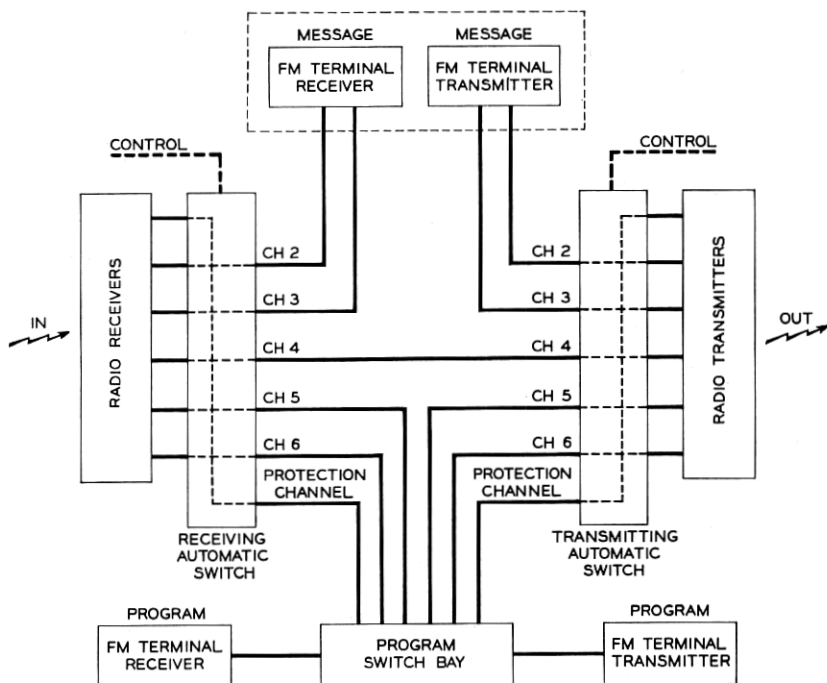

Fig. 17 — TD-2 radio automatic and IF program switching systems.

The thru channel group shown schematically in Fig. 18 provides a passive circuit for through transmission; an outlet for connection to branch circuits and a switch which can break the through path and feed the outgoing channel with a local signal.

The bridging amplifier group contains one or more bridging amplifiers. The number of outputs available is one greater than the number of amplifiers in the group.

The switch group operates to connect any one of a number of inputs to any one output or it may connect any single input to any one of a number of outputs.

With these three units the desired flexibility of program switching can be achieved. An example of how they may be used in combination is shown in Fig. 19 which shows a simple example of program switching. In actual offices where there may be four directions of transmission as well

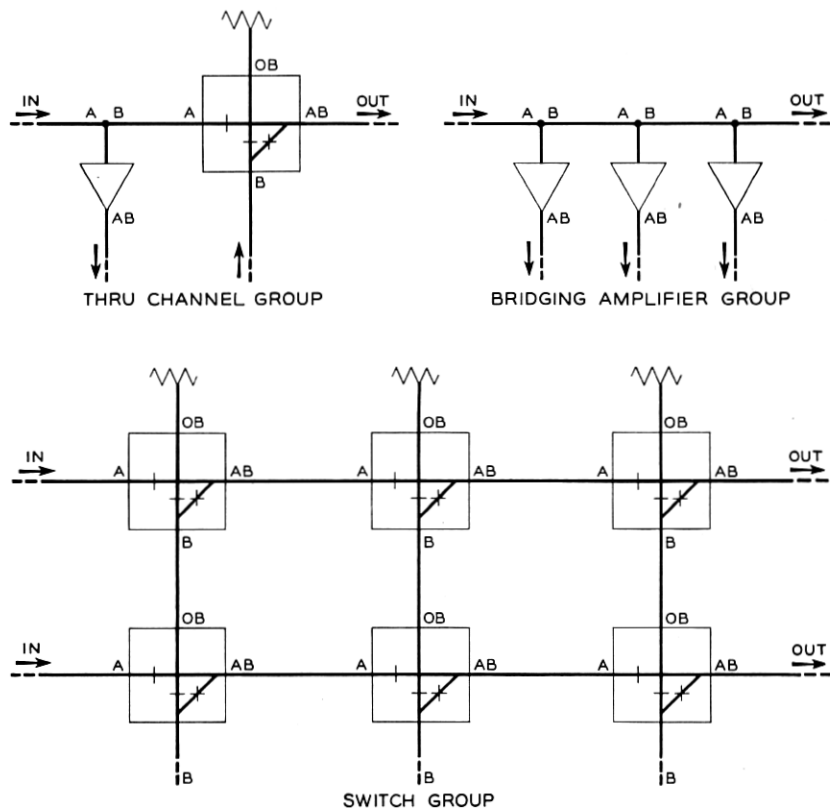

Fig. 18 — Basic circuits for program switching.

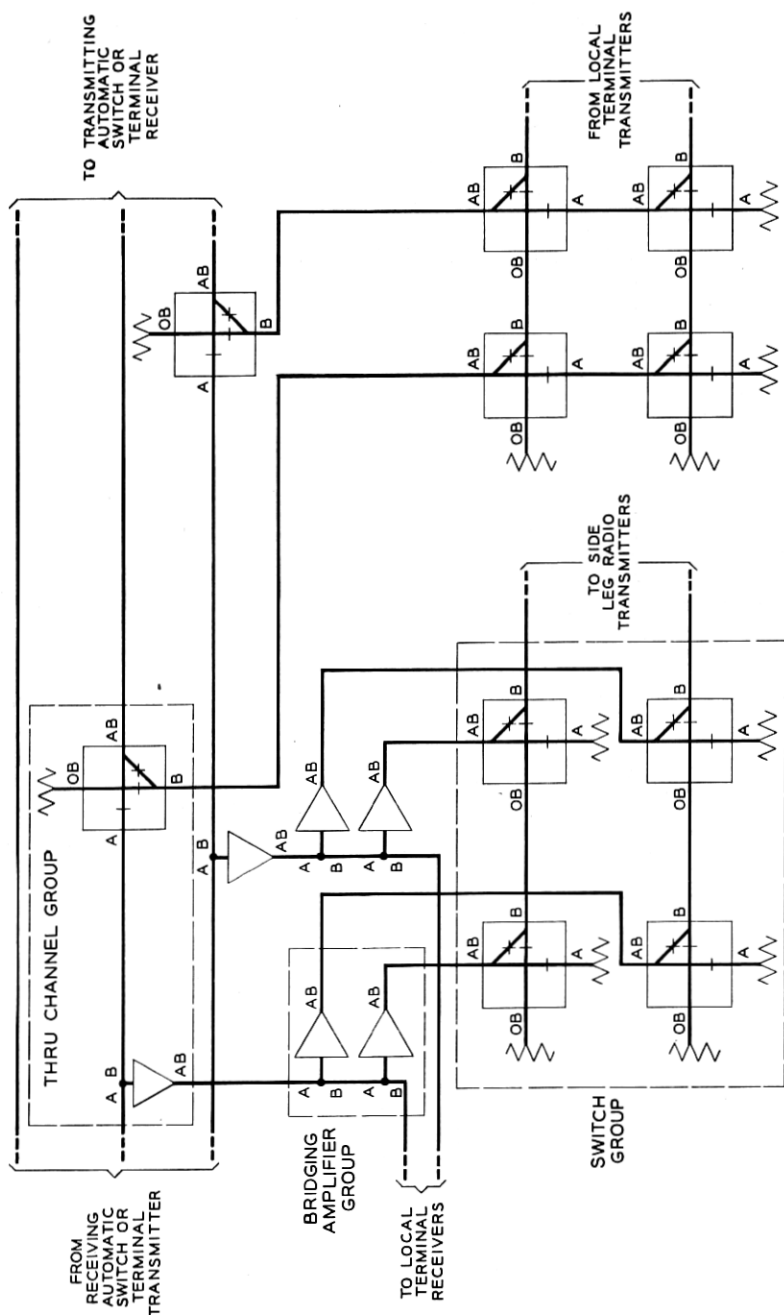

Fig. 19 — Example of program switching.

as a number of drops and pick-ups the circuits become much more intricate.

The operation of these switches can be performed locally by push buttons or from remote locations.

CONCLUSION

The TD-2 automatic protection switching system has been in service between Denver and Sacramento since mid-June 1954. Its performance has been followed closely by special evaluation test equipment installed at each switching station to record on message registers:

1. The number of channel initiator requests.
2. The number of seconds of channel initiator requests.
3. The number of switches made in each channel.
4. The number of seconds that switches are made in each channel.
5. The number of trouble conditions in the protection channel and the number of seconds that trouble conditions persisted.

In addition strip-chart recorders record each operation of each channel initiator and each switch, so that specific events can be analyzed in detail. This equipment does not evaluate the ability of the channel initiators to detect trouble conditions, but observations of message and television circuit performance have indicated that they are performing in the manner intended.

This system comprises 33 repeater sections arranged in three switching sections of 15, 7 and 11 repeater sections and has six westbound and five eastbound radio channels. It traverses difficult terrain, with many of the stations on mountain top locations, so that the outage time per equipment trouble is higher than in other parts of the country. There is, however, comparatively little fading in this area, probably because of the low moisture content of the air.

In the month of August, 1954, a typical month, switches were requested for 117,357 seconds, and 94.8 per cent of this time resulted in a switch. Of the 6,116 seconds of time requested but not switched, 1,974 seconds were not switched because the protection channel was in use by another channel, and the remainder were not switched because of other reasons including protection channel trouble.

These tests, together with service observations, lead to the conclusion that the Automatic Protection Switching System is effecting a substantial and satisfactory improvement in the reliability of TD-2 radio systems. Accordingly, the switching system is being installed on most of the important back-bone TD-2 routes.

APPENDIX I

The probability of interruption of a regular radio channel because of equipment failure is derived below. Regular channels are those used for telephone or television business; the protection channel is reserved for use instead of any regular channel which has failed or faded. Fading is considered separately from equipment failures.

We will consider a long radio system divided into switching sections of n repeater sections each. In practice the number of repeater sections per switching section will vary according to the geography of the route, but the argument below is easily extended to this situation. We will consider that there are N regular channels and one protection channel, and thus the total number of radio channels is $N + 1$.

1. Probability that a one-way repeater will be in a failed condition (i.e., the time that it is out of service in a year divided by the total time in a year) = p .

2. Probability that a specific one-way channel will be in a failed condition in a switching section of n repeaters very closely = np .*

3. Probability that a specific one-way channel and its protection channel both will be in a failed condition within a switching section of n repeaters (i.e., the time that both are out of service simultaneously divided by total time) very closely = $(np)^2$.

4. Probability that any specific one-way regular channel and some one of the other regular channels will be in a failed condition within a switching section of n repeaters very closely = $(N - 1)(np)^2$ where N is the number of regular channels.

5. But one of the two failures predicted in (4) will be made good by the protection channel, and therefore the probability that a specific one-way channel will be interrupted because of any one of the other regular channels has failed very closely = $\frac{1}{2}(N - 1)(np)^2$.

6. Then from (3) and (5) the probability that any specific one-way channel will be interrupted because of failure of any two channels very closely

$$= (np)^2 + \frac{(N - 1)(np)^2}{2} = \frac{(N + 1)(np)^2}{2}.$$

* More rigorously this probability

$$\begin{aligned} &= 1 - (1 - p)^n = 1 - (1 - np + \frac{n(n - 1)}{2} p^2 - \dots) \\ &= np - \frac{n(n - 1)}{2} p^2 + \dots \end{aligned}$$

where the terms subsequent to np represent the probability that the channel will be interrupted because more than one repeater has failed in the same channel in the same switching section. Since p is small, these terms can be neglected. The same argument applies to the discussion as devoted by the words "very closely."

7. Since p is small, the probability of three or more failures is very small and can be ignored.

8. Then the improvement in reliability of a one-way channel effected by automatic switching is the ratio of the probability of interruption without automatic switching to the probability of interruption with automatic switching and very closely

$$= \frac{2np}{(N+1)(np)^2} = \frac{2}{(N+1)np}$$

9. If a system is made up of R repeaters divided into switching sections of n repeaters, the probability that any specific one-way channel will be interrupted somewhere in the system because of failure of any two channels in any switching section very closely

$$= \frac{R}{n} \frac{(N+1)}{2} (np)^2 = R \frac{(N+1)}{2} np^2$$

(This neglects a small probability of simultaneous failure in more than one switching section of the system.)

10. The improvement effected by automatic switching in the reliability of a one-way channel then very closely

$$= \frac{2Rp}{R(N+1)np^2} = \frac{2}{(N+1)np}$$

which is the same as (8) above.

11. Telephone circuits comprise two directions of transmission, and interruption to either direction of transmission disrupts the circuit, so that for telephone the probability of interruption must be multiplied by two and the improvement divided by two.

APPENDIX II

The output signal of a TD-2 terminal transmitter when modulated by protection pilot is:

$$\begin{aligned} E_{\text{out}} = & J_0(x) \sin \omega_0 t + J_1(x) [\sin (\omega_0 + \omega_p)t - \sin (\omega_0 - \omega_p)t] \\ & + J_2(x) [\sin (\omega_0 + 2\omega_p)t + \sin (\omega_0 - 2\omega_p)t] \\ & + \dots \end{aligned}$$

where: $J_n(x)$ are the Bessel Functions of the first kind

ω_0 = the carrier angular frequency ($2\pi \times 70 \times 10^6$)

ω_p = the protection pilot angular frequency

$$(2\pi \times 8.5 \times 10^6)$$

x = Index of modulation = $\frac{\Delta\omega}{\omega}$

Since x is small (approximately .1) only the carrier and first order sidebands are necessary and $J_0(x)$ and $J_1(x)$ can be replaced by 1 and $x/2$ respectively. Therefore:

$$E_{\text{out}} = \sin \omega_0 t + \frac{x}{2} [\sin (\omega_0 + \omega) t - \sin (\omega_0 - \omega) t]$$

$$E_{\text{out}} = \sin \omega_0 t + x \cos \omega_0 t \sin \omega t$$

To a first approximation a signal of this form can be generated by adding two tones and using only the phase of the resultant. A requirement that one tone must be much larger than the other must also be met. As our tones we will take an output of the form:

$$\begin{aligned} E_{\text{out}} &= a_1 \sin \omega_0 t + a_2 \sin (\omega_0 - \omega_p) t \\ &= A \sin (\omega_0 t - \varphi) \end{aligned}$$

where

$$A = \sqrt{a_1^2 + a_2^2 + 2a_1 a_2 \cos \omega_p t}$$

and

$$\varphi = \tan^{-1} \left(\frac{a_2 \sin \omega_p t}{a_1 + a_2 \cos \omega_p t} \right)$$

We now impose the restriction that $a_1 \gg a_2$. Therefore we can approximate φ with:

$$\varphi \approx \frac{a_2}{a_1} \sin \omega_p t$$

The sum of the two tones is then:

$$E_{\text{out}} = A \sin \left(\omega_0 t + \frac{a_2}{a_1} \sin \omega_p t \right)$$

$$E_{\text{out}} \approx A \left[\sin \omega_0 t \cos \left(\frac{a_2}{a_1} \sin \omega_p t \right) + \cos \omega_0 t \sin \left(\frac{a_2}{a_1} \sin \omega_p t \right) \right]$$

Using again the fact that $a_2/a_1 \ll 1$

$$E_{\text{out}} \approx A \left[\sin \omega_0 t + \frac{a_2}{a_1} \cos \omega_0 t \sin \omega_p t \right]$$

When this wave is passed through a limiter, the amplitude variation is removed. We can thus generate an FM signal by adding a pair of tones — a high level 70-mc and a low level 61.5-mc tone. The difference in level of these tones determines the equivalent index of modulation.

REFERENCES

1. A. A. Roetken, K. D. Smith and R. W. Friis, The TD-2 Microwave Radio Relay System, B. S. T. J., **30**, Oct. 1951.
2. A. B. Crawford and W. C. Jakes, Jr., Selective Fading of Microwaves, B. S. T. J., **31**, Jan., 1952.
3. R. L. Kaylor, A Statistical Study of Selective Fading of Super-High Frequency Radio Signals. B. S. T. J., **32**, Sept., 1953.