

# Arcing of Electrical Contacts in Telephone Switching Circuits

## Part I—Theory of the Initiation of the Short Arc

By M. M. ATALLA

(Manuscript received April 1, 1953)

*This is a presentation of a theory for the mechanism of the initiation of the short arc commonly observed on the closure and opening of electrical contacts. The theory is based on the experimental evidence that an established arc is generally preceded by a period of local high frequency discharges at the contacts. During this period the circuit current builds up. If and when this current reaches the arc initiation current of the contact a steady arc is established. It is shown that this initiation period of the arc is directly determinable from the circuit conditions and the contact condition. This mechanism furnishes rather simple explanations to some complex phenomena commonly observed before the establishment of the arc. The mechanism of the initiation of an individual discharge, however, still remains uncertain.*

### INTRODUCTION

In the course of study of arcing phenomena between electrical contacts, it has been long established that a condition for sustaining the short arc is to maintain a current through the arc greater than a minimum value called the minimum arcing current. This current is generally a characteristic of the contact material and is appreciably affected by surface contaminations. For clean metals the minimum arcing current is usually equal to a few tenths of an ampere. Before establishing the arc, therefore, there must exist a certain mechanism which accounts for a rapid current build-up from zero to a value as high as the minimum arcing current. For an inductive circuit, a higher inductance should result in a longer period of current build-up. With a sufficiently high circuit inductance this initiation period may be made long enough to be directly observed and to allow an examination of the mechanism involved. Such experiments have been made and observations have indicated that the initiation period consisted of a succession of rapid dis-

charges at the contacts from the open circuit voltage to a lower voltage. During this process the current in the circuit built up in a discontinuous fashion and the steady arc was established only when the circuit current reached the minimum arcing current of the contact.

In this paper is presented our study of this initiation period. The following are the main objectives: (1) to establish the analytic relations governing the performance of a few simple contact circuits during the arc initiation period; (2) to check the analysis by direct measurements; (3) to apply the theory to explain a few arcing phenomena and empirical relations previously reported; and (4) to shed some light on the nature of the rapid local discharges at the contacts and the characteristics of the influential circuitry at the immediate neighborhood of the contact.

## NOTATION

$C$	Main circuit capacitance
$I$	Circuit current
$I_i$	Arc initiation current
$I_m$	Arc termination current or minimum arcing current
$L$	Circuit inductance
$(L)_{Limit}$	Limiting or maximum inductance above which a steady arc cannot be established
$R$	Circuit resistance
$V$	Voltage
$V_0$	Initial voltage
$V_{CT}$	Main condenser terminal voltage
$c$	Local capacitance at the contacts
$\ell$	Local inductance at the contacts
$n$	Number of discharges at the contacts
$r$	Local resistance at the contacts
$t$	Time
$v$	Voltage across a steady short arc
$\bar{v}$	Voltage across the contacts at the termination of a single local discharge
$z$	Local impedance at the contacts $\left[ \frac{\ell}{c} \right]^{1/2}$
$\alpha$	Ratio of capacitances $c/C$
$\omega$	Angular frequency $(Lc)^{-1/2}$

## ANALYSIS

In this section a few simple contact circuits are considered. In each case relations are derived for the current and voltage changes in the

circuit during the period of rapid discharges at the contacts preceding the steady arc. The analysis is based on the following simplified model of the mechanism involved: (1) The first local discharge at the contact takes place when the proper separation corresponding to the initial voltage  $V_0$  is reached; (2) this discharge time is assumed to be short and negligible in comparison to the following charging time; (3) the local capacitances at the contact recharge from the main circuit until the same initial voltage  $V_0$  is reached when a second discharge takes place; (4) this process repeats until a steady arc is established provided that the circuit is capable of building up enough current, — otherwise, the local discharges will continue and finally stop when the main circuit becomes incapable of charging the local contact capacitances to  $V_0$ ; and (5) all the local discharges at the contact are terminated at a constant voltage  $\bar{v}$  for any one set of circuit conditions. The nature of  $\bar{v}$  is left to be determined and physically understood from our measurements.

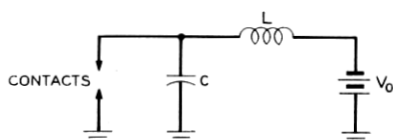

Fig. 1 — Typical battery-inductance-contacts circuit.

*Battery  $V_0$ ,  $L$  and Contacts, Fig. 1*

Following the first discharge at the contact from  $V_0$  to  $\bar{v}$  the local contact capacitances will recharge with a current

$$I = (V_0 - \bar{v}) \left( \frac{c}{L} \right)^{1/2} \sin \omega t,$$

where  $\omega = (Lc)^{-1/2}$ .

The voltage at the contact will reach  $V_0$  at  $t_1 = \pi/2\omega$  and the corresponding current is

$$I_1 = (V_0 - \bar{v}) \left( \frac{c}{L} \right)^{1/2}.$$

A second discharge will then take place and recharging will proceed with the new boundary conditions: at  $t = 0$ , the contact voltage is  $\bar{v}$  and the circuit current is  $I_1$ . By following this procedure, a general expression for the  $n$ th charging process is obtained:

$$I(n) = (V_0 - \bar{v}) \left( \frac{c}{L} \right)^{1/2} (n)^{1/2} \quad (\mathbf{a})$$

and

$$\omega \cdot t(n) = \cot^{-1} (n - 1)^{1/2} \quad (1)^*$$

The relation between the number of discharges  $n$  and time  $t$  is given by

$$t = \frac{1}{\omega} \sum_{n=1}^{n=n} \cot^{-1} (n - 1)^{1/2}.$$

Only an empirical expression for this summation was obtained with a maximum error less than 10 per cent:

$$t = \frac{\pi}{2\omega} (n)^{1/2}.$$

The current build-up in the circuit is, therefore, expressed as a function of time by the following relation:

$$I(t) = \frac{2}{\pi L} (V_0 - \bar{v})t \quad (2)$$

In other words, the current is independent of the contact capacitances and increases linearly with time at a rate inversely proportional to the circuit inductance.† As soon as the circuit current reaches the arc initiation current  $I_i$ , a steady arc is established. The initiation time of the steady arc is therefore given by:

$$t_i = \frac{\pi}{2} \cdot \frac{I_i L}{V_0 - \bar{v}} \quad (3)$$

For  $I_i = 0.5$  ampere,  $L = 10^{-6}$  henry and  $V_0 - \bar{v} = 30$  volts,  $t_i = 2.6 \times 10^{-8}$  second.

### *C, L and Contact, Fig. 2*

If the battery is replaced by a condenser  $C$  where the ratio  $\alpha = c/C$  is much less than 1.0 an analysis similar to the above can be made. In

\* The assumption that all discharges will take place from the same voltage  $V_0$  is only true if: the motion of the contact is negligibly small, the discharges do not change the contact geometry to the extent of materially changing the contact separation, and if the effect of the residual ions is negligible.

† This is only true if the circuit resistance is zero. For a finite circuit resistance  $R$ , and  $\frac{R}{2} \left(\frac{c}{L}\right)^{1/2}$  much less than 1.0, it can be shown that the current approaches the asymptotic value  $\frac{V_0 - \bar{v}}{2R}$ .

‡ It is shown later by measurement, that the initiation current  $I_i$  is essentially the same as the arc terminating current  $I_m$ .

this case, however, in setting the boundary conditions one must consider the drop in voltage across the main condenser during the previous charging processes. The following are the resulting expressions for the circuit current, main condenser voltage and the charging time, all as functions of  $n$ :

$$I(n) = \frac{V_0 - \bar{v}}{L\omega} \cdot \left[ n(1 - \alpha(n - 1 + \alpha n)) \right]^{1/2} \quad (4a)$$

$$V(n) = V_0 - \alpha n(V_0 - \bar{v}) \quad (4b)$$

$$\omega \cdot t(n) = \sin^{-1} \alpha \left[ \frac{n}{1 - \alpha(n - 1)} \right]^{1/2} + \tan^{-1} \left[ \frac{1 - \alpha(n - 1)}{(1 + \alpha)(n - 1)} \right]^{1/2} \quad (4c)$$

Only an empirical expression for the summation

$$\sum_{n=1}^{n=1} t(n)$$

was obtained with an error less than 10 per cent

$$\sum_{n=1}^{n=n} \omega \cdot t(n) = \frac{\pi}{2} (n)^{1/2} (1 + \alpha n).$$

The current relation indicates that the current increases from zero at  $n = 0$  to a maximum current

$$I_{\max} = \frac{V_0 - \bar{v}}{2} \left( \frac{C}{L} \right)^{1/2}$$

at  $\alpha n = 1/2$  then drops back to zero at  $n\alpha = 1.0$  when the discharges are terminated. The total discharge time is approximately  $\pi(LC)^{1/2}$  and the terminal voltage on the main condenser is  $V_{CT} = \bar{v}$ . If during the process of current build-up the current reaches a value equal to the arc initiation current a steady arc is established. It is evident that a steady arc cannot be established if the maximum current attainable during the discharges is less than the arc initiation current. This leads to the concepts of a limiting inductance and limiting voltage in a circuit that can allow the establishment of a steady arc.<sup>1</sup> The limiting inductance is

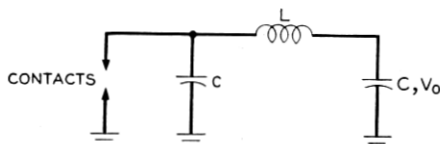

Fig. 2 — Typical condenser-inductance-contacts circuit.

<sup>1</sup> L. H. Germer, Arcing at Electrical Contacts on Closure, Part I, J. Appl. Phys. 22, p. 955, 1951.

defined as the largest inductance for a given circuit above which a steady arc cannot be obtained and the limiting voltage is defined as the lowest voltage for a given circuit below which a steady arc cannot be obtained:

$$(L)_{\text{Limit}} = \frac{C}{4} \cdot \left( \frac{V_0 - \bar{v}}{I_i} \right)^2 \quad (5a)$$

$$(V_0 - \bar{v})_{\text{Limit}} = 2I_i \left( \frac{L}{C} \right)^{1/2} \quad (5b)$$

The assumption made that all charging processes are much longer in time than the discharging times, imposes a limitation on the applicability of the above relations. Equation 4c can show that the minimum charging time is  $(2/\omega)\alpha^{1/2}$ . The accuracy of the above relations is better the larger this time is compared to the discharge time of the local contact capacitance. Assuming distributed characteristics for the local and relatively small contact circuitry\* the discharge time is  $2(\ell c)^{1/2}$ . The limitation involved, therefore, is that  $(2/\omega)\alpha^{1/2}$  must be greater than  $2(\ell c)^{1/2}$  or  $L/C > \ell/c$ . In other words, the impedance of the main circuit must be greater than the impedance of the local circuit at the contact.

#### MEASUREMENTS

All the measurements presented were obtained from an inductive type circuit, *C-L-Contact*. The main circuit, Fig. 3, consisted of a condenser *C* in series with a honeycomb inductance which is connected by a short lead, about 2 cms, to a pair of clean palladium contacts operating in laboratory air. The contacts were mounted on a cantilever bar arrangement, described by Pearson<sup>2</sup>, which allows fine adjustments of the separation between the contacts as well as slow motion of the contacts to avoid physical closure before the end of a transient.

Three sets of measurements were made.

(1) Contacts voltage measurements: the transients obtained usually needed some correction to compensate for the effects of the measuring oscilloscope circuit. None of these measurements are presented in this paper. It may be mentioned, however, that they indicated the existence of rapid discharges at the contacts preceding the establishment of the steady arc.

(2) Circuit current measurements, Fig. 3 (a): these were made by

\* In a later section of this paper, measurements were shown to indicate the plausibility of this assumption.

<sup>2</sup> G. L. Pearson, Phys. Rev. **56**, p. 471, 1939.

measuring the voltage change across a 10-ohm non-inductive resistor inserted between the main circuit condenser and ground.

(3) Main condenser voltage measurements, Fig. 3(b): the oscilloscope plates were shunted by an  $1100 \times 10^{-12}$  farad capacitor and the combination was used as the main circuit condenser. The above sets of measurements 1 and 2 furnished the data necessary for a quantitative establishment of the theory. It is evident that the measuring scope circuits did not interfere with the normal behavior of the contact circuit.

#### *Development of Circuit Current During Arc Initiation Period*

The circuit in Fig. 3(a) was used. The contact separation was gradually decreased until the discharges started and the resulting current transients were recorded. The circuit parameters were chosen such that, according to Equation 3 of our analytical results, the initiation time was of the order of microseconds. Fig. 4(A) shows a typical current-time transient where a steady arc was established. The circuit had  $L = 1100 \times 10^{-6}$  henry and  $C = 10^{-6}$  farad. The current started from zero and increased during the multiple discharge period until point 1 where the current was 0.2 ampere and a sustained arc was established. The current then increased to a maximum of 1.7 amperes then dropped. At point 3 the arc stopped when the current was 0.24 ampere. In Fig. 4(B) the first

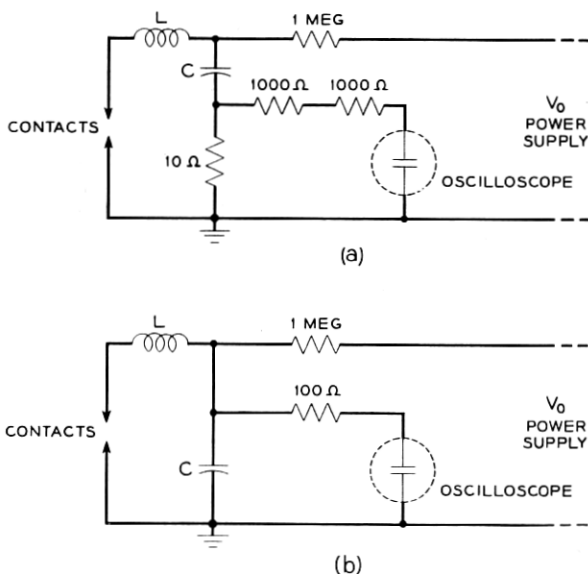

Fig. 3 — (a) Contacts circuit and circuit current measuring circuit. (b) Contacts circuit and main condenser voltage measuring circuit.

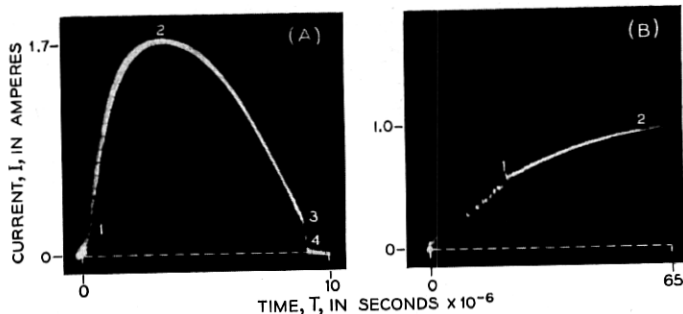

Fig. 4 — Circuit current transients with steady arc established.

portion of a similar transient is shown:  $L = 5100 \times 10^{-6}$  henry and  $C = 10^{-6}$  farad. The current build-up during the multiple discharge period is shown as an interrupted line 0-1. The steady arc was established at 0.57 ampere.

From a group of similar transients, pairs of measurements were made of the initiating current and terminating current of the steady arc. The results are given in Table I. It is concluded from the results that *the initiating current and terminating current of an arc are the same.*

The high-frequency discharges at the contact do not necessarily have to be followed by a sustained arc. *A sustained arc is only obtained if the maximum current established during the local discharges at the contact is equal to or greater than the arc initiation current.* Fig. 5 (A) shows a current-time transient without an initiation of the steady arc:  $V_0 = 400$  volts,  $L = 5100 \times 10^{-6}$  henry and  $C = 1100 \times 10^{-12}$  farad. The maximum current reached was only 0.13 ampere which was not sufficient for initiating a steady arc. It is of interest to notice that the oscillations superimposed on the zero current line following the transient can allow a calculation of the local capacitances at the contact. Such a calculation gave  $c = 7.8 \times 10^{-12}$  farad. Fig. 5 (B) shows a similar transient for the same circuit with  $V_0 = 500$  volts. Following the first current build-up and drop, 1-2-3, the main condenser had a residual negative voltage high enough to produce a reversed current build-up and drop, 3-4-5.

#### *Voltage Drop in Main Condenser During Arc Initiation Period*

During the period of rapid discharges the current build-up in the circuit is accompanied by a voltage drop at the main condenser. This drop may correspond to one of two phenomena at the contact: (1) multiple discharges leading to a steady arc, and (2) multiple discharges without steady arc, followed by an open circuit. Fig. 6 and 7 are re-



TABLE I — ARC INITIATION AND ARC TERMINATION CURRENTS  
 PALLADIUM CONTACTS IN AIR\*

Arc Initiation Current $I_i$ : Amps.	0.12	0.21	0.21	0.15	0.25	0.19	0.23	0.40	0.65	0.61	0.57	0.52	0.45
Arc Termination Current $I_m$ : Amps.	0.13	0.16	0.17	0.20	0.22	0.24	0.24	0.42	0.50	0.52	0.53	0.58	0.59

\* Both numbers given in one column were obtained from the same transient.

spective records of the voltage change at the main condenser. Fig. 6 (A) corresponds to the case where the multiple discharge period was short and lead to a steady arc. During this arc the main condenser voltage dropped from point 1 to point 2 when the arc was arrested. This was followed by striking a second arc in the opposite direction which lasted until point 3. Line 3-4 represented the recharging of the main condenser from the power supply circuit. Superimposed on the same figure is the trace 1-2-3-5 corresponding to a closure at the contact instead of an open circuit. While line 1-2-3 shows two consecutive arcs, it is generally possible to obtain any number of such arcs. An even number of arcs will result in a *positive* residual voltage at the main condenser, Fig. 6 (A) while an odd number of arcs will result in a *negative* residual voltage at the main condenser, Fig. 6 (B).

Figs. 7 (A) and 7 (B) correspond to the case when the multiple discharges did not lead to a steady arc due to insufficient current build-up. The multiple discharges caused a voltage drop 1-2 across the main condenser followed by an open circuit and recharging, 2-3.

#### Discharge of the Local Circuitry at the Contact

Fig. 8 (a) represents a plausible representation of the local circuitry at the contact. When the conditions between the contacts are favorable

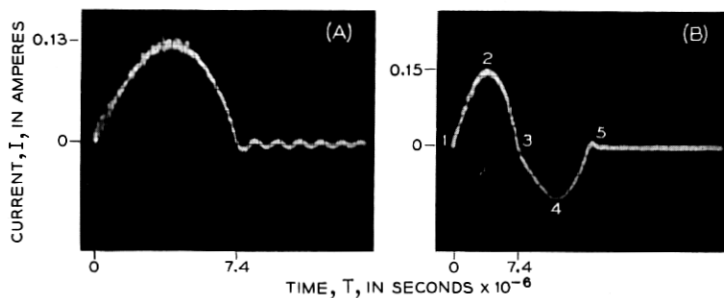

Fig. 5 — Circuit current transients without a steady arc.

for the initiation of the arc, a small local capacitance  $c'$  will furnish the necessary charge, through a small impedance  $z'$ , according to whatever mechanism that may be involved in the initiation process.\* The connection from the contact to the main circuit is represented by a short transmission line with the distributed characteristics,  $r$ ,  $\ell$  and  $c$ . The drop at the contact from the initial voltage  $V_0$  to the arc voltage  $v$  will cause a current surge  $(V_0 - v)(c/\ell)^{1/2}$ , if  $r$  is neglected, for a period  $2(\ell c)^{1/2}$  corresponding to the time required by the pulse to travel to the end of the line and return to the contact. At this time the arc is extinguished by the reflected pulse and the final voltage at the contact is  $-(V_0 - 2v)$ . Figs. 8(b) and 8(c) are diagrammatic representations of the process. For a purely inductive line, therefore, the contact voltage  $\bar{v}$  following one discharge is  $-(V_0 - 2v)$ . For a dissipative line, however,  $\bar{v}$  is algebraically greater. Equation 4 of Germer and Haworth<sup>3</sup> was derived to give the voltage following an arc for a similar circuit with lumped characteristics. For  $r/(\ell/c)^{1/2}$  less than 1.0 this equation can be

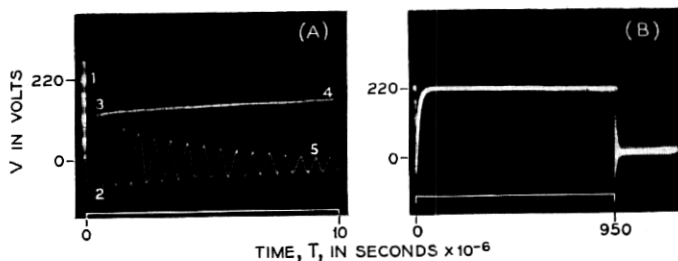

Fig. 6 — Voltage transients across main condenser with steady arc established.

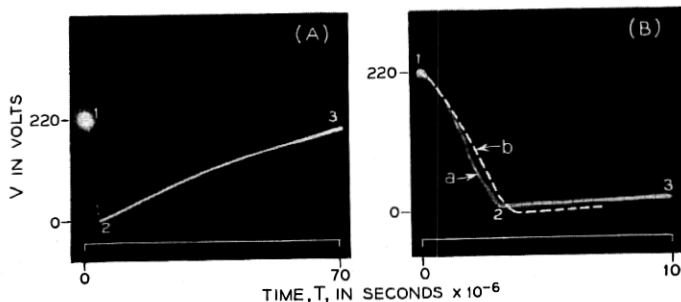

Fig. 7 — Voltage transients across main condenser without steady arc.

\* This mechanism is not clearly understood at the present time. It is the opinion of the writer, however, that the initiation time is only a few times the transit time of the metal ion under the prevailing conditions.

<sup>3</sup> L. H. Germer and F. E. Haworth, Erosion of Electrical Contacts on Make, *Appl. Phys.* **20**, p. 1085, 1948.

approximated by:

$$\bar{v} = 2v - V_0 + \frac{\pi}{2} \cdot \frac{r}{z} (V_0 - v) \quad (6)$$

where  $z = (\ell/c)^{1/2}$ .

Our measurements were then applied to demonstrate the plausibility of the above description of the local circuitry at the contact. This was done in the following fashion.  $\bar{v}$  was obtained by three methods. (1) Measurements were made of the multiple discharges preceding a steady arc, from records similar to Fig. 4(B), and  $\bar{v}$  was calculated from Equation 3, (2) measurements were made of the maximum current attainable during the multiple discharge period, from records similar to Fig. 5(A), and  $\bar{v}$  was calculated from the expression

$$I_{\max} = \frac{1}{2} (V_0 - \bar{v}) \left( \frac{C}{L} \right)^{1/2},$$

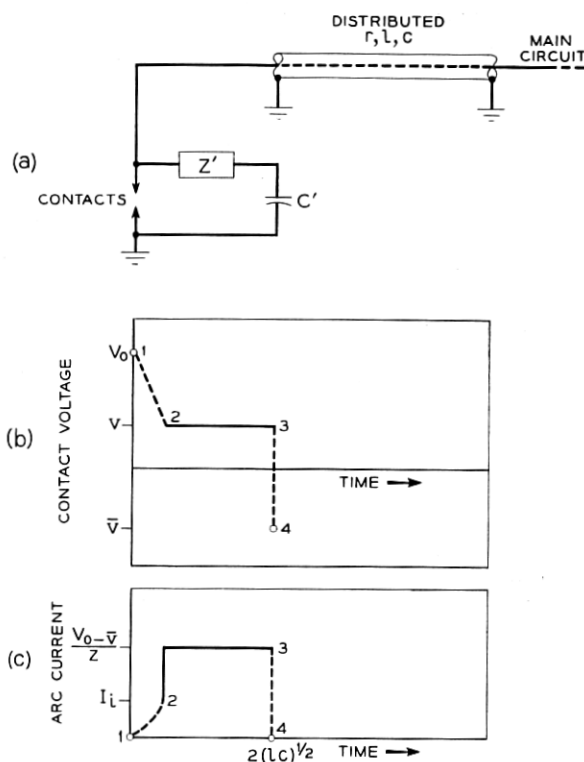

Fig. 8 — (a) Representation of local circuitry at contacts. (b) Voltage transient at contacts during one discharge of local circuitry. (c) Current transient at contacts during one discharge of local circuitry.

TABLE II — RATIO  $r/z$  FOR LOCAL CIRCUITRY AT CONTACTS

Initial Voltage $V_0$	100	150	200	230	250	300	360	400	460
$\frac{r}{z}$	0.56	0.65	0.55	0.41	0.55	0.30	0.40	0.40	0.48

and (3) measurements were made of the terminal voltage across the main condenser at the end of the multiple discharges, from records similar to Fig. 7, which, according to our analysis, is equal to  $\bar{v}$ . For these values of  $\bar{v}$  Equation 6 was used to compute  $r/z$ . The results are given in Table II. Each value of  $r/z$  in this table is the average of 3 to 6 values obtained by the different methods described above. In all cases  $r/z$  was between 0.4 and 0.7. This indicates that the local contact circuitry is oscillatory. For our circuit,  $c$  was measured at  $7.8 \times 10^{-12}$  farad and if  $\ell$  is assumed to be  $2 \times 10^{-8}$  henry, the computed resistance  $r$  is 20 to 35 ohms. This is about 500 times greater than the dc resistance of the same circuit. With this concept of the local contact circuitry  $\bar{v}$  was well defined and was then possible to perform some checks of the main analytical relations presented in this paper with new measurements and with measurements previously published.

#### *Comparison of Theory with Measurements:*

(1) Voltage drop across main condenser: In Fig. 7(B) is shown the voltage drop across the main circuit condenser as a function of time for  $L = 10^{-3}$  henry,  $C = 1100 \times 10^{-12}$  farad and  $V_0 = 220$  volts. Line (a) was measured and Line (b) was computed using Equation 4(b). The value of  $\bar{v}$  used was obtained from Equation 6. Good agreement is indicated.

(2) Limiting circuit conditions for obtaining a steady arc: It was pointed out in a previous section of this paper that a steady arc can be established only if the maximum current reached during the multiple discharge period is equal to or greater than the arc initiation current. Equations 5(a) and 5(b) are expressions for the limiting circuit inductance and the limiting initial voltage respectively. Equation 5(b) was used to compute the limiting voltage for a set of circuit conditions for which measurements were made and published, Reference 3. In Table IV Column 3 of this reference measured values of the limiting voltage  $V_0$  were presented. A comparison of measured and computed  $V_0$  are given here as Table III. It may be pointed out that the deviations between measurements and calculations are of the order of the measured

spread in the minimum arcing current as given in the same reference, Table V.

(3) Contact activation and limiting circuit conditions for arcing: In Reference 3, it was reported that the limiting inductance for active contacts was greater by more than 2 orders of magnitude than for clean contacts. By calculation, Equation 5(a),

$$[(L)_{\text{active}}/(L)_{\text{clean}}]_{\text{Limit}} = 600.$$

It was also reported that for  $C = 10^{-8}$  farad and  $V_0 = 50$  volts the limiting inductance observed for active silver was between  $10^{-3}$  and  $10^{-2}$  henry. By calculation, Equation 5(a), the limiting inductance for the same conditions is about  $4 \times 10^{-3}$  henry.

(4) Contact activation and arc initiation time: According to Equation 3 the initiation time of the steady arc is directly proportional to the arc initiation current. For the same circuit conditions, therefore, active contacts should have a shorter period of arc initiation. This result seems to contradict some published observations<sup>4</sup> where it was pointed out that the voltage drop into an arc was shorter for clean contacts than for activated contacts. A number of transients, furnished by the authors, were carefully examined. It was observed that in most cases

TABLE III — COMPUTED AND MEASURED LIMITING VOLTAGES FOR ESTABLISHING A STEADY ARC BETWEEN CLEAN SILVER CONTACTS\*

Observed ( $V_0$ ) Limit for first detectable arc	Computed ( $V_0$ ) Limit
50	49
66	102
220	211
38	38
85	75
206	153
31	28
64	52
200	102
24.5	23
60	40
30	20
13	16
11.5	14
13	13
25	17

\* A few observations were not included in this table. These correspond to the cases where the calculated initiation times of the arc were of the order or greater than the time of physical closure of the contacts. As expected, the observed voltages were consistently higher than the computed voltages.

<sup>4</sup> L. H. Germer and J. L. Smith, Arcing at Electrical Contacts on Closure, Part, III. J. Appl. Phys., **23**, p. 553, 1952.

for *both* active and clean contacts the transient started with a rapid drop. For clean contacts this drop was directly to the steady arc voltage of the contact metal. For active contacts the drop was to a higher voltage between 15 and 32 volts followed by a gradual and irregular drop in voltage. The time of the first rapid drop was invariably between  $2 \times 10^{-9}$  and  $4 \times 10^{-9}$  second for *both* clean and active contacts over a range of circuit inductances between  $0.1 \times 10^{-6}$  and  $48 \times 10^{-6}$  henry. This time was just about the time resolution of the scope used indicating that in all cases the initiation time was less than the time resolution of the scope. This was also borne out by our calculations, Equation 3, where the longest initiation time for the conditions studied was only  $1.2 \times 10^{-9}$  second. The higher arcing voltage of active contacts mentioned above has been previously reported in Reference 3. It was pointed out that active contacts have arc voltages comparable with those of carbon, 19 to 30 volts.\* The slow drop in voltage following the first rapid drop observed with active contacts is probably a burning off process of the activating substance on the contacts as indicated by a continuous approach of the arc voltage to that of the clean metal. It may be added that for cases where the initial circuit voltage is closer to the carbon arc voltage one should expect a smaller initial drop. This was confirmed by measurements made at 35 volts.

In connection with the experimental study of the initiation of the arc, the following concluding remark may be made. Unless the measuring apparatus has a response faster than the individual discharges at the contacts, the recorded transient will essentially be some particular average of a complex contacts transient. It should not, accordingly, be mistaken for the more fundamental and usually much faster formative transient of the arc.

The author is indebted to Dr. P. Kisliuk and Dr. L. H. Germer for much valuable discussion.

\* Recent measurements by the writer on arc lamp carbon have given arc voltages as high as 43 volts.