

The Correlatograph

A Machine for Continuous Display of Short Term Correlation

By W. R. BENNETT

(Manuscript received April 24, 1953)

An analog device has been constructed which displays short term correlation as a three-dimensional plot in which the rectangular coordinates are running time and lag time and the intensity of the pattern represents the correlation function. Preliminary tests on the properties of such a device are reported.

The place of the electrical spectrograph¹ as a signal analyzer has become well established in laboratory technology. It has occurred to many investigators however that the spectrum is not the only property of a signal which may be worthy of study, and in recent years there has been a considerable interest in other features, notably the correlation functions. On the basis of the accepted mathematical definitions the auto correlation function is the Fourier cosine transform of the power spectrum and in this sense would contain equivalent information presented in a different form. However, the mathematical definitions apply to a very long time interval and in practice we often deal with short segments of non-stationary processes. The spectrograph does not evaluate the true spectrum in such cases but gives instead a spectrum-like function of frequency which changes with the observation time. We may regard the resolving filter as performing a weighted analysis in which the most recent parts of the signal contribute most heavily to the instantaneous response. The resulting "short term" spectrum depends on the characteristics of the resolving filter as well as the signal, but over a useful range of filtering selectivity the individual peculiarities of the signal are distinguishable even though the structural background may be characteristic of the filter.

"Short term" correlation functions, in which the averaging interval is finite, have also been investigated and show phenomena analogous to

the short term spectrum. Comparison of the two short term functions is a much more involved matter than when the time interval is large in both cases. The subject has been extensively treated in the literature,² but the conclusions are still somewhat obscure. In an investigation which was started by the present author and the late Liss C. Peterson in 1950, we noted that a complete correlation analogue of the audio spectrograph had apparently never been constructed even though suggestions had appeared concerning the possibility.³ It seemed that some of the questions concerning the merits of the correlation method of analysis could not properly be answered without actually building and testing such a machine and it also appeared possible that we would thereby add another useful tool for the problems associated with speech and other signals of interest. We accordingly undertook the design and construction of a "correlatograph" following lines closely parallel to spectrographic experience in order to economize in new shop designs.

In a spectrograph, such as used in visible speech for example, a three-dimensional display is obtained in which time and frequency are two rectangular coordinates and the short term power spectrum is represented by the intensity of light or density of marking. The functional mechanism is illustrated in Fig. 1. The incoming signal is delivered to a bank of band pass filters with midband frequencies uniformly spaced throughout the frequency range of interest. The envelopes of the filter output waves are picked up in turn by a rotating switch arm to control the voltage impressed on a marking stylus. The stylus moves across the paper in synchronism with the collector arm and the paper advances after each stroke.

The analogous diagram for a correlatograph is shown in Fig. 2. We recall that the correlation of two functions is defined as the average of

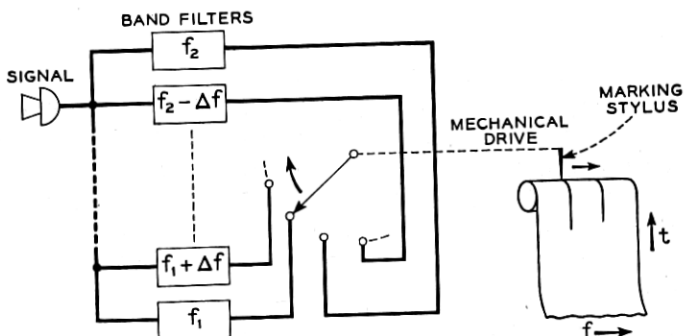

Fig. 1 — Mechanism of spectrograph.

their product with fixed time lag; i.e., when T is large, the expression

$$\psi_{12}(\tau) = \frac{1}{T} \int_0^T f_1(t)f_2(t - \tau) dt$$

gives the cross-correlation of $f_1(t)$ and $f_2(t)$, and the expression

$$\psi_{11}(\tau) = \frac{1}{T} \int_0^T f_1(t)f_1(t - \tau) dt$$

gives the autocorrelation of $f_1(t)$. In short term correlation T is finite. In Fig. 2, the different lag times are obtained by a tapped delay line and each tap is followed by its own multiplier and integrator. The integrated values are picked up by a rotating switch arm to control the marking stylus voltage as in Fig. 1. The rectangular coordinates are now t and τ instead of t and f . The marking intensity represents the correlation function.

In actual spectrographs it is usually found expedient to replace the bank of filters by a single filter and use a swept frequency oscillator and modulator to heterodyne the signal across the filter band. A rotating condenser plate tuning the oscillator thus takes the place of the rotating switch. The sweeping frequency must not change too rapidly for the analyzing filter to respond adequately, and also must not change so slowly that short signal bursts are imperfectly registered. A preliminary recording of the signal wave with a subsequent reproduction at a different

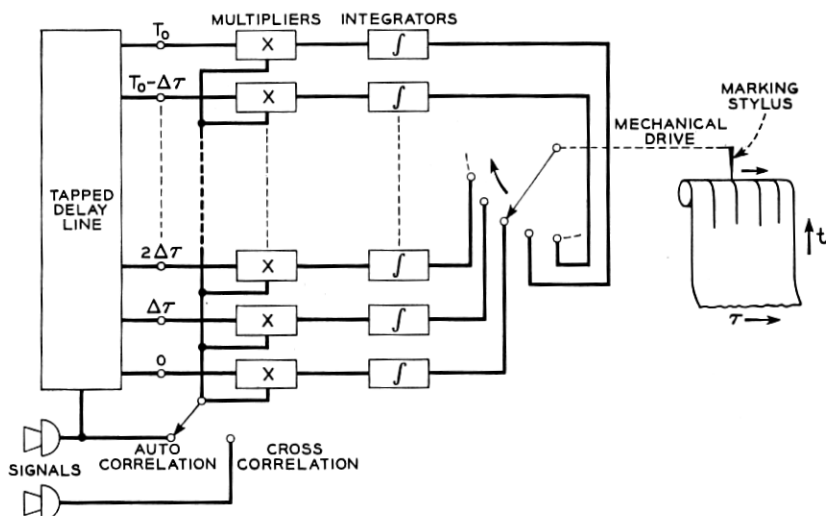

Fig. 2 — Mechanism of correlatograph.

speed forms a practical technique for securing the desired resolution in both frequency and time. Likewise in the correlatograph we can dispense with individual multipliers and integrators if we are willing to give up some of the otherwise available integration time for each τ value. One multiplier and one integrator are then put in series with the switch arm and the contacts go directly to the delay line taps as shown in Fig. 3. A complete analogy with the simplified spectrograph would require a line of variable delay with a single output tap. This could be done with magnetic recording and moving heads, thereby eliminating the rotating switch. We felt however, that the fixed delay line would furnish the more stable and accurate component and chose the arrangement of Fig. 3. An auxiliary recording and reproducing process made it possible to accommodate a wide variety of signals with the one delay line.

DETAILS OF APPARATUS

Fig. 4 shows the arrangement of apparatus chosen. Our program was aimed at signals such as might occur in a nominal speech band extending from 200 to 4,000 cps recorded on magnetic tape at 15 inches per second. The reproducing element was a spinning double-ended pickup coil which successively scanned a one-inch loop of tape with one end beginning its scan just as the other end left the tape. The coil made 60 revolutions per second and hence the reproducing speed was 120 inches per second or eight times the recording rate. Our speech band was thus made to occupy the range from 1,600 to 32,000 cps, and this was therefore the range chosen for the delay line. A recording speed other than 15 inches

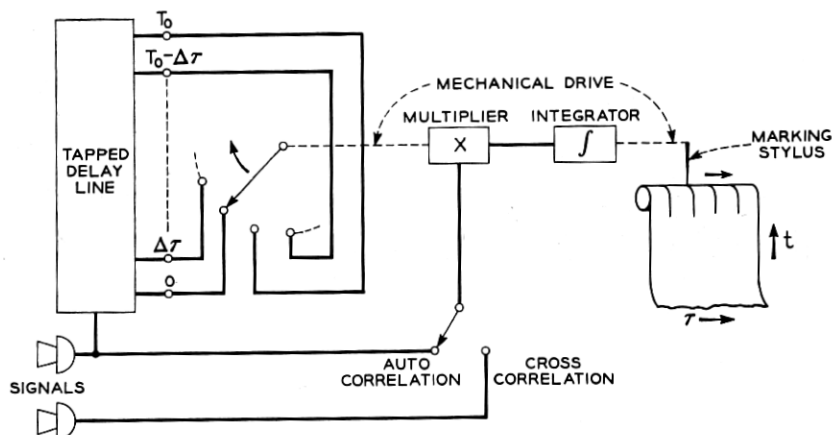

Fig. 3 — Mechanism of correlatograph with common multiplier and integrator.

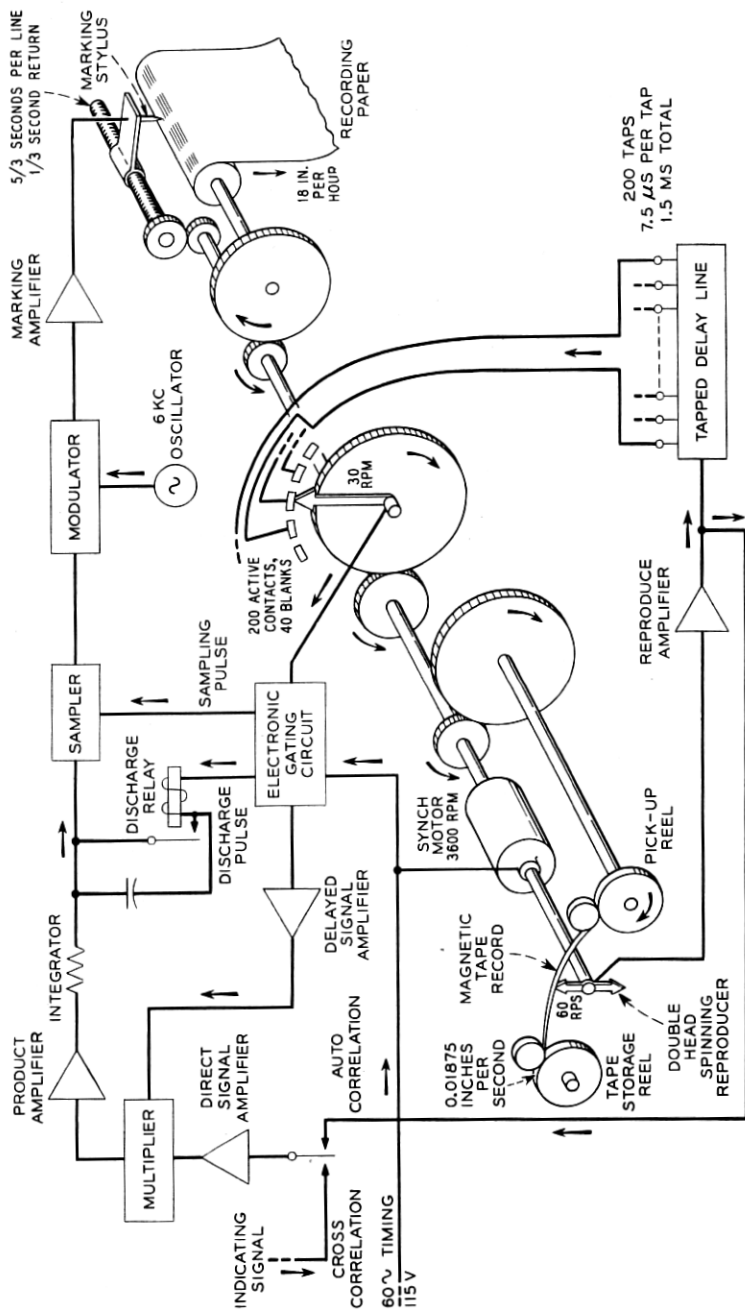

Fig. 4 — Arrangement of apparatus for correlatograph described.

per second brings a correspondingly different signal band into the range of the delay line. The magnetic tape advances relatively slowly during the scanning process and for any one scan of a one-inch section may be regarded as stationary. The revolving pick up thus delivers segments of signal $1/120$ second (8.33 ms) long for the correlation analysis. Our delay line consists of 1.5 ms total delay with 200 taps spaced $7.5 \mu\text{s}$ apart. During the first 1.5 ms of each scan, the delay line contains parts of the response from two successive scans and hence is not suitable for correlation measurement for lag times corresponding to all taps. We make provision therefore for excluding this interval from the analysis and use only the last 6.83 ms of each scan. The rotating switch advances one tap on the delay line for each one inch scan, so that the value of short term correlation corresponding to one value of lag time is computed every 8.33 ms. 200 values are computed in 1.67 sec after which a time of 0.33 sec is allowed for the return of the marking stylus to its initial position. The rotating switch thus makes one revolution in two seconds but the last sixty degrees of the revolution are not used for display of correlation. The recording paper advances 0.01 inch after each stroke of the stylus. The rate of advance of the signal tape is adjustable by means of a gear train. In terms of the original signal wave, one second of recorded time is represented by the distance the paper moves in one second (0.005 inch) multiplied by the ratio of recording speed to speed of tape advance past the scanning head.

The tape scanning mechanism with the synchronized motion of stylus and paper is due entirely to I. E. Cole, who designed this part of the system and supervised the necessary shop work. Mr. Cole also cooperated in the choice of a design plan for the rotating switch, which was manufactured to meet our special requirements by Applied Science Corporation of Princeton, N. J. The switch output is followed by an electronic gating circuit which removes the effect of time jitter in the beginnings and ends of the contact intervals and trims off the previously mentioned 1.5 ms interval during which the tail end of one scan of the tape loop remains in the delay line. The gating wave is generated from the common 60-cycle power supply which drives all the mechanical apparatus. The output of the electronic gating circuit consists of segments of signal 6.83 ms long with 1.5 ms separation and with the delay increasing in steps of 7.5 microseconds between one segment and the next. This constitutes one input to the multiplier; the other input is the undelayed signal in the case of autocorrelation or an independent signal for cross-correlation.

The multiplier consists of a bridge of germanium varistors with the two

inputs applied across the two diagonals and the output taken off one pair of input terminals through a low pass filter. Each varistor is operated in a substantially square law range. If A and B represent the two inputs, we try in effect to produce an output proportional to

$$(A + B)^2 - (A - B)^2 = 4AB.$$

The necessary conditions are conveniently expressed in terms of sine wave inputs in order that analyzer measurements may be used as a check on accuracy. Let $P \cos pt$ represent a typical component of the signal impressed as one input to the multiplier and $Q \cos qt$ a typical component simultaneously applied to the other input terminal. The product is

$$(P \cos pt)(Q \cos qt) = \frac{PQ}{2} \cos (p + q)t + \frac{PQ}{2} \cos (p - q)t.$$

Since our purpose is to integrate the output of the multiplier over a time interval relatively long compared to the periods of components within the signal band, we have no interest in the product component of frequency $p + q$ and in fact filter out such components immediately along with the original signal components to prevent loading the product amplifier with unessential waves. A significant test on the accuracy of the multiplier is therefore the fidelity with which the amplitude of the difference frequency term $\cos (p - q)t$ follows the product of the amplitudes of $\cos pt$ and $\cos qt$. This is not sufficient in itself however because it does not give a check on the balancing out of the squares of the individual inputs. To test the latter we superimpose the two components $P \cos pt$ and $Q \cos qt$ on one input circuit with no signal applied to the other input and measure the output component of frequency $p - q$. We also repeat the measurement with the two sine waves impressed on the second input and nothing on the first input. Typical results are shown in Fig. 5. The varistors were selected by R. R. Blair from persistent screen cathode ray tube displays of the characteristics. The square law region is enlarged and the output increased by applying a direct current bias to the bridge through a series resistance. This form of multiplier copies a design worked out by R. R. Riesz for a different purpose.

The product output of the multiplier is weak at best because a relatively small range of varistor inputs fit the necessary law. A fairly high gain product amplifier is therefore provided. Fortunately we do not have to amplify a band which extends all the way down to zero frequency. The significant component when calculating the autocorrelation function of $P \cos pt$ for lag time τ is $(P^2/2) \cos p\tau$, which is constant only when $p = 0$ or τ is constant. Our lowest value of p corresponds to 1600 cps. The value

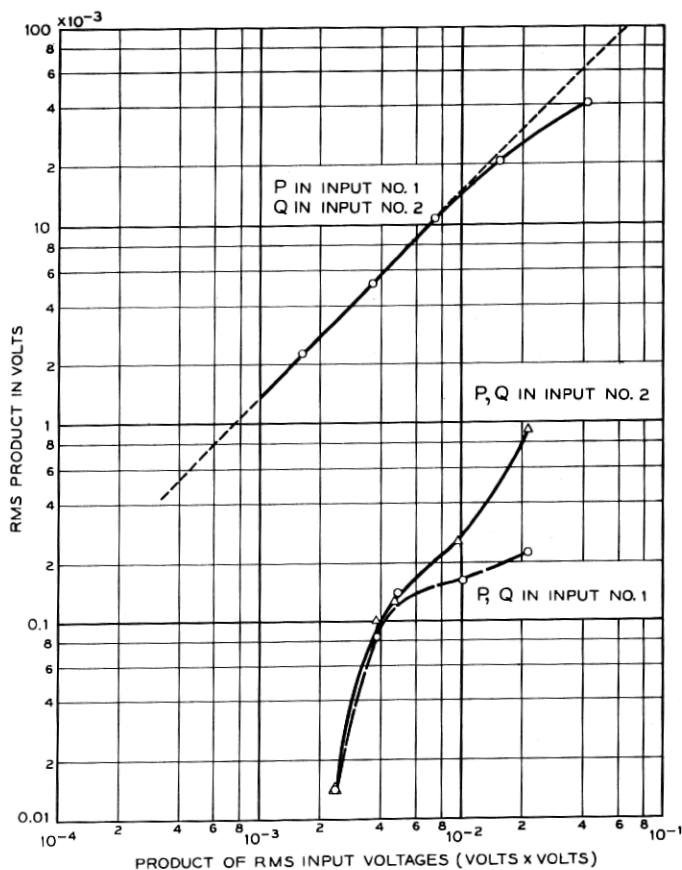

Fig. 5 — Performance curves of multiplier.

of τ increases in small steps from 0 to 1.5 ms in $5/3$ sec. and therefore can be approximated by $\tau = bt$, where $b = .0015/(5/3) = 0.0009$. Hence the lowest product frequency is roughly $1600 \times 0.0009 = 1.44$ cps. The actual low frequency cutoff of the amplifier is made about 0.1 cps to allow for changes in the signal components and to preserve good transmission within the nominal band. The upper cutoff frequency is likewise made somewhat higher than the nominal value of $32,000 \times 0.0009 = 28.8$ cps.

The integration is performed by a series condenser and shunt resistance at the amplifier output. A good approximation to integration is accomplished by a large time constant such that the indicial admittance

remains linear during the integrating interval. Such a long time constant would carry over too much charge from previous intervals if continuous integration were permitted so a shorting relay is provided to discharge the condenser quickly to ground after the integrated value is sampled. The sampling is done by a two-way clamp circuit with the timing pulse generated from the trailing edge of the pulses which gate the switch outputs. The shorting relay operates directly from the 60-cycle supply and is of a type specifically designed to give a brief closure of about one ms. every half period of the driving wave. The sampled outputs of the integrator are applied to a balanced modulator to which is also applied a 6-kc carrier. The resulting double sideband suppressed carrier wave is amplified to form the marking voltage applied to the stylus. Instantaneous compression is incorporated in the marking amplifier to extend the range of input magnitudes which are encompassed by the relatively narrow recording range of the paper. The stylus responds equally to positive and negative voltages and does not resolve the individual high frequency oscillations. The result is like full wave rectification of the correlation functions.

Grateful acknowledgement is given to A. J. Rack, A. E. Johanson and P. A. Reiling for suggested physical configurations and design information suitable for the circuits which generate the various control pulses, and which sample and hold the integrated outputs. G. W. Blake tested and adjusted these circuits after they had been constructed by the wiring shop. Performance runs were made by F. H. Tendick and N. K. Poole. Also at various stages of the project assistance was given by W. A. Klute, F. W. Kammerer and R. L. Carbrey. We have also received helpful advice from many other associates too numerous for explicit mention.

The 200-tap delay line was constructed by the transmission networks department. It consisted of one low pass filter section per tap with mutual inductance between sections to maximize the linearity of the phase curve. The taps were taken off high impedance shunts with the output fraction tapered down the line to give constant loss along the taps. C. E. Jakielski planned, assembled, tested, and adjusted the delay line. The intricate task of connecting the 200 output taps to the corresponding 200 contacts of the switch was performed by M. Biazzo. The delay line and switch appear in the photograph, Fig. 6. Additional electronic apparatus not shown in this photograph was placed on independent panels for experimental convenience but can be arranged in a chassis in the same cabinet with the other apparatus, now that the components have been determined.

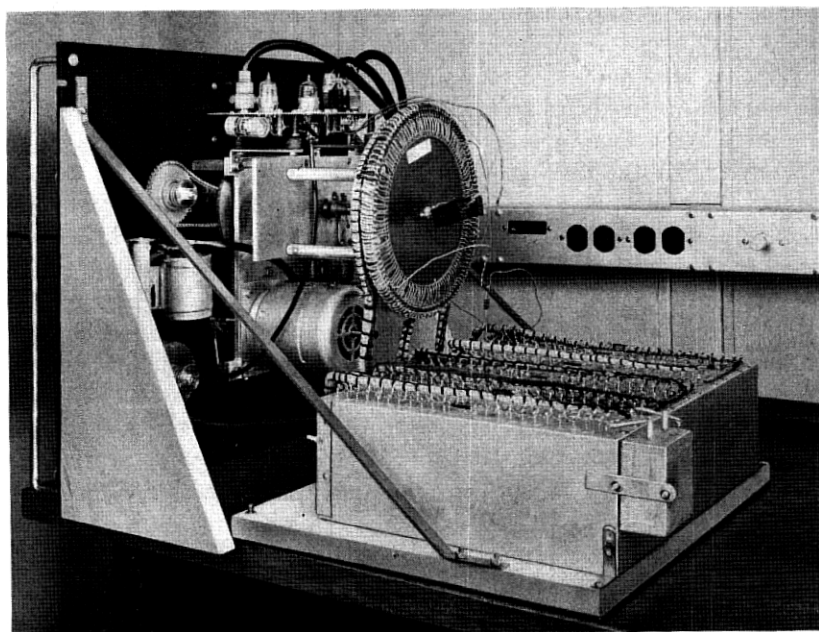

Fig. 6 — Rear view of correlatograph showing rotating switch and delay line.

PRELIMINARY RESULTS

Tests on the complete correlatograph have only been carried far enough to date to verify that the operation is as planned. Fig. 7 shows correlatograms obtained with purely sinusoidal inputs of frequencies 200, 400, 600, 800, 2,000, 3,000, and 4,000 cps recorded on the tape at 15 inches per second. In terms of the original signal the values of τ extend from zero to 12 ms. The profiles represented by the light and dark bands should be rectified cosine waves starting with a peak at $\tau = 0$ and repeating at intervals of one half the period of the wave. In the total range of $\tau = 0.012$ sec, a frequency of 200 cps should show 4.8 periods, 4,000 cps would show 96 periods, and in general f cps would show $0.024 f$ periods. The sudden changes in density parallel to the stripes were caused by manual adjustments of the marking amplifier gain.

Fig. 8 shows correlatograms of a 1,000-cps sine wave embedded in various amounts of flat thermal noise extending throughout the entire input band. The sequence from bottom to top is noise alone, signal and noise power equal, signal power down on noise power by 5 db, 10 db, 15 db, and 20 db. A long time correlation analysis would show zero correlations for the noise alone except for small values of τ . Short

term correlation gives a mottled background level. The signal pattern shows through this background quite plainly when the two powers are equal. As the signal is reduced relative to the noise the signal pattern is obscured and seems entirely missing at 20 db below the noise level. This is a limitation based mainly on the integration time of this particular apparatus. It is possible to improve the resolution by using longer integration periods with corresponding sacrifice of ability to detect fast changes in the applied signal. As pointed out by C. B. Feldman, the autocorrelation type of analysis suffers the same sort of limitations in the low signal-to-noise ratio case as filtering after detection imposes in spectral analysis. That is, finite integration time in the autocorrelation case and finite filter band width in the postdetection filter both allow errors from interaction of noise with noise to swamp the relatively small desired effect of signal.* Cross-correlation on the other hand is like filtering ahead of the detector in that the interaction of noise with noise is suppressed leaving as the dominant error the relatively small interaction of noise with signal. We cannot obtain this advantage of cross-correlation if we do not have available a noise-free signal to cross-correlate with, and analogously an accurate knowledge of the frequency to be selected is helpful in securing the best possible results from predetection filtering.

It will be noted that alternate stripes of the signal pattern fade at first as the signal is decreased relative to the noise. This effect appears to be associated with incomplete suppression by the multiplier of the components proportional to the squares of the individual noise inputs. If the noise inputs were steady, the squares would produce mainly direct current which is not transmitted by the product amplifier. Variation in

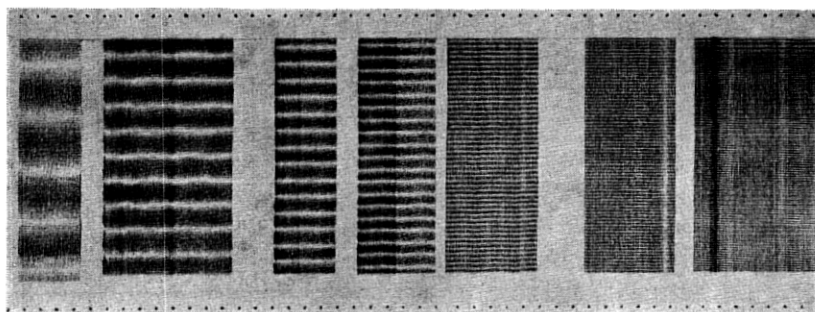

Fig. 7 — Correlatogram of single-frequency wave.

* The autocorrelation method however has an advantage if the signal can be recognized at all in that it is capable of measuring the frequency of the original components, which the postdetection filter cannot do at best.

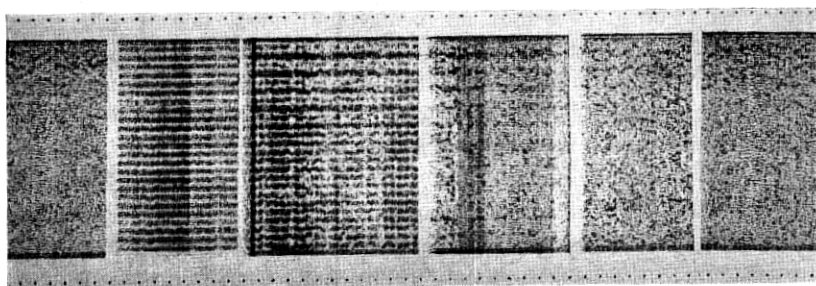

Fig. 8 — Correlatogram of single-frequency wave and random noise.

one noise input because of the idle interval during which no signal is supplied by the delay line is a source of change in the direct current which is partially transmitted through the product amplifier to give a biased integrated value and hence an unequal treatment of positive and negative correlation. Effects of this sort would be particularly noticeable when the noise is large relative to the sinusoidal component.

Fig. 9 shows a sample correlatogram of the sentence "He beats his head against the posts." spoken by G. E. Peterson. The locations of the sounds were marked on the tape by observation during an audio playback and from these marks the corresponding positions on the correlatogram were found. The lower legend gives the ordinary English letters and the upper the symbols of the international phonetic alphabet. The characteristic frequency indicated by the vowel sounds is of the order of 600 cps, which coincides very well with the first formant frequency of the speaker's voice. It is a characteristic of this method that the pattern is dominated by the largest component present. To show the higher formants, which have weaker amplitudes, it would be necessary

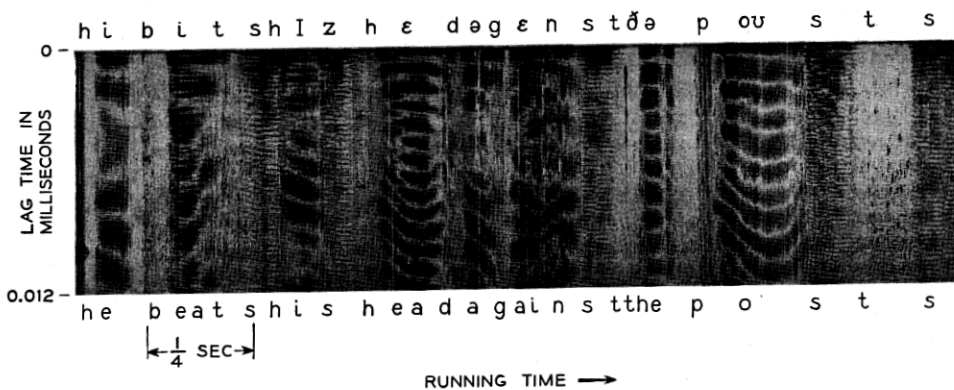

Fig. 9 — Correlatogram of speech sentence.

to filter out the strong low frequency components from the input. The "s" sounds show closely spaced stripes indicating a concentration of energy at the top of the band. Some of the consonants do not show much under the conditions of this test.

It is of interest to compare correlatograms with spectrograms of the same signal. For the single frequency input, the stripes on the correlatogram would be replaced by a single line on the spectrogram. It would be possible to construct signals such that these patterns are interchanged. For example, a rounded band of noise transmitted over two paths having different times of transmission would have a correlatogram with two stripes corresponding to lag times of zero and the delay difference while the spectrogram would show a periodic array of stripes corresponding to the interference pattern of the two paths. It appears that there may be complementary fields of usefulness for the two kinds of analysis and further study is planned.

Besides the many individuals previously named as contributing the various phases of the project, I would like to acknowledge the inspiration and guidance of R. K. Potter in initiating and carrying through the program. L. C. Peterson shared equal responsibility with the author in the project and but for his untimely death would have been a co-author of the present paper.

November 6, 1952

REFERENCES

1. W. Koenig, H. K. Dunn and L. Y. Lacy, The Sound Spectrograph, *J. Acoust. Soc. Am.*, **17**, pp. 19-29, 1946.
2. Y. W. Lee, T. P. Cheatham, Jr. and J. B. Wiesner, Applications of Correlation Analysis to the Detection of Periodic Signals in Noise, *Proc. I.R.E.*, **38**, pp. 1165-1171, 1950.
3. K. N. Stevens, Autocorrelation of Speech Sounds, *J. Acoust. Soc. Am.*, **22**, pp. 769-771, 1950.

