

An Experimental Electronically Controlled Automatic Switching System

By W. A. MALTHANER AND H. EARLE VAUGHAN

(Manuscript received February 15, 1952)

An automatic telephone switching system, built as a laboratory experiment, is described in which electronic techniques, high speed relays and a subscriber telephone with a pre-set dialing mechanism were employed. One-at-a-time operation within the office was made possible by these fast tools; that is, only a single control circuit was provided for each function. This experimental system, although not commercially economical, showed that an advantageous reduction in the number of control and connector circuits is made possible by this method of operation.

INTRODUCTION

This paper describes a laboratory experiment in automatic telephone switching systems. The investigation was conducted at the research level to gather valuable information and circuit techniques from a laboratory trial and not to evolve a system economically competitive with existing systems since the area of investigation is always broader and the results more general in character when the work is unfettered by economic restraints. Indeed, the results are not economically competitive.

Purposes of the investigation were to determine what advantages may be derived from faster operation, largely through the use of electronic techniques, and to introduce and test some previously unexplored philosophies in switching and signaling. Some of the basic tools employed were dry-reed relays, mercury relays, multi-element cold cathode gas tubes, cold cathode gas diodes, and thermionic electron tubes. An experimental subscriber's telephone set, incorporating a preset dial mechanism with circuits for generating dialing signals of a new form, together with suitable signal receivers for the central office was designed as well as a novel type of switching network with its control circuits. A basic aim of the experiment was one-at-a-time operation within the central office.

BACKGROUND AND OBJECTIVES

In many recent designs of dial telephone central offices, especially those in use in large urban areas, the subscriber's dial does not control directly the setting of switches leading toward the desired destination as was the case in early dial systems. Instead the information is received first by a register circuit which is selected from a group of such register circuits and is connected to the calling subscriber's line on the origination of a call. The register cooperates with other complex circuits to ascertain the location of idle trunks to the called subscriber's office and possible routes through the switching network to these trunks, and to control the selection and use of one such path to this called office. In the called office another register circuit, frequently of a type different from that into which the subscriber originally dialed, is selected from a group of such circuits and the directory number of the called subscriber is transmitted to it from the register-sender circuit in the calling office. In the terminating office the procedure of locating and testing the called line and switching paths to it, and of establishing a connection over one of these paths is accomplished through the use of additional control circuits. These various circuits which are used in setting up a conversational path are called common control circuits.

Each type of common control circuit is provided in sufficient number to handle the expected traffic. The number required is, of course, related to speed of operation since the shorter the holding time of a circuit, i.e., the length of time a circuit takes to complete its functions for one call, the more calls such a circuit can complete in a given time. The holding time of a control circuit is, in turn, dependent upon the operating speed of the equipment controlled. Furthermore, control circuits of the same type, if more than one of a given type is required, will have added to their normal functioning time during busy traffic periods a delay time interval since they must not interfere with each other's actions in the controlled equipment. Common control circuits, such as dial pulse registers, which receive information directly from subscribers must be engineered on the basis of an average holding time which allows for the variable reaction times, hesitations, partial usages and other personal idiosyncrasies of subscribers. Present designs of automatic central offices require a number of each type of control circuit and auxiliary circuits for selecting and connecting the control circuits as required in the operation of the system. These control circuits and connectors embrace a considerable fraction of the space and cost of such an office.

Dr. T. C. Fry, at the time he was Director of Switching Research

at the Bell Telephone Laboratories, suggested that a program be started to explore the possibilities of a new system which would require only a single control circuit of each type. This would require that each group of functions assigned to a common control circuit be performed on a one-call-at-a-time basis. It might be accomplished in a fresh approach to system design employing recent developments in high speed components. High speed in the common control units alone would not be sufficient. It would also be necessary to have fast switches since the operating time of a switching network is part of the holding time of the control circuit which operates the network. Similarly, since the signaling time is part of the holding time of the control circuit which receives and registers the signals, some form of high speed signaling would also be required. Further, the subscribers should have no direct control of the holding time of any common control unit. It was hoped that a great reduction in the number of common control circuits and connectors would result in a reduction in the size and cost of a central office even if the individual control circuits were somewhat more expensive. Furthermore, a speed permitting one-at-a-time operation would result automatically in faster service for the subscriber.

Consideration of the various factors of one-at-a-time operation was undertaken by the members of the Switching Research Department and possible system components evolved. Primary elements of inherently high speed, such as cold cathode gas tubes, thermionic electron tubes, dry-reed relays and mercury relays, were immediately adopted for the system. A network of high-speed switches with its high-speed control circuits was designed. A pre-set dialing device in the subscriber telephone set with transmission of high-speed dialing signals to the central office under control of common equipment in the office was selected as a means of eliminating the direct influence of subscribers on control circuit holding time. A code of high-speed signals, suitable for transmission over all existing types of local telephone facilities, with means for the pre-selection and controlled generation of telephone numbers was designed into the subset. Such a subset is necessarily complex since it becomes a form of manually operated register with all digits of a number stored before transmission to the central office. Circuits to control the generation of subset signals from the central office and receiver circuits to decode and register the signals were constructed.

These parts were then combined in the design of the Electronically Controlled Automatic Switching System, ECASS. A skeletonized laboratory version was built and tested to investigate the feasibility of combining the circuit elements and techniques, and to prove the operability

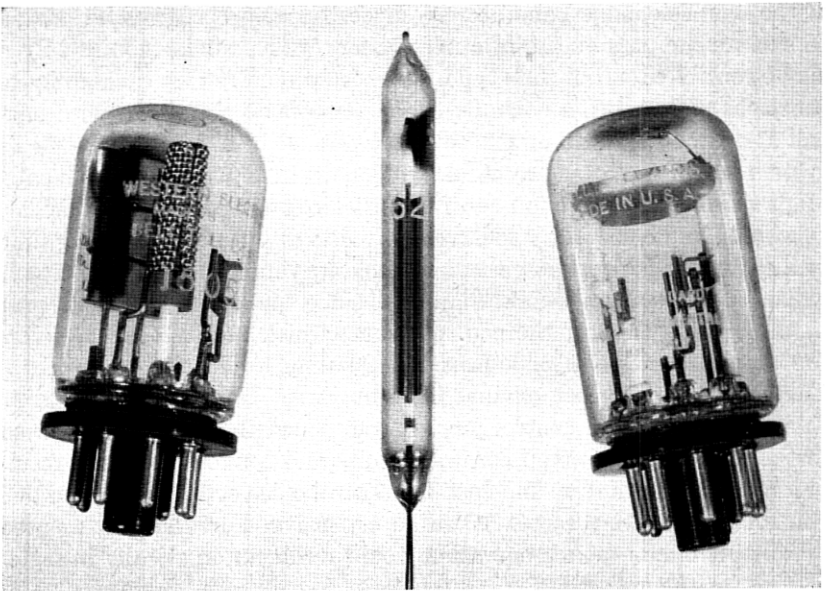

Fig. 1—Cold-cathode gas tubes—pentode, diode and octode.

of such a system. System operation is described in this paper after a more detailed discussion of the components mentioned above.

COMPONENTS

Cold cathode tubes, usually diode or triode types, have found widespread application in the past but the gas tubes used in the ECASS system were developed to have special characteristics for switching use. The three types of cold cathode gas tubes used were: a diode, a screen grid pentode and a multi-purpose octode. Fig. 1 shows a photograph of each type and Fig. 2 gives a schematic drawing of the internal elements. These tubes were developed by W. A. Depp and R. L. Vance. The diode

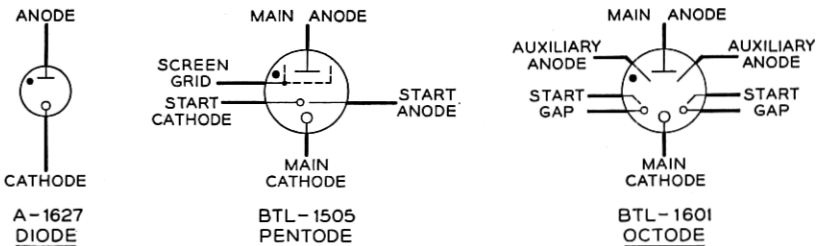

Fig. 2—Schematics of cold-cathode gas tubes.

is used at many points throughout the switching network, the screen-grid pentode in the path selection processes in the switching network, and the octode for miscellaneous purposes in the line, trunk, number group and other circuits.

The dry-reed switch, which is used as the contact element in many fast relays as well as in the metallic talking path through the office, is shown in Fig. 3. This switch consists of two permalloy rods sealed in opposite ends of a small glass tube which is filled with an inert gas. The overlapping ends of the rods normally have a gap between them and the application of a magnetic field coaxial with the reeds will cause them to pull together and close a metallic path from one rod or reed to the other through rhodium plating at the contacting ends. The dry-reed switch has an extremely small operate and release time, and because of the gas sealed and permanently adjusted construction provides a highly reliable dirt-free contact for low current applications. The dry-reed switch and relays employing it were developed by W. B. Ellwood. Mercury contact relays, also of a sealed and permanently adjusted construction, are used where fast operation at heavier currents is required. A sectional drawing

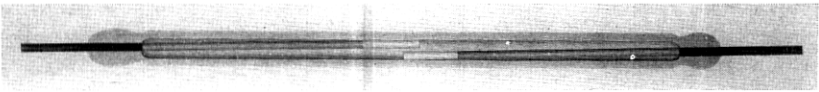

Fig. 3—Glass-sealed dry-reed switch.

of a mercury contact relay is shown in Fig. 4. These relays were developed by J. T. L. Brown and C. E. Pollard. Dry-reed relays and mercury relays are described in *Electrical Engineering*, Vol. 66, pp. 1104–1109, November, 1947, and in *Bell System Monograph*, 1516.

THE PRE-SET SUBSCRIBER'S TELEPHONE

In order to eliminate direct control of any common equipment by the subscriber and thereby to reduce the holding time of the dialed information receiving circuits and the associated subscriber-connecting circuits, the experimental pre-set dial telephone set shown in Fig. 5 was designed for this system by K. S. Dunlap, H. E. Hill and D. B. Parkinson. Eight selector finger wheels are grouped on a common shaft with only their edges visible across the front of the telephone housing. Each finger wheel is provided with ten indentations along its exposed periphery. Each indentation is designated by an engraved number or group of letters conforming to the telephone directory numbering system and each indentation is of suitable configuration to permit a subscriber's

finger to engage and move the wheel in either direction to one of ten detented positions. All of the wheels may be returned to their normal "zero" position simultaneously by depressing the release button on the front right corner of the housing. To place a call the subscriber positions each of the wheels so that the desired number may be read across the wheels on the line of indentations immediately above the lower edge of the enclosing frame. The first three wheels are set to the code of the called office and the next five to the called line directory number with the last of these being used for the party letter, if required. A number is preset in this manner before the handset is removed from its cradle across the back of the housing. With this method of operation the number may be rapidly and completely transmitted to the central office when its receiving circuit has been connected to the line.

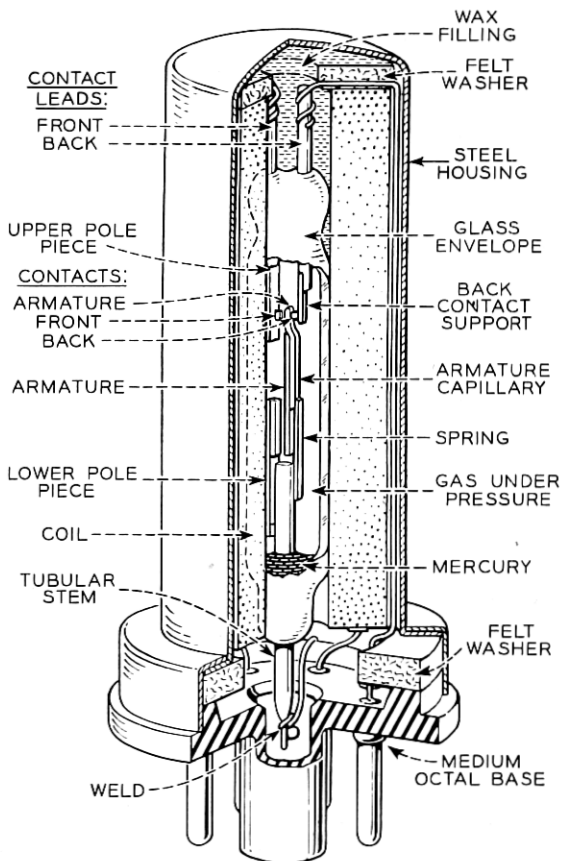

Fig. 4—Mercury contact relay.



Fig. 5—Pre-set pulse-position-dialing telephone set.

As shown in Fig. 6, which is a schematic of the mechanism and circuit of this telephone set, the handset when resting in its supporting cradle depresses the switchhook pins and causes two bell cranks to operate two sets of switchhook contact assemblies. One of these contact assemblies is controlled solely by the position of the handset while the other contacts are controlled jointly by the handset and by a magnetic locking device. This magnetic locking device consists of a permanent magnet yoke which holds the contacts in the position shown after the removal of the handset from its cradle until direct current of the correct polarity is allowed to flow in the windings of a latch magnet.

These two sets of switchhook contacts jointly control the connection of any of three subdivisions of the apparatus in the telephone set to the line to the central office. If the handset is removed from its cradle to originate a call, the free set of switchhook contacts releases to complete a circuit through the latched set of contacts to the signaling equipment of the station. In this signaling condition the voice transmission equipment remains disconnected from the circuit; thus, interference and transmission losses caused by voice transmission equipment are avoided during signaling. Upon completion of signaling direct current is provided from the central office to trip the latched switchhook contacts.

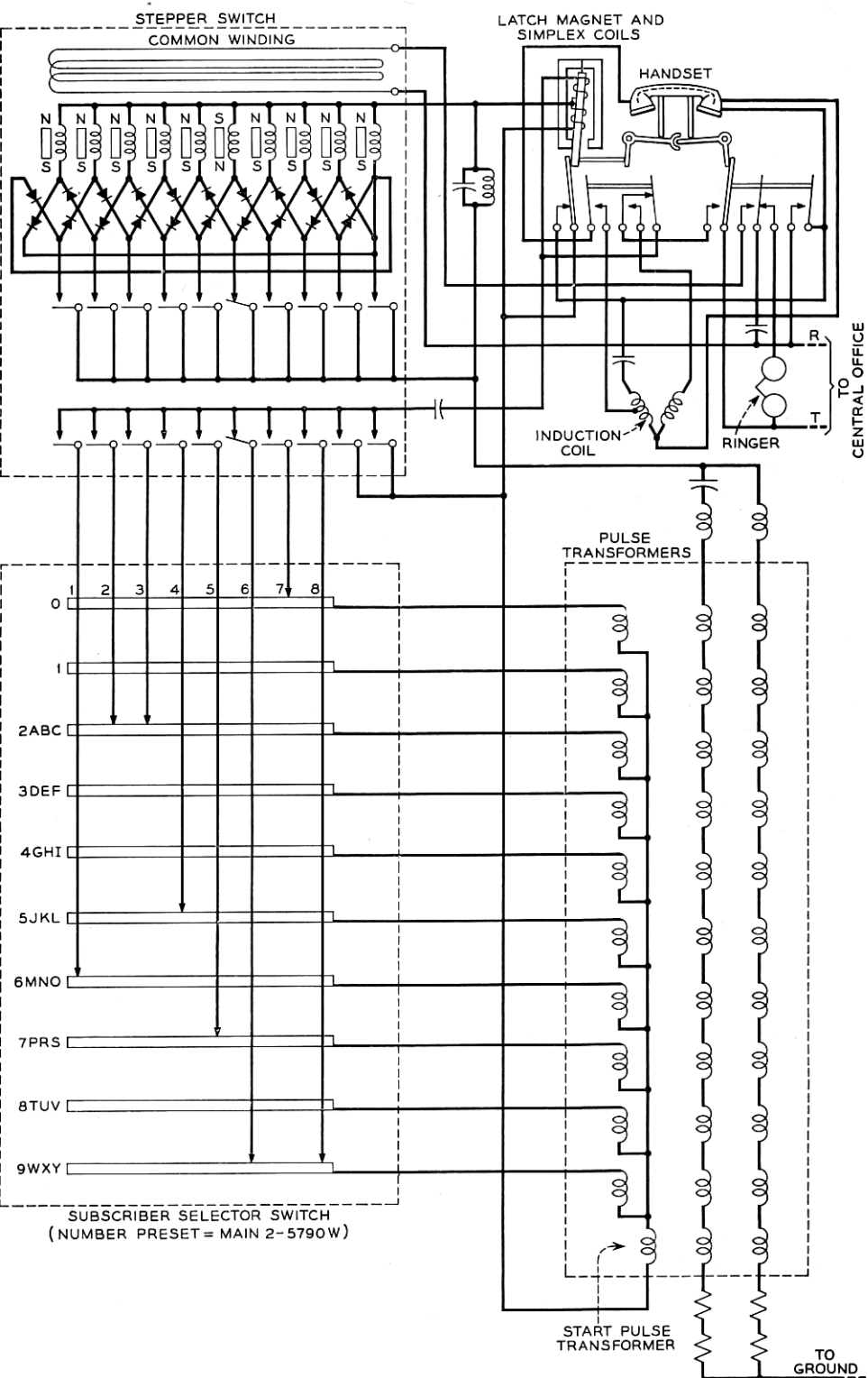

Fig. 6—Pulse-position-dialing subset schematic.

With both sets of switchhook contacts now released the usual transmitter, receiver and induction coil arrangement for transmission of voice currents is connected to the telephone line and all of the station signaling equipment, including the tripping windings of the latch magnet, is disconnected from the circuit. Interference and transmission losses caused by signaling equipment are thus avoided during conversation. When the handset is resting on its cradle between calls with both sets of switchhook contacts operated, the usual ringer and ringer condenser are connected across the line for responding to incoming calls. Upon removal of the handset in answer to such an incoming call, direct current is provided from the central office to trip the latched switchhook contacts and thereby the set is placed immediately in the talking condition.

PULSE POSITION DIALING SIGNALS

Before describing further the operation of this telephone set, it will be necessary to explain briefly the dialing signals generated by it and used in the system.

From the subscriber's telephone set eight digits are transmitted for a complete local area directory number and the transmission is repeated as many times as necessary for the functioning of the central office equipment. In order to indicate the starting point of the transmission of a complete called number, a time interval of two digits duration during which no signals are transmitted is provided at the beginning of each transmission. Each digit interval is 0.01 seconds; therefore, a time interval of 0.1 second is required for the no-signal or blank period and the eight digit number.

These signals, as shown in the wave form-time diagrams of Fig. 7, consist of two pulses per digit: a start pulse of 1 millisecond duration and a stop pulse of 1 millisecond duration, each pulse approximately a single cycle of a 1,000-cycle per second sine wave. The time interval between a start pulse and its following stop pulse is the measure of the associated digit value. The start pulses are generated at intervals of 0.01 seconds, or 10 milliseconds, and one stop pulse is generated some time during the 3.2 to 6.8 millisecond interval after each start pulse. In order to provide sufficient margins to permit reliable signaling over a wide variety of transmission facilities 3.2 milliseconds are allowed for the decay of each pulse and the pulses themselves occupy a section of the voice-frequency spectrum transmitted by practically all communication facilities. The possible starting times of stop pulses representing

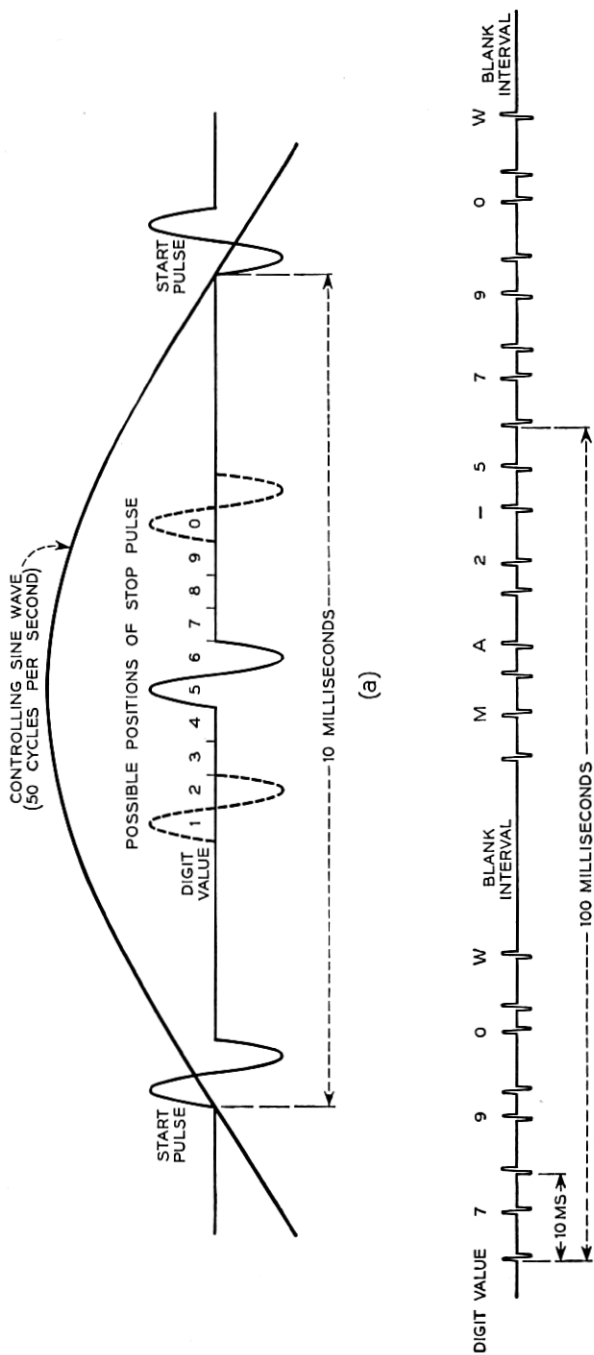

(b)
Fig. 7—Pulse-position-dialing signals.

digits of successive magnitudes differ by 0.4 milliseconds. Thus, digit 1 is represented by a start pulse followed by a stop pulse 3.2 milliseconds later; digit 2 is represented by a start pulse followed by a stop pulse 3.6 milliseconds later; and so on. It will be observed that the stop pulse for the digit 0 is 6.8 milliseconds after its start pulse and 3.2 milliseconds before the next succeeding start pulse. Thus, there is provided an increment of time of 3.2 milliseconds for the decay of the start pulse, increments of 0.4 milliseconds each for the generation of a pulse at any one of the ten times necessary to represent the various digits, and a last increment of 3.2 milliseconds to permit a stop pulse to decay should it occur at the end of the ninth increment of time.

Referring again to Figure 6, the signaling pulses are generated by the eleven pulse transformers shown. These saturation-type transformers are assigned, one for each of the numerals 0 to 9 and one for the start pulse. The excitation for the signaling apparatus is a constant amplitude 50-cycle current of sinusoidal wave form transmitted from the central office on a simplex circuit consisting of the two line wires to the set with ground return.* The currents from the line wires pass into the signaling apparatus through the windings of the latch magnet. These latch magnet windings thus serve also as a simplexing coil and since the excitation magneto-motive-forces in the two windings are mutually opposing there is no reaction on the latch itself.

From the simplex coil the excitation current flows through a stepper switch and its shunting phase shifter to a phase splitting network in which the current is converted to a two phase source with its two currents 90 degrees out of phase. Each of the pulse generating transformers has a single secondary and two primary windings. The primary windings of the transformers are serially interconnected and connected with the two phases of the excitation current so that one phase is applied to one primary winding of each transformer and so that the other phase is applied to the other primary winding of each transformer. The secondary windings are connected across the line through the pre-set selector, contacts of the stepping switch and a series capacitor. The secondary winding of the pulse transformer for the start pulse is in a lead common to all the stop pulse secondaries.

The magnetic core of each pulse transformer is designed to be saturated except for very small values of ampere-turns, and a voltage pulse

* The time interval spacings of signal pulses given in this section and in the following section on the signal receiver are based on a 50-cycle control current. The system operated satisfactorily on 50 cycles. However, in most of the laboratory tests a control current of 45 cycles per second was used since a stable source of this frequency is readily derived from commercial 60-cycle power sources.

is generated in the secondary winding of each transformer when the flux is changed from saturation at one polarity to saturation at the other polarity. The flux generated in the core of each transformer depends upon the number of turns in the two primary windings and upon the current flowing in each winding. In order to assure that all pulses be substantially alike as to wave form and amplitude it is necessary that the total maximum ampere-turns on each core be equal. In order to cause each transformer to generate a pulse at a suitable time during each half-cycle of the excitation current the total ampere-turns driving flux through the transformer cores must be controlled so that the flux in each transformer is zero at the time assigned to the pulse which that transformer serves to generate. These conditions determine the number of turns and the polarity of each winding when the angular position of the desired pulse is fixed in relation to each half-cycle of the basic excitation current.

Since the magnetic flux in each transformer is reduced to zero two times during each cycle of excitation current, it follows that a combination of two pulses representing a digit must occur during each half-cycle of the excitation current and that each combination of two pulses representing a digit is of opposite polarity to the preceding two pulses. The capacitor through which the pulse generating transformer secondary windings are connected to the line is so proportioned to the impedances of these windings and to the impedance of the line that each half-cycle pulse as generated by a transformer is applied to the line as a single complete cycle of alternating current of about 1 millisecond duration.

A selector switch, which is the internal mechanism connected with the finger wheels pre-set by the subscriber, serves to interconnect the transformer pulse windings with the line through the stepper switch. Thus, pulses representing any of the digits 0 to 9 may be impressed across the telephone line as any desired part of a complete telephone number in accordance with the setting of the selector switch.

The stepper switch employs ten relays of the glass-sealed dry-reed type and each of the relays has an individual coil surrounding two normally open reed contacts. The reeds are polarized by a permanent magnet of sufficient strength to hold the reed contacts closed but not strong enough to close them until assisted by current of the correct polarity through the winding. A reverse current through the winding is required to release the contacts. In addition a common winding is provided which surrounds all of the reeds in such a manner that when a current of sufficient magnitude is passed through the winding the reeds of a predeter-

mined delay will be closed and the reeds of all the other relays will be opened. This action is produced by reversing the individual winding and bias magnet of the single relay which is to be operated by the current through the common stepper winding. The preliminary setting of the stepper to insure correct operation is provided on each origination of a call by the discharge current from the ringer capacitor through the common winding of the stepper. The ringer capacitor is charged from the central office between calls.

One reed in each of the relays is employed to connect successive brushes of the digit selector switch with the line while the other reed in each relay in conjunction with two diode rectifiers per relay winding is employed to control the operation of the stepper. The stepping operation may be explained by reference to Fig. 6 as follows: The stepper is shown with the reeds for the sixth step closed. When the 50-cycle excitation current makes the terminal common to the individual stepper coils positive with respect to the terminal common to the stepping control contacts, current flows through the upper reed contact of the sixth step, a diode rectifier and the winding of the seventh step relay causing its reeds to close. With the seventh set of reeds closed current flows through a diode rectifier and the winding of the sixth step relay causing its reeds to open. The stepper will remain in this position until the reversal of excitation current a half-cycle later at which time a circuit through an oppositely poled diode rectifier will cause the operation of the relay for the eighth step followed by the release of the relay for the seventh step. The phase of excitation current through the stepper is so adjusted by the shunt phase shifting network that the stepper relays operate and release during the 3.2-millisecond guard interval preceding a start pulse. This prevents mutilation of the signal pulses. The stepping circuit is made reentrant so that the pre-set number will be transmitted repeatedly so long as excitation current is provided.

With the chosen 50-cycle excitation the complete transmission of eight digits and a two-digit silent interval takes only 0.1 second. This results in a short holding time for the central office receiving circuit and the repetitive signaling feature permits repeated trials in case of signal mutilation as well as direct dialing from the subscriber's telephone set to distant offices rather than some form of relayed signaling from registers in the subscriber's own office.

SIGNAL RECEIVER

A simplified block diagram of an experimental receiver for the pulse-position signals used in this system is shown in Fig. 8. The receivers

were designed by N. D. Newby and the authors of this paper. The signals after passing through a bandpass filter are amplified to a standard level by a circuit incorporating backward acting automatic volume control. The arrival of each signal pulse is detected by a threshold device. Since the minimum time interval between the generation of a pulse and the next succeeding pulse is 3.2 milliseconds, the threshold device is arranged to disable itself upon the detection of a pulse for about 3 milliseconds. This prevents false operations of the detector either by tail transients resulting from distortion of a pulse in the transmission medium or by noise occurring in this interval.

When the silent or blank interval which exists between the complete transmission of a number and its next repetition is recognized by the

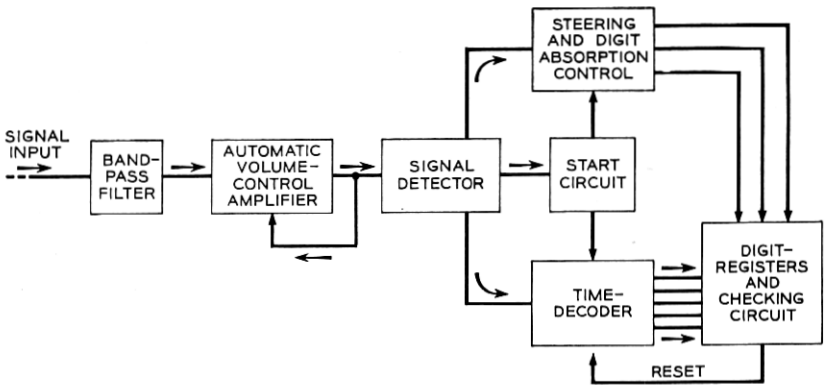

Fig. 8—Pulse-position-dialing receiver.

start circuit attached to the detector, the time-decoder circuit is enabled as well as the steering and digit absorbing circuit. The time decoder subsequently measures the length of time between each detected start pulse and the following detected stop pulse, and energizes the corresponding digit value leads into the registers. The steering circuit enables a separate set of register elements for the storage of each decoded digit which is to be used by its associated circuits and withholds such enablement through its digit absorbing features for digits which are not of immediate interest. The steering circuit also enables a check circuit associated with the registers.

Several features of the signaling code permit a check to be made that the received signals are in accordance with the code. The number transmission cycle has been already described but a brief restatement is made here to emphasize the checkable features: The first pulse following

the blank interval is a start pulse and eight start pulses at uniform 0.01-second time-interval spacing occur between blank intervals. One and only one stop pulse occurs between start pulses. The total number of signal pulses between blank intervals is sixteen. The check circuit utilizes one or more of these properties to insure that no signal pulses have been lost during transmission and that no extraneous pulses have been detected. If the actions of the check circuit indicate that an error in transmission has occurred, the receiver circuits are completely reset for another trial.

THE SWITCHING NETWORK

To meet the objective of a single common control circuit for the operation of the switching network, which provides the selectable paths between any subscriber and any trunk, it was necessary to have the switches in the network considerably faster than any of present commercial design. The laboratory model of the switching network and its associated path selecting equipment employing cold cathode gas tubes and dry-reed relays was developed by E. Bruce and S. T. Brewer. In addition to high operating speed this switching arrangement has certain other desirable properties: The idle path testing and selection functions are incorporated in the internal controls of the network. Busy sections of the network are automatically isolated from the sections tested for subsequent calls. Selection of a trunk within a trunk group, as well as path selection through the network, may be accomplished by the internal controls of the network if the trunks of a group are assigned one trunk per frame. Selection of an idle trunk and an idle switch path in combination reduces blocking. These internal selection controls eliminate many of the connector contacts that would otherwise be required between the switches and external common control circuits.

The switching network consists of line frames and trunk frames with each frame divided into primary and secondary switches. Each primary line and trunk switch has a number of vertical input columns across the switch to which are connected line or trunk circuits respectively and a number of horizontal output rows across the switch. At the intersection of each row and column of a switch is a relay consisting of an operating coil and three dry-reed make contacts. By analogy to the crossbar system which employs a somewhat similar rectangular array of rows and columns per switch and a similar primary-secondary path distribution, a switch intersection is called a crosspoint and a switch relay is called a crosspoint relay. In the crosspoint relay two of the contacts are used

to connect the talking conductors associated with the particular column to the talking conductors associated with the particular row. A cold-cathode gas diode is also associated with each crosspoint relay, and this diode in series with the winding of the relay is connected between the control lead of the particular column and the control lead of the particular row. The third contact of the crosspoint relay is used to short-circuit the associated gas diode. A typical crosspoint is shown schematically in Fig. 9. The use of these crosspoint gas diodes in the control leads facilitates the identification and selection of idle paths through the switching network and the short-circuiting of the diodes at operated crosspoints facilitates the holding of an established connection through the network at a lower power level than required for initial operation and the maintenance of a busy indication along an established connection during the path selection processes of subsequent calls. Dry-reed contact relays, rather than a more conventional type, are used in the crosspoints to provide the operating speed required for single control circuit operation.

Each secondary switch is a similar rectangular array except that the horizontal rows are used as input terminals and the vertical columns as switch outlets. Within a frame the horizontal outputs of the primary switches are interconnected with the horizontal inputs of the secondary

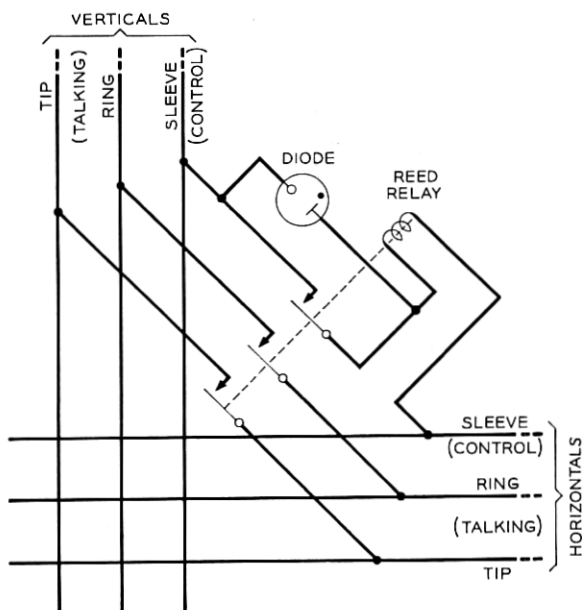

Fig. 9—Reed-diode switch—crosspoint connection.

switches so as to provide one path from each primary switch to each secondary switch.

Connections are made between the secondary line frame switches and the secondary trunk frame switches to provide talking paths between each line frame and each trunk frame. A direct metallic connection is made for the two talking conductors of each path but the control lead from each secondary line switch outlet is connected to an individual control circuit, called a junctor, and the control lead from a secondary trunk switch outlet associated with the same talking path is connected to the same control circuit or junctor. The size of the switches on each type of frame and the number of frames in each particular office will be determined by the number of subscribers and other offices connecting to this office and the calling habits of the subscribers served.

The operation of the switching network may be explained by reference to Fig. 10 which shows the control lead diagram of a skeletonized switching network of a large size office. This figure shows two line frames, each of which has two primary switches and two secondary switches. Three vertical inlets are provided on each primary switch and two vertical outlets on each secondary switch. The figure also shows two trunk frames, each of which has two primary switches and two secondary switches. The trunk switches provide two vertical trunk inlets on the primary switches and two vertical outlets on the secondary switches. Eight juncctors are required as indicated. This switching network then serves to interconnect twelve subscribers with eight trunk appearances. This is the actual size built in the experimental model.

As shown in Fig. 10 each control lead path between a primary and a secondary switch on both the line and trunk frames is connected through a high value of resistance to a -45 -volt power supply. In addition each control lead path from a secondary switch terminates in a similar resistor connected to a -105 -volt power supply. In a junctor involved in an established connection, such as junctor 5 of Fig. 10, the control leads connect to a -24 -volt source through low resistance relay windings. A talking path is shown as fully established between line C on line frame 2 and trunk D on trunk frame 2. This connection is held by the current flowing from the -24 -volt source in junctor 5 through the operated reed crosspoints in the line frame to a ground in the line circuit and in the same manner through the operated reed crosspoints in the trunk frame to a ground in the trunk circuit. The -24 -volt potential on the junctor leads and the resulting -12 -volt potential on the primary-to-secondary switch link leads are effective path busy indications for subsequent path selection operations in the network.

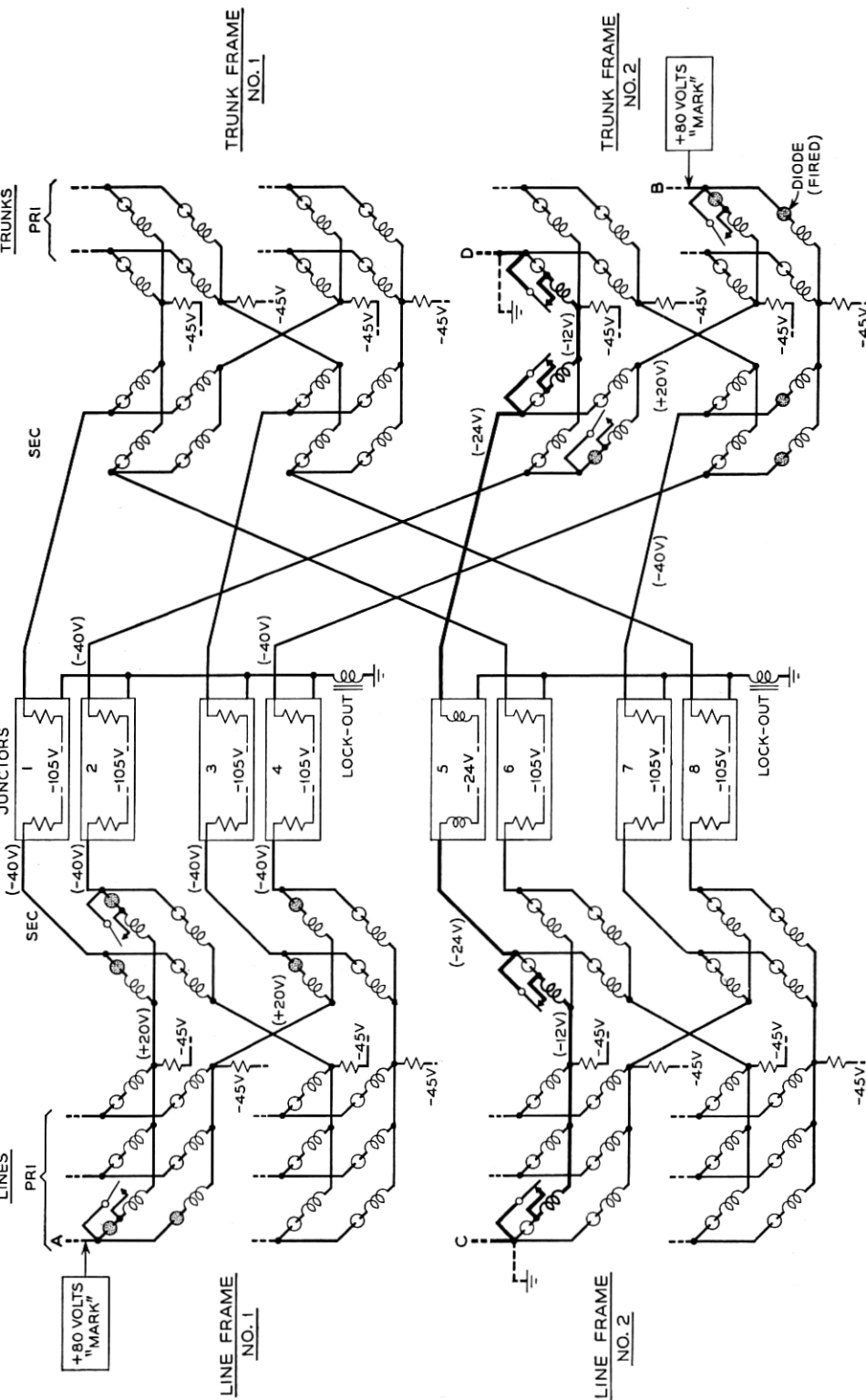

Fig. 10—Switching network control lead schematic—path marking, holding and busy voltage conditions.

If a talking path is now desired between line A on line frame 1 in Fig. 10 and trunk B on trunk frame 2, a +80-volt power source is connected to the control leads at these points. These applied voltages are called "marks" and originate in a number group circuit. The +80-volt mark at line A in conjunction with the -45-volts supplied to the primary-secondary switch links causes the cold cathode gas diodes of the line A vertical to fire and conduct at low current. The substantially constant voltage-drop characteristic of gas diodes causes the voltage on the two horizontal outlets of this primary switch to shift to +20 volts thereby "marking" one input lead on each secondary switch of this line frame. These +20-volt marks in conjunction with the -105 volts supplied from the junctors causes the gas diodes between the marked secondary switch inlets and the junctor outlets to fire, to conduct at low current and thereby to mark the associated junctors with -40 volts again by virtue of the gas diode characteristic. As indicated by the shaded diodes in Fig. 10 a mark on line A results in marks on junctors 1, 2, 3 & 4 and thus reveals all the idle paths from line A through the line frame.

In a similar manner the +80-volt mark applied to trunk B results in the firing of the diodes along the idle paths from this trunk to junctors 2, 4 and 7. The path to junctor 5, which is in use on the connection between line C and trunk D, is not marked in this case. The -24 volts presented by junctor 5 on its trunk control lead is not sufficient when combined with the +20-volt mark on the trunk primary-secondary link which leads to this junctor to fire the associated crosspoint diode.

For this desired connection there are two possible paths, either through junctor 2 or through junctor 4, as indicated by the -40-volt marks existing on both the line and trunk sides of these junctors. Selection between these paths is automatically accomplished by use of a lockout circuit which is common to all junctors serving the same line frame.

It is known that if a conduction path through a negative resistance gas tube is provided with a load impedance of proper value which is common to a similar conduction path through one or more other similar gas tubes, only one tube will ionize and remain ionized even if firing potentials are applied to several tubes either simultaneously or in sequence. Such a circuit employing two or more gas tubes with a common load impedance functions as a lockout circuit. The phenomenon is due to the region of negative resistance in the characteristics of the gas tube through which the tube current passes in the range between the breakdown and sustaining voltages. In this region as the current through a tube increases, the voltage across the tube decreases, tending to prevent other tubes with the common load from firing. To reduce the possibility that two

tubes fired simulatneously will then travel through this unstable region exactly together, an inductive element is used in the common load circuit. This increases the time interval required to traverse the unstable region thereby permitting differences between tubes to result in lockout.

In each junctor a five-element cold-cathode gas tube is used for path detection and selection. One control element of this tube is marked from the line side and other control element from the trunk side of the junctor if this junctor is usable in the call being set-up. The main anode is connected, together with those of the other juncctors of the same line frame, in a lockout circuit so that only the gas tube in one junctor can conduct in its main gap. The junctor in which the gas tube does conduct in the main gap is the selected junctor and the switching network path associated with it is the selected path. Assume that junctor 2 is so selected. It first shorts out the resistors in its -105 -volt supply leads. This permits a higher value of current to flow through the gas diodes along the selected path and causes the operation of the reed contacts associated with the crosspoint relay windings which are in series with the diodes. The control lead contact at each of these crosspoints, as shown along the selected path in Fig. 10, shorts out the gas diodes. With the diodes shorted out a further increase in the current operates relays in series with this control lead path in the line and junctor circuits. These relays cause the -105 -volt supplies in the associated junctor, junctor 2 in this case, to be replaced by the -24 -volt sources and the $+80$ -volt marks on the line and trunk terminals to be replaced by ground. This shift of power sources permits the gas diodes along paths marked but not selected for this call to extinguish but holds at a low power level the crosspoint relays along the selected path. With all diodes extinguished the switching network is ready for the next path selection operation. Removal of the ground at the trunk end of an established connection, at the end of conversation, results in complete release of the associated operated crosspoints and junctor.

With a central office traffic rate during busy hours of 50,000 calls per hour, 50 milliseconds is the maximum allowable holding time for a single common control circuit at 70 per cent usage. A single control circuit, even during its busiest periods, should not be in use more than about 70 per cent of the time. If the usage is increased beyond this point the delays which other circuits encounter in attempting to use the common control circuit increase very rapidly. This produces the same effect as increased control circuit holding time.

The holding time of the control circuit for the switching network determines the traffic capacity of the switching arrangement if only a

single control circuit is provided. The control circuit holding time, in turn, consists of three parts: operate and release times of connector relays, line testing and "marking" times, and the operate time of the switches and junctors. The average holding time for the control circuit of the switching network for the system described was about 40 milliseconds. This is considerably shorter than the maximum 50 milliseconds permissible under the heavy traffic conditions of the preceding paragraph.

SYSTEM OPERATION

An experimental skeletonized ECASS constructed for laboratory tests is shown in Fig. 11. The equipment is located on these frames from left to right as follows: Frame No. 1, line and originating actuator circuits, switching network and controls; Frame No. 2, trunk, outward actuator and number group circuits; Frame No. 3, originating receiver circuits; Frame No. 4, power supplies; and Frame No. 5, terminating receiver circuits.

Without further detailed description of the various component circuits the successful placing of a call through the system may now be traced by reference to the block diagram of Fig. 12.

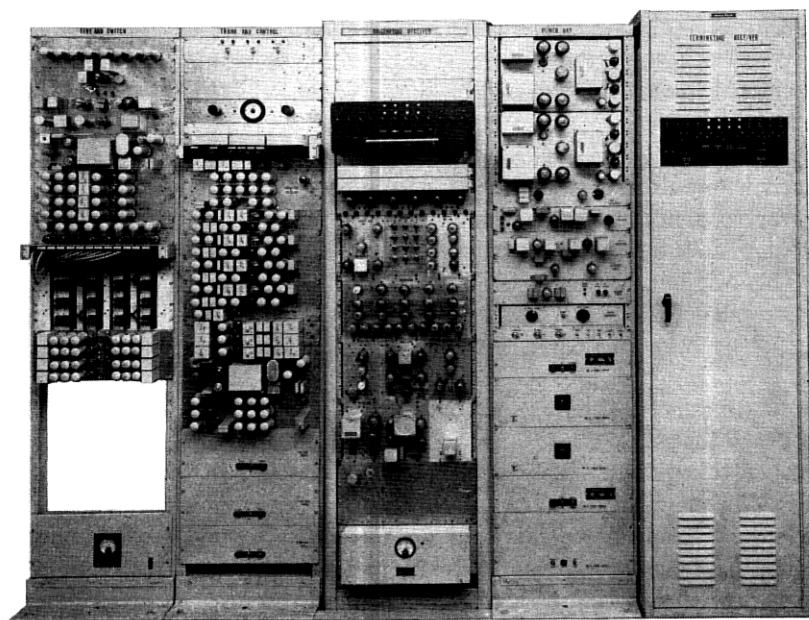

Fig. 11—Skeletonized laboratory model of ECASS.

A subscriber in originating a call first pre-sets the complete called line number on the finger wheels of his subset. The subset has been "latched" in the signaling condition by the mechanical reset on hanging up after the previous call. When the subscriber then removes the handset of his telephone from its cradle a line relay in the central office operates in recognition of a demand for service. The line relay in turn energizes a start gap of an associated cold-cathod gas tube. The gas tubes for a group of lines are connected in a lockout arrangement such that only one gas tube at a time can conduct in a main gap. When the tube does conduct in the main gap it operates a relay which connects the associated line directly to a common originating actuator and receiver circuit. During the short period that one line is attached to the receiver, originating service is withheld from all other lines in the same group but incoming calls may be terminated to any idle line.

The name, actuator, in this system refers to a circuit which includes an amplifier for transmitting 50-cycle current to a subscriber's subset over the simplex. This current is maintained at a constant amplitude despite the differences between various subscriber loops and the possible presence of earth potentials by the high output impedance of the amplifier. This high output impedance is obtained by the use of 35 db of feedback from the output of the amplifier. In addition, the actuator circuit also monitors its 50-cycle current flow when connected to a subscriber loop as the means of maintaining supervision since no direct current is permitted in the loop during the signaling period. The 50-cycle current in the subscriber's set causes the complete pre-set number to be generated repetitively as pulse position dialing signals which are returned to the receiver circuit in the central office over the loop. The use of simplex power to generate loop signals was adopted to simplify the filtering problem at the receiver circuits.

The originating receiver detects the dialing signals including the occurrence of the blank interval between repetitions of a complete number. It decodes the signals representing the first three digits following the blank interval, i.e., the called office code, and registers these digits unless the check circuit indicates that another trial is necessary. The action of the check circuit has been described in the Signal Receiver section of this paper. The receiver ignores the signals representing the called line number. Upon the successful registration of the called office code the originating receiver connects to the trunk number group circuit.

The name, number group circuit, in this system refers to a circuit through which a connection may be made to the switching network appearance of the control lead of any of a group of trunks or lines. In

the trunk number group a matrix of cold cathode gas tubes combines the three digits of an office code to establish a single lead control path to the equipment appearances of the trunks. This translator feature permits an arbitrary assignment between trunk locations and directory listed office codes. Another circuit, the subscriber number group, similarly includes translation of a called line directory number into the switching network line equipment number. Over such a control path a test is made of the idle, busy, or vacant condition of any designated trunk or line, and this same control path is used, together with other control leads to the switching network, to establish a connection through the switching network to this trunk or line.

If the test through the number group discloses an idle trunk, the control terminal of the trunk appearance on the reed-diode switches is "marked" with voltage over the same busy-testing path and the control lead of the calling line appearance is similarly "marked" over a path extending through the receiver-actuator connector. These marks from opposite ends of the switching network cause the selection of an idle junctor located in the connecting leads between line and trunk frames. The selected junctor in turn functions to make the marks effective in operating the switch crosspoints of all four switch stages as described

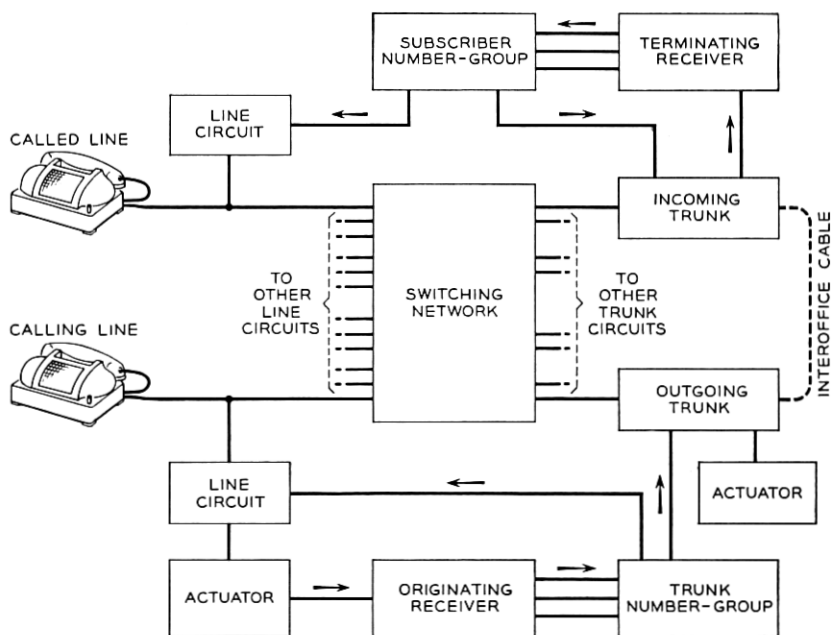

Fig. 12—Block diagram of ECASS.

in the section on Switching Network. The marking and switch operating voltage is applied to the line terminal of the switches through a line cut-off relay, which operates on the increased current which flows in this circuit immediately after the diodes in the switch crosspoints have been shorted out. The operation of the line cut-off relay releases the originating actuator and receiver which were connected through back contacts of this relay and, in turn causes the release of the trunk number group.

The next step is to send the called line number over the outgoing trunk so that the distant office may complete the connection to the called subscriber. An outward actuator is provided for this purpose. A relay in series with the marking path in the outgoing trunk circuit operates to connect the outward actuator directly to the trunk. The trunk-to-actuator connector circuits include gas tube lockout to insure that only one trunk is connected to the actuator at a time. During the short delay of awaiting an actuator that may occur during heavy traffic periods the established switching network connection is held under control of direct current supervision from the trunk circuit. The outward actuator, when connected, transmits 50-cycle current through the switching network to the calling subscriber's subset and maintains the connection by monitoring the 50-cycle current flow. This 50-cycle current causes the subscriber's set to transmit again the called number repetitively through the switches and outgoing trunk to the associated incoming trunk at the called office. In this paper it is assumed that all other offices connecting to this one are of the same type as this one or are arranged to transmit and receive, when required, the signaling pulse code used in this office. The arrangements in this office for completing incoming calls, including calls originating within this office itself, are shown in Fig. 12.

Operation of the connector relay which connects the outgoing trunk to an actuator signals the incoming trunk circuit in the terminating office to connect to an incoming receiver circuit for receiving the repetitive dialing signals. Connection between the incoming trunk and signal receiver is made through a lockout circuit which insures that only one trunk is connected to the receiver. When the incoming receiver has absorbed the office code, registered the called line number and checked the registration, it causes the incoming trunk to transmit a reverse battery pulse to the outgoing trunk as a number-received signal. This reversal causes the outgoing trunk to dismiss the outward actuator and to trip the latch in the subscriber's subset to the talking position with direct current talking and supervisory battery supplied from the outgoing trunk. At the same time the incoming receiver connects to the subscriber number group for making an idle-busy-vacant test of

TABLE I

Connecting Times	Milliseconds
1. Calling line off-hook to connection to outgoing trunk.....	180
2. Incoming trunk seizure to ringing of called line.....	200
Total time to establish a call.....	380
Holding Times	Milliseconds
1. Originating receiver.....	165
2. Trunk number group.....	38
3. Switching network control (each usage).....	14
4. Outward actuator.....	291
5. Terminating receiver.....	184
6. Subscriber number group.....	38

the called line and for "marking", if idle, the called line control terminal appearance on the reed-diode switches. At the time of this test, a voltage "mark" is applied to the incoming trunk control lead appearance also. As before, these two "marks" from opposite ends of the switching network cause the selection of an idle junctor and in turn the operation of the reed crosspoints in the four switching stages along the selected path. The "marking" voltage is applied to the incoming trunk terminal of the switches through the winding of a relay which, operating immediately after the crosspoints, causes the release of the incoming receiver and places the switching connection under joint supervision of the called and calling subscribers. The line cut-off relay whose winding is in series

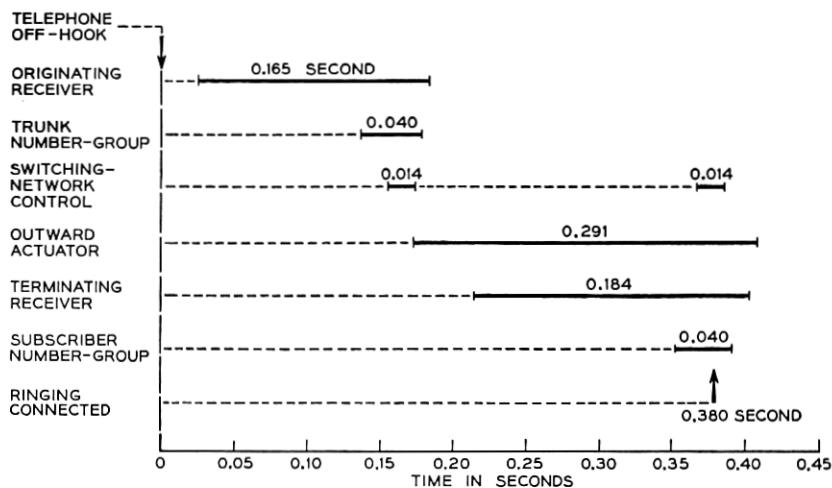

Fig. 13—Operating sequence based on average holding times.

with the marking path to the line appearance on the switches operates to remove the line relay and other originating apparatus from the called subscriber's line.

Based on the result of the idle-busy-vacant test of the called line, the incoming register circuit either sets the incoming trunk to provide ringing to the called subscriber upon closure of the crosspoints and ringing tone to the calling subscriber if the called line is idle, or sets the trunk to return busy tone to the calling subscriber if the called line is busy or vacant. In the latter case the incoming receiver is released immediately without setting up a terminating connection through the switches.

Since connections in the same reed-diode switching network are established through either of two number group circuits, lockout is provided between the originating receiver to trunk number group connector and the terminating receiver to subscriber number group connector so that only one number group circuit can be in operation at a time.

Some of the important average time intervals as measured in this system are given in Table I and shown graphically in Fig. 13.

CONCLUSION

The electronically controlled automatic switching system described in this paper was designed for large central offices and a skeletonized laboratory version has been built, tested and demonstrated. Successful operation at the speeds required was obtained. No failures of the gas tube lockout circuits were observed under the various combinations of possible simultaneous seizure. The experimental system shows that a large heavy traffic office could be made to operate on a one-at-a-time basis with advantageous reduction in the number of control and connector circuits. Many of the necessary components employed in this system for one-at-a-time operation are now available in a pre-development state and will probably be used in commercial systems. However, the commercial design and production of a complete office as described here is not economically competitive with existing systems since the subscriber subset and line circuit which are used in large numbers are too complex and expensive.

ACKNOWLEDGEMENTS

Although acknowledgements have been made in specific cases throughout this paper, we wish to point out that many others contributed to the success of the project. We wish to mention G. G. Bailey and G. A. Backman who performed the physical construction and assisted in the testing. In particular we wish to mention A. W. Horton, Jr., who directed the project.