

The Bell System Technical Journal

Vol. XXX

January, 1951

No. 1

Copyright, 1951, American Telephone and Telegraph Company

The Type N-1 Carrier Telephone System: Objectives and Transmission Features

By R. S. CARUTHERS

(Manuscript Received Oct. 17, 1950)

The N1 Carrier System is a 12-channel, double-sideband system for single cable application. It provides low loss, stable, high velocity service for toll and exchange circuits in the range from 15 or 20 miles to 200 miles. Units and sub-assemblies are miniaturized and arranged on a plug-in basis. Emphasis has been placed on reduction in cost of components, as well as simplification of manufacturing methods, engineering, installation and maintenance. Economy is achieved by many novel features, principal among which is a built-in low cost compandor. By compressing and expanding the volume range of speech, the compandor permits much higher tolerance of noise and crosstalk, thereby substantially lowering the cost of both line and terminal facilities. Other important features are self-contained dialing and supervisory signaling, an individual channel regulator, and automatic equalization through the use of "frequency frogging," or interchange of high- and low-frequency groups at each repeater.

INTRODUCTION AND GENERAL TECHNICAL DESCRIPTION

THE N-1 Carrier System is the most recent addition to the alphabetic list of carrier telephone systems which began in 1918 with the A system. This and many other systems produced since then have passed into obscurity. Others like the C, H, J, K, and L Systems* carry the majority of telephone traffic for distances exceeding 100 miles. Even though carrier has been the backbone of all the longer-haul telephone service in the country, these systems, and in particular the terminals, have been too expensive for short-haul use. This has prevented tapping the great mass of circuits owned largely by the Associated Companies and extending into nearly every city and town. The M system, developed primarily for power line use, has found limited application in this field.

The objective in the design of the N system has been to provide a single cable carrier facility which, without special cable treatment, will be economical for distances as short as 15 to 20 miles and which will be technically satisfactory in performance for a nominal maximum of 200 miles. Relaxa-

* See list of references at end of article.

tion of requirements, made possible by limiting the system to 200 miles (instead of the usual transcontinental 4000 miles), has been an important factor in helping to meet the low-cost objective. Elimination of the need for two cables permits use of a large part of the five million miles of toll and exchange circuits in Associated Company voice frequency cables for carrier operation.

An important aim of type N carrier is directed at the exchange plant where, even though the mileage is less, the number of circuits for exceeds that in toll use. Here the benefits of a high grade carrier facility are numerous. Exchange Plant makes use of a large percentage of small-gauge, high-capacitance cables, heavily loaded to reduce the net loss. Economically it is difficult to apply carrier or voice repeaters to these relatively short-length circuits. Many circuits to suburban points are now routed over toll trunks, because of the high loss of the exchange type circuits. Type N can be used to afford a low-loss, high-grade exchange circuit which can be switched in the manner usual for tandem and similar circuits. Low-loss trunks employing type N will be of great benefit in the ever increasing distances in the suburban areas between satellite points and their outlets. Direct, high-grade trunk groups, always at a premium and first selection of automatic switching equipment, can be increased in number.

Another important objective, in addition to the provision of a stable, low-loss, high-velocity talking circuit, is that of providing built-in signaling arrangements suitable for dialing and supervision. Such a system is urgently needed to meet the rapidly expanding demands of toll line dialing, as well as for exchange circuits. Such a signaling channel has been made available at a frequency just above and directly associated with the voice channel which it serves.

The emphasis placed on economy in the development of the N system has not resulted in a marked lowering of standards of performance. On the contrary, the N system, within its range of operation, sets new standards in many respects, notable among which is stability of net loss. The objectives have been met rather by a combination of new approaches and new circuit elements, backed up by closely coordinated cooperative effort in cost reduction of components, assemblies, and finally, of the complete system.

Among the many features making possible such a development as N1 Carrier, certain are outstanding. The most important of these is the compandor, a device for compressing and expanding the volume range of speech, thereby affording an improvement in the amount of noise and cross-talk which can be tolerated. The effects of the compandor are far reaching, both in the line and in the terminals. The need for expensive line treatment,

such as crosstalk balancing, is eliminated; band filter discrimination can be reduced; and signal levels can be raised without undue interference.

The N system employs a cable pair in each direction. In order to operate in a single cable the two directions are further separated by the use of different frequency bands; 44-140 kc for one direction on one pair; and 164-260 kc for the other direction on the other pair. Double-sideband, carrier transmitted operation, very similar to that of a radio system, is used, with channels spaced 8 kc apart. The voice channel bandwidth is 250-3100 cycles. The dialing and supervisory control frequency is at 3700 cycles.

Frequency frogging, involving interchange and inversion of frequency bands at each repeater, is accomplished by modulation with a 304 kc carrier, and serves two important purposes: Circulating crosstalk paths around the repeater are blocked; and the system is made self-equalizing for as many as ten repeater sections, having a gross loss of between 400 and 500 db.

Either paired or quadded, 16, 19, 22, or 24-gauge cable conductors can be employed, with suitable variation in repeater spacing. The nominal spacing of repeaters is 8 miles for 19-gauge and 6 miles for 22-gauge conductors. No limitation is placed on the percentage of cable conductors on which N carrier can be applied in a toll cable. Accordingly, as many as 1800 channels can be obtained from a 300-pair cable. For built up connections, two N systems can operate in tandem to make up a toll trunk. At the most, not more than 4 to 6 links of N are expected in tandem in a long multilink connection.

Many additional transmission features are listed and briefly described in Table I.

FREQUENCY ALLOCATION

The frequency allocation of the system is shown in Fig. 1. In order to coordinate system frequencies in the same cable some with odd numbers of repeaters, some with even numbers, and some circuits starting or stopping at intermediate repeater points of other systems, it is necessary to arrange the terminals to transmit and receive either high or low group frequency bands. The channel modulators and demodulators in the terminals, however, use carriers only in the high group band at 8 kc intervals between 168 and 256 kc. Thus, when transmitting high group frequencies to the line and receiving low group frequencies, the high group transmitting unit (HGT) merely amplifies the channel frequencies. The associated low group receiving unit (LGR) however, employs a group modulator with 304 kc carrier that inverts the received low group of line frequencies into the upper band for channel separation in the receiving channel band filters. When

transmitting low group to the line and receiving high group, the group modulator and 304 kc oscillator are used in the transmitting side of the circuit. Similarly, in the repeater, low and high group bands are interchanged between input and output lines through use of group modulators with 304 kc carriers.

Choice of the one group alone for primary modulation and demodulation of the speech bands stems largely from the desire to use only 12 designs of

TABLE I
TRANSMISSION FEATURES OF N1 CARRIER TELEPHONE SYSTEM

-
1. Built-in compandor affording an effective signal-to-noise improvement of 20-25 db.
 2. Frequency frogging and inversion to improve crosstalk and furnish automatic equalization.
 3. Built-in signaling equipment in each channel to provide supervision and dial pulsing. Tone on-tone off operation employing 3700 cycles.
 4. Message channel bandwidth 250-3100 cycles. Transmission of special services (telegraph and telephoto) through standard message channel equipment. 3500 cycle program channel plus 11 message channels, or 5000 cycle program channel plus 9 message channels provided by special program channel equipment.
 5. Automatic regulation of each channel at the receiving terminal by the individual channel carrier.
 6. All alarms built in with special carrier system failure alarm operating on transmitted carriers automatically freeing subscriber dial equipment.
 7. Use of noise generator where needed to mask intelligible crosstalk and obtain satisfactory performance in exchange type cables.
 8. Built-in resistance hybrid arrangements for 2-wire termination at non-gain switching points or alternative use of 4-wire termination at -16 and +7 levels for standard interconnection to existing broadband intertoll carrier systems. As much as +10 level is permissible for special purposes.
 9. Repeaters spaced at 8-mile intervals on 19-gauge toll cable and at shorter distances on high-capacity or smaller-gauge exchange cable.
 10. Power fed to pole mounted repeaters 8 miles (19-gauge toll cable) on either side of an office repeater, thus requiring power supply stations about 24 miles apart. Power is fed over the cable pairs by simplex connection and use of +130 volt and -130 volt batteries.
 11. Automatic regulation of line repeaters by thermistor flat gain adjustment, controlled by total output power of the 12 transmitted carriers.
 12. In service switching of repeater and terminal circuits.
 13. Small, lightweight, portable transmission measuring equipment for office and pole cabinet use.
 14. Simple order wire and alarm equipment provided to alarm power failures at unattended power offices and to permit communication with all repeater points.
-

channel band filters rather than 24. Easier filter requirements, occasioned by the use of double-sideband operation and the compandor, together with the fact that, for the high group, all harmonics fall outside the useful band, result in the elimination of the need for transmitting band filters. Thus, the only filter needed in the 12-channel group of sidebands and carriers is a common filter to suppress transmission of speech sidebands on harmonics of the channel carriers. An important factor in the choice of the high group for receiving channel band filters was the better performance obtained in the simple radio type slug-tuned coils in this frequency range, and the smaller size of condensers needed for tuning.

COMPANDOR

While the compandor principle is not new, it is believed that, for the first time, full advantage of the compandor has been taken in the design of a carrier system. To assist in explaining these advantages, general compandor principles will be reviewed in the light of the present development. The 1A compandor¹, designed more than ten years ago, has had considerable usage in open-wire carrier systems in reducing crosstalk, but in the N

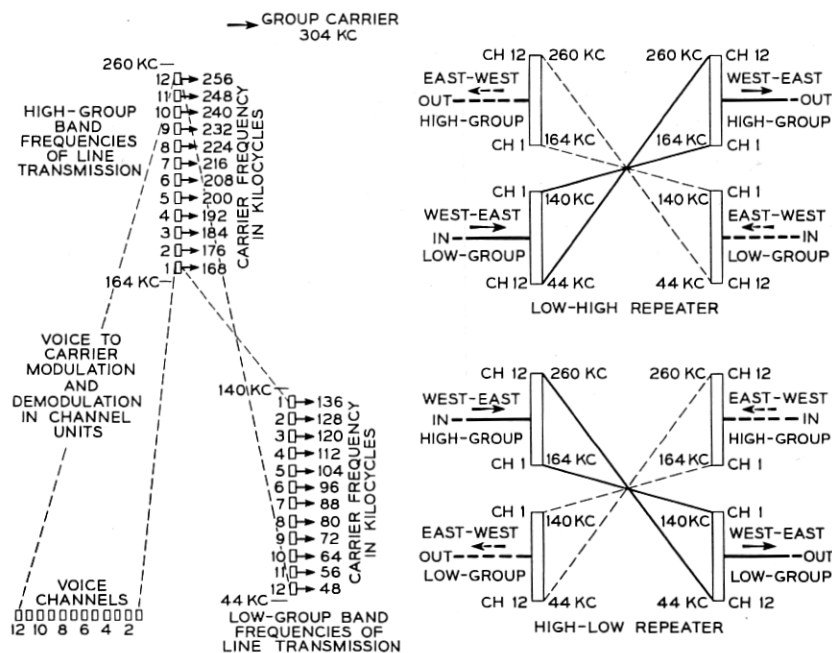

FIG. 1—N-1 carrier frequency allocations for terminals and repeaters.

system a more compact and cheaper unit was needed with requirements revised to match the reduced maximum length of circuits. The word compandor is a contraction of compressor and expander—the compressor in the transmitting terminal compressing the input range of speech volumes for passage over a wire or radio transmission medium where a variety of noise and crosstalk interferences are present—the expander in the receiving terminal expanding the received range of compressed speech volumes to the original range. A 20–28 db noise advantage is derived, and can be explained as follows: Weak speech volumes most susceptible to system disturbances are lifted and carried at higher level over an intervening noisy medium.

¹ Application of Compandors to Message Circuits, C. W. Carter, Jr., A. C. Dickieson and D. Mitchell—*A.I.E.E. Trans.*, Vol. 65, pp. 1079–1086.

The stronger volumes need less increase in proportion to the volume. When the circuit is idle 28 db gain is introduced by the compressor and 28 db loss by the expander. Any disturbance in the transmission medium in the absence of speech receives 28 db attenuation in the expander. Loss is removed from the expander as the speech volume increases and the noise increases correspondingly. In a well designed compandor with proper time constants the increased noise will tend to be continuously masked by the increased speech volume. Interferences to the listener during silent speech periods, such as intelligible crosstalk or audible tones, receive the full 28 db of noise suppression in the expander. Interference in the presence of speech receives less than full suppression in the expander the stronger the speech. Table II shows test results of noise advantage of the N-1 compandor at several noise values and speech volumes.

In Fig. 2(a) a level diagram shows the gain and loss introduced by the compressor and expander for signals of different strengths. A signal of 5 db

TABLE II
COMPANDOR NOISE ADVANTAGE

Thermal Noise (dba at 0 level)	Speech Volume at 0 Level			
	None	-30VU	-10VU	0 VU
53	28.0	24.7	24.0	20.3
58	27.0	22.2	22.2	19.9
63	24.0	20.0	17.8	17.2
68	18.5	17.8	14.6	13.7

above 1 milliwatt (+5 dbm) is shown as unmodified by compressor and expander. A signal input to the compressor of -50 dbm receives 27.5 db gain and the resulting -22.5 dbm signal input to the expander receives 27.5 db loss. For each signal input to the compressor weaker than +5 dbm by 2 db, the compressor introduces 1 db more of gain and the expander 1 db more of loss to a maximum of 28 db gain and loss respectively at -51 dbm input to the compressor or -23 dbm input to the expander. In Fig. 2(b) input vs output is plotted for compressor, expander and the combination. The slopes of these input-output plots are 1/2 for compressor and 2/1 for expander.

In Fig. 3, (a) and (b), compressor and expander circuit schematics are shown for the N-1 Carrier System. Compressor input and expander output are connected to the resistance hybrid circuit at the left of the compressor schematic for conversion to the 2-wire voice circuit input. Alternative connections for 4-wire operation and an adjustable gain control to establish over-all circuit net loss also are shown. Input voice signals to the compressor pass through the germanium variollosser, are compressed to half the input

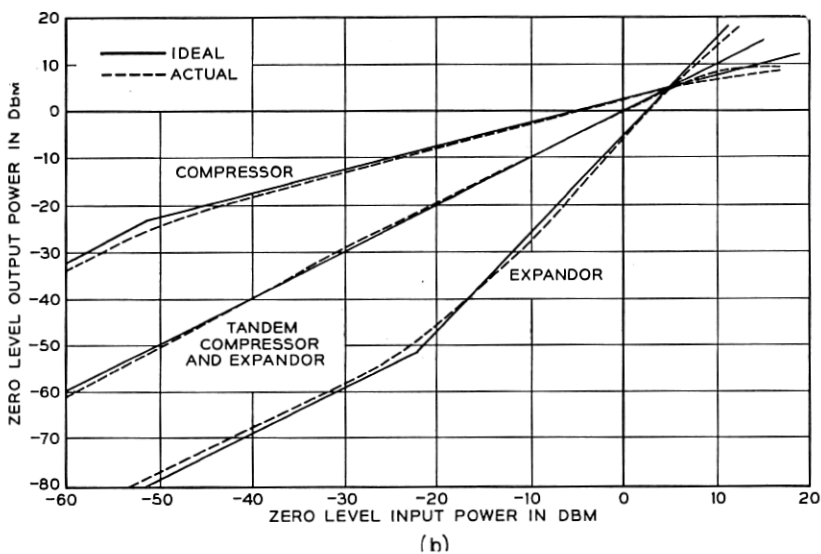
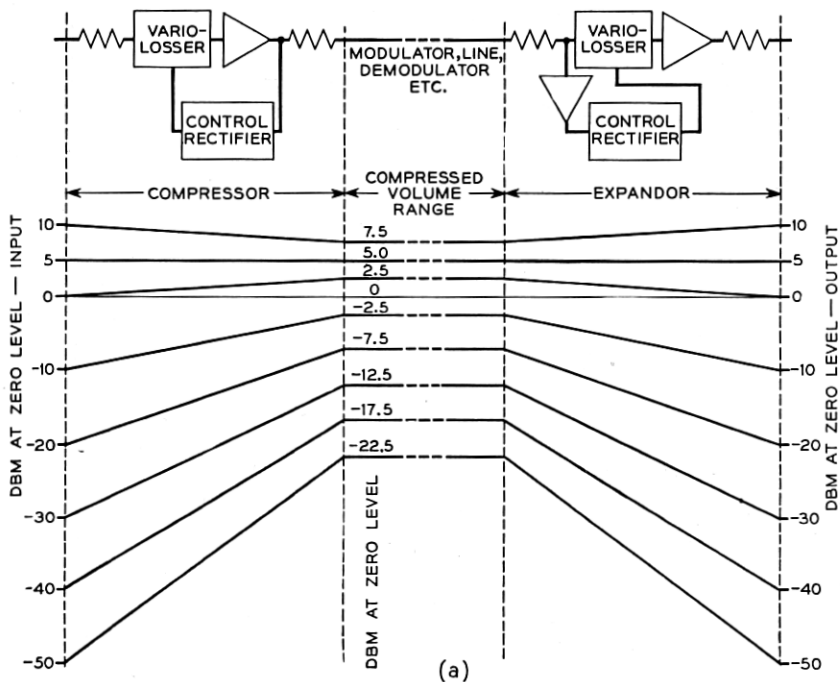
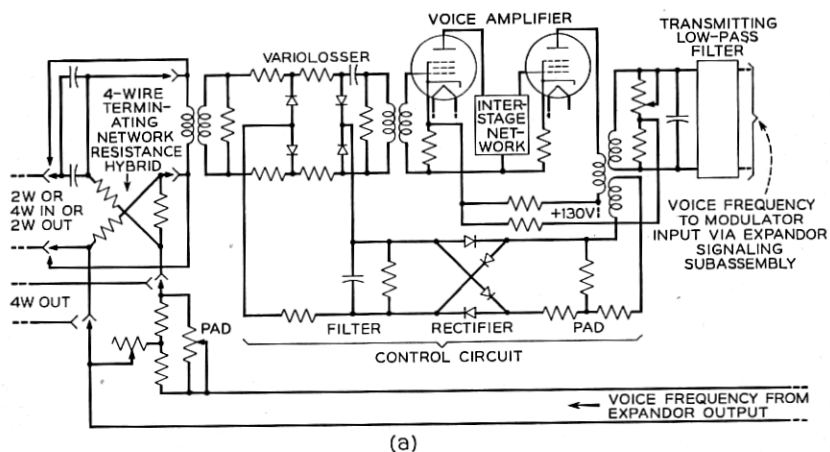
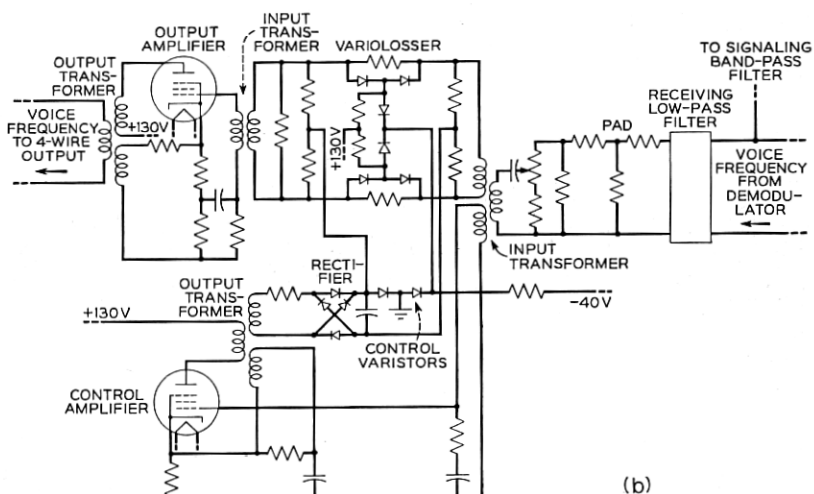

FIG. 2 (a)—Compandor action on steady tones of different levels.
 (b)—Input-output load characteristics of N-1 compandor.

volume range, then are amplified in a 2-stage feedback amplifier. Most of the amplifier output is fed through the control circuit where it is rectified in a germanium bridge circuit. A condenser-resistance filter in the control



(a)



(b)

FIG. 3 (a)—Channel compressor circuit.
(b)—Channel expander circuit.

circuit output passes only the rectified syllabic envelope of the speech frequencies. The control circuit filter output current is fed to the midpoints of the germanium variolossor bridge arrangement. The time constants of the control circuit filter are chosen for fast attack (3-5 milliseconds)²

² 90% of final value reached in time indicated.

to prevent syllabic speech bursts from overloading circuits following the compressor, and for slow recovery (30-50 milliseconds)² so that the variollosser will introduce fixed loss over a syllabic interval. Too slow a recovery time also is harmful, tending to leave the expander at low loss after the speech burst is over. Thus, the noise can be heard at the end of each syllable.

The expander in Fig. 3(b), like the compressor, consists of a variollosser, an output amplifier, and a control circuit which rectifies the compressed range of speech signals. Thus, the expander control circuit is operated by the expander input speech signal and is called forward acting, while the compressor control circuit is operated by the compressor output signals and is called backward acting. The rectified syllabic envelope control circuit currents in the compressor and expander are made as near alike as possible through choice of like circuit constants and levels, so that good tracking of compressor and expander variollossers will result.

Integration of the compandor into the design of the N-1 system from the start has yielded many advantages both from a line standpoint, and in repeater and terminal circuit and equipment design. A listing of these advantages follows:

Line

Operation to frequencies as high as 260 kc without need for far-end crosstalk balancing. Crosstalk in cable increases about 6 db as the frequency doubles and the ability to balance crosstalk becomes rapidly unsatisfactory above 60 kc. The N system with satisfactory crosstalk for 200 miles would be satisfactory for only one or two miles without compandors.

Repeater spacing can be about 25 db longer (40% more miles) than with no compandor, without limitations from near-end crosstalk or line noise. Less precise balance in line and equipment against longitudinal noise can be tolerated.

Longitudinal noise suppression coils are eliminated in voice pairs not used for carrier at repeaters in telephone offices.

Reflected near-end crosstalk requirements are eased markedly, thus ~ permitting much less precise equipment impedances.

Repeater

Poorer modulation can be tolerated, thus allowing 25 db less feedback, 25 db less non-regenerative gain and fewer repeater tubes. As many as 25 repeaters can be tolerated in tandem. Without the compandor even one repeater would make the system unsatisfactory from this standpoint. Repeater directional filter discrimination requirements are reduced by about 25 db.

Use of small and cheap filter coils and repeater transformers with permalloy cores is possible without harmful modulation.

Less precise transformer impedance and balance requirements, in conjunction with reduced size, eliminates the need of electrostatic shields between windings.

Terminal

Aids in elimination of transmitting channel band filter, and in large reduction of receiving band filter requirements.

Permits higher levels of carrier, speech and signaling tone without intolerable noise, crosstalk or interchannel modulation effects.

Equipment

Much more freedom is allowed in equipment layout and wiring, permitting more compacting, miniaturizing and less use of shield plates, shielded cans, and shielded wiring, without harmful noise pickup and crosstalk couplings.

Operation is feasible from common office battery with large reduction in individual circuit filtering. Signaling and speech circuits can be used on the same office battery without need for separate office wiring, fusing and alarms.

FREQUENCY FROGGING

Like the compandor, frequency frogging is vital to the N system, and numerous benefits result from its use. Primarily the purpose was to eliminate interaction crosstalk, i.e., crosstalk from the output of one repeater into a paralleling voice pair and thence back into the input of other repeaters. In K carrier cables this crosstalk path was eliminated by using two cables and at a repeater point connecting one cable to repeater inputs and the second cable to repeater outputs. The voice pair passing by the repeater point and remaining in the one cable thus was not exposed to both repeater inputs and outputs. In the N system in a single cable a modulator in each repeater frogs the frequency band from low group to high group, and in the following repeater back again from high group to low group. Thus, repeater outputs are always in one frequency band, and repeater inputs in the other, so that the crosstalk through the paralleling voice path can always be blocked by a filter at the repeater input. This approach is invaluable in N carrier where the alternative to frequency frogging is to use a second cable or to add suppression filters in all the paralleling voice pairs. In Fig. 4, cable frogging in K carrier and frequency frogging in N carrier are illustrated diagrammatically.

In addition to frequency frogging, the two frequency bands are inverted

in passing through the N repeater. Thus, the highest frequency channel in one line section becomes the lowest frequency channel in the succeeding line section. So nearly constant are the sums of the losses in two line sections for all channels for the frequency range chosen, that equalization is provided without resort to any major slope correction in the repeaters. The small amount of slope and bulge remaining are easily taken care of in the repeater through use of a few shaping elements in the feedback circuit.

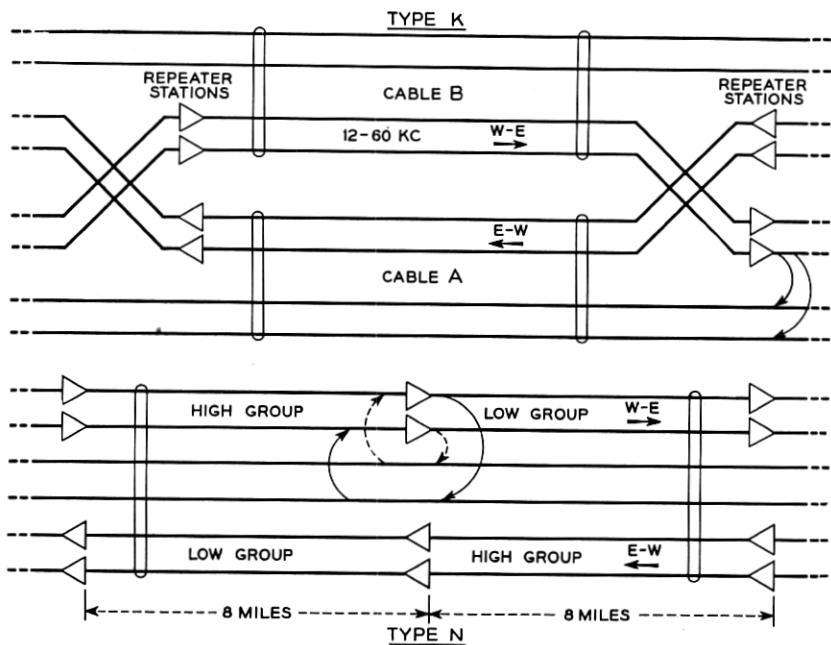

FIG. 4—Cable frogging and frequency frogging.

In Fig. 5(a) the sum of the line losses is shown for two successive 7.5 mile cable sections. The residual slope of only 3.7 db is in contrast to about 34 db of slope in two successive low-group sections in an unfrogged system. The flat line loss of about 90 db is accompanied by only about 0.4 db of bulge. Also shown in Fig. 5(a) is the summation of LH and HL repeater gains. The difference in slope between line and repeater amounts to about 1.5 db and is taken care of by a small range slope control in the repeater.

The remaining difference between line and repeater is nearly flat with frequency and is compensated for either through use of flat pads in the line (span pads) or through use of the repeater flat gain regulators. At about each tenth repeater enough frequency distortion has accumulated through lack of match between repeater and line to require use of a deviation equal-

izer. The anticipated shape of this characteristic, shown in Fig. 5(b), is based on 19-gauge cable and the deviations among the first 46 factory made

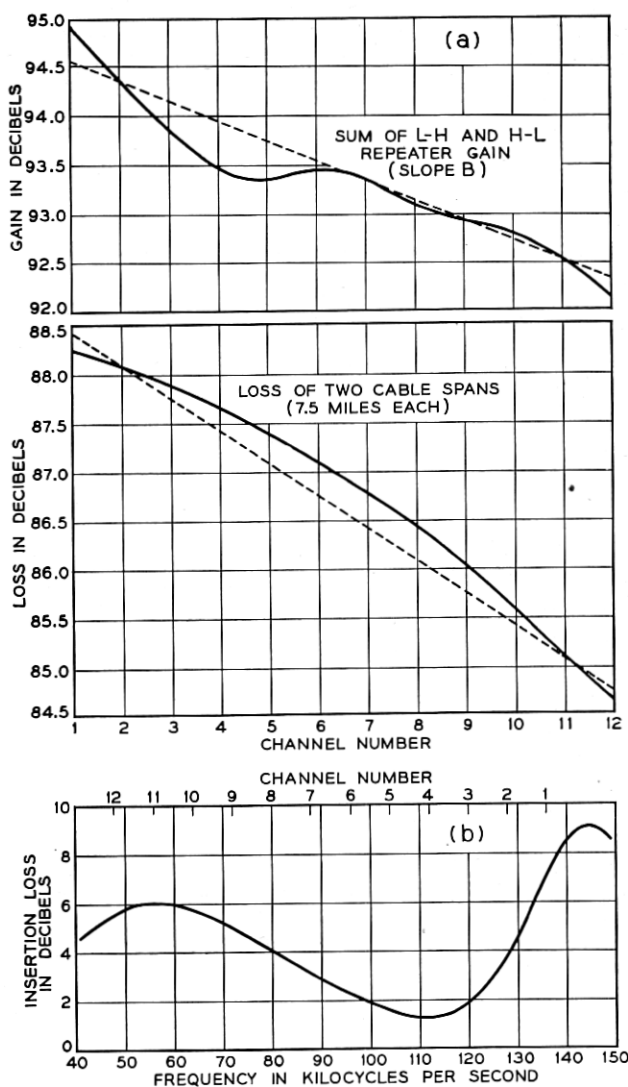

FIG. 5(a)—Repeater gain and cable loss characteristic.
(b)—Loss-frequency characteristic of deviation equalizer.

repeaters. More accurate determinations can be made by measurement of early systems in the field.

Because of frogging the maximum repeater gain is that required at the mean frequency instead of maximum line frequency. Furthermore, average repeater spacings required in opposite directions of transmission are identical. In a system without frequency frogging repeaters and using different frequency bands in the two directions, the average repeater spacings required in the two directions would be quite different. In the latter system, for various controlling reasons repeaters are installed at the closer spacing of the high-frequency group for both directions of transmission.

Frequency frogging and inversion also benefit regulation. With temperature change, a first order change in flat line loss occurs, a second order change occurs in slope and a considerably smaller bulge change occurs. In so far as the two successive line sections are at the same temperature, slope changes are nearly compensated. The bulge changes are so slight that they impose but small regulation requirements in the channel equipment even in a long system.

SIGNALING

Each voice frequency channel of the N system contains in addition to the compressor and expandor circuit, a signaling circuit operating at 3700 cycles for both dialing and supervision. Physically both the signal sending and receiving circuits are included in the expandor plug-in subassembly. The compressor and the carrier subassemblies, together with the expandor-signaling subassembly, comprise the channel terminal unit. Compressor and expandor-signaling subassemblies are alike and interchangeable among the 12 N channels. Carrier subassemblies differ only in respect to the oscillator and filters.

Signaling over the N system may assume a variety of forms. In ringdown operation 1000-cycle ringing signals may pass over the voice channel without need for the N signaling circuit, or, on the other hand, ringing may be converted to d-c. and passed over the N system by turning its 3700 cycle signal tone on and off. In dial operation digits are carried as in the national toll-line dialing plan either by multifrequency key pulsing or by dial make and break connections of a single-frequency tone. With multifrequency key pulsing the two frequency combinations of 700, 900, 1100, 1300, 1500 and 1700 cycles pass directly through the voice channel. Supervisory on-hook and off-hook signals, as well as dial pulse signals, are carried by turning 3700 cycles on and off. In addition, called numbers may be transmitted over the N system either by the operator verbally or by recorded methods of the panel call announcer system. Revertive pulsing and panel call indicator signals are not provided for in the N system, there being little need for N systems in panel offices where this equipment is used.

The N carrier signaling system uses 3700 cycle tone just out of the voice

band. The carrier channel bandwidth is made wide enough to carry both the speech band and signal tone. Use of 1600-cycle tone of the national toll dialing plan would impair the noise advantage of the compandor unless arrangements were used to by-pass the signal tone around the compandor. Because of the complexity and cost of these arrangements, 1600-cycle signaling is used over the N system only in special cases. The N signal tone is injected after the compressor in the transmitting terminal and removed before the expander at the receiving end of the system. Thus, the compandor is left free to operate on speech signals of various levels without interference and consequent impairment of its noise advantage by the signal tone. Use of the compandor permits an unusually high level of signal tone (0 dbm at 0 level in contrast to -20 dbm at 0 level for 1600-cycle signaling) without interference into the message circuits. In the compressor circuit [Fig. 3(a)] the compressor low-pass filter cuts the speech band off at about 3100 cycles, preventing speech interference to the signal channel. In the expander circuit [Fig. 3(b)] the expander low-pass filter passing the voice band blocks the signal tone from the expander.

In Fig. 6, (a), (b) and (c), the three parts of the signal circuit are shown—the signal oscillator circuit, the keyer circuit and the signaling receiver. The 3700-cycle oscillator is a resistance condenser Wien bridge type using a thermistor for stabilization of the output. One oscillator serves for the signaling supply of 12 channels. It is housed in the low-group subassembly of the group terminal unit. A low-impedance output circuit makes it possible to key on one channel or remove channels without disturbing others.

In Fig. 6(b) the signal keyer circuit is shown. On-hook or off-hook signals are received over the M lead from the trunk as ground and battery, respectively. With ground on the M lead the bias on germanium varistors in the keyer bridge becomes positive, which connects the 3700-cycle oscillator to the channel modulator through the keyer transformer. With -48 volt battery off-hook signal on the M lead, the varistors receive negative bias and 3700-cycle transmission to the modulator is blocked.

The signaling receiver [Fig. 6(c)] is connected to the output of the carrier channel demodulator in multiple with the expander low-pass filter input [Fig. 3(b)]. It consists of a receiving band filter about 150 cycles wide, an amplifier stage, a limiter, a cathode follower impedance converting stage, a germanium varistor rectifier, a delay circuit, a d-c. amplifier and an output relay. The band filter is made as narrow as practicable to reject noise and still pass sidebands of the dial pulses without perceptible distortion, with allowances for shift in the signal oscillator frequency and manufacturing variation of the band filter. The multivibrator limiter gives constant amplitude square wave 3700-cycle output for any 3700-cycle signal input to the receiver up to about 7 db below normal level and well above normal level.

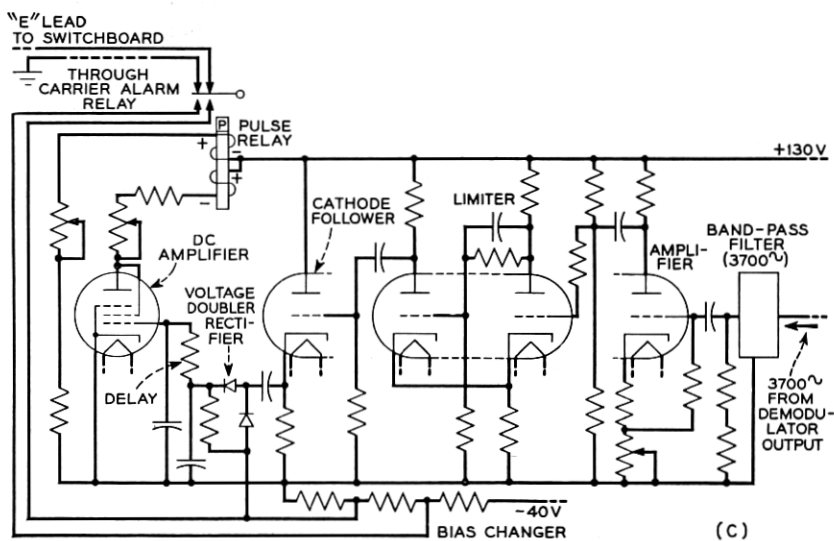
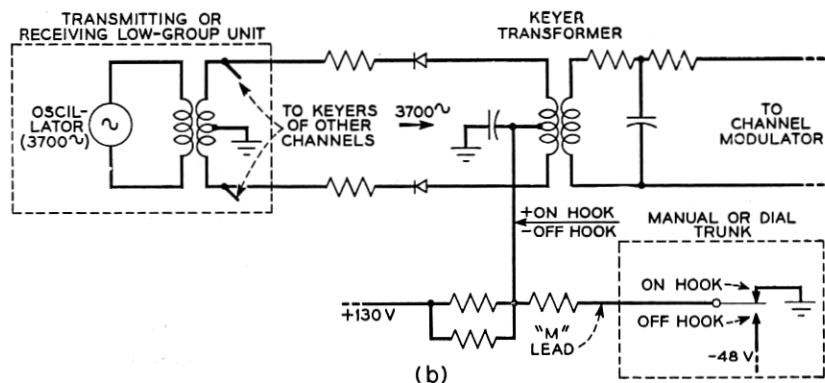
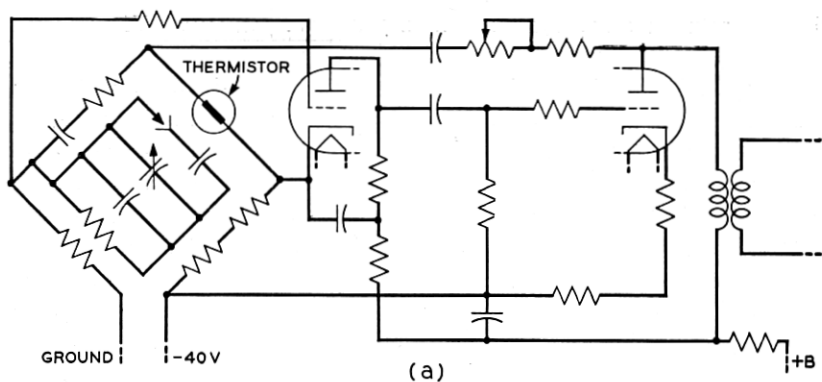

FIG. 6(a)—3700 cycle signaling tone oscillator circuit.

(b)—Channel signaling keyer circuit.

(c)—Channel signaling receiver circuit.

Such amplitude stabilization is needed to prevent excessive pulse distortion from the slow rise and fall of pulse edges in the delay circuit. Only during the transition periods between make and break can noises more than 7 db below normal signal level cause pulse distortion. The cathode follower supplies low impedance drive to the germanium rectifier which, with its low resistance load, results in highly stable operation. The delay circuit functions primarily to discriminate against short duration noise bursts during the off-hook signal condition. Unwanted relay operation at this time would flash the operator or cause registration of a wrong number. The output relay, which is of the mercury contact type, has a split winding for ease of adjusting the per cent break and to minimize pulse distortion with 130-volt battery variation. Bias change on the varistor rectifiers through the relay contacts prevents excessive first pulse distortion despite the high amount of delay used in the delay circuit. Control potentiometers in the circuit adjust "just operate" sensitivity, relay current and per cent break. On-hook and off-hook are sent from the signal receiver to the trunk circuit as open and ground, respectively, on the "E" lead.

Use of the N system as a part of the nationwide networks of dialing intertoll trunks imposes strict limits on the amount of pulse distortion contributed. The severest requirements are when operating into step-by-step offices where pulses distorted beyond per cent break limits of about 44-72 per cent may produce wrong numbers. A typical connection from a dial and outgoing trunk over a two-link N connection into a step-by-step office might be expected to have a distribution of pulse distortion as follows:

	Normal Battery and Normal System Levels (% Break)
Dial.....	63.5 ± 4%
Outgoing Trunk.....	-6 ± 2%
1st Type N Link.....	+1 ± 2%
Pulse Link.....	-1 ± 1.5%
2nd Type N Link.....	+1 ± 2%
	58.5 ± 11.5%

During extreme battery and level conditions on one N circuit link about ± 2% more pulse distortion can be expected.

CARRIER FREQUENCY TRANSMITTING AND RECEIVING CIRCUIT

The third part of the channel unit is the carrier subassembly. It contains a germanium varistor modulator and individual channel crystal carrier oscillator in the transmitting circuit and the channel band filter, an automatic gain control or channel regulator and a germanium varistor demodulator in the receiving circuit. Figs. 7(a) and 7(b) show the carrier

channel circuits. At the input of the transmitting circuit, the output of the compressor LPF and the signal keyer are connected. At the output all

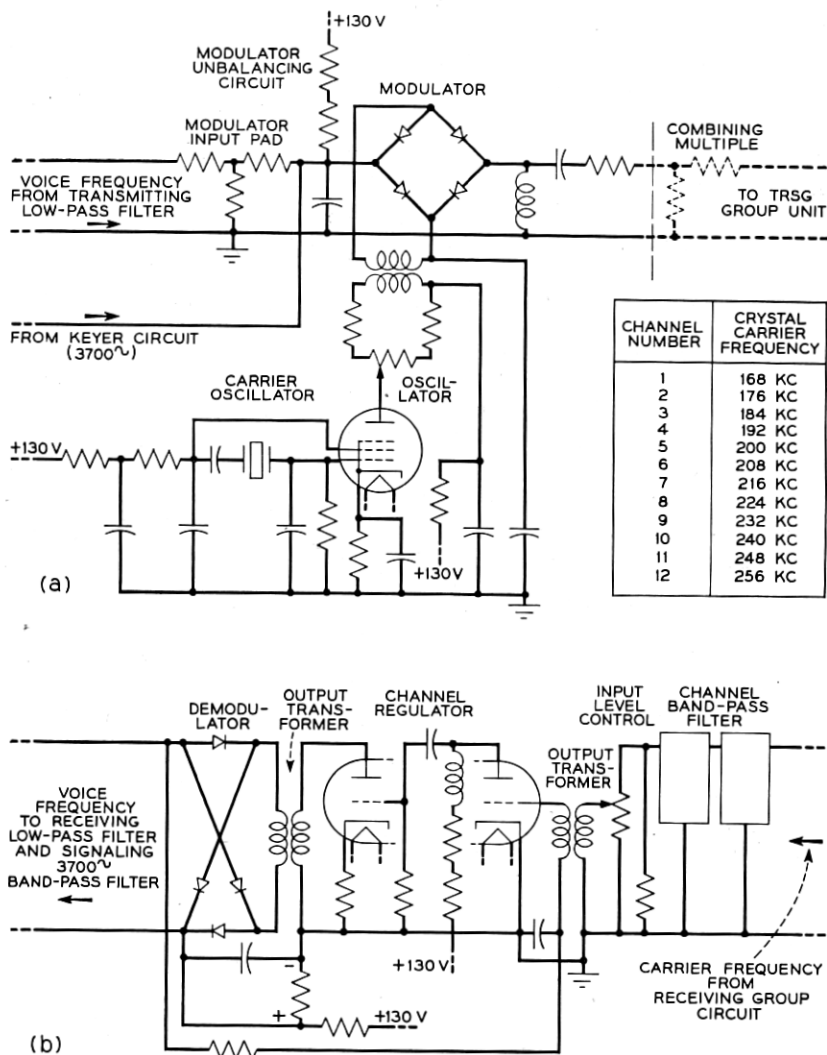

FIG. 7(a)—Channel carrier frequency transmitting circuit.

(b)—Channel carrier frequency receiving circuit.

modulators are connected together through pads individual to each channel and mounted on the terminal frame. The crystal oscillator uses a pentode tube arranged as a triode oscillator with electron coupling to the plate for

output. Because of the large spread between input and output signal bands, the balanced series modulator arrangement can use a simple condenser input and inductor output filter. Poor and uncontrolled carrier leak would result in change in amplitude and phase of the transmitted carrier used to regulate each channel in the receiving circuit and to demodulate the two sent sidebands of voice and signal frequencies. Selection of germanium units in manufacture provides good balance of the varistor bridge and results in very low level of carrier leak. A controlled amount of d-c. is introduced at the modulator input terminals from the 130-volt battery and sends carrier at adequate level and correct phase for demodulation of the speech sidebands in the demodulator without over modulation on the speech peaks. The transmitted carrier amplitude is stable for channel regulation purposes, varying in amplitude only with the 130-volt battery which, in most offices, will seldom be outside of one per cent limits.

In the receiving carrier channel the band filter at the input selects the particular channel from the receiving group unit output. The crystals in the oscillator and the band filters are the only differences among the 12 channels for this subassembly. The filter design is such that one or more channel units can be removed from service without affecting the performance of the others.

At the output of each band filter a potentiometer is used to adjust for the transmission inequalities from one channel to the next of the over-all system. The two-stage double-triode regulator automatically adjusts for any subsequent changes in level of the received channel signals. The regulator is operated by d-c. obtained from carrier rectification in the linear demodulator. Typical delayed AVC action is obtained by biasing out part of the rectified carrier voltage with a part of the 130-volt battery supply. The time constant of the regulator circuit is slowed to about 5 seconds to provide adequate regulating speed without false operation on speech or line hits. The demodulator is operated as a linear detector with highest peaks on speech sidebands just below 100% modulation. The unusually high impedance level of 10,000 ohms for the varistor demodulator provides large d-c. voltage for the gain control circuit without undue instability. This results from inclusion of the demodulator in the mu circuit of the regulator. The output of the demodulator is connected to the signaling band filter and the expander LPF.

TERMINAL TRANSMITTING AND RECEIVING GROUP UNITS

The group units serve essentially as terminal repeaters for transmitting and receiving directions. There are four varieties: low-group transmitting (LGT) and associated high-group receiving units (HGR) or high-group transmitting (HGT) and associated low-group receiving units (LGR). A

terminal uses three plug-in subassemblies: the low group unit, the high group unit, and the oscillator unit containing 304 kc and 3700 cycle signaling oscillators. The oscillator unit is always associated with the low-group unit.

In Fig. 8, (a), (b) and (c), typical group unit circuits are shown. The 12 channels combine in the resistance pads of the multiple on the terminal frame and enter the transmitting group unit through the E filter. This filter, as previously described, is used in both types of transmitting units to suppress transmission on harmonics of the channel carrier frequencies. The noise generator at the input terminals supplies tube noise of equal amplitude at each high-group channel frequency to mask intelligible crosstalk in short-toll or exchange circuits where the system noise may be low and the crosstalk disturbing. A potentiometer controls the noise magnitude, which is always set well below the tolerable limit. A slope equalizer in the high band is used in the transmitting group unit to produce a compromise slope among the channels at repeater points. Through its use input and output levels of low-high and high-low repeaters are sloped either positively or negatively by about 7 db, so that no one channel has more than 7 db disadvantage from a noise and modulation standpoint. A compensating slope equalizer in the receiving group unit restores the channels to flat band at its output. The group modulator and 304 kc oscillator are alike in group units and repeaters, whether used for low- to high-group band translation or vice versa. The crystal oscillator differs only in minor respects from the channel unit oscillator. The modulator is a double balanced ring type using four $\frac{3}{16}$ inch diameter copper oxide discs. Group and repeater modulators employ copper oxide to minimize noise. Low signal levels and high carrier level are used in the group modulators to produce low interchannel modulation. As a result good balance in the modulator and an output filter are needed to suppress carrier leak. The two-stage feedback amplifier is alike in repeaters and group units except in minor respects.

REPEATER

A block schematic of a repeater station is shown in Fig. 9. The plug-in repeater is shown within the dashed vertical lines. Mounted on the frame and permanently wired are span pads, artificial line sections and deviation equalizers when needed. The deviation equalizer is used only at low-group frequencies and is placed in repeater input or output, whichever results in locating the equalizer in an office instead of a pole cabinet. Resistance span pads in 2 db steps from 2 db to 24 db are used to build out line sections shorter than 8 miles at channel 1 frequency to 46 db loss in the low group and 50 db in the high group. For line sections shorter than four miles, artificial cable sections in two-mile and four-mile sizes are available. In

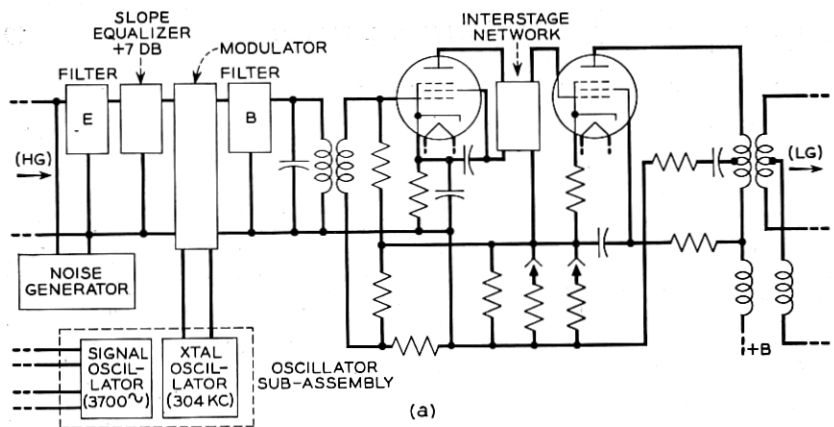

(a)

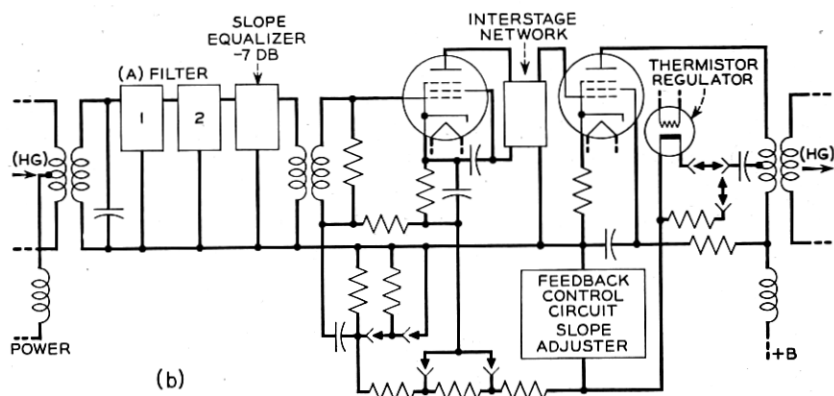

(b)

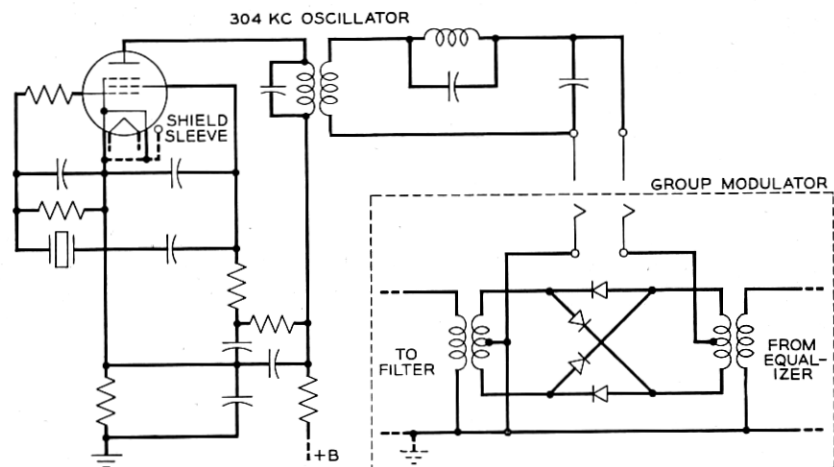

(c)

FIG. 8(a)—Terminal low group transmitter.
 (b)—Terminal high group transmitter.
 (c)—Group modulator and 304 KC oscillator circuit

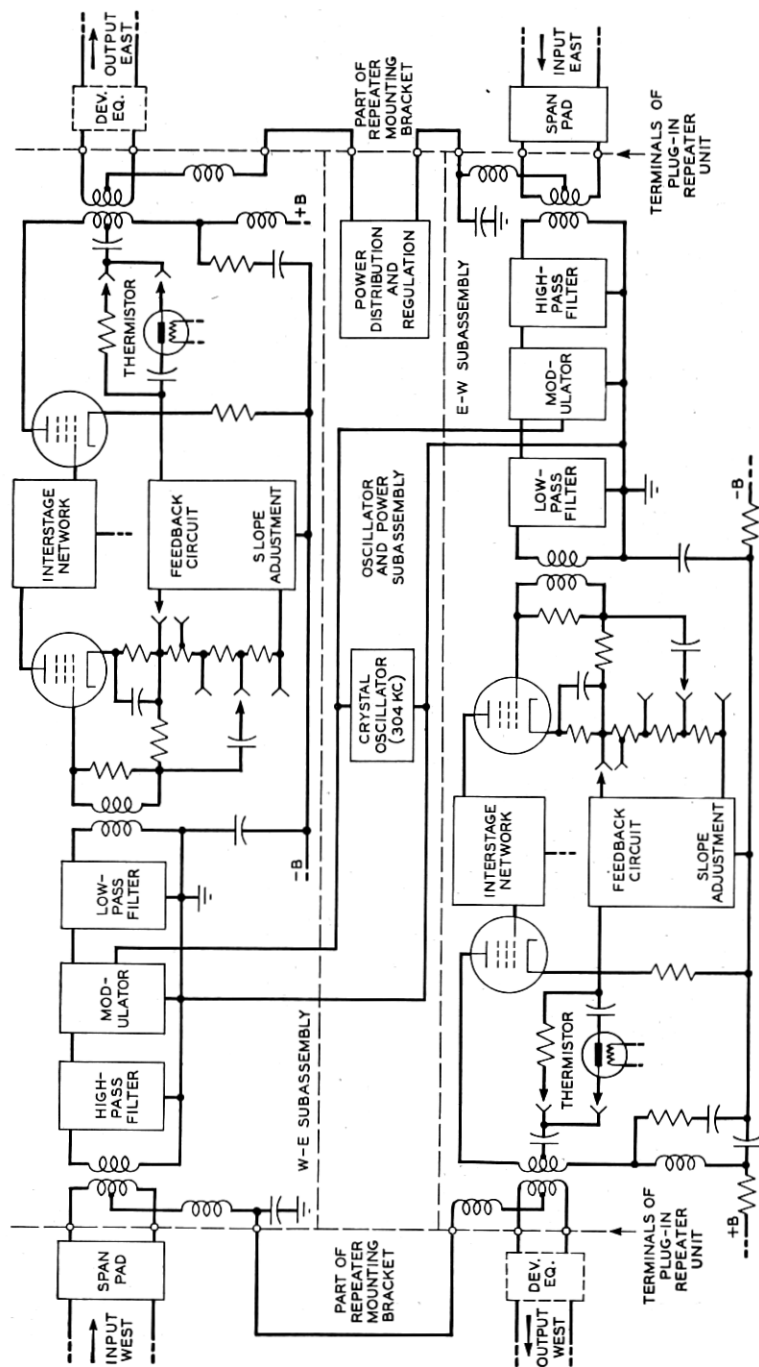

FIG. 9—N-1 Repeater block schematic.

most cases very little or no span pad would be used and only in rare cases would the artificial line sections be needed. The small amount of slope needed to supplement the span pad loss is provided in a three-step repeater slope control. A total of about seven db of slope range within about 1 db accuracy is available in two successive repeaters. This would permit compensation for about three miles of inequality in successive line sections. The slope changes are produced by switching simple networks in the amplifier feedback circuit.

The plug-in repeater consists of three separate subassemblies connected together through the multicontact plug and jack connectors used in all N equipment units. Of these the east-west and west-east modulator-amplifier units are alike electrically and mirror images mechanically. The oscillator-power subassembly forms the third subassembly. These units are alike in LH and HL repeaters. The amplifier-modulator circuits supply the transmission paths through the repeater and differ between LH and HL repeaters only in whether the input circuit accepts low-band frequencies and amplifies high-group frequencies at the output or the reverse. The input A or C filter blocks near-end crosstalk from line frequencies within the same quad, which would overload and produce interchannel interference within the same system, or it blocks interaction crosstalk through tertiary-voice pairs from other systems in the cable. The output B or D filter suppresses 304 kc carrier leak and the unwanted upper sideband on the 304 kc carrier of the input group frequency band.

In addition to the slope control two additional controls are used in the feedback circuit of the repeater amplifier. Resistance strapping options made in the factor adjust each manufactured repeater to a nominal gain of 48 db to an accuracy of 1 db. A second control of flat gain is obtained from a thermistor directly heated by a fraction of the total repeater output power. Inasmuch as the signal tone power, when present in a channel, is about 12 db below the channel carrier power, and the speech of an average talker about 15 db below the power of the carrier, the total output power is almost entirely carrier. As the line changes in attenuation with temperature, the change in the strength of the carriers at the repeater output supplies more or less heat to the thermistor pellet. An increase in heat due to decreased line loss at cold temperatures causes the thermistor resistance to decrease and produce more amplifier feedback and less repeater gain, thus offsetting the change in line loss. The normal operating range of the thermistor resistance is from about 1000 to 20,000 ohms. At nominal gain of 48 db the resistance will always be about 9000 ohms. Each pellet is controlled in manufacture to have its nominal resistance value for a specified amount of repeater output power. The temperature at which the pellet operates for the standard repeater output power would vary appreciably

except for provision of an ambient temperature compensating circuit. This circuit consists of a heater electrically insulated from the pellet and controlled by a disc thermistor at the repeater temperature. As the repeater temperatures decreases, the disc thermistor increases its resistance, allowing more current to flow into the heater winding. The thermistor pellet is

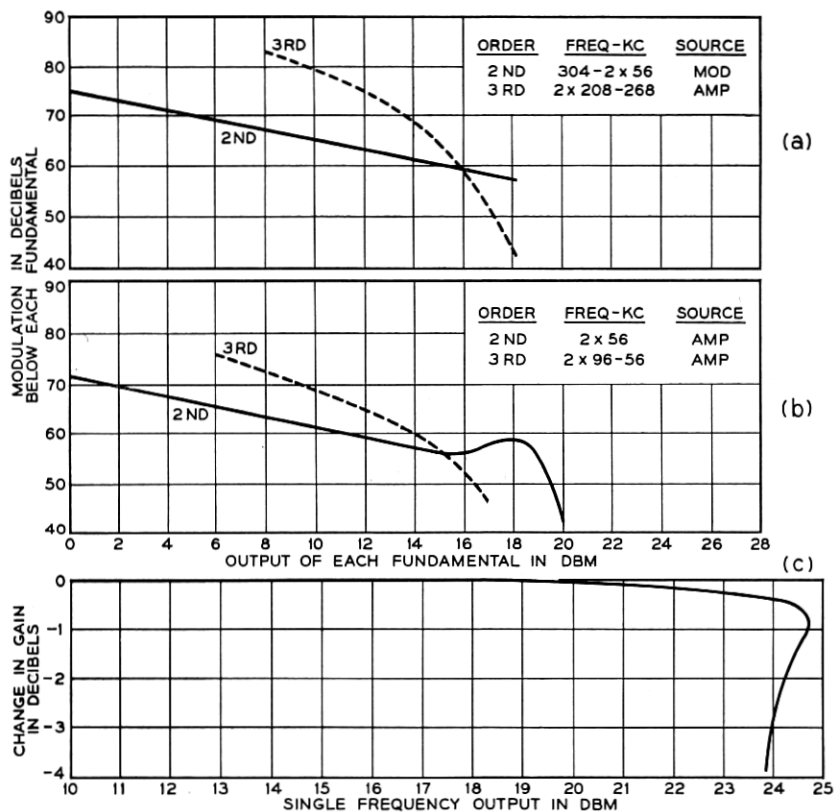

Fig. 10(a)—Low-high repeater modulation.

(b)—High-low repeater modulation.

(c)—Gain-load characteristics of high-low and low-high repeaters.

maintained at a nominal or thermostated temperature which, in general, is from about 135° to 185°F. This allows operation of the regulator with repeater temperatures from about -20°F to 130°F with little change in its control range. Beyond these temperatures the performance deteriorates slowly.

The low level operation of the modulator and repeater amplifier combined with the high level of carrier in the modulator and large amplifier feedback, result in low interchannel modulation. In Fig. 10, (a) and (b), one- and two-

frequency modulation curves are shown. Figure 10(c) shows the single-frequency load characteristic. Most of the modulation crosstalk results from the many third-order combinations of carriers and speech sidebands in a repeater. Third-order products of this type add in phase in a string of repeaters. Twenty repeaters are 26 db worse in modulation crosstalk than one repeater.

REPEATER AND TERMINAL LEVELS

The operating levels of the system are all referred to the strengths of the individual carriers which are each made 15 db above one milliwatt (+15 dbm) at reference 0 level of one sideband. Thus, a +5 dbm signal at 0 level

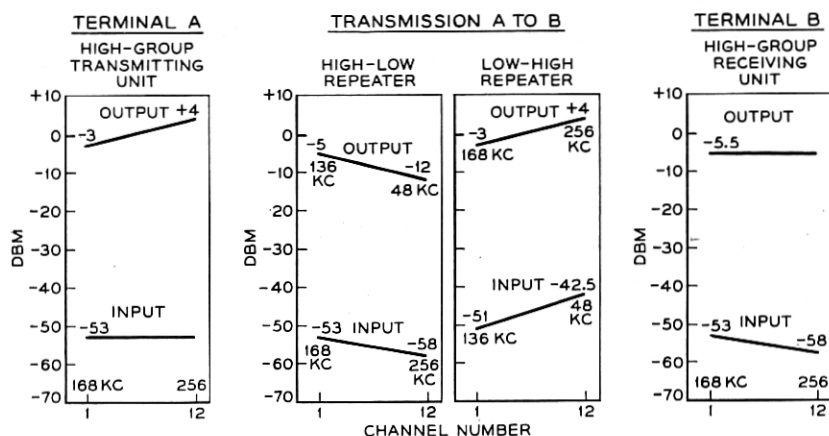

FIG. 11(a)—N-1 repeater and group unit level diagrams.

in the voice circuit is modulated to produce two sidebands each of +5 dbm at 0 single sideband level in the carrier part of the system.

Six db of loss must be inserted between 0 single sideband level and 0 voice level at the output because of the in-phase addition of the two sidebands upon demodulation. Thus, the two +5 dbm sidebands become +5 dbm at 0 voice level in the output. Zero dbm of 3700 cycle tone is used for signaling at 0 level and, since it is inserted after the compressor and removed before the expander, each sideband is 15 db below the carrier. Limiting of speech peaks in the compressor restricts maximum values to about +9 dbm at 0 level. In-phase addition of the maximum speech sideband peaks nearly 100% modulate the carrier (+15 dbm at 0 level).

In Fig. 11, (a) and (b), carrier level information is given for repeaters and terminals. High-group output repeaters and terminals have carrier outputs sloped from -3 to +4 dbm with a total of +12 dbm of carrier

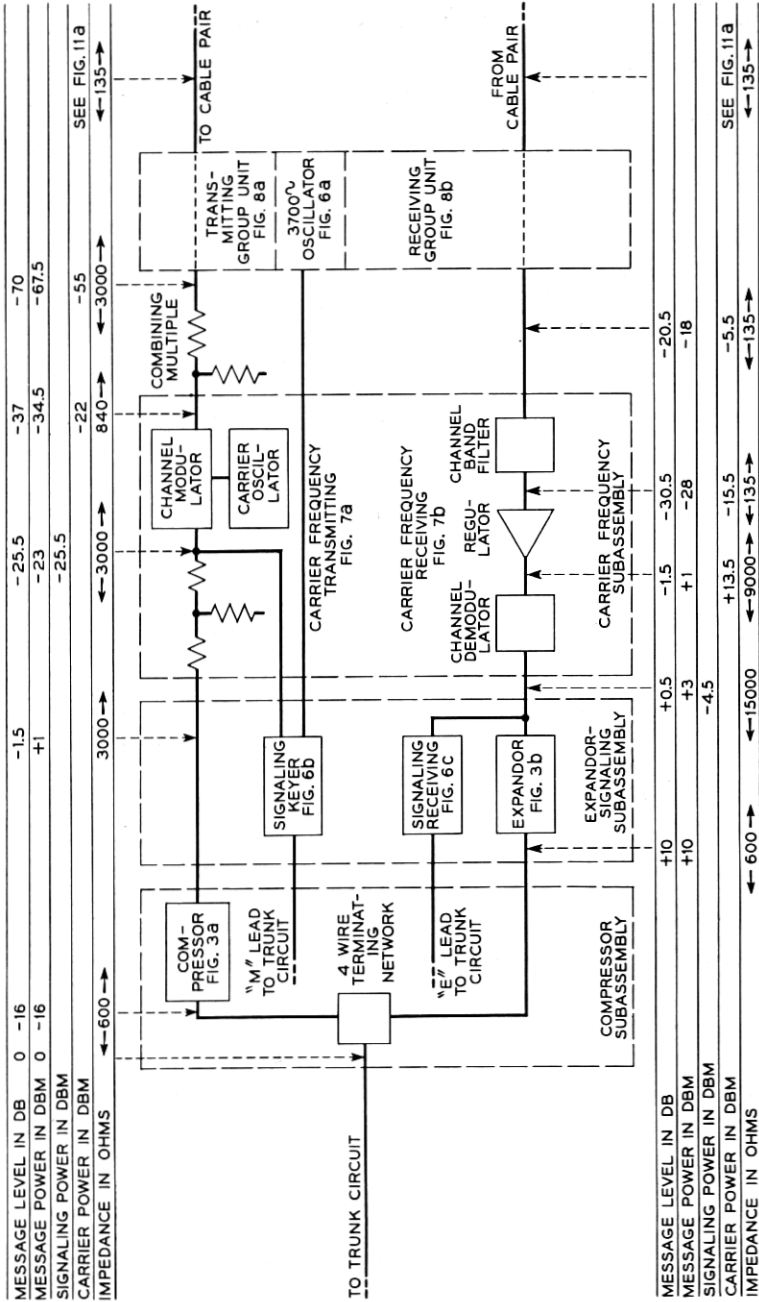

Fig. 11(b)—N-1 channel unit simplified schematic and level diagram.

power. Low-group output repeaters and terminals have carrier outputs sloped from -12 to -5 dbm with total carrier power of $+3$ dbm. Transmitting group input carrier levels of -53 dbm and receiving group output carrier levels of -5.5 dbm are alike in low-and high-group terminal units.

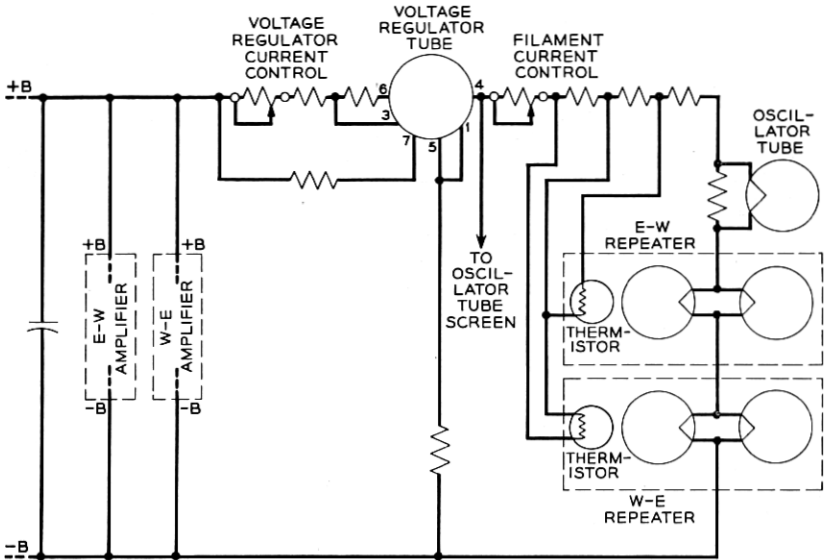

FIG. 12—Repeater power regulator—Distributer Circuit.

Strengths of signals at various levels before and after the compressor can be simply calculated from the following equation:

$$P_c = \frac{P - L}{2} + L_c + 2.5,$$

where P and L are the power in dbm and level in db before the compressor and P_c and L_c the corresponding values after the compressor.

POWER SUPPLY

The power supply at terminals is obtained from $+130$ volt and -48 volt batteries. All vacuum tubes have 20-volt heaters used two in series across an adjusted 40 volts from the 48-volt battery. Repeaters are supplied either locally from $+130$ volt battery or over the simplexes of the cable quad to pole-mounted points using $+130$ volt and -130 volt battery. A series parallel arrangement of tube and thermistor heaters in the repeater obtain closely regulated voltage from a gas tube control circuit. This arrangement is shown in Fig. 12(a). So closely are the tube heater voltage and

current held despite changes in supply voltage, cable conductor resistance and tube space current, that the heater voltage and current can be adjusted

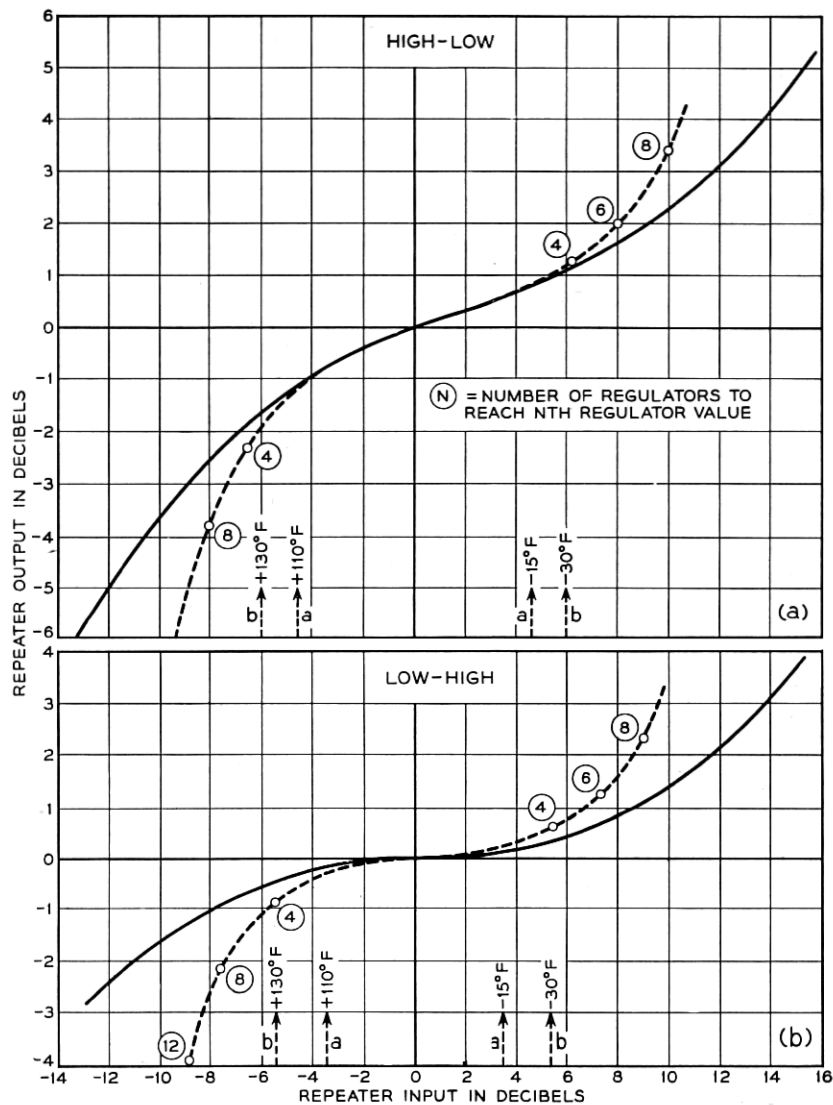

FIG. 13—Regulation characteristics of high-low and low-high repeaters.

to values below those used in telephone offices. As a result an appreciable increase in tube life is obtained compared to that obtained in offices under ordinarily regulated battery conditions.

SYSTEM REGULATION

The regulating characteristics of the LH and HL repeaters are shown in Fig. 13, (a) and (b). The channel unit regulating characteristic is shown in Fig. 14. The solid curves in Fig. 13, (a) and (b), show change in repeater

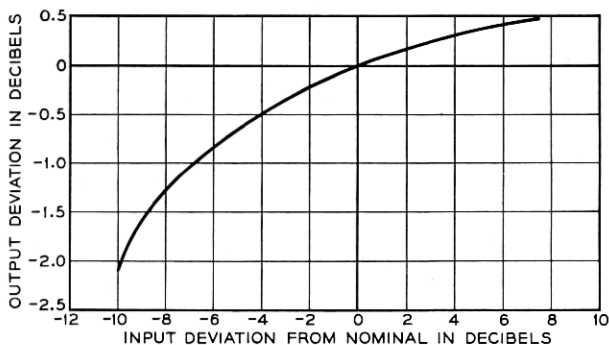

FIG. 14—Regulation characteristic of channel unit regulator.

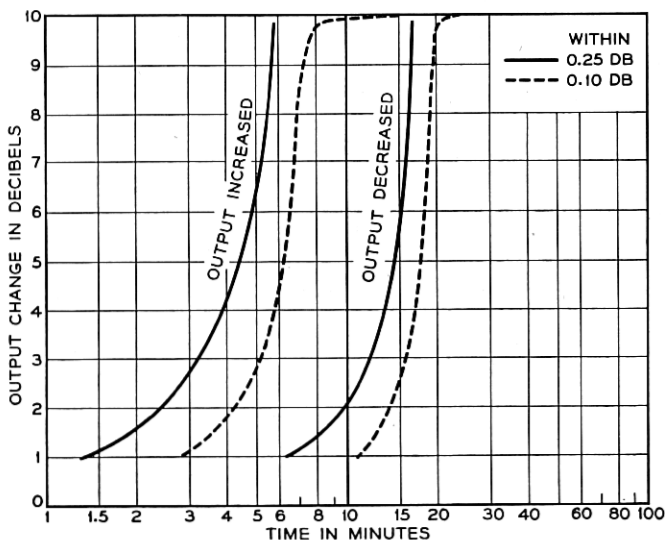

FIG. 15—Stabilization time of repeater or group unit regulator.

output when the total carrier input power is subjected to flat gain line changes as shown by the abscissa. The dotted curves show the regulation of a long string of repeaters, each regulating for the same line change, as well as for the residual output change passed on into successive line sections. The circled numbers indicate the number of the repeater at which the output will depart no further at the indicated input regardless of how many follow-

ing repeaters there may be. The arrows at "a" and "b" show the line change expected for extreme ranges of ambient temperature for 8 miles of 19-gauge toll cable. The group terminal regulators have characteristics about like those of the HL repeater. It can be seen that it would take a most extraordinary set of line conditions to require the channel regulator to compensate for as much as ± 5 db change at its input. Despite the doubling of

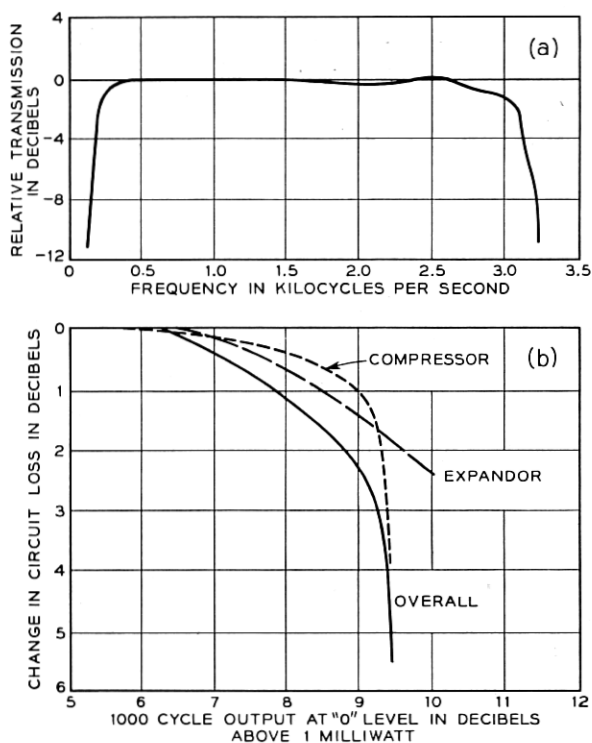

FIG. 16(a)—Typical channel net loss frequency characteristic.
(b)—Typical channel limiting characteristics.

circuit variations by the expander circuit, Fig. 14 indicates that the overall channel net loss can be expected to stay within about ± 2 db.

Figure 15 shows the speed with which the thermistor regulator in the repeater restores the output to normal when subjected to a line change. An increase of input from the line of 6.5 db, for example, requires a 5-minute wait for the output to get within .25 db of its final value. The regulator operates more slowly on decreasing line input. It is essential that the regulator move rather slowly to avoid false regulation on accidental short-duration line hits.

OVER-ALL SYSTEM PERFORMANCE

Various means are used to describe the over-all performance of a carrier system such as type N. Subjective tests show, as in other carrier systems, that noticeable deterioration in speech quality occurs when many links are connected in tandem. Satisfactory conversation has been carried on between Milwaukee and Madison, Wisconsin over nine such links, representing a total circuit length of about 750 miles. In this circuit connection, speech passed through 9 compandors, 108 group repeaters and 117 stages of modulation. Practically all of the speech impairment occurred in the 9 compandors.

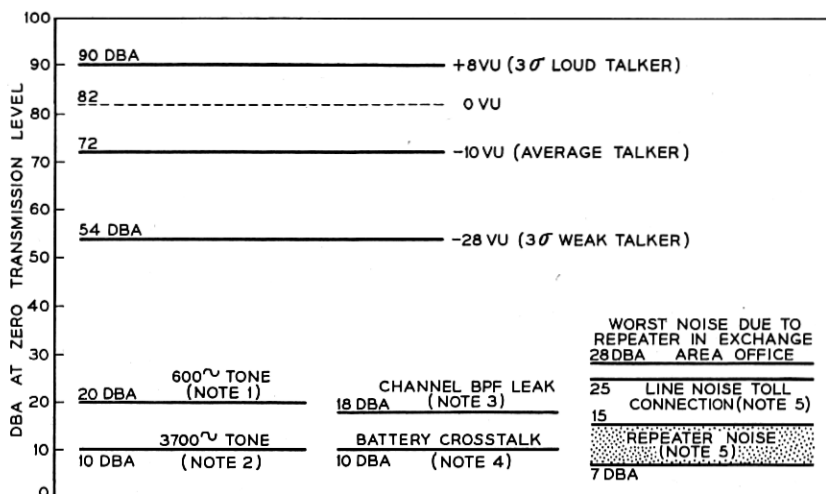

— NOTES —

1. BEATS BETWEEN LISTENING CHANNEL SIGNALING TONE AND THAT ON ADJACENT CHANNEL.
2. SIGNALING TONE ON LISTENING CHANNEL.
3. +4VU INTERFERING TALKER.
4. +4VU INTERFERING TALKER, FAR END.
5. 10-REPEATER SYSTEM

FIG. 17—Relative levels of speech and interference on N-1 carrier.

When only six links were used (which is about the maximum likely to be encountered in service) little impairment was observed. Generally even a critical observer cannot distinguish between a single N channel link and a direct circuit connection between the transmitter and the receiver of the same noise and bandwidth. In Fig. 16, (a) and (b), the frequency characteristic and limiting characteristic of the channel are shown. The useful band of speech frequencies passed is considered to be between 10 db points in four links or about 200 cycles to 3100 cycles. In the N system, because the compandor control circuits are particularly wide-band, the frequency responses are substantially alike when measured with single frequencies or when actuated by speech.

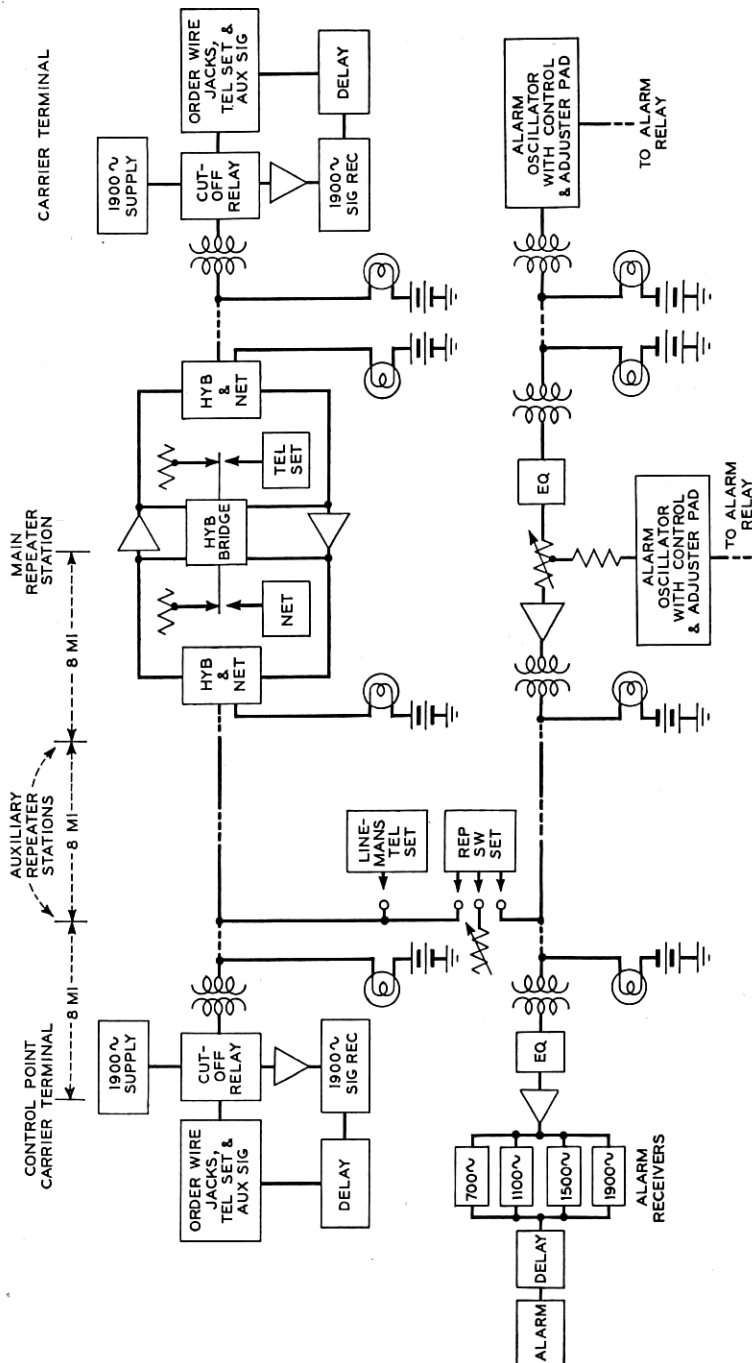

Fig. 18—N-1 order wire and alarm block schematic.

Noise and crosstalk in the over-all system come from many causes. Figure 17 shows relative levels of principal contributions.

ORDER WIRE AND ALARM CIRCUIT

Two spare pairs in the cable along an N carrier route are provided for testing and maintenance purposes. One pair, either 16- or 19-gauge with B88 or H172 loading, is used for order wire. Signaling uses either 1900 cycles or 1000-20 ringing. A cableman's whistle is used at pole repeaters to signal attended points. A second pair of conductors is used to bring alarms to attended points from unattended repeater power points. Tones at 700, 1100, 1500 or 1900 cycles are provided for alarming four separate points. Tone is normally on the line and is removed by a relay during a trouble. A 5-second delay in the alarm circuit prevents false operation on line hits. D-C. power is simplexed over the alarm and order wire pairs to pole repeaters as a power source for switching in a spare repeater. Figure 18 shows the order wire and alarm circuit arrangement.

REFERENCES

1. "Improved Three-Channel Carrier Telephone System," J. T. O'Leary, E. C. Blessing and J. W. Beyer, *Bell Sys. Tech. Jour.*, Jan. 1939.
2. "New Single Channel Carrier Telephone System," H. J. Fisher, M. L. Almquist and R. H. Mills, *A.I.E.E. Trans.* 57, 25, (1938); also *Bell Sys. Tech. Jour.*, Jan. 1938.
3. "Twelve Channel Carrier Telephone System for Open Wire Lines," B. W. Kendall and H. A. Affel, *A.I.E.E. Trans.* 58, 351 (1939); also *Bell Sys. Tech. Jour.*, Jan. 1939.
4. "Some Applications of the Type J. Carrier System," L. C. Starbird and J. D. Mathis, *A.I.E.E. Trans.* 58, 666 (1939); also *Bell Sys. Tech. Jour.*, Apr. 1939.
5. "Carrier Telephone System for Toll Cables," C. W. Green and E. I. Green, *Electrical Engineering*, 57, 227 (1938); also *Bell Sys. Tech. Jour.*, Jan. 1938.
6. "Cable Carrier Telephone Terminals," R. W. Chesnut, L. M. Ilgenfritz and A. Kenner, *Electrical Engineering*, 57, 237 (1938); also *Bell Sys. Tech. Jour.*, Jan. 1938.
7. "Crosstalk and Noise Features of Cable Carrier Telephone Systems," M. A. Weaver, R. S. Tucker and P. S. Darnell, *Electrical Engineering*, 57, 251 (1938); also *Bell Sys. Tech. Jour.*, Jan. 1938.
8. "Experience in Applying Carrier Telephone Systems to Toll Cables," W. B. Bedell, G. B. Ransom and W. A. Stevens, *Bell Sys. Tech. Jour.*, Oct. 1939.
9. "An Improved Cable Carrier System," H. S. Black and others, *A.I.E.E. Trans.*, 66, 741 (1947).
10. "A Million-cycle Telephone System," M. E. Strieby, *Bell Sys. Tech. Jour.*, Jan. 1937.
11. "Frequency-Division Techniques for a Coaxial Cable Network," R. E. Crane and others, *A.I.E.E. Trans.*, 66, 1451 (1947).
12. "Progress in Coaxial Telephone and Television Systems," L. G. Abraham, *A.I.E.E. Trans.*, 67, 1520 (1948).
13. "Stability of Tandem Regulators with L-1 Carrier Systems," J. P. Kinzer, *A.I.E.E. Trans.* 68 (pt. 2), 1179 (1949).
14. "Attenuation and Delay Equalization for Coaxial Lines," W. R. Lundry, *A.I.E.E. Trans.* 68 (pt. 2), 1174 (1949).
15. "Equalization of Coaxial Lines," K. E. Gould, *A.I.E.E. Trans.* 68 (pt. 2) 1187 (1949).
16. "Carrier Telephone System for Rural Service," J. M. Barstow, *A.I.E.E. Trans.* 66, 501 (1947).
17. "Application of Rural Carrier Telephone System," E. H. Bartelink and others, *A.I.E.E. Trans.* 66, 511 (1947).