

Extensions to the Theory and Design of Electric Wave-Filters

By OTTO J. ZOBEL

The problem of terminal wave-filter impedance characteristics is considered in this paper, in particular that of obtaining an approximately constant wave-filter impedance in the transmitting bands of a wave-filter of any class, which is of importance where the wave-filter is terminated by a constant resistance, the usual case. The solution obtained is based upon the repeated use of the methods of deriving wave-filter structures which gave the *M*-types, combined with composite wave-filter principles. The results are wave-filter transducers which at one end have standard "constant *k*" image impedances and at the other have image impedances which can theoretically be made constant in the transmitting bands to any degree of approximation desired. Practical fixed structures are shown.

Parts I and II give this derivation and composition of wave-filter structures. Two allied subjects, respectively, the designs of networks which simulate the impedances of wave-filters, and of loaded lines, are dealt with in Parts III and IV, such designs making use of the previous results.

The four Appendices contain new reactance and wave-filter frequency theorems, particular fixed transducer designs and certain equivalents; also, a chart for determining terminal losses at the junction of such a fixed wave-filter transducer and a resistance termination. This chart supplements those previously given in a chart method of calculating wave-filter transmission losses.

INTRODUCTION

ONE important problem which frequently arises in wave-filter design is that of obtaining a terminal wave-filter impedance which is approximately a constant resistance at all frequencies in the transmitting bands. This ideal impedance characteristic is desirable where a wave-filter is terminated by such a constant resistance, as is usually the case. Under these ideal conditions, for frequencies in the transmitting bands all terminal reflection losses are avoided, and there are no impedance irregularities at the terminal junction to be reflected back through the wave-filter and produce objectionable impedance irregularities at the other end.

The design of ladder type wave-filters of any class,¹ regarded from either the theoretical or the practical standpoint, involves taking into consideration two standard image impedances; and the internal or main part of a composite wave-filter structure, called the mid-part, usually has the equivalent of one or the other of these image impedances at each terminal. These two standard image impedances are the image

¹"Theory and Design of Uniform and Composite Electric Wave-Filters," O. J. Zobel, *B. S. T. J.*, January, 1923.

impedances² at the two mid-points, mid-series and mid-shunt, of the "constant k " wave-filter of that class. As defined in the first paper referred to, a "constant k " wave-filter is a reactance network of ladder type, the product of whose series and shunt impedances is $k^2 = R^2$, a constant independent of frequency, where k has the significance of being the impedance of the corresponding uniform line. It is well known that these standard, or "constant k ," image impedances vary greatly with frequency over all the transmitting bands and are therefore far from satisfactory as terminal wave-filter impedances. What is needed at a terminal having such an image impedance is a terminal wave-filter transducer of the same class which at one end can be joined without impedance irregularity to the standard termination and which at the other end has a desirable terminal image impedance. Actually, this amounts to terminating a composite wave-filter in a section which has at the final terminals the image impedance desired. We may set up the ideal for this purpose as follows:

The ideal terminal wave-filter transducer of any class is a dissymmetrical wave-filter network having at one end an image impedance equal at all frequencies to the standard mid-series or mid-shunt image impedance of the "constant k " wave-filter and at the other end an image impedance which has approximately the same constant resistance value ($k = R$) at all frequencies in the transmitting bands.

While the principal function of such a transducer is to furnish the desired terminal image impedance, its wave-filter propagation characteristics would also be useful.

The first approximate solution previously obtained was by means of M -type wave-filter terminations;³ that is, the terminal transducer in this case was a single mid-half section of an M -type wave-filter whose parameter m is in the neighborhood of $m = .6$. Such a section has at one end one of the two standard image impedances referred to above for all frequencies. At the other end its image impedance has the same constant resistance value within about 4 per cent over 86 per cent of every transmitting band and this has proved to be quite satisfactory for many designs. However, later design requirements, such as those for certain low pass and high pass wave-filters in carrier systems, have demanded, principally from an impedance irregularity standpoint, that the resistance terminal characteristic be more nearly constant and extend still farther toward the critical frequencies than is possible with M -type terminations so as to include in this manner a larger part of the

² "Transmission Characteristics of Electric Wave-Filters," O. J. Zobel, *B. S. T. J.*, October, 1924.

³ See page 17 of paper in footnote 1.

transmitting bands. A study of this general problem has recently been made, the results of which were presented in two papers both of which appeared in the same issue of this *Journal*.⁴ The terminal transducers there described consist of simple non-uniform ladder type structures whose series and shunt impedances are each arbitrarily proportional to the corresponding impedances of the "constant k " wave-filter and of two-terminal reactance networks added in series or in shunt at the terminating end to complete them. A transducer of this kind practically satisfies the ideal conditions in the transmitting bands, but it does not have a standard image impedance in the attenuating bands as is desired here. Because of the latter fact, transmission loss calculations can not be made as readily as in a composite wave-filter.

This paper gives the solution of the terminal wave-filter impedance problem by the logical extension of the use of the general systematic methods of derivation which had led to the derivation of M -type sections, and the use of composite wave-filter principles. The solution is obtained in two naturally related steps which are, first, the derivation of sections having mid-point image impedances which are desirable as terminal wave-filter impedances and, second, the formation of terminal wave-filter transducers having these image impedances at terminals. A brief outline of these steps will be given here before proceeding with the details.

The first step, the derivation of suitable terminal sections, is based upon the use of two fundamental operations for deriving structures already mentioned which are applicable to any ladder type network. One of these, *the mid-series derivation* whose operation will be designated symbolically as $D_1(s)$, derives from any prototype a more general ladder type structure whose series and shunt impedances are such functions of the prototype impedances and of an arbitrary parameter, s , that its mid-series image impedance is identical with that of the prototype and thus independent of s . Its mid-shunt image impedance is, however, a function of this arbitrary parameter, where $0 < s \leq 1$, and is thus more general than that of the prototype at the corresponding termination. The other operation, *the mid-shunt derivation* designated as $D_2(s)$, derives from a prototype another more general structure whose mid-shunt image impedance is identical with that of the prototype but whose mid-series image impedance depends upon s . If both of these prototypes, not necessarily the same, have identical transfer constants, then both derived structures having the same value of

⁴ "A Method of Impedance Correction," H. W. Bode, *B. S. T. J.*, October, 1930. "Impedance Correction of Wave-Filters," E. B. Payne, *B. S. T. J.*, October, 1930.

s will also have identical transfer constants which are functions of s . At the limiting value of the parameter, $s = 1$, each derived structure becomes identical with its prototype. The reason for the use of s as the general parameter instead of m , as in previous papers, is to permit it to take on without confusion a succession of values including m , as will be seen.

Beginning with the "constant k " wave-filter of any class as the initial prototype, these two operations are performed alternately on successive structures, which results in producing two different sequences of wave-filter structures, depending upon which of the operations is first used. These wave-filters are all of the same class and contain successively more and more elements. In Sequence 1 (see Fig. 4) the first operation is $D_1(m)$, then $D_2(m')$, $D_1(m'')$, etc., the parameters being taken in succession as $s = m, m', m'',$ etc. In Sequence 2 (see Fig. 5) the first operation is $D_2(m)$, then $D_1(m')$, $D_2(m'')$, etc., with the same succession of parameters as before. Since at each derivation another single parameter is introduced, each successive structure of either sequence has one more arbitrary parameter than the preceding structure and the number of arbitrary parameters in any structure is equal to the number of alternate operations performed to obtain it from the "constant k " wave-filter. Now every section has one mid-point image impedance which is a function of all of its arbitrary parameters. Hence, this whole process is effectively one for obtaining a structure with an image impedance which contains any desired number of arbitrary parameters. The first derived structures in both sequences are the pair called M -types having the parameter m . The second derived ones will be called the pair of MM' -types with parameters m and m' ; the third, the pair of $MM'M''$ -types with m, m' and m'' ; etc. Each successive pair can have a more nearly constant resistance impedance in all transmitting bands than the preceding pair because of one additional parameter in the image impedance functions. The two members of a pair have identical transfer constants and either member can be obtained from the other, as inverse networks of impedance product R^2 .

While the derived structures are wave-filters having the same transmitting bands as the "constant k " wave-filter, their propagation characteristics are otherwise more general. However, no different propagation characteristics are obtained in the successively derived structures than are possible with the first derived or M -types since all these derived structures have potentially identical transfer constants, the transfer constant of any structure being dependent upon its parameters only in their product. A simple relation is given here between these parameters, the frequencies of infinite attenuation

and the critical frequencies belonging to any of these derived sections; there is a slightly different relation for each of the four general groups into which all the different classes of multiple band pass wave-filters may be divided. The MM' -types, etc., are structurally more complicated than M -types and therefore have preferential value from an impedance standpoint primarily.

The second step of this solution, the formation of terminal wave-filter transducers, is related to the first step. The method of deriving sections which possess desirable terminal image impedances furnishes through the successive operations the necessary means whereby the final impedance section can be joined to the standard "constant k " wave-filter without impedance irregularity. There are two such general transducers, the series terminal transducer which connects to the standard mid-series image impedance and the shunt terminal transducer which connects to the standard mid-shunt image impedance. Obviously the *series terminal transducer* is obtained from the wave-filters of Sequence 1 and is formed by connecting in tandem mid-half sections of successive derived structures, beginning with the series M -type and ending in the one having the desired image impedance. At each junction point, always between dissimilar sections, the image impedances are identical and in every case it is possible to merge the adjacent series or shunt impedances, thereby considerably reducing the total number of elements in the entire network. This composite wave-filter has the same number of dissimilar mid-half sections as there are arbitrary parameters in the final image impedance function and the sections are functions of one or more of these same parameters, containing in succession m , m and m' , m and m' and m'' , etc., the final terminal section containing all parameters. The image impedance at one end of this transducer is entirely independent of all these parameters, being equal at any frequency to the mid-series image impedance of the standard "constant k " wave-filter; that at the other end depends upon them all. Fixing the final impedance characteristic determines all these arbitrary parameters and therefore all the sections making up the transducer. The propagation characteristics of these sections, while similar in form, are all different in frequency placement, being like those of M -types having successive parameters equal to the products m , mm' , $mm'm''$, etc. Since m , m' , m'' , etc., are each less than unity, these products form a decreasing sequence. As a result, the attenuation peaks of successive sections are progressively nearer the critical frequencies and their combination builds up desirable attenuation characteristics.

The *shunt terminal transducer* is obtained in an exactly similar

manner, but uses the wave-filters of Sequence 2 and begins with the shunt M -type.

Any pair of these transducers having the same number and values of the parameters have identical transfer constants; moreover, either network might be obtained from the other, as inverse networks of impedance product R^2 .

Theoretically, with dissipation neglected, the solution of the terminal wave-filter impedance problem, as outlined above, can be carried to any degree of approximation desired toward a constant resistance terminal image impedance in all transmitting bands. Practically, however, it is here found unnecessary to go beyond the MM' -types which follow in sequence directly after the well-known M -types and are thus comparatively simple extensions. They meet the desired impedance ideal well and are in this respect a considerable improvement over the M -types just as the latter are an improvement over the "constant k " wave-filter, as we might expect. By a proper choice of the parameters m and m' it will be shown later that the MM' -types can be made to have image impedances which are equal to the same constant resistance within 2 per cent over the greater part of all transmitting bands. In low pass and band pass wave-filters this nearly constant resistance extends over a frequency range which is approximately equal to 96 per cent of the theoretical band width. Similar characteristics apply to wave-filters of other classes. Such a range includes all of a transmitting band except a small region next to each critical frequency where, however, the wave-filter attenuation makes it practically useless for transmitting purposes. Each terminal transducer would then be a composite wave-filter made up of a mid-half section of the associated M -type of parameter m and a mid-half section of such an MM' -type of parameters m and m' . While, as already stated, the M -types and MM' -types have potentially the same propagation characteristics, the particular values of the parameters m and m' chosen from the impedance standpoint give attenuation peaks which in these M -types are farther away from the critical frequencies, and in these MM' -types nearer, than in an M -type of parameter $m = .6$, which is generally desirable. Two such fixed designs⁵ are given here for connection to the "constant k " wave-filter of any class at mid-series or at mid-shunt, respectively. The particular forms these take

⁵ The reader should keep in mind that such a terminal wave-filter network is itself a true composite wave-filter of the same class as the standard or "constant k " wave-filter. Its image impedance at one end is the same as a mid-point image impedance of the standard, while that at the other end is the mid-point image impedance of the MM' -type which is desired at the terminal.

in the four most important specific classes, namely, low pass, high pass, low-and-high pass and band pass, are also shown.

Finally, two by-products obtained from a further use of these fixed network designs will be added. One is the ready design of networks to simulate the mid-point image impedances of "constant k " wave-filters. The other leads to the design of networks which simulate the impedances of a loaded line, approximately a low pass wave-filter, over the greater part of its transmitting band.

It need hardly be mentioned that these terminal transducers may be used to terminate a lattice or other type of wave-filter which has a standard image impedance or, vice versa, that of a derived wave-filter such as the MM' -type. In this manner the terminal image impedance can be altered efficiently from one characteristic to another. The lattice type (z_1, z_2) is itself a symmetrical structure.

The procedure for the design of a wave-filter network to meet specific requirements may even begin with the choice of terminal wave-filter impedance characteristics, which are physical and not in general the same at both ends. The terminal, or reflection, losses due to resistance or other known terminating impedances would thus be definitely known. With these taken into account the internal part would be designed using any type or types so as to fit in between the chosen image impedances without impedance irregularity, as in a composite structure, and give the remainder of the desired transmission characteristic.

PART 1. DERIVATION OF WAVE-FILTERS WHICH POSSESS DESIRABLE IMAGE IMPEDANCES

1.1 General Ladder Type Structure

Of the three simple general types of recurrent or iterative structures, the ladder, lattice and bridged- T types, only the ladder type which has alternate series and shunt impedances, z_1 and z_2 , respectively, has two different image impedances per periodic interval and these are W_1 and W_2 at the two mid-points, mid-series and mid-shunt. The ladder type can therefore be separated on the image basis into either of two kinds of symmetrical sections with two pairs of terminals, mid-series or mid-shunt sections, or into one kind of dissymmetrical section, a mid-half section. The existence of two different image impedances for a section, the general property of all mid-half sections, is a necessary condition for the proper combination of mid-half sections of different related structures to give the desirable terminal impedance results obtained in this paper. Definitions of these three kinds of sections which have been considered in previous papers will be reviewed here.

A mid-series section is that part between the mid-point of one series impedance z_1 and the mid-point of the next series impedance. It has the three impedance branches $\frac{1}{2}z_1$, z_2 , and $\frac{1}{2}z_1$ and has the structure of a T -network. Its image impedance at each end is the mid-series image impedance W_1 .

A mid-shunt section is that part between the mid-point of one shunt admittance $1/z_2$ and the mid-point of the next shunt admittance. It

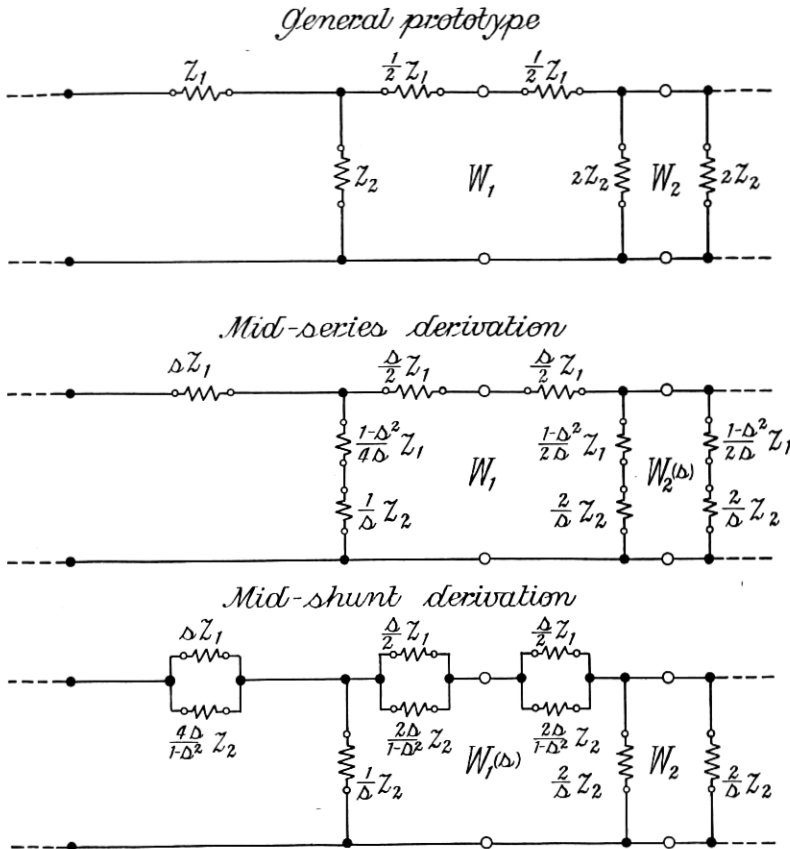

Fig. 1—Fundamental derivations.
 $0 < s \leq 1$.

has the three impedance branches $2z_2$, z_1 , and $2z_2$ and has the structure of a π -network. Its image impedance at each end is the mid-shunt image impedance W_2 . Both of the above symmetrical sections have the same transfer constants, T , as we should expect since both sections represent one full interval of the ladder type structure.

A mid-half section is that dissymmetrical part between the mid-point of one series impedance and the mid-point of the next shunt admittance, or vice versa. The image impedances at the two ends are, respectively, W_1 and W_2 , or vice versa. Its transfer constant is one-half that of a full section, mid-series or mid-shunt. Obviously, two mid-half sections when connected with like image impedances, W_2 or W_1 , adjacent, will form a mid-series or mid-shunt section, respectively.

Well-known formulas for the transfer constant, T , of a full section and for the mid-series and mid-shunt image impedances, W_1 and W_2 , are

$$\cosh T = \cosh (A + iB) = 1 + \frac{z_1}{2z_2} = 1 + 2(U + iV),$$

$$W_1 = \sqrt{z_1 z_2 + \frac{1}{4} z_1^2} = \sqrt{z_1 z_2} \sqrt{1 + U + iV},$$

and

$$W_2 = \frac{z_1 z_2}{\sqrt{z_1 z_2 + \frac{1}{4} z_1^2}} = \frac{\sqrt{z_1 z_2}}{\sqrt{1 + U + iV}} = \frac{z_1 z_2}{W_1}, \quad (1)$$

where

$$U + iV = \frac{z_1}{4z_2}.$$

Such a general structure is illustrated in the upper part of Fig. 1.

1.2 Fundamental Derivations

1.21 Mid-Series Derivation by Operation $D_1(s)$

From any ladder type network z_1, z_2 it is possible to derive a more general one $z_1'(s), z_2'(s)$ which has the same mid-series image impedance W_1 as the prototype, but a transfer constant $T(s)$ and a mid-shunt image impedance $W_2(s)$ which are functions of an arbitrary parameter s . This operation, denoted as $D_1(s)$, is specified by the mathematical and physical relations between the series and shunt impedances of the derived network and those of the prototype, namely,⁶

$$z_1'(s) = s z_1, \quad (2)$$

and

$$z_2'(s) = \frac{1 - s^2}{4s} z_1 + \frac{1}{s} z_2,$$

where $0 < s \leq 1$ for a physical structure. At the limit $s = 1$, it reduces to the prototype. (The superscript "prime" refers to the case of mid-series equivalence.)

⁶ See footnote 3. Also U. S. Patent No. 1,538,964 to O. J. Zobel, dated May 26, 1925.

These relations give for the derived structure in terms of its prototype and parameter s

$$\cosh T(s) = 1 + 2(U(s) + iV(s)),$$

$$W_1 = W_1,$$

and

$$W_2(s) = W_2[1 + (1 - s^2)(U + iV)], \quad (3)$$

where

$$U(s) + iV(s) = \frac{s^2(U + iV)}{1 + (1 - s^2)(U + iV)}.$$

By the above operation a new image impedance $W_2(s)$ has been obtained which is more general than the mid-shunt image impedance of the prototype.

1.22 Mid-Shunt Derivation by Operation $D_2(s)$

From any ladder type network z_1, z_2 it is possible to derive a more general one $z_1''(s), z_2''(s)$ which has the same mid-shunt image impedance W_2 as the prototype, but a transfer constant $T(s)$ and a mid-series image impedance $W_1(s)$ which are functions of an arbitrary parameter s . This operation, denoted as $D_2(s)$, is specified by these mathematical and physical relations between the derived network and its prototype

$$z_1''(s) = \frac{1}{\frac{1}{sz_1} + \frac{1}{\frac{4s}{1 - s^2}z_2}}, \quad (4)$$

and

$$z_2''(s) = \frac{1}{s}z_2,$$

where $0 < s \leq 1$ for a physical structure. At the limit $s = 1$, it reduces to the prototype. (The superscript "second" refers to the case of mid-shunt equivalence.)

From these relations it follows that the derived structure has

$$\cosh T(s) = 1 + 2(U(s) + iV(s)),$$

$$W_1(s) = \frac{W_1}{1 + (1 - s^2)(U + iV)},$$

and

$$W_2 = W_2, \quad (5)$$

where

$$U(s) + iV(s) = \frac{s^2(U + iV)}{1 + (1 - s^2)(U + iV)}.$$

This operation gives a new image impedance $W_1(s)$ which is more general than the corresponding one of the prototype.

The derived structures represented by formulas (2) and (4) as well as their common prototype are given in Fig. 1. A comparison of formulas (1) to (5) shows that for the same value of the parameter s both derived networks have the same transfer constant $T(s)$ and that

$$z_1'(s)z_2''(s) = z_1''(s)z_2'(s) = W_1W_2 = W_1(s)W_2(s) = z_1z_2.$$

Thus the series and shunt impedances of one derived structure are inverse networks of impedance product z_1z_2 of the shunt and series impedances, respectively, of the other one derived from the same prototype, z_1, z_2 . Similarly, the pair of image impedances W_1 and W_2 and the pair $W_1(s)$ and $W_2(s)$ are inverse impedances of this same product. In fact, either infinite structure might have been obtained from the other as such an inverse network; the transfer constants of the two would then necessarily be identical for the ratio of series to shunt impedance would be the same in both.

1.3 "Constant k " Wave-Filter, The Initial Prototype

The "constant k " wave-filter of any class, that is, having any preassigned transmitting and attenuating bands, is a reactance network of ladder type whose product of series and shunt impedances, and therefore iterative impedance k of the corresponding uniform line, is a constant independent of frequency. Putting k equal to the resistance R of the line or impedance with which the wave-filter is normally to be associated, we have

$$z_{1k}z_{2k} = k^2 = R^2 = \text{a constant.}$$

Here and in what follows the additional subscript k implies a relation to the "constant k " wave-filter.

When there is dissipation in the reactance elements, the above relation is strictly satisfied by requiring that the coil dissipation constant, d , and the condenser dissipation constant, d' , be equal for each pair of inverse network elements. For example, when $d = d'$

$$\frac{(d + i)2\pi fL_{1k}}{(d' + i)2\pi fC_{2k}} = \frac{L_{1k}}{C_{2k}} = R^2.$$

There are several reasons for choosing the "constant k " wave-filter as the initial prototype.

1. Its structure and method of design for any class is definitely known.⁷

⁷ See footnote 1. Also U. S. Patent No. 1,509,184 to O. J. Zobel, dated September 23, 1924.

2. It has both standard image impedances, each of which passes through the same cycle of values in all transmitting bands.
3. Each M -type or wave-filter of higher order derived from it can have an improved impedance characteristic which is the same in all transmitting bands.
4. The assumption that its impedances z_{1k} and z_{2k} are general in the analysis makes the results independent of any particular class of wave-filter and hence applicable to all classes.
5. This method of analysis sorts out certain valuable properties which are common to all classes by treating known groups of meshes, z_{1k} and z_{2k} , as units, thereby eliminating the necessity of considering each individual mesh which may be present in the interior of z_{1k} and z_{2k} of any particular class.

It will be appreciated by the reader that the difficulties of the problem for one of the higher classes of wave-filters are thus greatly reduced over what they would be if each mesh had to be taken into account, as might be required by other methods.

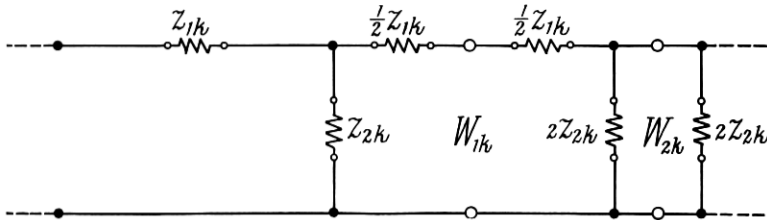

Fig. 2—"Constant k " wave-filter, the initial prototype;
 $z_{1k}z_{2k} = k^2 = R^2 = \text{a constant, independent of frequency.}$

The "constant k " wave-filter of any class, shown in Fig. 2, will be assumed known and is the starting point for obtaining the other structures which are to follow. It has the formulas

$$\cosh T_k = \cosh (A_k + iB_k) = 1 + 2(U_k + iV_k),$$

$$W_{1k} = R\sqrt{1 + U_k + iV_k} = R_{1k} + iX_{1k},$$

and

$$W_{2k} = \frac{R}{\sqrt{1 + U_k + iV_k}} = \frac{R^2}{W_{1k}} = R_{2k} + iX_{2k};$$

where

$$T_k = \text{transfer constant of a full section,} \tag{6}$$

$$\frac{1}{2}T_k = \text{transfer constant of a mid-half section,}$$

$$W_{1k} = \text{image impedance at a series mid-point,}$$

$$W_{2k} = \text{image impedance at a shunt mid-point,}$$

$$U_k + iV_k = \frac{z_{1k}}{4z_{2k}} = \left(\frac{z_{1k}}{2R}\right)^2,$$

and

$$R^2 = z_{1k}z_{2k} = k^2 = \text{a constant.}$$

It will be noted from these formulas that the transfer constant and both image impedances of any "constant k " wave-filter are functions of frequency only through the variables $U_k + iV_k$, or the equivalent $(z_{1k}/2R)^2$ which is a function of z_{1k} . (It would also have been possible to use z_{2k} instead of z_{1k} .) When no dissipation in the elements is assumed, $z_{1k} = r_{1k} + ix_{1k}$ becomes $z_{1k} = ix_{1k}$, a pure reactance, since then $r_{1k} = 0$; also $V_k = 0$. Under these ideal conditions we know that x_{1k} always has a positive slope with frequency,⁸ and when the x_{1k} of a multiple band wave-filter is plotted against frequency it is made up of *negative branches* from $x_{1k} = -\infty$ to 0 and *positive branches* from $x_{1k} = 0$ to $+\infty$ which lie alternately in succession along the frequency scale. These branches are defined to correspond with the sign of x_{1k} . The value of U_k is always negative and ranges continuously with frequency between the values $U_k = 0$ and $-\infty$, once for each branch of x_{1k} . We know also that in a negative branch there is a transmitting band at frequencies corresponding to values from $x_{1k} = -2R$ to 0, and thus from $U_k = -1$ to 0. In a positive branch there is a transmitting band from $x_{1k} = 0$ to $+2R$, thus from $U_k = 0$ to -1 . A low pass band is associated with a positive branch which begins at zero frequency while a high pass band is associated with a negative branch ending at infinite frequency. An internal transmitting band, on the other hand, has this association with a pair of branches, a negative followed on the frequency scale by a positive branch, and in reality consists of two bands which are confluent at $x_{1k} = 0$, i.e., $U_k = 0$, where the two branches join. Such a confluent band is formed by the junction of two bands which occur separately in a wave-filter of higher class than this "constant k " wave-filter but with the same configuration of elements.

Since all negative branches are similar, as well as all positive branches, an approximate representation of the frequency characteristics of any "constant k " wave-filter can be constructed from the characteristics which belong to each of these two kinds of branches. It is necessary to consider both a negative branch and a positive branch since the characteristics of one branch differ in their variations with frequency from those of the other. Differences would naturally be expected from the fact that in formulas (6) which hold for both branches the variable U_k varies with increasing frequency from $U_k = -\infty$ to 0 in a negative branch and from $U_k = 0$ to $-\infty$ in a

⁸ See page 5 of paper in footnote 1.

positive branch. When $V_k = 0$, as when no dissipation is assumed, the formulas become functions of U_k only but contain a certain indeterminateness regarding the signs attributable to the phase constants and image impedance reactances of the two branches. This difficulty vanishes when dissipation is present to give V_k a value different from zero, as in a physical wave-filter.

With dissipation such as to preserve the "constant k " relation it is readily shown that V_k is negative in a negative branch and positive in a positive one; that is, V_k has the sign of x_{1k} . This follows directly from the formula

$$U_k + iV_k = \left(\frac{z_{1k}}{2R} \right)^2 = \frac{(r_{1k}^2 - x_{1k}^2)}{4R^2} + i \frac{r_{1k}x_{1k}}{2R^2},$$

since r_{1k} must be a positive resistance in a passive network. On the basis of this result it follows from formulas (6) that⁹ in a negative branch

$$\begin{aligned} x_{1k}, V_k, B_k \text{ and } X_{1k} \text{ are negative;} \\ x_{2k} \text{ and } X_{2k} \text{ are positive.} \end{aligned}$$

In a positive branch these signs are reversed.

The characteristics of two such representative branches are shown in Fig. 3, joined as they would be to form an internal transmitting band. The scale of abscissas is U_k rather than frequency in order to be general, and U_k varies in going from left to right from $-\infty$ to 0 for the negative branch and from 0 to $-\infty$ for the positive branch. In this way a movement along the abscissa-axis from left to right always corresponds to an increase in frequency. A translation from the U_k to the frequency-scale can be obtained in any particular case through the known relationship between U_k and frequency. Such a translation would be equivalent to a variable expansion or contraction of the above characteristics parallel to the abscissa-axis. The effects of dissipation on the different characteristics are indicated by broken lines and show a rounding-off of abrupt changes. Here, for convenience, it was assumed that $V_k = .01U_k$ in a negative branch and $V_k = -.01U_k$ in a positive branch. If each pair of characteristics is considered as separated by an imaginary line perpendicular to the U_k -axis at $U_k = 0$, then a comparison will yield the statement that corresponding pairs of A_k , R_{1k} and R_{2k} are images of each other with respect to such lines, while pairs of B_k , X_{1k} and X_{2k} are images but also opposite in sign.

⁹ See also page 577 of paper in footnote 2.

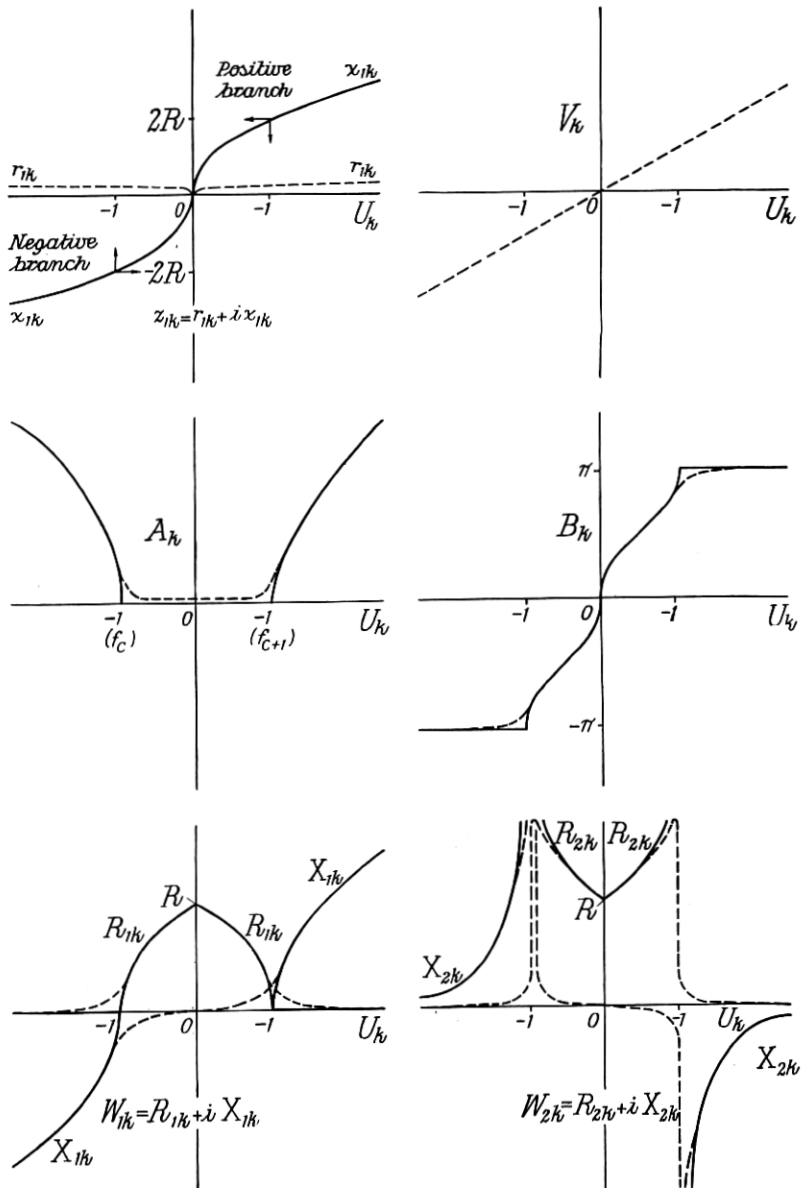

Fig. 3—Characteristics of "constant k " wave-filters.
(Broken lines indicate the effects of dissipation.)

1.4 Sequence 1

As already stated in the Introduction to this paper, the successive wave-filter structures of any class which comprise Sequence 1 are derived from the known "constant k " wave-filter taken as the initial prototype by performing in succession the operations $D_1(m)$, then $D_2(m')$, $D_1(m'')$, etc. They may be considered as wave-filters of higher and higher order since they contain a greater and greater number of arbitrary parameters. The parameters of the alternate operations $D_1(s)$ and $D_2(s)$ are in the order of $s = m, m', m'', \text{etc.}$

The small letter m with superscripts is used as the notation for all the parameters in order to denote their association with "mid" of mid-point impedances, since mid-points are under consideration here in ladder type networks. Where the initial prototype is the "constant k " wave-filter, as it is here, I have used a terminology for the derived structures whose basis is the capital letter M with superscripts to correspond with those of the associated small letter parameters. Thus, I have shortened the expression "mid-series derived, parameter m ladder type" to "series M -type"; similarly for the other structures.

"Constant k " Series M -type Shunt MM' -type Series $MM'M''$ -type

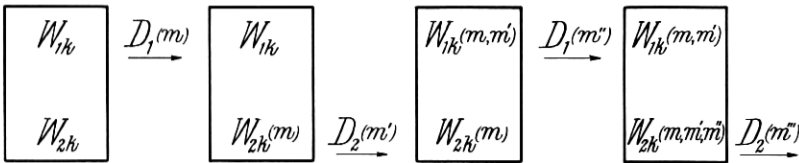

Fig. 4—Sequence 1.

The wave-filters of Sequence 1, so designated, can be expressed concisely in the following symbolic manner where any part within brackets represents a ladder type structure. Each operation is to be performed upon the structure within brackets to its right; therefore, to obtain the actual series and shunt impedances which result in any particular case when two or more operations are involved, these operations would begin at the right with $D_1(m)$ on $[k]$, the "constant k " wave-filter.

$$\begin{aligned}
 \text{"Constant } k\text{"} &= [k], \\
 \text{Series } M\text{-type} &= D_1(m)[k], \\
 \text{Shunt } MM'\text{-type} &= D_2(m')[D_1(m)[k]], \\
 \text{Series } MM'M''\text{-type} &= D_1(m'')[D_2(m')[D_1(m)[k]]], \text{ etc.}
 \end{aligned} \tag{7}$$

A diagram which illustrates this process and gives as well the notation of the resulting image impedances in the successive structures

of Sequence 1 is shown in Fig. 4. Each rectangle represents a wave-filter of ladder type having the two mid-point image impedances as indicated. The operation symbol between each succeeding pair of rectangles shows what operation has been performed and the arrow points towards the derived structure of higher order, being placed in line with the image impedances which are identical for the pair. Thus it is seen that each derived structure has one identical and one more general image impedance than the preceding structure. In the sequence the new image impedances appear alternately at mid-series and mid-shunt points, beginning with the latter here.

The series and shunt impedances of the different structures which become more and more complicated with increase in parameters are derived by performing the above operations but their detailed consideration will be deferred to a later point.

The transfer constants of the various members of this sequence are found by carrying out the proper operations based upon formulas (3), (5) and (6) and can be expressed by one formula, namely

$$\cosh T_k(g) = 1 + \frac{2g^2(U_k + iV_k)}{1 + (1 - g^2)(U_k + iV_k)}, \quad (8)$$

where $g = 1, m, mm', mm'm'',$ etc., in a decreasing sequence.¹⁰ The value of g for the structure of any order is equal to the product of all of its parameters, the first value above, $g = 1$, being that of the "constant k " wave-filter. This is, for example, because by (3)

$$U_k(m, m', m'') + iV_k(m, m', m'') = \frac{m^2 m'^2 m''^2 (U_k + iV_k)}{1 + (1 - m^2 m'^2 m''^2)(U_k + iV_k)}. \quad (9)$$

The image impedances in Sequence 1 which are derived in a corresponding manner have these formulas.

$$\begin{aligned} W_{1k} &= W_{1k}, \\ W_{2k}(m) &= W_{2k} [1 + a(U_k + iV_k)], \\ W_{1k}(m, m') &= \frac{W_{1k} [1 + a(U_k + iV_k)]}{[1 + a'(U_k + iV_k)]}, \\ W_{2k}(m, m', m'') &= \frac{W_{2k} [1 + a(U_k + iV_k)] [1 + a''(U_k + iV_k)]}{[1 + a'(U_k + iV_k)]}, \text{ etc.,} \end{aligned} \quad (10)$$

¹⁰ Computations for the transfer constant can be made accurately from formulas for $\cosh^{-1}(x + iy)$ given in Appendix III of the paper "Distortion Correction in Electrical Circuits with Constant Resistance Recurrent Networks," O. J. Zobel, *B. S. T. J.*, July, 1928.

where

$$\begin{aligned} a &= 1 - m^2, \\ a' &= 1 - m^2m'^2, \\ a'' &= 1 - m^2m'^2m''^2, \text{ etc.,} \end{aligned}$$

in an increasing sequence approaching unity. W_{1k} and W_{2k} are the "constant k " image impedances of formulas (6). The continuation of this series of image impedances is quite obvious, a new factor appearing alternately in the numerator and in the denominator.

Each factor in the numerator gives the image impedance a resonant point in an attenuating band where the image impedance is a reactance and $U_k < -1$; that is, at $U_k = -1/a$, or $-1/a''$, etc., neglecting dissipation with $V_k = 0$. A factor in the denominator gives an anti-resonant point; at $U_k = -1/a'$, etc. Since a' lies between a and a'' , etc., these resonant and anti-resonant points alternate as in a general reactance network. Only the resonant or anti-resonant point due to the new factor added coincides with the point of infinite attenuation in the corresponding new structure, as may be seen upon comparing formulas (8) and (10), neglecting dissipation. These properties outside a transmitting band may or may not be desirable in certain kinds of circuits. They are of importance when considering terminal losses in an attenuating band, as in Section 2.6.

1.5 Sequence 2

Here the derived structures are obtained by performing in succession the operations $D_2(m)$, then $D_1(m')$, $D_2(m'')$, etc., where the initial

"Constant k " Shunt M -type Series MM' -type Shunt MM'' -type

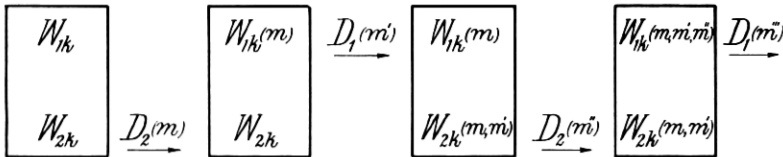

Fig. 5—Sequence 2.

prototype is the "constant k " wave-filter. Using the same notation and terminology as before, the wave-filters of Sequence 2 when expressed symbolically are

$$\begin{aligned} \text{"Constant } k\text{"} &= [k], \\ \text{Shunt } M\text{-type} &= D_2(m)[k], \\ \text{Series } MM'\text{-type} &= D_1(m')[D_2(m)[k]], \\ \text{Shunt } MM'M''\text{-type} &= D_2(m'')[D_1(m')[D_2(m)[k]]], \text{ etc.} \end{aligned} \tag{11}$$

A corresponding diagram which illustrates this process is that of Fig. 5.

The transfer constants of these wave-filters are also given by formula (8) which includes (9).

The image impedances in Sequence 2 are

$$\begin{aligned} W_{2k} &= W_{2k}, \\ W_{1k}(m) &= \frac{W_{1k}}{[1 + a(U_k + iV_k)]}, \\ W_{2k}(m, m') &= \frac{W_{2k}[1 + a'(U_k + iV_k)]}{[1 + a(U_k + iV_k)]}, \\ W_{1k}(m, m', m'') &= \frac{W_{1k}[1 + a'(U_k + iV_k)]}{[1 + a(U_k + iV_k)][1 + a''(U_k + iV_k)]}, \text{ etc.,} \end{aligned} \quad (12)$$

where $a, a', a'',$ etc., have the same values as in (10).

1.6 Relations Between Sequence 1 and Sequence 2

Carrying through operations for the determination of the structures of the series and shunt impedances in these wave-filters, the following results are found:

a. Each pair of structures of the same order in the two sequences is a pair of inverse networks of impedance product R^2 .

That is, if the series M -type has the series and shunt impedances $z_{1k}'(m)$ and $z_{2k}'(m)$, and the shunt M -type $z_{1k}''(m)$ and $z_{2k}''(m)$, the inverse network relations are

$$z_{1k}'(m)z_{2k}''(m) = z_{1k}''(m)z_{2k}'(m) = R^2.$$

For the MM' -types, using similar notation,

$$z_{1k}'(m, m')z_{2k}''(m, m') = z_{1k}''(m, m')z_{2k}'(m, m') = R^2,$$

and so on for the higher order pairs. Consequently, one structure of each pair might be obtained from the other as such an inverse network.¹¹

b. The transfer constants of both structures of a pair are the same.

This result would come from the inverse network relations which give both structures the same ratio of series to shunt impedances, a ratio which determines the transfer constant. It has already been found in formula (8) where the value of g is the same for both structures, of any order.

¹¹ The structures indicated or to be shown in detail in Sequence 1 and Sequence 2 can be generalized as ladder type derivations from any initial prototype z_1, z_2 . This is done by a simple replacement of z_{1k} and z_{2k} by z_1 and z_2 , respectively; of R^2 by the product z_1z_2 ; and by the omission of the subscripts, k , throughout.

c. The series and shunt image impedances of a pair are inverse networks of impedance product R^2 .

Such results would also follow from (a) above together with the consideration of mid-point terminations. They are verified by comparison of formulas (10) and (12) which give

$$W_{1k}W_{2k} = W_{1k}(m)W_{2k}(m) = W_{1k}(m, m')W_{2k}(m, m') \\ = W_{1k}(m, m', m'')W_{2k}(m, m', m'') = \dots = R^2.$$

d. Both image impedances of either MM' -type, or of either one of a higher order pair, may be adjusted dependently without changing its transfer constant; the ratio of the two image impedances is fixed when the transfer constant is fixed.

This can be seen from the fact that the transfer constant depends upon the parameters only in their product, g , and from the formulas for two consecutive impedances in (10) or (12).

1.7 M -Type Wave-Filters

These are the wave-filters of the first order in each sequence and contain one arbitrary parameter, m . Although they are quite well-known, it is necessary to include them here for the sake of continuity and because of the fact that they are to be used later.

The series M -type has the formulas

$$z_{1k}'(m) = mz_{1k}, \\ z_{2k}'(m) = \frac{1 - m^2}{4m} z_{1k} + \frac{1}{m} z_{2k}, \\ \cosh T_k(m) = 1 + \frac{2m^2(U_k + iV_k)}{1 + (1 - m^2)(U_k + iV_k)}, \quad (13)$$

and

$$W_{1k} = R\sqrt{1 + U_k + iV_k}, \\ W_{2k}(m) = \frac{R[1 + (1 - m^2)(U_k + iV_k)]}{\sqrt{1 + U_k + iV_k}}.$$

In the shunt M -type

$$z_{1k}''(m) = \frac{1}{\frac{1}{mz_{1k}} + \frac{1}{\frac{4m}{1 - m^2} z_{2k}}}, \\ z_{2k}''(m) = \frac{1}{m} z_{2k}, \quad (14) \\ \cosh T_k(m) = \text{same as in (13)}, \\ W_{1k}(m) = \frac{R\sqrt{1 + U_k + iV_k}}{[1 + (1 - m^2)(U_k + iV_k)]},$$

and

$$W_{2k} = \frac{R}{\sqrt{1 + U_k + iV_k}}$$

In the above $0 < m \leq 1$. At the limit $m = 1$, the two structures reduce to the "constant k " wave-filter; also $W_{1k}(m = 1) = W_{1k}$ and $W_{2k}(m = 1) = W_{2k}$.

A mid-half section of each of these wave-filters is shown in Fig. 6. It is to be remembered that the transfer constant of a mid-half section is one-half that of the full section given in the formulas.

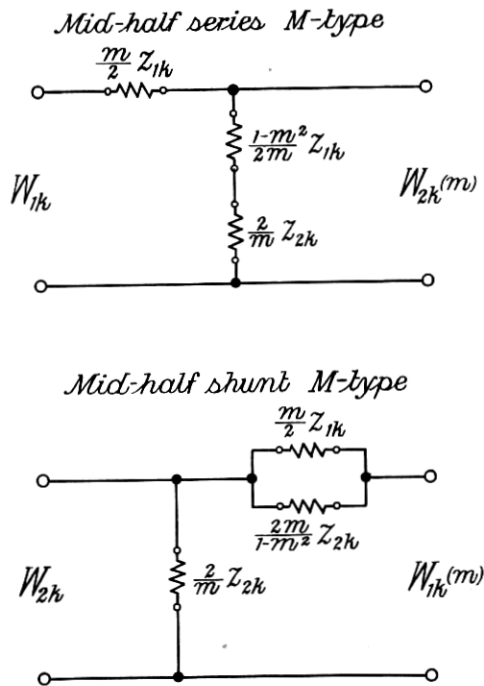

Fig. 6—Mid-half sections of M -type wave-filters.

To illustrate the propagation and impedance characteristics of M -types, as in Fig. 7, the parameter was taken to have the value $m = .6$. The attenuation constant has one maximum just beyond each critical frequency, where $U_k = -1/(1 - m^2) = -1.5625$, and in this particular case the image impedances shown have the fairly constant resistance values over a large part of each transmitting band to which reference has been made. With other values of m there may

or may not be in the range from $U_k = 0$ to -1 one maximum for $W_{1k}(m)$ and one minimum for $W_{2k}(m)$. The image impedances at the other mid-points are independent of m and are identical with those of the "constant k " wave-filter already shown in Fig. 3.

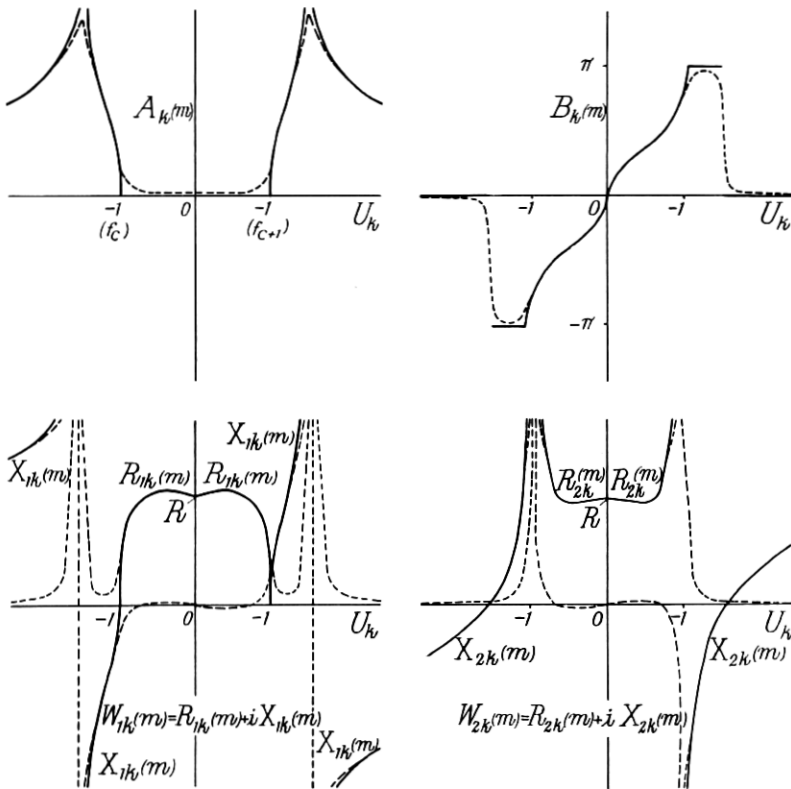

Fig. 7—Characteristics of M -type wave-filters;

$$m = .6.$$

(W_{1k} and W_{2k} are illustrated in Fig. 3. Broken lines indicate the effects of dissipation.)

1.8 MM' -Type Wave-Filters

As wave-filters of the second order in each sequence they have two parameters, m and m' . Their series and shunt impedances are derived by means of the single operations with parameter m' performed in the regular manner upon the M -type structures as prototypes which have the formulas (13) and (14).

Formulas for the series MM' -type are

$$z_{1k}'(m, m') = \frac{1}{\frac{1}{mm'z_{1k}} + \frac{1}{\frac{4mm'}{1-m^2}z_{2k}}},$$

$$z_{2k}'(m, m') = \frac{1}{\frac{1}{\frac{m(1-m^2)}{4m'}z_{1k}} + \frac{1}{\frac{m(1-m^2)}{m'(1-m^2)}z_{2k}}} + \frac{1}{mm'}z_{2k}, \quad (15)$$

$$\cosh T_k(m, m') = 1 + \frac{2m^2m'^2(U_k + iV_k)}{1 + (1 - m^2m'^2)(U_k + iV_k)},$$

$$W_{1k}(m) = \frac{R\sqrt{1 + U_k + iV_k}}{[1 + (1 - m^2)(U_k + iV_k)]},$$

and

$$W_{2k}(m, m') = \frac{R[1 + (1 - m^2m'^2)(U_k + iV_k)]}{[1 + (1 - m^2)(U_k + iV_k)]\sqrt{1 + U_k + iV_k}},$$

where $0 < m \leq 1$, and $0 < m' \leq 1$.

As a limiting value, $W_{2k}(m, m' = 1) = W_{2k}$.

For the shunt MM' -type

$$z_{1k}''(m, m') = \frac{1}{\frac{1}{mm'z_{1k}} + \frac{1}{\frac{m'(1-m^2)}{m(1-m'^2)}z_{1k} + \frac{4m'}{m(1-m'^2)}z_{2k}}}, \quad (16)$$

$$z_{2k}''(m, m') = \frac{1-m^2}{4mm'}z_{1k} + \frac{1}{mm'}z_{2k},$$

$\cosh T_k(m, m')$ = same formula as in (15),

$$W_{1k}(m, m') = \frac{R[1 + (1 - m^2)(U_k + iV_k)]\sqrt{1 + U_k + iV_k}}{[1 + (1 - m^2m'^2)(U_k + iV_k)]},$$

and

$$W_{2k}(m) = \frac{R[1 + (1 - m^2)(U_k + iV_k)]}{\sqrt{1 + U_k + iV_k}},$$

where as before $0 < m \leq 1$, and $0 < m' \leq 1$. A limiting value here is $W_{1k}(m, m' = 1) = W_{1k}$.

The MM' -type wave-filters have structural designs which can be inferred from their respective mid-half sections of Fig. 8; they may have characteristics such as illustrated in Fig. 9 where the parame-

ters are $m = .7230$ and $m' = .4134$; the reason for this particular set of values will be explained later. The transfer constant is the same as that of an M -type of parameter equal to the product $mm' = .2989$. With other values of m and m' the image impedances $W_{1k}(m, m')$ and $W_{2k}(m, m')$, which in the transmitting bands are pure resistances if dissipation is neglected, can be given a variety of characteristics as is apparent from their formulas. In fact their physical possibilities can

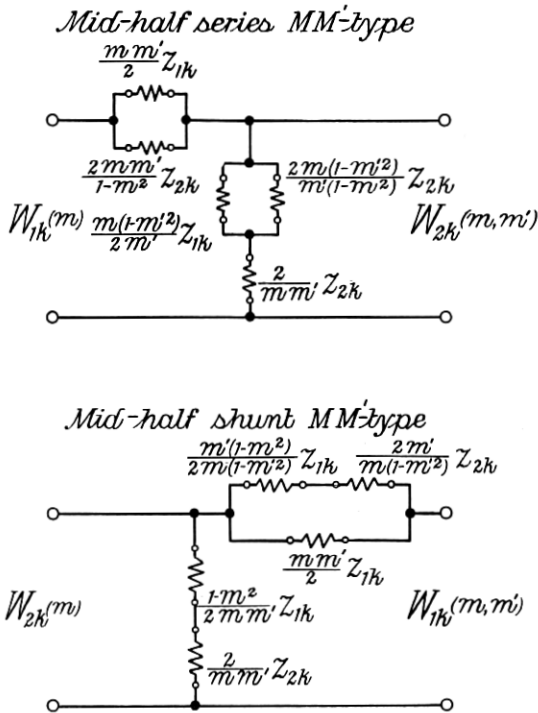

Fig. 8—Mid-half sections of MM' -type wave-filters.

then be described by the following statement. In the range from $U_k = 0$ to -1 the characteristic corresponding to the positive ratio $y = W_{1k}(m, m')/R = R/W_{2k}(m, m')$ may have no maximum or minimum, one maximum, or one maximum and one minimum; at $U_k = 0$, $y = 1$ and at $U_k = -1$, $y = 0$. All of these structures which have the same value of the product $g = mm'$, have the same transfer constant. Thus, it is possible to keep the transfer constant fixed and vary the image impedances.

No structures of any higher order will be worked out here in detail since for all practical purposes the MM' -types just considered will be

found capable of meeting the ideal impedance requirements. If desired, the structures for the $MM'M''$ -types and higher orders can easily be derived by the regular operations indicated. In them some slight reductions in the number of elements can be made because there are then three or more similar impedances in one branch.

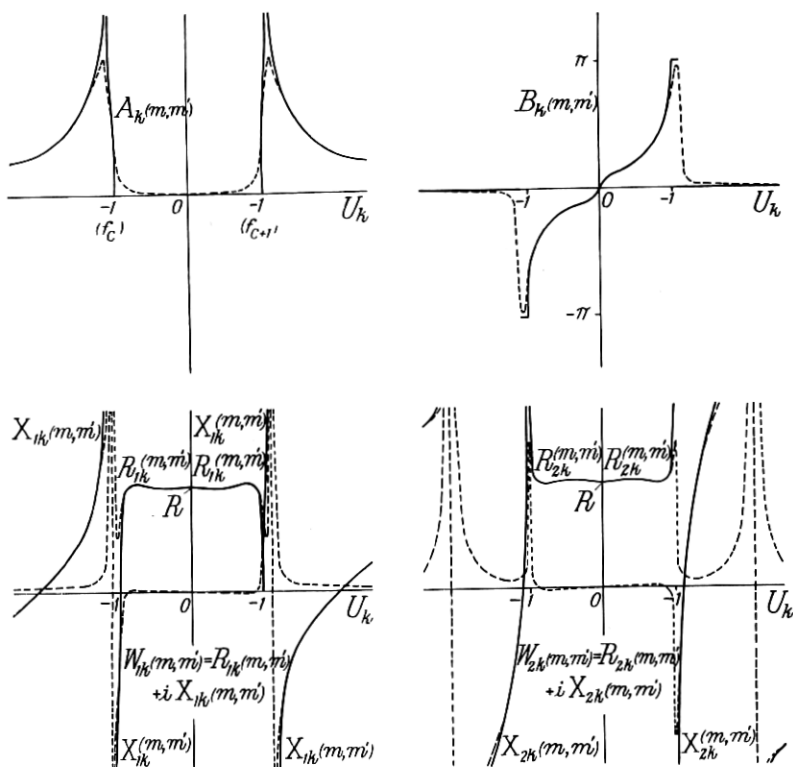

Fig. 9—Characteristics of MM' -type wave-filters;

$$m = .7230, \quad m' = .4134.$$

($W_{1k}(m)$ and $W_{2k}(m)$ are illustrated in Fig. 7. Broken lines indicate the effects of dissipation.)

It should be quite obvious that a wave-filter of any order reduces to the "constant k " wave-filter when every one of its parameters reaches its limiting value, unity.

1.9 Frequency Relation in the Attenuation Characteristic of an M -Type or Higher Order Wave-Filter of Any Class

The attenuation characteristics of M -type and MM' -type wave-filters which have been illustrated in a limited frequency range show

that when dissipation is neglected there is infinite attenuation at some frequency within each branch of x_{1k} . Formula (8), when $V_k = 0$, gives in the attenuating bands where $U_k \leq -1$

$$\cosh A_k(g) = \left| 1 + \frac{2g^2 U_k}{1 + (1 - g^2) U_k} \right|, \quad (17)$$

in which $g = m, mm', mm'm'',$ etc., for the M -types and higher orders. The critical frequencies occur where the attenuation constant becomes zero, i.e., at $U_k = -1$, while the frequencies of infinite attenuation occur where it becomes infinite at $U_k = -1/(1 - g^2)$. Since, when $V_k = 0$, $(z_{1k}/2R)^2 = U_k$, we have the following results:

At critical frequencies $f_0, f_1,$ etc.,

$$z_{1k} = \pm i2R. \quad (18)$$

At frequencies of infinite attenuation, $f_{0\infty}, f_{1\infty},$ etc.,

$$z_{1k} = \pm \frac{i2R}{\sqrt{1 - g^2}}, \quad (19)$$

the number of such frequencies being equal to the number of critical frequencies.

A very simple relation has been found between these two sets of frequencies in the case of any multiple band pass M -type or higher order wave-filter. Such a relation is given here for each of the four general groups into which all classes of band pass wave-filters may be divided, each group having n internal bands with or without low pass and high pass bands.

Group 1.—Low-and- n Band Pass.

$$f_{0\infty} f_{1\infty} \cdots f_{2n\infty} = \frac{1}{\sqrt{1 - g^2}} f_0 f_1 \cdots f_{2n}. \quad (20)$$

Group 2.— n Band-and-High Pass.

$$f_{1\infty} f_{2\infty} \cdots f_{(2n+1)\infty} = \sqrt{1 - g^2} f_1 f_2 \cdots f_{2n+1}. \quad (21)$$

Group 3.—Low- n Band-and-High Pass.

$$f_{0\infty} f_{1\infty} \cdots f_{(2n+1)\infty} = f_0 f_1 \cdots f_{2n+1}. \quad (22)$$

Group 4.— n Band Pass.

$$f_{1\infty} f_{2\infty} \cdots f_{2n\infty} = f_1 f_2 \cdots f_{2n}. \quad (23)$$

For this group there is a further relation but it applies to the

impedance characteristics. It contains those frequencies in the transmitting bands where all image impedances become equal to R and where the series impedances belonging to the different orders become resonant. These resonant frequencies f_{1r} , f_{2r} , etc., are the same as those of z_{1k} ; that is, where $z_{1k} = 0$. The relation is

$$f_{1r}f_{2r} \cdots f_{nr} = \sqrt{f_1f_2 \cdots f_{2n}}. \quad (24)$$

It may be noticed that relations (20) and (21) for Groups 1 and 2 are the only ones which depend upon the parameter g . The proofs of all these relations are to be found in Appendix I together with certain reactance frequency theorems.

PART 2. FORMATION OF TERMINAL WAVE-FILTER TRANSDUCERS

2.1 General Design Method

In the Introduction of this paper the method of forming the two general kinds of transducers under consideration has been quite fully discussed. Hence, only a brief repetition will be made here.

The series terminal transducer is designed for connection to the standard mid-series image impedance, W_{1k} , and is formed by connecting in tandem an arbitrary number of single mid-half sections of successively derived structures in Sequence 1, beginning with the series M -type. The image impedances are identical at each junction and adjacent series or shunt impedances can be merged. The number of arbitrary parameters in the final image impedance function is equal to the number of mid-half sections which have been so united. This impedance characteristic is then fixed to give a desired physical result, whence the parameters of all intervening mid-half sections are likewise fixed. The attenuation peaks of successive sections are nearer and nearer the critical frequencies.

The shunt terminal transducer for connection to the standard mid-shunt image impedance, W_{2k} , is designed in a similar manner from the wave-filters of Sequence 2, beginning with the shunt M -type.

From a theoretical standpoint the more mid-half sections used in this composition to obtain a desired constant terminal impedance, the better the possible approximation. The same method of solving for the parameters can be used in all cases. But, in practice, two sections appear to be sufficient.

2.2 Transducers Having Two Parameters

Proceeding on the above basis the two-parameter structures of Fig. 10 are obtained. Their formation will be obvious from Figs.

6 and 8, taking into account the merging of similar impedances at the junctions.

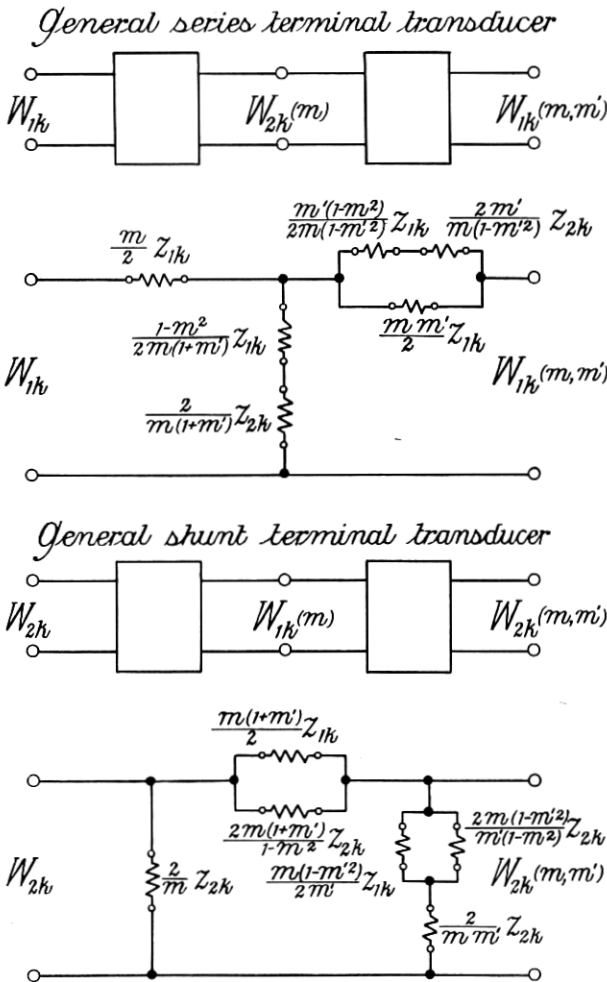

Fig. 10—General terminal transducers.

The transfer constants of both structures are identical being given by

$$T = \frac{1}{2} [T_k(m) + T_k(m, m')]. \tag{25}$$

At their initial terminals the image impedances are respectively the standard ones, W_{1k} and W_{2k} , which have the relations

$$\frac{W_{1k}}{R} = \frac{R}{W_{2k}} = \sqrt{1 + U_k + iV_k}; \tag{26}$$

and at their final terminals the image impedance relations are functions of m and m' , namely,

$$y = \frac{W_{1k}(m, m')}{R} = \frac{R}{W_{2k}(m, m')} = \frac{[1 + a(U_k + iV_k)]\sqrt{1 + U_k + iV_k}}{[1 + a'(U_k + iV_k)]}, \quad (27)$$

where $a = 1 - m^2$, and $a' = 1 - m^2 m'^2$. Since m and m' lie between zero and unity, it follows that $0 \leq a \leq a' < 1$.

When there is no dissipation in the network elements, $V_k = 0$ and all these image impedances are pure resistances in all transmitting bands. Then the image impedance ratio y is there real and it can be given a variety of characteristics depending upon the choice of parameters a and a' . For the range $U_k = 0$ to -1 , y as a function of U_k may have no maximum or minimum, one maximum, or one maximum and one minimum; at $U_k = 0$, $y = 1$ and at $U_k = -1$, $y = 0$.

The parameters corresponding to any such physical characteristic can be determined from the values of y at two non-zero values of U_k , where now

$$y = \frac{[1 + aU_k]\sqrt{1 + U_k}}{[1 + a'U_k]}.$$

This, when rewritten, yields the general linear equation in a and a'

$$-ua + va' = w, \quad (28)$$

where

$$u = -U_k\sqrt{1 + U_k},$$

$$v = -yU_k,$$

and

$$w = y - \sqrt{1 + U_k}.$$

For generality, let the data be

$$y = y_1 \quad \text{at} \quad (U_k)_1,$$

and

$$y = y_2 \quad \text{at} \quad (U_k)_2.$$

Substitution of these values in (28) gives two simultaneous linear equations in a and a' whose solution is

$$a = \frac{v_1w_2 - v_2w_1}{u_1v_2 - u_2v_1}, \quad (29)$$

and

$$a' = \frac{u_1w_2 - u_2w_1}{u_1v_2 - u_2v_1}.$$

Then from (27)

$$m = \sqrt{1 - a},$$

and

$$m' = \sqrt{\frac{1 - a'}{1 - a}}. \quad (30)$$

The maximum and minimum values of y (where $dy/dU_k = 0$) are at the two values of U_k

$$U_k = \frac{-(3a - a') \pm \sqrt{(3a - a')^2 - 4aa'(1 + 2a - 2a')}}{2aa'}. \quad (31)$$

Where it is desired to have an especially constant value, $y = 1$, in the neighborhood of $U_k = 0$, the parameters might be determined from an expansion of the expression for y in powers of U_k . Equating these coefficients of the first and second powers separately to zero would give two independent equations from which to derive the parameters.¹²

2.3 Fixed Designs

The primary interest here is to obtain designs in which the final image impedances are approximately constant resistances equal to R over the entire useful parts of all transmitting bands. Such impedances require a y -characteristic which is close to unity from $U_k = 0$ to the neighborhood of $U_k = -1$. With this objective a few preliminary trials showed that very satisfactory results are obtained with the assumed data

$$\begin{aligned} y_1 = 1 & \quad \text{at} \quad (U_k)_1 = - .65, \\ y_2 = 1 & \quad \text{at} \quad (U_k)_2 = - .90. \end{aligned}$$

Then from (29) and (30) of the previous Section

$$\begin{aligned} a = .4773, & \quad a' = .9107; \\ \text{and} & \\ m = .7230, & \quad m' = .4134. \end{aligned} \quad (32)$$

These values fix the general structures of Fig. 10, giving the specific ones of Fig. 11 which are made up of definite proportions of the impedances z_{1k} and z_{2k} of the "constant k " wave-filter of that class, assumed known. The detailed y -characteristic of Fig. 12 shows that in this case there is less than a 2 per cent departure of y from the constant value unity over the continuous range from $U_k = 0$ to

¹² A problem of terminal impedance is also included in the paper, "Die Siebschaltungen der Fernmeldetechnik," W. Cauer, *Zeitschrift für Angewandte Mathematik und Mechanik*, October, 1930, p. 425-433.

Fixed series terminal transducer

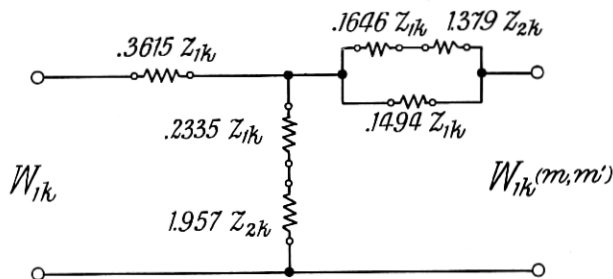

Fixed shunt terminal transducer

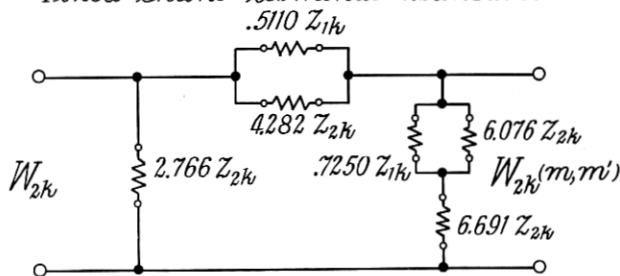
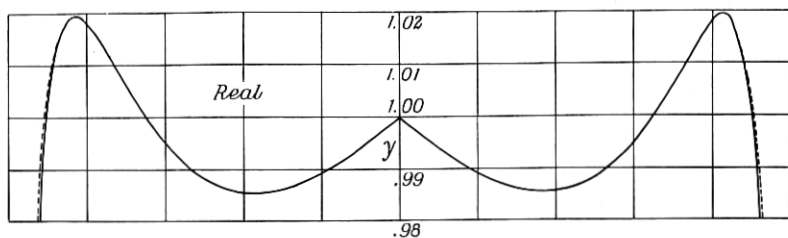

Fig. 11—Fixed terminal transducers;

$$m = .7230, \quad m' = .4134.$$



$$y = \frac{W_{1k}^{(m, m')}}{R} = \frac{R}{W_{2k}^{(m, m')}} \quad (m = .7230, m' = .4134)$$

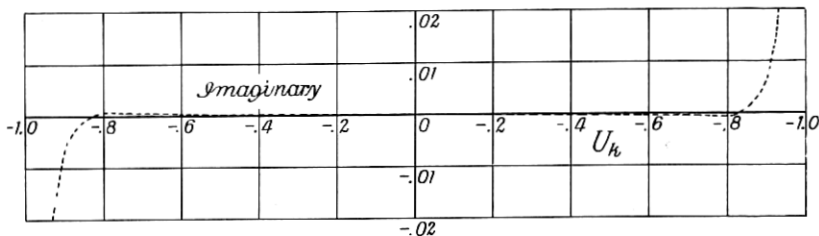

Fig. 12—Detailed terminal image impedance characteristics in the transmitting bands of fixed terminal transducers.

(Broken lines are for dissipation with $V_k = \pm .01 U_k$).

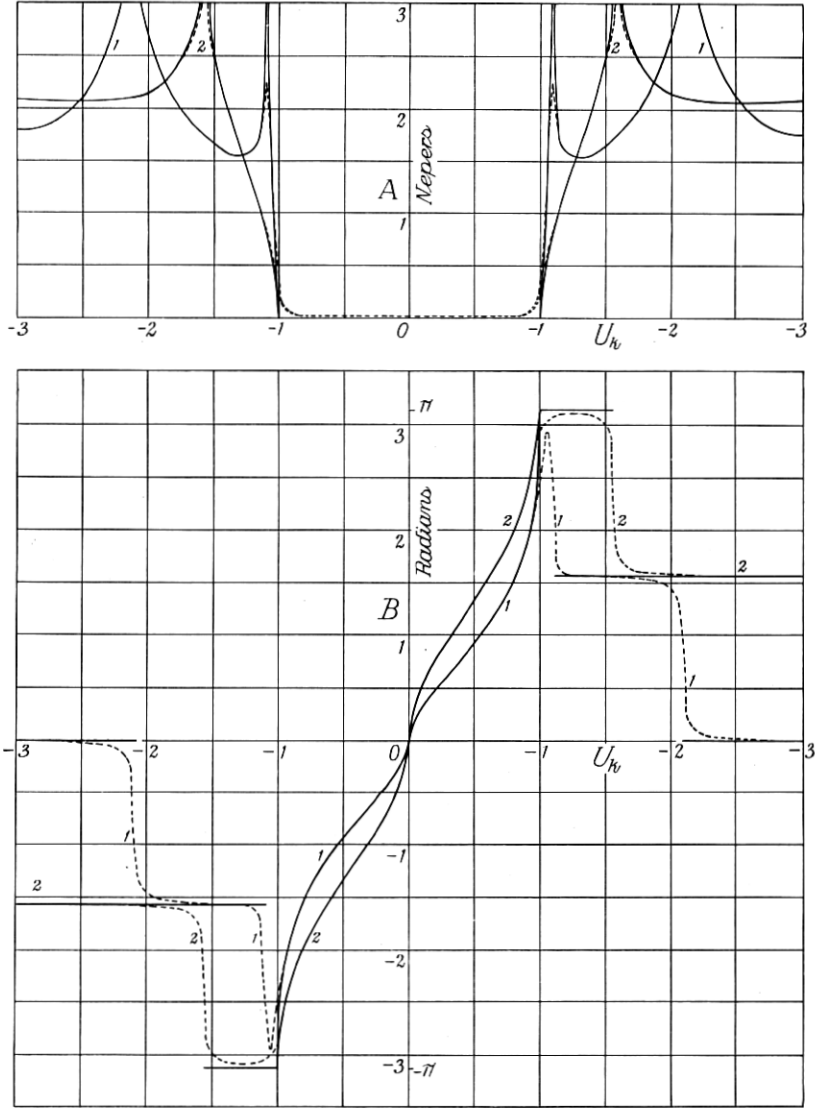

Fig. 13—Transfer constants ($T = A + iB$)—

- (1) of fixed terminal transducers,
- (2) of comparison transducers.

(A comparison transducer consists of one mid-half section of the "constant k " wave-filter and one of either M -type, where $m = .6$. Broken lines are for dissipation with $V_k = \pm .01 U_k$).

$U_k = -.92$ in every branch, which range includes the useful part of a branch. In low pass and band pass wave-filters this total range corresponds to 96 per cent of the theoretical band widths. From (31) there is a minimum $y = .9857$ at $U_k = -.3696$, and a maximum $y = 1.0198$ at $U_k = -.8297$. Of course, other values of the parameters in this neighborhood would also be quite satisfactory. They might even be fixed by choosing the frequencies of infinite attenuation in the two half sections. But the above were taken in order to fix the final networks.

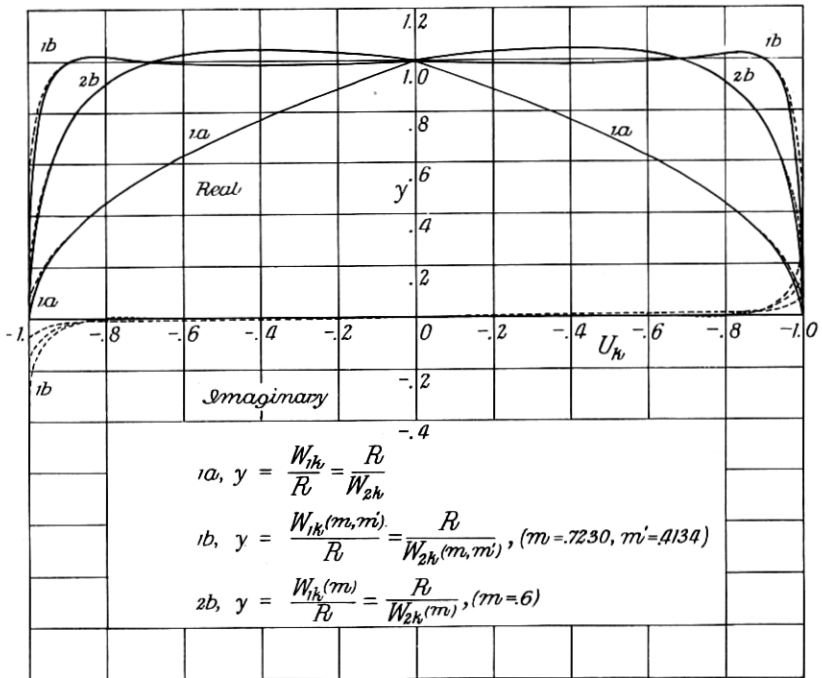

Fig. 14—Image impedance characteristics in the transmitting bands—

(1a, 1b) of fixed terminal transducers,
 (1a, 2b) of comparison transducers.

(Broken lines are for dissipation with $V_k = \pm .01 U_k$).

The transfer constants of these fixed terminal transducers of Fig. 11 are represented by the general attenuation and phase characteristics of Fig. 13. Here also are shown the corresponding characteristics of two comparison transducers, one of which is made up of a mid-half section each of the "constant k " and of the shunt M -type wave-filters and has the image impedances W_{1k} and $W_{1k}(m)$. The other, made up similarly, has the image impedances W_{2k} and $W_{2k}(m)$. In

both comparison transducers $m = .6$, this value of the parameter giving results which are representative of the best constant terminal impedances possible in transducers with terminal M -types. (These comparison networks are identical with the general ones of Fig. 10 in which $m = 1$ and $m' = .6$.) Corresponding image impedance ratios in a transmitting band are given in Fig. 14 where curves $1a$ and $1b$ are characteristics for the two ends of the new terminal transducers of Fig. 11, while curves $1a$ and $2b$ are those of the comparison networks. The superior merits of the new transducers can be seen from Figs. 13 and 14; for in addition to giving improved and practically ideal terminal impedances they have attenuation characteristics just outside the transmitting bands which rise more rapidly than those of the comparison transducers.

By the use of such and other fixed terminal transducers at one or both ends of a wave-filter network, the flexibility of the composite method of designing wave-filters is still retained. The transducer transfer constants and terminal losses due to reflection at given terminating impedances are known in advance. The interior of the composite wave-filter can then be built up of ladder, lattice or other types of sections so that the desired total transmission characteristic is obtained. Constant resistance phase networks can also be added at a resistance termination to help improve the phase characteristic in the transmitting bands, if necessary.

2.4 Designs for Low Pass, High Pass, Low-and-High Pass and Band Pass Wave-Filters

These fixed transducers of Fig. 11 may readily be translated into the particular designs which they assume for any class of wave-filter with z_{1k} and z_{2k} known. For low pass, high pass, low-and-high pass and band pass wave-filters, the four most important classes, the actual physical arrangements and formulas for the inductances and capacities have been worked out. As a convenience in reference these designs are placed in Appendix II where all necessary formulas are given, making use of Appendix II of the paper mentioned in footnote 1. Little further discussion will be given here except to add the relations between U_k and frequency for these different classes, with dissipation neglected. By this means the characteristics which have been shown as functions of U_k may be referred to the frequency scale as the abscissa-axis, if desired in any particular case.

I.—Low Pass

$$U_k = - \left(\frac{f}{f_0} \right)^2, \quad (33)$$

and x_{1k} is made up of one positive branch.

II.—High Pass

$$U_k = - \left(\frac{f_1}{f} \right)^2, \quad (34)$$

and x_{1k} consists of one negative branch.

III.—Low-and-High Pass

$$U_k = - \frac{(f_1 - f_0)^2}{f_0 f_1} \frac{1}{\left(\frac{f_{1a}}{f} - \frac{f}{f_{1a}} \right)^2}, \quad (35)$$

where $f_{1a} = \sqrt{f_0 f_1}$, the anti-resonant frequency where $U_k = \infty$ and $x_{1k} = \infty$. For this class x_{1k} has a positive branch from 0 to f_{1a} and a negative branch from f_{1a} to ∞ .

IV.—Band Pass

$$U_k = - \frac{f_1 f_2}{(f_2 - f_1)^2} \left(\frac{f_{1r}}{f} - \frac{f}{f_{1r}} \right)^2, \quad (36)$$

where $f_{1r} = \sqrt{f_1 f_2}$, the mid-frequency or resonant frequency where $U_k = 0$ and $x_{1k} = 0$. Here x_{1k} is made up of a negative branch in the frequency range from 0 to f_{1r} and a positive branch from f_{1r} to ∞ .

2.5 Equivalent Structures

Many structures can be obtained which are externally equivalent to each of the above transducers; in fact, an infinite number is possible. That this is so can be seen from a consideration of the general transducers of Fig. 11, for example. It will not even be necessary to include the entire networks in this discussion but only the branches containing three impedances of two kinds, z_{1k} and z_{2k} . The branch containing one of z_{1k} in parallel with the series combination of one of z_{1k} and one of z_{2k} may be transformed completely by a well-known formula into one of z_{1k} in series with a parallel combination of one of z_{1k} and one of z_{2k} . No change in the number of impedance elements results and the magnitudes are fixed. If, however, an arbitrary part of the original parallel z_{1k} branch is kept out of the above transformation the final equivalent structure would have one more z_{1k} impedance and one more mesh than the original. The proportions of each impedance may obviously be varied continuously as the arbitrary division is so varied, thereby giving an infinite variety of magnitudes. This four impedance structure, equivalent to the original one, reduces at the limits to the two structures each having three fixed impedances, as we know. A similar process can be carried out with the shunt branch in the shunt

transducer which contains three impedances. In this case the series z_{2k} impedance of this branch would be arbitrarily divided and one part transformed by another well-known transformation with the parallel branch in series with it. The final result would be a z_{2k} in series with a parallel combination of a z_{2k} and series z_{1k} and z_{2k} ; that is, four impedances but no additional mesh. Here again the magnitudes would have a continuous range but at the limits with three impedances they are fixed. Other methods of transformations can be used on the network as a whole and most of the equivalents have more elements.

As a matter of interest a number of equivalents of the networks of Fig. 11 will be pointed out, all of which have the same minimum number of impedances. Starting with the transformations mentioned above, the latter series transducer has a star of z_{1k} impedances which may be transformed into a delta, thereby adding another mesh. Similarly the latter shunt transducer has a delta of z_{2k} impedances which may be given the form of a star which eliminates a mesh. Two other forms are given as V_1 and V_2 in Appendix II, being respectively equivalent to the series and shunt transducers. They are inverse networks just as are the originals in Fig. 11. In V_1 a still further transformation can be made from a star to a delta of z_{1k} impedances; in V_2 from a delta to a star of z_{2k} impedances. The possibility of obtaining the particular forms V_1 and V_2 was pointed out by H. W. Bode. I have derived them directly from the networks of Fig. 11 by a transformation of the major part of each network, using the simple formulas for the equivalent transducer transformations, respectively 1 and 2, of Appendix III.

The transformation formulas for these latter equivalent transducers in Appendix III are readily verified by the ordinary transformations from T to π networks, and vice versa.

In the higher class wave-filters which contain more than one element in z_{1k} and z_{2k} , transformations of only parts of z_{1k} and z_{2k} are also possible. For various other kinds of transformations see footnote 16 to Appendix III.

2.6 Terminal Losses at MM' -Type Terminations

When the terminal image impedance of a wave-filter is $W_{1k}(m, m')$ or $W_{2k}(m, m')$ and the wave-filter is terminated by a resistance R , there is a reflection loss at the junction due to the impedance irregularity which will be called the terminal loss $L_{m, m'}$. It is defined by the relations

$$e^{L_{m, m'}} = \left| \frac{R + W_{1k}(m, m')}{2\sqrt{RW_{1k}(m, m')}} \right| = \left| \frac{R + W_{2k}(m, m')}{2\sqrt{RW_{2k}(m, m')}} \right| \quad (37)$$

which are exactly analogous to formulas (33) and (34) of the paper cited here in footnote 2. Thus $L_{m,m'}$ may be plotted so as to give an additional chart for use in the method of calculating wave-filter transmission losses considered in that paper, which will apply when there are these kinds of MM' -type terminations. As a convenience a chart for $L_{m,m'}$ is given in Appendix IV for the particular values of the parameters $m = .7230$ and $m' = .4134$ already chosen in the fixed terminal transducers. To take account of dissipation several curves are shown for each one of which there is a different fixed relation between V_k and U_k . This chart, being an extension to the former set of charts, is numbered consecutively with the others as Chart 20. It shows that the terminal loss at R has two maxima beyond each critical frequency where $U_k = -1$. Their locations correspond to one resonant and one anti-resonant point of $W_{1k}(m, m')$ or $W_{2k}(m, m')$ in an attenuating band. Moreover, the position of the first and lowest maximum coincides with that of the maximum attenuation of the terminating wave-filter, the MM' -type, while the position of the second coincides with that of the maximum attenuation of the related M -type. (An M -type termination gives only the first maximum; an $MM'M''$ -type gives three maxima, etc.) The transmission unit, the Neper, is the same as that which was called the *attenuation unit* on the previous charts. The corresponding number of decibels is obtained by multiplying the number of Nepers by 8.686.

When such a termination is used the interaction loss is practically negligible.

PART 3. SIMULATION OF WAVE-FILTER IMPEDANCES

So far the two networks of Fig. 11 have been considered only from the standpoint of their use as terminal wave-filter transducers with desirable propagation and image impedance characteristics. While this is their major purpose they can have a minor use to be shown here, namely, as parts of two-terminal networks whose purpose is to simulate wave-filter impedances where such networks may be desired. This possibility is suggested by the fact that the image impedances at the final terminals are approximately equal to a constant resistance in all transmitting bands which can be simulated at these frequencies by a simple resistance R . It follows that if each pair of final terminals is terminated by a resistance R , the impedances at the two remaining pairs of terminals will be approximately equal to their image impedances, W_{1k} and W_{2k} , respectively, in the transmitting bands. Moreover, on account of the high attenuation of the transducers in the attenuating bands which reduces transmission through them, the large impedance irregularities at those frequencies between each network

and its terminating resistance R will produce only a small effect upon the impedances at the other terminals. As a result the latter impedances will be approximately equal to W_{1k} and W_{2k} in the attenuating bands also. Higher order transducers might also be used.¹³

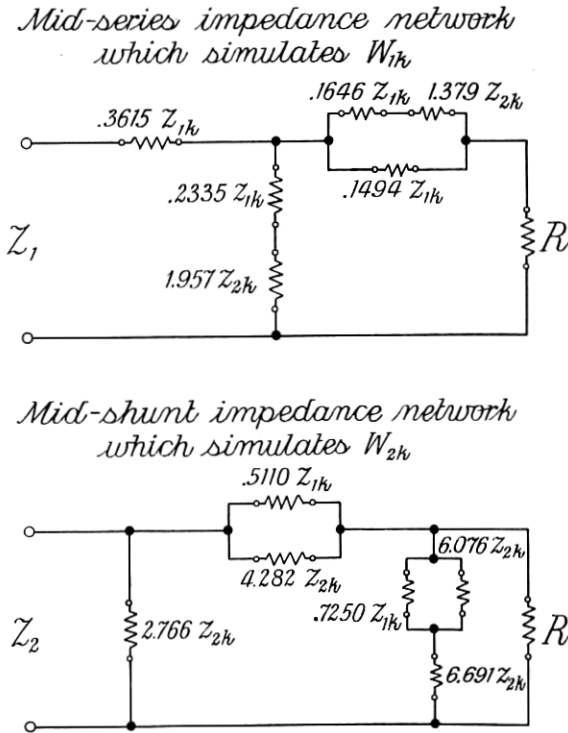

Fig. 15—Impedance networks which simulate the image impedances, W_{1k} and W_{2k} , of "constant k " and related wave-filters of any class.

With this explanation of their origin the general impedance networks of Fig. 15 have been assembled. One of impedance Z_1 simulates the image impedance W_{1k} ; the other of impedance Z_2 , the image impedance W_{2k} . The degree of simulation attained can be seen from the characteristics of Fig. 16, wherein the effect of small dissipation is included by assuming $V_k = +.01U_k$ in a negative branch and $V_k = -.01U_k$ in a positive branch, as before. Over most of a transmitting band the agreement is within a few per cent; outside it is still quite satisfactory. Near the critical frequencies, where

¹³ Still other forms of networks have been considered by R. Feldtkeller in a paper "Über einige Endnetzwerke von Kettenleitern," *Elektrische Nachrichten-Technik*, Band 4, Heft 6, p. 253, 1927.

$U_k = -1$, the simulation is improved by dissipation, as we might expect.

This physical possibility of closely simulating the image impedance of a wave-filter shows that the assumption of such a physical termination, as made in a previous paper,¹⁴ was practically justified when solving the problem of the behavior of wave-filters under non steady-state conditions.

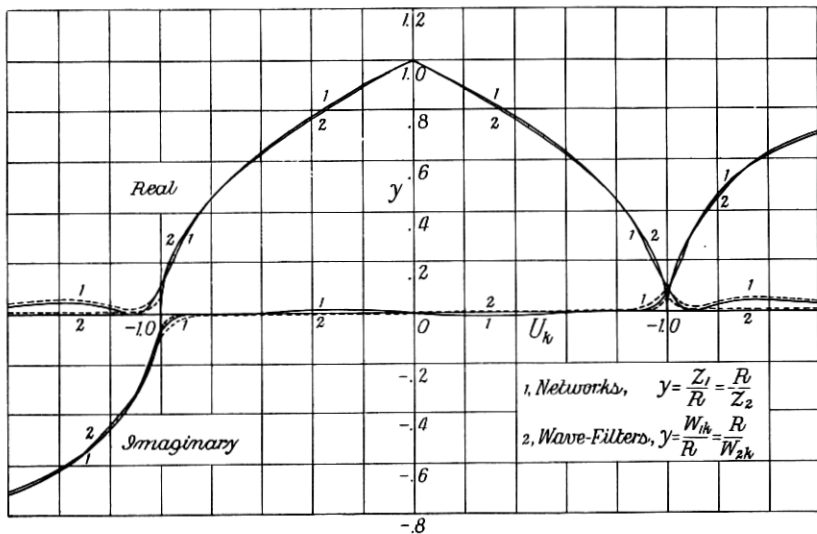

Fig. 16—Simulation of the image impedances W_{1k} and W_{2k} by the impedance networks of Fig. 15. (Broken lines are for dissipation with $V_k = \pm .01 U_k$).

The particular structures for simulating the impedances of "constant k " low pass, high pass, low-and-high pass and band pass wave-filters, which correspond to the general ones of Fig. 15, are obtained by terminating the networks of Appendix II with resistances R . It is understood, of course, that others than the "constant k " wave-filter of any class have either the image impedance W_{1k} or W_{2k} . Obviously, it would be possible to simulate the impedance of any wave-filter which by proper combination on the image basis can be linked with these networks simulating W_{1k} or W_{2k} . This, therefore, gives a method for obtaining in a limited frequency range or ranges almost any resistance characteristic with zero reactance.

Likewise, the impedance of a mid-series section of the shunt MM' -type or a mid-shunt section of the series MM' -type which has the parameters of formula (32) and one pair of its terminals closed by a

¹⁴ "Transient Oscillations in Electric Wave-Filters," J. R. Carson and O. J. Zobel, *B. S. T. J.*, July, 1923.

resistance R , is a good simulation of $W_{1k}(m, m')$ or $W_{2k}(m, m')$. The latter are, as we know, approximately constant resistances equal to R over desired frequency ranges and are reactances at other frequencies. An interesting use of either or both of these simulating networks would be as a balancing network against a resistance R or against each other in a hybrid set. At frequencies in those ranges where the balance is quite accurate, currents in the main circuit would be highly attenuated, these attenuating bands corresponding to the transmitting bands of the wave-filter impedance section.

PART 4. SIMULATION OF LOADED LINE IMPEDANCES

The networks of Fig. 17 are capable of giving impedance simulation over the greater part of the principal transmitting band of a

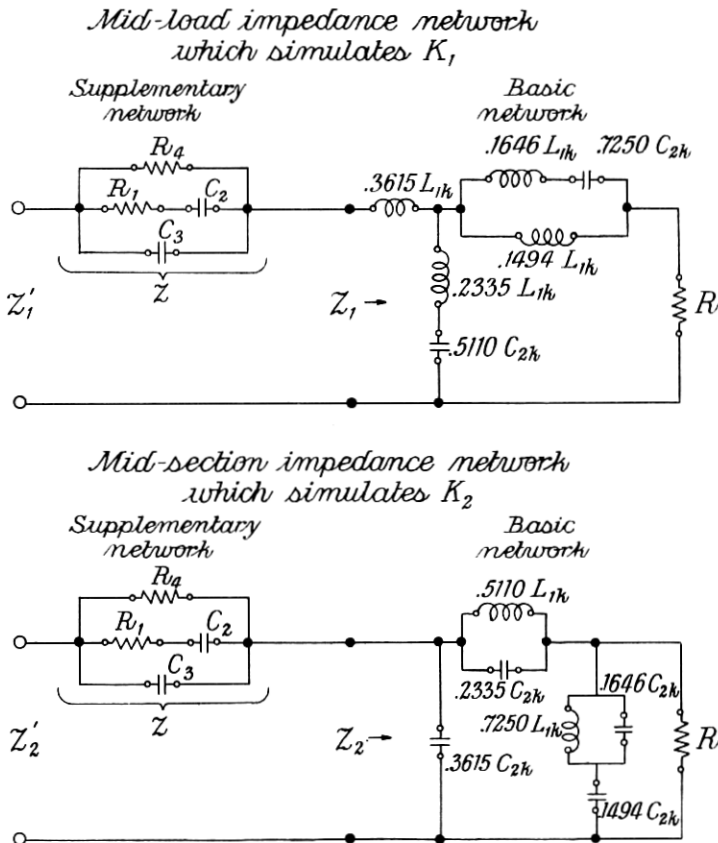

Fig. 17—Impedance networks which simulate the iterative impedances, K_1 and K_2 , of a loaded line at mid-load and mid-section terminations, respectively.

loaded line. They are useful in cases where it is desirable to extend nearer the critical frequency the range of simulation possible by means of the networks described by R. S. Hoyt.¹⁵

Designs are given for mid-load and mid-section terminations. Results for other terminations can be obtained by building out the load or section. From an economic standpoint it might be pointed out that the basic networks for the mid-point impedances to be described each have seven elements, whereas corresponding designs based upon Figs. 14 and 15 of Hoyt's paper would have six elements. However, the new mid-load basic network which extends the range of simulation requires only one-half the total amount of capacity but slightly more inductance than that required by the corresponding Hoyt network; the new mid-section basic network requires only one-half the total amount of inductance but slightly more capacity than the corresponding Hoyt network.

4.1 Foundation of Designs

The design of any simulating network usually involves two processes, namely, a determination first of structural form and second of magnitudes.

The structural forms of the new designs follow readily from the well-justified assumption that either mid-point impedance of a loaded line in its principal transmitting band is approximately equal to the corresponding mid-point impedance of a "constant k " low pass wave-filter as the basic network, with the series addition of the impedance of a supplementary network which simulates the additional impedance introduced by dissipation at low frequencies. While this assumption is really the same one which underlies the designs by Hoyt, the new basic networks have considerably different forms and were derived from wave-filter theory, which explains their inclusion in this paper. In fact, the desired basic networks of Fig. 17 are immediately available from the results of Part 3, being special cases of the networks of Fig. 15 which use the low pass wave-filters of Appendix II.

The particular supplementary network chosen, one already considered by Hoyt but designed differently, has four elements, two resistances and two capacities, and is known to have the desired impedance characteristic. The same one will generally do for either mid-load or mid-section impedance, as it contributes impedance only at the lower frequencies of the range.

The magnitudes of the elements of these networks are all determined

¹⁵ "Impedance of Loaded Lines, and Design of Simulating and Compensating Networks," R. S. Hoyt, *B. S. T. J.*, July, 1924.

from computed loaded line impedances (or perhaps from measured impedances), instead of directly from certain primary line and coil data. This makes it comparatively easy to take account of variations with frequency of the constants, such as line leakage and loading coil resistance.

The mid-load iterative impedance is given by the formula

$$K_1 = k \sqrt{\left(1 + \frac{z_L}{2k} \tanh \frac{S\gamma}{2}\right) \left(1 + \frac{z_L}{2k} \coth \frac{S\gamma}{2}\right)}; \quad (38)$$

the mid-section iterative impedance by

$$K_2 = k \sqrt{\frac{1 + \frac{z_L}{2k} \coth \frac{S\gamma}{2}}{1 + \frac{z_L}{2k} \tanh \frac{S\gamma}{2}}}. \quad (39)$$

In these formulas γ and k are the propagation constant and iterative impedance, respectively, of the non-loaded line which may be computed on the basis that the shunt capacity of each loading coil and its leads is assumed to be concentrated, half at each end, and that each half is added in the formulas to the line capacity of the adjacent section. S is the load spacing and z_L the load impedance.

4.2 Mid-Load Basic Network

This basic network has the structure and general design shown in the upper part of Fig. 17. The magnitudes of its elements are fixed when R and f_0 are known, since

$$L_{1k} = R/\pi f_0, \quad (40)$$

and

$$C_{2k} = 1/\pi f_0 R;$$

where R is the impedance $\sqrt{L_{1k}/C_{2k}}$ and f_0 is the critical frequency. Its impedance in the frequency range considered is quite accurately given by

$$Z_1 \approx R \sqrt{1 - \left(\frac{f}{f_0}\right)^2} = r, \quad (41)$$

which relation will be used for design purposes. The values of R and f_0 are here determined for any particular loaded line by assuming that at two frequencies, f_a and f_b , the corresponding values of r , respectively r_a and r_b , are equal to the resistance components of K_1 as computed at those frequencies from (38). The frequencies f_a and f_b are chosen in

the upper part of the desired range where the reactance components of K_1 are small. Substitution of these values in (41) gives two linear equations in R^{-2} and f_0^{-2} from which

$$R = r_a \sqrt{\frac{1 - \left(\frac{f_a r_b}{f_b r_a}\right)^2}{1 - \left(\frac{f_a}{f_b}\right)^2}},$$

(42)

and

$$f_0 = f_b \sqrt{\frac{1 - \left(\frac{f_a r_b}{f_b r_a}\right)^2}{1 - \left(\frac{r_b}{r_a}\right)^2}}.$$

The actual impedance, Z_1 , of the network with these values may be computed as for any finite network.

4.3 Mid-Section Basic Network

This network in the lower part of Fig. 17 is the mid-shunt simulating network corresponding to Fig. 15.

Its impedance in the desired range is approximately given by the formula

$$Z_2 \approx \frac{R}{\sqrt{1 - \left(\frac{f}{f_0}\right)^2}} = r. \quad (43)$$

To determine R and f_0 , assume two values of r to be equal to r_a and r_b , the resistance components of K_2 as computed from (39) at two frequencies f_a and f_b , where the reactance components of K_2 are small. Then from (43) we obtain two linear equations in R^2 and f_0^{-2} from which

$$R = r_a \sqrt{\frac{1 - \left(\frac{f_a}{f_b}\right)^2}{1 - \left(\frac{f_a r_a}{f_b r_b}\right)^2}},$$

(44)

and

$$f_0 = f_b \sqrt{\frac{1 - \left(\frac{f_a r_a}{f_b r_b}\right)^2}{1 - \left(\frac{r_a}{r_b}\right)^2}}.$$

The actual impedance of this network is Z_2 . The values of R and f_0 from (44) will be practically the same as those from (42).

4.4 Supplementary Network

Shown in both simulating networks of Fig. 17, this network has an impedance expression of the form

$$z = \frac{a_0 + a_1if}{1 + b_1if - b_2f^2} = r + ix, \quad (45)$$

where

$$a_0 = R_4,$$

$$a_1 = 2\pi R_1 R_4 C_2,$$

$$b_1 = 2\pi(R_1 C_2 + R_4 C_2 + R_4 C_3),$$

and

$$b_2 = 4\pi^2 R_1 R_4 C_2 C_3.$$

The resistance and capacity elements are obtained from the above impedance coefficients as

$$R_1 = a_0 a_1^2 / (a_0 a_1 b_1 - a_0^2 b_2 - a_1^2),$$

$$C_2 = (a_0 a_1 b_1 - a_0^2 b_2 - a_1^2) / 2\pi a_0^2 a_1,$$

$$C_3 = b_2 / 2\pi a_1, \quad (46)$$

and

$$R_4 = a_0.$$

From (45) the pair of *impedance linear equations* is

$$a_0 + fxb_1 + f^2rb_2 = r,$$

and

$$fa_1 - frb_1 + f^2xb_2 = x. \quad (47)$$

With the above formulas we can proceed to indicate the method of design.

Ideally the network should have the impedance characteristic

$$z = r + ix = K_1 - Z_1, \quad (48)$$

or

$$z = r + ix = K_2 - Z_2, \quad (49)$$

depending upon which mid-point impedance, K_1 or K_2 , is being simulated. Usually these two values of z are practically the same. To fix the four impedance coefficients, assume that the network has the ideal components of (48) or (49) at two important low frequencies, the data with increasing frequency being,

$$f_1, \quad r_1 + ix_1;$$

and

$$f_2, \quad r_2 + ix_2.$$

These values are to be substituted in (47) to obtain four linear equations. The solution of these linear equations gives

$$\begin{aligned} a_0 &= r_1 - f_1 x_1 b_1 - f_1^2 r_1 b_2, \\ a_1 &= r_1 b_1 - f_1 x_1 b_2 + x_1 / f_1, \\ b_1 &= \frac{f_1 f_2 (f_1 x_1 - f_2 x_2) (r_1 - r_2) + (f_1 x_2 - f_2 x_1) (f_1^2 r_1 - f_2^2 r_2)}{D}, \quad (50) \\ b_2 &= \frac{f_1 f_2 (r_1 - r_2)^2 + (f_1 x_1 - f_2 x_2) (f_2 x_1 - f_1 x_2)}{D}, \end{aligned}$$

where

$$D = f_1 f_2 \{ (f_1^2 r_1 - f_2^2 r_2) (r_1 - r_2) + (f_1 x_1 - f_2 x_2)^2 \}.$$

From the values of a_0 , a_1 , b_1 , and b_2 the network constants can be computed by formulas (46). The network impedance is then given at any frequency by formula (45).

The actual impedance simulating K_1 is the sum, $Z_1' = Z_1 + z$; that simulating K_2 is the sum, $Z_2' = Z_2 + z$.

It should be pointed out here that the supplementary network may, if desired, be given other structural forms having two resistances and two capacities and having an equivalent impedance characteristic. These other forms may be obtained by transformations from the known one above or their elements determined from other formulas corresponding to those of (46).

Likewise, a supplementary network which has a smaller or larger number of elements than the one above might be used satisfactorily with the same basic networks or their equivalents. That depends upon the low-frequency impedance characteristics of the given loaded line and upon the closeness of simulation desired.

4.5 Application of Results

To illustrate the possibilities of these impedance networks, mid-load and mid-section designs are given here for a 19-gauge B-88-50 loaded side-circuit. The "B" spacing is $S = .568$ mile (3000 feet).

Data for the mid-load basic network, taken from computations of K_1 , are

$$f_a = 3000, \quad r_a = 1324;$$

and

$$f_b = 5000, \quad r_b = 720.$$

These give from (42), $R = 1564.4$ ohms, and $f_0 = 5632$ cycles per second.

Data for the mid-section basic network, taken from computations

of K_2 , are

$$f_a = 3000, \quad r_a = 1848;$$

and

$$f_b = 5000, \quad r_b = 3387.$$

Then from (44), $R = 1564.6$ ohms, and $f_0 = 5638$ cycles per second. Because of the close agreement between these two sets of results, their approximate mean values will here be used in both basic networks, namely

$$R = 1565 \text{ ohms,}$$

and

$$f_0 = 5635 \text{ cycles per second.}$$

With these values in (40), $L_{1k} = 88.38$ mh., and $C_{2k} = .03611$ mf. We have then for the *mid-load basic network* the inductance and capacity elements:

$$\begin{array}{ll} .3615 L_{1k} = 31.95 \text{ mh.}; & .2335 L_{1k} = 20.64 \text{ mh.}; \\ .1646 L_{1k} = 14.55 \text{ mh.}; & .1494 L_{1k} = 13.20 \text{ mh.}; \\ .5110 C_{2k} = .01845 \text{ mf.}; & .7250 C_{2k} = .02618 \text{ mf.}; \end{array}$$

and for the *mid-section basic network*

$$\begin{array}{ll} .5110 L_{1k} = 45.16 \text{ mh.}; & .7250 L_{1k} = 64.08 \text{ mh.}; \\ .3615 C_{2k} = .01305 \text{ mf.}; & .2335 C_{2k} = .008431 \text{ mf.}; \\ .1646 C_{2k} = .005943 \text{ mf.}; & .1494 C_{2k} = .005395 \text{ mf.}; \end{array}$$

with their locations as in Fig. 17.

The impedance characteristics of these basic networks, Z_1 and Z_2 , were computed directly from the finite networks on the assumption of small coil and condenser dissipation constants, $d = d' = .005$. Comparatively small reactance components begin to appear above 4500 cycles per second. Increasing the amount of dissipation in the reactance elements would tend to increase the reactance components of Z_1 and Z_2 at the upper frequencies.

The design of the single supplementary network was made from low frequency data representing the average values of $(K_1 - Z_1)$ and $(K_2 - Z_2)$. The data are

$$f_1 = 100, \quad r_1 + ix_1 = 152 - i700,$$

and

$$f_2 = 300, \quad r_2 + ix_2 = 20 - i252.$$

From formulas (50) we obtain

$$\begin{array}{ll} a_0 = 7839.0; & a_1 = 233.12; \\ b_1 = 17.600 \cdot 10^{-2}; & b_2 = 30.481 \cdot 10^{-4}. \end{array}$$

From (46) these give

$$\begin{aligned} R_1 &= 5327 \text{ ohms}; & C_2 &= .8886 \text{ mf.}; \\ C_3 &= 2.081 \text{ mf.}; & R_4 &= 7839 \text{ ohms.} \end{aligned}$$

The impedance characteristic above 100 cycles per second as computed from formula (45) is mostly that of negative reactance, both components decreasing rapidly with frequency.

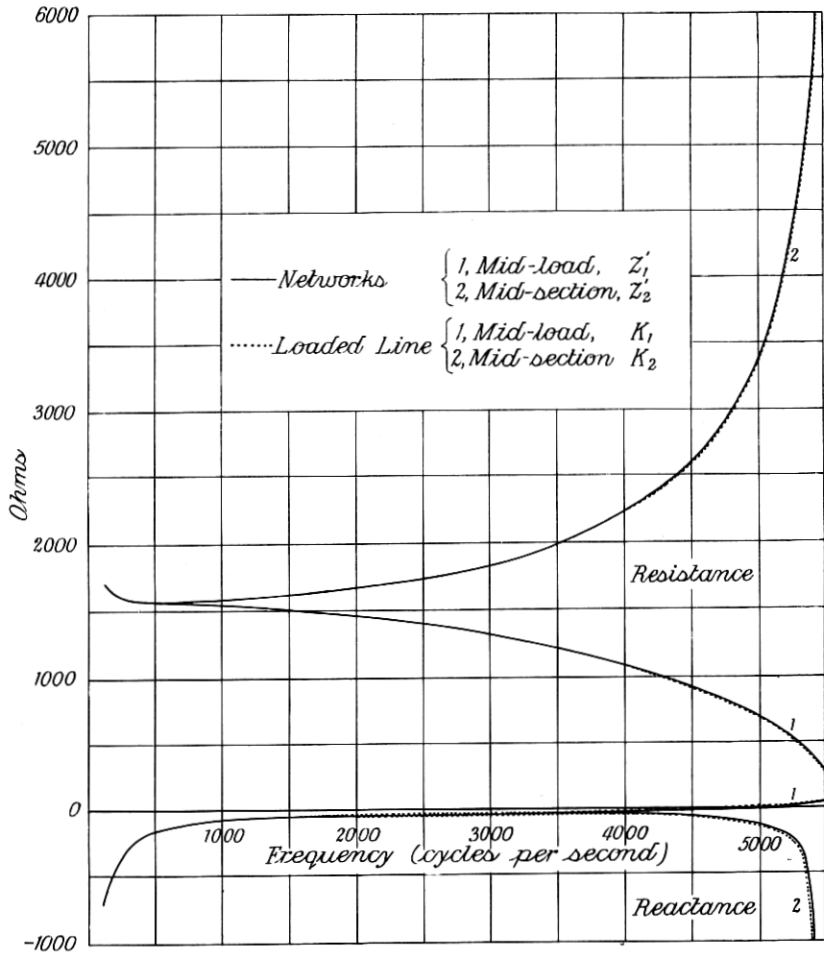

Fig. 18—Simulation of the iterative impedances, K_1 and K_2 , of a 19-Ga. B-88-50 loaded side-circuit by the impedance networks of Fig. 17. (Coil and condenser dissipation constants are $d = d' = .005$.)

Final results showing the characteristics of the complete simulating networks are compared with those of the loaded line in Fig. 18.

Simulation is within .7 per cent of the impedance over the continuous range from 100 to 3000, within 2 per cent from 3000 to 5000, and within 4 per cent from 5000 to 5500 cycles per second; the per cent accuracy is best in the case of the mid-section network. This upper frequency is approximately 97 per cent of the critical frequency, 5635 cycles per second. There is good simulation even considerably beyond the critical frequency, as may be inferred from Fig. 16.

For still greater precision, networks which originally have three or more parameters and which are formed in a manner similar to those of Fig. 15 may constitute the basic networks.

4.6 Other Approximate Designs

Alternative designs of networks simulating K_1 and K_2 can be made with the networks of Fig. 15 as foundations. The method of doing this will merely be outlined here since the networks do not appear to be as practical as the ones already described in detail.

This procedure assumes that the actual loaded line structure can be quite accurately represented physically in the desired frequency range by a ladder structure of series and shunt impedances, z_1 and z_2 , respectively. Roughly, z_1 would be series resistance and inductance and z_2 would be parallel resistance and capacity. Then throughout the two networks of Fig. 15 the impedance of z_{1k} is to be replaced by that of z_1 and the impedance of z_{2k} by that of z_2 . Also the terminating resistance R is to be replaced by $\sqrt{z_1 z_2}$, the impedance of the corresponding uniform line, which in this case might be approximately simulated by a resistance in series with a network like the supplementary network of Fig. 17. The resulting impedance networks would then approximately represent K_1 and K_2 . However, no design formulas are needed to show that even if these networks give as good simulation as the networks of Fig. 17 they would require more elements.

APPENDIX I

Reactance Frequency Theorems and Proofs of Frequency Relations in M-Type or Higher Order Wave-Filters

There are certain simple frequency relations which hold in the reactance characteristics of non-dissipative impedances. A statement and proof of these relations will first be given. From them will follow readily the proofs of the frequency relations in the characteristics of M -type or higher order wave-filters, which are represented by formulas (20) to (24), since they require a consideration of the "constant k " series impedance z_{1k} only.

Reactive Impedance Characteristics

All non-dissipative impedances have reactances which can be separated into four forms of impedance functions, each of which can be expressed as the ratio of two frequency-polynomials in if , where $i = \sqrt{-1}$, and f is frequency. It is known that such a reactance necessarily has a positive slope with frequency and hence the resonant and anti-resonant frequencies alternate on the frequency scale. The four mathematical forms may be separated on the basis of the general location of their resonant frequencies and have finite resonant frequencies with or without zero and infinite resonant frequencies. These reactive impedance forms are as follows:

Form 1. Resonant at zero and n finite frequencies.

$$z = \frac{a_1 if + a_3 (if)^3 + \dots + a_{2n+1} (if)^{2n+1}}{1 + b_2 (if)^2 + \dots + b_{2n} (if)^{2n}} = ix. \quad (51)$$

Form 2. Resonant at n finite and infinite frequencies.

$$z = \frac{1 + a_2 (if)^2 + \dots + a_{2n} (if)^{2n}}{b_1 if + b_3 (if)^3 + \dots + b_{2n+1} (if)^{2n+1}} = ix. \quad (52)$$

Form 3. Resonant at zero, n finite and infinite frequencies.

$$z = \frac{a_1 if + a_3 (if)^3 + \dots + a_{2n+1} (if)^{2n+1}}{1 + b_2 (if)^2 + \dots + b_{2n+2} (if)^{2n+2}} = ix. \quad (53)$$

Form 4. Resonant at n finite frequencies.

$$z = \frac{1 + a_2 (if)^2 + \dots + a_{2n} (if)^{2n}}{b_1 if + b_3 (if)^3 + \dots + b_{2n-1} (if)^{2n-1}} = ix. \quad (54)$$

Each of these forms has a simple frequency relation which is expressible as a theorem.

Reactance Frequency Theorems

The product F of the frequencies at which the reactance x is $\pm c$ in each of the four reactive impedance forms is the following:

Form 1. $F_{2n+1} = \frac{c}{a_{2n+1}}$, proportional to c .

Form 2. $F_{2n+1} = \frac{1}{cb_{2n+1}}$, inversely proportional to c .

Form 3. $F_{2n+2} = \frac{1}{b_{2n+2}}$, independent of c .

When $c = \infty$, meaning anti-resonance of z , each anti-resonant frequency appears twice in the product.

Form 4.
$$F_{2n} = \frac{1}{a_{2n}}, \text{ independent of } c.$$

When $c = 0$, meaning resonance of z , each resonant frequency appears twice in the product.

To prove the theorem for Form 1 first square the expression in (51) and clear the fraction. This gives a polynomial in f^2 of degree $2n + 1$, of which only the terms of highest and zero powers need be shown for our purpose. Thus

$$(f^2)^{2n+1} + \dots - \frac{x^2}{a_{2n+1}^2} = 0, \quad (55)$$

which expresses the general relationship between x^2 and f^2 . If x^2 is given some constant value as $x^2 = c^2$, that is $x = \pm c$, the roots of (55) will be the $2n + 1$ distinct values of f^2 where $x = \pm c$. By the theory of equations, the product of these $2n + 1$ values of f^2 is (c^2/a_{2n+1}^2) . Since we are interested only in positive frequencies, we may take the positive square root of both sides with the result that the product of all frequencies at which $x = \pm c$ is c/a_{2n+1} , which proves the theorem.

The proofs of the theorems for Forms 2, 3 and 4 are exactly similar and should not need further explanation. In Form 3 the values $x = \pm \infty$ occur at the anti-resonant frequencies of z , namely f_{1a}, f_{2a} , etc.; hence, when $c = \infty$ the total frequency product includes each of the latter frequencies twice. The result for Form 4 has a meaning even at the limit $c = 0$. These frequencies are the resonant ones of z , where $z = 0$, and each one of them must obviously appear twice in the total product.

Proofs of Wave-Filter Frequency Relations

As was stated in Section 1.9, z_{1k} satisfies certain conditions at the particular frequencies of interest.

At critical frequencies, f_0, f_1 , etc.,

$$z_{1k} = \pm i2R. \quad (56)$$

At frequencies of infinite attenuation, $f_{0\infty}, f_{1\infty}$, etc.,

$$z_{1k} = \pm \frac{i2R}{\sqrt{1 - g^2}}. \quad (57)$$

Every negative or positive branch of z_{1k} includes one each of these frequencies.

For those wave-filters with only internal transmitting bands the additional relation will be used which specifies the frequencies where all image impedances equal R and the series impedances become resonant. At these resonant frequencies, f_{1r} , f_{2r} , etc., in the transmitting bands

$$z_{1k} = 0. \quad (58)$$

We know that in a "constant k " wave-filter the transmitting bands include the frequencies at which the series impedance z_{1k} is resonant. Hence, to the four forms of impedance function for z_{1k} , as in (51) to (54), there correspond four groups of wave-filter classes as already mentioned. These groups were designated according to the general locations of their transmitting bands which obviously correspond to the locations of the resonant frequencies of z_{1k} . For this reason each wave-filter group and the corresponding impedance form of z_{1k} have the same number designation.

Group 1. Low-and- n Band Pass.

An application of the theorem for Form 1 with (56) and (57) gives immediately the desired relation (20)

$$f_{0\infty} f_{1\infty} \cdots f_{2n\infty} = \frac{1}{\sqrt{1-g^2}} f_0 f_1 \cdots f_{2n}.$$

Similarly the relations (21), (22) and (23) are obtained for Groups 2, 3 and 4. Relation (24) for Group 4 is derived from (56) and (58), the latter corresponding to $c = 0$ in the theorem for Form 4 where each resonant frequency appears twice; the square root of the resulting relation is (24).

APPENDIX II

Fixed Terminal Transducers of Several Wave-Filter Classes

I. Low Pass.

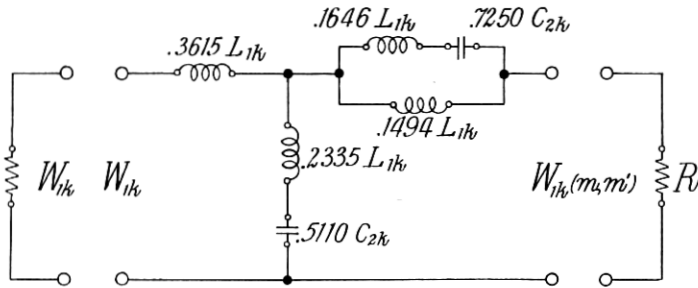
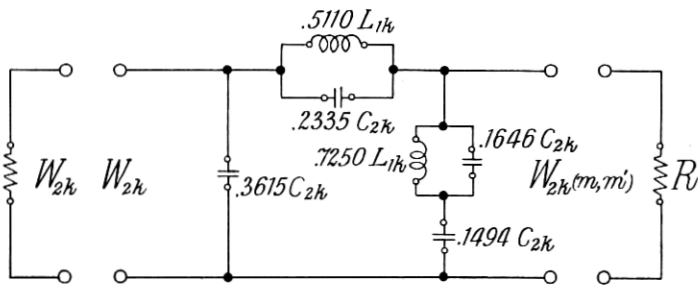
I₁-Series terminal transducer*I₂-Shunt terminal transducer*

$$L_{1k} = \frac{R}{\pi f_0}, \quad C_{2k} = \frac{1}{\pi f_0 R}.$$

II. High Pass.

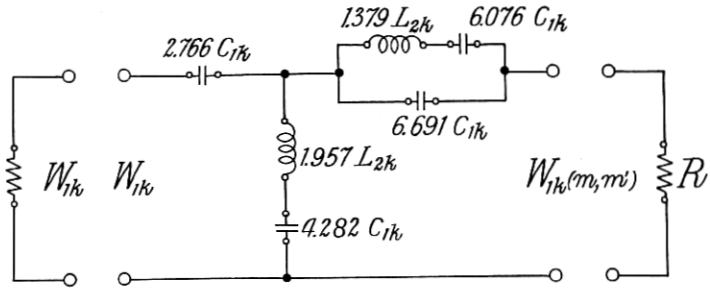
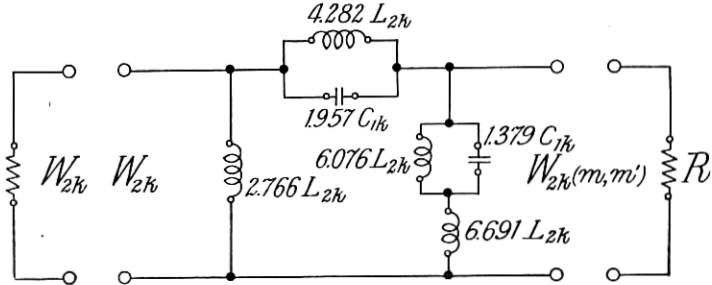
II₁-Series terminal transducer*II₂-Shunt terminal transducer*

$$C_{1k} = \frac{1}{4\pi f_1 R}, \quad L_{2k} = \frac{R}{4\pi f_1}.$$

III. Low-and-High Pass.

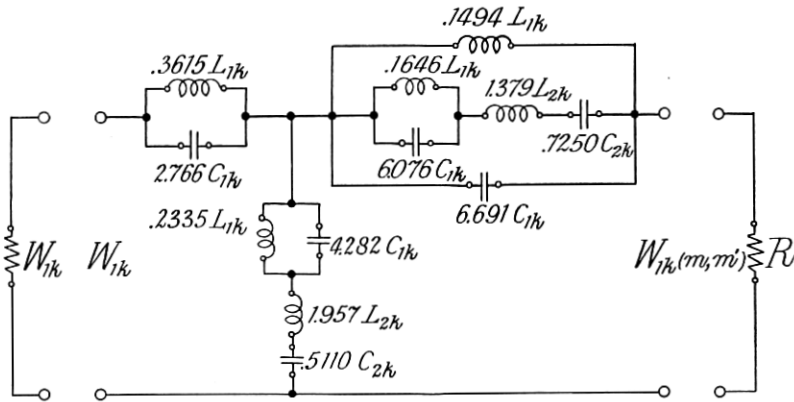
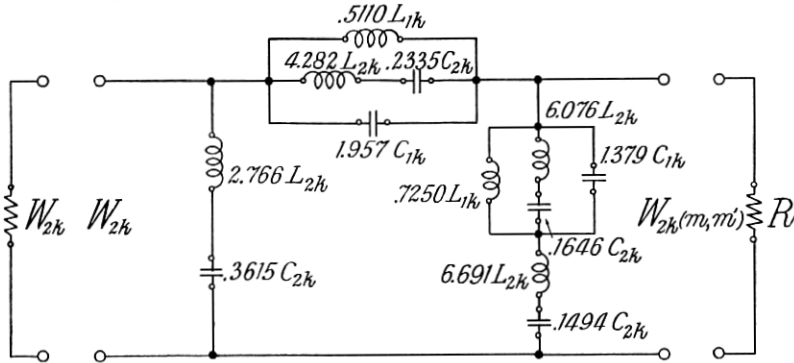
III₁-Series terminal transducer*III₂-Shunt terminal transducer*

$$L_{1k} = \frac{(f_1 - f_0)R}{\pi f_0 f_1}, \quad L_{2k} = \frac{R}{4\pi(f_1 - f_0)},$$

$$C_{1k} = \frac{1}{4\pi(f_1 - f_0)R}, \quad C_{2k} = \frac{f_1 - f_0}{\pi f_0 f_1 R}.$$

IV. Band Pass.

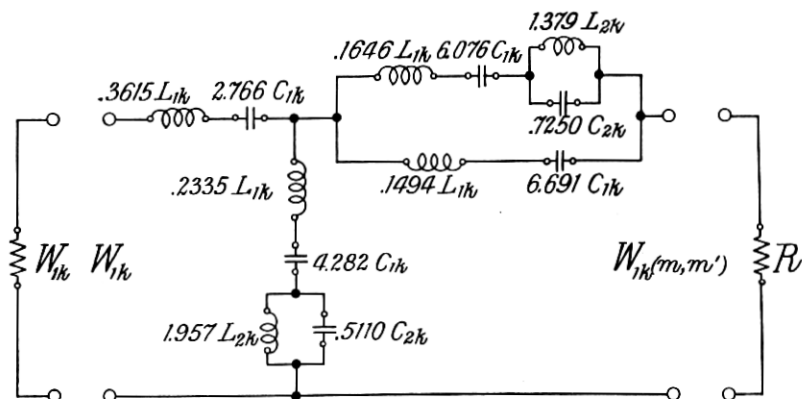
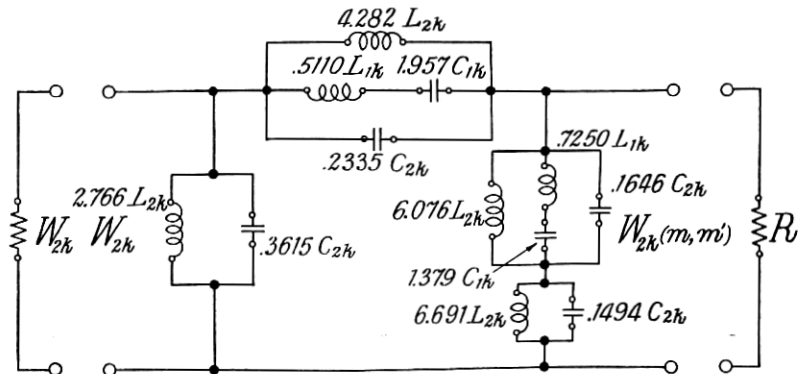
IV₁-Series terminal transducer*IV₂-Shunt terminal transducer*

$$L_{1k} = \frac{R}{\pi(f_2 - f_1)},$$

$$L_{2k} = \frac{(f_2 - f_1)R}{4\pi f_1 f_2},$$

$$C_{1k} = \frac{f_2 - f_1}{4\pi f_1 f_2 R},$$

$$C_{2k} = \frac{1}{\pi(f_2 - f_1)R}.$$

V. Equivalents of Fixed Terminal Transducers of Fig. 11.

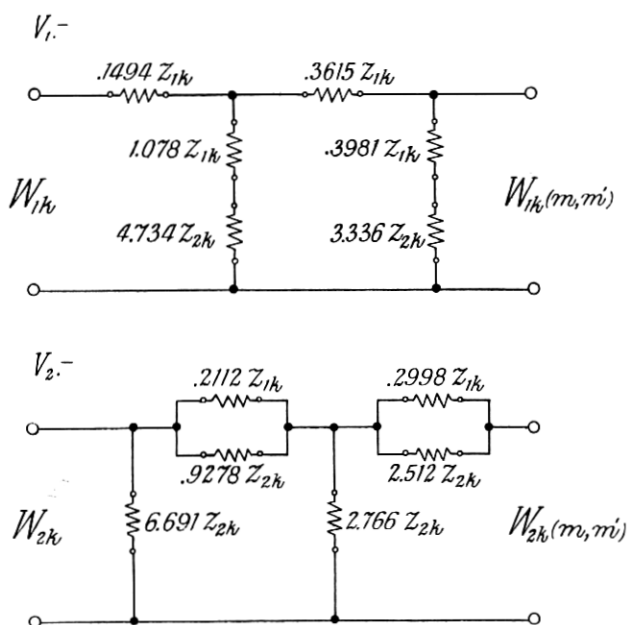

APPENDIX III

Equivalent Transducers and Transformation Formulas¹⁶

Transformation 1

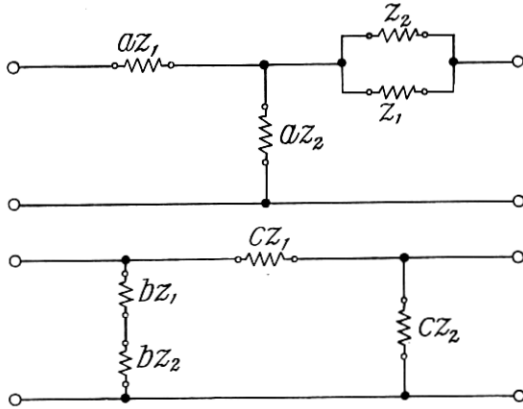

Equivalent when

$$b = a(1 + a), \quad c = 1 + a.$$

Transformation 2

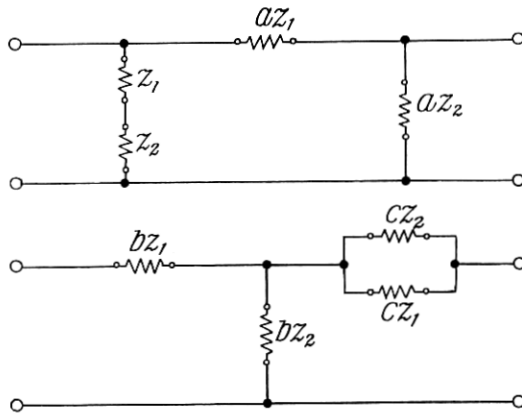

Equivalent when

$$b = \frac{a}{1 + a}, \quad c = \frac{a^2}{1 + a}.$$

¹⁶ For transformations of simple equivalent two-terminal or impedance networks containing two kinds of general impedances, see Appendix III of paper in footnote 1. Also U. S. Patent No. 1,644,004 to O. J. Zobel, dated October 4, 1927.

Terminal Losses at Fixed MM'-Type Terminations

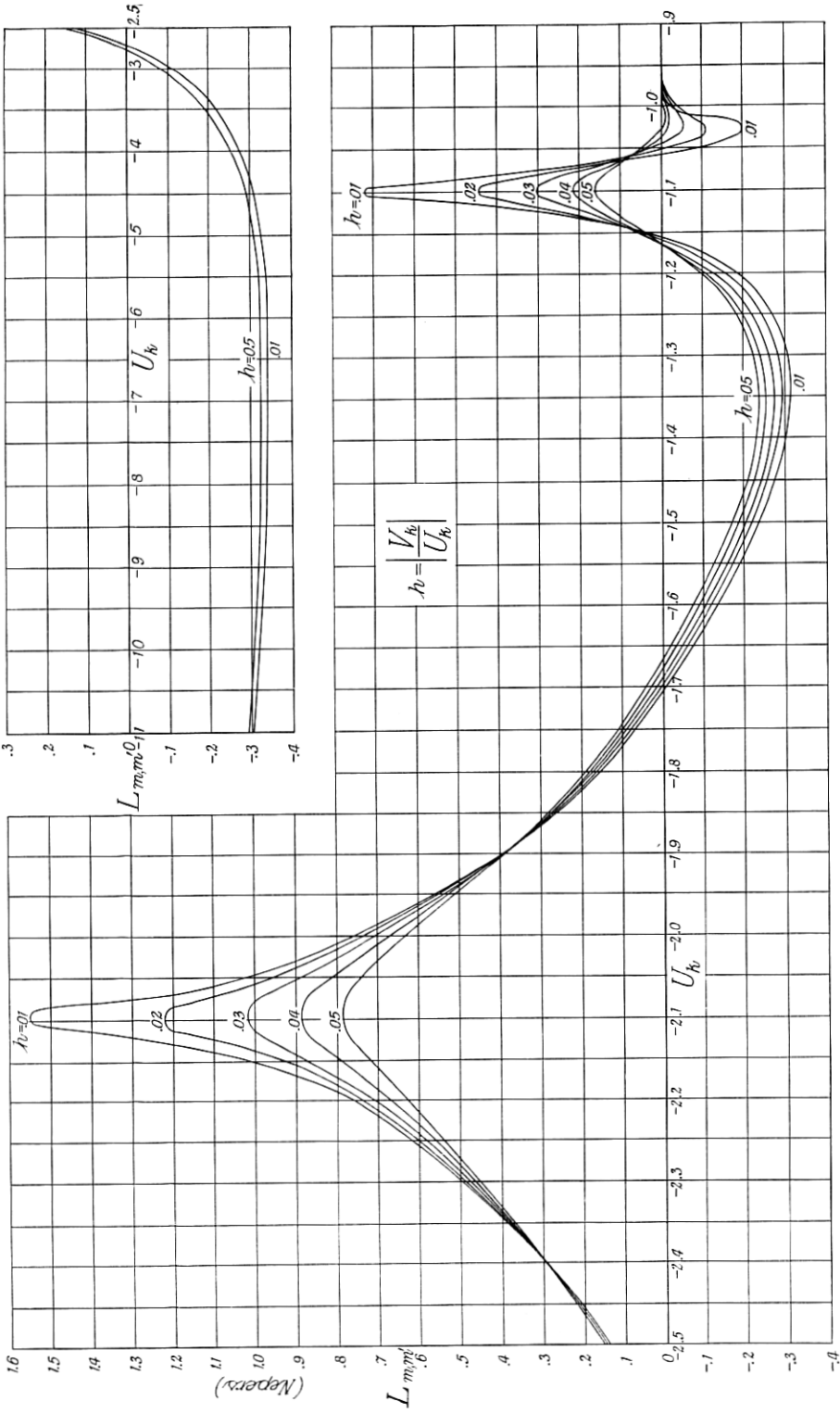

Chart 20.— $L_{m,m'}$ for $m = .7230$ and $m' = .4134$.