

Effect of Signal Distortion on Morse Telegraph Transmission Quality

By J. HERMAN

In applying telegraph transmission measuring apparatus to the development and maintenance of telegraph circuits, it is desirable to correlate quantitative measurements of telegraph signal distortion with quality of telegraph transmission. Accordingly, a series of tests has been carried out in order to determine this relationship for the case of manual operation using the American Morse Code. These tests are described and the results, together with the conclusions reached, are given in summarized form.

I. INTRODUCTION

WHENEVER telegraph signals are transmitted over a circuit they become more or less distorted depending upon the type of circuit, the adjustment of the apparatus and the speed of transmission. An adequate knowledge of the relationship between the possible types of distortion and the satisfactoriness of the telegraph services rendered over various circuits is evidently of considerable importance. This is true both in the design of telegraph circuits to insure the necessary quality of transmission and in the operation and maintenance of these circuits to insure that they are giving the service for which they are designed.

Considerable data both qualitative and quantitative, bearing on this matter have been collected in the past in connection with development work and as a result of operating experience in the Bell System. Recently some tests were made to correlate quality of telegraph transmission with quantitative measurements of signal distortion on manual telegraph circuits employing the American Morse code. This paper presents and discusses the results of these tests.

Commercial telegraph operation over land lines in the United States, is carried on almost exclusively by two well known methods, manual Morse and printing telegraph. In the first method, the signals are sent by hand in accordance with the Morse code and received by ear by listening to the clicking of a sounder. In the second method, the signals are sent mechanically under the control of a typewriter keyboard and received so as to cause the selection and printing of the proper character by mechanical means. Although the question of permissible distortion in transmission is of importance for both methods, it is to be expected that the answer will be considerably more involved for the manual Morse case since the human element is so large a factor in this case.

II. DESCRIPTION OF TESTS

1. *Preliminary Considerations*

Telegraph transmission quality may be considered perfect when the received signals at one end of the circuit correspond exactly to the signals as sent at the other end of the circuit. Any departure in the length of a signal or part of a signal at the receiving end is, therefore, a quantitative measure of the degradation of the quality of transmission and has been termed telegraph distortion. Since telegraph signals are composed of dots, dashes, and spaces, the measurement of degradation in transmission quality consists of measuring the lengths of these signal elements at the receiving end of the circuit and comparing them with their lengths at the sending end of the circuit. Means for doing this, together with a discussion of the various types of distortion affecting the lengths of telegraph signals, have been given in a recent paper.¹

As brought out in the paper referred to, distortion of telegraph signals may be divided into three components, namely, bias, characteristic distortion and fortuitous distortion. Each of these may be either positive or negative, depending upon whether the distortion causes a lengthening or a shortening of the signal part under consideration. The three components may be described briefly as follows:

Bias consists of a substantially uniform lengthening of the marks and a corresponding shortening of the spaces of telegraph signals, or vice versa. The first condition is called positive (marking) bias and the reverse condition negative (spacing) bias. It is usually due to lack of symmetry in the marking and spacing battery voltages or in the adjustment of repeating relays.

Characteristic distortion is distinguished from other types of distortion by the fact that it is a function of the signal combination as well as of the electrical and mechanical characteristics of the circuit. For example large inductance in a circuit may prevent the signaling current from building up to its full value during a short impulse following a long impulse of opposite polarity, thereby causing a decrease in the length of the short impulse which would be called negative characteristic distortion.

Fortuitous distortion is an erratic lengthening and shortening of marks and spaces such as that due to the superposition of extraneous interfering currents upon the signaling currents in the line, or due to chattering and sparking at the contacts of repeating relays.

In the case of machine telegraphy such as printing telegraph, the

¹ Nyquist, Shanck and Cory, *Trans. A. I. E. E.*, Vol. XLVI, 1927, p. 231-240.

change in length in the signal elements which will cause errors in reception can generally be determined from the construction of the machine. It has a fairly definite value for a particular type of machine and is largely independent of the type of distortion which produces it.

In the case of Morse telegraphy where the signals are received by listening to the clicks of a sounder, the effect of distortion is more complicated. Morse operators do not interpret signals entirely by the length of individual signal elements as does a telegraph printer. They interpret them by the general sound of the clicks due to the succession of dots and dashes making up a particular letter or word of the code. Consequently, it is to be expected that for the same total change in length of signal elements caused by one or more of the three types of distortion, the effect upon operators will differ, depending upon the type of distortion and upon the particular operators who are receiving. It is this phase of Morse telegraph operation with which the present paper deals.

To carry out the investigation, namely, to obtain data on the effects of various kinds and combinations of distortion on the accuracy of reception by telegraphers and their opinions as to the satisfactoriness of the received signals, several methods of procedure were suggested. These were carefully considered and the following appeared to be the most suitable.

A circuit, simulating a commercial telegraph circuit, was to be constructed and arrangements devised for impressing any desired amount of distortion or combination of distortion upon the signals transmitted over this circuit. The manner of introducing the distortions was to simulate as nearly as practicable the manner in which they would occur on real lines and the methods employed for sending and receiving the signals were to simulate closely actual operating conditions.

As regards the type of test messages to be used by the operators, it was thought that neither plain English nor unpronounceable code would be satisfactory, the former because distorted letters and words could be supplied by the operators from the context and the latter because it would be unnecessarily difficult to send and receive. Consequently, messages intermediate between these extremes were decided upon and were obtained by using text from a foreign language with which the operators were unfamiliar.

For sending the messages, a semi-automatic key (vibroplex), carefully adjusted to be unbiased and to operate at a speed of 13.5 d.p.s. (dots per second) was provided. Although this speed of operation corresponds to fairly rapid Morse sending, the rate of transmission of words during the tests was fairly low, being about 25 five-letter words

per minute. This resulted from the unintelligible nature of the text which required a wider and more careful spacing of letters and words than would have been the case with a more intelligible text.

For measuring telegraph transmission, the methods outlined in the paper referred to previously were used. A distortion measuring device which measured total distortion and the components separately, and which employed test signals known from past experience to be representative and suitable for obtaining good data on telegraph transmission, was provided. A speed of transmission of 15 d.p.s. was chosen for the test signals in order that the data obtained could be directly compared with distortions as measured in development work and in field transmission measurements. Consequently, the results of the tests could be made of immediate practical utility.

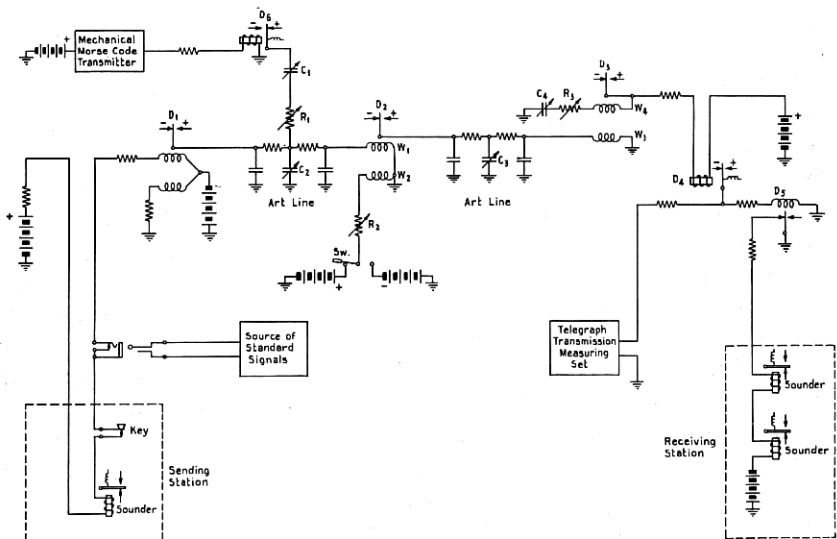

Fig. 1—Diagram of Test Circuit.

2. Test Circuit

A diagram of the test circuit is shown in Fig. 1. The telegraph circuit consisted of two artificial lines connected by a repeating relay and arranged to transmit in one direction only.

The sending operator transmitted into a local circuit at the point marked "sending station." This local circuit could also be connected to the source of standard signals which consisted of a distributor operated at a constant speed by means of a "phonic-wheel" motor.

Signals sent into the local circuit operated a sounder, a polar trans-

mitting relay D_1 and passed over the first section of artificial line to the polar receiving relay D_2 . From D_2 the signals were repeated directly into the second section of artificial line and operated the polar receiving relay D_3 . The latter relay repeated the signals into another local circuit where they were received by the neutral relay D_4 . The neutral relay repeated the signals in polar form to the transmission measuring set and also to the polar relay D_5 . The latter relay operated two neutral sounders which were located near the two receiving operators.

3. Method of Introducing Distortion

Bias was introduced into the circuit by passing a direct current through winding W_2 of relay D_2 . The direction of this current could be reversed by means of the switch SW which was arranged to connect either a positive or a negative battery to the relay winding. Consequently, either a positive or a negative bias could be introduced, the amount being controlled by means of the variable resistance R_2 . For amounts of bias greater than about 35 per cent the bias was introduced in two sections, by connecting winding W_4 of relay D_3 in series with the winding W_2 of relay D_2 . This change was found necessary to prevent failure of the system whenever large amounts of bias were desired.

Negative characteristic distortion was introduced by means of the condensers C_2 and C_3 . By increasing the value of capacity in these condensers, any desired amount of distortion up to about 70 per cent could be introduced into the circuit. The effect produced by the condensers is similar to that caused by the capacity to ground of a long cable circuit, or of intermediate composite sets and similar apparatus having condensers connected from the line wires to ground.

Positive characteristic distortion was introduced by means of transient currents in a circuit into which was connected a separate winding of one of the receiving relays. The currents flowed through the winding in such a direction as to tend to hold the relay armature against the particular contact to which the armature had been operated. The circuit consisted of the relay winding W_4 , the resistance R_3 , and the condenser C_4 , connected in series from the armature of relay D_3 to ground. By increasing the values of resistance and capacity to a sufficient extent the duration of the charging current could be made appreciably long. Consequently, a reversal of current in winding W_3 , due to the telegraph signals was not able to operate the relay armature to the opposite contact until the condenser C_4 had become sufficiently charged so that the charging current, which flowed through winding W_4 , was reduced to a value below that of the line current. The time constant of the holding circuit was such that the amount of charge on

the condenser C_4 , at the beginning of a particular signal element, was determined largely by the length of the mark or space immediately preceding this element and to some extent by the ones preceding that. As a result, this mark or space was lengthened an amount depending upon its position in the signal combination, thereby simulating the effect of positive characteristic distortion. It was necessary to introduce this type of distortion in two sections when values of distortion greater than about 35 per cent were desired. This was accomplished by connecting winding W_2 of relay D_2 in a holding circuit similar to that of winding W_4 of relay D_3 .

Fortuitous distortion was introduced by means of a telegraph crossfire arrangement. It consisted of the neutral relay D_6 whose windings were connected into a local circuit and operated by means of a mechanical Morse code transmitter. The contacts of the relay had positive and negative batteries connected to them and the armature was connected to the telegraph circuit by means of condenser C_1 and series resistance R_1 . The magnitude of the maximum fortuitous distortion was determined by the magnitude of the crossfire impulses, this being controlled by means of the condenser and resistance. Since the combination of the crossfire impulses with the telegraph signals was erratic, it is obvious that positive and negative distortions ranging from zero up to the maximum value were obtained at one time or another.

The methods described above for distorting the signals simulated closely, except possibly in the case of positive characteristic distortion, the conditions which occur on actual telegraph circuits. For this reason, the results obtained in the tests may be taken as reasonably representative of results which would be obtained on actual circuits.

4. Method of Making Operating Tests

Two series of tests were made. The first series covered all types of distortion individually and in combinations while the second series covered only those individual types of distortion the effects of which, as shown by the first series of tests, appeared questionable and for which check tests were desired.

Testing was done on alternate days between the hours of 9 a.m. and 4 p.m. Six operators were available, two for sending and the remaining four for receiving. These were divided into two groups and appeared alternately for the tests.

The method of testing was briefly as follows: the sending operator was provided with a vibroplex key and with copies of messages to be transmitted. These messages were taken chiefly from Hungarian

books and were arranged in the form of sentences and paragraphs. The words were unintelligible to the operators, which prevented them from supplying distorted parts of the messages from the context. As an additional precaution, words which occurred frequently and might have been memorized were omitted or changed arbitrarily.

At the receiving station, which was located in a different room from the sending station, the two receiving operators were provided with separate sounders and typewriters. They copied each message simultaneously and wrote their own opinions of the condition of the circuit at the end of each message. Care was taken to prevent the two operators from exchanging opinions.

On each day of the tests certain preliminary adjustments were made. The vibroplex key was first adjusted to vibrate at 13.5 d.p.s. by "beating" in a local circuit with signals from a rotary interrupter. The interrupter was then set to give signals at 15 d.p.s. and the transmission measuring set adjusted. After these adjustments had been made, standard signals from the interrupter were transmitted over the telegraph circuit and the latter adjusted for zero bias and distortion by means of the measuring set. The sending operator was then asked to send a few sentences over the circuit and the receiving operators listened to these signals and adjusted their sounders to be unbiased.

There was some question as to whether this adjustment of sounders by the operators really produced unbiased operation of the sounders. Some tests were, therefore, made in which the sounders were adjusted so that they just failed to operate properly on signals containing the same amount of large positive or negative bias. The results obtained in this case were almost identical with those obtained when the operators adjusted the sounders.

Immediately before a test message was transmitted over the circuit, distortion was introduced. Rapid measurements of distortion were made on standard signals by means of the transmission measuring set to determine when approximately the desired amount of distortion had been introduced into the circuit. An accurate measurement was then made and recorded together with the number of the test and the number of the message to be transmitted. These numbers were also recorded on the received messages and served to identify the transmission measurements corresponding to the messages received by the operators.

The various received messages were analyzed both for accuracy of reception and nature of errors produced. In determining the accuracy of reception, the number of misinterpretations in each received message was subtracted from the total number of characters in the correct

copy of the message and the difference expressed as a percentage of the latter. The nature of the errors was determined by translating the errors into the corresponding Morse symbols and comparing them with the Morse symbols for the correct characters.

5. *Transmission Measurements*

The amount of distortion present in the telegraph signals after passing over the circuit was measured by means of a telegraph transmission measuring set, as mentioned previously. This is a device for measuring any departure in the length of signal elements from their normal value. The signals used for the measurements were standard signals, obtained from a mechanical interrupter. The latter consisted of a printing telegraph distributor, operated at a constant speed and arranged to send out a particular signal during each revolution of the distributor brush arm. The procedure for the measurements consisted in connecting the source of standard signals to the sending loop of the circuit, and measuring the distortion of the various elements of this standard signal at the receiving end of the circuit by means of the measuring set.

The types of standard signals used, consisted of reversals and signals similar to the Morse letters *C* and *E*. Bias was measured with all three signals, average characteristic distortion with the *C* and *E* signals only, and maximum distortion including fortuitous with the *C* signal only.

The speed of signaling for transmission measurements was 15 d.p.s. and the values of distortion given in the following discussion refer to this speed. Since the speed of transmission by operators was 13.5 d.p.s., it is evident that the distortion which the circuit impressed upon the operators' signals was somewhat less than the values given. The distortion at the lower speed may be obtained approximately, if desired, by assuming that the per cent distortions are directly proportional to the speed of transmission.

It should also be understood that, in addition to the distortion which is due to the condition of the circuit, an appreciable amount of distortion is introduced into the signals by the sending operator. The amount of such additional distortion is a variable quantity depending on the characteristic sending of a particular operator. Neither its magnitude nor effect was determined in the present investigation which was limited to the effect which the condition of a circuit had upon the reception of signals transmitted and received by good telegraph operators.

III. DISCUSSION OF RESULTS

1. *General Effect of Distortion*

A. Effect Upon Accuracy of Reception.—The effect of distortion upon accuracy of reception, as shown by the results of the tests, differs in character for different types of distortion. In accordance with the effects produced, the various types of distortion may be divided into two general classes. The first class consists of types of distortion which produce only a small change in the accuracy of reception nearly up to the point where the circuit actually fails. The second class consists of types of distortion which produce a rapid decrease in accuracy of reception when the distortion is increased beyond a certain moderate value. Of the various types of distortion encountered on telegraph circuits, negative bias and fortuitous distortion fall into the first class while positive bias and positive and negative characteristic distortion fall into the second class.

Combinations of various types of distortion in which one type of distortion predominates appear generally to fall into the same class as the predominating type of distortion in the combination. There is, however, a marked tendency for many combinations of distortion to fall into the first class, especially, when the various distortions in a combination are about equal in magnitude.

The accuracy of reception for a particular circuit condition differed considerably with operators. For the case of zero distortion in a circuit, most of the operators consistently reached accuracies between 98 and 100 per cent while other operators failed to reach accuracies higher than 88 per cent. This difference is due partly to the fact that some of the receiving operators were more experienced than others and partly to poor sending by some of the sending operators. It is of interest, however, that the general shape of the distortion versus accuracy curve for a given condition is unaffected by this difference.

B. Effect Upon Opinion of Operators.—In general, the various operators were in fair agreement as to the point at which a circuit became unsatisfactory for commercial operation. This point corresponded closely with the decrease in accuracy of reception for some types of distortion but differed widely from it for other types of distortion. In those cases for which the opinion of operators disagreed with their accuracy of reception, the operators usually pronounced the circuit unsatisfactory at values of distortion considerably lower than those required to cause an appreciable decrease in their accuracy of reception. The reason given for condemning such a circuit at the low value of distortion was the peculiar sound of the signals. This, they

claimed, required an unusual amount of concentration on their part, causing fatigue and making it difficult to receive over the circuit for a long period of time.

The type of distortion for which the disagreement between opinion and accuracy of reception was most pronounced, is negative characteristic distortion. The operators considered 25 per cent of this type of distortion to be about the maximum allowable value for commercial operation, whereas about 50 per cent was required to cause an appreciable reduction in their accuracy of reception. These values were checked a number of times with different operators and appear to be well established. A similar condition occurred in the case of fortuitous distortion for which the corresponding values are 50 per cent and 85 per cent, respectively. In this case, however, the infrequent occurrence (about four times a minute) of the maximum value of this type of distortion probably accounts for the small effect on the accuracy of reception.

These results would seem to indicate that the accuracy of reception is not a complete criterion of the allowable amount of distortion in a telegraph circuit. It is undoubtedly true that operators who work over a circuit, often do not wait until they make errors before calling the repeater attendant to fix the circuit. They usually take such steps as soon as they notice any appreciable distortion or have any difficulty in receiving signals.

In explanation of this point it may be said that when an operator is receiving perfect signals at a speed below the maximum rate at which he can work, he has what may be termed a "margin of attention" which may be utilized in interpreting defective signals. Before the point is reached where his accuracy of reception is impaired, he experiences a reduction in the "margin of attention" and on that account may pronounce a circuit unsatisfactory, since operation with little or no "margin of attention" soon produces a mental strain. The reception of signals having frequent distortions of say 30 per cent may very likely decrease the "margin of attention" to a greater extent than the reception of signals having only occasional distortions of 60 per cent or even greater. Also, if the speed of transmission during the tests had been slower or faster, the "margin of attention" would have been greater or less, and the point at which the operators considered the circuit unsatisfactory would have been different.

Because of the above it is thought that in establishing allowable limits of distortion for commercial telegraph circuits, the opinion of operators must be given consideration in addition to the accuracy of reception.

2. *Effect of Bias*

A. *Positive Bias.*—The relationship between the amount of positive bias and the accuracy of reception by operators is given in Fig. 2, in which is plotted the average of the results obtained in three tests.

It will be seen from an inspection of this curve that the accuracy falls off rapidly between 40 per cent and 50 per cent bias in which region the majority of the operators also called the circuit unsatis-

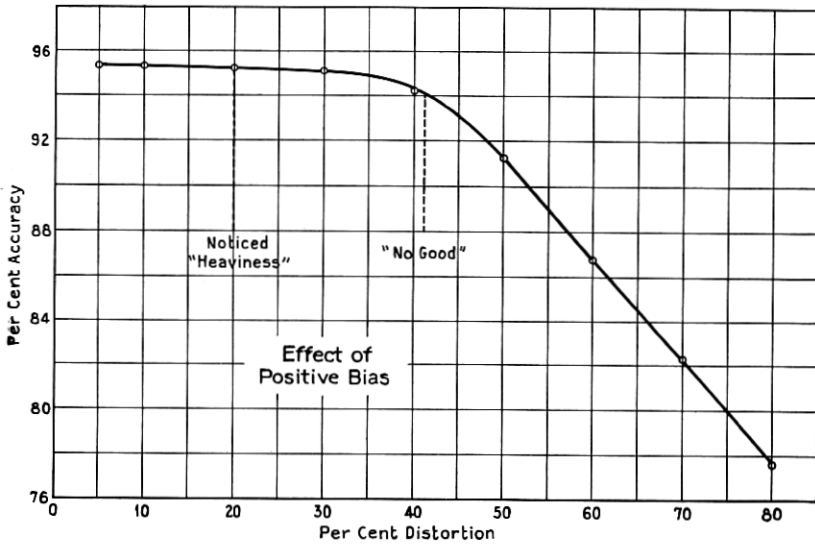

Fig. 2.

factory. The three most interesting facts, as depicted on this curve, are as follows: The accuracy of reception changed very little up to a bias of about 40 per cent but decreased rapidly above this value. The operators remarked upon the bias when it reached a value of about 20 per cent, and considered the circuit unsatisfactory with a bias of about 40 per cent.

An analysis of the errors made by the operators for values of bias from 35 per cent to 70 per cent showed that most of the errors were due to the omission of letters. This indicates that the effect of positive bias was such as to confuse the operators and cause them to miss characters while trying to interpret some peculiar sounding character which had gone before. There was very little indication of errors due to interpretations of dots as dashes even for a bias greater than 50 per cent. Most of the interpretations were of a miscellaneous nature, although there were a few errors which appeared to be due to a dropping out of spaces between signal elements.

B. Negative Bias.—The curve of Fig. 3 shows the effect of negative bias. As in the case of positive bias above, this curve is also an average of three test curves.

With this type of distortion the accuracy of reception is influenced only slightly with increase in distortion over wide limits. There is a gradual decrease in accuracy of reception up to about 65 per cent distortion and a more rapid decrease beyond this value.

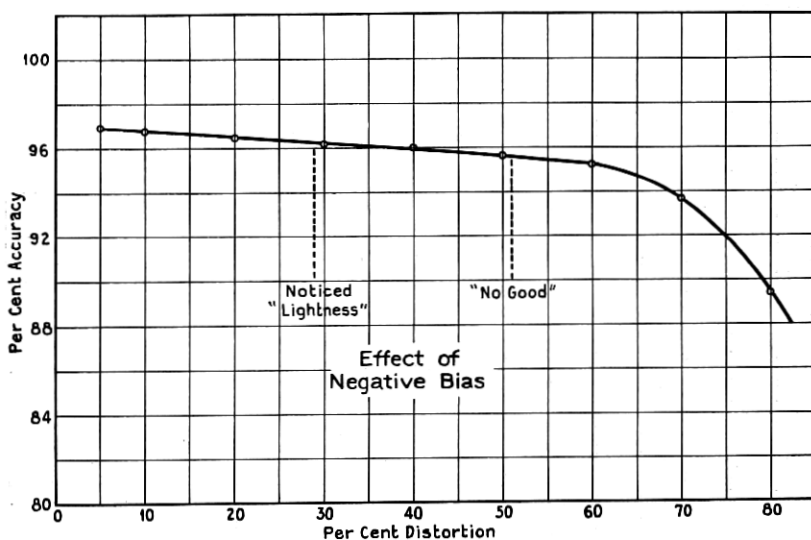

Fig. 3.

It was thought that possibly the difference in the effect of positive and negative bias was due to the adjustment of the sounders. If the operators had adjusted the sounders to be biased slightly heavy for the condition of zero bias over the circuit, then the sounders would have failed sooner on a circuit with positive bias than on one with an equal amount of negative bias. Some tests were, therefore, made for which the sounders were adjusted so as to fail to operate properly for equal values of large positive and negative bias in the circuit but the results obtained were the same. It may be concluded, therefore, that the effect is mainly of a psychological nature and is not due to a difference in the adjustment of the apparatus.

The noteworthy features in the results of tests with negative bias are as follows: The accuracy of reception decreased gradually with increase of distortion up to about 65 per cent, and fairly rapidly above this value. The operators remarked upon the bias when it reached a

value of about 30 per cent and considered the circuit unsatisfactory at about 50 per cent.

An analysis of the errors made by the operators for values of distortion from 30 per cent to 70 per cent indicated that a large number of errors were due to confusion, as in the case of positive bias. For large values of bias there were some errors which indicated an interpretation of dashes as dots, although most of the errors were miscellaneous interpretations, together with a large number of letters added and omitted.

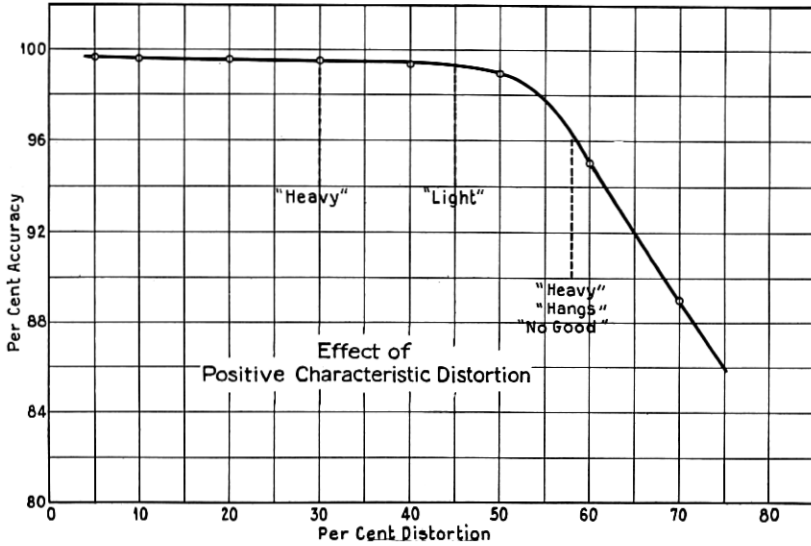

Fig. 4.

3. Effect of Characteristic Distortion

During the tests with positive and negative characteristic distortion, a peculiar effect of moderate amounts of such distortion on the opinion of operators was noticed. In general, operators tend to call a circuit "heavy," "light," or "unsteady." If the amount of characteristic distortion is not large enough to warrant the term "unsteady," some operators may call the circuit "light" while others may call it "heavy." In a few cases the operators stated that the bias changed constantly from one letter or word to another. The latter characterization is probably the more accurate and accounts to some extent for the difference of opinion. When the amount of distortion becomes large enough so that the operators consider a circuit "unsteady," they also call it "light" in most cases.

A. Positive Characteristic Distortion.—The curve of Fig. 4 shows the effect of positive characteristic distortion as determined by averaging the results of two test curves and a number of qualitative check tests. The effects of this type of distortion upon reception are briefly as follows: The accuracy of reception remained practically constant up to a distortion of about 50 per cent and decreased rapidly above this value. The operators remarked upon the distortion at a value of about 30 per cent and considered the circuit unsatisfactory at about 50 per cent.

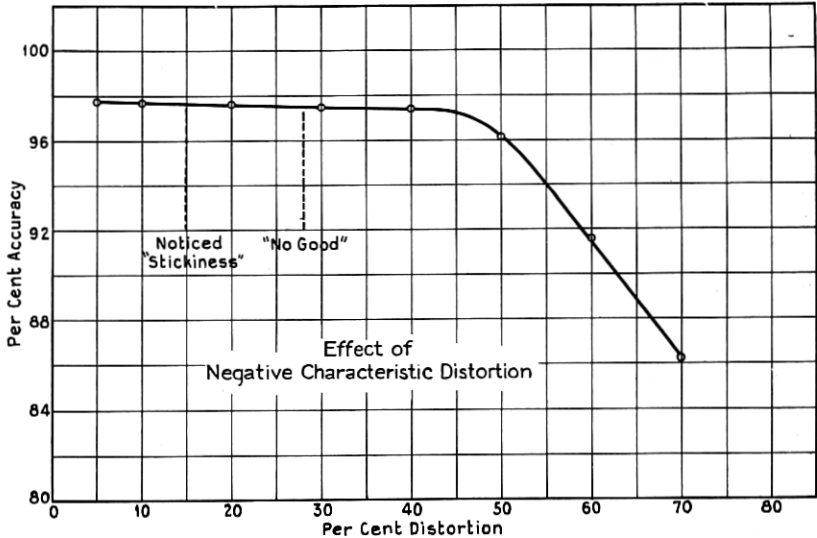

Fig. 5.

The errors produced by positive characteristic distortion were analyzed for values of distortion from 35 per cent to 65 per cent. The results obtained indicated that most of the errors for distortions greater than 50 per cent were due to a lengthening of dots at the beginning of letters and a dropping out of dots at the middle and at the end of letters. As a consequence a large number of errors were due to the following misinterpretations: H interpreted as B; S as G; N as T; J as K; C, A, J or F as M. In addition an appreciable number of errors were due to miscellaneous interpretations together with a large portion of letters added and omitted.

B. Negative Characteristic Distortion.—The effect of negative characteristic distortion is illustrated by the curve of Fig. 5 which is an average of three test curves and several qualitative check tests. This type of distortion is of considerable interest due to the fact that a

value of distortion lower than that with any other type or combination of distortion causes a circuit to be unsatisfactory, according to the opinion of the operators. Moreover, the opinion of the operators disagrees considerably with the effect which the distortion has upon their accuracy of reception, as shown by the curve.

A summary of the effect of negative characteristic distortion as given on the curve of Fig. 5 is as follows. The accuracy of reception remained nearly constant up to about 45 per cent distortion and then commenced to decrease rapidly. The operators remarked on the distortion at about 15 per cent and considered the circuit unsatisfactory at about 30 per cent.

The nature of the errors made by operators for this type of distortion was analyzed for values of distortion from 15 per cent to 70 per cent. Consistent misinterpretations occurred for distortions greater than 40 per cent and were similar to those obtained with positive characteristic distortion. The most common errors were as follows: J interpreted as K or M; N as T; G as M; and K as M. In addition, there were the usual miscellaneous interpretations, together with a large number of letters added and a smaller number of letters omitted.

4. *Effect of Fortuitous Distortion*

The curve of Fig. 6 which is an average of three test curves, illustrates the effect of fortuitous distortion upon the accuracy of reception. The distortions plotted are the maximum values which were equalled or exceeded about three or four times a minute. It appears from the curve that large amounts of fortuitous distortion have very little effect upon the accuracy of reception. In fact the accuracy is practically unchanged over the range of distortion from zero to 75 per cent. This is not very surprising in view of the fact that such distortions occur only about three or four times per minute, and may affect signals without destroying their identity. Even with fortuitous effects of such large values as to cause the breaking up of signals, only a relatively small decrease in the accuracy of reception was produced in certain tests.

The errors made by the operators for this type of distortion were largely of a miscellaneous nature. There were very few misinterpretations which were repeated consistently, although most of the errors indicated a shortening of dashes to dots and a dropping out of dots and spaces. There were also a considerable number of letters omitted and a few letters added.

Briefly summarized, the effects of fortuitous distortion upon reception are as follows. The accuracy of reception remained practically

unchanged up to a distortion of about 75 per cent and decreased slowly for distortions above this value. The operators first remarked upon the distortion at a value of about 35 per cent and considered the circuit unsatisfactory at about 50 per cent.

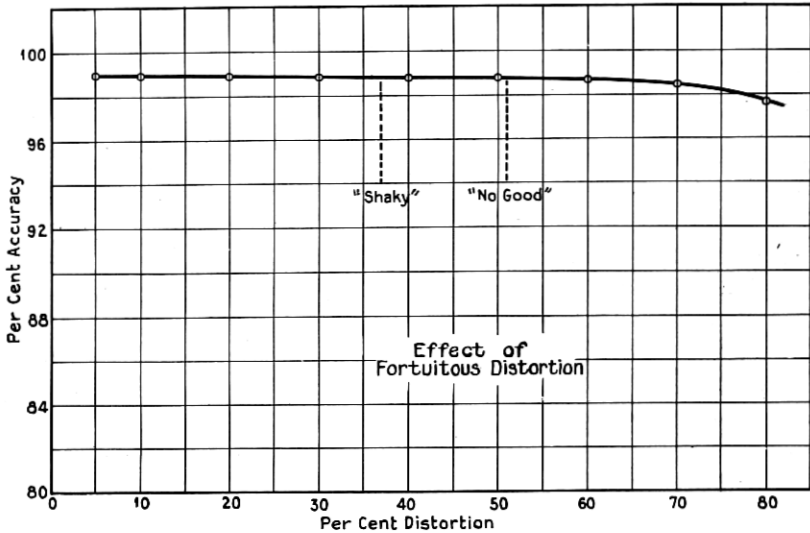

Fig. 6.

5. Effect of Combined Distortions

A large number of tests were made with various combinations of distortions, the results of which were also plotted in the form of curves. These curves are not included here because of lack of space but the results obtained are discussed below.

The maximum permissible distortion is generally much higher when the distortion occurs in combinations of various kinds than when it occurs singly. This is true when judged either from the standpoint of accuracy of reception or opinion of operators. Moreover, it appears that the shape of the distortion versus accuracy curve is determined largely by the predominating type of distortion.

It would seem from the above that a measurement of maximum distortion only, is not sufficient to determine the condition of a telegraph circuit. For example, a circuit may have a maximum distortion of about 50 per cent. If this is made up of 35 per cent negative characteristic distortion and 15 per cent fortuitous distortion the circuit would be considered very poor by the operators. If, however, it were made up of 15 per cent negative characteristic distortion and 35 per cent fortuitous distortion, the circuit would be considered fairly good. Similar deductions can be drawn from other combinations of distortion.

There was also some indication that a circuit which contains an appreciable amount of one type of distortion may be improved by adding a certain amount of some other type of distortion, even though the total distortion is increased thereby. This was brought out in a certain test where 25 per cent negative characteristic distortion by itself made the circuit unsatisfactory. By adding 15 or 20 per cent positive bias the quality of the signals was improved, as shown by the accuracy of reception and by the opinion of the operators, even though the maximum distortion was increased from 25 per cent to 40 or 45 per cent.

The nature of the errors made by operators for combined distortions in the circuit varied greatly for different combinations of distortion. Positive bias combined with moderate amounts of negative characteristic distortion gave errors similar to those for negative characteristic distortion alone. On the other hand negative bias combined with moderate amounts of negative characteristic distortion gave errors of a miscellaneous nature, such as were obtained with negative bias alone. Combinations of fortuitous distortion with moderate amounts of positive bias gave errors which indicated a consistent lengthening of marks and dropping out of spaces, as for example, interpretations of A as M; N as T and J as K. Combinations of fortuitous distortion with negative bias, however, gave errors which were chiefly of a miscellaneous nature. In addition to the above there was an appreciable number of letters added and omitted for all combinations of distortion.

A brief summary of the effects of combined distortion upon reception is as follows. The curves of accuracy versus distortion have the same general shape as the curves for the predominating type of distortion taken by itself, and the maximum permissible distortion, as judged either by the accuracy of reception, or by the opinion of the operators, is generally higher than for the various combined distortions taken by themselves. The values of total distortion at which the accuracy of reception began to decrease, ranged from about 55 to 100 per cent. The operators considered the circuits unsatisfactory at values of distortion ranging from about 50 to 65 per cent.

IV. SUMMARY

There are given below conclusions which have been drawn tentatively from the results of the present tests. Further tests are desirable in order to confirm the results obtained thus far. For the present, however, it is thought that the ideas as to the effect of distortion upon

manual Morse operation outlined below, can be of material use as a general guide.

1. The effect of distortion upon accuracy of reception differs in character for different types of distortion. For some types of distortion the accuracy decreases rapidly when the distortion exceeds a certain value, which indicates that there is a rather definite limiting value of distortion. For other types of distortion, the accuracy of reception decreases very little nearly up to the point where the circuit actually fails.

2. The amount of distortion which appears to be tolerable, both from the standpoint of accuracy of reception and from the opinion of operators appears to be larger for combined distortions than for the individual types of distortion. This would seem to indicate that the maximum distortion by itself, without at least a general idea as to the components making up the distortion, is not sufficient to indicate how satisfactory the circuit will be for handling manual telegraph service.

3. The effect of distortion upon the operators themselves, as indicated by the errors which they made, appears to be such as to cause hesitation and a resulting confusion while interpreting distorted signal combinations. Most of the errors in the case of large distortions consisted of miscellaneous interpretations with letters frequently added or omitted. For some types of distortion, especially those for which the accuracy of reception begins to decrease rapidly at a certain value of distortion, consistent misinterpretations were made. These usually occurred after the accuracy of reception had decreased appreciably, and were of a nature such as would be expected from the type of distortion present in the signals.

4. The opinion of the operators as to the amount of distortion above which a circuit is unsatisfactory for commercial operation, is in reasonable agreement with the effect on their accuracy of reception for some types of distortion; for other types of distortion there is considerable disagreement. In general, the operators pronounce a circuit unsatisfactory before the point is reached where the accuracy of reception decreases appreciably.

The agreement which exists between the two criteria is shown in the following table. The values in the first column of the table are based on the opinion of the operators, while those in the second column are based on their accuracy of reception and are those values at which the accuracy has decreased 2 per cent from the initial value. In every case the value given is the average for all the tests made with a particular type of distortion.

Kind of Distortion	Limiting Values	
	From Opinion of Operators	From Curves of Accuracy of Reception
1. Positive bias	40%	45%
2. Negative bias	50%	65%
3. Positive characteristic distortion . . .	58%	55%
4. Negative characteristic distortion . . .	28%	53%
5. Fortuitous distortion	51%	85%
6. Various combinations of distortion . .	50 to 65%	55 to 100%

5. Judged from the *opinion of operators*, all types and combinations of distortion with the exception of negative characteristic distortion and positive bias become objectionable at values of about 50 per cent. Negative characteristic distortion appears to become objectionable at about 30 per cent and positive bias at about 40 per cent. On the other hand, judged from the *accuracy of reception* of the operators, all distortions, with the possible exception of positive bias, become objectionable only at values above about 50 per cent. In the case of combined distortions there is considerable disagreement when large amounts of fortuitous distortion are present. The reason for this is discussed under Section III "Discussion of Results—4. Effect of Fortuitous Distortion."

The disagreement between opinion and actual performance is of considerable interest, since it shows that operators will condemn a circuit due to the presence of distortion even though their accuracy of reception is not materially influenced thereby. It is probable, therefore, that in establishing allowable limits of distortion for commercial telegraph circuits, both the accuracy of reception and the opinion of operators will have to be considered.