

Machine Switching Telephone System for Large Metropolitan Areas

By E. B. CRAFT, L. F. MOREHOUSE and H. P. CHARLESWORTH

SYNOPSIS: From the earliest forms of telephone switchboards to the modern types, the development of the switchboard has been marked by the increasing use of automatic methods to supplement the manual operation wherever this would result in better service to the public or more efficient operation.

In addition to all that has been done in developing and introducing automatic operations with manual switchboards, it has been found desirable and practicable to go further in the direction of introducing automatic operation in the telephone plant and a machine switching system has been developed in which the bulk of the connections are established without the aid of an operator.

The complexity of a large metropolitan area and the exacting requirements which a machine switching system must meet are outlined briefly, and the system which has been developed to meet these requirements is described.

The application of the system to a typical large metropolitan area and the means provided for permitting its gradual introduction into the existing plant are discussed.

IT is the purpose of this paper to outline briefly certain important developments in connection with machine switching telephone systems and to discuss the application of the results of these developments to the problem of providing telephone service in large metropolitan areas.

The telephone was invented in 1876. Almost immediately thereafter it was recognized that, for it to attain its greatest field of usefulness, switchboards and switching centers would have to be established for effecting interconnection between subscriber's lines.

Professor Bell's vision of the future was given in a statement to prospective investors. He said:

"It is conceivable that cables of telephone wires could be laid underground, or suspended overhead, communicating by branch wires with private dwellings, country houses, shops, manufactories, etc., etc.—uniting them through the main cable with a central office where the wires could be connected as desired, establishing direct communication between any two places in the city. Such a plan as this, though impracticable at the present moment, will, I firmly believe, be the outcome of the introduction of the telephone to the public. Not only so, but I believe in the future wires will unite the head offices in different cities, and a

Presented at the Midwinter Convention of the A. I. E. E., New York, N. Y., February 14-17, 1923. Published in the Journal of A. I. E. E. April, 1923.

man in one part of the country may communicate by word of mouth with another in a distant part.

"Believing, as I do, that such a scheme will be the ultimate result of the telephone to the public, I will impress upon you all the advisability of keeping this end in view, that all present arrangements of the telephone may be eventually realized in this grand system."

EARLY DEVELOPMENTS

The only apparatus available at that time for this purpose was that employed in telegraph, messenger, fire and burglar alarm services. Some of this apparatus, such as wire, insulators, batteries, annunciators, etc., was found to be useful in the new art; other apparatus had

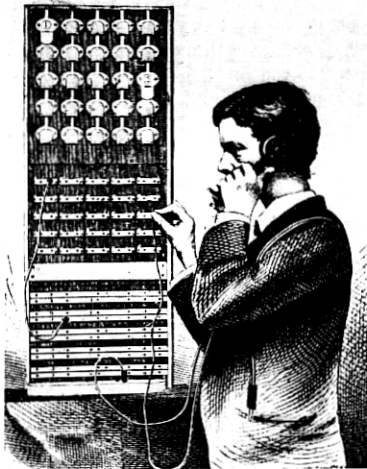

Fig. 1—Early Type Switchboard

to be developed. The switchboards of that day employed this apparatus. They were small in size, and could accommodate only a limited number of lines.

It soon became evident that the requirements of the telephone exchange service demanded signaling and switching equipment different from that employed in any of the other branches of the electrical industry, and it became necessary to create an entirely new art, involving many branches of science, before commercial telephone service could be given on an adequate scale. The switchboards grew from small boards, capable of handling a few lines, as

shown in Fig. 1, to the very complex arrangements providing signaling, switching, and transmission facilities for as many as ten thousand lines in a single board, of the type shown in Fig. 2.

As the subscribers increased in number it was found that beyond a certain point it was no longer practicable or economical to have all of the subscribers' lines brought to one center. It was therefore, necessary to have several centers, the number depending upon many factors, the most important of which are the size and telephone needs of the community.



Fig. 2—Modern Type Common Battery Switchboard

The consequence of all this is that in large metropolitan areas the number of centers is large, and the trunking system complex, as each center must be provided either directly or indirectly with trunks to every other center.

As an illustration, take the New York Metropolitan area, shown in Fig. 3, where the telephone plant is of the greatest intricacy because of the very large number of subscribers served. There are at the present time 158 central office switchboards, many of them having

equipment for 10,000 lines. These offices and the associated plant provide for intercommunication between 1,400,000 telephones, and approximately two trillion possible connections. It is estimated that by the year 1940 there will be 300 central office switchboards within the New York Metropolitan area, serving some 3,300,000 telephones—or nearly two and a half times the present number.



Fig. 3—Map Showing Location of Central Offices in New York Metropolitan Area

MANUAL SWITCHBOARDS

The system most commonly employed today for connecting subscribers' lines together is the so-called "manual" system; that is, a system in which operators are employed to make the actual connections between subscribers' lines, although so many of the functions are performed automatically that, except in name, it is to a large degree automatic.

It is a long step from the early switchboards to the modern common battery multiple manual switchboards. The history of the development of switchboard equipment and apparatus shows that enormous progress has been made in this art in a comparatively few years. As the telephone subscribers have grown in number and as the amount and complexity of the traffic have increased, it has been only by the most intensive development that it has been possible to keep ahead of the demand for telephone service, and that telephone engineers have been able to get the speed, efficiency and accuracy that are obtained

today in so-called manual operation. It is worthy of note in this connection that the attainment of these ends was made possible by the extensive introduction of automatic features.

A very brief description at this point of the type of manual switchboard more commonly employed will be helpful.

In this switchboard the subscriber's line terminates at the central office in so-called "jacks." Associated with each line is a lamp, individual to it, which automatically lights when the subscriber removes his receiver from the hook. This serves as a signal to the operator that a connection is desired.

The operator answers this call by inserting one end of a cord in the jack associated with the calling subscriber's line, operates a listening key which connects her telephone set to the subscriber's line, and asks for the number desired. When this is obtained the operator completes the connection by inserting the other end of the cord in the jack of the desired subscriber's line, and the subscriber's bell is rung. Suitable lamp signals are provided so that the operator may know when the called subscriber answers, when either subscriber desires further attention, or when either or both of them have finished talking and have hung up their receivers.

If the subscriber desired is connected to a distant office, the operator receiving the call would, instead of plugging directly into the subscriber's line, directly connect the subscriber's line to a trunk terminating in the desired office, where the connection would be completed by a second operator, known as the "B" operator, as shown in Fig. 4.

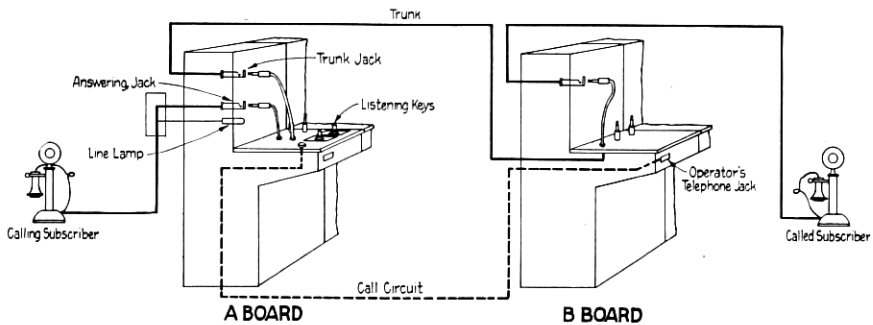

Fig. 4—Diagram Showing Manual Interoffice Connection

Such communication between the two operators as is necessary to establish this connection takes place over a special pair of wires known as a "call circuit."

The method, of which the above is a bare outline, is that used in completing ordinary connections. Different arrangements and different operating methods have to be provided for handling short haul toll calls, long distance calls, calls from coin boxes, and calls of many other kinds.

In the simplest types of manual systems, the subscriber, in order to signal the central office, turns a crank thus operating a magneto generator. This throws a drop in front of an operator at the central office. In the switchboards developed to meet the needs of the larger areas, electric lamps are substituted for the drop, and relays automatically controlled by the subscriber bring them into play at the proper time. Electric lamps which serve as visual signals to the operator to indicate the status of the connection are also associated with the cords that the operator uses for connecting subscribers together. The operation of these lamps is automatic and is under the control of the switchhook at the subscriber's station.

Many other arrangements of an automatic character have been developed and are used as occasion requires—not merely because they are automatic in character but only when it has been established that they make for better service to the public or for efficiency and economy of operation, or both. Among these may be mentioned automatic ringing, automatic listening, and many forms of automatic signaling. Many of these arrangements are highly ingenious and contribute greatly to the efficiency and economy of operation. Thus, the trend of switchboard development has been more and more in the direction of automatic operation and automatic methods.

In addition to all that has been done in developing and introducing automatic operation with so-called manual switchboards, it has been felt for a long time that in large and complex telephone areas, such for example as New York City, the time would ultimately come when it would be desirable to go further in the direction of introducing automatic operation in the telephone system. This whole matter has been the subject of much thought on the part of engineers of the Bell System and, as a result, there has been developed and recently put into operation a system in which the work of establishing most of the local connections is done entirely by machinery.

The introduction of this system will eventually make a considerable reduction in the telephone company's requirements for operators which are becoming more difficult to fulfill year by year. Operators will be required, however, to handle toll and many special classes of local calls and for this reason, together with the constant growth of the business and the considerable period of time that will be re-

quired to introduce the new system completely, we can expect little or no reduction in the present operating forces for some time to come, and no operator will find herself out of employment on account of the introduction of the machine switching system.

MACHINE SWITCHING

It is the purpose of this paper to describe this system sufficiently in detail to give a general picture of it, but because of the limitation as to space no attempt will be made to go into the intricacies of circuits and apparatus, which doubtless would be of interest only to the telephone engineering specialists.

Among other requirements, the following must receive special consideration in the design of a machine switching system.

The functions to be performed by the telephone subscriber in getting a connection must be simple and easily understood.

It must work efficiently and with accuracy and speed, and, of course, must be capable of handling the various types of calls that the subscriber wishes to make.

The system must not require modifications in the existing rate structure, otherwise than desirable. If the rate structure calls for message register operation, coin boxes, etc., means must be provided for automatically operating the register and collecting the coins on such calls, and for preventing a charge on calls not answered, calls for free lines, busy lines, etc.

The system should employ, as nearly as practicable, the conventional numbering scheme.

It should work with the existing telephone network, so that its introduction does not require wholesale number changes and extensive rearrangement or the abandonment of existing switchboards or other plant. Its introduction must, of necessity, be on a gradual basis.

It must be sufficiently flexible in design to care for growth and such changing traffic conditions as occur from time to time.

In large telephone areas, such as the New York Metropolitan area, there is a great variety of calls to be handled and many different classes of service furnished the public, such as message rate, flat rate, official, coin box, non-attended pay station, attended pay station, special services such as information, etc. Not only individual lines but party lines, and private branch exchanges must be cared for, and provision must be made for thousands of toll messages which must be recorded, supervised and timed.

A call originating in a machine switching office in New York City may have as its destination any one of a great number of points. It

may be for another subscriber in the same office or for one in another nearby machine switching or manual office; it may be for one of a large number of suburban toll points, or it may be to some point in a distant city.

The machine switching system, which is the subject of this paper, meets these requirements. After long-continued laboratory experi-



Fig. 5—Desk Stand Equipped with Dial

ments, supplemented by field trials, power-driven apparatus of the panel type has been found to be the most suitable, and is now in successful operation in New York City and in other large cities in the country.

GENERAL PLAN OF OPERATION

At the expense of some repetition it seems desirable in order to give as clear an understanding as possible as to the operation of the system, to first give a brief outline of how the call is handled and a description of the more important elements of the equipment, before going into a detailed description of the operation of the system.

The subscriber's station is equipped with the usual form of telephone instrument and, in addition, with a calling device known as a "dial," mounted at the base of the desk stand, as shown in Fig. 5. This dial has ten finger holes, bearing letters and figures, as shown in Fig. 6.

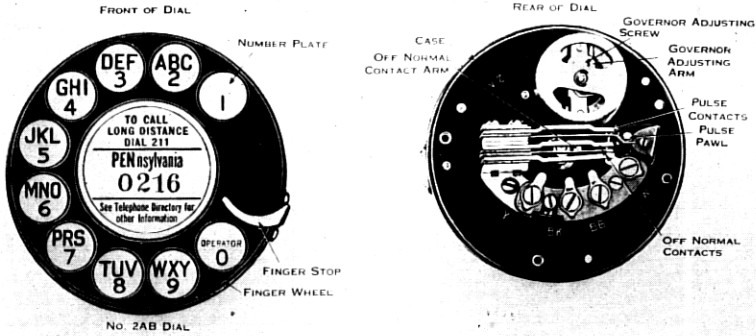

Fig. 6—Subscriber's Dial

In making a call the subscriber will, of course, first refer to the telephone directory. He will find in the directory a listing that is only slightly different from that to which he is accustomed. Typical samples of this new form of telephone listing for New York City are shown in Fig. 7. As will be noted, these conform to the present

Argent Co, 1400 Bway.....	GRE	eley	5513
Argentina Brazil & Chile Shipping Co			
70 Wall.	HAN	over	0307
Argentine Genl Consulate, 17 Batry pl.	REC	tor	6946
Argentine Impt & Expt Corp, Prod Ex.	BRO	ad	1768
Argentine Mercantile Corp, 42 Bway.....	BRO	ad	5066
Argentine Naval Commission, 2 W 67.	COL	mbus	5623
Argentine Quebracho Co, 80 Maiden la....	JOH	n	1652
Argentine Railway Co, 25 Broad.....	BRO	ad	1383
Argentine Trading Co, 1164 Bway.....	MAD	Sq	1871
Argeres Bros, Restrnt, 86 6th av.....	SPR	ing	5337
Argero A. Grocer, 119 9th av.....	CHE	lsea	6255
Arghis A, Tobacco, 74 Wall.....	HAN	over	6311
Argirople Theodore, Jwlr, 406 8th av.	FAR	ragut	9772
Argo Packing Corpn, 705 Greenwich...	FAR	ragut	4505
Argon Dress Co, 24 E 12.....	STU	ysnt	2011
Argonaut Supply Corp, 50 Union sq.	STU	ysnt	7476
Argonne Steamship Co, 17 Battery pl.	REC	tor	2493
Argos Ad-Art Co, 1133 Bway.....	FAR	ragut	5986
Argosy The (A Pub), 280 Bway.....	WOR	th	8800

Fig. 7—Typical Examples of New Form of Listing Telephone Numbers

manual listings, except that the first three letters of the office name are set out prominently. This numbering system will be discussed later in this paper.

Having secured the desired telephone number from the directory, which we will assume is "ACAdemy 1234," the subscriber will first remove his receiver from the hook and will hear the so-called "dial tone," which indicates that the apparatus is ready to receive the call. He will then insert his finger in the hole over the letter *A*, rotate the dial until the finger comes in contact with the metal stop shown in the picture, then release the dial, which will automatically return to normal. He will repeat this operation for the letters *C* and *A*, and in turn for the four numerals, *1*, *2*, *3*, *4*.

This operation of dialing on the part of the subscriber is exactly the same, whether the telephone number he desires is in a manual or a machine switching office. Similarly, the method employed by a subscriber who is connected to a manual office in getting a subscriber connected to a machine switching office, is the same as though the desired subscriber were connected to another manual office.

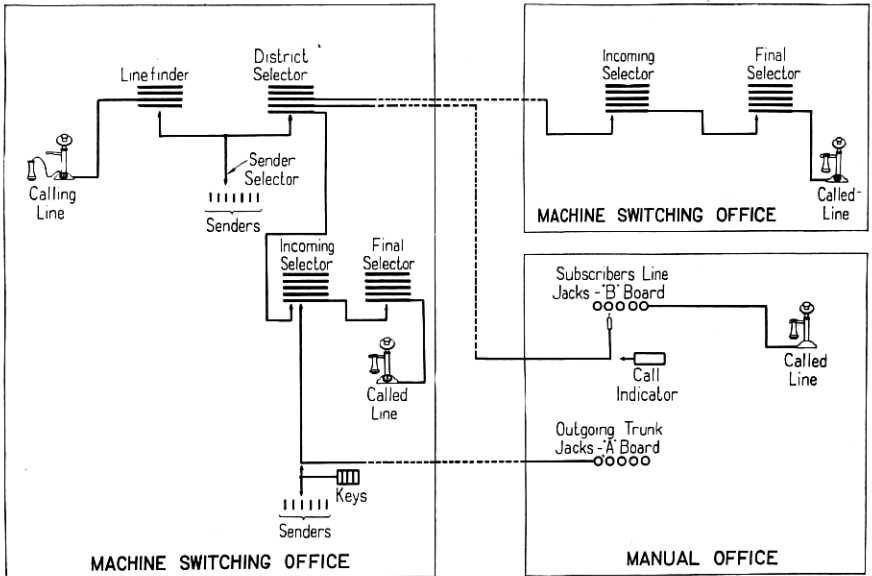

Fig. 8—Diagram Showing Connections from Machine Switching to Machine Switching, Machine Switching to Manual and Manual to Manual Switching

The progress of a call originating in a machine switching office is briefly as follows:

As will be seen from Fig. 8, the line of the calling subscriber, whom we will assume to be a subscriber in the Academy office, appears in a so-called "line finder" frame. When the subscriber's receiver is

removed from the switchhook preparatory to dialing, the line is selected by a "line finder" and connected to an idle "sender" by means of a "sender-selector."

Upon completion of these operations which take but a fraction of a second, the dial tone is sent to the calling subscriber as previously mentioned. When the subscriber dials, electrical impulses on a decimal basis are transmitted to the sender which receives and registers them, translating them in turn to the proper basis for the control of the selectors which are not operated on a decimal basis. The sender automatically causes the particular "district selector" which is permanently associated with the line finder originally used, to select a trunk to the office desired.

Assuming that the call is for a subscriber in the same office, Academy, the trunk chosen will terminate at an "incoming selector" frame and the sender above referred to will cause the call to be routed through the incoming selector to a final selector, and thence to the particular line desired. When the connection is thus completed, audible signals will be sent back to the calling subscriber to indicate that the station is being rung or that the line is busy.

If the call had been for a subscriber in another machine switching office, namely, Pennsylvania, the call would be routed from the district selector to the office desired, either directly or through an "office selector" in case the total number of trunks to all offices is too large to be placed on the district selector multiple. These trunks terminate on incoming selectors at the Pennsylvania office which select the subscriber's line through final selectors, as described above.

If the call is for a subscriber connected to, say, the Worth Office, which is a manual office, the call would be routed from a district selector directly or through an office selector to the "B" board in the Worth Office, where the number desired appears in front of the operator at a "call indicator position" in the form of visible numbers on the keyshelf. The operator is advised of the trunk to which the call is connected by suitable signals, and the call is completed by plugging this trunk into the desired subscriber's line.

Calls originating in a manual office and intended for a machine switching office reach the machine switching office over trunks from the "A" operators in the manual office. At the machine switching end these trunks terminate in incoming selectors, which have access to the final selectors on which the subscriber's lines are located. The selectors are under the control of a special group of senders, and operators are provided with suitable keys for setting up in these senders the number of the desired subscriber. These operators at

the machine switching office receive the information as to the desired number from "A" operators in the distant manual office, exactly as is done in the case of manual operation.

The introduction of machine switching equipment does not require radical changes in private branch exchanges. The private branch exchange is provided with dials, and calls to the central office are dialed by the private branch exchange attendant or by the extension user in the same way that the ordinary subscriber dials. No change in the private branch exchange is required for handling incoming calls. An idle trunk in the private branch exchange group is selected by the mechanism in the machine switching office, in much the same way as an individual subscriber's line is selected.

NUMBERING SYSTEM

One of the unique advantages of the plan developed for designating telephone numbers, to which reference has already been made, is that it does not necessitate the abandonment of the existing manual listings. It requires no change except that the first three letters of the office name are set out more prominently. Simple as this change in the form of listing appears, until it was developed by the Bell System no satisfactory method of designating telephone numbers for machine switching offices in large cities was known.

Many plans had been proposed, to all of which there were serious objections. Some of them required changing the whole system of manual designation, others the use of combinations difficult for the subscriber to use. In small cities a numbering plan employing only digits is sometimes practicable, but in such a large area as we are considering, such a plan would involve seven digits. The subscriber's number would take the form of say 786-3549. Such numbers would be difficult for operators to use and for the subscribers to carry in mind and would require that every subscriber's number in the entire area be changed before the first machine switching office could be cut into service. With the new system, the subscriber's number and office in general remains as before. It is necessary to change only a few conflicting office names in order to make them fit into the system.

DESCRIPTION OF THE EQUIPMENT

A detailed description of each unit employed in this system would be impracticable, in this connection, but a brief description of the more important ones will be of interest.

Sender. The use of the sender makes practicable the introduction of machine switching in large metropolitan areas where, of necessity,

the service conditions are extremely complex. It is, in effect, the brains of the system, dealing with the subscriber and controlling the selection until the destination is reached, as an operator deals with the subscriber and controls the selection in a manual system. The number dialed conveys the same information to the sender in a machine switching system as the number spoken by the subscriber does to an operator in a manual system.

The sender is an arrangement of relays, sequence switches, and selectors, so worked out as to perform the following more important functions:

1. It receives a succession of electrical impulses from the subscriber's dial which are on a decimal basis, stores them and translates them to a non-decimal basis, corresponding to the particular group of lines and trunks that is involved in the path of the call.

2. It controls selecting mechanisms which build up the connection to the called party in such a manner that each mechanism is given the exact time required to perform its functions without any waste of time, independently of the rate received from the dial.

3. It makes the central office designations entirely independent of the arrangement of the trunk groups on the selector frames. This is a very important matter, inasmuch as it allows the selectors to be used to full efficiency. It provides the desired flexibility for growth and permits any desirable rearrangement of the trunks on the selector frames that the telephone company may find desirable at any time.

4. The sender is capable of distinguishing the class of office at which the connection terminates. That is, if the call is to terminate at a mechanical office, the sender will arrange to govern the selection accordingly. If the call is to terminate at a manual office, the sender recognizes this and arranges to send out impulses to the call indicator equipment in the manual office.

5. For the completion of certain calls, traffic conditions require the introduction of tandem centers as discussed later. The sender recognizes calls to be routed via tandem centers and arranges to handle these correctly. The tandem center may be manual or it may be mechanical, and the control must be determined accordingly.

6. Certain senders are arranged to serve lines supplied with coin boxes. These senders are arranged to make a test to determine whether a coin has been deposited and do not allow the connection to be cut through so that conversation can take place until the coin is deposited. If the subscriber does not deposit the coin, after a reasonable time has elapsed the sender connects an operator to the subscriber, and this operator notifies the subscriber of his omission. After the

coin has been deposited, the sender allows the called subscriber to be rung and permits the conversation. In case the called subscriber is busy or does not answer, or if the call is to a free line, the sender returns the coin to the calling party. If the called party answers, the sender causes the coin to be collected.

The sender makes a test of the calling line after the subscriber has completed dialing, to insure the deposit of the coin, and recognizes whether a coin has actually been deposited or whether some abnormal condition exists, in which case the call will be routed to an operator who causes an investigation to be made.

7. In large areas, such as the New York Metropolitan area, there are distant points, connection to which requires toll charges. In such cases the subscriber is instructed to dial a special operator who will ascertain his wishes, complete the call, and make the proper charge. Should a subscriber attempt to dial outside of his own local service area, his call will automatically be routed to an operator.

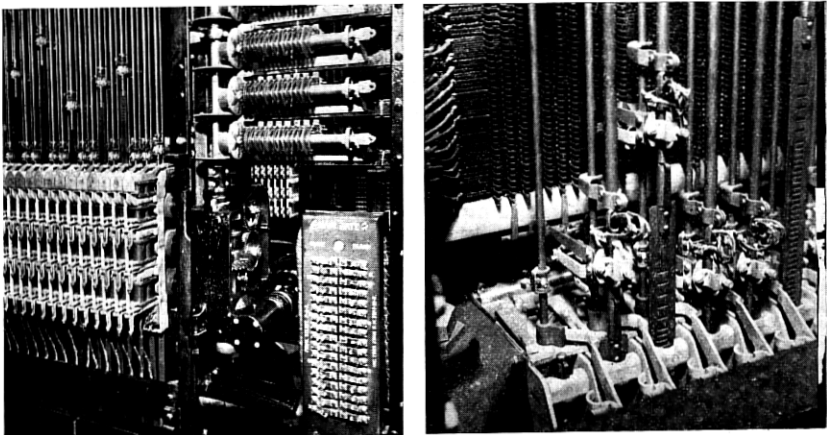

Fig. 9—Views of the Selector

Panel Type Selecting Mechanism. An important mechanism of a machine switching system is the selector and its associated multiple bank. It is a device by means of which trunks or lines are connected together as required. It performs the same function as the switchboard cord and plug, which in a manual exchange can be plugged by the operator into any one of a number of jacks which are the terminals of trunks or lines.

Fig. 9. shows the mechanical elements of the selectors. The movable member corresponds to the cord and plug of the manual system

and the fixed terminals or multiple, to which the movable member can make connection, corresponds to the jacks of the manual system.

Fig. 10 shows the fixed terminals or multiple to which the selectors connect. This multiple consists of flat punchings about $3\frac{1}{2}$ feet long and 1 inch wide overall. Each of these strips has lugs on each side with which the selectors can make contact. In this particular panel, three hundred of these strips are piled one above the other, separated by insulation, and securely bolted together, forming a panel about 15 inches high. This panel provides a multiple consisting of "tip," "ring" and "sleeve" connection for one hundred lines appearing sixty times; that is, thirty on each side. The insulating material consists of special impregnated paper and is of such a nature that,

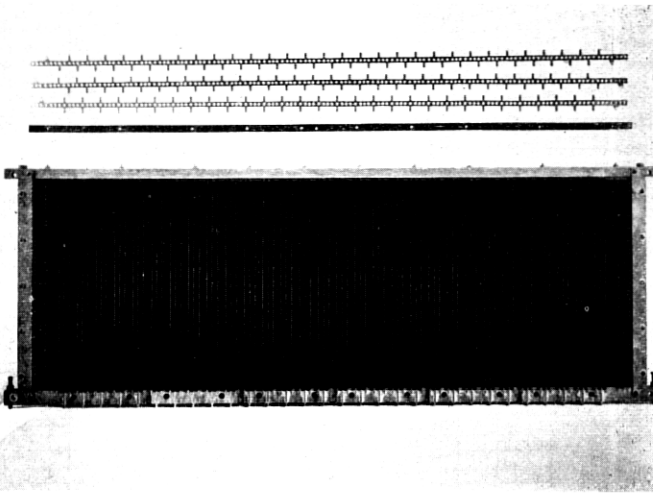

Fig. 10—Selector Multiple Bank

after the panel is assembled and baked, it becomes inert and is not adversely affected by any conditions met with in a central office. It is this panel which has given the name to the system.

The selector (see Figs. 9 and 13) consists of a metal tube supported in bearings allowing vertical motion and carrying five sets of brushes. Each one of the five sets of brushes is arranged to make connections to the tip, ring and sleeve terminals of the panel banks before which it normally stands, and the tip, ring and sleeve contact members of all five of these brushes are multiplied together. They are normally free from contact with the terminals, but any set may be tripped me-

chanically, so that that set will contact successively over terminals as the selector rises.

A friction clutch is provided at the base of each selector, so arranged that the selector can be raised or lowered by power supplied by a constantly rotating small motor, common to 60 selectors. A magnet is also provided for tripping, by means of a rotating rod, any one of

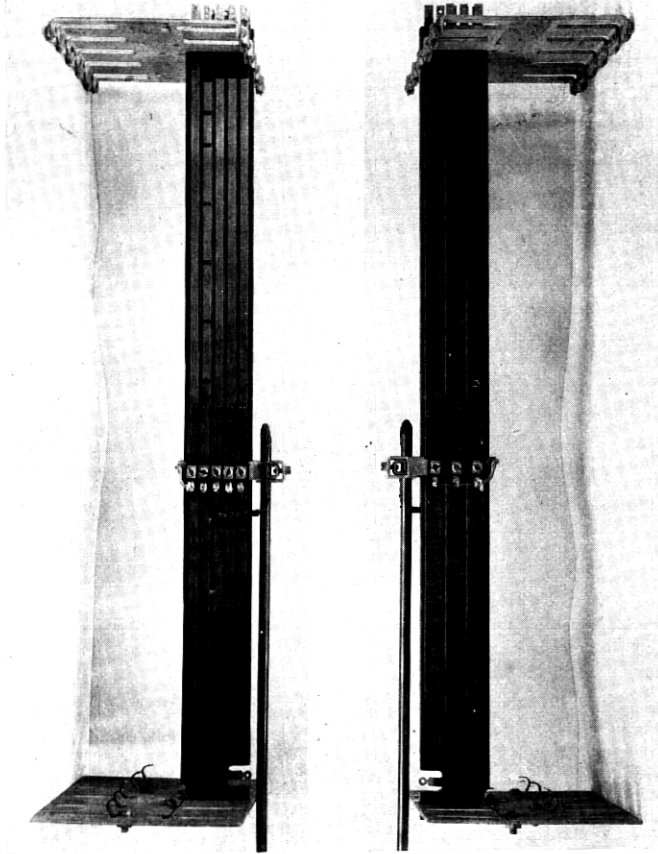

Fig. 11—Commutator for Controlling Vertical Movement of Selecting Mechanism

the five sets of brushes into mechanical engagement with the terminals. In choosing a trunk or line, that one of the five sets of brushes which has access to the panel in which the desired trunk or line happens to be, is tripped so that it makes contact with the bank terminals before it. The selector then moves upward, under the proper control,

until the tripped brush engages the desired line or trunk. The selector is then held in this position by a pawl associated with the clutch. When the connection is to be taken down, the pawl is withdrawn, and the selector is carried back by means of the power drive controlled by the clutch. When the selector reaches its normal position the tripped brush is reset.

Selectors used for different purposes are arranged to move their brushes upward at different speeds. The speed most commonly employed moves the brushes over the terminals at the rate of 60

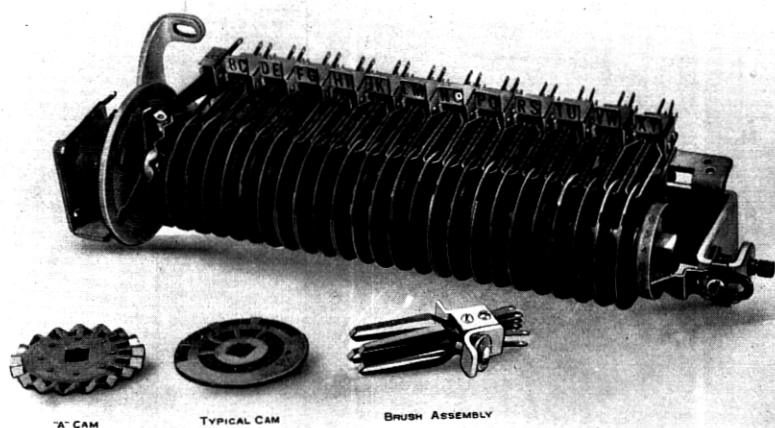

Fig. 12—Sequence Switch Assembly

trunks per second. At the top of the frame, just above the fifth bank, are located commutators as shown in Fig. 11, one for each selector. The multiple wiring of the brushes on the selector leads to other brushes which move over strips on these commutators, and thereby completes the connection from the movable selector to the rest of the circuit, thus avoiding flexible wire connections with their attendant troubles. This commutator, also, performs the more important service of controlling the travel of the selector. Brushes moving over conducting segments separated by insulation produce

impulses which, when sent back to the sender, indicate to it the exact position of the selecting mechanism.

Sequence Switch. Another device of great importance is the "sequence switch," shown in detail in Fig. 12. It is operated through

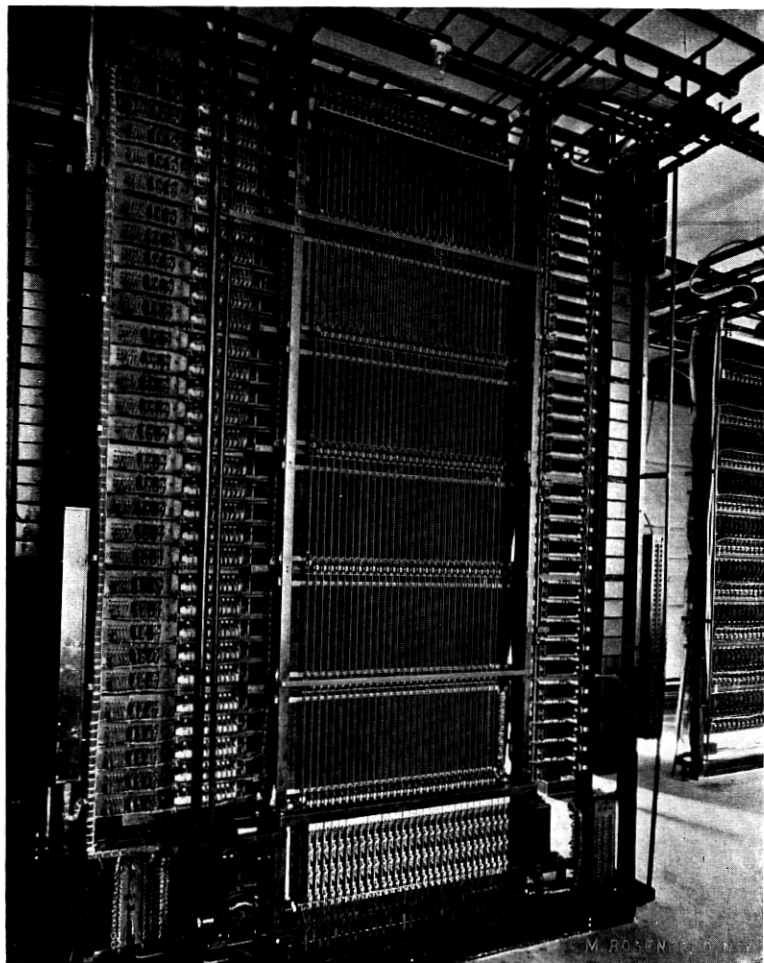

Fig. 13—Selector Frame Completely Equipped

an electromagnetic clutch from the same motor that drives the selectors.

The sequence switch may be described as a circuit controller or device whose function is to establish in a definite sequence such circuit

conditions as are required in the operation of the system. It is made up of circular disks called cams mounted rigidly on a shaft. The plates of the cams are cut so that brushes come in contact with the plates only when the circuit is to be closed. The sequence switch can be stopped at any one of eighteen different positions as required, by the simple opening of the electromagnetic clutch.

There are many of these sequence switches used in this system, and the arrangement of cutting the cams varies, depending upon the particular circuit combinations which it is desired to establish.

Selector Frames. Fig. 13 shows thirty selectors with all of the associated mechanism mounted upon one side of a frame ready for operation in an exchange. Both sides of the frame are alike. Five panels of 100 lines each are mounted in this frame, one above the other giving a total capacity of 500 trunks or lines. Thirty selectors, each capable of making connection with any one of the 500 trunks or lines, are placed adjacent to each other on each side of these panels; the entire frame thereby having a capacity of sixty selectors, each of which has access to 500 trunks or lines.

Immediately to the right of the selectors are the sequence switches and, under protective covers, such relays as are used in connection with the selectors upon the frame shown.

Selecting apparatus of this general type, but differing in details of design, is used during the different stages of the call as line finders, district selectors, incoming selectors and final selectors, reference to which has been made before. Fig. 14 shows a section of a machine switching office with some of the typical frames.

The use of apparatus of the substantial construction just described is made possible only through the use of the sender which receives impulses from the subscriber at the rate they are dialed and receives impulses from the selecting mechanism at the rate it is traveling. This obviates the necessity for restrictions in the design of either the dialing circuit or the selecting circuit, such as would be necessary if they were tied together.

Power Supply Arrangements. Since most of the operations normally required in handling a call in a machine switching office are carried out mechanically, it is evident that a considerably larger amount of power is required than with the manual system. Selectors and sequence switches are propelled mechanically by rotating shafts driven continuously by small motors mounted on each frame.

The use of small motors on each frame gives a flexible and reliable source of power particularly since the motors now being used are of the special "duplex" type developed for the purpose. They consist

of two motor elements in one frame, one element being normally driven from the commercial power service and the other being driven by the telephone reserve storage battery to which it is automatically

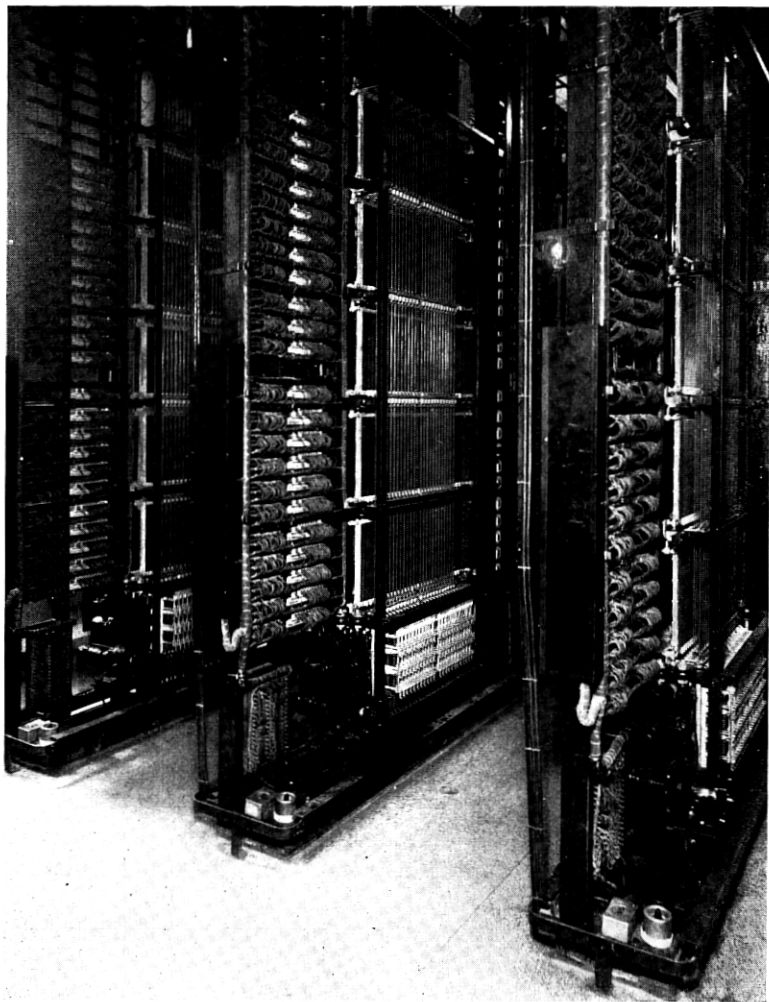

Fig. 14—Group of Typical Selector Frames

connected by a relay inside the motor when the regular power fails. A power failure, therefore, causes no interruption to the drive. The selectors are arranged so that not more than half in any one group are

driven by the same motor which insures continuous service in case of motor failure.

The main power requirement is for direct current at about 24 and 48 volts which is furnished from motor generator sets (Fig. 15) of special construction to reduce noise, converting the commercial alternating or direct power current into current which is regulated as to voltage and is free from variations which would cause noise in the telephone circuits.

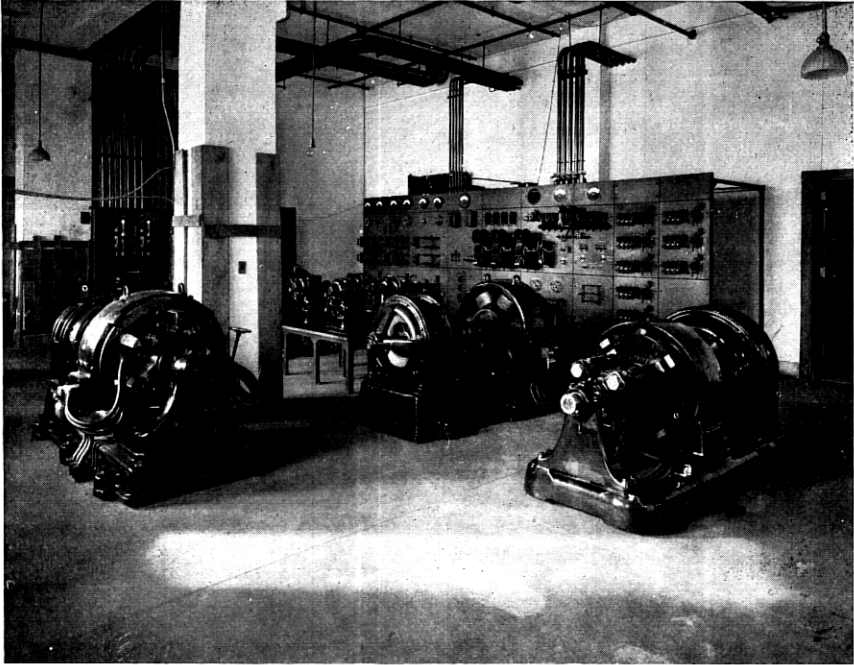

Fig. 15—Power Machine and Control Equipment for Two 10,000-Line Units

Storage batteries (Fig. 16) floating across the current supply bus-bars insure regulation. In addition to stabilizing the voltage and reducing noise interference from the machines and between telephone circuits, the batteries perform the important function of keeping the exchange in operation during interruptions to the commercial power service. Small motor generators furnish current for ringing subscribers' bells and drive commutators supplying various tones and signals. Batteries or machines supply current for operating coin

boxes and pulse machines provide impulses for the operation of certain of the machine switching apparatus.

Whenever practicable, two or more commercial power services from independent generating stations are secured, either of which will keep the office supplied. Where independent generating systems are not available a reserve gas engine supply (Fig. 17) is installed to take the place of the incoming power service, such engine also being equipped for emergency operation on gasoline.

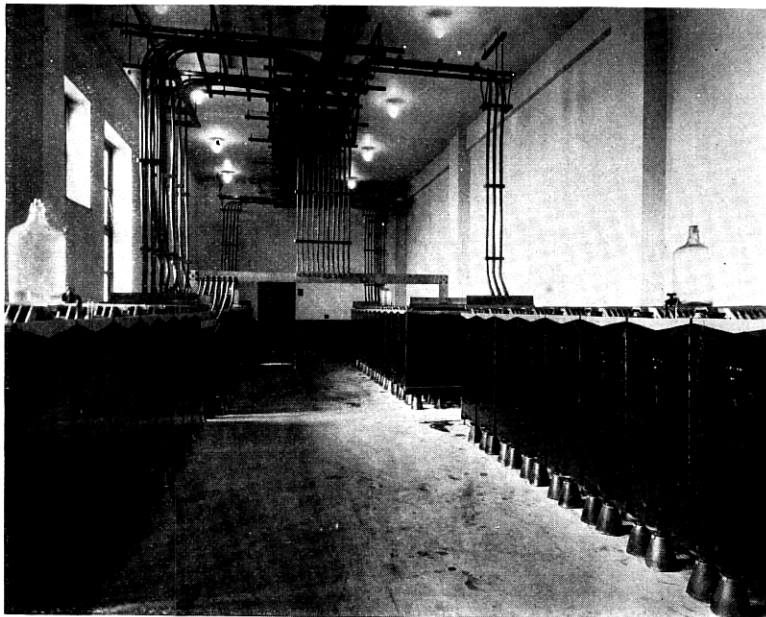

Fig. 16—Battery Room for Two 10,000-Line Units

All of the essential power machines and batteries are provided in duplicate and are arranged to come into action automatically wherever this is necessary to insure continuity of service in the event of loss of power or trouble with any of the power equipment. Alarms are provided to detect variations in battery voltage, blowing of fuses, stopping of machines or any failure of service on all power busses which feed energy to the telephone or signaling circuits. The power plant is thus designed to give an uninterrupted energy supply at all times even when the usual sources of power may have been temporarily discontinued.

DETAILED PLAN OF OPERATION

The following will give in some detail the plan of operation for handling typical calls between various types of offices in a large metropolitan area such as New York City.

Calls Originating in Machine Switching Offices. Fig. 18 shows schematically the path of a call originating in a machine switching office. The pair of wires of a subscriber's line is attached to one of the sets of fixed terminals in a panel bank appearing before a group of selectors of the type which has been described. By putting fewer

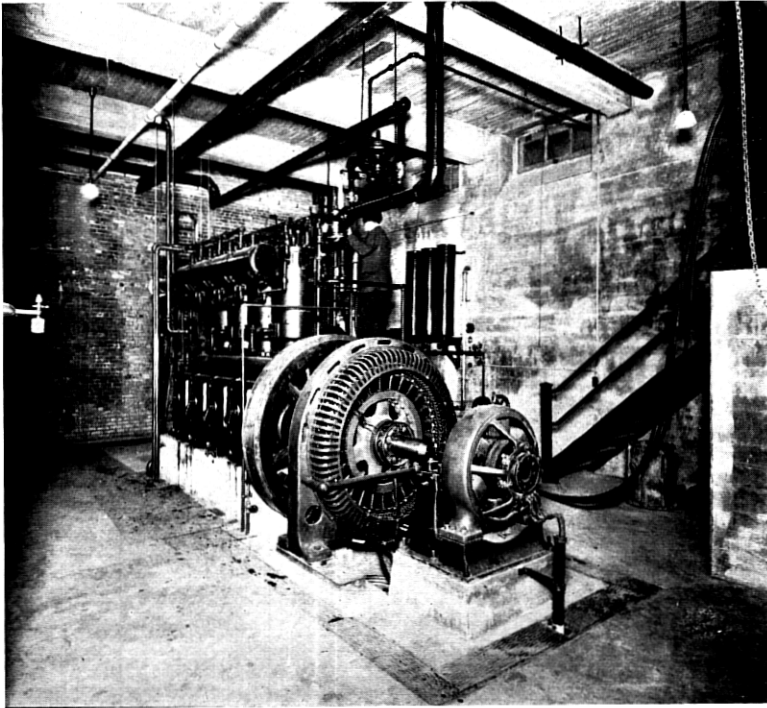

Fig. 17—165 H. P. Gas Engine Generating Set for Emergency Use

lines in these panels and increasing the number of selector brushes, we attain the speed necessary at this stage of the connection. These selectors are called "line finders," since their function is to find calling lines. The terminals correspond to the answering jacks and the selectors to the "A" operators' answering cords of the manual system.

When the subscriber removes his receiver, he closes the circuit of his line, causing a relay at the central office in series with his line, to operate. This relay causes an idle line finder, having access to his line, to trip the proper brush and then move upward to his line. At the same time a sender selector attached to that line finder is choosing,

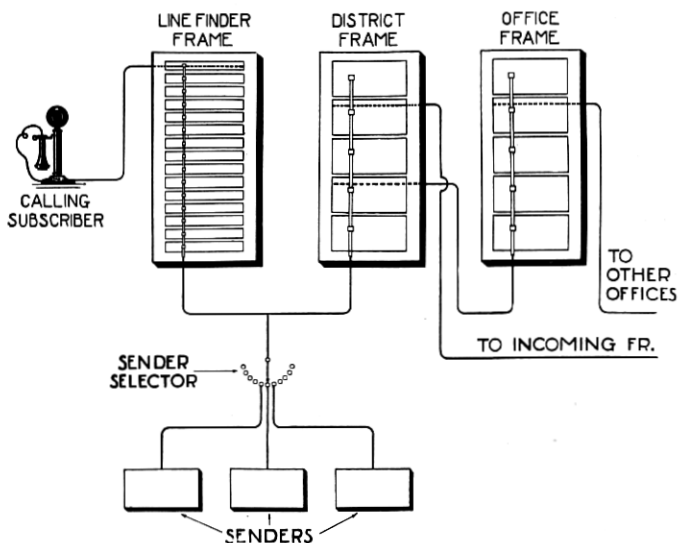

Fig. 18—Diagram of Line Finder, District and Office Frames

out of a common group, an idle sender. The sender selector is a small selector of a type in which the brushes are driven by a magnet over contacts arranged as shown in Fig. 19.

The sender having been attached in this manner to the calling line, a low humming sound, known as the dial tone, is heard by the subscriber, advising him that the mechanism is ready for him to dial. The entire sequence of events just described takes place in a fraction of a second, so that ordinarily the subscriber finds the dial tone when the receiver reaches his ear. The subscriber now dials the required letters of the office name, and the numerals of the called number.

The pulses from the dial come over the subscriber's line through the line finder and sender selector to the sender which records and translates them to control the setting up of the connection. As soon as the connection has been established, the sender is released and is ready to be used for a new call, being kept in use only a few seconds for each call.

The first step in completing the connection is to choose an idle trunk in the proper direction. To the nearby offices there are groups of direct trunks, whereas the more distant offices are reached through tandem centers described later.

The line finder leads to the movable element of a panel selector known as a "district selector." This district selector has capacity for 450 working outgoing trunks, the other 50 trunks being used for control purposes. In a small city 450 trunks would be sufficient to

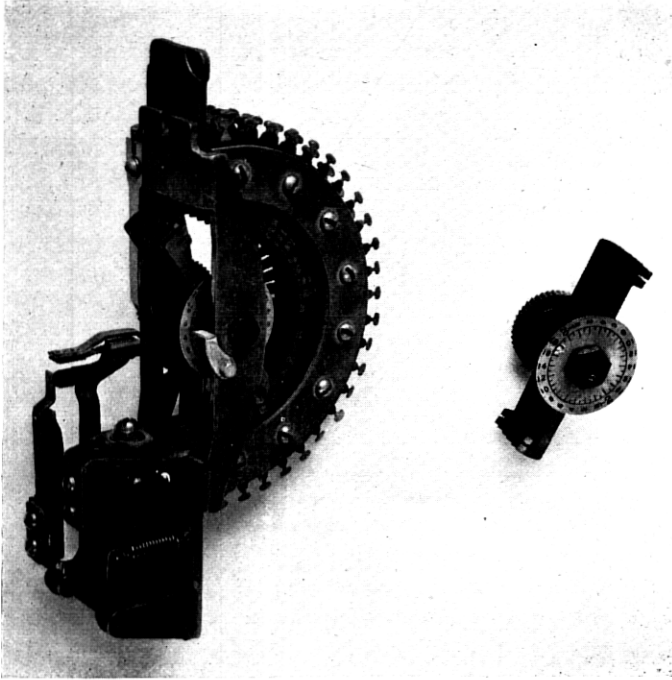

Fig. 19—Sender Selector

reach all points, but in the case of the New York offices 450 outgoing trunks are not sufficient. Accordingly, only a few of the trunk groups outgoing from these offices leave directly from the district selectors. To obtain access to the remaining trunks there are, on every district selector frame, groups of trunks leading to so-called "office selectors." These office selectors are of the panel type and each has a capacity for 450 outgoing trunks.

The path of a call through a district and office selector will now be traced. The district selector starts upward under the control of the

sender. As the district selector moves upward, it produces pulses by means of the brushes which slide over the commutator at the top of the selector. These pulses are transmitted back to the sender, and are there counted. When the sender has counted the number of pulses which indicates to it that the district selector has proceeded to the proper position, the sender opens the fundamental circuit to the selector and causes it to stop. This method of controlling the movement of the selector is termed the reverse control method.

The first selection made chooses the set of brushes to be tripped into engagement with the terminals. Assume, as shown in Fig. 18, the desired trunk appears on the second panel from the bottom. Therefore, the district selector is allowed to make two pulses and is then stopped by the sender. The brush-tripping device is thus set in position to trip the second brush, and the selector is started again by a signal from the sender, which operation completes the process of tripping the brush.

The selector now continues upward, making a pulse for every group of trunks which it passes over, until, having reached the desired group, as indicated by the number of pulses counted by the sender, it is again stopped by the sender at the beginning of this group. The selector is now started again, and this time under its own control, hunts for an idle trunk in the group. Busy trunks are grounded on the third or signaling terminals, whereas idle trunks are open. A testing relay, associated with the selector, keeps the selector moving upward until a trunk with an open third wire is found, whereupon the selector stops, makes connection with this trunk, and renders it busy to other selectors by grounding the signaling strip.

This trunk, as indicated in Fig. 18, leads to an office selector. The same process is repeated by the office selector, under control of the sender, to trip first the proper brush, then choose the proper group, and finally to choose an idle trunk in the group. The connection is now extended to an outgoing trunk. The sender still remains attached to the connection, since it must still control the further setting up of the connection.

The sizes of the working trunk groups on district and office selectors can vary from 5 to 90, depending upon the traffic to be handled.

Calls Between Machine Switching Offices. If the call is for a subscriber in a machine switching office it is completed as shown in Fig. 20. This figure shows a diagram of the apparatus used to connect an incoming full mechanical trunk to a subscriber's line, whether this line is in the originating machine switching office or in another which must be reached over interoffice trunks.

The incoming trunk to the machine switching office terminates on an "incoming selector," which is of the type already described. The machine switching office has a capacity for 10,000 numbers, but the incoming selector has capacity of only 500 trunks, so that the same arrangement is employed as on the district selectors; that is, the incoming selector chooses one of a number of other selectors, called "final selectors," which have access to the subscribers' lines. Since each group of final selectors has access to 500 subscribers, 20

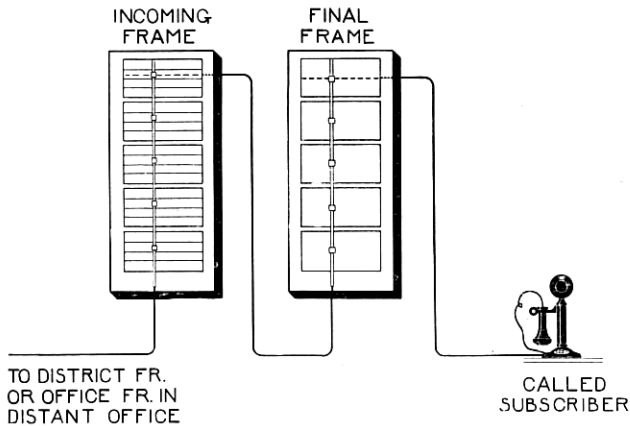

Fig. 20—Diagram of Incoming and Final Frames

groups of finals will be necessary to care for the full 10,000 numbers. On the incoming selector frames, therefore, appear 20 groups of trunks, each group leading to a different frame of final selectors.

The method of selection is the same as described for the district and office selectors; that is, first the incoming selector, under control of the sender in the originating office, trips the proper brush, chooses the proper group, and finally chooses an idle trunk leading to a final selector. The final selector then goes through the process of brush, group, and subscriber's terminal selection. The terminal selection is under the control of the sender which counts line by line in the group of ten, until the desired one is reached. If the called line is idle, it is rung, and the calling subscriber is advised of that fact by hearing the audible ringing signal. If the called line is busy it is not connected, but an intermittent buzz, recognized as the busy signal, is sent back to the calling subscriber. If the called number is that of a P. B. X. having several trunks, the final selector automatically hunts for an idle one. If the final selector, after testing all the P. B. X. trunks finds them all busy, it sends back the busy signal.

As soon as the called line is reached, the sender is dropped from the circuit to be available for another connection. It is not held during the period of ringing, during the time that the busy signal is being given, if the line is busy, or during any part of the period of conversation.

It will be noted that the method of selection is not on a decimal basis. The first selection is to choose one of five brushes on the incoming selector as already explained; that is, we choose that particular fifth of the terminals in which the called line happens to be, and since 1-5 of 10,000 is 2000, we choose the 2000 group desired. The next selection is by groups of 500, which is again non-decimal. This "translation," as it is called, of the number from the decimal notation, as dialed by the subscriber, into the notation as needed by the selectors, is taken care of very simply in the senders.

Calls from Machine Switching to Manual Offices. Calls from machine switching to manual offices are handled at the manual office on call indicator "B" positions. Fig. 21 shows a diagram of the equipment used to connect such a call to a subscriber in the manual office.

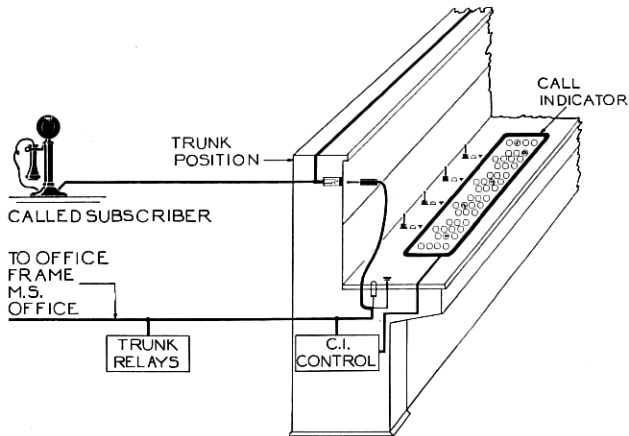

Fig. 21—Diagram of Connection from Machine Switching to Manual

The call progresses through the district and office selector in the same manner as described for the machine switching call, but the trunk which it takes up leads to a call indicator "B" position in the manual office selected. The operator is notified that a call has reached her position by the lighting of a lamp associated with the cord and plug in which the incoming trunk terminates. Upon perceiving this signal, she presses a display key associated with that trunk, and thereupon the called subscriber's number is displayed on a bank

of numbered lamps located on this operator's keyboard. The operator picks up the plug, tests the called line and, if it is found idle, plugs in; or, if it is found busy, she plugs into a special jack which is arranged to send the intermittent busy tone back to the calling subscriber.

The called subscriber's number is displayed in the following manner. Associated with the operator's position, and with her call indicator, is a group of relays. When the display key is depressed, this group of relays is attached to the trunk. The sender which has meanwhile been waiting on the connection, is thereby given a signal, and sends the number called by means of code pulses which are received by the group of relays. These relays, in turn, light the set of lamps on the call indicator corresponding to the digits of the called number, as shown in Figs. 22 and 23. The code pulses employed for sending

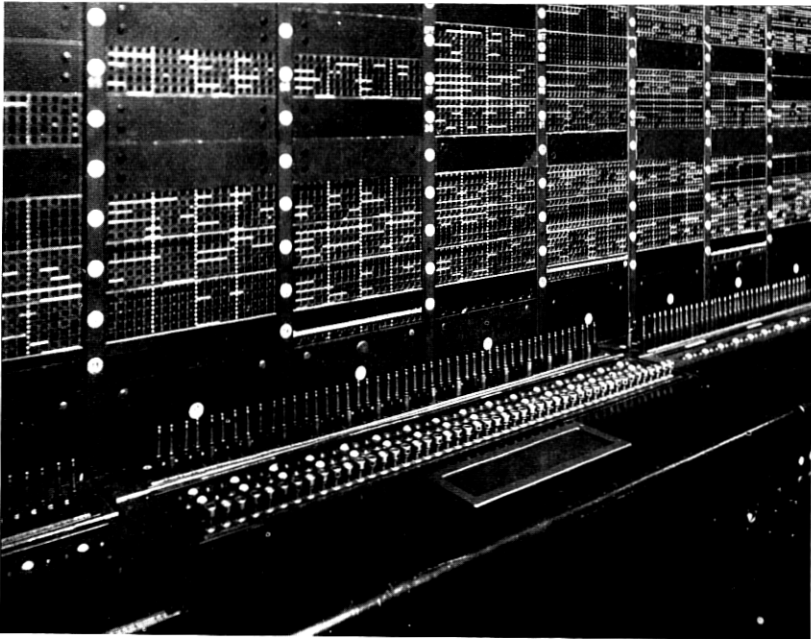

Fig. 22—Incoming Trunk Position in a Manual Office Arranged for Call Indicator Operation

this called number are positive and negative, strong and weak, and are translated by the sender from the decimal dial pulses to this type of pulse to reduce the time required and to simplify the receiving apparatus.

Incoming Calls from Manual to Machine Switching Offices. Calls from manual offices are handled at the machine switching office on the cordless "B" positions. Fig. 24 shows a diagram of the equip-

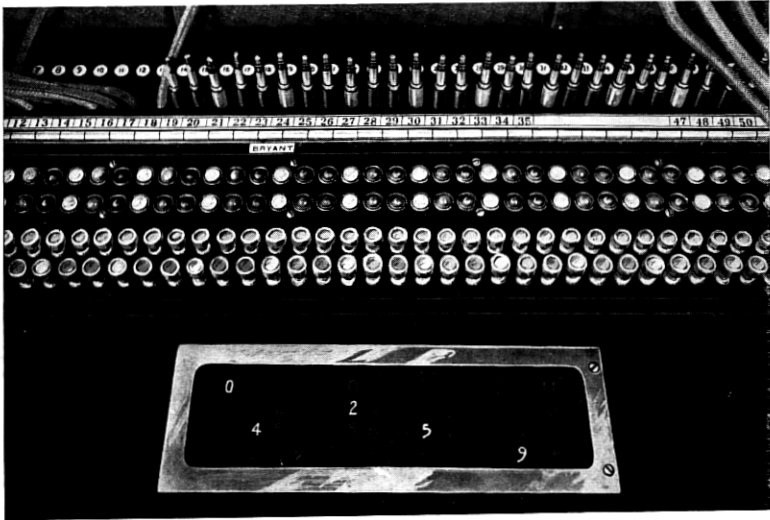

Fig. 23—Call Indicator at an Incoming Trunk Position in a Manual Office

ment used to connect a call originating in a manual office destined for a subscriber in a machine switching office. Such a call is answered by the "A" operator in the manual office in the usual manner. She takes up the call circuit by depressing her call circuit key to the

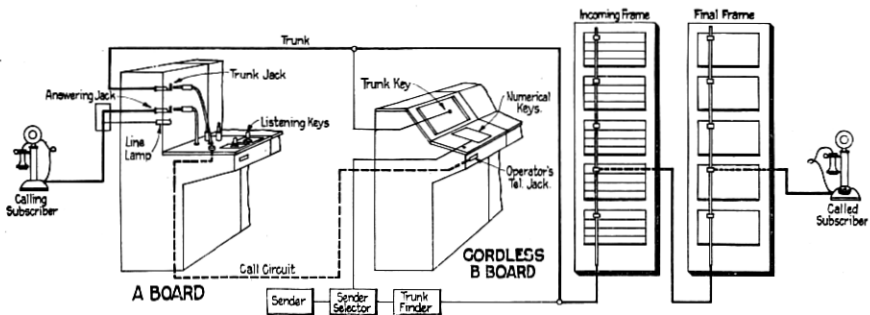

Fig. 24—Diagram of a Connection from a Manual to a Machine Switching Office

machine switching office desired, passes the called subscriber's number, and receives a trunk assignment in exactly the same manner as if the call were going to another manual office. The cordless "B"

operator, upon assigning a trunk, presses the assignment key of that trunk, which temporarily attaches her keyboard to a sender and simultaneously to the incoming trunk which she has assigned. As shown in Fig. 24, the incoming trunk terminates on an incoming selector which has access to final selectors on which the called number appears, in the same manner as described before.

The operator now sets up on her numbered keys the number desired, and this information is transmitted immediately to the sender. These keys, which lock mechanically, are released after a fraction of a second by a magnet controlled by the sender and are ready for the

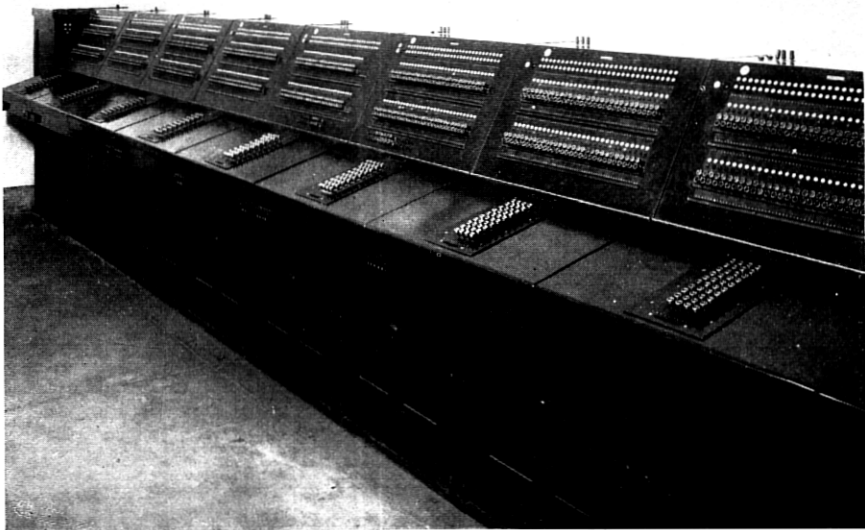

Fig. 25—Cordless "B" Positions in Machine Switching Office

next call. The "B" operator's sender now controls the incoming and final selectors in the same manner as the subscribers' senders, causing the incoming selector to choose an idle trunk to a final selector having access to the desired group of 500 numbers. The final selector reaches its destination in the manner previously described and, as soon as the line is found, the sender is released.

Fig. 25 shows a line of cordless positions. The section at the left is the cable turning section, having nothing to do with the operation of the board.

Manual Positions Required in Machine Switching Offices. While regular calls between two subscribers will be completed in this system without the aid of operators, certain classes of calls, such as toll calls to suburban points and calls for discontinued or changed numbers, etc., will require the assistance of an operator. Special manual positions are therefore provided in the machine switching office for this service. These positions also care for cases where the subscriber may need the assistance of an operator for other reasons than the above, and are in addition to the cordless "B" positions previously described.

The operators are called "Special Service Operators." The subscriber signals them by dialing "Zero," which on the dial is also marked with the word "Operator." The connection then progresses in the same general manner, through the district and office selectors, as for any originating call. An idle trunk appearing on the office selector leading to an answering jack before the special service operator is chosen and the sender released. Should a subscriber in any local service area dial a subscriber in another area, the sender will automatically route the call to a special service operator.

The special service operator in large areas has before her a number of cord circuits having one end terminating in a cord and plug. She also has upon a keyboard a set of keys similar to those described for the cordless "B" position, except that there are additional strips of keys upon which she can write up an office code. The operator answers the subscriber by inserting one of the plugs in the answering jack and, having ascertained the desires of the subscriber, directs the connection to the proper destination by setting up on her keys the proper numerical code. Senders are furnished for these positions so that, as soon as the information from the keyboard has been registered on the sender, the keys are released and are ready for another call.

The other end of the special service operators' cord circuit terminates in a district selector which, either directly or through other selectors, has access not only to trunks which the subscriber himself might call, but also to trunks leading to more distant offices which he cannot dial directly because they are toll points.

Tandem Operation. There are about 158 central offices in the area shown on the map, Fig. 3. While it is an essential requirement that any subscriber connected to any of these offices be able to reach any subscriber connected to any other office, it is obvious that to furnish trunks from each office direct to every other office would require a great number of long trunks in small groups carrying a very light load most of the time.

In order to eliminate the inefficiency that such an arrangement would entail, it has been the practise in manual operation to handle the traffic from one part of the area to another part of the area over main trunk routes. The collecting and distributing points on these trunk routes are known as "tandem centers," and the plan of operation is known as "tandem operation."

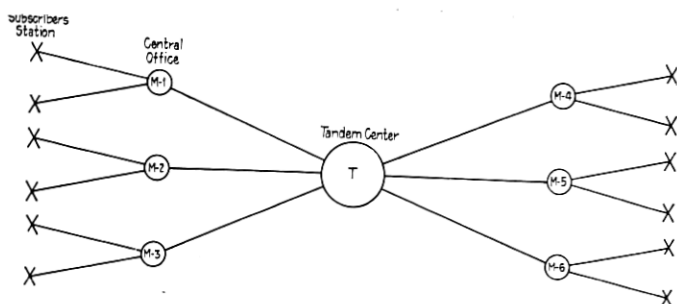

Fig. 26—Typical Tandem Trunking Plan

Fig. 26 shows an arrangement of offices in a typical tandem trunking plan. Offices marked *M* are local offices, either manual or machine switching. The office marked *T* is a tandem office. If a call is originated by a subscriber in office *M-1* for a subscriber in offices *M-4*, *M-5*, or *M-6*, to which no direct trunks are provided, the call is routed at office *M-1* to trunks terminating at tandem office *T*. At this point they are connected to trunks leading to the proper office, where the connection is completed to the desired subscriber in the usual manner. Likewise, calls from offices *M-2* and *M-3* are completed over the same groups of trunks from the tandem office *T* to offices *M-4*, *M-5*, or *M-6*.

The plan described above is typical of that followed in the New York Metropolitan area for many years, the completion of the call being controlled at the tandem office by operators.

The machine switching system is not only adapted to fit into the existing tandem plan, either when used in the local central office or at the tandem office, but also makes available possibilities for considerably extending the field of usefulness of the tandem system, due to certain advantages in handling calls at tandem points by the use of machinery.

The use of a sender at the machine switching office which is capable of routing a call in any way desired permits locating the selectors which have access to the interoffice trunks at any convenient point either at the originating office or at some distant point. In other

words, the tandem office T shown on Fig. 26 may consist of a group of office selectors such as have been described previously. In this case the trunks from offices M-1, M-2 and M-3 would lead from district selectors in these offices to the office selectors at office T which would select, under control of the sender in the originating office, an idle trunk to office M-4, M-5, or M-6, as desired. At the terminating office the call would be completed through incoming and finals if it is a machine switching office, or call indicator "B" positions if it is a manual office, exactly as described previously.

If the number of points to be reached through the tandem office is greater than the capacity of a group of office selectors, a group of district selectors may be provided at the tandem office which have access to groups of office selectors located at the same office or at some distant point, as described above.

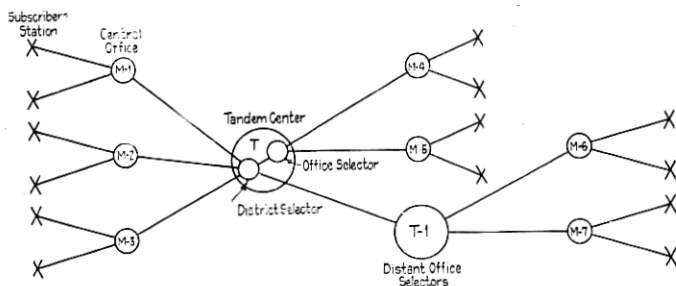

Fig. 27—Tandem Trunking Plan Showing Distant Office Selector

Fig. 27 shows schematically a tandem plan using the above method. Tandem office T is provided with district selectors on which terminate trunks from local office M-1, M-2 and M-3. These selectors have access to office selectors in the same office through which offices M-4 and M-5 are reached, and to office selectors located in the distant tandem office T-1 through which office M-6 and M-7 are reached.

To handle calls at a machine switching tandem office originating from manual offices, operators are required at the tandem office. These operators handle calls in much the same manner as cordless "B" operators in a machine switching office, as already described. The operator receives the desired office name and number from the originating operator over a call circuit and sets it up on her keyboard, which is similar to the cordless "B" board, except that it has office keys in addition to numerical keys. The number is received by a sender which then controls the operation of the selecting mechanism in the

tandem office and other offices through which the call may pass, to the desired local office and subscriber's line.

Many different combinations of the above are possible and are employed when desired.

MAINTENANCE

As will have become apparent from the description already given there is, in the machine switching telephone central office, a large amount of apparatus which, in order to insure service of good quality, must be maintained in proper working condition. Consequently, the subject of maintenance has been very carefully kept in mind throughout the design of the system. For instance, all new pieces of apparatus used in this system have been subjected to the most rigid tests to insure that they will have a satisfactory life and that their margins of adjustment will be adequate.

When maintaining machine switching equipment, the main reliance is placed on preventive measures, so that incipient faults will be detected and corrected before they have got to the point of interfering with service. Ingenious automatic testing arrangements have been designed to aid in this preventive maintenance work. They subject the various circuits in the exchange to routine tests, and are arranged so that they will automatically test all of the circuits, one by one, under conditions more severe than they will ever be called upon to meet in service. In case some feature of any circuit has deteriorated from its normal standard of adjustment—which includes a wide margin—so that it will not meet this severe testing condition, the testing apparatus automatically stops and by supervisory lamps indicates the location of the trouble. An audible alarm is also sounded which notifies the maintenance man responsible that something requiring his attention has been found. The circuit in trouble may still be capable of giving service, but is below the standard set and may soon give service trouble if not corrected.

As applied to the sender, for example, the automatic routine test equipment picks up each sender in turn and puts it through its regular process of operation, under conditions more severe than are encountered in practise. If the sender under test meets the operating conditions without failure, the sender is dropped and the test equipment moves to the next sender. If any trouble develops an alarm is given, which summons the maintenance man who is able to determine by the condition of the apparatus the location of potential trouble.

The operation of the testing equipment may be varied by suitable keys, so that all the features of each sender may be tested once, or so that any one feature of the sender may be tested as many times as desired.

All the equipment in the office occurs in groups, and arrangements are made for readily taking out of service for readjustment any piece of apparatus which may have been found to have potential trouble—the other members of the group continuing to handle the calls.

APPLICATION

In the preceding pages there has been briefly described a switching system which meets the exacting and complex requirements of telephone service in the largest cities and in which, so far as is practicable, the various switching operations are performed automatically. Only such operators are required in connection with this system as are necessary for handling special classes of service and certain operations in connection with the interchange of calls between manual and machine switching central offices during the transition period.

Variations in the arrangements which have been described have been developed and are available for use whenever the conditions warrant. An illustration of this is the so-called key indicator, which permits the handling of calls from manual to machine switching offices without the aid of the cordless "B" operators. This is effected by providing the operators in the manual offices with special keys and equipment for controlling directly the selection of the subscriber's line in the machine switching office.

This machine switching system marks a very important advance in a development which began shortly after the telephone was invented, and which has been most vigorously prosecuted by the engineers of the Bell System from then to the present time. Throughout this entire development period the tendency has been to introduce automatic methods and apparatus whenever they gave a better result to the public, or whenever they were attended by an economy of any kind.

How this system works has been briefly explained. What arrangements are provided for handling regular machine switching calls, calls to and from existing manual offices, private branch exchanges, etc., has been described. How the introduction of this system into a telephone network is affected will now be discussed briefly.

Obviously, the problem of introducing machine switching equipment into such an extensive and complex structure as is the telephone

plant of a big city, is a large one. It is impracticable to introduce it all at once. Its introduction must be effected gradually and this is accomplished by using it for growth and such replacements as are necessary, later extending its use as conditions warrant.

The fundamental engineering studies which have to be made and which must precede the manufacture and installation of the equipment for a machine switching office are, in all important respects, the same as those which must precede the manufacture and installation of the equipment in a new manual office. They involve a careful study of the telephone needs of the area, with a view to determining ultimately the quantities of the different kinds of arrangements necessary to give the service. This requires a study of the commercial requirements at the time when the equipment should be cut over and for several years thereafter. Data must be collected as to the probable rates of calling, the average duration of the calls and the amount of trunking to and from other offices.

With these data available, the size and arrangement of the trunk groups on the selector frames, the number, grouping and type of selectors and senders required, and the size of the power plant can be determined. From this the cabling arrangement can be worked out, and suitable floor plans prepared.

Manufacturing specifications can then be prepared in accordance with which the equipment of the office is manufactured and installed. Before the equipment is cut into service, the various arrangements are thoroughly tested individually, and when in proper condition the whole is checked up by making complete operation tests.

If time and space permitted, it would be of interest to discuss the methods of actually cutting the equipment into service, and the comprehensive program which is worked out for the training of the employees who are to handle the equipment and advising the public which is to use it. All these matters are of the utmost importance, and must be carried out systematically in order that there may be no reactions on the general service at the time of the cut-over.