

# Philadelphia-Pittsburgh Section of the New York-Chicago Cable<sup>1</sup>

By JAMES J. PILLIOD

**SYNOPSIS:** Engineering and construction features involved in a complete telephone cable system over 300 miles in length and connecting Philadelphia and Pittsburgh, Pa., are described in the following paper. This cable is designed to operate as an extension of the Boston-Washington underground cable system with which it connects at Philadelphia. It is also designed for operation in connection with the Pittsburgh-Chicago cable now under construction, and other cable projects included in a comprehensive fundamental plan.

Beginning with the fundamental factor of public requirements for communication service between cities separated by various distances, there are next considered the methods available to provide this service. Small-gauge, quadded, aerial cable, which was decided upon for use in this section after careful economic studies, is described in a general way and the important advantages of the application of loading and telephone repeaters are outlined. The use, in connection with this cable, of the recently developed metallic telegraph system for cables is referred to and some facts are given regarding power plants, test boards and buildings. A few of the many possible combinations of cable and equipment facilities into complete telephone circuits, which will furnish the service required as economically as now possible, are illustrated.

The necessity of complete coordination of the many factors involved in a project of this kind is emphasized.

## INTRODUCTION

THE placing in service in the latter part of 1921 of the final section of a continuous telephone cable over 300 miles in length between Philadelphia and Pittsburgh marked a new point of achievement in the steady development and construction of facilities designed to render to the public the best possible long-distance telephone service. Furthermore, this cable forms an important part of a comprehensive plan of long-distance cable construction throughout that section of the United States lying in general east of the Mississippi River and north of the Ohio and Potomac Rivers.

In the discussion of a project of this kind which involves many new practices and the expenditure of several millions of dollars and which, with related work already completed, forms the groundwork for large expenditures in the future, it is usual to inquire first into the underlying reasons for carrying out the project and then into the methods adopted. In the following discussion an endeavor will therefore be made to furnish some information on these two items in their relation to the Philadelphia-Pittsburgh cable, although, as will be obvious, the many different points can be covered in only

<sup>1</sup> Presented at a meeting of the Philadelphia Section of the A. I. E. E., January 9, 1922, presented at the Annual Convention of the A. I. E. E., Niagara Falls, Ont., June 26-30, 1922, and appearing in the Journal of the A. I. E. E. for August, 1922.

the most general way in the space available. However, before going ahead with the discussion, I would like to point out that this project is not unlike many others in that, as a whole and in the component parts, there have been required, first, the careful consideration and decisions of the executives, then the underlying work of many scientists, inventors and engineers, then the skilled work of the manufacturers and construction forces, and finally the maintenance and operation by trained people who are responsible for the continuous service so vitally necessary to the industrial and social structure of the country. The point to be emphasized here is that the coordination of all of these factors and the close cooperation of all of the many hundreds of people concerned are the important things.

#### GENERAL CABLE PLANS AND ROUTES

Fig. 1 is an outline map of a section of the United States and shows the routes of existing and proposed long telephone cables of the Bell system. It will be noted that the present and proposed routes follow in a general way the routes of trunk-line railroads. This general section contains more than 50 per cent of the entire population of the United States but less than 15 per cent of the area, and the industrial and telephone development is, of course, very great. Furthermore, the nearby surrounding states, supplying as they do large quantities of food products and raw materials, are commercially related to this section in a very peculiar way and this fact greatly influences the long-distance telephone development along the particular cable routes indicated. The routes through the State of Pennsylvania and the offices at Philadelphia and Pittsburgh, which are the terminals of the cable that is more particularly the subject of this discussion, occupy strategic positions in this system.

Circuits of the American Telephone and Telegraph Company and the Bell Telephone Company of Pennsylvania are carried over these routes and this cable was jointly planned and installed by these companies.

Fig. 2 is an outline map of the State of Pennsylvania and shows the situation in this section a little more in detail. On this map are shown some of the larger cities and routes of the longer and more important toll and long-distance telephone lines. As indicated, these lines are mainly of the familiar aerial wire type which has been generally used in the past for this purpose and which is today the most efficient and economical type of construction for many cases. In the general section between Philadelphia and Pittsburgh the

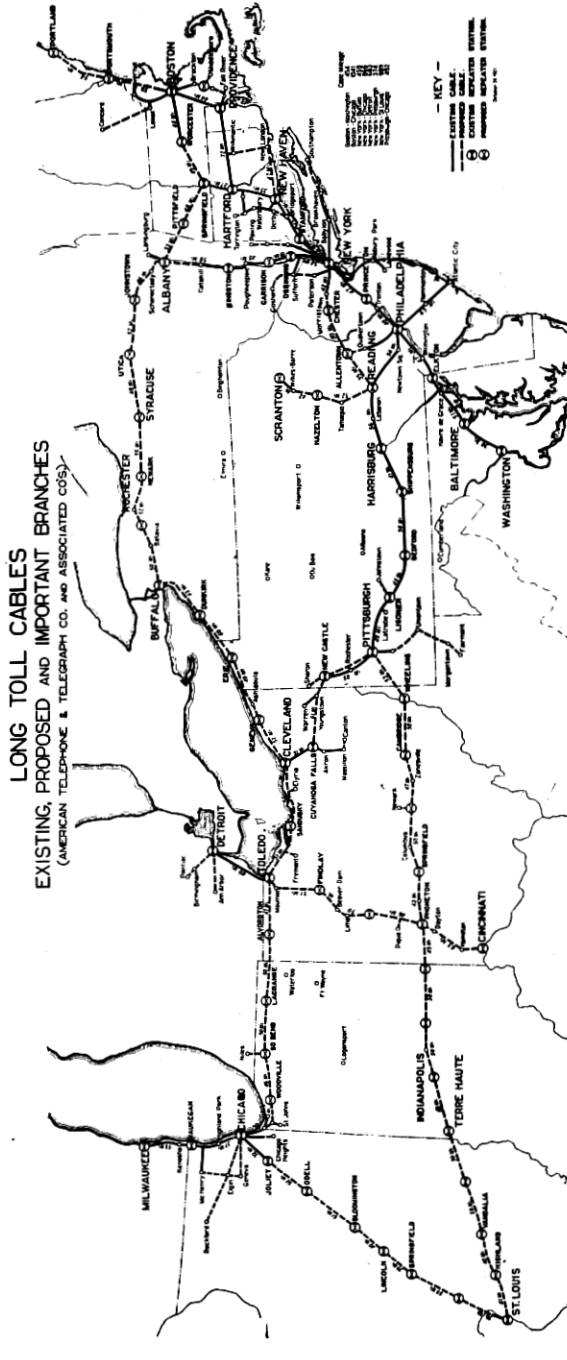

Fig. 1—Routes of Existing and Proposed Long Telephone Cables

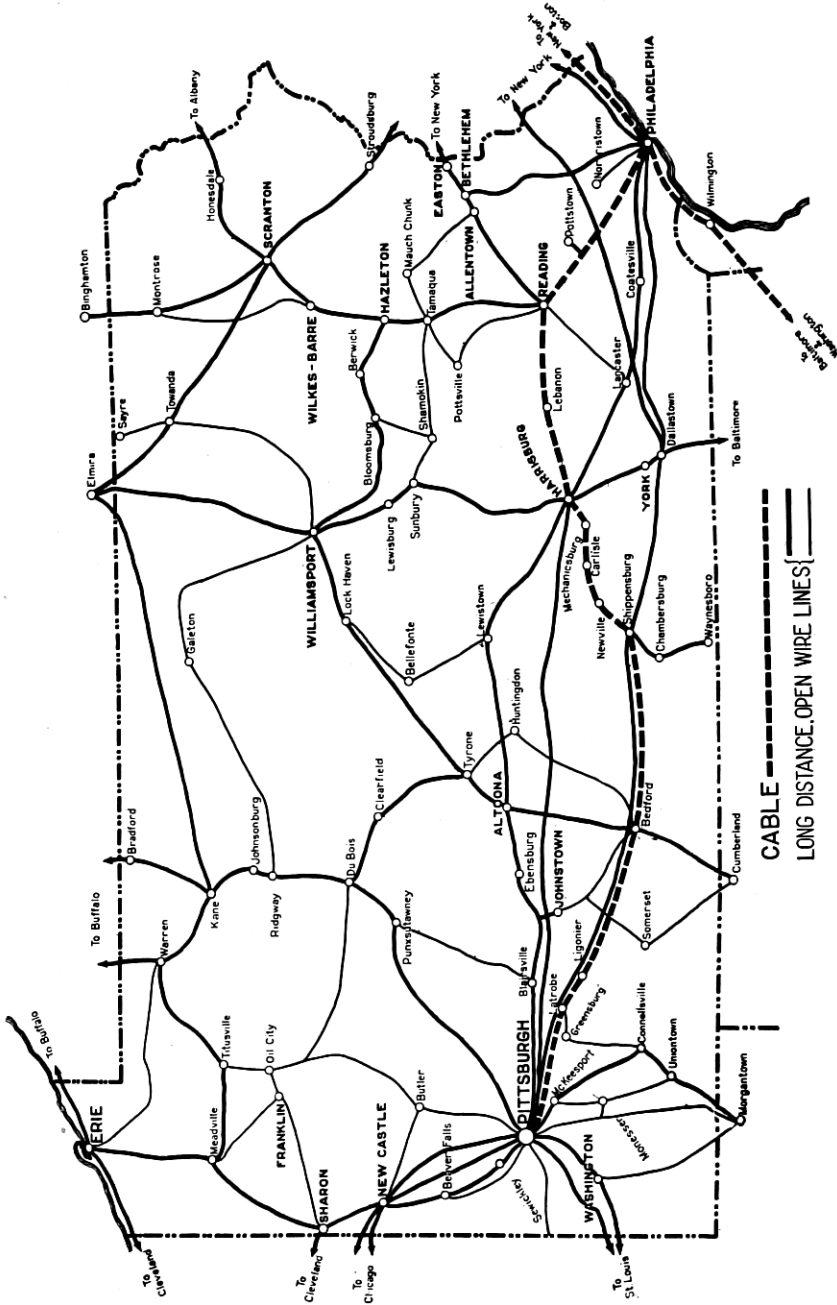

Fig. 2—Outline Map of Pennsylvania, Showing Aerial Line and Cable Routes

requirements for circuits are very heavy and in addition, as is well-known, the topography of the country is such that the through routes which can economically be used for pole lines are limited. At present, these few routes are fully occupied by the pole lines of the various utilities and included in these lines are three fully loaded telephone trunk lines. Another item of importance in the consideration of aerial wire construction is the very severe damage frequently experienced in many sections of the country on heavy aerial wire lines from ice and wind storms. Even lines built with exceptional strength fail in these storms and the interruptions to service are serious matters to the users as well as to the telephone companies. The restora-



Fig. 3—Damage to Section of New York-Boston Main Line Near Worcester, Mass. Storm of November 28, 1921

tion costs under the conditions that naturally exist at such times are abnormally high.

Figs. 3 and 4 show the effects at one point of the ice and wind storm in New England on November 28, 1921, and are proof that this problem is real. This particular spot is near Worcester, Mass., and the line is a section of one of the principal aerial wire routes between New York and Boston. In this storm, many thousands of poles were broken and even where a few poles remained standing due to specially strong construction, the load of ice combined with the wind was too great for the wires to withstand. There is therefore a practical limit to the number of wires that can be safely and economically carried on a pole line.

Where the practicable routes for pole lines are limited, where the

existing pole lines are fully loaded, and where estimated future circuit requirements are of considerable magnitude, it is obvious that different methods of providing facilities, if available, must sooner or later be given serious consideration. The conditions between Philadelphia and Pittsburgh and in general along all of the cable routes shown on Fig. 1 are now, or are expected within a few years to be, such as to make the use of some type of construction other than aerial wire desirable for most of the circuits.

After careful studies of the circuit requirements for future periods

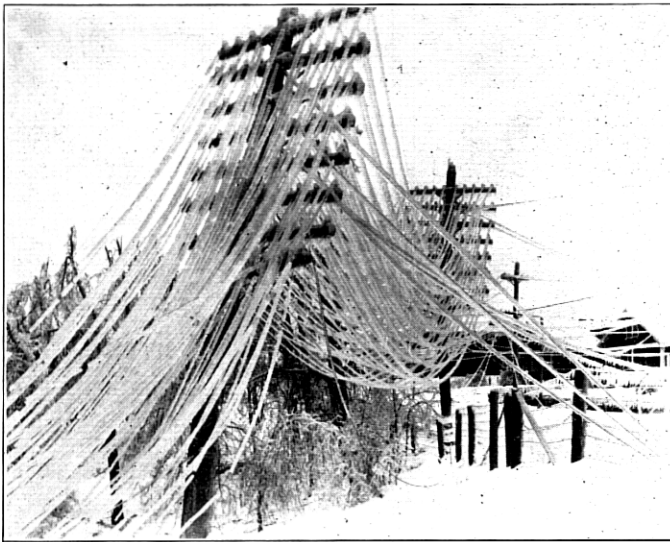

Fig. 4—Section of New York-Boston Main Line Showing Wires Heavily Loaded with Ice. November 28, 1921

and of the methods available for providing long-distance telephone facilities, which in general are aerial wire and cable, it has been decided that for relief in these sections the cable method will give the best and most economical results. Long underground cables, as is well-known, have been in operation for many years between Boston, New York, Philadelphia, Baltimore and Washington, Chicago and Milwaukee and in other sections. However, the type of cable and associated apparatus which is now being used in the development of the more comprehensive plan is quite different from that originally used between Boston and Washington and in the other sections, particularly in the use of copper conductors of a smaller gage combined with improved loading coils, the vacuum tube telephone repeater

and other methods and apparatus which are the result of recent developments. Lead-covered aerial cable supported on wooden pole lines is to be used in general on all of the routes except in the two sections just mentioned and through cities or where special conditions exist for short distances. The possibility of now using conductors of No. 16 and No. 19 A. W. G. instead of conductors up to

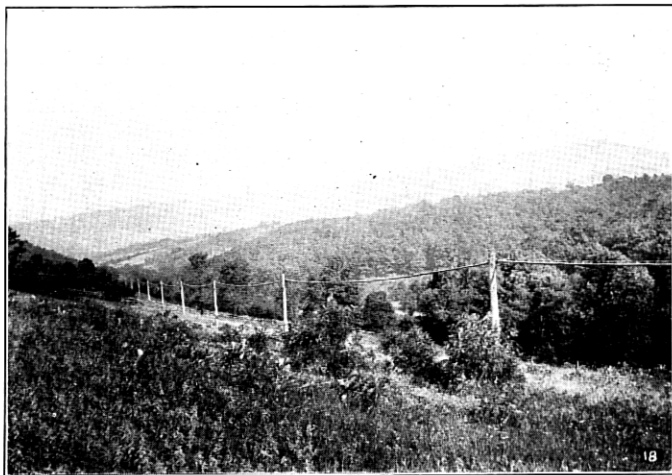

Fig. 5—General View of Pole Line Carrying Aerial Cable

No. 10 A. W. G. as in the older cables, has contributed to make aerial construction rather than underground conduit the more economical in many sections, as one cable will provide for a much greater number of circuits and consequently fewer cables will be required.

#### LINE CONSTRUCTION

The general type of aerial construction which was used for over 250 miles of the total distance of 302 miles from Philadelphia to Pittsburgh may be seen from Figs. 5 and 6 which illustrate the poles, steel suspension strand, metal supporting rings and the cable. The poles are 25-foot untreated chestnut spaced 100 feet apart and designed to carry additional cables in the future. While the poles are new and carry only one cable they have a factor of safety of about 9 under the most severe storm conditions expected, but this will, of course, be reduced as other cables are placed and will gradually be decreased on account of decay at the ground line until it becomes necessary to start replacing the poles. Many of these poles were grown near the locations where they now stand. In other sections, it is planned

to use butt-treated chestnut or cedar poles, or creosoted pine poles where these prove to be the more economical.

The galvanized steel suspension strand has a breaking strength of about 16,000 pounds and the actual tension under normal conditions is about 7,000 pounds. In placing the strand, it is necessary to pull it to just the right tension in order that when the cable is hung it will have the proper sag. The correct tension is readily determined by what is known as the "oscillation" method. The metal rings are spaced 16 inches apart and the cable weighs about  $7\frac{1}{2}$  pounds per foot.

The size and make-up of the cable vary somewhat with the number of circuits of the various types that are to be provided in the different sections, but in general it is full size, that is, its over-all diameter is

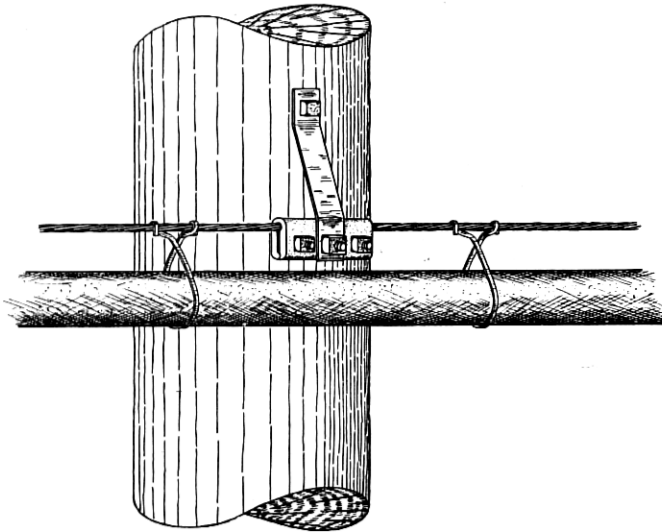

Fig. 6—Method of Supporting Aerial Cable and Messenger

$2\frac{5}{8}$  in. which is about the maximum size of telephone cable. The sheath is of lead-antimony alloy, one-eighth of an inch thick, and under normal conditions it is, of course, air-tight to keep moisture from entering. The cable for the aerial section was received from the factory in 500-foot lengths, this being largely determined by the arrangement necessary to permit the proper installation tests.

#### ROUTE

We might next consider the route selected and for this purpose Fig. 2 will again be helpful. It will be noted that starting at Phila-



delphia, the cable is routed to Reading touching Pottstown, Phoenixville and other points. From Reading to Harrisburg the cable follows closely the William Penn Highway, although in sections it was necessary to obtain private right-of-way or to use longer routes removed from this highway on account of the lines of various kinds already in operation there. It is very desirable for economic reasons to keep the length of these cables as short as possible and in some cases this is absolutely necessary to obtain proper operating conditions.

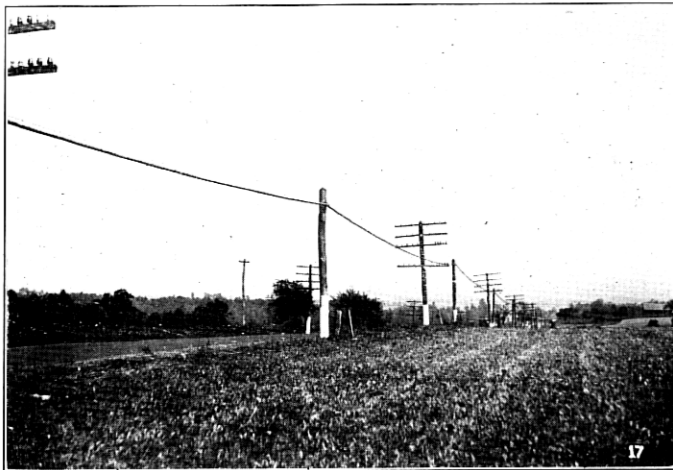

Fig. 7—Cable Line on Seven-Mile Stretch of Lincoln Highway. Aerial wire line to be dismantled later.

However, the most direct routes cannot always be used, for many obvious reasons, and this problem required careful consideration in all sections of the cable.

Between Harrisburg and Pittsburgh the Allegheny Mountains had to be crossed and for this crossing only two general routes were found practicable, the first following an existing pole line which is the New York-Chicago telephone line through Lewiston, Altoona, etc., and which we may call the northern route, and second a southern route through Shippensburg, Bedford and Ligonier for the most part along the Philadelphia-Chicago line and also the Lincoln Highway. A middle route which is now used for the Harrisburg-Pittsburgh line was not seriously considered as the country was too rough for economical construction and maintenance and no important advantages were to be obtained. After careful surveys and cost studies, taking into account all existing and anticipated conditions, such as circuit

requirements and towns to be reached, length of practicable routes, maintenance conditions, freedom from probable physical and electrical interference, etc., it was decided to build on the southern route.

This route, while of nearly the same length as the northern one and offering some important advantages, was not free from difficulties as it crosses the Allegheny Mountains within a few miles of the highest

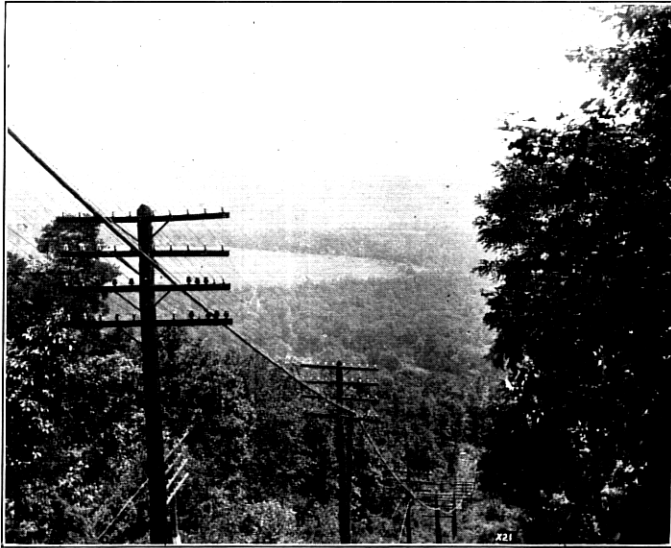

Fig. 8—Cable Line Across Valley at Grand View

point. Fig. 7 shows the cable line on what is known as the seven-mile stretch of the Lincoln Highway east of Ligonier, and here the going was fairly good. The Philadelphia-Chicago aerial wire line is also shown and two of the crossarms carrying 10 wires each are to be removed in the near future and the circuits operated in the cable. It is planned to remove the remaining two crossarms later on. Fig. 8 shows the cable across a valley and is taken from the point on the Lincoln Highway called Grand View. Fig. 9 shows the crossing of the Juniata River east of Bedford where special construction was used. Fig. 10 shows just one example of the conditions encountered in crossing the many mountains and a photograph does not do the scenery or the construction difficulties justice. On account of the steep slopes, clamps are used at many points to fasten the cable to the strand.

Narrow-gage timber railroads were used in the mountains where possible to get material to the job and Fig. 11 shows one of the regular

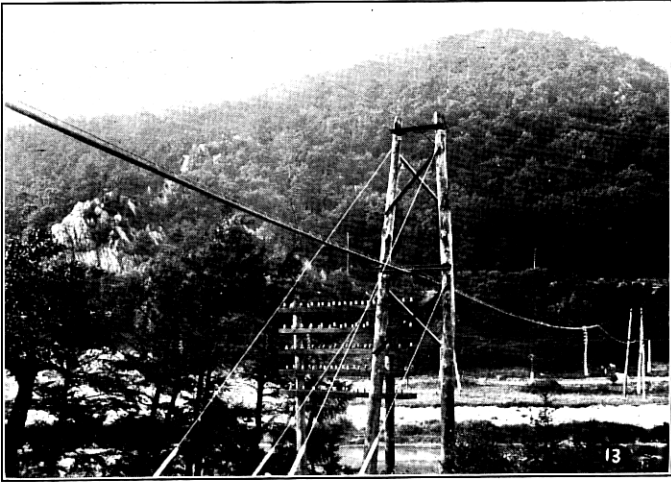

Fig. 9—Cable Crossing at Juniata River

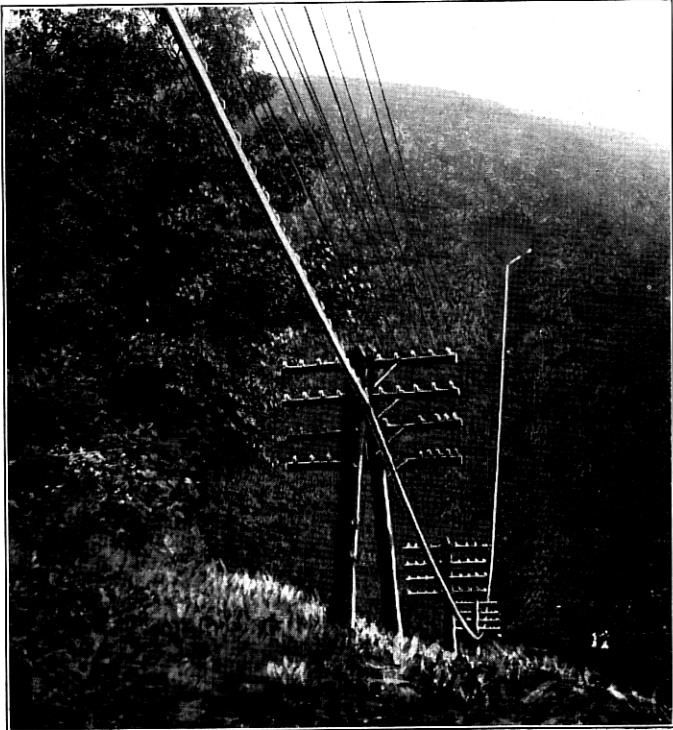

Fig. 10—Cable Line on Steep Slopes

flat cars adapted for our purpose. Fig. 12 shows two 5-ton tractors in action on top of one of the mountains. As many sections of the country are very rough and highways several miles distant it seemed that no other method of transporting the cable reels, which weigh



Fig. 11—Narrow-Gage Mountain Railroad and Flat Car



Fig. 12—Tractors Placing Cable Reels in Rough Country

nearly 5,000 pounds, could possibly be used, and certainly no other means would have been as satisfactory. Even with these methods the cable reels could not always be delivered where desired and in some cases it was necessary to pull the sections of cable through the rings for a distance of nearly a mile to get them in place.

## CABLE MAKE-UP

As stated before, the make-up of the cable varies somewhat with the circuit requirements in the different sections but the wires and arrangement in a typical section of cable are roughly illustrated in Fig. 13.

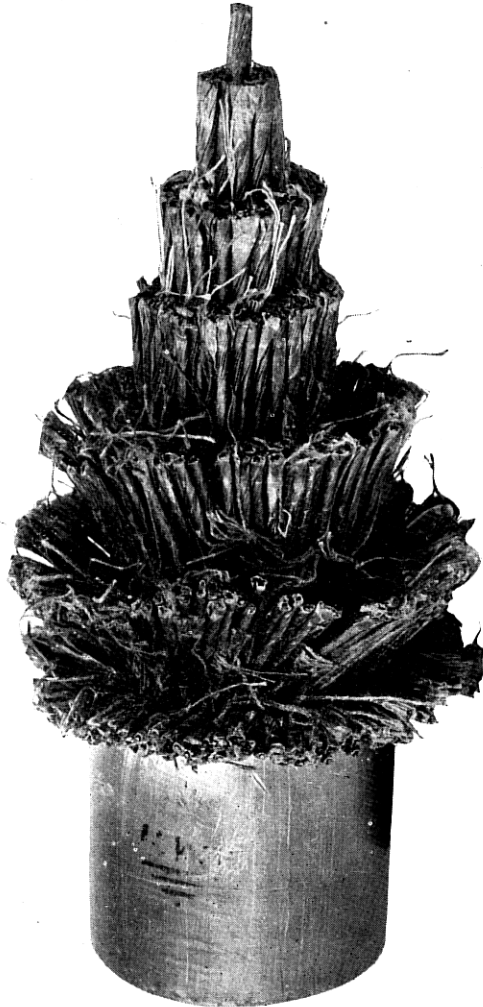

Fig. 13 Piece of Cable with Sheath Partly Removed

The cable is of quadded construction, that is, the wires are first wrapped with dry paper for insulation and twisted into pairs and then two pairs are twisted into what is called a quad. These quads are

arranged in concentric layers as shown and great care and skill are required in the design and manufacture or there is certain to be serious cross-talk between the several hundred circuits when used for long-distance service. Even after the application of the best present manufacturing methods, tests are made on all circuits at three points in each loading section of 6000 feet while the cable is being spliced. These tests are made in order to determine the best possible arrange-

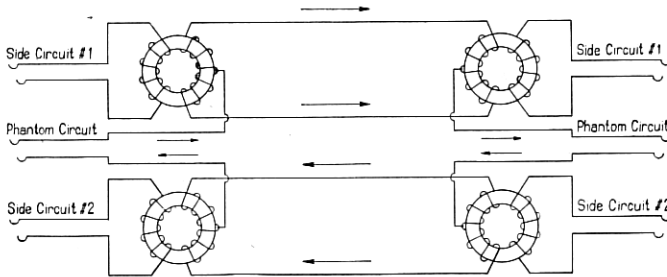

Fig. 14—General Phantom Circuit Arrangement. Four wires providing three circuits

ment of conductors for still further reducing cross-talk between circuits, and the splicing is done accordingly.

There are 19 quads of No. 16 A. W. G. and 120 quads of No. 19 A. W. G. pure copper conductors in one of the principal sections, and the arrangement of the four wires in each quad is such that two physical circuits and one phantom circuit are made available. The method of obtaining three telephone circuits from two pairs of wires is old and extensively used. It is illustrated in Fig. 14. The method results in a 50 per cent increase in the number of available circuits and its application to this project is therefore of very great economic importance. Now the total of 139 quads multiplied by 3 gives 417 circuits or as many as could be carried on about 14 heavily loaded pole lines if aerial wire were used, but as will be described later, we will have to use two of these circuits to make one telephone circuit in some cases where the distances are comparatively great, so it is expected that only about 300 telephone circuits will be obtained for regular service. This is as many as could be carried on 10 heavily loaded pole lines if aerial wire were used. It is now thought that in some sections this number of circuits will take care of future demands for about 10 years after allowing for the dismantling of some existing aerial wire.

As these cables can be obtained in any size desired up to the maximum, the period for which they should be engineered can be determined from studies of circuit requirements and costs. These studies are of very great importance and the cost considerations include, of course,

annual costs of the various plans over proper periods as well as first costs.

#### LOADING

Loading coils are now connected to many of the circuits and all of the circuits in this cable are intended to be equipped with coils located at 6000-foot intervals. The theory and practice of loading are described in papers previously presented before the Institute<sup>1</sup> and for our purpose it will be sufficient to state that these loading coils very materially reduce the attenuation losses and improve the quality of transmission as compared to cable circuits not so equipped. The improvement in so far as the attenuation losses are concerned, varies with the type of circuit and loading coils, but with one of the No. 19

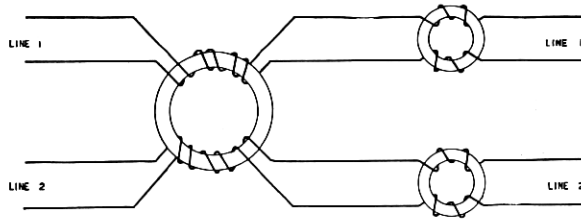

Fig. 15.—Loading Coils Connected to a Group of Four Wires and Arranged for Phantom Operation

A. W. G. circuits in this cable loaded with coils having an inductance of 0.175 henry located at 6000-ft. intervals, the losses are only about one-third as great as in a similar circuit without the coils. The connections and arrangements of the coils are shown in Fig. 15 and it will be noted that coils have been connected to both the physical and phantom circuits. The arrangement is such that there is no appreciable interference between circuits due to magnetic action in the iron cores of the different coils or to the necessarily close electrical relation in the windings.

The loading coils are potted and sealed in iron pots, two of which are shown in Fig. 16, and in the country these are mounted on pole fixtures. Each pot contains 36 groups of 3 coils each. The pots are nearly 30 inches in diameter at the flange, 52 inches high and weigh about 2700 pounds. The pots can be obtained in different sizes depending upon the number of coils which it is desired to install at one time. When the cable was installed, extra lead sleeves were

<sup>1</sup>Papers by M. I. Pupin, Transactions of A. I. E. E., XVII, May 1900 and XV, March 1899.

Paper by Bancroft Gherardi, Transactions of A. I. E. E., XXX, June 1911.

placed at the loading points and a little slack left in the wire to facilitate the connection of four additional loading pots to the cable at

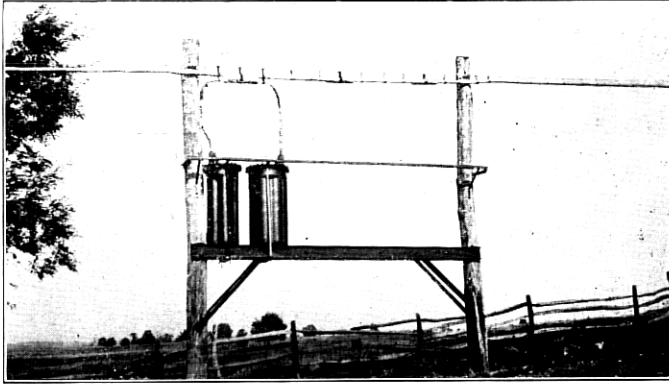

Fig. 16—Loading Fixture

some later date when the circuits are needed. The loading points must be uniformly spaced in order to obtain the proper impedance characteristics in the circuits as will be referred to later. Fig. 17 shows the iron core of a loading coil and Fig. 18 shows this core



Fig. 17—Loading Coil Core



Fig. 18—Loading Coil with Winding Completed

wound with insulated wire and then wrapped with cloth and the terminals brought out nearly ready for potting. Fig. 19 shows several



coils arranged on one of the spindles which will be placed in the iron pot also shown. This particular pot will hold 7 spindles and when they are in place, the pot will be filled with compound and thoroughly sealed.

#### TELEPHONE REPEATERS

Even with the improvement in the quality of transmission and reduced attenuation losses effected by the use of loading coils, loaded

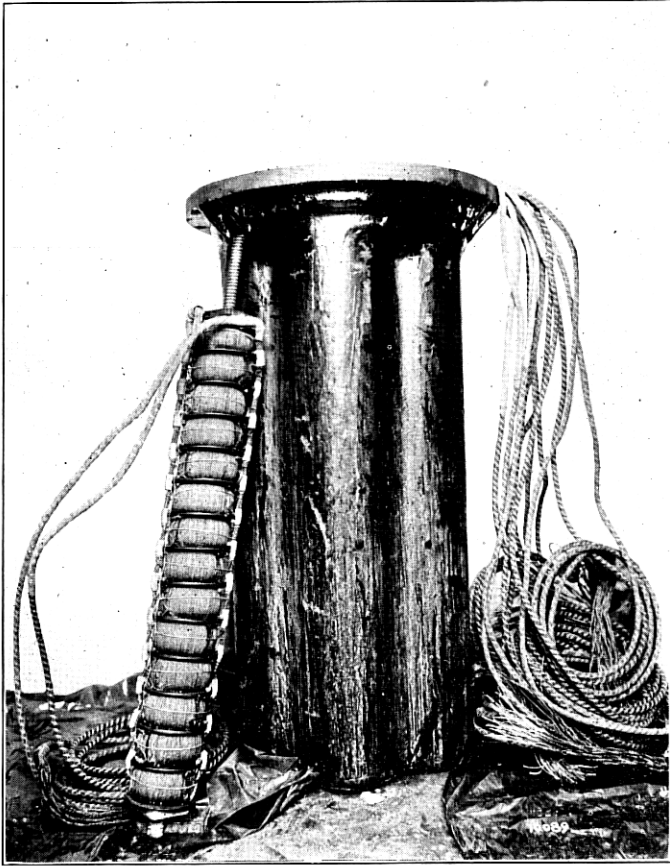

Fig. 19—Loading Coils on Spindle, Iron Loading Coil Case and Spindle Cables

cable circuits alone of No. 16 and No. 19 A. W. G. could be satisfactorily operated for distances less than 100 and 60 miles, respectively, and this is far short of our requirements in this case. In fact, we wish to operate some telephone circuits on these conductors and through this cable and future cables up to at least 1000 miles in length. This

can be accomplished by the use of telephone repeaters connected to the loaded conductors.

Telephone repeaters have been developed to a high state of perfection and are completely described in a paper presented by Messrs. Bancroft Gherardi and Frank B. Jewett at a joint meeting of the A. I. E. E. and the Institute of Radio Engineers in New York, October 1, 1919. Briefly, the purpose of a telephone repeater is to receive small telephone currents, amplify them and send them on, preserving

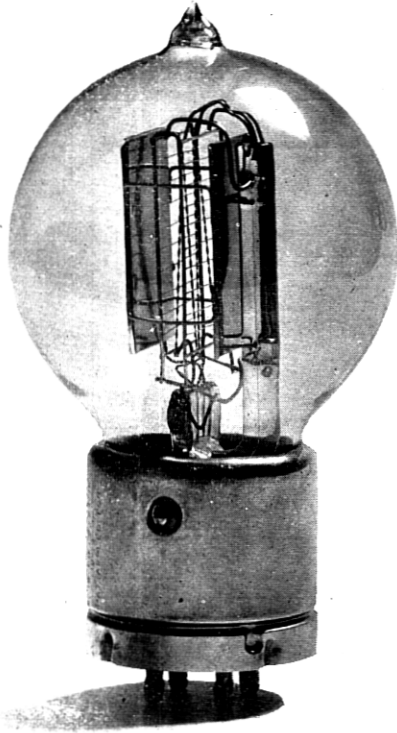

Fig. 20—Vacuum Tube

all the while the original wave shape. Therefore, if one or more telephone repeaters are properly inserted in circuits adapted to their use, the range of satisfactory transmission can be greatly extended. As many hundreds of vacuum-tube repeaters are in operation on the Philadelphia-Pittsburgh cable and connected cables, and as a great many more are planned for future installation, we will briefly consider the elementary features of some of the types of repeaters used.

Fig. 20 shows the structure of the vacuum tube which is an essential

element of this type of repeater. It is a small glass bulb with a vacuum that is as good as is practicable to obtain. In the tube is a filament which is heated to incandescence during operation,

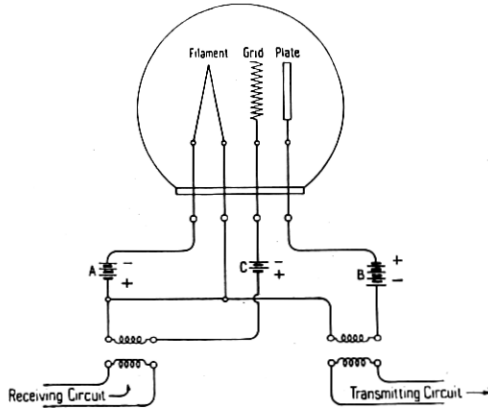

Fig. 21—Vacuum-Tube Repeater Element

and a grid and plate. The circuits directly associated with the tube are shown in more detail in Fig. 21, and this would constitute a device for amplifying currents from one direction. As is well understood, any change in the potential impressed on the grid causes a change in the current flowing in the plate-filament circuit. To obtain complete two-way repeater action two of these amplifier arrangements are combined with the circuits shown in Fig. 22.

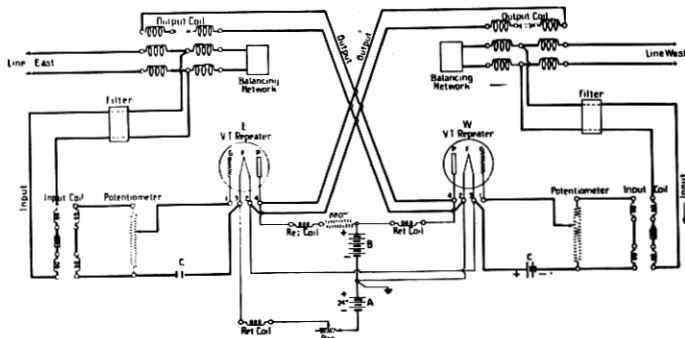

Fig. 22—Two-Way Vacuum-Tube Repeater Circuit

It will be noted that the line circuit from one direction, for instance, the one designated "line west," is connected through a three-winding transformer to a balancing network which is so made up as to balance

the line as nearly as possible at telephone frequencies. This balance is essential to proper repeater operation. The circuit arrangement is such that part of the incoming energy is diverted to that part of the circuit containing the input coil directly associated with this three-winding transformer. By the action of the vacuum-tube arrangement amplified energy is transmitted to the line east. That part of the original incoming energy from the line west that goes through the balancing network or the output coil is not, of course, transmitted along into the line east. The operation in the case of currents incoming from the line east is similar and it will be noted that the complete repeater circuit is made up of two symmetrical parts. This circuit arrangement constitutes what is known as a two-wire repeater and the apparatus is, of course, all closely associated in the same office.

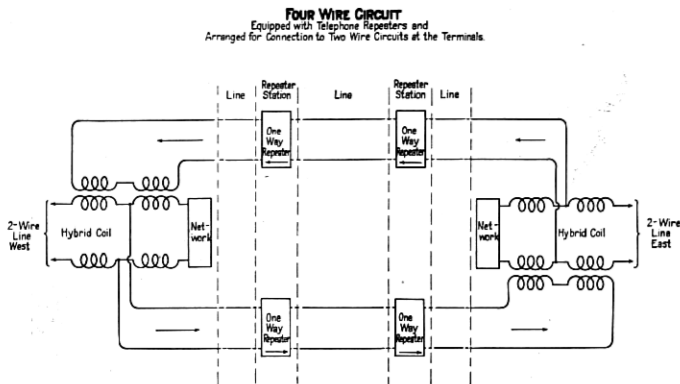

Fig. 23—Four-Wire Circuit equipped with telephone repeaters and arranged for connection to two wire-circuits at the terminals

Several of these repeaters may be inserted in tandem at appropriate points in a circuit, but there is a limit to the length of circuit that can be satisfactorily operated with this arrangement, this length depending upon the type of the facilities used. When longer circuits are required, a four-wire arrangement is used, as shown in Fig. 23. It will be noted that in this arrangement the three-winding transformers are not located in the same office but may be in offices several hundred miles apart. At each of the intermediate stations a vacuum-tube amplifier arranged for amplification in one direction only is connected to each of the two branches of the circuit. Two circuits are, of course, required between the terminals and these may be either physical or phantom circuits.

An advantage of this arrangement is that balancing networks are

not required at each repeater station and the general matter of balance and consequently good repeater operation in the circuit as a whole is greatly simplified. This arrangement can, therefore, be satisfactorily used for long circuits where two-wire operation might be impracticable,

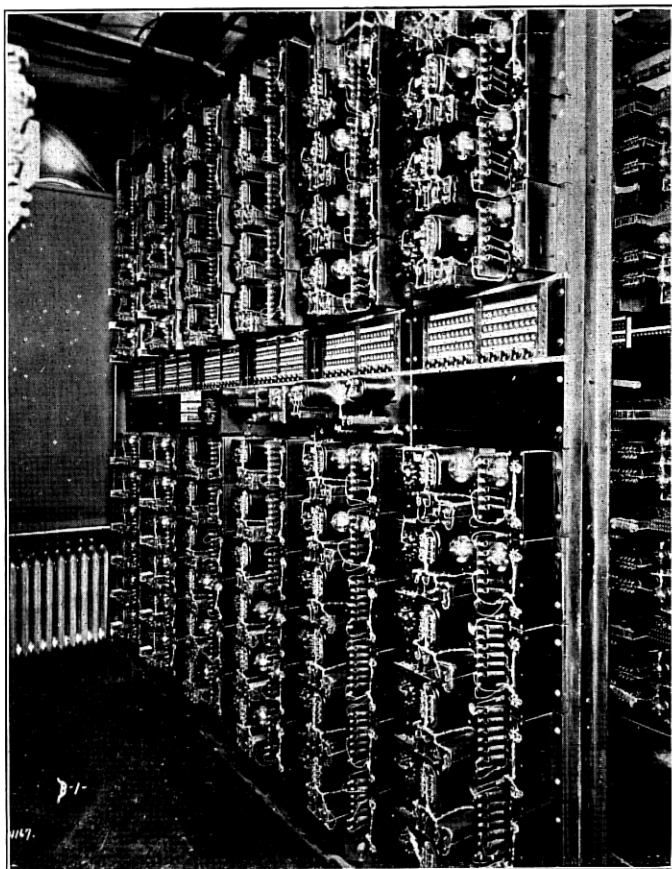

Fig. 24—Group of Repeaters at Reading, Pa.

and examples would be such circuits as New York-Pittsburgh or New York-Chicago.

Both of these types of circuits may be operated on No. 19 A. W. G. four-wire facilities which may be either physical or phantom circuits.

Fig. 24 shows a group of repeaters installed in the office at Reading, Pa., and Fig. 25 shows one of the four-wire repeater units in somewhat greater detail.

LINE IMPEDANCE

In order that networks may be used to balance the lines for repeater operation, it is necessary as a practical proposition that the impedance characteristics of the lines be fairly uniform over the range of telephone frequencies. The solid line in Fig. 26 shows the resistance component of the impedance of a No. 19 loaded cable circuit with all loading coils in place. The solid line in Fig. 27 shows the

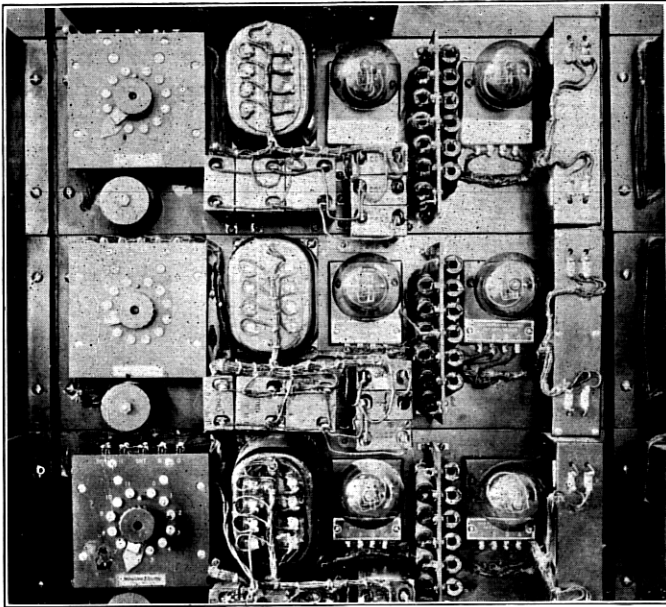

Fig. 25—Assembly of Four-Wire Repeater Apparatus

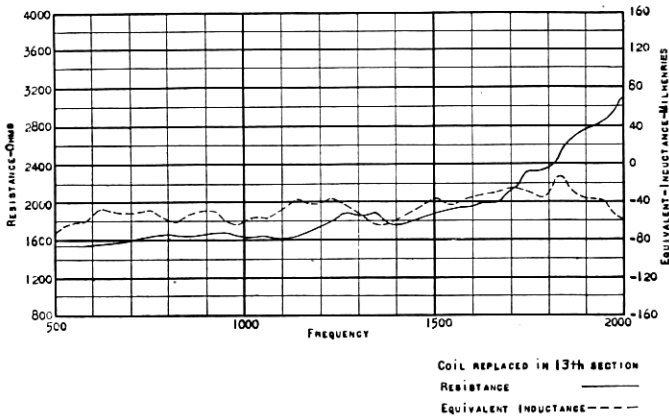

Fig. 26—Line Characteristics—A Cable Circuit in Normal Condition

resistance component found in impedance measurements on the same circuit with one coil omitted at the thirteenth loading point from the end at which the tests were made. It will be noted that in the latter case the characteristics of the circuits vary greatly with frequency. It would therefore be very difficult as a practical proposition to build up a network that would balance lines in this condition, and such variations in the electrical characteristics of a circuit impair the quality of telephone transmission, as the currents of different frequencies are differently affected. The necessity for careful maintenance work in promptly replacing loading coils which may become defective or preventing other irregularities from creeping into the plant will therefore be clear.

### TRANSMISSION REGULATION

The resistance of small-gage cable conductors is one of the important factors that determine the transmission losses of a circuit. The resistance of a No. 19 A. W. G. pair is about 88 ohms per mile so that

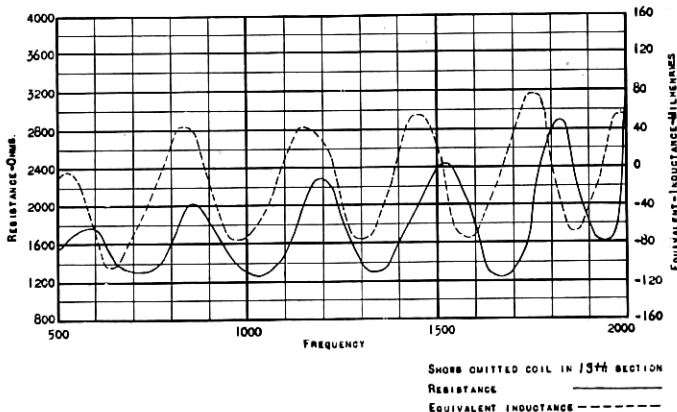

Fig. 27—Cable Circuit with Loading Coil Missing at Thirteenth Loading Point from Terminal

in a long circuit this factor of line resistance reaches considerable proportions. Now as most of the cable is aerial, the resistance of the conductors is of course affected by changes in temperature both daily and seasonal and the transmission losses vary accordingly. These changes in transmission values are of such magnitude that automatic transmission regulators are being provided for certain groups of longer circuits. All changes in the transmission equivalents of the circuits from whatever causes must be carefully watched and necessary adjustments made or the service will be seriously affected.

## TELEGRAPH

In the section between Philadelphia and Pittsburgh practically all of the existing long aerial wire circuits are composited, that is, they are arranged for simultaneous telephone and telegraph operation. The telegraph circuits thus obtained are generally used in furnishing what is sometimes called "leased wire" service. The ground return system providing either full duplex or single-line operation is used and the line currents average about 75 milliamperes. This grounded telegraph system cannot be used where simultaneous telephone and telegraph service is desired on loaded cable circuits of the length involved in this cable, and as a part of the work of carrying out the comprehensive toll cable plans of the Bell system, a new telegraph system had to be developed. It was found preferable to use a metallic return circuit and to limit the line current to a value between 3 and 5 milliamperes in order to prevent serious interference to the telephone circuits due to the "flutter effect,"<sup>2</sup> Morse thump, and mutual interference between telegraph circuits. Morse thump results when the composite sets, that is, the apparatus used for separating the telephone and telegraph currents, do not completely prevent the latter from entering the telephone circuit, thus causing interference. The telegraph repeaters are located at about 100-mile intervals on the No. 19 circuits and at somewhat less frequent intervals on No. 16 circuits. The telegraph apparatus is of course located in the same buildings that are used to house the telephone repeaters, and on the Philadelphia-Pittsburgh cable telegraph repeaters will be located initially at Philadelphia, Harrisburg, Bedford and Pittsburgh.

## TEST BOARDS

All of the conductors in the cables are carried into stations located at about 50-mile intervals and apparatus is provided in these stations for making regular tests to ascertain the condition of the cable and to locate trouble quickly. At these offices the different kinds of operating apparatus are also connected to the cable conductors; examples of this apparatus are phantom repeating coils, composite sets to permit simultaneous telephone and telegraph operation, telegraph repeaters, telephone repeaters and associated balancing equipment, signaling apparatus, and where required, the switchboards necessary for making the telephone connections involved in furnishing service. It is necessary that this apparatus which is installed in large quantities

<sup>2</sup>Paper by Martin and Fondiller in JOURNAL OF A. I. E. E., February, 1921.



be systematically arranged and facilities provided for making quick changes in the circuit arrangement. The circuits are wired through jacks installed in groups in test boards for this purpose and to facilitate testing. One of these boards is illustrated in Fig. 28. This particular board is located in one of the larger offices. The test boards in one of the repeater stations, such as Bedford, would consist of a smaller

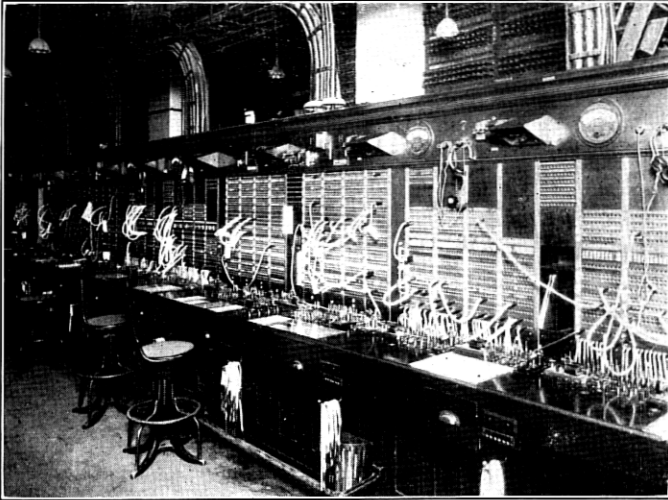

Fig. 28—Test Boards

number of positions. A position is three feet in length. In Fig. 28 each position bears a number.

#### STATIONS AND POWER PLANTS

Telephone repeaters of either the two-wire or four-wire type are connected to the circuits at approximate intervals of either 50 or 100 miles, depending upon the type of facilities which it is economical to use in the different circuits and the kind of service for which a given circuit is intended. As mentioned above, telegraph repeaters are installed at about 100-mile intervals. At some of these points existing offices are used while in a number of cases it was necessary to erect buildings for the sole purpose of housing the repeaters, testing apparatus and other equipment associated with the cable. For example, new buildings of fire-proof construction were erected at Shippensburg, Bedford and Ligonier. Fig. 29 is a view of the building at the latter point and the other two buildings are similar to this one, the dimensions being about 50 by 80 feet. Power plants are installed in these build-

ings to furnish current of the proper characteristics for operating the apparatus, and storage batteries are provided to insure uninterrupted service. As an indication of the size of these plants the 24-volt storage batteries installed for the initial load at Bedford have a capacity of 2240 ampere-hours and this provides about one day's reserve. The capacity can, of course, be increased as repeaters are added from time to time when additional circuits are needed. Storage batteries of smaller sizes supplying current at potentials of 30, 120 and 130 volts are also provided.

#### EXAMPLES OF CIRCUIT ARRANGEMENTS

Fig. 30 shows two possible methods of building up a Philadelphia-Pittsburgh terminal circuit and Fig. 31, a method of building up a New York-Pittsburgh terminal circuit. In all three cases these telephone circuits are intended to have a transmission equivalent of about 12 miles of standard cable. Some Philadelphia-Pittsburgh

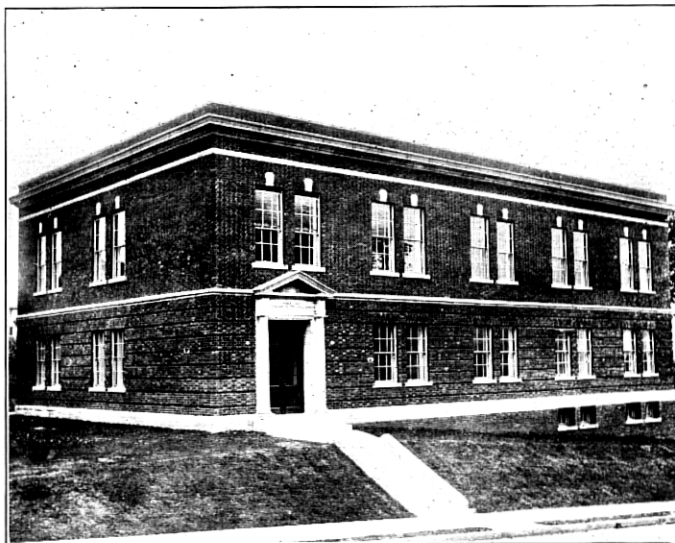

Fig. 29—Test and Repeater Station at Ligonier, Pa.

terminal circuits of the first type have been in everyday operation for several months, but it is not the most economical arrangement that it is possible to obtain for general use in providing this or similar service. It will be noted that No. 19 four-wire facilities are used between Philadelphia and Harrisburg and four-wire repeaters are located at these two points. At Harrisburg the four-wire circuit is

connected to a No. 16 two-wire circuit with a two-wire repeater at Bedford. This arrangement was used in order to start service through the cable with the facilities available, but it is intended later on to use the arrangement shown in example No. 2.

In example No. 2, No. 16 heavily loaded conductors are used and two-wire repeaters are located at Reading, Shippensburg and Ligonier. The total transmission equivalent of this circuit without repeaters is

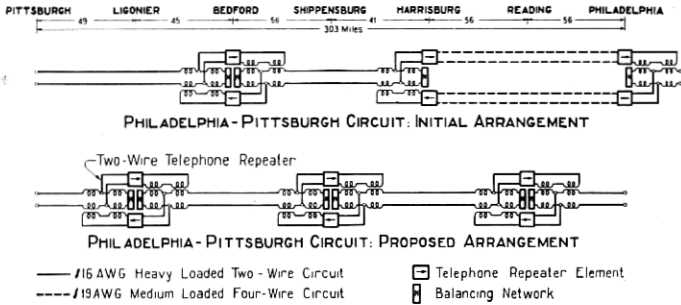

Fig. 30—Cable Circuit Arrangements

about 50 miles of standard cable so that in order to obtain a net equivalent of 12 miles for the circuit each of the three repeaters must give a transmission gain of nearly 13 miles of standard cable. This circuit could not of course be used for telephone purposes without repeaters.

The third example shows how it is expected to operate New York-Pittsburgh circuits intended for business between these two terminals.

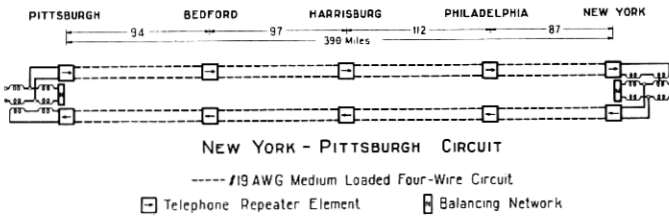

Fig. 31—Cable Circuit Arrangements

Four-wire No. 19 loaded cable facilities are used with four-wire telephone repeaters located at New York, Philadelphia, Harrisburg, Bedford and Pittsburgh.

Even with conductors of only two gages in the cable, it is clear that many different combinations of facilities can be built up into telephone circuits and an endeavor is always made to use the most eco-

nomical arrangement that will furnish the service required over each circuit group. The examples described above are of circuits used for business between the terminals indicated and if these circuits were to be connected to others extending to points considerable distances beyond these terminals different arrangements would be required. The cable conductors used in building up these telephone circuits can be composited and telegraph circuits are thus provided for simultaneous operation with the telephone circuits.

#### CONCLUSION

In the above discussion, an effort has been made to furnish some descriptive information regarding a complete cable system recently completed and now in successful operation between Philadelphia and Pittsburgh and designed for long-distance telephone and telegraph service. In one sense this discussion may be considered a report of the present status of the toll cable plant intended to connect Atlantic Seaboard cities with Chicago and other cities, and extensions are now under construction. However, most of the general methods which it is planned to use in these extensions are not expected to differ greatly from those described.

This cable system utilizes many new developments in the communication art and some of these, which have been briefly touched on here on account of their important application, have been described in more detail in previous papers. It is expected that more information regarding other specific developments which have contributed in an important way to the successful carrying out of this project or which may be utilized later on will be furnished in future papers.

An important feature of this cable project is the fact that while many new developments and practices are utilized, the design of the system as a whole is such as to fit in economically with existing wire and cable systems and proposed extensions.