

The Relation of the Petersen System of Grounding Power Networks to Inductive Effects in Neighboring Communication Circuits

By H. M. TRUEBLOOD

THE purpose of this paper is to present a simple theoretical treatment of those features of the Petersen method of grounding a power network which are of principal interest from the standpoint of inductive effects in neighboring communication circuits. In this method, the neutral of the system is grounded through an inductance which is in resonance, at the fundamental frequency, with the total direct capacity of the system to ground. The theory of the behavior of a power system thus grounded at times of accidental faults to earth has been developed by Petersen in a paper published in 1919,¹ in which the results of field tests and of operating experience with an installation in Germany are also described. The method has also found application in other places in Europe, chiefly in Italy and Switzerland. It does not appear in any of these cases that inductive interference was a factor requiring, or at any rate receiving, consideration. In fact, it does not seem that either Petersen himself, or other engineers in Europe who have made use of his scheme, have considered it except as a method of protecting power systems from the effects of accidental grounds.

The features of the method that are of interest from the viewpoint of inductive interference relate both to normal operating conditions of the power system and to the phenomena which occur when a phase of the system is grounded. With regard to the former, it is principally, though not entirely, the effect of the neutral reactor on the harmonics of frequencies within the voice range that require examination; with respect to the latter, the things of chief, though not exclusive, importance, are the ground currents and unbalanced voltages to ground of fundamental frequency, which are possible sources of disturbance in exposed communication circuits.

These features, particularly those concerned with effects at fundamental frequency, are more or less closely related to questions of primary importance from the standpoint of power system operation. It is impossible that this should not be the case. Accidental disturbances of a character which may interrupt service or endanger apparatus or equipment in a power system may produce inductive

¹ W. Petersen, *Elektrotechnische Zeitschrift*, 40, pp. 5-7 and 17-19, 1919; *Sci. Abs. B*, Nov. 29, 1919.

disturbances in neighboring communication circuits, and the question of grounding the neutral, in whatever manner, or of leaving it isolated, exists because of its bearing on the avoidance or limitation of such power system disturbances. Thus a method of grounding the neutral, or any other method of power system operation designed to limit the extent or the severity of accidental disturbances, must necessarily possess importance with respect to inductive effects in exposed communication circuits.

It does not seem necessary, therefore, to apologize for the discussion, in the first section of the paper, of the behavior of the power system at times of faults to earth. In this section, an explanation is given of the principal characteristic effect of the reactor which differs in some respects from that set forth by Petersen in the paper already referred to. The matter of transient over-voltage on a non-grounded phase is also examined in this section, and the bearing of these and the earlier considerations on inductive effects is discussed.

In the second section of the paper, the behavior of the power system with reactor under normal operating conditions is discussed with reference to noise and other inductive effects in neighboring communication circuits.

1. EFFECTS WITH A GROUNDED PHASE ON THE POWER SYSTEM

1. Action of Coil in Suppressing Arcs to Ground

Referring to Fig. 1, in which, and in the following discussion it is assumed that the three admittances to ground are equal, the admittance current through the fault from the two sound phases is

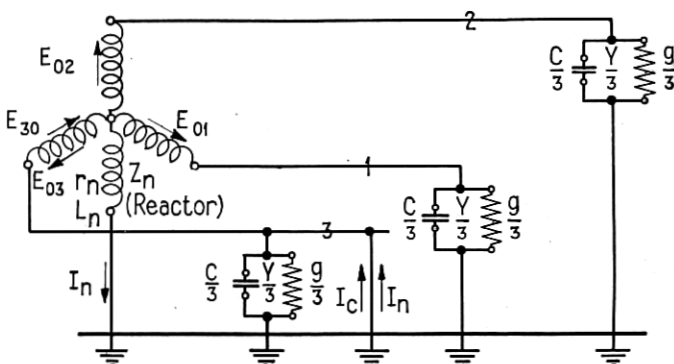

Fig. 1—Single-Phase System with Neutral Grounded Through Reactor. Admittances to Ground Assumed Balanced

$$\begin{aligned}
 I_c &= \frac{Y}{3}(E_{01} - E_{03}) + \frac{Y}{3}(E_{02} - E_{03}) = \frac{Y}{3}(E_{01} + E_{02} - 2E_{03}), \\
 &= Y E_{30} = (g + jC\omega) E_{30}.
 \end{aligned} \tag{1}$$

The current through the coil and fault is

$$I_n = \frac{E_{30}}{Z_n} = \frac{E_{30}}{r_n^2 + \omega^2 L_n^2} (r_n - j\omega L_n),$$

or, neglecting $\frac{r_n^2}{\omega^2 L_n^2}$ in comparison with unity,

$$I_n = \frac{E_{30}}{\omega^2 L_n^2} (r_n - j\omega L_n).$$

Thus the total fault current is

$$I_c + I_n = I_f = E_{30} \left[g + \frac{r_n}{\omega^2 L_n^2} + j \left(\omega C - \frac{1}{\omega L_n} \right) \right],$$

and, if the coil is adjusted for resonance,

$$\begin{aligned}
 I_f &= E_{30} \left(g + \frac{r_n}{\omega^2 L_n^2} \right), \\
 &= \frac{E_{30}}{\omega L_n} \left(\frac{r_n}{\omega L_n} + \frac{g}{\omega C} \right).
 \end{aligned} \tag{2}$$

On comparison of this expression with the above equation (1) for the charging current, which constitutes the fault current if the system is isolated, it is seen that, if the losses in the system are small, the effect of the coil is to reduce the magnitude of the current in the fault approximately in the ratio of $\left(\frac{r_n}{\omega^2 L_n^2} + g \right)$ to $|Y|$, *i.e.*, neglecting terms of the second and higher orders, in the ratio $\left(\frac{r_n}{\omega L_n} + \frac{g}{\omega C} \right)$ to unity. Further, as equation (2) shows, the phase of the fault current coincides with that of the voltage impressed between the faulty wire and ground to the degree of approximation here used, *i.e.*, to the second order of small quantities. (The bracket on the right-hand side of (2), if written in full, would include quadrature terms in the square and higher even powers of $r_n/\omega L_n$.) With the system isolated, the phase displacement is nearly 90° .

The action of the coil may be described as a transfer of the charging current from the fault to the coil, leaving nothing but the component of current to supply losses at the fault. With suitable design of the coil, this energy current can be made small.

The coincidence in phase of the fault current and the voltage impressed by the transformer on the faulty wire, together with the small magnitude of the former, are very favorable to the suppression of the

arc. Following its extinction, there is a further action of the resonant system consisting of the coil and the total capacity to ground which acts in such a way as to prevent any over-voltage and to restore the normal potentials to ground *gradually*, thus tending to prevent the arc from restriking. This action is as follows:

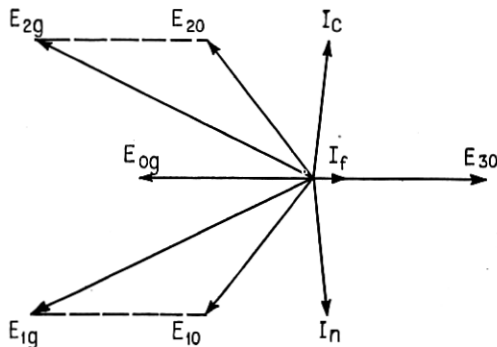

Fig. 2—Vector Diagram Showing Relations of Voltages and Currents at and Following Extinction of Arc

Referring to Fig. 2, the vectors E_{10} , E_{20} , E_{30} represent the emfs. impressed between lines and neutral by the transformer bank. I_c , I_n , I_f are respectively the admittance current to the fault, the current supplied by the reactor to the fault, and the total fault current. The fault is assumed to be on phase 3. The arc will go out when I_f passes through zero. At this instant, E_{30} is also zero and I_n and I_c have nearly their maximum values. Their instantaneous values are, however, exactly equal and opposite in the sense indicated by the arrows in Fig. 1, *i.e.*, regarded as currents fed to the fault by the two parallel circuits (1) coil-fault-faulty wire- E_{30} and (2) admittance of sound phases-fault-faulty wire-transformer bank. These instantaneous currents are exactly equal in magnitude and are in the same direction in the single series circuit consisting of coil, transformers, admittance to ground of the three phases in parallel, and ground. Thus the condition in this series resonant circuit at the instant of extinction is that of an established free oscillation, the energy of the oscillation being at this instant wholly electromagnetic.

The voltage across the reactor due to the current I_n , in the direction of E_{30} (Fig. 1) is represented in Fig. 2 by the vector E_{0g} . This is 180° out of phase with E_{30} and initially of the same amplitude. At the instant the arc goes out, both are practically zero. As the oscillation progresses, E_{0g} dies away, due to damping, and the resultant

voltage of the faulty wire to ground, viz., $E_{2g} = E_{30} + E_{0g}$, passes gradually back to the normal value E_{30} . At the same time the voltages to ground of the two sound phases (E_{1g}, E_{2g}) return to their normal values E_{10}, E_{20} . The ends of the three vectors, E_{3g}, E_{1g}, E_{2g} , may be thought of as sliding at equal rates along the line E_{30} and the dotted lines parallel to it.

The effectiveness of the action just sketched (it has been assumed that the frequency of the series resonant circuit is accurately that of the system fundamental), of course, depends on the accuracy of the tuning and the amount of damping. If the free period of the resonant circuit differs considerably from the fundamental period of the system, the impressing on the faulty wire of a voltage in excess of normal may result, especially if the damping is small. The effect of inexact tuning is discussed by Petersen in the article referred to above. He describes some experiments in which the capacity of the power system to ground was varied some 15 or 20%, each way from the value corresponding to resonance, without apparent effect on the quenching action of the reactor.

2. Transient Overvoltage on Sound Phase at Time of Grounding

To simplify the following theoretical discussion a single phase system is treated. This is represented in Fig. 3. Referring to this

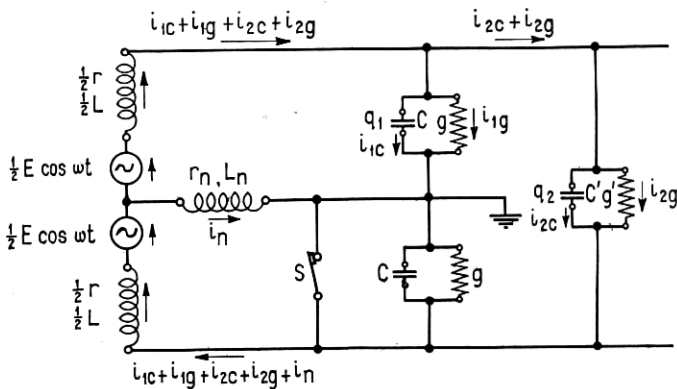

Fig. 3—Three-phase System with Neutral Grounded Through Reactor, with Fault to Ground on One Phase

figure, when one phase is grounded (represented by the closing of the switch S), the following equations, in which D denotes differentiation with respect to time, must be satisfied:

$$\Phi(D) i_n = \frac{E}{2} \cos \omega t$$

$$\frac{1}{g} \Phi(D) i_{1g} = \left[\frac{r}{2} + 2r_n + \left(\frac{L}{2} + 2L_n \right) D \right] \frac{E}{2} \cos \omega t$$

where

$$\begin{aligned} \Phi(D) = & LC'_0 \left(\frac{L}{2} + 2L_n \right) D^3 + \left[C'_0 (rL + 2L_n r + 2r_n L) + g'_0 L \left(\frac{L}{2} + 2L_n \right) \right] D^2 \\ & + \left[g'_0 (rL + 2L_n r + 2r_n L) + C'_0 \left(\frac{r^2}{2} + 2rr_n \right) + L + 2L_n \right] D \\ & + g'_0 \left(\frac{r^2}{2} + 2rr_n \right) + r + 2r_n. \\ C'_0 = & C + C', \quad g'_0 = g + g'. \end{aligned}$$

To solve the equations, the cubic equation $\Phi(D) = 0$ must be solved. An algebraic solution would be so cumbersome as to be impracticable. The following numerical values of the constants have therefore been inserted, as what is desired is a numerical solution representing the effect in a practical case:

$$\begin{array}{ll} g = 0.37 \times 10^{-6} \text{ mho} & g' = 0.18 \times 10^{-6} \text{ mho} \\ C = 0.55 \times 10^{-6} \text{ farad} & C' = 0.30 \times 10^{-6} \text{ farad} \\ L_n = 6.4 \text{ henries} & r_n = 200 \text{ ohms} \\ L = 0.022 \text{ henry} & r = 2.0 \text{ ohms} \\ E = \sqrt{2} \times 26,400 = 37,350 \text{ volts} & \omega = 377 \end{array}$$

With these assumptions

$$\Phi(D) = 2.4 \times 10^{-7} D^3 + 29.4 \times 10^{-6} D^2 + 12.8 D + 402,$$

of which the roots are

$$-31.4, \quad -45.5 + j7,300, \quad -45.5 - j7,300$$

which may be denoted by $-a'$, $-a + jb$, $-a - jb$ respectively.

The resulting equations for i_{1g} and i_n are

$$i_{1g} = P e^{-a't} + Q e^{-at} \sin(bt + \theta) + gE \cos \omega t,$$

$$i_n = P' e^{-a't} + Q' e^{-at} \sin(bt + \theta') + \frac{E}{4820} \sin(\omega t + 4^\circ.7).$$

The relations between the two sets of arbitrary constants may be obtained by inserting these solutions in the following differential equation connecting i_{1g} and i_n :

$$i_{1g}/g - \left[r/2 + 2r_n + (L/2 + 2L_n) D \right] i_n = 0,$$

and the three independent arbitrary constants so found are determined by the following conditions when $t = 0$ (it is assumed that breakdown

occurs when the impressed voltage to ground, $E \cos \omega t/2$, is a maximum):

$$i_n = 0,$$

$$i_{1g} + i_{2g} + i_{1c} + i_{2c} = (g'_0 + C'_0 D) \frac{i_{1g}}{g} = 0.0173 \text{ ampere,}$$

$$q_1 + q_2 = \frac{i_{1g}}{g} C'_0 = 0.0216 \text{ coulomb.}$$

The numerical quantities in the second and third of these equations are respectively the total current supplied to the sound wire and the total charge on this wire at the instant of breakdown. They are obtained by solving the network of Fig. 3, with switch S open and taking instantaneous values when the impressed e. m. f. is a maximum.

The resulting expressing for i_{1g} is

$$i_{1g} = 0.3 \times 10^{-6} e^{-31.4t} - 4.38 \times 10^{-3} e^{-45.5t} \cos 7300t$$

$$+ 0.37 \times 10^{-6} \times 37,350 \cos 377t.$$

The non-oscillatory term $0.3 \times 10^{-6} e^{-31.4t}$ is seen to be negligible compared to the others.

The voltage between the sound wire and ground is obtained by dividing the above result by $g = 0.37 \times 10^{-6}$, and is

$$v = 0.8e^{-31.4t} - 11,800e^{-45.5t} \cos 7,300t + 37,350 \cos 377t.$$

This equation is plotted for about $1\frac{1}{2}$ cycles of fundamental frequency in Fig. 4. The non-oscillatory term is negligible. As will be seen, the maximum overvoltage is about 30%.

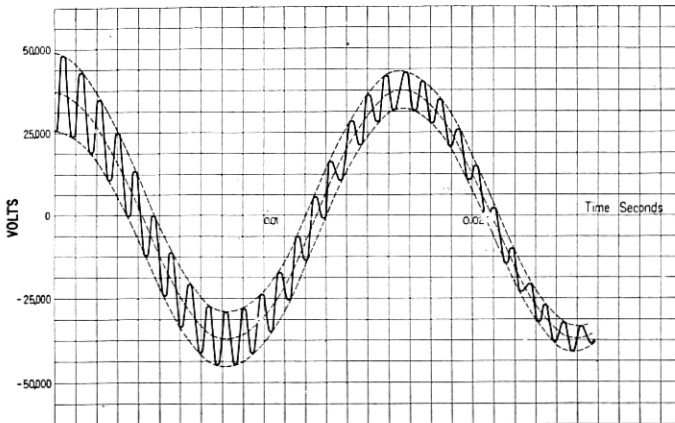

Fig. 4—Voltage from Sound Phase to Ground Following Extinction of Arc.

For comparison purposes, the voltage to ground of the sound phase with the reactor omitted (*i.e.*, with the system isolated) has been calculated, using the same constants as before. The result is

$$v' = -11,900e^{-45.8t} \cos 7310t + 37,350 \cos 377t.$$

This is practically identical with the earlier result; that is, the voltage to ground of the sound phase is practically the same with the reactor as with the system isolated.

3. *Effects with Respect to Induction in Neighboring Communication Circuits*

An estimate of the value of the Petersen coil must involve a comparison with other methods of grounding the neutral (including grounding through an infinite impedance, *i.e.*, the isolated system) or of otherwise limiting the effects of abnormal occurrences in a power system. As regards the induction of fundamental frequency voltages in exposed communication circuits, the methods of chief importance in such a comparison, at least so far as American practice is concerned, are that in which the neutral is grounded either directly or through a low resistance, and that in which the neutral is isolated.

When accidental grounds occur on a power system with neutral grounded through zero or a low impedance, the resulting heavy short circuit currents to ground may produce severe disturbances in exposed communication circuits. Owing to the fact that these disturbances are produced by electromagnetic induction in a circuit consisting of the communication conductor as one side and the earth as the other, they cannot be avoided by enclosing the communication conductors in lead-sheathed cable, even when this is placed underground.

With the Petersen coil, according to the explanation in the first part of this section, the neutral current of fundamental frequency due to a fault to ground is made equal to the charging current of the system to ground with one phase grounded, and this is generally a small fraction²—a few per cent. or less—of the neutral current in an identical system with neutral directly grounded.

The Petersen coil will thus in many cases largely prevent the electromagnetic inductive effects at fundamental frequency which appear when a fault to ground occurs on a system grounded solidly or through

² Exceptions to this statement exist in the case of extensive high voltage networks where, with a ground on one phase, the charging current to ground with isolated neutral may be of the same order of magnitude as the short circuit current with dead-grounded neutral if the fault is remote from a point of main power supply.

a low resistance. There will appear, however, electrically³ induced voltages of fundamental frequency substantially identical with those that would occur with neutral isolated. Where the communication circuits are in underground cable, these voltages are of inappreciable magnitude, and with aerial cables (with metallic sheaths) their effects can in general be controlled without great difficulty. With open wire communication circuits, electrically induced voltages are of much more consequence. They may in some cases equal or exceed the voltages which would be induced electromagnetically with dead-grounded neutral. However, except perhaps in cases of long exposure to high voltage power circuits at close separations, their effects are generally much less severe than the electromagnetic effects, because of the smaller amount of energy transferred to the disturbed circuit. This is in general accordance with experience with open wire circuits exposed to power circuits of moderate voltage. As is explained in the next paragraph, the use of a Petersen reactor to ground the neutral may be expected to lessen the severity of inductive effects which would be experienced from an isolated system, by preventing additional parts of the power system from becoming involved.

As compared to the isolated system, the use of the Petersen coil in the connection from neutral to ground may be expected to have the advantage, according to the theory of the first subdivision of this section, of preventing the formation of an "arcing ground." As experience has shown, an arcing ground in an isolated system is frequently the cause of serious disturbances which may involve portions of a network remote from the location of the original trouble. The advantage of the reactor in this respect is, of course, a fundamental one from the standpoint of power operation. It is in general of proportionate importance from the inductive interference point of view, at least where a power network is involved in parallels with communication circuits at several places, as is not infrequently the case near large cities. A breakdown to ground in the power network on a different phase from that originally involved, and in a different locality, may lead to large phase-to-phase currents in the earth, from the second fault to the first, or to a ground intentionally placed on the phase first involved, in order to short circuit the arc. The inductive effects thus become electromagnetic in character, and the interference produced in this manner may be severe.

The possibility that the reactor might tend to produce a greater

³"Electrically" is used here and elsewhere in this paper in the sense in which "electrostatically" is perhaps more commonly used. The phenomena involved are not static and the latter word is inappropriate on this account.

overvoltage on a sound phase at the instant of grounding than would be the case in an isolated system is, of course, of importance in this connection. This has been examined from a theoretical standpoint in the second subdivision of this section, with the conclusion that there is no material difference in this respect.

There remains the method of grounding in which a high resistance is employed in the connection from neutral to ground. By "high" here may be meant the "critical"⁴ resistance or one of smaller magnitude, but still so large that in the event of a solidly grounded phase, the sound phases are brought to substantially full delta voltage above ground. There are probably few cases where electromagnetic inductive effects due to accidental grounds on a power system are a matter of importance, in which a neutral resistance small enough to avoid this rise of voltage on the sound phases would be effective as a measure of relief. This method of grounding would thus not avoid the electrically induced voltages which arise when the reactor is used, although it would presumably be effective in preventing the spread of trouble to other parts of the power system if positive operation of selective relays is secured. Inasmuch as it presents fewer difficulties from this last point of view than the Petersen reactor, grounding through a moderate resistance has a definite advantage over the latter method from the standpoint of inductive effects at fundamental frequency, provided sufficient resistance can be used to limit the electromagnetically induced voltages to tolerable values.

Where this is impracticable from the standpoint of power system operation, the relative merits of the two systems would have to be decided by balancing the effective suppression of the transient electromagnetic inductive effects by means of the reactor, plus the expectation of occasional disturbances continuing over the intervals necessary for the location and disconnection of the faulty line, against the imperfect suppression of the former effects by means of the resistor, plus the limitation to very brief intervals of electrically induced disturbances otherwise the same as with the reactor. It is obvious that the factors controlling such a decision would vary widely in different cases, and that practical experience with both methods would be of great value in estimating their relative importance. It is, of course, possible that future development may remove some of the disadvantage at which the Petersen coil now finds itself in respect to the matter of relay protection for interconnected networks. Such development would presumably be of importance also to the critical

⁴ *I.e.*, the resistance for which a discharge to ground passes from the oscillatory to the non-oscillatory type.

resistance which, as a method of grounding the neutral, would generally suffice to prevent interference from ground currents at times of faults to ground, but which apparently presents difficulties from the relay standpoint similar to those involved in the use of the Petersen coil.

II. EFFECTS WITH POWER SYSTEM IN NORMAL CONDITION

1. Fundamental Frequency

Referring to Fig. 5 (we now take account of inequalities in the admittances to ground),

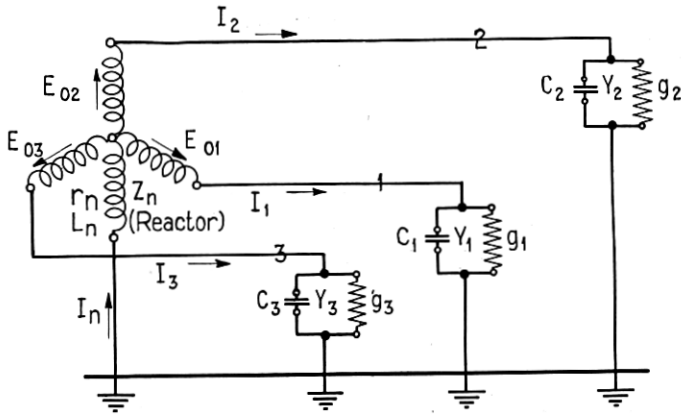

Fig. 5—Three-phase System with Neutral Grounded Through Reactor. Admittances to Ground Not Balanced.

$$E_{01} - \frac{I_1}{Y_1} = E_{02} - \frac{I_2}{Y_2} = E_{03} - \frac{I_3}{Y_3} = Z_n I_n,$$

$$I_1 + I_2 + I_3 = I_n,$$

so that

$$I_n = \frac{Y_1 E_{01} + Y_2 E_{02} + Y_3 E_{03}}{1 + Z_n Y},$$

where $Y = Y_1 + Y_2 + Y_3 =$ total direct admittance to ground. If the impressed voltages are balanced

$$I_n = \frac{E_{01}}{1 + Z_n Y} (Y_1 + Y_2 e^{j120^\circ} + Y_3 e^{j240^\circ}).$$

The parenthesis is the "residual admittance" ⁵ to ground and, if the three leakances to ground are equal, it can vanish only if

⁵ Inductive Interference between Power and Communication Circuits, California Railroad Commission, p. 269.

the three direct capacities to ground are the same. The equation is equivalent to

$$I_n = \frac{E_{rc}}{3} \frac{Y}{1 + Z_n Y},$$

where E_{rc} is the "characteristic residual voltage" ⁶ of the (isolated) system and is equal in magnitude to $3 E_{01}$ times the ratio of the residual admittance to ground to the total admittance to ground.

We have

$$YZ_n = r_n g - \omega^2 L_n C + j\omega (Cr_n + L_n g)$$

r_n and L_n being the resistance and inductance of the earth coil, and g and C the total leakage and capacity to ground, respectively. Also, for resonance

$$\omega^2 L_n C = 1$$

and hence the above expression for I_n becomes (at fundamental frequency)

$$I_n = \frac{E_{01} (Y_1 + Y_2 e^{j120^\circ} + Y_3 e^{j240^\circ})}{\frac{r_n}{\omega L_n} \frac{g}{\omega C} + j \left[\frac{r_n}{\omega L_n} + \frac{g}{\omega C} \right]}$$

if the earth coil is adjusted for accurate resonance.

If in this equation the denominator on the right be denoted by x and the fractional unbalance of the admittance to ground by y

(i.e., $y = \frac{Y_1 + Y_2 e^{j120^\circ} + Y_3 e^{j240^\circ}}{Y}$), then

$$I_n = \frac{y Y E_{01}}{x} \tag{3}$$

and, V_n being voltage between neutral and ground,

$$\begin{aligned} V_n &= Z_n I_n \\ &= \frac{y (x - 1)}{x} E_{01}. \end{aligned} \tag{4}$$

If the losses in the system (including the earth coil) are small, x is small compared to 1. Thus we get, for the absolute value of V

$$|V_n| = \left| \frac{y}{x} \cdot E_{01} \right|, \text{ approximately}$$

and the absolute value of the residual voltage is three times this, approximately.

⁶ *Ibid.*, p. 257.

In substance, this means that, at fundamental frequency and with small losses, the fractional admittance unbalance should be kept small compared to the ratio of the resistance to the reactance of the coil, if unduly high voltages to ground are to be avoided. (It is supposed that $g/\omega C$ is of the order of $r_n/\omega L_n$, or smaller—a condition probably satisfied even with the best practicable design of coil, except under very wet line conditions.) The point involved here is, of course, an important one from the standpoint of power system operation. It is also important from the standpoint of electrically induced voltages in exposed communication circuits. The admittance unbalance can be kept within the necessary limits by suitable power circuit transpositions.

The absolute magnitude of the fundamental frequency neutral current is obtained from the expression for $|V_n|$ by dividing by the coil impedance (or directly from equation (3), and is, approximately,

$$|I_n| = \frac{|yE_{01}|}{r_n + \frac{g}{\omega C} \cdot \omega L_n}.$$

For a system with dead-grounded neutral the fundamental frequency residual current is $yE_{01}Y$ and is thus smaller than that just found for the case of the reactor in the ratio of $|x|$ to 1, approximately. It is evident, however, that the magnitude of the neutral current with reactor is controllable by means of transpositions, as in the case of the neutral and residual voltages. The inductive effects of this current should be of small consequence with an amount of transposing sufficient to keep the line voltages to ground within limits desirable from the standpoint of power system operation.

2. Harmonics

In the following discussion, we retain the assumption of lumped constants, so that the results are not applicable to extensive networks without modification.

With this restriction, at harmonic frequencies other than the third or one of its odd multiples, the above approximate equation for V_n becomes

$$V_n = \frac{y'(x' - 1)}{-1 + \frac{1}{m^2} + x'} \cdot E_{01}, \text{ approximately,}$$

m being the order and E_{01} the voltage of the harmonic and x and y accented to denote that they are to be taken for the frequency in

question. For small losses x' may be neglected in comparison with unity, as before, giving

$$|V_n| = \frac{|y' E_{01}|}{1 - \frac{1}{m^2}}, \text{ approximately.} \quad (5)$$

For isolated neutral

$$|V_n| = |y' E_{01}|. \quad (6)$$

Thus, even for the fifth harmonic, the right hand side of (5) is only 4 per cent. in excess of the value it would have if the neutral were isolated.

For harmonics whose orders are not divisible by three the residual voltage is three times V_n . Thus from the standpoint of noise interference from voltages, a system grounded through a Petersen coil behaves practically as though the neutral were isolated, so far as these harmonics are concerned. As with the fundamental, power circuit transpositions are available for the reduction of residual voltages of these frequencies.

Residual currents of frequencies belonging to this series of harmonics, which are not present at the ends of the line with isolated neutral, are introduced by grounding through the reactor, but they are of minor importance, as may be judged by comparing the neutral currents with the reactor and with dead grounded neutral. With the reactor, the neutral current of a harmonic of order m not a multiple of 3 is found from (5) to be, in absolute value,

$$|I_n| = \frac{m |y' E_{01}|}{(m^2 - 1) |Z_n|}, \text{ approximately,}$$

Z_n being the coil impedance at fundamental frequency, while with dead-grounded neutral, it would be

$$|I_n| = |E_{01} y' m Y|, \text{ approximately,}$$

in which Y is the total admittance to ground at fundamental frequency. Thus the magnitude of the neutral current with the reactor is approximately $1/(m^2 - 1)$ of its magnitude with dead-grounded neutral. The noise effects of residual currents of these magnitudes will generally be insignificant compared to those arising from other sources, particularly if the power circuit capacities to ground are well balanced.

For the third harmonic, or one of its odd multiples, we get

$$V_n = Z'_n I_n = \frac{E_{01} Z'_n Y'}{1 + Z'_n Y'},$$

in which the symbols for coil impedance and line admittance are accented to denote that they refer to the harmonic frequency in question;

$$V_n = \frac{E_{01} m^2 (x' - 1)}{1 + m^2 (x' - 1)};$$

and

$$|V_n| = \frac{|E_{01}|}{1 - \frac{1}{m^2}}, \text{ approximately.}$$

For isolated neutral,

$$V_n = E_{01}$$

The neutral is thus subjected to a third harmonic voltage some 12 per cent. greater than if it were isolated, but for the higher harmonics belonging to this series (of the third and its odd multiples), the difference is inappreciable.

The residual voltage for a harmonic of this series is

$$\begin{aligned} V_r &= 3(E_{01} - V_n) \\ &= 3E_{01} \frac{1}{1 + m^2(x' - 1)}; \end{aligned} \quad (7)$$

and

$$|V_r| = \frac{3|E_{01}|}{m^2 - 1}, \text{ approximately.} \quad (8)$$

The corresponding neutral current is

$$I_n = \frac{|E_{01} Y'|}{1 + Z'_n Y'}$$

and

$$|I_n| = \frac{|E_{01} Y'|}{m^2 - 1}, \text{ approximately.} \quad (9)$$

From the standpoint of noise interference in telephone circuits, residuals of the series consisting of the third harmonic and its odd multiples are frequently troublesome where the neutral of a three-phase system is grounded directly or through a low resistance. These residuals, of course, are not affected by power circuit transpositions, either as to their magnitudes or as to their inductive effects upon exposed telephone circuits. It is therefore of interest to examine the expressions just obtained for the case in which the neutral is grounded through the coil. While the neutral current will not be the same as

the residual current except when only one line is supplied from the transformer bank, the effect upon the former should in general be at least approximately proportional to the effect upon the residual current in any line supplied from the bank.

In writing equation (7), any difference between the induced voltage E_{01} and the voltage appearing between line and neutral has been ignored. To the extent that this is justifiable, the expressions for the case of the solidly grounded neutral may be obtained by making the denominators of the right hand sides of (8) and (9) each unity. If the transformer bank is provided with a delta winding of low impedance, in particular if it is connected delta on one side, this procedure gives a fair approximation to the correct expressions, since the impedance through which the voltage E_{01} regulates is in this case merely the transformer leakage impedance. The resulting conclusions with respect to the advantage of the reactor—for example, that the third harmonic residual voltage or neutral current is $1/8$ as large, the ninth $1/80$ as large, etc., with the reactor as with solidly grounded neutral—should not, in any event, be unfavorable to the latter method of grounding unless the electrical length of the line approaches the point at which its reactance to ground becomes positive.

If the transformers are so connected as to provide no path for triple harmonic magnetizing currents other than through line admittance to ground and the impedance between neutral and ground, the induced voltage E_{01} is not the same for the two methods of grounding under consideration, because the impedance to the triple harmonic magnetizing currents is appreciably different in two cases. A convenient method of taking this effect into account is to regard the induced voltage as due to a fictitious impedanceless generator of determinate voltage regulating through the mutual impedance of the transformer windings for the frequency in question.⁷ If Z'_m is one-third of this mutual impedance and V_{01} ⁸ is the voltage of the fictitious generator, the expression for the neutral current with ground connection through the reactor becomes

$$I_n = \frac{V_{01} Y'}{1 - m^2 + Y' Z'_m}, \text{ approximately,} \quad (10)$$

⁷ H. S. Osborne, Trans. A. I. E. E. 34, p. 2175, 1915.

⁸ The voltage thus assumed is, of course, not identical with the induced voltage for which the symbol E_{01} has hitherto been used, and for this reason the new symbol V_{01} is used for it. The corresponding E_{01} would be V_{01} diminished by the drop through the mutual impedance.

and the residual voltage is

$$\begin{aligned} V_r &= 3 (V_{01} - I_n Z'_m - V_n) \\ &= \frac{3V_{01}}{1 - m^2 + Y' Z'_m} \text{ approximately.} \end{aligned} \quad (11)$$

The corresponding expressions for solidly grounded neutral are obtained by omitting m^2 in the denominator for each of the equations just derived. Thus the advantage of grounding through the reactor relative to grounding directly depends on the magnitude of $Y' Z'_m$ as compared to the square of the order of the harmonic. Z'_m depends upon the voltage and the kva. capacity of the transformers and is mostly inductive reactance. For high voltage transformer banks of small capacity feeding very extensive networks, the gain indicated by equations (10) and (11) from the use of the reactor would probably not be large. It would be important, however, where the aggregate capacity of the supply transformers is moderate or large and the connected network is of moderate extent and voltage. For instance, using the data of the example considered in an earlier part of this paper and taking $Z'_m = jL'_m \omega' = \frac{1}{3} \cdot j 9,000$ as an appropriate value

for a total transformer capacity of 7,000 to 8,000 kva., with line voltage from 20,000 to 30,000, we should have $L'_m C \omega'^2$ equal to about 4 at 180 cycles/sec. In other words, in this case, the employment of the reactor would reduce the residual voltage and the neutral current of the third harmonic frequency due to a star-star solidly grounded transformer bank by about 75 per cent., and residuals of other frequencies belonging to the same series probably by larger amounts.

In the earlier discussion relating to harmonics not belonging to the triple series, comparison was made between a system grounded through a Petersen reactor and the isolated system. In a similar comparison with respect to the triple harmonic series, the isolated system has the advantage, since residuals of this series theoretically do not appear in such a system, as the voltages are not impressed between wires. As a practical matter, an isolated system would probably not be entirely free of triple harmonic residuals, owing to dissimilarities in transformers or elsewhere. Such accidental effects can hardly be taken into account in a theoretical discussion. However, in setting up a comparison between the isolated system and that grounded through the reactor, an idea of the relative importance of the triple harmonic residual voltages existing in the latter case can perhaps be obtained by comparing their theoretical magnitudes with the theoretic-

cal magnitudes of residual voltages in the isolated system of non-triple frequencies.

The residual voltage due to one of these non-triple frequencies, which is three times the neutral voltage, is $3y' E'_{01}$, according to equation (6). Here y' is the fractional residual admittance and E'_{01} may be taken as the induced voltage in the transformer for the frequency in question. For a harmonic belonging to the triple series, with neutral grounded through the reactor, the absolute value of the residual voltage is $\frac{3 |E''_{01}|}{m^2 - 1}$ (equation (8)) m being the order of

the harmonic and E''_{01} the induced voltage, if we assume the transformer bank provided with a low impedance path for triple harmonics, and therefore neglect the difference between the induced and the terminal voltages. The ratio of the triple-series residual voltage to the other is thus, in absolute value, $\frac{|E''_{01}|}{(m^2 - 1) |y' E'_{01}|}$.

If we take the ninth as the harmonic of the triple series and assume equal values of the induced voltages E''_{01} and E'_{01} it will be seen that $|y'|$ must be of the order of 0.01 if the residual voltage of the triple harmonic series is to be as large as the other. This amount of unbalance is somewhat larger than has been found at this frequency (540 cycles/sec.) in an actual transposed line.⁹ If we consider the higher harmonics of the triple series, $|y'|$ would have to be made progressively smaller in order that the ratio might remain unity. Thus, for the 21st harmonic, $|y'|$ would have to be of the order of 0.002. While, of course, $|y'|$ may be made as small as desired by sufficiently close power circuit transpositions, it appears that in practical cases where transformer banks have delta windings, one may expect the residual voltages of the triple series, introduced by changing from an isolated system to one grounded through the reactor, to be relatively unimportant except in the case of the third harmonic and perhaps in that of the ninth. This statement would not be true if, as with star-star transformers under some circumstances, no low impedance path is provided for magnetizing currents of the triple harmonic series. Such cases are not common in operating practice.

The method of estimating comparative effects here applied to the case of triple harmonic residual voltages is not available for residual currents. To take account of the latter in comparing the isolated

⁹ Inductive Interference between Power and Communication Circuits, California Railroad Commission, Technical Report No. 51.

system and the system with neutral grounded through the reactor, recourse may be had to the indirect method of reference to the solidly grounded neutral system, as in the discussion of residual currents of the non-triple series on page 52. Such a procedure, of course, involves a reference to general experience also. It has been shown in the earlier discussion that for a triple series harmonic of order m the neutral current with the reactor is approximately $1/(m^2 - 1)$ as large as with the dead-grounded neutral if a low impedance path for triple frequency magnetizing currents is provided, as by a delta winding. The establishment of this system of neutral currents, even though they are small, when a previously isolated system is grounded through a Petersen reactor, constitutes an addition to the residuals which produce induction in neighboring circuits. However, it is not to be expected that the added inductive effects would be important. Where no low impedance path for the triple series magnetizing currents exists, the reactor is relatively less effective in suppressing residual currents of this series. The triple harmonic neutral currents of a power system connected in this manner and grounded through a Petersen coil might in some cases lead to inductive effects of some significance.

In general, for harmonics of orders not divisible by three, grounding through a moderate resistance (large, however, compared to other impedances involved in a short circuit to ground) will be more advantageous as regards residual voltages, and less advantageous as regards residual currents, than grounding through the reactor. Grounding through zero impedance would, of course, generally lead to the smallest residual voltages and the largest residual currents of these frequencies. For frequencies belonging to the triple series, grounding through the reactor will be considerably more advantageous than grounding through a moderate resistance as regards both residual voltages and residual currents. It may be expected that with moderate neutral resistance, residual currents and voltages of the triple series will both be nearer in magnitude to those obtaining with zero neutral impedance than to those obtaining with the Petersen coil. The moderate neutral resistance is relatively more effective at the higher frequencies in reducing residual currents of all harmonics and residual voltages of the triple series; for harmonic residual voltages not belonging to the triple series, it is relatively more effective at the lower frequencies.

I wish to express my gratitude for helpful suggestions and criticism received in the preparation of this paper from Messrs. L. P. Ferris and R. G. McCurdy, and also from Mr. R. K. Honaman.

SUMMARY

1. At times of a fault to ground on a power system with neutral grounded through a Petersen reactor, the action of the latter tends to extinguish the arc and to prevent its restriking. Theoretical considerations, applied to a practical case, indicate that the transient over-voltage on a sound phase at the instant of occurrence of the fault is substantially the same as in a system with isolated neutral.

2. Grounding the neutral through a Petersen earth coil instead of directly or through a low resistance would largely prevent the electromagnetic inductive effects to which exposed communication circuits are liable at times of faults to ground in systems grounded in the latter manner. (Extensive high voltage networks are perhaps an exception to this statement. But even here, the electromagnetic inductive effects would in general not be greater with the reactor than with isolated neutral.) However, effects due to electric induction similar to those from an isolated system may be expected to appear. Except for long, close parallels involving open-wire communication circuits these effects should in general be much less severe than the electromagnetic inductive effects from a system with dead-grounded neutral. The extent and severity of the inductive effects experienced from the system grounded through the reactor would further tend to be smaller than with the isolated system, because of the effect of the reactor in preventing arcing grounds.

3. Grounding the neutral through a resistance large compared to other impedances involved in a short circuit to ground should have an advantage over grounding through the Petersen reactor, in that the former method presents fewer difficulties in respect to power system protective relays, so that it would reduce the possibility of the continuance of inductive disturbances over considerable periods of time, which might be involved in grounding through the reactor, under present relay practice. From an inductive interference standpoint, a choice between the two methods would depend upon the circumstances of particular cases. Advances in the art of relay protection would improve the position of the reactor in such considerations.

4. Under normal power system operating conditions, the use of the reactor may lead to excessive residual voltages of fundamental frequency if the admittances from phases to ground are unbalanced. Such unbalance may be reduced to the extent necessary from this point of view by power circuit transpositions.

5. Under normal operating conditions, it is to be expected that the residual voltages and currents of the triple harmonic series occurring

with neutral grounded through zero or a low impedance would be largely reduced by grounding through the Petersen reactor instead. Residuals of other harmonic frequencies should be substantially the same as with isolated neutral, and are controllable by means of power circuit transpositions. The method of grounding the neutral through a resistance of moderate value is favorable to the reduction of residual voltages of the harmonics whose orders are not multiples of three, but is relatively unfavorable to the suppression of residual currents of these frequencies. It is also considerably less effective than the reactor in preventing residuals, either voltages or currents, belonging to the triple harmonic series, which are not amenable to treatment by transpositions.