

Tektronix[®]
COMMITTED TO EXCELLENCE

**TYPE
453/R453
OSCILLOSCOPE
ABOVE SN 20,000**

INSTRUCTION MANUAL

TEKTRONIX®

**TYPE
453/R453
OSCILLOSCOPE
ABOVE SN 20,000**

INSTRUCTION MANUAL

Tektronix, Inc.
P.O. Box 500
Beaverton, Oregon 97077

Serial Number _____



WARRANTY

All Tektronix instruments are warranted against defective materials and workmanship for one year.

Any questions with respect to the warranty mentioned above should be taken up with your Tektronix Field Engineer.

Tektronix repair and replacement-part service is geared directly to the field, therefore all requests for repairs and replacement parts should be directed to the Tektronix Field Office or representative in your area. This procedure will assure you the fastest possible service. Please include the instrument Type and Serial or Model Number with all requests for parts or service.

Specifications and price change privileges reserved.

Copyright© 1967, new material 1970 by Tektronix, Inc., Beaverton, Oregon. Printed in the United States of America. All rights reserved. Contents of this publication may not be reproduced in any form without permission of the copyright owner.

TABLE OF CONTENTS

SECTION 1 TYPE 453/R453 SPECIFICATIONS	Page		
Introduction	1-1	Signal Connections	2-11
Electrical	1-1	Loading Effect of the Type 453	2-11
Vertical Deflection System	1-1	Coaxial Cable Considerations	2-12
Triggering (A and B Sweep)	1-2	Input Coupling	2-12
Horizontal Deflection System	1-2	Deflection Factor	2-12
A and B Sweep Generator	1-2	Dual-Trace Operation	2-12
Sweep Magnifier	1-3	Channel 1 Output and Cascaded	
Sweep Delay	1-3	Operation	2-13
External Horizontal Amplifier	1-3	Algebraic Addition	2-13
Calibrator	1-3	Trigger Source	2-14
Z Axis Input	1-4	Trigger Coupling	2-14
Output Signals	1-4	Trigger Slope	2-14
Power Supply	1-4	Trigger Level	2-16
Cathode-Ray Tube (CRT)	1-4	High-Frequency Stability	2-16
Environmental	1-4	A Sweep Triggered Light	2-16
Mechanical	1-5	A Sweep Mode	2-16
Standard Accessories	1-5	Selecting Sweep Rate	2-16
		Sweep Magnification	2-17
		Delayed Sweep (B)	2-17
		External Horizontal Deflection	2-19
		A and B Gate	2-20
		Intensity Modulation	2-20
		Calibrator	2-20
SECTION 2 OPERATING INSTRUCTIONS		Basic Applications	
General	2-1	General	2-20
Front Cover and Handle	2-1	Peak to Peak Voltage	
Operating Voltage	2-1	Measurements—AC	2-20
Operating Temperature	2-2	Instantaneous Voltage	
Rackmounting	2-2	Measurements—DC	2-21
Controls and Connectors	2-2	Voltage Comparison Measurements	2-21
First-Time Operation	2-6	Time-Duration Measurements	2-22
Control Setup Chart	2-8	Frequency Measurements	2-22
General Operating Information		Risetime Measurements	2-23
Intensity Control	2-8	Time-Difference Measurements	2-23
Astigmatism Adjustment	2-8	Delayed Sweep Time Measurements	2-24
Graticule	2-10	Delayed Sweep Magnification	2-25
Trace Alignment Adjustment	2-10	Displaying Complex Signals Using	
Light Filter	2-10	Delayed Sweep	2-26
Trace Finder	2-11	Pulse Jitter Measurements	2-26
Vertical Channel Selection	2-11		
Vertical Gain Adjustment	2-11		
Step Attenuator Balance	2-11		

Type 453/R453

Delayed Trigger Generator	2-26
Normal Trigger Generator	2-27
Multi-Trace Phase Difference Measurements	2-28
High Resolution Phase Measurements	2-28
X-Y Phase Measurements	2-28
Common-Mode Rejection	2-30

SECTION 3 CIRCUIT DESCRIPTION

Introduction	3-1
Block Diagram	
General	3-1
Circuit Operation	
General	3-3
Channel 1 Vertical Preamp	
General	3-3
Input Coupling	3-3
Input Attenuator	3-3
Input Stage	3-4
Feedback Amplifier	3-4
Channel 1 Trigger Pickoff	3-4
Paraphase Amplifier	3-4
Channel 2 Vertical Preamp	
General	3-6
Feedback Amplifier	3-6
Paraphase Amplifier	3-6
Vertical Switching	
General	3-6
Diode Gates	3-6
Switching Multivibrator	3-7
Delay-Line Driver	3-8
Normal Trigger Pickoff Network	3-8
Vertical Output Amplifier	
General	3-8
Delay Line	3-8
Phase Equalizer Network	3-8
Output Amplifier	3-9
Trigger Preamp	
General	3-9
Input Circuitry	3-9
Amplifier Circuitry	3-10

A Trigger Generator	
General	3-10
Trigger Source	3-11
Trigger Coupling	3-11
Input Stage	3-12
Slope Comparator	3-12
Trigger TD	3-12
Pulse Amplifier	3-12
Auto Pulse Amplifier	3-13
Auto Multivibrator	3-13
A Sweep Generator	
General	3-14
Normal Trigger Mode Operation	3-15
Auto Trigger Mode Operation	3-17
Single Sweep Operation	3-17
B Trigger Generator	
General	3-17
Input Stage	3-18
Pulse Amplifier	3-18
B Sweep Generator	
General	3-19
Output Signal Amplifier	3-19
Delay-Pickoff Comparator	3-19
Delay Multivibrator	3-20
Sweep Reset Multivibrator	3-20
B Ends A Pulse Amplifier	3-20
Horizontal Amplifier	
General	3-20
Input Amplifiers	3-21
Paraphase Amplifier	3-21
Output Amplifier	3-22
Z Axis Amplifier	
General	3-22
Input Amplifier	3-22
Output Amplifier	3-23
CRT Circuit	
General	3-23
High-Voltage Oscillator	3-23
High-Voltage Regulator	3-24
High-Voltage Rectifiers and Output	3-24
CRT Control Circuits	3-25
External Z Axis Input	3-25

Low-Voltage Power Supply	
General	3-25
Power Input	3-25
-12-Volt Supply	3-25
+12-Volt Supply	3-27
+75-Volt Supply	3-27
+150-Volt Unregulated Supply	3-27
6.3-Volt RMS AC Source	3-28
Voltage Distribution	3-28
Calibrator	
General	3-28
Oscillator	3-28
Output Amplifier	3-28
Output Divider	3-28

SECTION 4 MAINTENANCE

Introduction	4-1
Cover Removal	4-1
Preventative Maintenance	
General	4-1
Cleaning	4-1
Lubrication	4-2
Visual Inspection	4-2
Transistor Checks	4-2
Recalibration	4-2
Troubleshooting	
Introduction	4-2
Troubleshooting Aids	4-2
Troubleshooting Equipment	4-4
Troubleshooting Techniques	4-4
Corrective Maintenance	
General	4-8
Obtaining Replacement Parts	4-8
Soldering Techniques	4-8
Component Replacement	4-9
Recalibration After Repair	4-12
Instrument Repackaging	4-12

SECTION 5 PERFORMANCE CHECK/CALIBRATION PROCEDURE

Introduction	5-1
Test Equipment Required	
General	5-1
Short-Form Calibration Procedure and Index	5-2
Performance Check/Calibration Procedure	
General	5-6
Preliminary Procedure	5-6
Check or Adjust	5-8

SECTION 6 RACKMOUNTING

Introduction	6-1
Rack Dimensions	6-1
Slide-Out Tracks	6-1
Mounting Procedure	6-1
Alternative Rear Mounting Methods	6-2
Removing or Installing the Instrument	6-2
Slide-Out Track Lubrication	6-2

SECTION 7 ELECTRICAL PARTS LIST

Abbreviations and Symbols
Parts Ordering Information
Index of Electrical Parts List
Electrical Parts List

SECTION 8 DIAGRAMS AND MECHANICAL PARTS ILLUSTRATIONS

Diagrams
Mechanical Parts Illustrations

SECTION 9 MECHANICAL PARTS LIST

Mechanical Parts List Information
Index of Mechanical Parts Illustrations
Mechanical Parts List

CHANGE INFORMATION

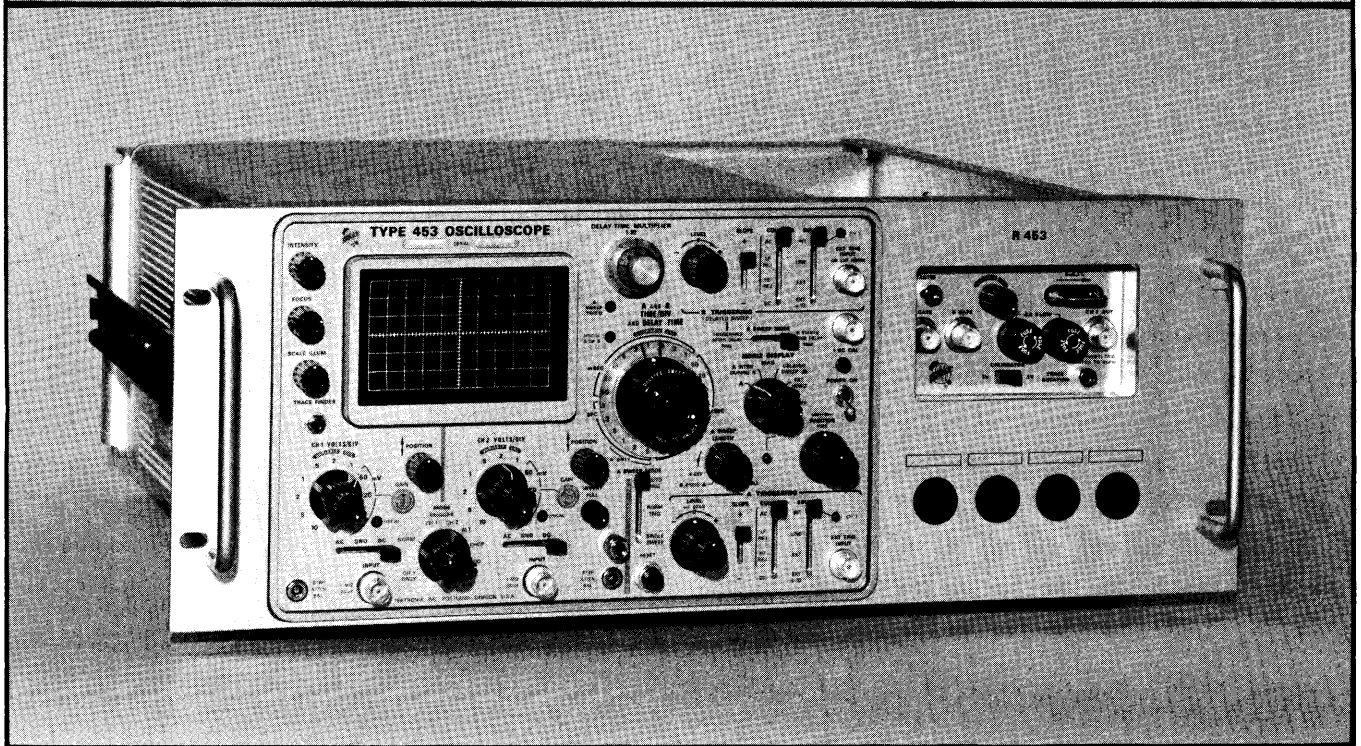
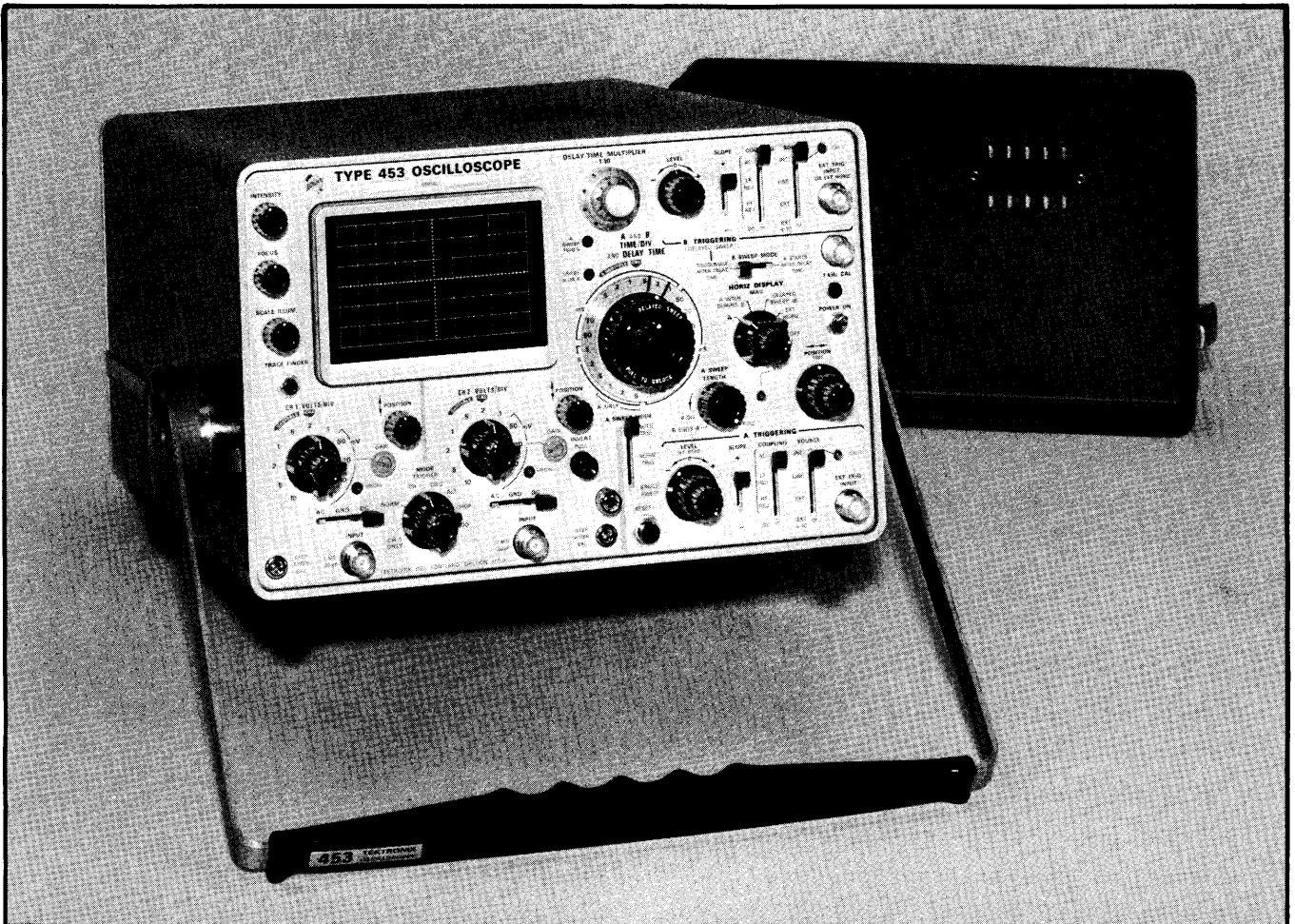

Fig. 1-1. Top; the Type 453 Oscilloscope. Bottom; the Type R453 Oscilloscope.

SECTION 1

TYPE 453/R453 SPECIFICATIONS

Change information, if any, affecting this section will be found at the rear of the manual.

Introduction

The Tektronix Type 453 Oscilloscope is a transistorized portable oscilloscope designed to operate in a wide range of environmental conditions. The light weight of the Type 453 allows it to be easily transported, while providing the performance necessary for accurate high-frequency measurements. The dual-channel DC-to-50 MHz vertical system provides calibrated deflection factors from 5 millivolts to 10 volts/division. Channels 1 and 2 can be cascaded using an external cable to provide a one millivolt minimum deflection factor (both VOLTS/DIV switches set to 5 mV).

The trigger circuits provide stable triggering over the full range of vertical frequency response. Separate trigger controls are provided to select the desired triggering for the A and B sweeps. One of three sweep modes can be selected for the A sweep; automatic, normal, or single sweep. The horizontal sweep provides a maximum sweep rate of 0.1 microsecond/division (10 nanoseconds/division using 10X magnifier) along with a delayed sweep feature for accurate relative-time measurements. Accurate X-Y measurements can be made with Channel 2 providing the vertical deflection, and Channel 1 providing the horizontal deflection. (TRIGGER switch set to CH 1 ONLY, HORIZ DISPLAY switch set to EXT HORIZ). The regulated DC power supplies maintain constant output over a wide variation of line voltages and frequencies. Total power consumption of the instrument is approximately 90 watts.

Information given in this instruction manual applies to the Type R453 also unless otherwise noted. The Type R453 is electrically identical to the Type 453 but is mechanically adapted for mounting in a standard 19-inch rack. Rack-mounting instructions, a mechanical parts list and a dimensional drawing for the Type R453 are provided in Section 6 of this manual.

The following electrical characteristics apply over a calibration interval of 1000 hours at an ambient temperature range of -15°C to $+55^{\circ}\text{C}$, except as otherwise indicated. Warm-up time for given accuracy is 20 minutes.

ELECTRICAL

VERTICAL DEFLECTION SYSTEM

Characteristic	Performance Requirement
Deflection Factor	5 millivolts/division to 10 volts/division in 11 calibrated steps (1, 2, 5 sequence) for each channel. One millivolt/division when Channel 1 and 2 are cascaded.
Deflection Accuracy	Within $\pm 3\%$ of indicated deflection with VARIABLE control set to CAL. Cascaded deflection factor uncalibrated.

Characteristic	Performance Requirement
Variable Deflection Factor	Uncalibrated deflection factor at least 2.5 times the VOLTS/DIV switch indication. This provides a maximum uncalibrated deflection factor of 25 volts/division in the 10 volts position.
Bandwidth at Upper -3 dB point (with or without P6010 Probe) when driven from $25\ \Omega$ source.	
20 mV to 10 VOLTS/DIV	DC to 50 MHz or greater
10 mV/DIV	DC to 45 MHz or greater
5 mV/DIV	DC to 40 MHz or greater
Channels 1 and 2 cascaded	DC to 25 MHz or greater
Risetime (with or without P6010 Probe) when driven from $25\ \Omega$ source	
20 mV to 10 VOLTS/DIV	Less than 7 nanoseconds
10 mV/DIV	Less than 7.8 nanoseconds
5 mV/DIV	Less than 8.75 nanoseconds
Channels 1 and 2 cascaded	Less than 14 nanoseconds
Trace Drift Time	
5 mV/DIV	Typically less than 0.08 div/h
10 mV/DIV	Typically less than 0.05 div/h
20 mV through 10 V/DIV	Typically less than 0.03 div/h
Temperature	
5 mV/DIV	Typically less than 0.02 div/ $^{\circ}\text{C}$
10 mV/DIV	Typically less than 0.0125 div/ $^{\circ}\text{C}$
20 mV through 10 V/DIV	Typically less than 0.0075 div/ $^{\circ}\text{C}$
Input RC Characteristics	
Resistance	1 megohm $\pm 2\%$
Capacitance	20 picofarads \pm picofarad
Maximum Input Voltage	600 volts DC + peak AC (one kilohertz or less). Peak to peak AC not to exceed 600 volts.
Input Coupling Modes	AC or DC, selected by front-panel switch.
AC Low-Frequency Response (lower -3 dB point)	
Without probe	Typically 1.6 Hz, Input Coupling switch set to AC.

Specifications—Type 453/R453

Characteristic	Performance Requirement
With P6010 Probe	Typically 0.16 Hz.
Trace Shift Due to Input Gate Current (at 25° C)	Negligible
Vertical Display Modes	Channel 1 only Channel 2 only Dual-trace, alternate between channels Dual-trace, chopped between channels Added algebraically
Chopped Repetition Rate	Approximately one-microsecond segments from each channel displayed at repetition rate of 500 kHz, $\pm 20\%$.
Attenuator Isolation	Greater than 10,000:1, DC to 20 MHz.
Common Mode Rejection Ratio	Greater than 20:1 at 20 MHz for common-mode signals less than eight times VOLTS/DIV switch setting (with optimum GAIN adjustment at low frequency).
Linear Dynamic Range Useful for Common-Mode Rejection in ADD Mode	Less than 10% incremental signal distortion for instantaneous input voltage of -10 or $+10$ times VOLT/DIV switch setting.
Polarity Inversion	Displayed signal from Channel 2 can be inverted.
Signal Delay Line	Permits viewing of leading edge of triggering signal (internal triggering only). Delay approximately 140 nanoseconds.
Low-Frequency Vertical Linearity	Less than 0.15 division compression or expansion of two division one-kilohertz square wave signal when positioned to vertical extremes of display area (includes CRT linearity).

TRIGGERING (A AND B SWEEP)

Characteristic	Performance Requirement
Source	Internal from displayed channel or from Channel 1 only. Internal from AC power source. External External divide by 10
Coupling	AC AC low-frequency reject AC high-frequency reject DC
Polarity	Sweep can be triggered from positive-going or negative-going portion of trigger signal.
Internal Trigger Sensitivity AC	0.2 division of deflection, minimum, 30 Hz to 10 MHz; increasing to 1 division at 50 MHz.

Characteristic	Performance Requirement
LF REJ	0.2 division of deflection, minimum 30 kHz to 10 MHz; increasing to 1 division at 50 MHz.
HF REJ	0.2 division of deflection, minimum 30 Hz to 50 kHz.
DC	0.2 division of deflection, minimum DC to 10 MHz; increasing to 1 division at 50 MHz.
External Trigger Sensitivity AC	50 millivolts, minimum, 30 Hz to 10 MHz; increasing to 200 millivolts at 50 MHz.
LF REJ	50 millivolts, minimum, 30 kHz to 10 MHz; increasing to 200 millivolts at 50 MHz.
HF REJ	50 millivolts, minimum, 30 Hz to 50 kHz.
DC	50 millivolts, minimum, DC to 10 MHz; increasing to 200 millivolts at 50 MHz.
Auto Triggering (A sweep only)	Stable display presented with signal amplitudes given under Internal and External Trigger Sensitivity above 20 Hz. Presents a free-running sweep for lower frequencies or in absence of trigger signal.
Single Sweep (A sweep only)	A Sweep Generator produces only one sweep when triggered. Further sweeps are locked out until RESET button is pressed. Trigger sensitivity same as given above.
Display Jitter	Less than 1 nanosecond at 10 nanoseconds/division sweep rate (MAG switch set to X10)
Maximum Input Voltage	600 volts DC + peak AC (one kilohertz or less). Peak to peak AC not to exceed 600 volts.
External Trigger Input RC Characteristics (approximate)	1 megohm paralleled by 20 pF, except in LF REJ
LEVEL Control Range	At least ± 2 volts, SOURCE switch in EXT position. At least ± 20 volts, SOURCE switch in EXT $\div 10$ position.

HORIZONTAL DEFLECTION SYSTEM

A and B Sweep Generator

Characteristic	Performance Requirement
Sweep Rates A sweep	0.1 microsecond/division to 5 seconds/division in 24 calibrated steps (1,2,5 sequence)
B sweep	0.1 microsecond/division to 0.5 second/division in 21 calibrated steps (1,2,5 sequence)

Specifications—Type 453/R453

Characteristic	Performance Requirement	
Sweep Accuracy— A and B Sweep	0° C to +40° C	−15° C to +55° C
5 s to 0.1 s/DIV	Within ±3% of indicated sweep rate	Within ±5% of indicated sweep rate
50 ms to 0.1 μs/DIV	Within ±3% of indicated sweep rate	Within ±4% of indicated sweep rate
Variable Sweep Rate	Uncalibrated sweep rate to at least 2.5 times the TIME/DIV indication, or a maximum of at least 12.5 seconds/division in the 5 s position (B sweep, maximum of 1.25 seconds/division in the .5 s position).	
Sweep Length at 1 ms/ DIV	Variable from less than 4 divisions to 11.0, ±0.5 division.	
A sweep		
B sweep	11.0 divisions, ±0.5 division	
Sweep Hold-off—A sweep	Not to exceed one times the A TIME/DIV switch setting with the HF STAB control fully counterclockwise	
5 s to 10 μs/DIV		
5 μs to 0.1 μs/DIV	Not to exceed 2.5 microseconds with HF STAB control set fully counterclockwise	

Sweep Magnifier

Characteristic	Performance Requirement
Sweep Magnification	Each sweep rate can be increased 10 times the indicated sweep rate by horizontally expanding the center division of display
Magnified Sweep Accuracy	1% tolerance added to specified sweep accuracy
Magnified Sweep Linearity	±1.5% for any eight division portion of the total magnified sweep length (excluding first and last 60 nanoseconds of magnified sweep)
Normal/Magnified Registration	±0.2 division, or less, trace shift at graticule center when switching MAG switch from X10 to OFF

Sweep Delay

Characteristic	Performance Requirement
Calibrated Delay Time Range	Continuous from 50 seconds to 1 microsecond.
DELAY-TIME MULTIPLIER Dial Range	0.20 to 10.20

Characteristic	Performance Requirement	
Delay Time Accuracy	0° C to +40° C	−15° C to +55° C
5 s to 0.1 s/DIV	Within ±2.5% of indicated delay	Within ±3.5% of indicated delay
50 ms to 1 μs/DIV	Within ±1.5% of indicated delay	Within ±2% of indicated delay
Incremental Multiplier Linearity	±0.2%	±0.3%
Delay Time Jitter	Less than 1 part in 20,000 of 10 times A TIME/DIV switch setting.	

External Horizontal Amplifier

Characteristic	Performance Requirement	
Input to Channel 1 (TRIGGER switch to CH 1 ONLY) Deflection Factor	5 millivolts/division to 10 volts/division in 11 calibrated steps (1, 2, 5 sequence)	
Accuracy	0° C to +40° C	−15° C to +55° C
	Within ±5% of indicated deflection	Within ±8% of indicated deflection
X Bandwidth at Upper −3 dB Point	5 MHz or greater	
Input RC Characteristics		
Resistance	1 megohm ±2%	
Capacitance	20 picofarads ±3%	
Phase difference between X and Y amplifiers	Less than 3° at 50 kHz	
Input to EXT HORIZ Connector Deflection Factor	B SOURCE switch in EXT; 270 millivolts/division, ±15% B SOURCE switch in EXT ÷10; 2.7 volts/division, ±20%	
X Bandwidth at Upper −3 dB point	5 MHz or greater	
Input RC Characteristics (approximate)	1 megohm paralld by 20 pF	
Phase difference between X and Y amplifiers	Less than 3° at 50 kHz	

CALIBRATOR

Characteristic	Performance Requirement
Waveshape	Square wave
Polarity	Positive going with baseline at zero volts
Output Voltage	0.1 volt or 1 volt, peak to peak
Output Current	5-milliamperes through PROBE LOOP on side panel
Repetition Rate	1 kHz

Specifications—Type 453/R453

Characteristic	Performance Requirement	
Voltage Accuracy	0° C to +40° C	-15° C to +55° C
	±1%	±1.5%
Current Accuracy	±1%	±1.5%
Repetition Rate Accuracy	±0.5%	±1%
Risetime	Less than 1 microsecond	
Duty Cycle	49% to 51%	
Output Resistance	Approximately 200 ohms in 1 V position Approximately 20 ohms in 0.1 V position	

Z AXIS INPUT

Characteristic	Performance Requirement
Sensitivity	5 volt peak to peak signal produces noticeable modulation
Usable Frequency Range	DC to greater than 50 MHz
Input Resistance at DC	Approximately 47 kilohms
Input Coupling	DC coupled
Polarity of Operation	Positive-going input signal decreases trace intensity Negative-going input signal increases trace intensity
Maximum Input Voltage	200 volts combined DC and peak AC

OUTPUT SIGNALS

Characteristic	Performance Requirement
A and B Gate Waveshape	Rectangular pulse
Amplitude	12 volts peak, ±10%
Polarity	Positive-going with baseline at about -0.7 volts
Duration	Same duration as the respective sweep
Output Resistance	Approximately 1.5 kilohms
Vertical Signal Out (CH 1 only) Output Voltage	25 millivolts, or greater/division of CRT display into 1 megohm load
Bandwidth	DC to 25 MHz or greater when cascaded with Channel 2 or into 50-ohm load
Output coupling	DC coupled
Output resistance	Approximately 50 ohms

POWER SUPPLY

Characteristic	Performance Requirement
Line Voltage	115 volts nominal or 230 volts nominal
Voltage Ranges (AC, RMS) 115-volts nominal	90 to 110 volts 104 to 126 volts 112 to 136 volts

Characteristic	Performance Requirement
230-volts nominal	180 to 220 volts 208 to 252 volts 224 to 272 volts
Line Frequency	48 to 440 Hz
Maximum Power Consumption at 115 volts, 60 Hz	92 watts (105 volt-amperes)

CATHODE-RAY TUBE (CRT)

Characteristic	Performance Requirement
Tube Type	Tektronix T4530-31-1 rectangular
Phosphor	P31 standard. Others available on special order.
Accelerating Potential	Approximately 10 kV total
Graticule Type	Internal
Area	Six divisions vertical by 10 divisions horizontal. Each division equals 0.8 centimeter.
Illumination	Variable edge lighting
Unblanking	Bias-type, DC coupled to CRT grid.
Raster Distortion	0.1 division or less total.
Trace Finder	Limits display within graticule area when pressed.

ENVIRONMENTAL

The following environmental test limits apply when tested in accordance with the recommended test procedure. This instrument will meet the electrical characteristics given in this section following environmental test. Complete details on environmental test procedures, including failure criteria, etc., may be obtained from Tektronix, Inc. Contact your local Tektronix Field Office or representative.

Characteristic	Performance Requirement
Temperature Operating	-15° C to +55° C
Non-operating	-55° C to +75° C
Altitude Operating	15,000 feet maximum
Non-operating	50,000 feet maximum
Humidity Operating and storage	Five cycles (120 hours) to 95% relative humidity referenced to Mil-E-16400F.
Vibration Operating and non-operating	15 minutes along each of the three major axes at a total displacement of 0.025-inch peak to peak (4 g at 55 c/s) with frequency varied from 10-55-10 c/s in one-minute cycles. Hold at 55 c/s for three minutes on each axis.
Shock Operating and non-operating	Two shocks at 30 g, one-half sine, 11 millisecond duration each direction along each major axis. Guillotine-type shocks. Total of 12 shocks.

Specifications—Type 453/R453

Characteristic	Performance Requirement
Transportation Package vibration	Meets National Safe Transit type of test when packaged as shipped from Tektronix, Inc. One hour vibration slightly in excess of 1 g.
Package drop Type 453	30-inch drop on any corner, edge or flat surface.
Type R453	18-inch drop on any corner, edge or flat surface.

MECHANICAL

Characteristic	Information
Construction	
Chassis	Aluminum alloy
Panel	Aluminum alloy with anodized finish
Cabinet	Blue vinyl-coated aluminum
Circuit boards	Glass-epoxy laminate
Overall Dimensions, Type 453 (measured at maximum points)	
Height	7 $\frac{1}{4}$ inches
Width	12 $\frac{1}{2}$ inches
Length	20 $\frac{1}{2}$ inches (includes front cover); 22 $\frac{3}{8}$ inches with handle positioned for carrying.

Characteristic	Performance Requirement
Overall Dimensions, Type R453 (measured at maximum points)	
Height	7 inches
Width	19 inches
Length	17 $\frac{3}{4}$ inches behind front panel; 19 $\frac{9}{16}$ inches overall
Connectors	
Z AXIS INPUT	Binding post
All other connectors	BNC
Net weight	
Type 453 (includes front cover without accessories)	Approximately 29 pounds.
Type R453 (without accessories)	Approximately 32 pounds.

STANDARD ACCESSORIES

Standard accessories supplied with the Type 453 and R453 are listed on the last pullout page of the Mechanical Parts List illustrations. For optional accessories available for use with this instrument, see the current Tektronix, Inc. catalog.

SECTION 2

OPERATING INSTRUCTIONS

Change information, if any, affecting this section is found at the rear of the manual.

General

To effectively use the Type 453, the operation and capabilities of the instrument must be known. This section describes the operation of the front-, side- and rear-panel controls and connectors, gives first time and general operating information and lists some basic applications for this instrument.

Front Cover and Handle

The front cover furnished with the Type 453 provides a dust-tight seal around the front panel. Use the cover to protect the front panel when storing or transporting the instrument. The cover also provides storage space for probes and other accessories (see Fig. 2-1).

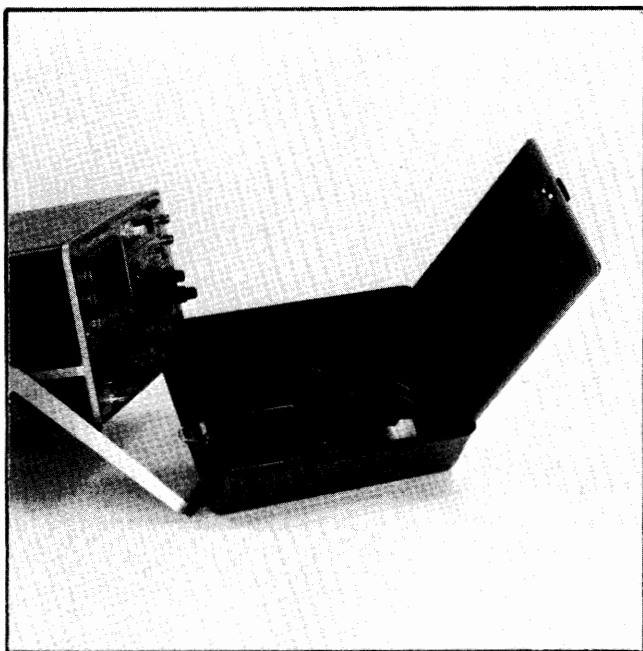

Fig. 2-1. Accessory storage provided in front cover.

The handle of the Type 453 can be positioned for carrying or as a tilt-stand for the instrument. To position the handle, press in at both pivot points (see Fig. 2-2) and turn the handle to the desired position. Several positions are provided for convenient carrying or viewing. The instrument may also be set on the rear-panel feet for operation or storage.

Operating Voltage

The Type 453 can be operated from either a 115-volt or a 230-volt nominal line-voltage source. The Line Voltage

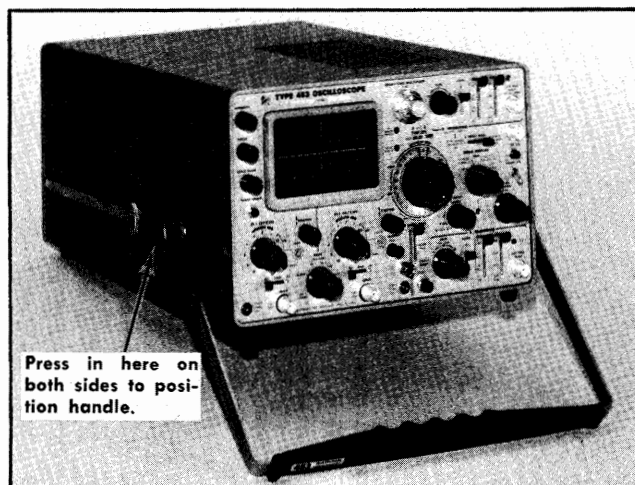

Fig. 2-2. Handle positioned to provide a stand for the instrument.

Selector assembly on the rear panel converts the instrument from one operating range to the other. In addition, this assembly changes the primary connections of the power transformer to allow selection of one of three regulating ranges. The assembly also includes the two line fuses. When the instrument is converted from 115-volt to 230-volt nominal operation, or vice versa, the assembly connects or disconnects one of the fuses to provide the correct protection for the instrument. Use the following procedure to convert this instrument between nominal line voltages or regulating ranges.

1. Disconnect the instrument from the power source.
2. Loosen the two captive screws which hold the cover onto the voltage selector assembly; then pull to remove the cover.
3. To convert from 115-volts nominal to 230-volts nominal line voltage, pull out the Voltage Selector switch bar (see Fig. 2-3); turn it around 180° and plug it back into the remaining holes. Change the line-cord power plug to match the power-source receptacle or use a 115- to 230-volt adapter.
4. To change regulating ranges, pull out the Range Selector switch bar (see Fig. 2-3); slide it to the desired position and plug it back in. Select a range which is centered about the average line voltage to which the instrument is to be connected (see Table 2-1).
5. Re-install the cover and tighten the two captive screws.
6. Before applying power to the instrument, check that the indicating tabs on the switch bars are protruding through the correct holes for the desired nominal line voltage and regulating range.

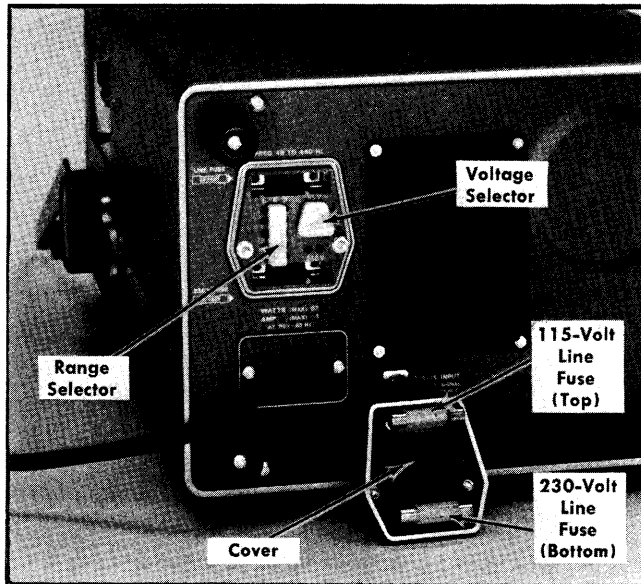

Fig. 2-3. Line Voltage Selector assembly on the rear panel (shown with cover removed).

CAUTION

The Type 453 should not be operated with the Voltage Selector or Range Selector switches in the wrong positions for the line voltage applied. Operation of the instrument with the switches in the wrong positions may either provide incorrect operation or damage the instrument.

TABLE 2-1

Regulating Ranges

Range Selector Switch Position	Regulating Range	
	115-Volts Nominal	230-Volts Nominal
LO (switch bar in left holes)	90 to 110 volts	180 to 220 volts
M (switch bar in middle holes)	104 to 126 volts	208 to 252 volts
HI (switch bar in right holes)	112 to 136 volts	224 to 272 volts

Operating Temperature

The Type 453 is cooled by air drawn in at the rear and blown out through holes in the top and bottom covers. Adequate clearance on the top, bottom and rear must be provided to allow heat to be dissipated away from the instrument. The clearance provided by the feet at the bottom and rear should be maintained. If possible, allow about one inch of clearance on the top. Do not block or restrict the air flow from the air-escape holes in the cabinet.

A thermal cutout in this instrument provides thermal protection and disconnects the power to the instrument if the internal temperature exceeds a safe operating level. Operation of the instrument for extended periods without the covers may cause it to overheat and the thermal cutout to open

more frequently. The air filter should be cleaned occasionally to allow the maximum amount of cooling air to enter the instrument. Cleaning instructions are given in Section 4.

The Type 453 can be operated where the ambient air temperature is between -15°C and $+55^{\circ}\text{C}$. Derate the maximum operating temperature 1°C for each additional 1000 feet of altitude above 5000 feet. This instrument can be stored in ambient temperatures between -55°C and $+75^{\circ}\text{C}$. After storage at temperatures beyond the operating limits, allow the chassis temperature to come within the operating limits before power is applied.

Rackmounting

Complete information for mounting the Type R453 in a cabinet rack is given in Section 6 of this manual.

CONTROLS AND CONNECTORS

A brief description of the function or operation of the front-, side- and rear-panel controls and connectors follows (see Fig. 2-4). More detailed information is given in this section under General Operating Information.

Cathode-Ray Tube

- INTENSITY Controls brightness of display.
- FOCUS Provides adjustment for a well-defined display.
- SCALE ILLUM Controls graticule illumination.
- TRACE FINDER Compresses display within graticule area independent of display position or applied signals.

Vertical (both channels except as noted)

- VOLTS/DIV Selects vertical deflection factor (VARIABLE control must be in CAL position for indicated deflection factor).
- VARIABLE Provides continuously variable deflection factor between the calibrated settings of the VOLTS/DIV switch.
- UNCAL Light indicates that the VARIABLE control is not in the CAL position.
- POSITION Controls vertical position of trace.
- GAIN Screwdriver adjustment to set gain of the Vertical Preamp. Line between adjustment and 20 mV VOLTS/DIV position indicates that gain should be set with VOLTS/DIV switch in this position.
- Input Coupling (AC GND DC) Selects method of coupling input signal to Vertical Deflection System.
 - AC: DC component of input signal is blocked. Low frequency limit (-3 dB point) is about 1.6 hertz.
 - GND: Input circuit is grounded (does not ground applied signal).

CRT

B Triggering and External Horizontal

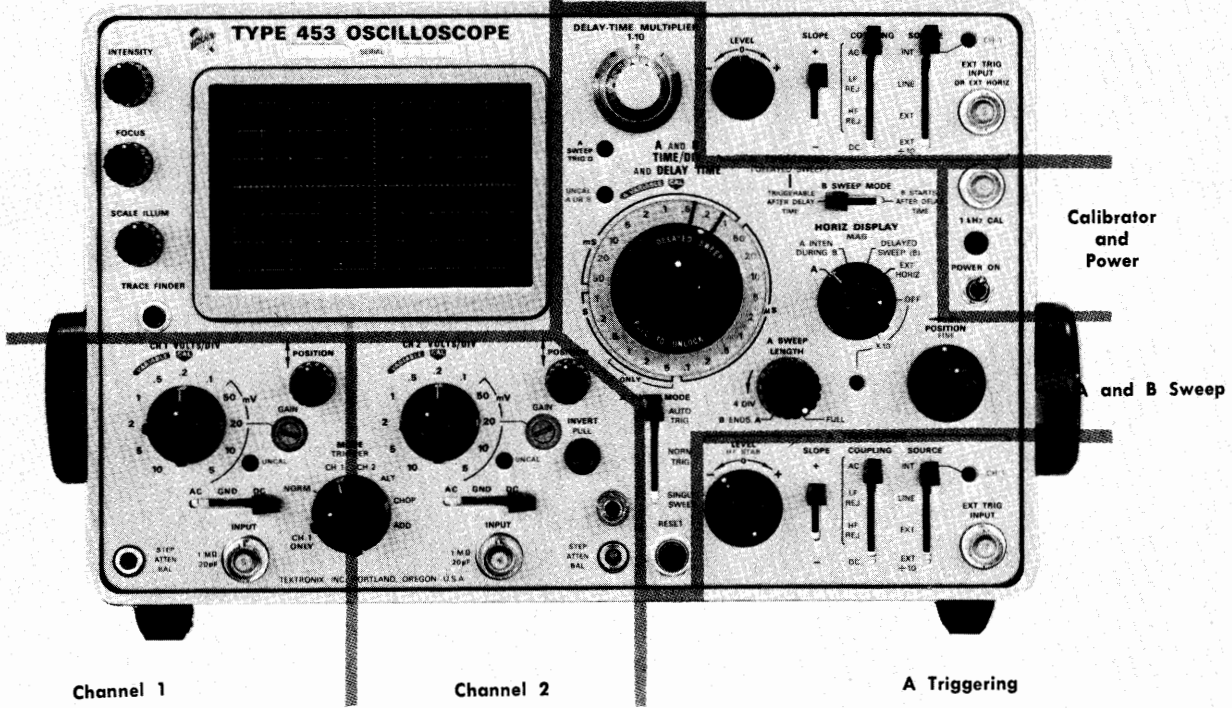

Calibrator and Power

A and B Sweep

Channel 1

Channel 2

A Triggering

A. Front panel

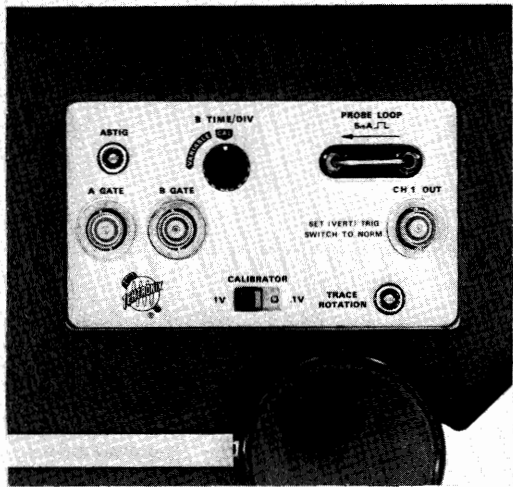

B. Side panel

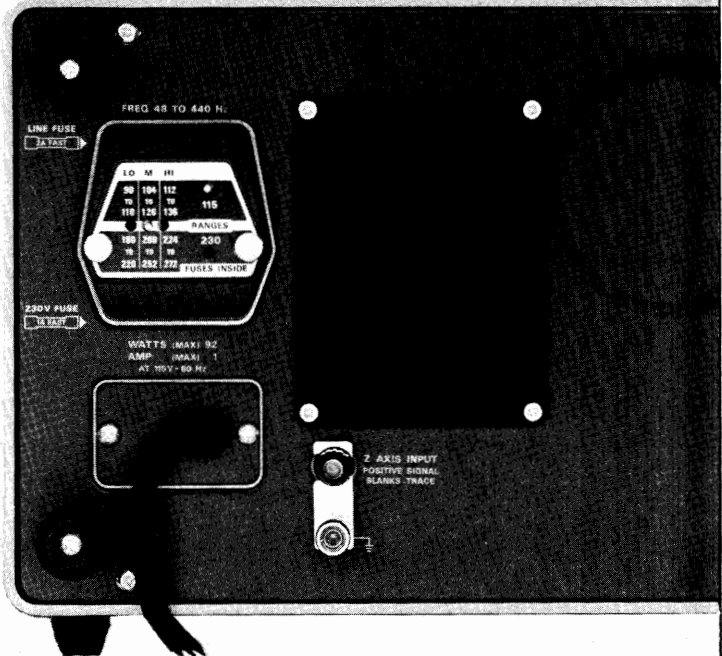

C. Rear panel

Fig. 2-4. Front-, side- and rear-panel controls and connectors.

Operating Instructions—Type 453/R453

	DC: All components of the input signal are passed to the Vertical Deflection System.		EXT: Trigger signal obtained from an external signal applied to the EXT TRIG INPUT connector.
STEP ATTEN BAL	Screwdriver adjustment to balance Vertical Deflection System in the 5, 10 and 20 mV positions of the VOLTS/DIV switch.		EXT ÷ 10: Attenuates external trigger signal approximately 10 times.
INPUT	Vertical input connector for signal.	CH 1	Light indicates that the internal trigger signal is obtained only from the signal connected to the Channel 1 INPUT connector (see TRIGGER switch).
MODE	Selects vertical mode of operation. CH 1: The Channel 1 signal is displayed. CH 2: The Channel 2 signal is displayed. ALT: Dual trace display of signal on both channels. Display switched at end of each sweep. CHOP: Dual trace display of signal on both channels. Approximately one-microsecond segments from each channel displayed at a repetition rate of about 500 kilohertz. ADD: Channel 1 and 2 signals are algebraically added and the algebraic sum is displayed on the CRT.	COUPLING	Determines method of coupling trigger signal to trigger circuit. AC: Rejects DC and attenuates signals below about 30 hertz. Accepts signals between about 30 hertz and 50 megahertz. LF REJ: Rejects DC and attenuates signals below about 30 kilohertz. Accepts signals between about 30 kilohertz and 50 megahertz. HF REJ: Accepts signals between about 30 hertz and 50 kilohertz; rejects DC and attenuates signals outside the above range.
TRIGGER	Selects source of internal trigger signal from vertical system. NORM: Sweep circuits triggered from displayed channel(s). Channel 1 signal available at CH 1 OUT connector. CH 1 ONLY: Sweep circuits triggered only from signal applied to the Channel 1 INPUT connector. No signal available at CH 1 OUT connector. CH 1 lights, located beside A and B SOURCE switches indicate when the TRIGGER switch is in the CH 1 ONLY position.		DC: Accepts all trigger signals from DC to 50 megahertz or greater.
INVERT (CH 2 only)	Inverts the Channel 2 signal when pulled out.	SLOPE	Selects portion of trigger signal which starts the sweep. +: Sweep can be triggered from positive-going portion of trigger signal. -: Sweep can be triggered from negative-going portion of trigger signal.
A and B Triggering (both where applicable)		LEVEL	Selects amplitude point on trigger signal at which sweep is triggered.
EXT TRIG INPUT	Input connector for external trigger signal. Connector in B Triggering section of front panel also serves as external horizontal input when HORIZ DISPLAY switch is in EXT HORIZ position and B SOURCE switch is in EXT position.	HF STAB (A Triggering only)	Decreases display jitter for high-frequency signals. Has negligible effect at lower sweep rates.
SOURCE	Selects source of trigger signal. INT: Internal trigger signal obtained from Vertical Deflection System. When CH 1 light is on, trigger signal is obtained only from the Channel 1 input signal; when the light is off, the trigger signal is obtained from the displayed channel(s). Source of internal trigger signal is selected by the TRIGGER switch. LINE: Trigger signal obtained from a sample of the line voltage applied to this instrument.	A and B Sweep	
		DELAY-TIME MULTIPLIER	Provides variable sweep delay between 0.20 and 10.20 times the delay time indicated by the A TIME/DIV switch.
		A SWEEP TRIG'D	Light indicates that A sweep is triggered and will produce a stable display with correct INTENSITY and POSITION control settings.
		UNCAL A OR B	Light indicates that either the A or B VARIABLE control is not in the CAL position.
		A AND B TIME/DIV AND DELAY TIME	A TIME/DIV switch (clear plastic flange) selects the sweep rate of the A sweep circuit for A sweep only operation and selects the basic delay time (to be multiplied by DELAY-TIME MULTIPLIER dial setting) for delayed sweep operation. B TIME/DIV (DELAYED SWEEP) switch selects sweep rate of the B sweep circuit

	for delayed sweep operation only. VARIABLE controls must be in CAL positions for calibrated sweep rates.		
A VARIABLE	Provides continuously variable A sweep rate to at least 2.5 times setting of the A TIME/DIV switch. A sweep rate is calibrated when control is set fully clockwise to CAL.	RESET	When the RESET button is pressed (SINGLE SWEEP mode), a single display will be presented (with correct triggering) when the next trigger pulse is received. RESET light (inside RESET button) remains on until a trigger is received and the sweep is completed. RESET button must be pressed before another sweep can be presented.
B SWEEP MODE	Selects B sweep operation mode. TRIGGERABLE AFTER DELAY TIME: B sweep circuit will not produce a sweep until a trigger pulse is received following the delay time selected by the DELAY TIME (A TIME/DIV) switch and the DELAY-TIME MULTIPLIER dial. B STARTS AFTER DELAY TIME: B sweep circuit runs immediately following delay time selected by the DELAY TIME switch and DELAY-TIME MULTIPLIER dial.	A SWEEP LENGTH	Adjusts length of A sweep. In the FULL position (clockwise detent), the sweep is about 11 divisions long. As the control is rotated counterclockwise, the length of A sweep is reduced until it is less than four divisions long just before the detent in the fully-counterclockwise position is reached. In the B ENDS A position (counterclockwise detent), the A sweep is reset at the end of the B sweep to provide the fastest possible sweep repetition rate for delayed sweep displays.
HORIZ DISPLAY	Selects horizontal mode of operation. A: Horizontal deflection provided by A sweep. B sweep inoperative. A INTEN DURING B: Sweep rate determined by A TIME/DIV switch. An intensified portion appears on the sweep during the B sweep time. This position provides a check of the duration and position of the delayed sweep (B) with respect to the delaying sweep (A). DELAYED SWEEP (B): Sweep rate determined by B TIME/DIV switch with the delay time determined by the setting of the DELAY TIME (A TIME/DIV) switch and the DELAY-TIME MULTIPLIER dial. Sweep mode determined by B SWEEP MODE switch. EXT HORIZ: Horizontal deflection provided by an external signal.	POSITION	Controls horizontal position of trace.
MAG	Increases sweep rate to ten times setting of A or B TIME/DIV switch by horizontally expanding the center division of the display. Light indicates when magnifier is on.	FINE	Provides more precise horizontal position adjustment.
A SWEEP MODE	Determines the operating mode for A sweep. AUTO TRIG: Sweep initiated by the applied trigger signal using the A Triggering controls when the trigger signal repetition rate is above about 20 hertz. For lower repetition rates or when there is no trigger signal, the sweep free runs at the sweep rate selected by the A TIME/DIV switch to produce a bright reference trace. NORM TRIG: Sweep initiated by the applied trigger signal using the A Triggering controls. No trace is displayed when there is no trigger signal.	1 kHz CAL	Calibrator output connector.
		POWER ON	Light: Indicates that POWER switch is on and the instrument is connected to a line voltage source. Switch: Controls power to the instrument.
		Side Panel	
		ASTIG	Screwdriver adjustment used in conjunction with the FOCUS control to obtain a well-defined display. Does not require readjustment in normal use.
		B TIME/DIV-VARIABLE	Provides continuously variable sweep rate to at least 2.5 times setting of B TIME/DIV switch. B sweep rate is calibrated when control is set fully clockwise to CAL.
		PROBE LOOP	Current loop providing five-milliampere square-wave current from calibrator circuit.
		A GATE	Output connector providing a rectangular pulse coincident with A sweep.
		B GATE	Output connector providing a rectangular pulse coincident with B sweep.
		CH 1 OUT	Output connector providing a sample of the signal applied to the Channel 1 INPUT connector when the TRIGGER switch is in the NORM position.

Operating Instructions—Type 453/R453

CALIBRATOR	Switch selects output voltage of Calibrator. 1-volt or 0.1-volt square wave available.
TRACE ROTATION	Screwdriver adjustment to align trace with horizontal graticule lines.

Rear Panel

Z AXIS INPUT	Input connector for intensity modulation of the CRT display.
Line Voltage Selector	Switching assembly to select the nominal operating voltage and the line voltage range. The assembly also includes the line fuses. Voltage Selector: Selects nominal operating voltage range (115 V or 230 V). Range Selector: Selects line voltage range (low, medium, high).

HORIZ DISPLAY	A
MAG	OFF
POSITION	Midrange
A SWEEP LENGTH	FULL
A SWEEP MODE	AUTO TRIG
POWER	OFF

Side-Panel Controls

B TIME/DIV VARIABLE	CAL
CALIBRATOR	.1 V

2. Connect the Type 453 to a power source that meets the voltage and frequency requirements of the instrument. If the available line voltage is outside the limits of the Line Voltage Selector assembly position (on rear panel), see Operating Voltage in this section.

3. Set the POWER switch to ON. Allow about five minutes warmup so the instrument reaches a normal operating temperature before proceeding.

FIRST-TIME OPERATION

The following steps will demonstrate the use of the controls and connectors of the Type 453. It is recommended that this procedure be followed completely for familiarization with this instrument.

Setup Information

1. Set the front-panel controls as follows:

CRT Controls

INTENSITY	Counterclockwise
FOCUS	Midrange
SCALE ILLUM	Counterclockwise

Vertical Controls (both channels if applicable)

VOLTS/DIV	20 mV
VARIABLE	CAL
POSITION	Midrange
INPUT COUPLING	DC
MODE	CH 1
TRIGGER	NORM
INVERT	Pushed in

Triggering Controls (both A and B if applicable)

LEVEL	Clockwise (+)
SLOPE	+
COUPLING	AC
SOURCE	INT

Sweep Controls

DELAY-TIME MULTIPLIER	0.20
A and B TIME/DIV	.5 ms
A VARIABLE	CAL
B SWEEP MODE	B STARTS AFTER DELAY TIME

CRT Controls

4. Advance the INTENSITY control until the trace is at the desired viewing level (near midrange).

5. Connect the 1 kHz CAL connector to the Channel 1 INPUT connector with a BNC cable.

6. Turn the A LEVEL control toward 0 until the display becomes stable. Note that the A SWEEP TRIG'D light is on when the display is stable.

7. Adjust the FOCUS control for a sharp, well-defined display over the entire trace length. (If focused display cannot be obtained, see Astigmatism Adjustment in this section.)

8. Disconnect the input signal and move the trace with the Channel 1 POSITION control so it coincides with one of the horizontal graticule lines. If the trace is not parallel with the graticule line, see Trace Alignment Adjustment in this section.

9. Rotate the SCALE ILLUM control throughout its range and notice that the graticule lines are illuminated as the control is turned clockwise (most obvious with mesh or smoke-gray filter installed). Set control so graticule lines are illuminated as desired.

Vertical Controls

10. Change the CH 1 VOLTS/DIV switch from 20 mV to 5 mV. If the vertical position of the trace shifts, see Step Attenuator Balance in this section.

11. Set the CH 1 VOLTS/DIV switch to 20 mV and set the Channel 1 Input Coupling switch to AC. Connect the 1 kHz CAL connector to both the Channel 1 and 2 INPUT connectors with two BNC cables and a BNC T connector.

NOTE

If the BNC cables and BNC T connector are not available, make the following changes in the procedure. Place the BNC jack post (supplied accessory) on the 1 kHz CAL connector and connect the two 10X probes (supplied accessories) to

the Channel 1 and 2 INPUT connectors. Connect the probe tips to the BNC jack post. Set the CALIBRATOR switch (on side-panel) to 1 V.

12. Turn the Channel 1 POSITION control to center the display. The display is a square wave, five divisions in amplitude with about five cycles displayed on the screen. If the display is not five divisions in amplitude, see Vertical Gain Adjustment in this section.

13. Set the Channel 1 Input Coupling switch to GND and position the trace to the center horizontal line.

14. Set the Channel 1 Input Coupling switch to DC. Note that the baseline of the waveform remains at the center horizontal line (ground reference).

15. Set the Channel 1 Input Coupling switch to AC. Note that the waveform is centered about the center horizontal line.

16. Turn the Channel 1 VARIABLE control throughout its range. Note that the UNCAL light comes on when the VARIABLE control is moved from the CAL position (fully clockwise). The deflection should be reduced to about two divisions. Return the VARIABLE control to CAL.

17. Set the MODE switch to CH 2.

18. Turn the Channel 2 POSITION control to center the display. The display will be similar to the previous display for Channel 1. Check Channel 2 step attenuator balance and gain as described in steps 10 through 12. The Channel 2 Input Coupling switch and VARIABLE control operate as described in steps 13 through 16.

19. Set both VOLTS/DIV switches to 50 mV.

20. Set the MODE switch to ALT and position the Channel 1 waveform to the top of the graticule area and the Channel 2 waveform to the bottom of the graticule area. Turn the A TIME/DIV switch throughout its range. Note that the display alternates between channels at all sweep rates.

21. Set the MODE switch to CHOP and the A TIME/DIV switch to 10 μ s. Note the switching between channels as shown by the segmented trace. Set the TRIGGER switch to CH 1 ONLY; the trace should appear more solid, since it is no longer triggered on the between-channel switching transients. Turn the A TIME/DIV switch throughout its range. A dual-trace display is presented at all sweep rates, but unlike ALT, both channels are displayed on each trace on a time-sharing basis. Return the A TIME/DIV switch to .5 ms.

22. Set the MODE switch to ADD. The display should be four divisions in amplitude. Note that either POSITION control moves the display.

23. Pull the INVERT switch. The display is a straight line indicating that the algebraic sum of the two signals is zero (if the Channel 1 and 2 gain is correct).

24. Set either VOLTS/DIV switch to 20 mV. The square-wave display indicates that the algebraic sum of the two signals is no longer zero. Return the MODE switch to CH 1 and both VOLTS/DIV switches to .2 (if using 10 \times probes, set both VOLTS/DIV switches to 20 mV). Push in the INVERT switch.

Triggering

25. Set the CALIBRATOR switch to 1 V. Rotate the A LEVEL control throughout its range. The display free runs at the extremes of rotation. Note that the A SWEEP TRIG'D light is on only when the display is triggered.

26. Set the A SWEEP MODE switch to NORM TRIG. Again rotate the A LEVEL control throughout its range. A display is presented only when correctly triggered. The A SWEEP TRIG'D light operates as in AUTO TRIG. Return the A SWEEP MODE switch to AUTO TRIG.

27. Set the A SLOPE switch to —. The trace starts on the negative part of the square wave. Return the switch to +; the trace starts with the positive part of the square wave.

28. Set the A COUPLING switch to DC. Turn the Channel 1 POSITION control until the display becomes unstable (only part of square wave visible). Return the A COUPLING switch to AC; the display is again stable. Since changing trace position changes DC level, this shows how DC level changes affect DC trigger coupling. Return the display to the center of the screen.

29. Set the MODE switch to CH 2; the display should be stable. Remove the signal connected to Channel 1; the display free runs. Set the TRIGGER switch to NORM; the display is again stable. Note that the CH 1 lights in A and B Triggering go out when the TRIGGER switch is changed to NORM.

30. Connect the Calibrator signal to both the Channel 2 INPUT and A EXT TRIG INPUT connectors. Set the A SOURCE switch to EXT. Operation of the LEVEL, SLOPE and COUPLING controls for external triggering are the same as described in steps 25 through 28.

31. Set the A SOURCE switch to EXT \div 10. Operation is the same as for EXT. Note that the A LEVEL control has less range in this position, indicating trigger signal attenuation. Return the A SOURCE switch to INT.

32. Operation of the B Triggering controls is similar to A Triggering.

Normal and Magnified Sweep

33. Set the A TIME/DIV switch to 5 ms and the MAG switch to \times 10. The display should be similar to that obtained with the A TIME/DIV switch set to .5 ms and the MAG switch to OFF.

34. Turn the horizontal POSITION control throughout its range; it should be possible to position the display across the complete graticule area. Now turn the FINE control. The display moves a smaller amount and allows more precise positioning. Return the A TIME/DIV switch to .5 ms, the MAG switch to OFF and return the start of the trace to the left graticule line.

Delayed Sweep

36. Pull the DELAYED SWEEP knob out and turn it to 50 μ s (DELAY TIME remains at .5 ms). Set the HORIZ DISPLAY switch to A INTEN DURING B. An intensified portion, about one division in length, should be shown at the start of the trace. Rotate the DELAY-TIME MULTIPLIER dial throughout its range; the intensified portion should move along the display.

Operating Instructions—Type 453/R453

37. Set the B SWEEP MODE switch to TRIGGERABLE AFTER DELAY TIME. Again rotate the DELAY-TIME MULTIPLIER dial throughout its range and note that the intensified portion appears to jump between positive slopes of the display. Set the B SLOPE switch to —; the intensified portion begins on the negative slope. Rotate the B LEVEL control; the intensified portion of the display disappears when the B LEVEL control is out of the triggerable range. Return the B LEVEL control to 0.

38. Set the HORIZ DISPLAY switch to DELAYED SWEEP (B). Rotate the DELAY-TIME MULTIPLIER dial throughout its range; about one-half cycle of the waveform should be displayed on the screen (leading edge visible only at high INTENSITY control setting). The display remains stable on the screen, indicating that the B sweep is triggered.

39. Set the B SWEEP MODE switch to B STARTS AFTER DELAY TIME. Rotate the DELAY-TIME MULTIPLIER dial throughout its range; the display moves continuously across the screen as the control is rotated.

40. Rotate the DELAY-TIME MULTIPLIER dial fully counter-clockwise and set the HORIZ DISPLAY switch to A INTEN DURING B. Rotate the A SWEEP LENGTH control counter-clockwise; the length of the display decreases. Set the control to the B ENDS A position; now the display ends after the intensified portion. Rotate the DELAY-TIME MULTIPLIER dial and note that the sweep length increases as the display moves across the screen. Return the A SWEEP LENGTH control to FULL and the HORIZ DISPLAY switch to A.

Single Sweep

41. Set the A SWEEP MODE switch to SINGLE SWEEP. Remove the Calibrator signal from the Channel 2 INPUT connector. Press the RESET button; the RESET light should come on and remain on. Again apply the signal to the Channel 2 INPUT connector; a single trace should be presented and the RESET light should go out. Return the A SWEEP MODE switch to AUTO TRIG.

External Horizontal

42. Connect the Calibrator signal to both the Channel 2 INPUT and EXT HORIZ (B EXT TRIG INPUT) connectors. Set the B SOURCE switch to EXT, B COUPLING switch to DC and the HORIZ DISPLAY switch to EXT HORIZ. Increase the INTENSITY control setting until the display is visible (two dots displayed diagonally). The display should be five divisions vertically and about 3.7 divisions horizontally. Set the B SOURCE switch to EXT \div 10. The display should be reduced ten times horizontally. The display can be positioned horizontally with the horizontal POSITION or FINE control and vertically with the Channel 2 POSITION control.

43. Connect the Calibrator signal to both the Channel 1 and 2 INPUT connectors. Set the TRIGGER switch to CH 1 ONLY and the B SOURCE switch to INT.

44. The display should be five divisions vertically and horizontally. The display can be positioned horizontally with the Channel 1 POSITION control and vertically with the Channel 2 POSITION control.

45. Change the CH 1 VOLTS/DIV switch to .5. The display is reduced to two divisions horizontally. Now set the CH 2 VOLTS/DIV switch to .5. The display is reduced to two divisions vertically.

Trace Finder

46. Set the CH 1 and CH 2 VOLTS/DIV switches to 10 mV. The display is not visible since it exceeds the scan area of the CRT.

47. Press the TRACE FINDER button. Note that the display is returned to the display area. While holding the TRACE FINDER button depressed, increase the vertical and horizontal deflection factors until the display is reduced to about two divisions vertically and horizontally. Adjust the Channel 1 and 2 POSITION controls to center the display about the center lines of the graticule. Release the TRACE FINDER and note that the display remains within the viewing area. Disconnect the applied signal.

48. Reduce the INTENSITY control setting to normal, B SOURCE switch to INT and set the HORIZ DISPLAY switch to A.

Z-Axis Input

49. If an external signal is available (five volts peak to peak minimum) the function of the Z AXIS INPUT circuit can be demonstrated. Connect the external signal to both the Channel 2 INPUT connector and the Z AXIS INPUT binding posts. Set the A TIME/DIV switch to display about five cycles of the waveform. The positive peaks of the waveform should be blanked and the negative peaks intensified, indicating intensity modulation.

50. This completes the basic operating procedure for the Type 453. Instrument operation not explained here, or operations which need further explanation are discussed under General Operating Information.

CONTROL SETUP CHART

Fig. 2-5 shows the front, side and rear panels of the Type 453. This chart can be reproduced and used as a test-setup record for special measurements, applications or procedures, or it may be used as a training aid for familiarization with this instrument.

GENERAL OPERATING INFORMATION

Intensity Control

The setting of the INTENSITY control may affect the correct focus of the display. Slight readjustment of the FOCUS control may be necessary when the intensity level is changed. To protect the CRT phosphor, do not turn the INTENSITY control higher than necessary to provide a satisfactory display. The light filters reduce the observed light output from the CRT. When using these filters, avoid advancing the INTENSITY control to a setting that may burn the phosphor. When the highest intensity display is desired, remove the filters and use the clear faceplate protector. Also, be careful that the INTENSITY control is not set too high when changing the TIME/DIV switch from a fast to a slow sweep rate, or when changing the HORIZ DISPLAY switch from EXT HORIZ operation to the normal sweep mode.

Astigmatism Adjustment

If a well-defined trace cannot be obtained with the FOCUS control, adjust the ASTIG adjustment (side panel) as follows.

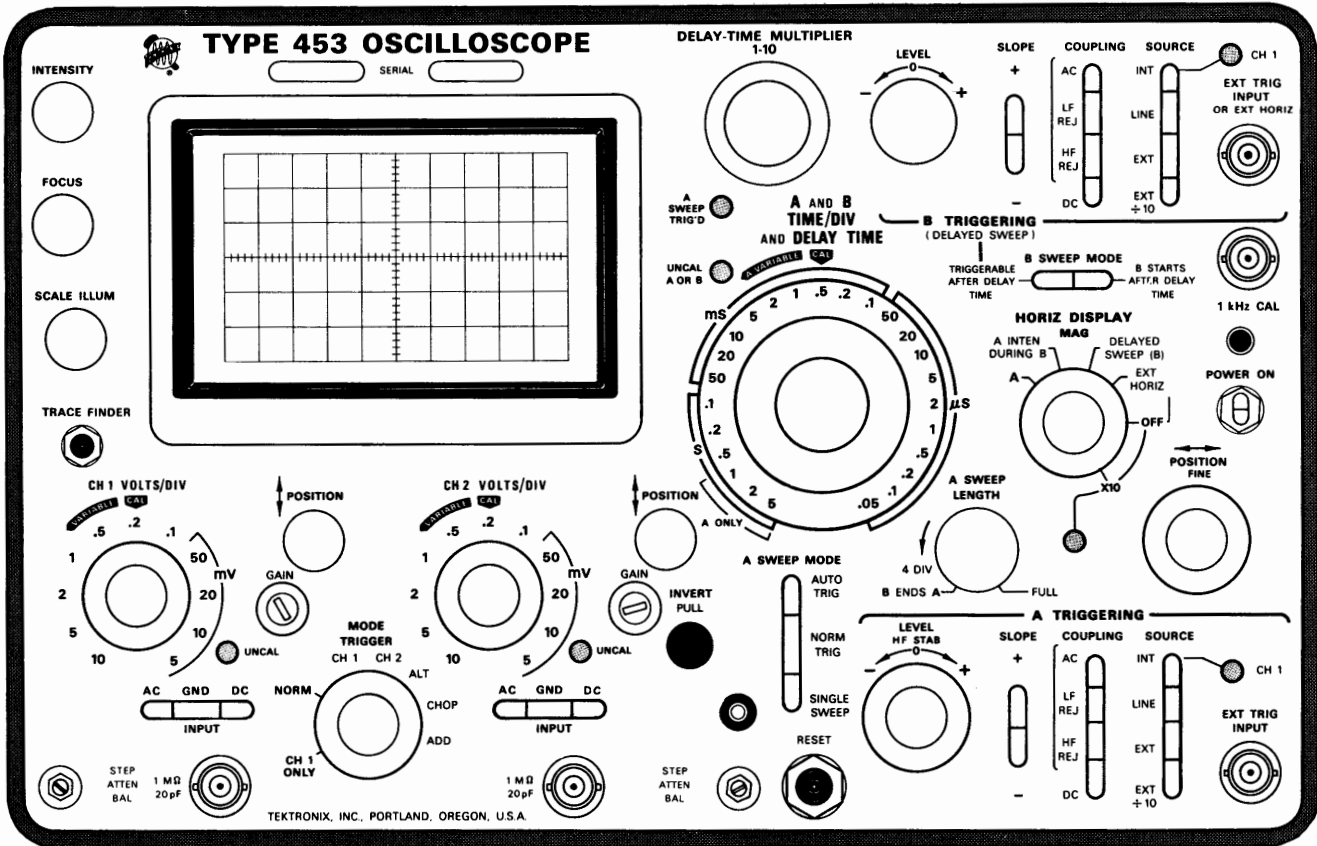

A. Front panel

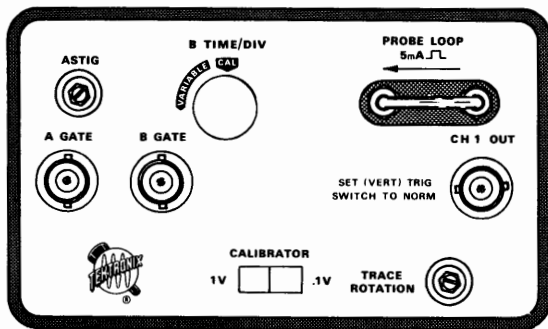

B. Side panel

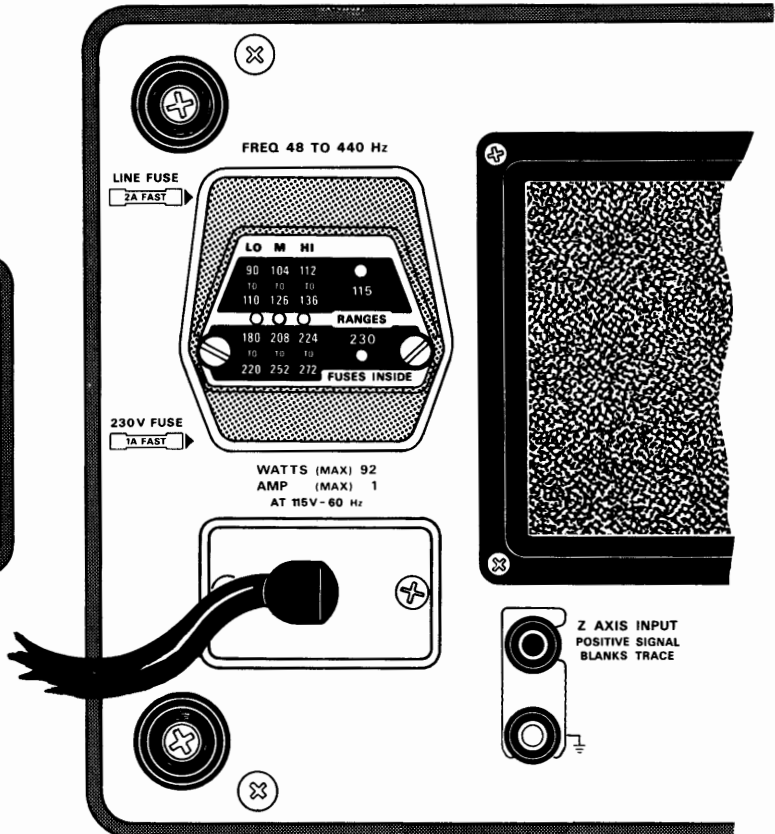

C. Rear panel

Fig. 2-5. Control setup chart for the Type 453.

NOTE

To check for proper setting of the ASTIG adjustment, slowly turn the FOCUS control through the optimum setting. If the ASTIG adjustment is correctly set, the vertical and horizontal portions of the trace will come into sharpest focus at the same position of the FOCUS control. This setting of the ASTIG adjustment should be correct for any display. However, it may be necessary to reset the FOCUS control slightly when the INTENSITY control is changed.

1. Connect a 1 V Calibrator signal to either channel and set the VOLTS/DIV switch of that channel to present a two-division display. Set the MODE switch to display the channel selected.
2. Set the TIME/DIV switch to .2 ms.
3. With the FOCUS control and ASTIG adjustment set to midrange, adjust the INTENSITY control so the rising portion of the display can be seen.
4. Set the ASTIG adjustment so the horizontal and vertical portions of the display are equally focused, but not necessarily well focused.
5. Set the FOCUS control so the vertical portion of the trace is as thin as possible.
6. Repeat steps 4 and 5 for best overall focus. Make final check at normal intensity.

Graticule

The graticule of the Type 453 is internally marked on the faceplate of the CRT to provide accurate, no-parallax measurements. The graticule is marked with six vertical and 10 horizontal divisions. Each division is 0.8 centimeter square. In addition, each major division is divided into five minor divisions at the center vertical and horizontal lines. The vertical gain and horizontal timing are calibrated to the graticule so accurate measurements can be made from the CRT. The illumination of the graticule lines can be varied with the SCALE ILLUM control.

Fig. 2-6 shows the graticule of the Type 453 and defines the various measurement lines. The terminology defined here will be used in all discussions involving graticule measurements.

Trace Alignment Adjustment

If a free-running trace is not parallel to the horizontal graticule lines, set the TRACE ROTATION adjustment as follows. Position the trace to the center horizontal line. Adjust the TRACE ROTATION adjustment (side panel) so the trace is parallel with the horizontal graticule lines.

Light Filter

The mesh filter provided with the Type 453 provides shielding against radiated EMI (electro-magnetic interference) from the face of the CRT. It also serves as a light filter to make the trace more visible under ambient light conditions. To

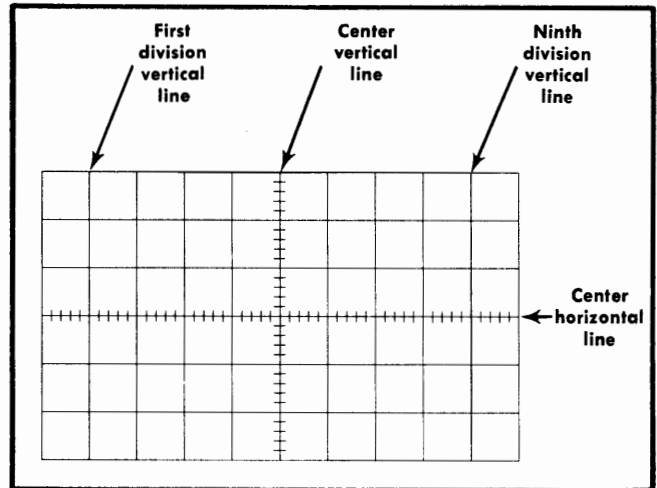

Fig. 2-6. Definition of measurement lines on Type 453 graticule.

remove the filter, press down at the bottom of the frame and pull the top of the filter away from the CRT faceplate (see Fig. 2-7).

The tinted light filter minimizes light reflections from the face of the CRT to improve contrast when viewing the display under high ambient light conditions. A clear plastic faceplate protector is also provided with this instrument for use when neither the mesh nor the tinted filter is used. The clear faceplate protector provides the best display for waveform photographs. It is also preferable for viewing high writing rate displays.

A filter or the faceplate protector should be used at all times to protect the CRT faceplate from scratches. The faceplate protector and the tinted filter mount in the same holder.

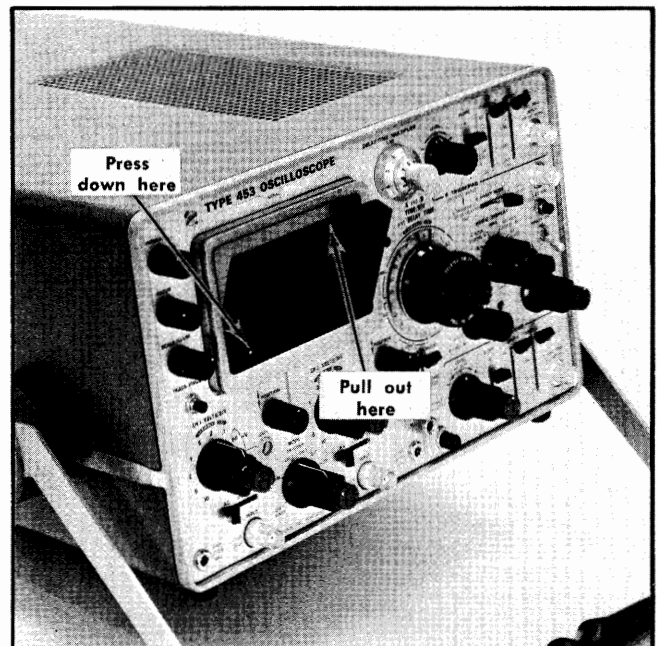

Fig. 2-7. Removing the filter or faceplate protector.

To remove the light filter or faceplate protector from the holder, press it out to the rear. They can be replaced by snapping them back into the holder.

Trace Finder

The TRACE FINDER provides a means of locating a display which overscans the viewing area either vertically or horizontally. When the TRACE FINDER button is pressed, the display is compressed within the graticule area. To locate and reposition an overscanned display, use the following procedure.

1. Press the TRACE FINDER button.
2. While the TRACE FINDER button is held depressed, increase the vertical and horizontal deflection factors until the vertical deflection is reduced to about two divisions and the horizontal deflection is reduced to about four divisions (the horizontal deflection needs to be reduced only when in the external horizontal mode of operation).
3. Adjust the vertical and horizontal POSITION controls to center the display about the vertical and horizontal center lines.
4. Release the TRACE FINDER button; the display should remain within the viewing area.

Vertical Channel Selection

Either of the input channels can be used for single-trace displays. Apply the signal to the desired INPUT connector and set the MODE switch to display the channel used. However, since CH 1 ONLY triggering is provided only in Channel 1 and the invert feature only in Channel 2, the correct channel must be selected to take advantage of these features. For dual-trace displays, connect the signals to both INPUT connectors and set the MODE switch to one of the dual-trace positions.

Vertical Gain Adjustment

To check the gain of either channel, set the VOLTS/DIV switch to 20 mV. Set the CALIBRATOR switch to .1 V and connect the 1 kHz CAL connector to the INPUT of the channel used. The vertical deflection should be exactly five divisions. If not, adjust the front-panel GAIN adjustment for exactly five divisions of deflection.

NOTE

If the gain of the two channels must be closely matched (such as for ADD mode operation), the ADJUSTMENT procedure given in the Calibration section should be used.

The best measurement accuracy when using probes is provided if the GAIN adjustment is made with the probes installed (set the CALIBRATOR switch to 1 V). Also, to provide the most accurate measurements, calibrate the vertical gain of the Type 453 at the temperature at which the measurement is to be made.

Step Attenuator Balance

To check the step attenuator balance of either channel, set the Input Coupling switch to GND and set the A SWEEP

MODE switch to AUTO TRIG to provide a free-running trace. Change the VOLTS/DIV switch from 20 mV to 5 mV. If the trace moves vertically, adjust the front-panel STEP ATTEN BAL adjustment as follows (allow at least 10 minutes warm up before performing this adjustment).

1. With the Input Coupling switch set to GND and the VOLTS/DIV switch set to 20 mV, move the trace to the center horizontal line of the graticule with the vertical POSITION control.
2. Set the VOLTS/DIV switch to 5 mV and adjust the STEP ATTEN BAL adjustment to return the trace to the center horizontal line.
3. Recheck step attenuator balance and repeat adjustment until no trace shift occurs as the VOLTS/DIV switch is changed from 20 mV to 5 mV.

Signal Connections

In general, probes offer the most convenient means of connecting a signal to the input of the Type 453. The Tektronix probes are shielded to prevent pickup of electrostatic interference. A 10× attenuator probe offers a high input impedance and allows the circuit under test to perform very close to normal operating conditions. However, a 10× probe also attenuates the input signal 10 times. The Tektronix P6045 Field Effect Transistor probe and accessory power supply offer the same high-input impedance as the 10× probes. However, it is particularly useful since it provides wide-band operation while presenting no attenuation (1× gain) and a low input capacitance. To obtain maximum bandwidth when using the probes, observe the grounding considerations given in the probe manual. The probe-to-connector adapters and the bayonet-ground tip provide the best frequency response. Remember that a ground strap only a few inches in length can produce several percent of ringing when operating at the higher frequency limit of this system. See your Tektronix, Inc. catalog for characteristics and compatibility of probes for use with this system.

In high-frequency applications requiring maximum overall bandwidth, use coaxial cables terminated at both ends in their characteristic impedance. See the discussion on coaxial cables in this section for more information.

High-level, low-frequency signals can be connected directly to the Type 453 INPUT connectors with short unshielded leads. This coupling method works best for signals below about one kilohertz and deflection factors above one volt/division. When this method is used, establish a common ground between the Type 453 and the equipment under test. Attempt to position the leads away from any source of interference to avoid errors in the display. If interference is excessive with unshielded leads, use a coaxial cable or a probe.

Loading Effect of the Type 453

As nearly as possible, simulate actual operating conditions in the equipment under test. Otherwise, the equipment under test may not produce a normal signal. The 10× attenuator probe and field effect transistor probe mentioned previously offer the least circuit loading. See the probe instruction manual for loading characteristics of the individual probes.

Operating Instructions—Type 453/R453

When the signal is coupled directly to the input of the Type 453, the input impedance is about one megohm paralleled by about 20 pF. When the signal is coupled to the input through a coaxial cable, the effective input capacitance depends upon the type and length of cable used. See the following discussion for information on obtaining maximum frequency response with coaxial cables.

Coaxial Cable Considerations

The signal cables used to connect the signal to the Type 453 INPUT connectors have a large effect on the accuracy of the displayed high-frequency waveform. To maintain the high-frequency characteristics of the applied signal, high-quality low-loss coaxial cable should be used. The cable should be terminated at the Type 453 INPUT connector in its characteristic impedance. If it is necessary to use cables with differing characteristic impedances, use suitable impedance-matching devices to provide the correct transition, with minimum loss, from one impedance to the other.

The characteristic impedance, velocity of propagation and nature of signal losses in a coaxial cable are determined by the physical and electrical characteristics of the cable. Losses caused by energy dissipation in the dielectric are proportional to the signal frequency. Therefore, much of the high-frequency information in a fast-rise pulse can be lost in only a few feet of interconnecting cable if it is not the correct type. To be sure of the high-frequency response of the system when using cables longer than about five feet, observe the transient response of the Type 453 and the interconnecting cable with a fast-rise pulse generator (generator risetime less than 0.5 nanoseconds).

Input Coupling

The Channel 1 and 2 Input Coupling switches allow a choice of input coupling. The type of display desired will determine the coupling used.

The DC position can be used for most applications. However, if the DC component of the signal is much larger than the AC component, the AC position will probably provide a better display. DC coupling should be used to display AC signals below about 16 hertz as they will be attenuated in the AC position.

In the AC position, the DC component of the signal is blocked by a capacitor in the input circuit. The low-frequency response in the AC position is about 1.6 hertz (—3 dB point). Therefore, some low-frequency distortion can be expected near this frequency limit. Distortion will also appear in square waves which have low-frequency components.

The GND position provides a ground reference at the input of the Type 453. The signal applied to the input connector is internally disconnected but not grounded. The input circuit is held at ground potential, eliminating the need to externally ground the input to establish a DC ground reference.

The GND position can also be used to pre-charge the coupling capacitor to the average voltage level of the signal applied to the INPUT connector. This allows measurement of only the AC component of signals having both AC and

DC components. The pre-charging network incorporated in this unit allows the input-coupling capacitor to charge to the DC source voltage level when the Input Coupling switch is set to GND. The procedure for using this feature is as follows:

1. Before connecting the signal containing a DC component to the Type 453 INPUT connector, set the Input Coupling switch to GND. Then connect the signal to the INPUT connector.
2. Wait about one second for the coupling capacitor to charge.
3. Set the Input Coupling switch to AC. The trace (display) will remain on the screen and the AC component of the signal can be measured in the normal manner.

Deflection Factor

The amount of vertical deflection produced by a signal is determined by the signal amplitude, the attenuation factor of the probe (if used), the setting of the VOLTS/DIV switch and the setting of the VARIABLE VOLTS/DIV control. The calibrated deflection factors indicated by the VOLTS/DIV switches apply only when the VARIABLE control is set to the CAL position.

The VARIABLE VOLTS/DIV control provides variable (uncalibrated) vertical deflection between the calibrated settings of the VOLTS/DIV switch. The VARIABLE control extends the maximum vertical deflection factor of the Type 453 to at least 25 volts/division (10 volts position).

Dual-Trace Operation

Alternate Mode. The ALT position of the MODE switch produces a display which alternates between Channel 1 and 2 with each sweep of the CRT. Although the ALT mode can be used at all sweep rates, the CHOP mode provides a more satisfactory display at sweep rates below about 50 microseconds/division. At these slower sweep rates, alternate mode switching becomes visually perceptible.

Proper internal triggering in the ALT mode can be obtained in either the NORM or CH 1 ONLY positions of the TRIGGER switch. When in the NORM position, the sweep is triggered from the signal on each channel. This provides a stable display of two unrelated signals, but does not indicate the time relationship between the signals. In the CH 1 ONLY position, the two signals are displayed showing true time relationship. If the signals are not time related, the Channel 2 waveform will be unstable in the CH 1 ONLY position.

Chopped Mode. The CHOP position of the MODE switch produces a display which is electronically switched between channels. In general, the CHOP mode provides the best display at sweep rates slower than about 50 microseconds/division, or whenever dual-trace, single-shot phenomena are to be displayed. At faster sweep rates the chopped switching becomes apparent and may interfere with the display.

Proper internal triggering for the CHOP mode is provided with the TRIGGER switch set to CH 1 ONLY. If the NORM position is used, the sweep circuits are triggered from the between-channel switching signal and both waveforms will

be unstable. External triggering provides the same result as CH 1 ONLY triggering.

Two signals which are time-related can be displayed in the chopped mode showing true time relationship. If the signals are not time-related, the Channel 2 display will appear unstable. Two single-shot, transient, or random signals which occur within the time interval determined by the TIME/DIV switch (10 times sweep rate) can be compared using the CHOP mode. To correctly trigger the sweep for maximum resolution, the Channel 1 signal must precede the Channel 2 signal. Since the signals show true time relationship, time-difference measurements can be made.

Channel 1 Output and Cascaded Operation

If a lower deflection factor than provided by the VOLTS/DIV switches is desired, Channel 1 can be used as a wide-band preamplifier for Channel 2. Apply the input signal to the Channel 1 INPUT connector. Connect a 50-ohm BNC cable (18-inch or shorter cable for maximum cascaded frequency response) between the CH 1 OUT (side panel) and the Channel 2 INPUT connectors. Set the MODE switch to CH 2 and the TRIGGER switch to NORM. With both VOLTS/DIV switches set to 5 mV, the deflection factor will be less than one millivolt/division.

To provide calibrated one millivolt/division deflection factor, connect the .1 volt Calibrator signal to the Channel 1 INPUT connector. Set the CH 1 VOLTS/DIV switch to .1 and the CH 2 VOLTS/DIV switch to 5 mV. Adjust the Channel 2 VARIABLE VOLTS/DIV control to produce a display exactly five divisions in amplitude. The cascaded deflection factor is determined by dividing the CH 1 VOLTS/DIV switch setting by 5 (CH 2 VOLTS/DIV switch and VARIABLE control remain as set above). For example, with the CH 1 VOLTS/DIV switch set to 5 mV the calibrated deflection factor will be 1 millivolt/division; CH 1 VOLTS/DIV switch set to 10 mV, 2 millivolts/division, etc.

The following operating considerations and basic applications may suggest other uses for this feature.

1. If AC coupling is desired, set the Channel 1 Input Coupling switch to AC and leave the Channel 2 Input Coupling switch set to DC. When both Input Coupling switches are set to DC, DC signal coupling is provided.

2. Keep both vertical POSITION controls set near midrange. If the input signal has a DC level which necessitates one of the POSITION controls being turned away from midrange, correct operation can be obtained by keeping the Channel 2 POSITION control near midrange and using the Channel 1 POSITION control to position the trace near the desired location. Then, use the Channel 2 POSITION control for exact positioning. This method will keep both Input Preamps operating in their linear range.

3. The output voltage at the CH 1 OUT connector is at least 25 millivolts/division of CRT display in all CH 1 VOLTS/DIV switch positions.

4. The MODE switch and Channel 1 VARIABLE VOLTS/DIV control have no effect on the signal available at the CH 1 OUT connector.

5. The Channel 1 Input Preamp can be used as an impedance matching stage with or without voltage gain. The

input resistance is one megohm and the output resistance is about 50 ohms.

6. The dynamic range of the Channel 1 Input Preamp is equal to about 20 times the CH 1 VOLTS/DIV setting. The CH 1 OUT signal is nominally at 0 volt DC for a 0 volt DC input level (Channel 1 POSITION control centered). The Channel 1 POSITION control can be used to center the output signal within the dynamic range of the amplifier.

7. If dual-trace operation is used, the signal applied to the Channel 1 INPUT connector is displayed when Channel 1 is turned on. When Channel 2 is turned on, the amplified signal is displayed. Thus, Channel 1 trace can be used to monitor the input signal while the amplified signal is displayed by Channel 2.

8. In special applications where the flat frequency response of the Type 453 is not desired, a filter inserted between the CH 1 OUT and Channel 2 INPUT connector allows the oscilloscope to essentially take on the frequency response of the filter. Combined with method 7, the input can be monitored by Channel 1 and the filtered signal displayed by Channel 2.

9. By using Channel 1 as a 5× low-level voltage preamplifier (5 mV position), the Channel 1 signal available at the CH 1 OUT connector can be used for any application where a low-impedance preamplified signal is needed. Remember that if a 50-ohm load impedance is used, the signal amplitude will be about one-half.

Algebraic Addition

General. The ADD position of the MODE switch can be used to display the sum or difference of two signals, for common-mode rejection to remove an undesired signal or for DC offset (applying a DC voltage to one channel to offset the DC component of a signal on the other channel).

The common-mode rejection ratio of the Type 453 is greater than 20:1 at 20 megahertz for signal amplitudes up to eight times the VOLTS/DIV switch setting. Rejection ratios of 100:1 can typically be achieved between DC and 5 megahertz by careful adjustment of the gain of either channel while observing the displayed common-mode signal.

Deflection Factor. The overall deflection in the ADD position of the MODE switch when both VOLTS/DIV switches are set to the same position is the same as the deflection factor indicated by either VOLTS/DIV switch. The amplitude of an added mode display can be determined directly from the resultant CRT deflection multiplied by the deflection factor indicated by either VOLTS/DIV switch. However, if the CH 1 and CH 2 VOLTS/DIV switches are set to different deflection factors, resultant voltage is difficult to determine from the CRT display. In this case, the voltage amplitude of the resultant display can be determined accurately only if the amplitude of the signal applied to either channel is known.

Precautions. The following general precautions should be observed when using the ADD mode.

1. Do not exceed the input voltage rating of the Type 453.

Operating Instructions—Type 453/R453

2. Do not apply signals that exceed an equivalent of about 20 times the VOLTS/DIV switch setting. For example, with a VOLTS/DIV switch setting of .5, the voltage applied to that channel should not exceed about 10 volts. Larger voltages may distort the display.

3. Use vertical POSITION control settings which most nearly position the signal of each channel to mid-screen when viewed in either the CH 1 or CH 2 positions of the MODE switch. This insures the greatest dynamic range for ADD mode operation.

4. For similar response from each channel, set both Input Coupling switches to the same position.

Trigger Source

INT. For most applications, the sweep can be triggered internally. In the INT position of the Triggering SOURCE switch, the trigger signal is obtained from the Vertical Deflection System. The TRIGGER switch provides further selection of the internal trigger signal; obtained from the Channel 1 signal in the CH 1 ONLY position, or from the displayed signal when in the NORM position. For single-trace displays of either channel, the NORM position provides the most convenient operation. However, for dual-trace displays special considerations must be made to provide the correct display. Set Dual-Trace Operation in this section for dual-trace triggering information.

LINE. The LINE position of the SOURCE switch connects a sample of the power-line frequency to the Trigger Generator circuit. Line triggering is useful when the input signal is time-related to the line frequency. It is also useful for providing a stable display of a line-frequency component in a complex waveform.

EXT. An external signal connected to the EXT TRIG INPUT connector can be used to trigger the sweep in the EXT position of the Triggering SOURCE switch. The external signal must be time-related to the displayed signal for a stable display. An external trigger signal can be used to provide a triggered display when the internal signal is too low in amplitude for correct triggering, or contains signal components on which it is not desired to trigger. It is also useful when signal tracing in amplifiers, phase-shift networks, wave-shaping circuits, etc. The signal from a single point in the circuit under test can be connected to the EXT TRIG INPUT connector through a signal probe or cable. The sweep is then triggered by the same signal at all times and allows amplitude, time relationship or waveshape changes of signals at various points in the circuit to be examined without resetting the trigger controls.

EXT ÷ 10. Operation in the EXT ÷ 10 position is the same as described for EXT except that the external triggering signal is attenuated 10 times. Attenuation of high-amplitude external triggering signals is desirable to broaden the range of the Triggering LEVEL control. When the COUPLING switch is set to LF REJ, attenuation is about 20:1.

Trigger Coupling

Four methods of coupling the trigger signal to the trigger circuits can be selected with the Triggering COUPLING switches. Each position permits selection or rejection of the

frequency components of the trigger signal which can trigger the sweep.

AC. The AC position blocks the DC component of the trigger signal. Signals with low-frequency components below about 30 hertz are attenuated. In general, AC coupling can be used for most applications. However, if the trigger signal contains unwanted components or if the sweep is to be triggered at a low repetition rate or a DC level, one of the remaining COUPLING switch positions will provide a better display.

The triggering point in the AC position depends on the average voltage level of the trigger signal. If the trigger signals occur in a random fashion, the average voltage level will vary, causing the triggering point to vary also. This shift of the triggering point may be enough so it is impossible to maintain a stable display. In such cases, use DC coupling.

LF REJ. In the LF REJ position, DC is rejected and signals below about 30 kilohertz are attenuated. Therefore, the sweep will be triggered only by the higher-frequency components of the signal. This position is particularly useful for providing stable triggering if the trigger signal contains line-frequency components. Also, in the ALT position of the MODE switch, the LF REJ position provides the best display at high sweep rates when comparing two unrelated signals (TRIGGER switch set to NORM).

HF REJ. The HF REJ position passes all low-frequency signals between about 30 hertz and 50 kilohertz. DC is rejected and signals outside the given range are attenuated. When triggering from complex waveforms, this position is useful for providing stable display of low-frequency components.

DC. DC coupling can be used to provide stable triggering with low-frequency signals which would be attenuated in the AC position, or with low-repetition rate signals. The LEVEL control can be adjusted to provide triggering at the desired DC level on the waveform. When using internal triggering, the setting of the Channel 1 and 2 POSITION controls affects the DC trigger level.

DC trigger coupling should not be used in the ALT dual-trace mode if the TRIGGER switch is set to NORM. If used, the sweep will trigger on the DC level of one trace and then either lock out completely or free run on the other trace. Correct DC triggering for this mode can be obtained with the TRIGGER switch set to CH 1 ONLY.

Trigger Slope

The triggering SLOPE switch determines whether the trigger circuit responds on the positive-going or negative-going portion of the trigger signal. When the SLOPE switch is in the + (positive-going) position, the display starts with the positive-going portion of the waveform; in the — (negative-going) position, the display starts with the negative-going portion of the waveform (see Fig. 2-8). When several cycles of a signal appear in the display, the setting of the SLOPE switch is often unimportant. However, if only a certain portion of a cycle is to be displayed, correct setting of the SLOPE switch is important to provide a display which starts on the desired slope of the input signal.

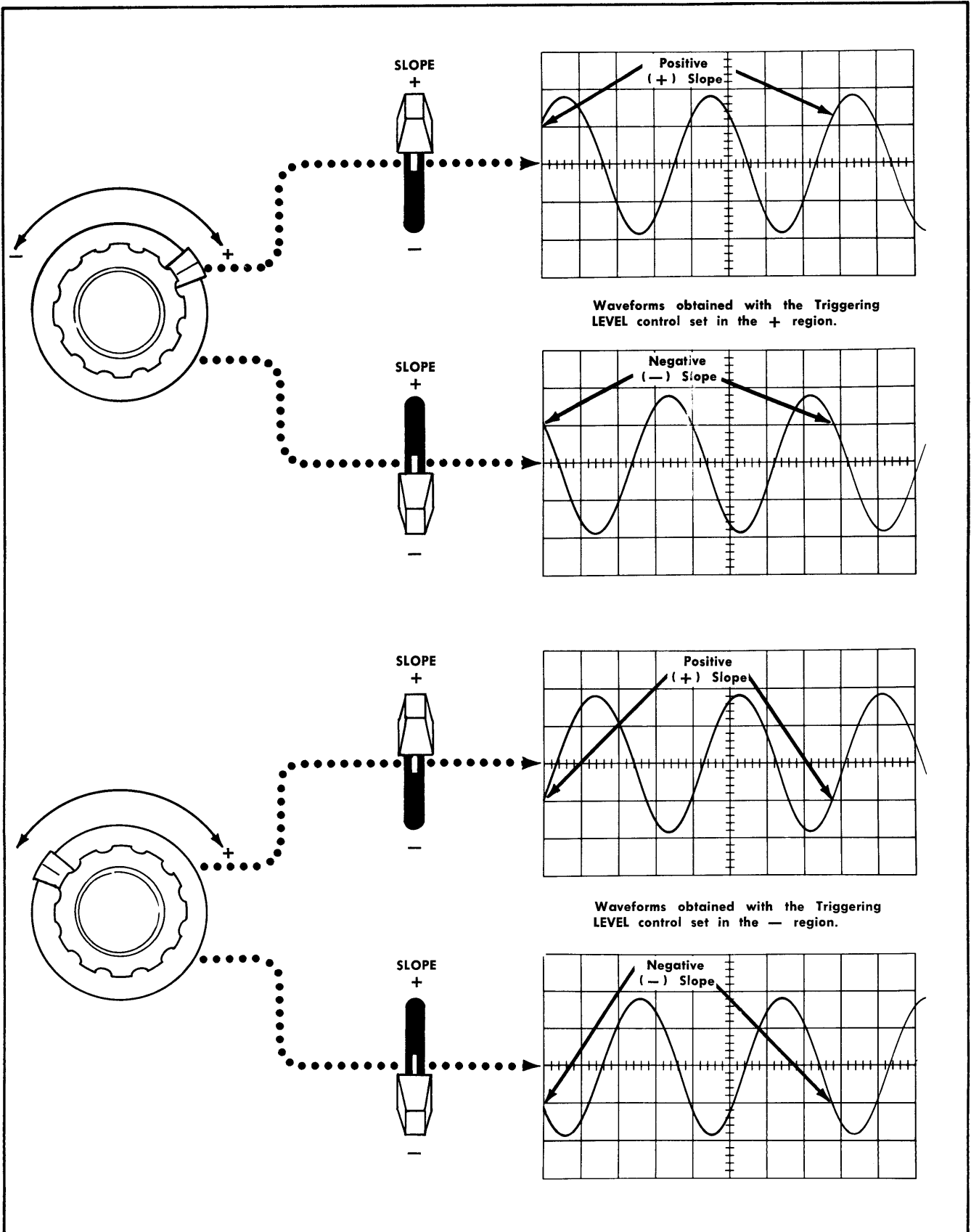

Fig. 2-8. Effects of Triggering LEVEL control and SLOPE switch.

Trigger Level

The Triggering LEVEL control determines the voltage level on the trigger signal at which the sweep is triggered. When the LEVEL control is set in the + region, the trigger circuit responds at a more positive point on the trigger signal. When the LEVEL control is set in the — region, the trigger circuit responds at a more negative point on the trigger signal. Fig. 2-8 illustrates this effect with different settings of the SLOPE switch.

To set the LEVEL control, first select the Triggering SOURCE, COUPLING and SLOPE. Then set the LEVEL control fully counterclockwise and rotate it clockwise until the display starts at the desired point.

High-Frequency Stability

The HF STAB control (A only) is used to provide a stable display of high-frequency signals. If a stable display cannot be obtained using the A LEVEL control (trigger signal must have adequate amplitude), adjust the HF STAB control for minimum horizontal jitter in the display. This control has little effect with low-frequency signals.

A Sweep Triggered Light

The A SWEEP TRIG'D light provides a convenient indication of the condition of the A Triggering circuit. If the A Triggering controls are correctly adjusted with an adequate trigger signal applied, the light is on. However, if the A LEVEL control is misadjusted, the A COUPLING or A SOURCE switches incorrectly set or the trigger signal too low in amplitude, the A SWEEP TRIG'D light will be off. This feature can be used as a general indication of correct triggering. It is particularly useful when setting up the trigger circuits when a trigger signal is available without a trace displayed on the CRT and it also indicates that the A sweep is correctly triggered when operating in the DELAYED SWEEP (B) mode.

A Sweep Mode

AUTO TRIG. The AUTO TRIG position of the A SWEEP MODE switch provides a stable display when the A LEVEL control is correctly set (see Trigger Level in this section) and a trigger signal is available. The A SWEEP TRIG'D light indicates when the A Sweep Generator is triggered.

When the trigger repetition rate is less than about 20 hertz, or in the absence of an adequate trigger signal, the A Sweep Generator free runs to produce a reference trace. When an adequate trigger signal is again applied, the free-running condition ends and the A Sweep Generator is triggered to produce a stable display (with correct A LEVEL control setting).

NORM TRIG. Operation in the NORM TRIG position when a trigger signal is applied is the same as in the AUTO TRIG position. However, when a trigger signal is not present, the A Sweep Generator remains off and there is no display. The A SWEEP TRIG'D light indicates when the A sweep is triggered. The NORM TRIG mode can be used to display

signals with repetition rates below about 20 hertz. This mode provides an indication of an adequate trigger signal as well as the correctness of trigger control settings, since there is no display without proper triggering. Also, the A SWEEP TRIG'D light is off when the A sweep is not correctly triggered.

SINGLE SWEEP. When the signal to be displayed is not repetitive or varies in amplitude, shape or time, a conventional repetitive display may produce an unstable presentation. To avoid this, use the single-sweep feature of the Type 453. The SINGLE SWEEP mode can also be used to photograph a non-repetitive signal.

To use the SINGLE SWEEP mode, first make sure the trigger circuit will respond to the event to be displayed. Set the A SWEEP MODE switch to AUTO TRIG or NORM TRIG and obtain the best possible display in the normal manner (for random signals set the trigger circuit to trigger on a signal which is approximately the same amplitude and frequency as the random signal). Then, set the A SWEEP MODE switch to SINGLE SWEEP and press the RESET button. When the RESET button is pushed, the next trigger pulse initiates the sweep and a single trace will be presented on the screen. After this sweep is complete, the A Sweep Generator is "locked out" until reset. The RESET light located inside the RESET button lights when the A Sweep Generator circuit has been reset and is ready to produce a sweep; it goes out after the sweep is complete. To prepare the circuit for another single-sweep display, press the RESET button again.

Selecting Sweep Rate

The A AND B TIME/DIV switches select calibrated sweep rates for the Sweep Generators. The A and B VARIABLE controls provide continuously variable sweep rates between the settings of the TIME/DIV switches. Whenever the UNCAL A OR B light is on, the sweep rate of either A or B Sweep Generator, or both, is uncalibrated. The light is off when the A VARIABLE (front panel) and B TIME/DIV VARIABLE (side panel) controls are both set to the CAL position.

The sweep rate of the A Sweep Generator is bracketed by the two black lines on the clear plastic flange of the TIME/DIV switch (see Fig. 2-9). The B Sweep Generator sweep rate is indicated by the dot on the DELAYED SWEEP knob. When the dot on the outer knob is set to the same position as the lines on the inner knob, the two knobs lock together and the sweep rate of both Sweep Generators is changed at the same time. However, when the DELAYED SWEEP knob is pulled outward, the clear plastic flange is disengaged and only the B Sweep Generator sweep rate is changed. This allows changing the delayed sweep rate without changing the delay time determined by the A Sweep Generator.

When making time measurements from the graticule, the area between the first-division and ninth-division vertical lines provides the most linear time measurement (see Fig. 2-10). Therefore, the first and last division of the display should not be used for making accurate time measurements. Position the start of the timing area to the first-division vertical line and set the TIME/DIV switch so the end of the timing area falls between the first- and ninth-division vertical lines.

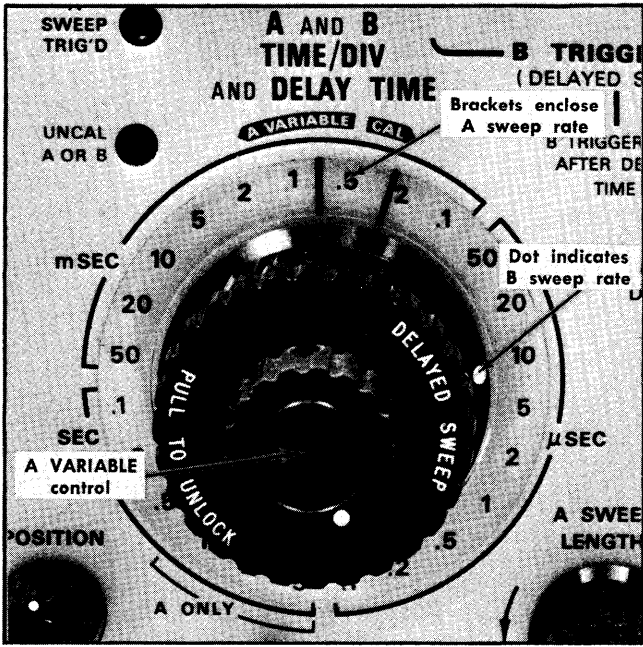

Fig. 2-9. A AND B TIME/DIV switch.

Sweep Magnification

The sweep magnifier expands the sweep ten times. The center division of the unmagnified display is the portion visible on the screen in magnified form (see Fig. 2-11). Equivalent length of the magnified sweep is about 100 divisions; any 10 division portion may be viewed by adjusting the horizontal POSITION control to bring the desired portion onto the viewing area. The FINE position control is particularly useful when the magnifier is on, as it provides positioning in small increments for more precise control.

To use the magnified sweep, first move the portion of the display which is to be expanded to the center of the graticule. Then set the MAG switch to $\times 10$. The FINE position control can be adjusted to position the magnified display

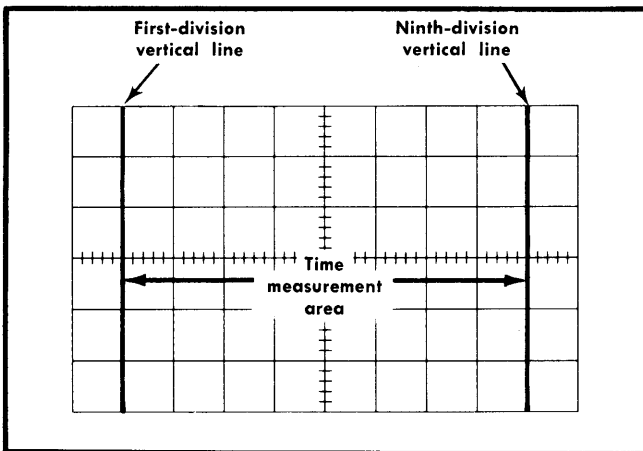

Fig. 2-10. Area of graticule used for accurate time measurements.

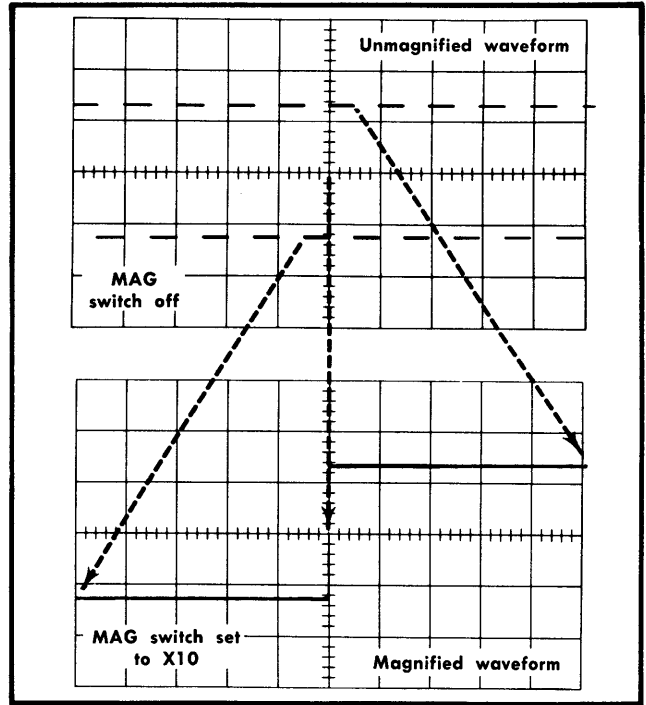

Fig. 2-11. Operation of sweep magnifier.

as desired. The light located below the MAG switch is on whenever the magnifier is on.

When the MAG switch is set to $\times 10$, the sweep rate is determined by dividing the TIME/DIV switch setting by 10. For example, if the TIME/DIV switch is set to $.5 \mu s$, the magnified sweep rate is $0.05 \mu s$ /division. The magnified sweep rate must be used for all time measurements when the MAG switch is set to $\times 10$. The magnified sweep rate is calibrated when the UNCAL A OR B light is off.

Delayed Sweep (B)

The delayed sweep (B sweep) is operable in the A INTEN DURING B and DELAYED SWEEP (B) positions of the HORIZ DISPLAY switch. The A sweep rate along with the DELAY-TIME MULTIPLIER dial setting determines the time that the B sweep is delayed. Sweep rate of the delayed portion is determined by the B TIME/DIV (DELAYED SWEEP) switch setting.

In the A INTEN DURING B position, the display will appear similar to Fig. 2-12A. The amount of delay time between the start of A sweep and the intensified portion is determined by the setting of the A TIME/DIV switch and the DELAY-TIME MULTIPLIER dial.

For example, the delay indicated by the DELAY-TIME MULTIPLIER dial setting shown in Fig. 2-13 is 3.55; this corresponds to 3.55 CRT divisions of A sweep. This reading multiplied by the setting of the A TIME/DIV switch gives the calibrated delay time before the start of the B sweep (see B Sweep Mode which follows). The intensified portion of the display is produced by the B sweep. The length of

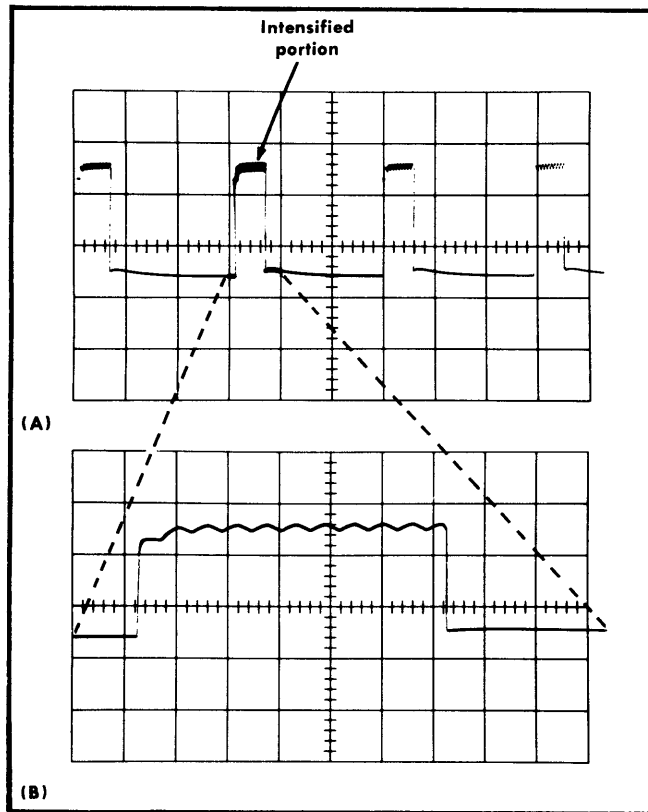

Fig. 2-12. (A) A INTEN DURING B display (DELAY-TIME MULTIPLIER, 2.95; A TIME/DIV, .5 ms; B TIME/DIV, 50 μ s), (B) DELAYED SWEEP (B) display.

this portion is about 10 times the setting of the B TIME/DIV switch.

When the HORIZ DISPLAY switch is set to DELAYED SWEEP (B), only the intensified portion as viewed in the A INTEN DURING B position is displayed on the screen at the sweep rate indicated by the B TIME/DIV switch (see Fig. 2-12B).

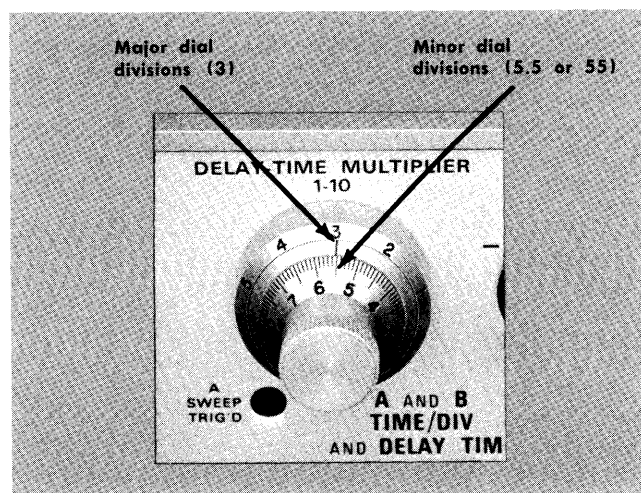

Fig. 2-13. DELAY-TIME MULTIPLIER dial. Reading shown: 3.55.

B SWEEP MODE. The B SWEEP MODE switch provides two modes of delayed sweep operation. Fig. 2-14 illustrates the difference between these two modes. In the B STARTS AFTER DELAY TIME position, the B sweep is presented immediately after the delay time (see Fig. 2-14A). The B sweep is triggered at a selected point on A sweep to provide the delay time (B sweep essentially free running). Since the delay time is the same for each sweep, the display appears stable. In the TRIGGERABLE AFTER DELAY TIME position, the B sweep operates only when it is triggered (by Trigger Circuits) after the selected delay time (see Fig. 2-14B). The B Triggering controls operate as described in this section.

Delayed Sweep Operation. To obtain a delayed sweep display use the following procedure.

1. Obtain a stable display with the HORIZ DISPLAY switch set to A.
2. Set the HORIZ DISPLAY switch to A INTEN DURING B.
3. Set the B SWEEP MODE switch to the desired setting. If TRIGGERABLE AFTER DELAY TIME is selected, correct B Triggering is also necessary.
4. Set the delay time with the A TIME/DIV switch and the DELAY-TIME MULTIPLIER dial.
5. Pull the DELAYED SWEEP (B TIME/DIV) knob out and set to the desired sweep rate.
6. If the TRIGGERABLE AFTER DELAY TIME position is used, check the display for an intensified portion. Absence of the intensified zone indicates that B sweep is not correctly triggered.
7. Set the HORIZ DISPLAY switch to DELAYED SWEEP (B). The intensified zone shown in the A INTEN DURING B position is now displayed at the sweep rate selected by the B TIME/DIV switch.

Several examples using the delayed sweep feature are given under Basic Applications in this section.

A Sweep Length. The A SWEEP LENGTH control is most useful when used with delayed sweep. As the control is rotated counterclockwise from the FULL position, the length of the A sweep decreases (sweep rate remains constant) until it is about four divisions long in the counterclockwise position (not in B ENDS A detent). The B ENDS A position produces a display which ends immediately following B sweep if the B sweep ends before the normal end of A sweep. The A SWEEP LENGTH control is used to increase the repetition rate of delayed sweep displays.

To use the A SWEEP LENGTH control, set the HORIZ DISPLAY switch to A INTEN DURING B and set the delay time and delayed sweep rate in the normal manner. Turn the A SWEEP LENGTH control counterclockwise until the sweep ends immediately following the intensified portion on the display. Now set the HORIZ DISPLAY switch to DELAYED SWEEP (B). This method provides the maximum repetition rate for a given delayed sweep display. In the B ENDS A position, the maximum delayed sweep repetition rate is maintained automatically.

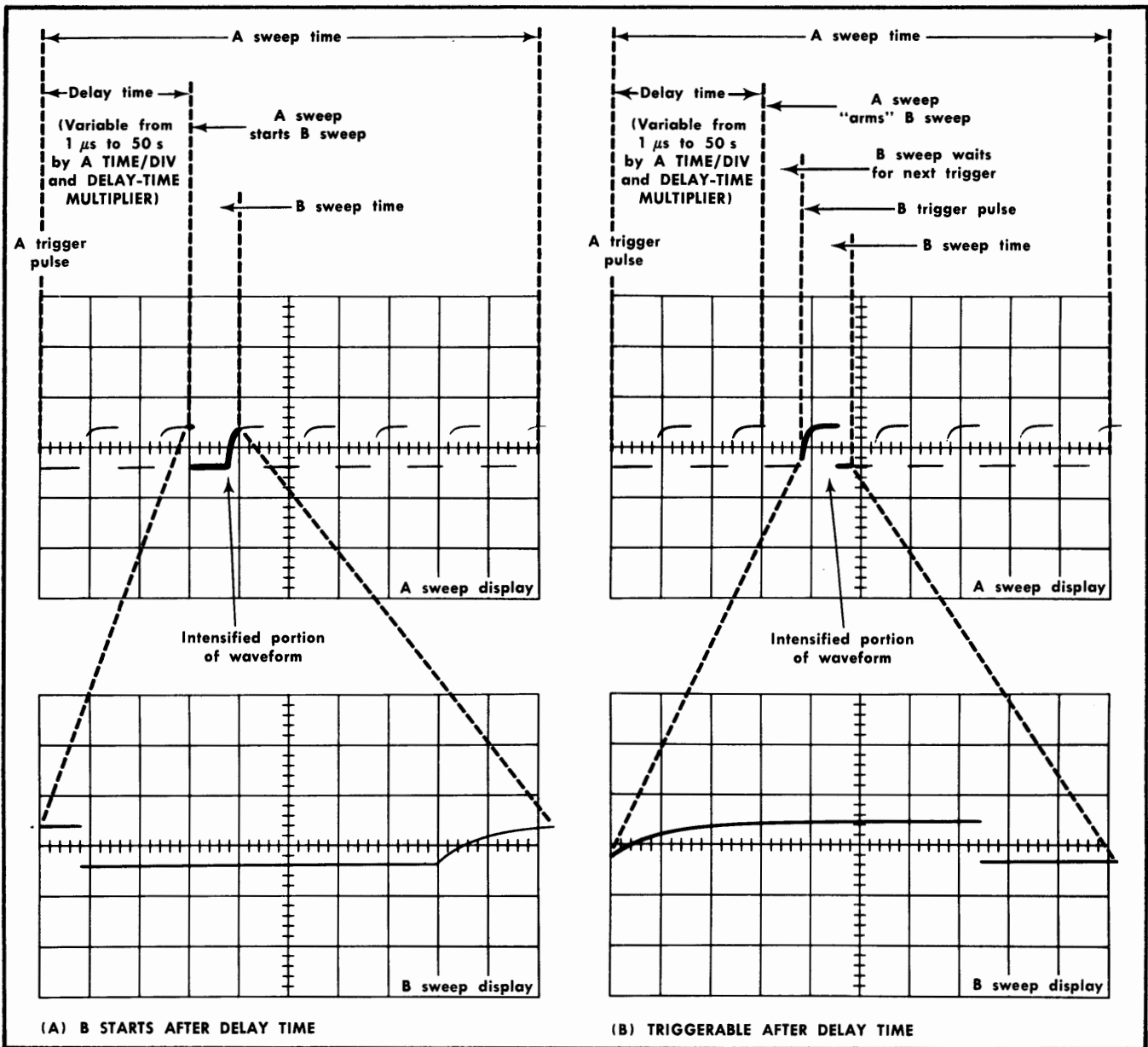

Fig. 2-14. Comparison of the delayed-sweep modes. (A) B STARTS AFTER DELAY TIME, (B) TRIGGERABLE AFTER DELAY TIME. In each display the B sweep is delayed a selected amount of time by A sweep.

NOTE

Jitter can be introduced into the display and incorrect displays produced through the wrong usage of the A SWEEP LENGTH control. When using this control first obtain the best possible display in the FULL position. Then, set the control for the desired A sweep length. If jitter is evident in the display, readjust the Triggering controls or change the A SWEEP LENGTH control to a position that does not cause jitter.

External Horizontal Deflection

In some applications, it is desirable to display one signal versus another (X-Y) rather than against time (internal sweep).

The EXT HORIZ position of the HORIZ DISPLAY switch provides a means for applying an external signal to the horizontal amplifier for this type of display.

Two modes of external horizontal operation are provided. When the TRIGGER switch is set to CH 1 ONLY, the B SOURCE switch to INT and the B COUPLING switch to DC, the horizontal deflection is provided by a signal applied to the Channel 1 INPUT connector. The CH 1 VOLTS/DIV switch setting indicates the calibrated horizontal deflection factor (Channel 1 VARIABLE control in-operative). Center the horizontal POSITION control and use the Channel 1 POSITION control for horizontal positioning.

In the EXT and EXT ÷ 10 positions of the B SOURCE switch, external horizontal deflection is provided by a signal

Operating Instructions—Type 453/R453

applied to the EXT HORIZ input connector (B EXT TRIG INPUT). The signal coupling provided by the B COUPLING switch can be used to select or reject components of the external horizontal signal (all components of external horizontal signal accepted in DC position). Using this mode of operation, the horizontal deflection factor is uncalibrated. External horizontal deflection factor is about 270 millivolts/division in the EXT position of the B SOURCE switch and about 2.7 volts/division in the EXT \div 10 position.

A and B Gate

The A and B Gate output connectors (on side panel) provide a rectangular output pulse which is coincident with the sweep time of the respective sweep generator. This rectangular pulse is about +12 volts in amplitude (into high-impedance loads) with pulse duration the same as the respective sweep.

Intensity Modulation

Intensity (Z-axis) modulation can be used to relate a third item of electrical phenomena to the vertical (Y-axis) and the horizontal (X-axis) coordinates without changing the wave shape. The Z-axis modulating signal applied to the CRT circuit changes the intensity of the displayed waveform to provide this display. "Gray scale" intensity modulation can be obtained by applying signals which do not completely blank the display. Large amplitude signals of the correct polarity will completely blank the display; the sharpest display is provided by signals with a fast rise and fall. The voltage amplitude required for visible trace modulation depends upon the setting of the INTENSITY control. At normal intensity level, a five-volt peak-to-peak signal produces a visible change in brightness. When the Z AXIS INPUT is not in use, keep the ground strap in place to prevent changes in trace intensity due to extraneous noise.

Time markers applied to the Z AXIS INPUT connector provide a direct time reference on the display. With uncalibrated horizontal sweep or external horizontal mode operation, the time markers provide a means of reading time directly from the display. However, if the markers are not time-related to the displayed waveform, a single-sweep display should be used (for internal sweep only) to provide a stable display.

Calibrator

The one-kilohertz square-wave Calibrator of the Type 453 provides a convenient signal source for checking basic vertical gain and sweep timing. However, to provide maximum measurement accuracy, the adjustment procedure given in the Calibration section of this manual should be used. The Calibrator output signal is also very useful for adjusting probe compensation as described in the probe instruction manual. In addition, the calibrator can be used as a convenient signal source for application to external equipment.

Voltage. The Calibrator provides accurate peak-to-peak square-wave voltages of 0.1 and 1 volt into a high impedance load. Voltage range is selected by the CALIBRATOR switch on the side panel. Output resistance is about 200 ohms in the 1 V position and about 20 ohms in the 0.1 V

position. The actual voltage across an external load resistor can be calculated in the same manner as with any series resistor combination (necessary only if the load resistance is less than about 50 kilohms).

Current. The current loop, located on the side panel, provides a five milliamperere peak-to-peak square-wave current which can be used to check and calibrate current-measuring probe systems. This current signal is obtained by clipping the probe around the current loop. Current is constant through the loop in either position of the CALIBRATOR switch. The arrow above the PROBE LOOP indicates conventional current flow; i.e., from + to —.

Frequency. The Calibrator circuit uses frequency-stable components to maintain accurate frequency and constant duty cycle. Thus the Calibrator can be used for checking the basic sweep timing of the horizontal system.

Wave shape. The square-wave output signal of the Calibrator can be used as a reference wave shape when checking or adjusting the compensation of passive, high-resistance probes. Since the square-wave output from the Calibrator has a flat top, any distortion in the displayed waveform is due to the probe compensation.

BASIC APPLICATIONS

General

The following information describes the procedure and technique for making basic measurements with a Type 453 Oscilloscope. These applications are not described in detail since each application must be adapted to the requirements of the individual measurements. Familiarity with the Type 453 will permit these basic techniques to be applied to a wide variety of uses.

Peak-to-Peak Voltage Measurements—AC

To make a peak-to-peak voltage measurement, use the following procedure:

1. Connect the signal to either INPUT connector.
2. Set the MODE switch to display the channel used.
3. Set the VOLTS/DIV switch to display about five divisions of the waveform.
4. Set the Input Coupling switch to AC.

NOTE

For low-frequency signals below about 16 hertz, use the DC position.

5. Set the A Triggering controls to obtain a stable display. Set the TIME/DIV switch to a position that displays several cycles of the waveform.

6. Turn the vertical POSITION control so the lower portion of the waveform coincides with one of the graticule lines below the center horizontal line, and the top of the waveform is on the viewing area. Move the display with the horizontal POSITION control so one of the upper peaks lies near the center vertical line (see Fig. 2-15).

7. Measure the divisions of vertical deflection from peak to peak. Make sure the VARIABLE VOLTS/DIV control is in the CAL position.

NOTE

This technique may also be used to make measurements between two points on the waveform rather than peak to peak.

8. Multiply the distance measured in step 7 by the VOLTS/DIV switch setting. Also include the attenuation factor of the probe, if any.

Example. Assume a peak-to-peak vertical deflection of 4.6 divisions (see Fig. 2-15) using a 10× attenuator probe and a VOLTS/DIV switch setting of .5.

Using the formula:

$$\text{Volts Peak to Peak} = \text{vertical deflection (divisions)} \times \text{VOLTS/DIV setting} \times \text{probe attenuation factor}$$

Substituting the given values:

$$\text{Volts Peak to Peak} = 4.6 \times 0.5 \text{ V} \times 10$$

The peak-to-peak voltage is 23 volts.

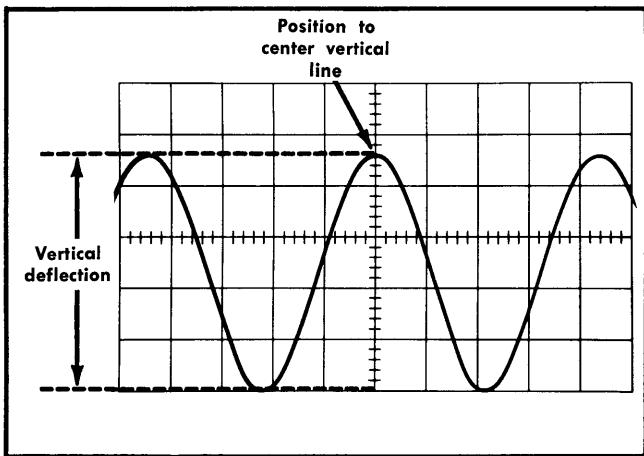

Fig. 2-15. Measuring peak-to-peak voltage of a waveform.

Instantaneous Voltage Measurements—DC

To measure the DC level at a given point on a waveform, use the following procedure:

1. Connect the signal to either INPUT connector.
2. Set the MODE switch to display the channel used.
3. Set the VOLTS/DIV switch to display about five divisions of the waveform.
4. Set the Input Coupling switch to GND.
5. Set the A SWEEP MODE switch to AUTO TRIG.
6. Position the trace to the bottom line of the graticule or other reference line. If the voltage is negative with respect to ground, position the trace to the top line of the graticule.

Do not move the vertical POSITION control after this reference line has been established.

NOTE

To measure a voltage level with respect to a voltage rather than ground, make the following changes in step 6. Set the Input Coupling switch to DC and apply the reference voltage to the INPUT connector. Then position the trace to the reference line.

7. Set the Input Coupling switch to DC. The ground reference line can be checked at any time by switching to the GND position (except when using a DC reference voltage).

8. Set the A Triggering controls to obtain a stable display. Set the TIME/DIV switch to a setting that displays several cycles of the signal.

9. Measure the distance in divisions between the reference line and the point on the waveform at which the DC level is to be measured. For example, in Fig. 2-16 the measurement is made between the reference line and point A.

10. Establish the polarity of the signal. If the waveform is above the reference line, the voltage is positive; below the line, negative (when the INVERT switch is pushed in if using Channel 2).

11. Multiply the distance measured in step 9 by the VOLTS/DIV switch setting. Include the attenuation factor of the probe, if any.

Example. Assume that the vertical distance measured is 4.6 divisions (see Fig. 2-16), the waveform is above the reference line, using a 10× attenuator probe and a VOLTS/DIV setting of 2.

Using the formula:

$$\text{Instantaneous Voltage} = \text{vertical distance (divisions)} \times \text{polarity} \times \text{VOLTS/DIV setting} \times \text{probe attenuation factor}$$

Substituting the given values:

$$\text{Instantaneous Voltage} = 4.6 \times +1 \times 2 \text{ V} \times 10$$

The instantaneous voltage is +92 volts.

Voltage Comparison Measurements

In some applications it may be necessary to establish a set of deflection factors other than those indicated by the VOLTS/DIV switch. This is useful for comparing signals to a reference voltage amplitude. To establish a new set of deflection factors based upon a specific reference amplitude, proceed as follows:

1. Apply the reference signal of known amplitude to either INPUT connector. Set the MODE switch to display the channel used. Using the VOLTS/DIV switch and the VARIABLE control, adjust the display for an exact number of divisions. Do not move the VARIABLE VOLTS/DIV control after obtaining the desired deflection.

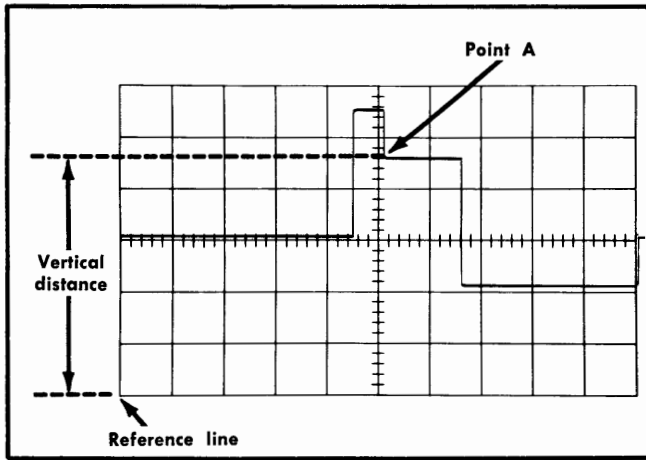

Fig. 2-16. Measuring instantaneous DC voltage with respect to a reference.

2. Divide the amplitude of the reference signal (volts) by the product of the deflection in divisions (established in step 1) and the VOLTS/DIV switch setting. This is the Deflection Conversion Factor.

$$\text{Deflection Conversion Factor} = \frac{\text{reference signal amplitude (volts)}}{\text{deflection (divisions)} \times \text{VOLTS/DIV setting}}$$

3. To establish an Adjusted Deflection Factor at any setting of the VOLTS/DIV switch, multiply the VOLTS/DIV switch setting by the Deflection Conversion Factor established in step 2.

$$\text{Adjusted Deflection Factor} = \text{VOLTS/DIV setting} \times \text{Deflection Conversion Factor}$$

This Adjusted Deflection Factor applies only to the channel used and is correct only if the VARIABLE VOLTS/DIV control is not moved from the position set in step 1.

4. To determine the peak to peak amplitude of a signal compared to a reference, disconnect the reference and apply the signal to the INPUT connector.

5. Set the VOLTS/DIV switch to a setting that will provide sufficient deflection to make the measurement. Do not re-adjust the VARIABLE VOLTS/DIV control.

6. Measure the vertical deflection in divisions and determine the amplitude by the following formula:

$$\text{Signal Amplitude} = \frac{\text{Adjusted Deflection Factor} \times \text{deflection (divisions)}}{1}$$

Example. Assume a reference signal amplitude of 30 volts, a VOLTS/DIV setting of 5 and a deflection of 4 divisions. Substituting these values in the Deflection Conversion Factor formula (step 2):

$$\text{Deflection Conversion Factor} = \frac{30 \text{ V}}{4 \times 5 \text{ V}} = 1.5$$

Then, with a VOLTS/DIV switch setting of 10, the Adjusted Deflection Factor (step 3) is:

$$\text{Adjusted Deflection Factor} = 10 \text{ V} \times 1.5 = 15 \text{ volts/division}$$

To determine the peak-to-peak amplitude of an applied signal which produces a vertical deflection of 5 divisions, use the Signal Amplitude formula (step 6):

$$\text{Signal Amplitude} = 15 \text{ V} \times 5 = 75 \text{ volts}$$

Time-Duration Measurements

To measure time between two points on a waveform, use the following procedure.

1. Connect the signal to either INPUT connector.
2. Set the MODE switch to display the channel used.
3. Set the VOLTS/DIV switch to display about five divisions of the waveform.
4. Set the A Triggering controls to obtain a stable display.
5. Set the TIME/DIV switch to the fastest sweep rate that displays less than eight divisions between the time measurement points (see Fig. 2-17). (See the topic entitled Selecting Sweep Rate in this section concerning non-linearity of first and last divisions of display.)
6. Adjust the vertical POSITION control to move the points between which the time measurement is made to the center horizontal line.
7. Adjust the horizontal POSITION control to center the display within the center eight divisions of the graticule.
8. Measure the horizontal distance between the time measurement points. Be sure the A VARIABLE control is set to CAL.
9. Multiply the distance measured in step 8 by the setting of the TIME/DIV switch. If sweep magnification is used, divide this answer by 10.

Example. Assume that the distance between the time measurement points is 5 divisions (see Fig. 2-17) and the TIME/DIV switch is set to .1 ms with the magnifier off.

Using the formula:

$$\text{Time Duration} = \frac{\text{horizontal distance (divisions)} \times \text{TIME/DIV setting}}{\text{magnification}}$$

Substituting the given values:

$$\text{Time Duration} = \frac{5 \times 0.1 \text{ ms}}{1}$$

The time duration is 0.5 milliseconds.

Frequency Measurements

The time measurement technique can also be used to measure the frequency of a signal. The frequency of a periodically-recurrent signal is the reciprocal of the time duration of one cycle.

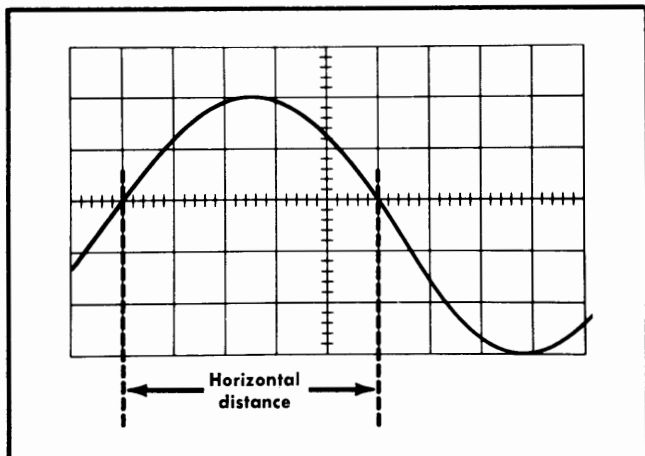

Fig. 2-17. Measuring the time duration between points on a waveform.

1. Measure the time duration of one cycle of the waveform as described in the previous application.
2. Take the reciprocal of the time duration to determine the frequency.

Example. The frequency of the signal shown in Fig. 2-17 which has a time duration of 0.5 milliseconds is:

$$\text{Frequency} = \frac{1}{\text{time duration}} = \frac{1}{0.5 \text{ ms}} = 2 \text{ kHz}$$

Risetime Measurements

Risetime measurements employ basically the same techniques as time-duration measurements. The main difference is the points between which the measurement is made. The following procedure gives the basic method of measuring risetime between the 10% and 90% points of the waveform. Falltime can be measured in the same manner on the trailing edge of the waveform.

1. Connect the signal to either INPUT connector.
2. Set the MODE switch to display the channel used.
3. Set the VOLTS/DIV switch and the VARIABLE control to produce a display an exact number of divisions in amplitude.
4. Center the display about the center horizontal line.
5. Set the A Triggering controls to obtain a stable display.
6. Set the TIME/DIV switch to the fastest sweep rate that displays less than eight divisions between the 10% and 90% points on the waveform.
7. Determine the 10% and 90% points on the rising portion of the waveform. The figures given in Table 2-2 are for the points 10% up from the start of the rising portion and 10% down from the top of the rising portion (90% point).

8. Adjust the horizontal POSITION control to move the 10% point of the waveform to the first graticule line. For

Vertical display (divisions)	10% and 90% points	Divisions vertically between 10% & 90% points
4	0.4 and 3.6 divisions	3.2
5	0.5 and 3.5 divisions	4.0
6	0.6 and 3.4 divisions	4.8

example, with a five-division display as shown in Fig. 2-18, the 10% point is 0.5 division up from the start of the rising portion.

9. Measure the horizontal distance between the 10% and 90% points. Be sure the A VARIABLE control is set to CAL.

10. Multiply the distance measured in step 8 by the setting of the TIME/DIV switch. If sweep magnification is used, divide this answer by 10.

Example. Assume that the horizontal distance between the 10% and 90% points is four divisions (see Fig. 2-18) and the TIME/DIV switch is set to 1 μs with the MAG switch set to ×10.

Applying the time duration formula to risetime:

$$\text{Risetime (Time Duration)} = \frac{\text{horizontal distance (divisions)} \times \text{TIME/DIV setting}}{\text{magnification}}$$

Substituting the given values:

$$\text{Risetime} = \frac{4 \times 1 \mu\text{s}}{10}$$

The risetime is 0.4 microsecond.

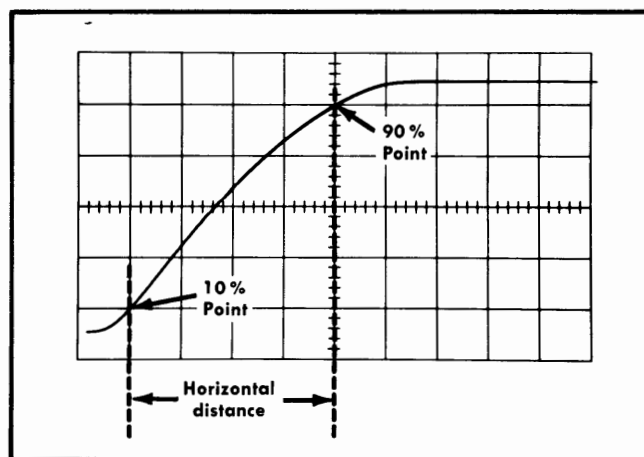

Fig. 2-18. Measuring risetime.

Time-Difference Measurements

The calibrated sweep rate and dual-trace features of the Type 453 allow measurement of time difference between two separate events. To measure time difference, use the following procedure.

Operating Instructions—Type 453/R453

1. Set the Input Coupling switches to the desired coupling positions.

2. Set the MODE switch to either CHOP or ALT. In general, CHOP is more suitable for low-frequency signals and the ALT position is more suitable for high-frequency signals. More information on determining the mode is given under Dual-Trace Operation in this section.

3. Set the TRIGGER switch to CH 1 ONLY.

4. Connect the reference signal to Channel 1 INPUT and the comparison signal to Channel 2 INPUT. The reference signal should precede the comparison signal in time. Use coaxial cables or probes which have equal time delay to connect the signals to the INPUT connectors.

5. If the signals are of opposite polarity, pull out the INVERT switch to invert the Channel 2 display (signal may be of opposite polarity due to 180° time difference; if so, take into account in final calculation).

6. Set the VOLTS/DIV switches to produce four- or five-division displays.

7. Set the A LEVEL control for a stable display.

8. If possible, set the TIME/DIV switch for a sweep rate which shows three or more divisions between the two waveforms.

9. Adjust the vertical POSITION controls to center each waveform (or the points on the display between which the measurement is made) in relation to the center horizontal line.

10. Adjust the horizontal POSITION control so the Channel 1 (reference) waveform crosses the center horizontal line at a vertical graticule line.

11. Measure the horizontal difference between the Channel 1 waveform and the Channel 2 waveform (see Fig. 2-19).

12. Multiply the measured difference by the setting of the TIME/DIV switch. If sweep magnification is used, divide this answer by 10.

Example. Assume that the TIME/DIV switch is set to 50 μ s, the MAG switch to $\times 10$ and the horizontal difference between waveforms is 4.5 divisions (see Fig. 2-19).

Using the formula:

$$\text{Time Delay} = \frac{\text{TIME/DIV setting} \times \text{horizontal difference (divisions)}}{\text{magnification}}$$

Substituting the given values:

$$\text{Time Delay} = \frac{50 \mu\text{s} \times 4.5}{10}$$

The time delay is 22.5 microseconds.

Delayed Sweep Time Measurements

The delayed sweep mode can be used to make accurate time measurements. The following measurement determines the time difference between two pulses displayed on the same trace. This application may also be used to measure

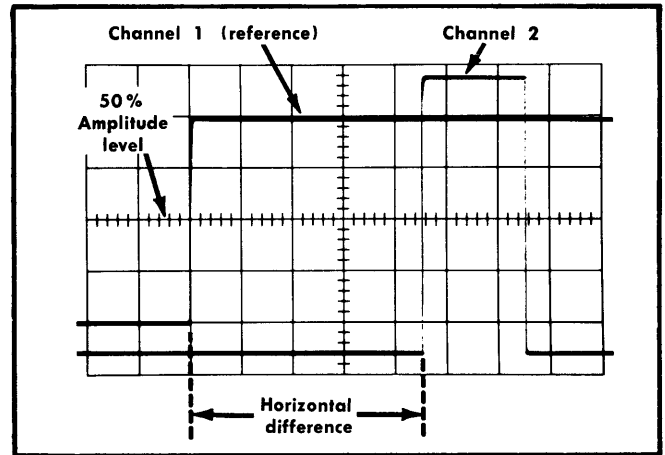

Fig. 2-19. Measuring time difference between two pulses.

time difference from two different sources (dual-trace) or to measure time duration of a single pulse. See Section 1 for measurement accuracy.

1. Connect the signal to either INPUT connector. Set the MODE switch to display the channel used.

2. Set the VOLTS/DIV switch to produce a display about four divisions in amplitude.

3. Adjust the A Triggering controls for a stable display.

4. If possible, set the A TIME/DIV switch to a sweep rate which displays about eight divisions between the pulses.

5. Set the HORIZ DISPLAY switch to A INTEN DURING B and the B SWEEP MODE switch to B STARTS AFTER DELAY TIME.

6. Set the B TIME/DIV switch to a setting 1/100 of the A TIME/DIV sweep rate. This produces an intensified portion about 0.1 division in length.

NOTE

Do not change the A LEVEL control setting or the horizontal POSITION control setting in the following steps as the measurement accuracy will be affected.

7. Turn the DELAY-TIME MULTIPLIER dial to move the intensified portion to the first pulse.

8. Set the HORIZ DISPLAY switch to DELAYED SWEEP (B).

9. Adjust the DELAY-TIME MULTIPLIER dial to move the pulse (or the rising portion) to the center vertical line. Note the setting of the DELAY-TIME MULTIPLIER dial.

10. Turn the DELAY-TIME MULTIPLIER dial clockwise until the second pulse is positioned to this same point (if several pulses are displayed, return to the A INTEN DURING B position to locate the correct pulse). Again note the dial setting.

11. Subtract the first dial setting from the second and multiply by the delay time shown by the A TIME/DIV switch. This is the time interval between the pulses.

Example. Assume the first dial setting is 1.31 and the second dial setting is 8.81 with the TIME/DIV switch set to 0.2 microsecond (see Fig. 2-20).

Using the formula:

$$\text{Time Difference (delayed sweep)} =$$

$$[\text{second dial setting} - \text{first dial setting}] \times (\text{A TIME/DIV setting}) \times \text{delay time}$$

Substituting the given values:

$$\text{Time Difference} = [8.81 - 1.31] \times 0.2 \mu\text{s}$$

The time difference is 1.5 microseconds.

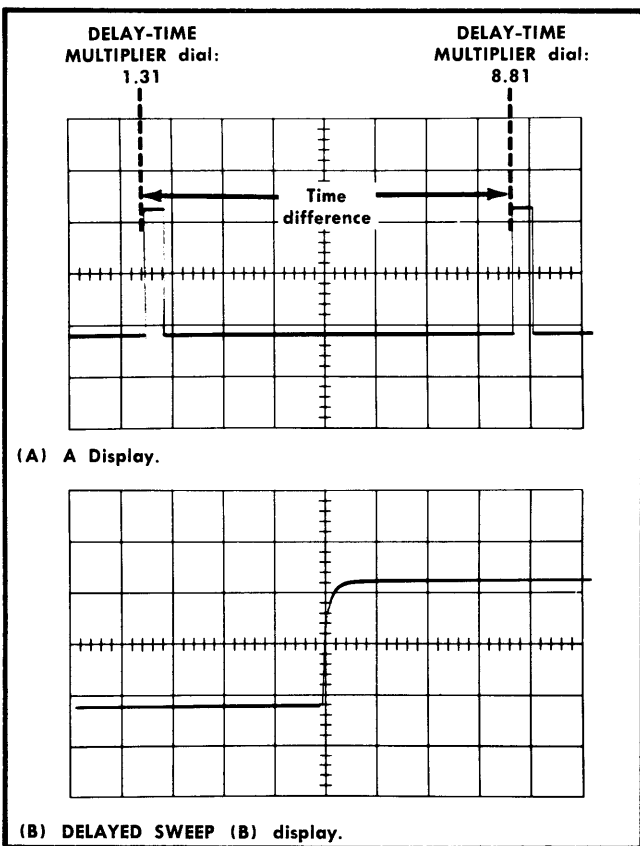

Fig. 2-20. Measuring time difference using delayed sweep.

Delayed Sweep Magnification

The delayed sweep feature of the Type 453 can be used to provide higher apparent magnification than is provided by the MAG switch. The sweep rate of the DELAYED SWEEP (B sweep) is not actually increased; the apparent magnification is the result of delaying the B sweep an amount of time selected by the A TIME/DIV switch and the DELAY-TIME MULTIPLIER dial before the display is presented at the sweep rate selected by the B TIME/DIV switch. The following methods uses the B STARTS AFTER DELAY TIME position to allow the delayed portion to be positioned with the DELAY-TIME MULTIPLIER dial. If there is too much jitter in the delay-

ed display, use the Triggered Delayed Sweep Magnification procedure.

1. Connect the signal to either INPUT connector. Set the MODE switch to display the channel used.
2. Set the VOLTS/DIV switch to produce a display about 4 divisions in amplitude.
3. Adjust the A Triggering controls for a stable display.
4. Set the A TIME/DIV switch to a sweep rate which displays the complete waveform.
5. Set the HORIZ DISPLAY switch to A INTEN DURING B and the B SWEEP MODE switch to B STARTS AFTER DELAY TIME.
6. Position the start of the intensified portion with the DELAY-TIME MULTIPLIER dial to the part of the display to be magnified.
7. Set the B TIME/DIV switch to a setting which intensifies the full portion to be magnified. The start of the intensified trace will remain as positioned above.
8. Set the HORIZ DISPLAY switch to DELAYED SWEEP (B).
9. Time measurements can be made from the display in the conventional manner. Sweep rate is determined by the setting of the B TIME/DIV switch.
10. The apparent sweep magnification can be calculated by dividing the A TIME/DIV switch setting by the B TIME/DIV switch setting.

Example: The apparent magnification of the display shown in Fig. 2-21 with an A TIME/DIV switch setting of .1 ms and a B TIME/DIV switch setting of 1 μs is:

$$\text{Apparent Magnification (delayed sweep)} = \frac{\text{A TIME/DIV setting}}{\text{B TIME/DIV setting}}$$

Substituting the given values:

$$\text{Apparent Magnification} = \frac{1 \times 10^{-4}}{1 \times 10^{-6}}$$

The apparent magnification is 100 times.

Triggered Delayed Sweep Magnification. The delayed sweep magnification method just described may produce too much jitter at high apparent magnification ranges. The TRIGGERABLE AFTER DELAY TIME position of the B SWEEP MODE switch provides a more stable display since the delayed display is triggered at the same point each time.

1. Set up the display as given in steps 1 through 7 described above.
2. Set the B SWEEP MODE switch to TRIGGERABLE AFTER DELAY TIME.
3. Adjust the B LEVEL control so the intensified portion on the trace is stable. (If an intensified portion cannot be obtained, see step 4.)
4. Inability to intensify the desired portion indicates that the B Triggering controls are incorrectly set or the signal does not meet the triggering requirements. If the condition cannot be remedied with the B Triggering controls or by

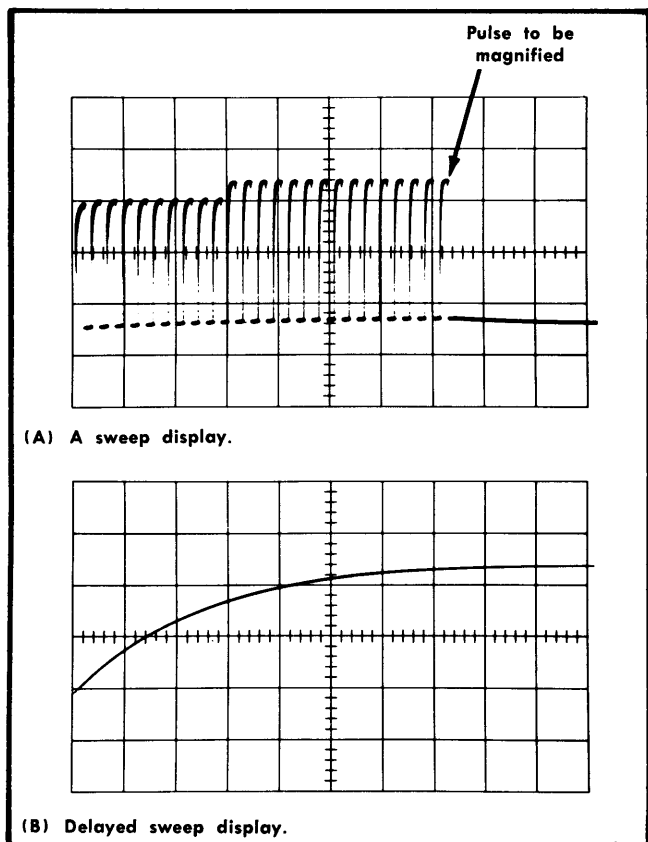

Fig. 2-21. Using delayed sweep for sweep magnification.

increasing the display amplitude (lower VOLTS/DIV setting), externally trigger B sweep.

5. When the correct portion is intensified, set the HORIZ DISPLAY switch to DELAYED SWEEP (B). Slight readjustment of the B LEVEL control may be necessary for a stable display.

6. Measurement and magnification are as described above.

Displaying Complex Signals Using Delayed Sweep

Complex signals often consist of a number of individual events of differing amplitudes. Since the trigger circuits are sensitive to changes in signal amplitude, a stable display can normally be obtained only when the sweep is triggered by the event(s) having the greatest amplitude. However, this may not produce the desired display of a lower amplitude event which follows the triggering event. The delayed sweep feature provides a means of delaying the start of the B sweep by a selected amount following the event which triggers the A Sweep Generator. Then, the part of the waveform which contains the information of interest can be displayed.

Use the following procedure:

1. Connect the signal to either INPUT connector. Set the MODE switch to display the channel used.

2. Set the VOLTS/DIV switch to produce a display about four divisions in amplitude.

3. Adjust the A Triggering controls for a stable display.

4. Set the A TIME/DIV switch to a sweep rate which displays the complete waveform.

5. Set the HORIZ DISPLAY switch to A INTEN DURING B and the B SWEEP MODE switch to B STARTS AFTER DELAY TIME.

6. Position the start of the intensified portion with the DELAY-TIME MULTIPLIER dial to the part of the display to be magnified.

7. Set the B TIME/DIV switch to a setting which intensifies the full portion to be magnified. The start of the intensified trace will remain as positioned above.

8. Set the HORIZ DISPLAY switch to DELAYED SWEEP (B).

9. Time measurements can be made from the display in the conventional manner. Sweep rate is determined by the setting of the B TIME/DIV switch.

Example. Fig. 2-22 shows a complex waveform as displayed on the CRT. The circled portion of the waveform cannot be viewed in any greater detail because the sweep is triggered by the larger amplitude pulses at the start of the display and a faster sweep rate moves this area of the waveform off the viewing area. The second waveform shows the area of interest magnified 10 times using Delayed Sweep. The DELAY-TIME MULTIPLIER dial has been adjusted so the delayed sweep starts just before the area of interest.

Pulse Jitter Measurements

In some applications it is necessary to measure the amount of jitter on the leading edge of a pulse, or jitter between pulses.

Use the following procedure:

1. Connect the signal to either INPUT connector. Set the MODE switch to display the channel used.

2. Set the VOLTS/DIV switch to display about four divisions of the waveform.

3. Set the A TIME/DIV switch to a sweep rate which displays the complete waveform.

4. Set the A Triggering controls to obtain as stable a display as possible.

5. Set the HORIZ DISPLAY switch to A INTEN DURING B and the B SWEEP MODE switch to B STARTS AFTER DELAY TIME.

6. Position the start of the intensified portion with the DELAY-TIME MULTIPLIER dial so the pulse to be measured is intensified.

7. Set the B TIME/DIV switch to a setting which intensifies the full portion of the pulse that shows jitter.

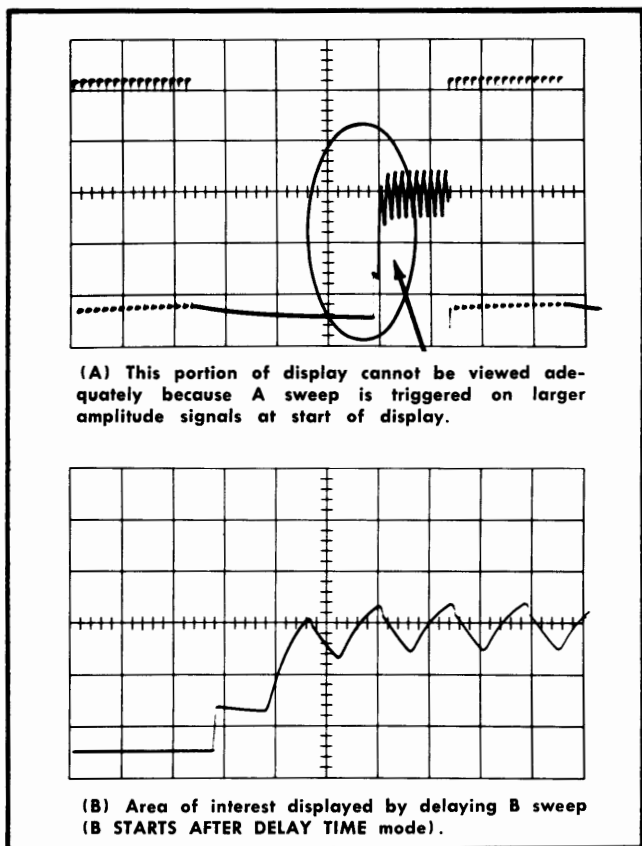

Fig. 2-22. Displaying a complex signal using delayed sweep.

8. Set the HORIZ DISPLAY switch to DELAYED SWEEP (B).

9. Pulse jitter is shown by horizontal movement of the pulse (take into account inherent jitter of Delayed Sweep). Measure the amount of horizontal movement. Be sure both VARIABLE controls are set to CAL.

10. Multiply the distance measured in step 9 by the B TIME/DIV switch setting to obtain pulse jitter in time.

Example. Assume that the horizontal movement is 0.5 divisions (see Fig. 2-23), and the B TIME/DIV switch setting is $.5 \mu\text{s}$.

Using the formula:

$$\text{Pulse Jitter} = \frac{\text{horizontal jitter (divisions)}}{\text{B TIME/DIV setting}} \times \text{B TIME/DIV setting}$$

Substituting the given value:

$$\text{Pulse Jitter} = 0.5 \times 0.5 \mu\text{s}$$

The pulse jitter is 0.25 microseconds.

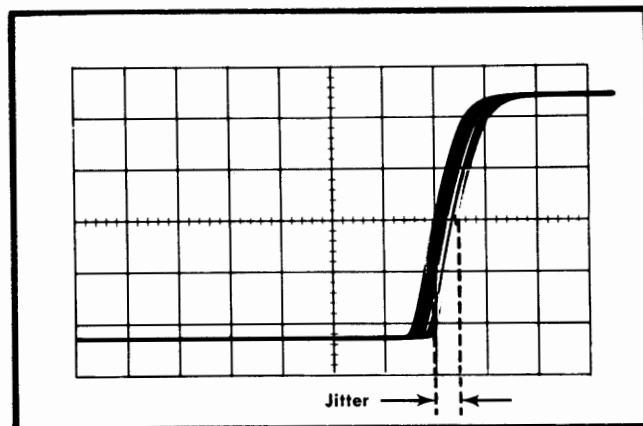

Fig. 2-23. Measuring pulse jitter.

Delayed Trigger Generator

The B GATE output signal can be used to trigger an external device at a selected delay time after the start of A Sweep. The delay time of the B GATE output signal can be selected by the setting of the DELAY-TIME MULTIPLIER dial and A TIME/DIV switch.

A Sweep Triggered Internally. When A sweep is triggered internally to produce a normal display, the delayed trigger may be obtained as follows.

1. Obtain a triggered display in the normal manner.
2. Set the HORIZ DISPLAY switch to A INTEN DURING B.
3. Select the amount of delay from the start of A Sweep with the DELAY-TIME MULTIPLIER dial. Delay time can be calculated in the normal manner.
4. Set the B SWEEP MODE switch to B STARTS AFTER DELAY TIME.
5. Connect the B GATE signal to the external equipment.
6. The duration of the B GATE signal is determined by the setting of the B TIME/DIV switch.
7. The external equipment will be triggered at the start of the intensified portion if it responds to positive-going triggers, or at the end of the intensified portion if it responds to negative-going triggers.

A Sweep Triggered Externally. This mode of operation can be used to produce a delayed trigger with or without a corresponding display. Connect the external trigger signal to the A EXT TRIG INPUT connector and set the A SOURCE switch to EXT. Follow the operation given above to obtain the delayed trigger.

Normal Trigger Generator

Ordinarily, the signal to be displayed also provides the trigger signal for the oscilloscope. In some instances, it may be desirable to reverse this situation and have the oscilloscope trigger the signal source. This can be done by connecting the A GATE signal to the input of the signal source. Set the A LEVEL control fully clockwise, A SWEEP

Operating Instructions—Type 453/R453

MODE switch to AUTO TRIG and adjust the A TIME/DIV switch for the desired display. Since the signal source is triggered by a signal that has a fixed time relationship to the sweep, the output of the signal source can be displayed on the CRT as though the Type 453 were triggered in the normal manner (this method does not allow selection of trigger level or coupling).

Multi-Trace Phase Difference Measurements

Phase comparison between two signals of the same frequency can be made using the dual-trace feature of the Type 453. This method of phase difference measurement can be used up to the frequency limit of the vertical system. To make the comparison, use the following procedure.

1. Set the Input Coupling switches to the same position, depending on the type of coupling desired.

2. Set the MODE switch to either CHOP or ALT. In general, CHOP is more suitable for low-frequency signals and the ALT position is more suitable for high-frequency signals. More information on determining the mode is given under Dual-Trace Operation in this section.

3. Set the TRIGGER switch to CH 1 ONLY.

4. Connect the reference signal to the Channel 1 INPUT connector and the comparison signal to the Channel 2 INPUT connector. The reference signal should precede the comparison signal in time. Use coaxial cables or probes which have equal time delay to connect the signals to the INPUT connectors.

5. If the signals are of opposite polarity, pull the INVERT switch out to invert the Channel 2 display. (Signals may be of opposite polarity due to 180° phase difference; if so, take this into account in the final calculation.)

6. Set the CH 1 and CH 2 VOLTS/DIV switches and the VARIABLE VOLTS/DIV controls so the displays are equal and about five divisions in amplitude.

7. Set the triggering controls to obtain a stable display.

8. Set the TIME/DIV switch to a sweep rate which displays about one cycle of the waveform.

9. Move the waveforms to the center of the graticule with the vertical POSITION controls.

10. Turn the A VARIABLE control until one cycle of the reference signal (Channel 1) occupies exactly eight divisions horizontally (see Fig. 2-24). Each division of the graticule represents 45° of the cycle ($360^\circ \div 8 \text{ divisions} = 45^\circ / \text{division}$). The sweep rate can be stated in terms of degrees as 45°/division.

11. Measure the horizontal difference between corresponding points on the waveforms.

12. Multiply the measured distance (in divisions) by 45°/division (sweep rate) to obtain the exact amount of phase difference.

Example. Assume a horizontal difference of 0.6 divisions with a sweep rate of 45°/division as shown in Fig. 2-24.

Using the formula:

$$\text{Phase Difference} = \frac{\text{horizontal difference (divisions)}}{\text{horizontal difference (divisions)}} \times \text{sweep rate (degrees/div)}$$

Substituting the given values:

$$\text{Phase Difference} = 0.6 \times 45^\circ$$

The phase difference is 27°.

High Resolution Phase Measurements

More accurate dual-trace phase measurements can be made by increasing the sweep rate (without changing the A VARIABLE control setting). One of the easiest ways to increase the sweep rate is with the MAG switch. Delayed sweep magnification may also be used. The magnified sweep rate is determined by dividing the sweep rate obtained previously by the amount of sweep magnification.

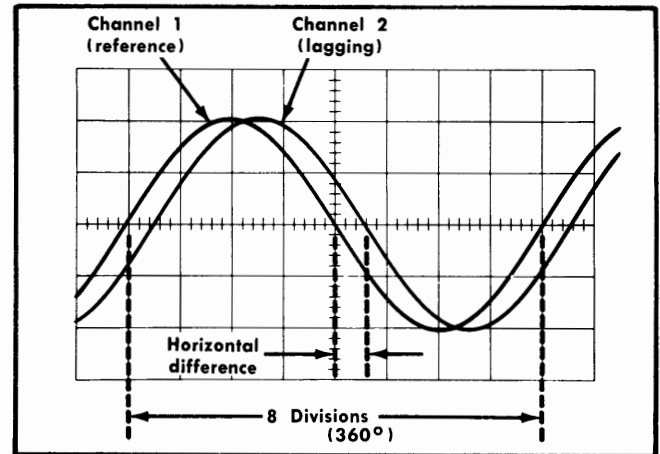

Fig. 2-24. Measuring phase difference.

Example. If the sweep rate were increased 10 times with the magnifier, the magnified sweep rate would be $45^\circ / \text{division} \div 10 = 4.5^\circ / \text{division}$. Fig. 2-25 shows the same signals as used in Fig. 2-24 but with the MAG switch set to $\times 10$. With a horizontal difference of six divisions, the phase difference is:

$$\text{Phase Difference} = \frac{\text{horizontal difference (divisions)}}{\text{horizontal difference (divisions)}} \times \text{magnified sweep rate (degrees/div)}$$

Substituting the given values:

$$\text{Phase Difference} = 6 \times 4.5^\circ.$$

The phase difference is 27°.

X-Y Phase Measurements

The X-Y phase measurement method can be used to measure the phase difference between the two signals of the same frequency. This method provides an alternate method of measurement for signal frequencies up to about 100 kilohertz. However, above this frequency the inherent phase

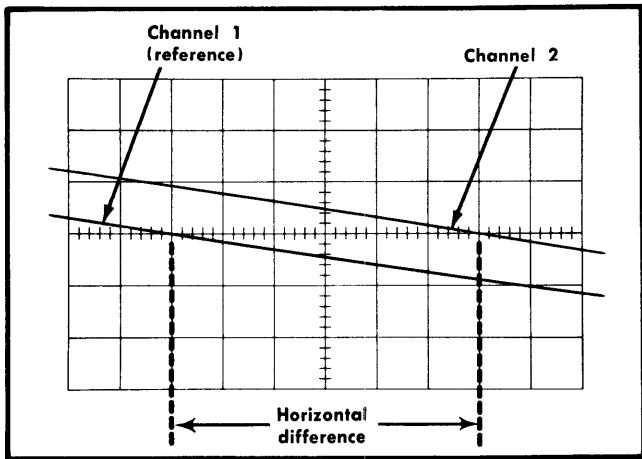

Fig. 2-25. High resolution phase-difference measurement with increased sweep rate.

difference between the vertical and horizontal systems makes accurate phase measurement difficult. In this mode, one of the sine-wave signals provides horizontal deflection (X) while the other signal provides the vertical deflection (Y). The phase angle between the two signals can be determined from the lissajous pattern as follows.

1. Connect one of the sine-wave signals to both the Channel 1 INPUT and the Channel 2 INPUT connectors. (Note: steps 1 through 5 measure inherent phase difference between the X and Y amplifiers to provide a more accurate X-Y phase measurement; not necessary below about 1 kHz).

2. Set the HORIZ DISPLAY switch to EXT HORIZ. Set the TRIGGER switch to CH 1 ONLY and the B SOURCE switch to INT.

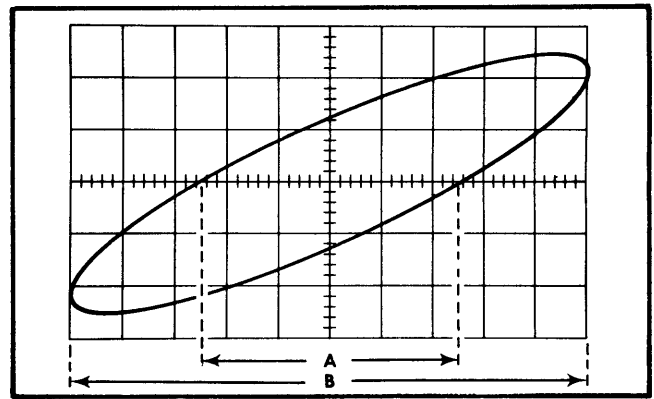

Fig. 2-26. Phase-difference measurement from an X-Y display.

3. Position the display to the center of the screen and adjust the VOLTS/DIV switches to produce a display less than 6 divisions vertically (Y) and less than 10 divisions horizontally (X). The CH 1 VOLTS/DIV switch controls the horizontal deflection (X) and the CH 2 VOLTS/DIV switch controls the vertical deflection (Y).

4. Center the display in relation to the vertical graticule line. Measure the distances A and B as shown in Fig. 2-26. Distance A is the horizontal measurement between the two points where the trace crosses the center horizontal line. Distance B is the maximum horizontal width of the display.

5. Divide A by B to obtain the sine of the phase angle (ϕ) between the two signals. The angle can then be obtained from a trigonometric table. This is the inherent phase shift of the instrument.

6. Connect the Y signal to Channel 2 INPUT connector. Repeat steps 2 through 5 to measure phase angle. If the dis-

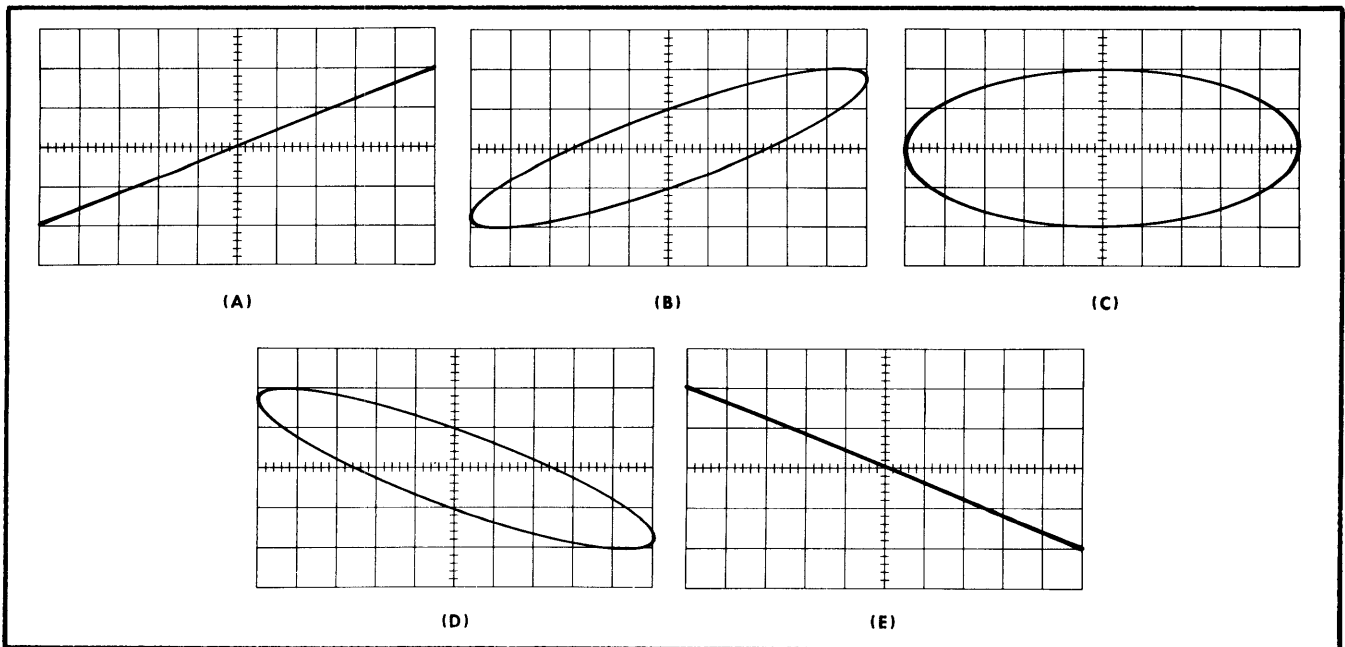

Fig. 2-27. Phase of lissajous display. (A) 0° or 360° , (B) 30° or 330° , (C) 90° or 270° , (D) 150° or 210° and (E) 180° .

Operating Instructions—Type 453/R453

play appears as a diagonal straight line, the two signals are either in phase (tilted upper right to lower left) or 180° out of phase (tilted upper left to lower right). If the display is a circle, the signals are 90° out of phase. Fig. 2-27 shows the lissajous displays produced between 0° and 360° . Notice that above 180° phase shift, the resultant display is the same as at some lower angle.

7. Subtract the inherent phase shift from the phase angle ϕ to obtain the actual phase difference.

Example. Assume an inherent phase difference of 2° with a display as shown in Fig. 2-26 where A is 5 divisions and B is 10 divisions.

Using the formula:

$$\text{Sine } \phi = \frac{A}{B}$$

Substituting the given values:

$$\text{Sine } \phi = \frac{5}{10} = 0.5$$

From the trigonometric tables:

$$\phi = 30^\circ$$

Common-Mode Rejection

The ADD feature of the Type 453 can be used to display signals which contain undesirable components. These undesirable components can be eliminated through common-mode rejection. The precautions given under Algebraic Addition should be observed.

1. Connect the signal containing both the desired and undesired information to the Channel 1 INPUT connector.

2. Connect a signal similar to the unwanted portion of the Channel 1 signal to the Channel 2 INPUT connector. For example, in Fig. 2-28 a line-frequency signal is connected to Channel 2 to cancel out the line-frequency component of the Channel 1 signal.

3. Set both Input Coupling switches to DC (AC if DC component of input signal is too large).

4. Set the MODE switch to ALT. Set the VOLTS/DIV switches so the signals are about equal in amplitude.

5. Set the TRIGGER switch to NORM.

6. Set the MODE switch to ADD. Pull the INVERT switch so the common-mode signals are of opposite polarity.

7. Adjust the CH 2 VOLTS/DIV switch and VARIABLE control for maximum cancellation of the common-mode signal.

8. The signal which remains should be only the desired portion of the Channel 1 signal. The undesired signal is cancelled out.

Example. An example of this mode of operation is shown in Fig. 2-28. The signal applied to Channel 1 contains unwanted line-frequency components (Fig. 2-28A). A corresponding line-frequency signal is connected to Channel 2 (Fig. 2-28B). Fig. 2-28C shows the desired portion of the signal as displayed when common-mode rejection is used.

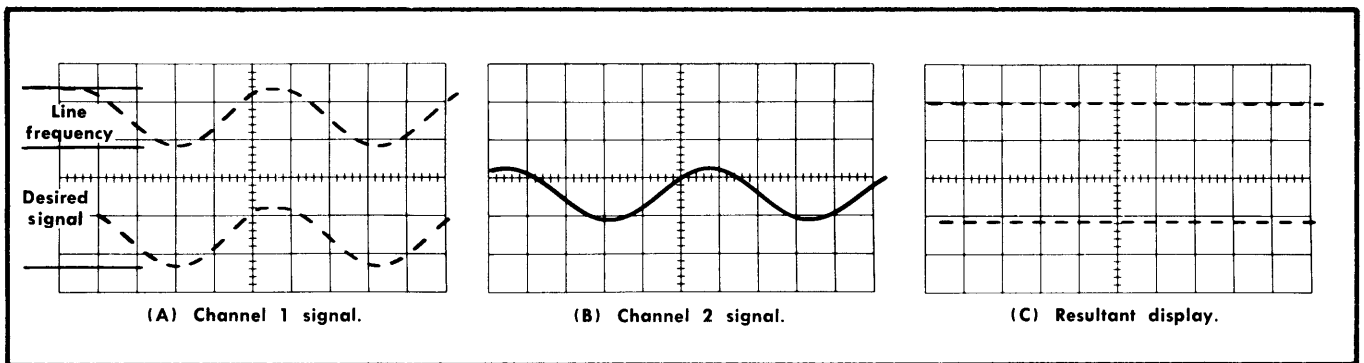

Fig. 2-28. Using the ADD feature for common-mode rejection. (A) Channel 1 signal contains desired information along with line-frequency component, (B) Channel 2 signal contains line-frequency only, (C) CRT display using common-mode rejection.

SECTION 3

CIRCUIT DESCRIPTION

Change information, if any, affecting this section is found at the rear of the manual.

Introduction

This section of the manual contains a description of the circuitry used in the Type 453 Oscilloscope. The description begins with a discussion of the instrument using the basic block diagram shown in Fig. 3-1. Then each circuit is described in detail using a detailed block diagram to show the interconnections between the stages in each major circuit and the relationship of the front-panel controls to the individual stages.

A complete block diagram is located in the Diagrams section at the rear of this manual. This block diagram shows the overall relationship between all of the circuits. Complete schematics of each circuit are also given in the Diagrams section. Refer to these diagrams throughout the following circuit description for electrical values and relationship.

BLOCK DIAGRAM

General

The following discussion is provided to aid in understanding the overall concept of the Type 453 before the individual circuits are discussed in detail. A basic block diagram of the Type 453 is shown in Fig. 3-1. Only the basic interconnections between the individual blocks are shown on this diagram. Each block represents a major circuit within this instrument. The number on each block refers to the complete circuit diagram which is located at the rear of this manual.

Signals to be displayed on the CRT are applied to either the Channel 1 INPUT and/or the Channel 2 INPUT connectors. The input signals are then amplified by the Channel 1 Vertical Preamp and/or the Channel 2 Vertical Preamp circuits. The VOLTS/DIV switch in each Vertical Preamp circuit provides attenuation, or switches gain, to provide the indicated deflection factor. Each Vertical Preamp circuit also includes separate position, input coupling, gain, variable attenuation and balance controls. A trigger-pickoff stage in the Channel 1 Vertical preamp circuit supplies a sample of the Channel 1 signal to the Trigger Preamp circuit or the CH 1 OUT connector. The output of both Vertical Preamp circuits is connected to the Vertical Switching circuit. This circuit selects the channel(s) to be displayed. An output signal from this circuit is connected to the Z Axis Amplifier circuit to blank out the between-channel switching transients when in the chopped mode of operation. A trigger-pickoff stage at the output of the Vertical Switching circuit provides a sample of the displayed signal(s) to the Trigger Preamp circuit.

The output of the Vertical Switching circuit is connected to the Vertical Output Amplifier through the Delay-Line

Driver stage and the Delay Line. The Vertical Output Amplifier circuit provides the final amplification for the signal before it is connected to the vertical deflection plates of the CRT. This circuit includes the TRACE FINDER switch which compresses the vertical and horizontal deflection within the viewing area to aid in locating an off-screen display.

The Trigger Preamp circuit provides amplification for the internal trigger signal selected by the TRIGGER switch. This internal trigger signal is selected from either the Channel 1 Vertical Preamp circuit or the Vertical Switching circuit. Output from this circuit is connected to the A Trigger Generator circuit and the B Trigger Generator circuit.

The A and B Trigger Generator circuits produce an output pulse which initiates the sweep signal produced by the A or B Sweep Generator circuits. The input signal to the A and B Trigger Generator circuits can be individually selected from the internal trigger signal from the Trigger Preamp circuit, an external signal applied to the EXT TRIG INPUT connector, or a sample of the line voltage applied to the instrument. Each trigger circuit contains level, slope, coupling and source controls.

The A Sweep Generator circuit produces a linear sawtooth output signal when initiated by the A Trigger Generator circuit. The slope of the sawtooth produced by the A Sweep Generator circuit is controlled by the A TIME/DIV switch. The operating mode of the A Sweep Generator circuit is controlled by the A SWEEP MODE switch. In the AUTO TRIG position, the absence of an adequate trigger signal causes the sweep to free run. In the NORM TRIG position, a horizontal sweep is presented only when correctly triggered by an adequate trigger signal. The SINGLE SWEEP position allows one (and only one) sweep to be initiated after the circuit is reset with the RESET button.

The B Sweep Generator circuit is basically the same as the A Sweep Generator circuit. However, this circuit only produces a sawtooth output signal after a delay time determined by the A TIME/DIV switch and the DELAY-TIME MULTIPLIER dial. If the B SWEEP MODE switch is set to the B STARTS AFTER DELAY TIME position, the B Sweep Generator begins to produce the sweep immediately following the selected delay time. If this switch is in the TRIGGERABLE AFTER DELAY TIME position, the B Sweep Generator circuit does not produce a sweep until it receives a trigger pulse from the B Trigger Generator circuit after the selected delay time.

The output of either the A or B Sweep Generator circuit is amplified by the Horizontal Amplifier circuit to produce horizontal deflection for the CRT in all positions of the HORIZ DISPLAY switch except EXT HORIZ. This circuit contains a 10 times magnifier to increase the sweep rate ten times in any A or B TIME/DIV switch position. Other horizontal deflection signals can be connected to the Horizontal

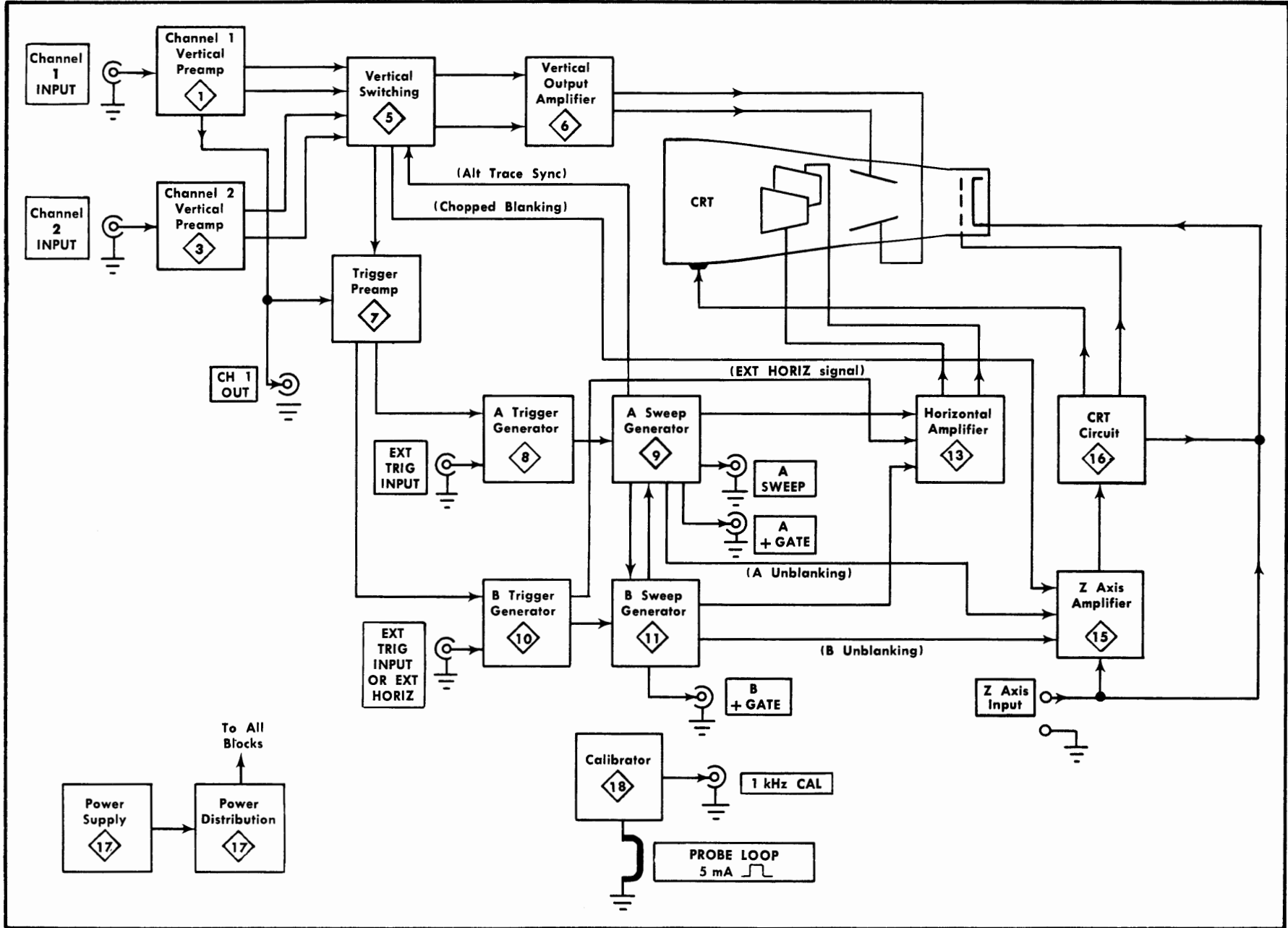

Fig. 3-1. Basic block diagram of the Type 453.

Amplifier by using the EXT HORIZ mode of operation. When the B SOURCE switch is set to INT, the X signal is connected to the Horizontal Amplifier circuit through the CH 1 Vertical Preamp circuit, the Trigger Preamp circuit and the B Trigger Generator circuit (HORIZ DISPLAY switch set to EXT HORIZ, B SOURCE switch set to INT and the TRIGGER switch set to CH 1 ONLY). In the EXT or EXT \div 10 position of the B SOURCE switch, the X signal is obtained from a signal connected to the B EXT TRIG INPUT or EXT HORIZ connector.

The Z Axis Amplifier circuit determines the CRT intensity and blanking. The Z Axis Amplifier circuit sums the current inputs from the INTENSITY control, Vertical Switching circuit (chopped blanking), A and B Sweep Generator circuits (unblanking) and the external Z AXIS INPUT binding post. The output level of the Z Axis Amplifier circuit controls the trace intensity through the CRT Circuit. The CRT Circuit provides the voltages and contains the controls necessary for the operation of the cathode-ray tube.

The Power Supply circuit provides the low-voltage power necessary for operation of this instrument. This voltage is distributed to all of the circuits in the instrument as shown by the Power Distribution diagram. The Calibrator circuit produces a square-wave output with accurate amplitude and frequency which can be used to check the calibration of the instrument and the compensation of probes. The PROBE LOOP provides an accurate current source for calibration of current-measuring probe systems.

CIRCUIT OPERATION

General

The following circuit analysis is written around the detailed block diagrams which are given for each major circuit. These detailed block diagrams give the names of the individual stages within the major circuits and show how they are connected together. The block diagrams also show the inputs and outputs for each major circuit and the relationship of the front-panel controls to the individual stages. The circuit diagrams from which the detailed block diagrams are derived are shown in the Diagrams section of this manual. The names assigned to the individual stages on the detailed block diagrams are used throughout the following discussion.

This section describes the electrical operation and relationship of the circuits in the Type 453. The theory of operation for circuits which are used only in this instrument are described in detail in this discussion. Circuits which are commonly used in the electronics industry are not described in detail. Instead, references are given to textbooks or other source material which describe the complete operation of these circuits.

CHANNEL 1 VERTICAL PREAMP

General

Input signals for vertical deflection on the CRT can be connected to the channel 1 INPUT connector. In the EXT HORIZ mode of operation, this input signal provides the horizontal (X-axis) deflection (HORIZ DISPLAY switch set to

EXT HORIZ, B SOURCE switch set to INT and TRIGGER switch set to CH 1 ONLY). The Channel 1 Vertical Preamp circuit provides control of input coupling, vertical deflection factor, balance, vertical position and vertical gain. It also contains a stage to provide a sample of the Channel 1 input signal to the Trigger Preamp circuit to provide internal triggering from the Channel 1 signal only. Fig. 3-2 shows a detailed block diagram of the Channel 1 Vertical Preamp circuit. A schematic of this circuit is shown on diagram 1 at the rear of this manual.

Input Coupling

Input signals applied to the Channel 1 INPUT connector can be AC-coupled, DC-coupled or internally disconnected. When the Input Coupling switch, SW1, is in the DC position, the input signal is coupled directly to the Input Attenuator stage. In the AC position, the input signal passes through capacitor C1. This capacitor prevents the DC component of the signal from passing to the amplifier. The GND position opens the signal path and the input to the amplifier is connected to ground. This provides a ground reference without the need to disconnect the applied signal from the INPUT connector. Resistor R2, connected across the Input Coupling switch, allows C1 to be precharged in the GND position so the trace remains on screen when switched to the AC position with a high DC level applied.

Input Attenuator

The effective overall Channel 1 deflection factor of the Type 453 is determined by the CH 1 VOLTS/DIV switch. In all positions of the CH 1 VOLTS/DIV switch above 20 mV, the basic deflection factor of the Vertical Deflection System is 20 millivolts per division of CRT deflection. To increase this basic deflection factor to the values indicated on the front panel, precision attenuators are switched into the circuit. In the 5 and 10 mV positions, input attenuation is not used. Instead, the gain of the Feedback Amplifier is changed to decrease the deflection factor (see Feedback Amplifier discussion).

For the CH 1 VOLTS/DIV switch positions above 20 mV, the attenuators are switched into the circuit singly or in pairs to produce the vertical deflection factor indicated on the front panel. These attenuators are frequency-compensated voltage dividers. For DC and low-frequency signals, they are primarily resistance dividers and the voltage attenuation is determined by the resistance ratio in the circuit. The reactance of the capacitors in the circuit is so high at low frequencies that their effect is negligible. However, at higher frequencies, the reactance of the capacitors decreases and the attenuator becomes primarily a capacitance voltage divider.

In addition to providing constant attenuation at all frequencies within the bandwidth of the instrument, the Input Attenuators are designed to maintain the same input RC characteristics (one megohm \times 20 pF) for each setting of the CH 1 VOLTS/DIV switch. Each attenuator contains an adjustable series capacitor to provide correct attenuation at high-frequencies and an adjustable shunt capacitor to provide correct input capacitance.

Input Stage

The Channel 1 signal from the Input Attenuator is connected to the Input Stage through the network C17-C18-C20-R16-R17-R18-R19-R20-R21. R16, R17 and R20 provide the input resistance for this stage. These resistors are part of the attenuation network at all CH 1 VOLTS/DIV switch positions. Variable capacitor C17 adjusts the basic input time constant for a nominal value of one megohm \times 20 pF. The divider action of R16-R17-R20 allows about 98% of DC and low-frequency signals to pass to the gate of FET (field-effect transistor) Q23A. C18 with the stray capacitance in the circuit forms an AC divider which maintains this same voltage division for high-frequency signals. R18 limits the current drive to the gate of Q23A. Diode D18 protects the circuit by clamping the gate of Q23A at about -12.5 volts if a high-amplitude negative signal is applied to the Channel 1 INPUT connector. Over-voltage protection for high-amplitude positive signals is provided by forward conduction of Q23A. The current path is through R23, L23, D36 and D37.

FET Q23B is a constant current source for Q23A and also provides temperature compensation for Q23A. The STEP ATTEN BAL adjustment, R30, varies the gate level of Q23B to provide a zero-volt level at the emitter of Q34 with no signal applied. With a zero-volt level at the emitter of Q34, the trace position will not change when switching between the 5, 10 and 20 mV positions of the CH 1 VOLTS/DIV switch.

DC and low-frequency signals are connected from the source of Q23A to the Feedback Amplifier through R23, L23, Q33 and R39.

L23 isolates the base of Q33 from the source of FET Q23A. Diodes D34-D35 and D36-D37 limit the dynamic range of the signal at the base of Q33 and prevent the following stages from being damaged by a large voltage swing at the source of Q23A. The signal path for high-frequency signals is through C23, Q43 and C39. High-frequency signals at the emitter of Q43 are connected to the base of Q33 through C38. This allows Q33 to be driven at high frequencies while preventing the base circuitry of Q33 from capacitively loading the input FET, Q23A. C38 is selected to provide the same amplitude AC and DC signal at the base of Q33. C24 couples high-frequency information to the junction of R25-R26, thereby reducing the loading at the base of Q43.

Feedback Amplifier

The Feedback Amplifier, Q34 and Q54, changes the overall gain of the Channel 1 Vertical Preamp to provide the correct deflection factor in the 5 and 10 mV positions of the CH 1 VOLTS/DIV switch. Gain of this stage is determined by the ratio of R46-R50 to R43, R44 or R45. In the 5 mV position of the CH 1 VOLTS/DIV switch, the network C43A-C43B-C43C-C43D-C43E-L43A-R43A-R43C-R43E is connected into the emitter circuit of Q34. The ratio between R46-R50 and R43 provides a gain of about 10. C43A, C43C, L43A and R43C are adjustable to provide high-frequency peaking for the network. In the 10 mV position, conditions are the same except that the network C44A-C44B-C44C-L44A-R44A-R44B-R44C is connected into the circuit in place of the previous network. The ratio between R46-R50 and R44 provides a gain of about 5 times in this CH 1 VOLTS/DIV switch position. C44A, C44C and R44C provide high frequency peaking for this network. In the 20 mV and higher CH 1 VOLTS/DIV switch

positions, the gain of the Feedback Amplifier is about 2.5 as established by the ratio between R46-R50 and R45. Adjustable capacitor C45A provides high-frequency peaking for the Feedback Amplifier stage. C49 and R49 provide high-frequency damping for the circuit. As mentioned previously, the STEP ATTEN BAL adjustment is set to provide zero volts at the emitter of Q34 when the input is at zero volts. Since there is no voltage difference across the emitter resistors, R43, R44 or R45, changing the value of the resistance does not change the current in the circuit. Therefore, the trace position does not change when switching between the 5 mV, 10 mV and 20 mV positions of the CH 1 VOLTS/DIV switch if the STEP ATTEN BAL control is correctly adjusted.

Vertical position of the trace is determined by the setting of the POSITION control, R40. This control changes the current into the emitter of Q34, a low-impedance point, which results in negligible voltage change at this point. However, the change in current from the POSITION control produces a resultant DC voltage at the output of the Feedback Amplifier stage to change the vertical position of the trace. The CH 1 Position Center adjustment, R55, is adjusted to provide a centered display when the Channel 1 POSITION control is centered (with a zero-volt DC input level).

Zener diode D53 provides a low-impedance source for Q54. Variable capacitor C54 provides feedback from the collector to the base of Q54 for amplifier stabilization. The output signal from the Feedback Amplifier stage is connected to the Paraphrase Amplifier stage and the Channel 1 Trigger Pickoff stage.

Channel 1 Trigger Pickoff

The signal at the collector of Q54 in the Feedback Amplifier stage is connected to the Channel 1 Trigger Pickoff stage through D58 and R59. This sample of the Channel 1 input signal provides internal triggering from the Channel 1 signal or X-axis deflection for EXT HORIZ operation. Q63 is connected as an emitter follower to provide isolation between the Trigger Preamp circuit and the Feedback Amplifier stage. It also provides a minimum load for the Feedback Amplifier stage and a low output impedance to the Trigger Preamp circuit. D58 provides thermal compensation for Q63. The CH 1 Trigger DC Level adjustment, R60, adjusts the DC level at the base of Q63 for a zero-volt DC output level from the Trigger Preamp circuit when the Channel 1 trace is centered vertically. Output from the Channel 1 Trigger Pickoff stage is connected to the Trigger Preamp circuit through the TRIGGER switch, SW230B.

Paraphase Amplifier

The output signal from the Feedback Amplifier stage is connected to the Paraphase Amplifier stage through the VARIABLE control, R75. When the VARIABLE control is set to the CAL position (fully clockwise), R75 is effectively by-passed and maximum signal current reaches the base of Q84. Switch SW75, ganged with the VARIABLE control, is open and the UNCAL neon bulb is disconnected. As the VARIABLE control is rotated counterclockwise from the CAL detent, SW75 is closed and the UNCAL light, B75, ignites to indicate that the vertical deflection is uncalibrated. The signal applied to the base of Q84 is continuously reduced as the VARIABLE control is rotated counterclockwise.

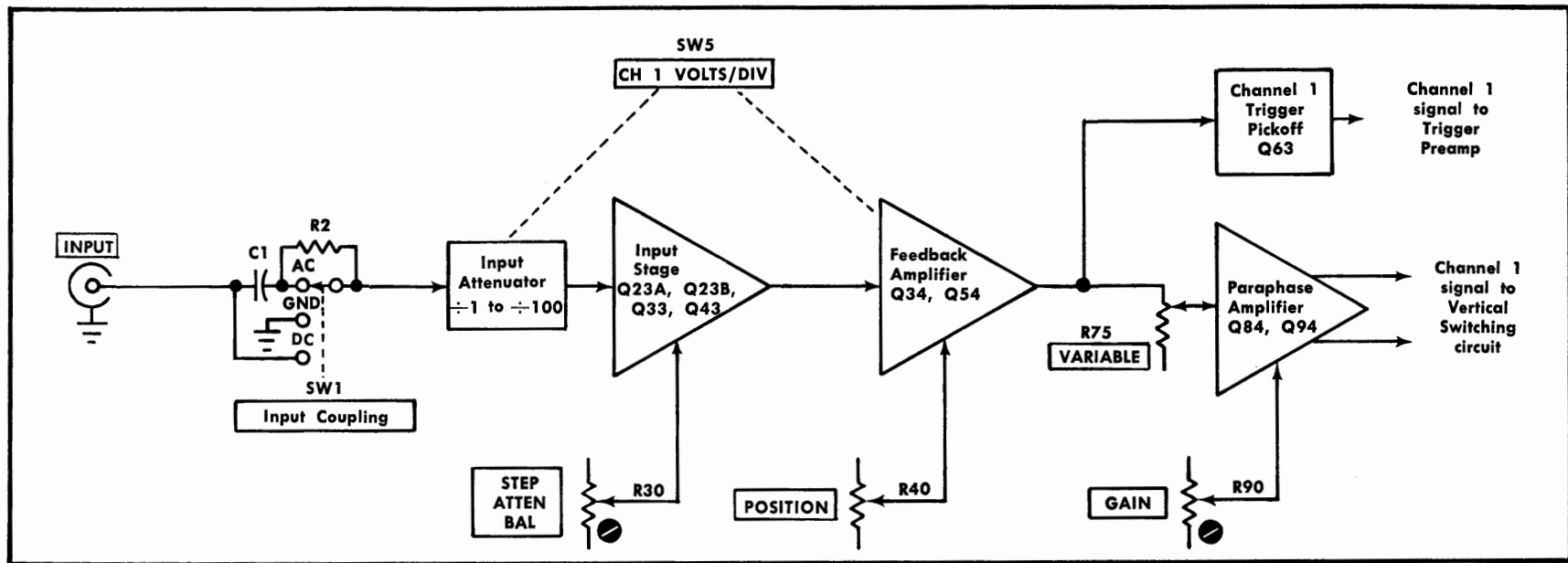

Fig. 3-2. Channel 1 Vertical Preamp detailed block diagram.

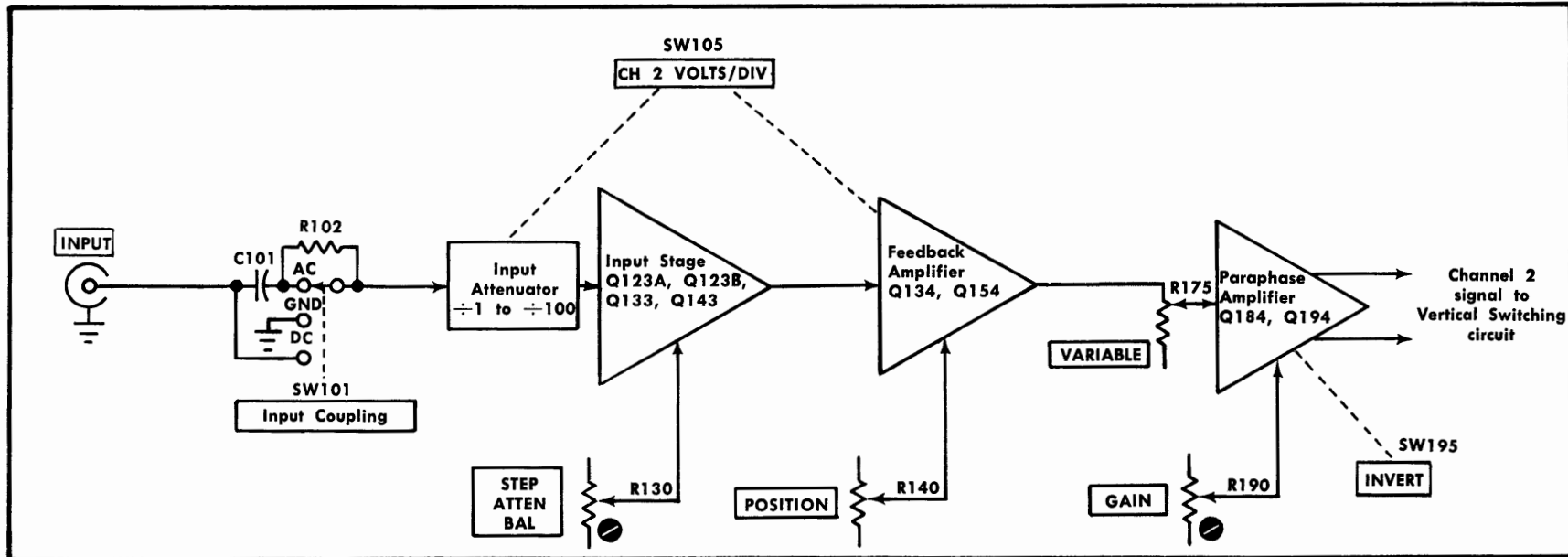

Fig. 3-3. Channel 2 Vertical Preamp detailed block diagram.

Circuit Description—Type 453/R453

Q84 and Q94 are connected as a common-emitter phase inverter (paraphase amplifier)¹ to convert the single-ended input signal to a push-pull output signal. Gain of this stage is determined by the emitter degeneration. As the resistance between the emitters of Q84 and Q94 increases, emitter degeneration increases also to result in less gain through the stage. The GAIN adjustment, R90, varies the resistance between the emitters to control the overall gain of the Channel 1 Vertical Preamp.

CHANNEL 2 VERTICAL PREAMP

General

The Channel 2 Vertical Preamp circuit is basically the same as the Channel 1 Vertical Preamp circuit. Only the differences between the two circuits are described here. Portions of this circuit not described in the following description operate in the same manner as for the Channel 1 Vertical Preamp circuit (corresponding circuit numbers assigned in the 100-199 range). Fig. 3-3 shows a detailed block diagram of the Channel 2 Vertical Preamp circuit. A schematic of this circuit is shown in diagram 3 at the rear of this manual.

Feedback Amplifier

Basically, the Channel 2 Feedback Amplifier operates as described for Channel 1. However, the Channel 2 Vertical

¹Lloyd P. Hunter (ed.), "Handbook of Semiconductor Electronics", second edition, McGraw-Hill, New York, pp. 11-94.

Preamp circuit does not have a trigger pickoff stage. To provide a load at the collector of Q154 similar to the load the Channel 1 Trigger Pickoff stage provides at the collector of Q54, C159 and R159 are connected into the circuit.

Paraphase Amplifier

The basic Channel 2 Paraphase Amplifier configuration and operation is the same as for Channel 1. However, the INVERT switch, SW195, has been added in the Channel 2 circuit. This switch allows the displayed signal from Channel 2 to be inverted.

VERTICAL SWITCHING

General

The Vertical Switching circuit determines if the CH 1 and/or the CH 2 Vertical Preamp output signal is connected to the Vertical Output Amplifier circuit (through the Delay Line Driver and Delay Line stages). In the ALT and CHOP positions of the MODE switch, both channels are alternately displayed on a shared-time basis. Fig. 3-4 shows a detailed block diagram of the Vertical Switching circuit. A schematic of this circuit is shown on diagram 5 at the rear of this manual.

Diode Gates

The Diode Gates, consisting of four diodes each, can be thought of as switches which allow either of the Vertical

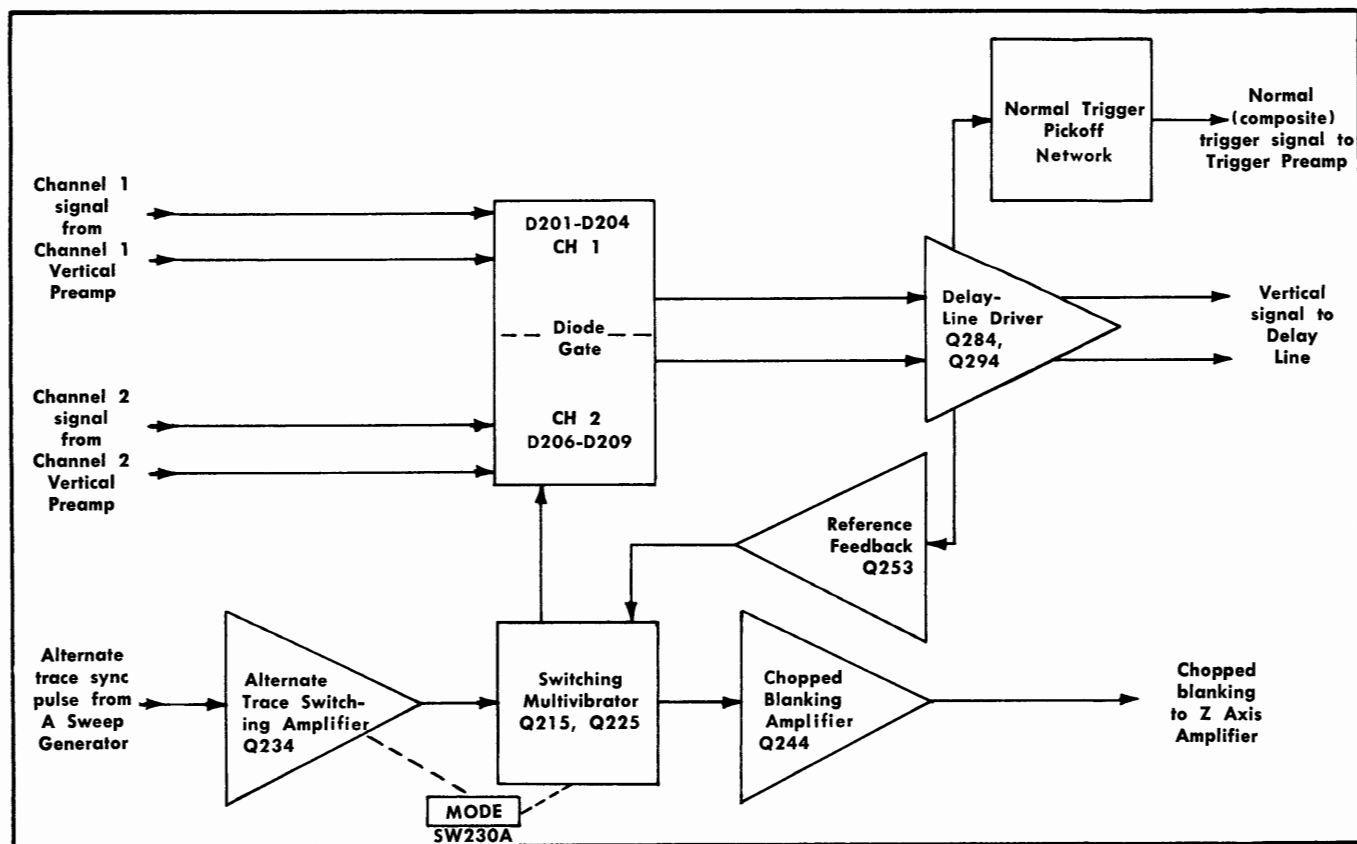

Fig. 3-4. Vertical Switching detailed block diagram.

Preamp output signals to be coupled to the Vertical Output Amplifier. D201 through D204 control the Channel 1 output and D206 through D209 control the Channel 2 output. These diodes are in turn controlled by the Switching Multivibrator for dual-trace displays, or by the MODE switch for single-trace displays.

CH 1. In the CH 1 position of the MODE switch, -12 volts is applied to the junction of D207-D208 in the Channel 2 Diode Gate through R227 (see simplified diagram in Fig. 3-5). This forward biases D207-D208 and reverse biases D206-D209 since the input to the Delay-Line Driver stage is at about -5.8 volts. D206-D209 block the Channel 2 signal so it cannot pass to the Delay-Line Driver stage. At the same time, in the Channel 1 Diode Gate, D202-D203 are connected to ground through R212. D202-D203 are held reverse biased while D201-D204 are forward biased. Therefore, the Channel 1 signal passes to the Delay-Line Driver stage.

CH 2. In the CH 2 position of the MODE switch, the above conditions are reversed. D202-D203 are connected to -12 volts through R217 and D207-D208 are connected to ground through R222. The Channel 1 Diode Gate blocks the signal and the Channel 2 Diode Gate allows it to pass.

Switching Multivibrator

ALT. In this mode of operation, the Switching Multivibrator operates as a bistable multivibrator.² In the ALT position of the MODE switch, -12 volts is applied to the emitter of the Alternate Trace Switching Amplifier stage, Q234 by the MODE switch. Q234 is forward biased to supply current to the "on" Switching-Multivibrator transistor through R234 and D218 or D228. For example, if Q225 is conducting, current is supplied to Q225 through D228. The current flow through collector resistors R221 and R222 drops the D207-D208 cathode level negative so the Channel 2 Diode Gate is blocked as for Channel 1 only operation. The signal passes through the Channel 1 Diode Gate to the Delay-Line Driver stage.

The Alternate-trace sync pulse is applied to Q234 at the end of each sweep. This negative-going sync pulse momentarily interrupts the current through Q234 and both Q215 and Q225 are turned off. When Q234 turns on again after the alternate-sync pulse, the charge on C218 determines whether Q215 or Q225 conducts. For example, when Q225 was conducting, C218 was charged negatively on the D218 side to the emitter level of Q215, and positively on the D228 side. This charge is stored while Q234 is off and holds the emitter of Q215 more negative than the emitter of Q225. When both Q215 and Q225 were off, the voltage at their bases became approximately equal. Now when Q234 comes back on, the transistor with the most negative emitter will start conducting first with the resulting negative movement at its collector holding the other transistor off. The conditions described previously are reversed; now the Channel 1 Diode Gate is reversed biased and the Channel 2 signal passes through the Channel 2 Diode Gate.

The Reference Feedback stage, Q253, provides common-mode voltage feedback from the Delay-Line Driver stage to allow the diode gates to be switched with a minimum amplitude switching signal. The emitter level of Q253 is connected to the junction of the Switching Multivibrator collector

²Jacob Millman and Herbert Taub, "Pulse, Digital and Switching Waveforms" McGraw-Hill, New York, 1965, pp. 362-389.

resistors, R211-R212 and R221-R222 through D213 or D223. The collector level of the "on" Switching Multivibrator transistor is negative and either D213 or D223 is forward biased. This clamps the cathode level of the forward-biased shunt diodes in the applicable Diode Gate about 0.5 volts more negative than the emitter level of Q253. The shunt diodes are clamped near their switching level and therefore they can be switched very fast with a minimum amplitude switching signal. The level at the emitter of Q253 follows the average voltage level at the emitters of the Delay-Line Driver stage. This maintains about the same voltage difference across the Diode Gate shunt diodes so they can be switched with a minimum amplitude switching signal regardless of the deflection signal at the anodes of the shunt diodes.

CHOP. In the CHOP position of the MODE switch, the Switching Multivibrator free runs as an astable multivibrator³ at about a 500-kHz rate. The emitters of Q215 and Q225 are connected to -12 volts through R218 and R228. At the time of turn-on, one of the transistors begins to conduct; for example, Q225. Q225 conducts the Channel 2 current and prevents the Channel 2 signal from reaching the Delay-Line Driver stage. Meanwhile, the Channel 1 Diode Gate passes the Channel 1 signal to the Delay-Line Driver.

The frequency-determining components in the CHOP mode are C218-R218-R228. Switching action occurs as follows: When Q225 is on, C218 attempts to charge to -12 volts through R218. The emitter of Q215 slowly goes toward -12 volts as C218 charges. The base of Q215 is held at a negative point determined by voltage divider R215-R224 between -12 volts and the collector of Q225. When the emitter voltage of Q215 reaches a level slightly more negative than its base, Q215 conducts. The collector level of Q215 goes negative and pulls the base of Q225 negative also, through divider R214-R225, to cut Q225 off. When Q215 turns on, its emitter is pulled positive along with C218. This action switches the Diode Gate stage to connect the opposite half to the Delay-Line Driver stage. Again C218 begins to charge towards -12 volts but this time through R228. The emitter of Q225 slowly goes negative as C218 charges, until Q225 turns on. Q215 shuts off and the cycle begins again.

Diodes D218 and D228 have no effect in the CHOP mode. Q253 operates the same in CHOP as in ALT, to allow the Diode Gates to be switched with a minimum signal level.

The Chopped Blanking Amplifier stage, Q244, provides an output pulse to the Z Axis Amplifier which blanks out the transition between the Channel 1 trace and the Channel 2 trace. When the Switching Multivibrator changes states, the current through T241 momentarily changes. A negative pulse is applied to the base of Q244, to turn it off. The width of the pulse at the base of Q244 is determined by R241 and C241. Q244 clips the signal applied to its base, and the positive-going output pulse, which is coincident with trace switching, is applied to the Z Axis Amplifier circuit through R245.

ADD. In the ADD position of the MODE switch, the Diode Gate stage allows both signals to pass to the Delay-Line Driver stage. The Diode Gates are both held on by -12 volts applied to their cathodes through R260 and R270. Since both signals are applied to the Delay-Line Driver stage, the output signal is the algebraic sum of the signals on both Channel 1 and 2.

³Ibid., pp. 438-451.

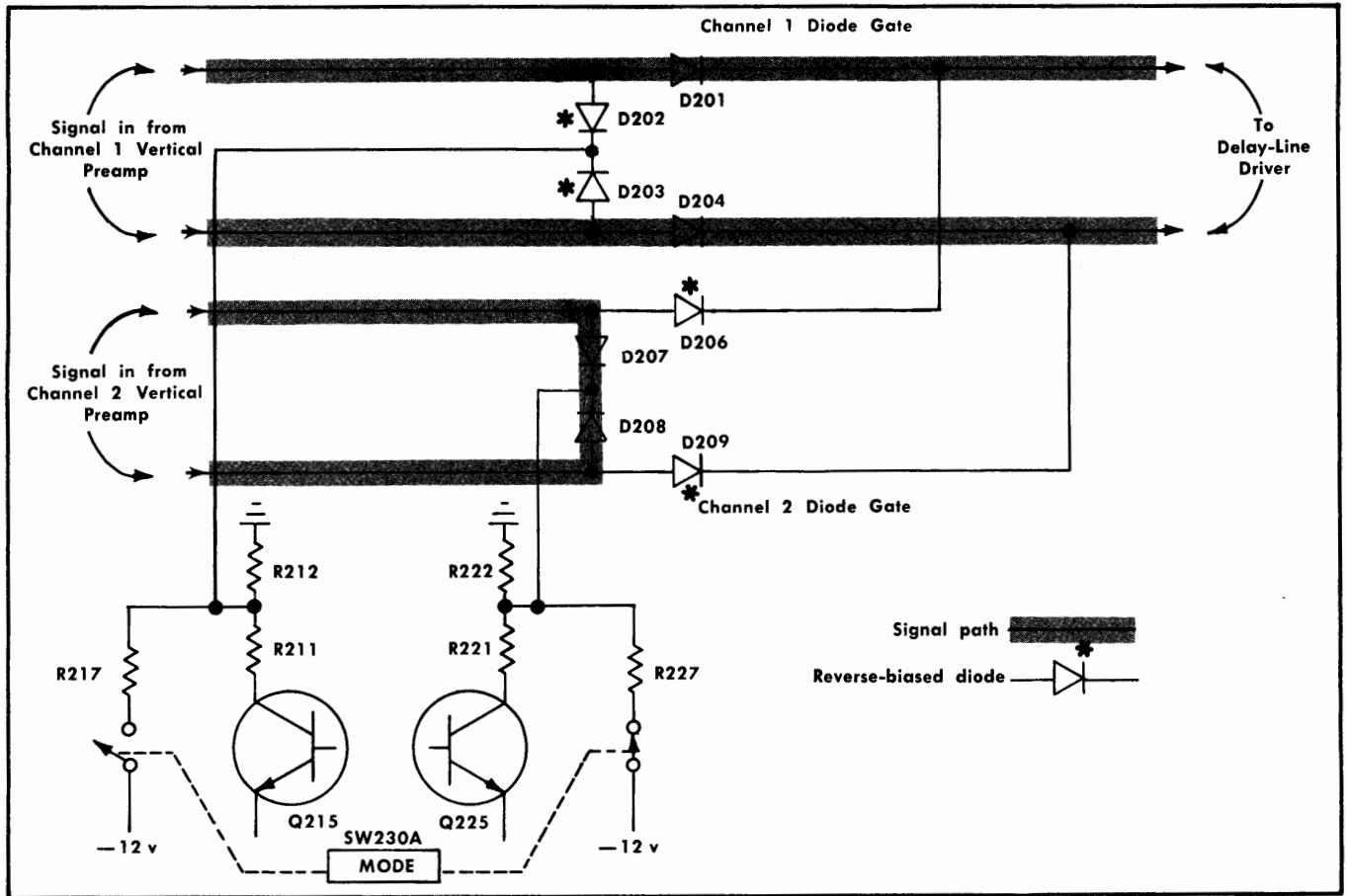

Fig. 3-5. Effect of Diode Gates on signal path (simplified Vertical Switching diagram). Conditions shown for CH 1 position of MODE switch.

Delay-Line Driver

Output of the Diode Gate stage is applied to the Delay-Line Driver stage, Q284 and Q294. Q284 and Q294 are connected as operational amplifiers with feedback provided by R268-R269 and R278-R279 and the delay-line compensation network. The delay-line compensation network, C261-C262-C263-C264-C265-C266-R261-R262-R264-R265, provides high-frequency compensation for the Delay Line. R289-C289 in the collector circuit of Q284-Q294 improve the high-frequency reverse termination of the Delay Line. Output of the Delay-Line Driver stage is connected to the Vertical Output Amplifier through the Delay Line.

Normal Trigger Pickoff Network

The trigger signal for NORM trigger operation is obtained from the collector of Q284. The Normal Trigger DC Level adjustment, R285, sets the DC level of the normal trigger output signal so the sweep is triggered at the zero-level of the displayed signal when the Triggering LEVEL control is set to 0. The normal trigger signal is connected to the Trigger Preamp through SW230B. R294 and R295 provide the same DC load for Q294 as provided to Q284 by the Normal Trigger Pickoff Network.

VERTICAL OUTPUT AMPLIFIER

General

The Vertical Output Amplifier circuit provides the final amplification for the vertical deflection signal. This circuit includes the Delay Line and the TRACE FINDER switch. The TRACE FINDER switch compresses an overscanned display within the viewing area when pressed in. Fig. 3-6 shows a detailed block diagram of the Vertical Output Amplifier circuit. A schematic of this circuit is shown on diagram 6 at the rear of this manual.

Delay Line

The Delay Line provides approximately 140 nanoseconds delay for the vertical signal to allow the Sweep Generator circuits time to initiate a sweep before the vertical signal reaches the vertical deflection plates. This allows the instrument to display the leading edge of the signal originating the trigger pulse when using internal triggering.

Phase Equalizer Network

The Phase Equalizer Network is comprised of L301-L302-L311-C301-C302-C311-C312. This network compensates for

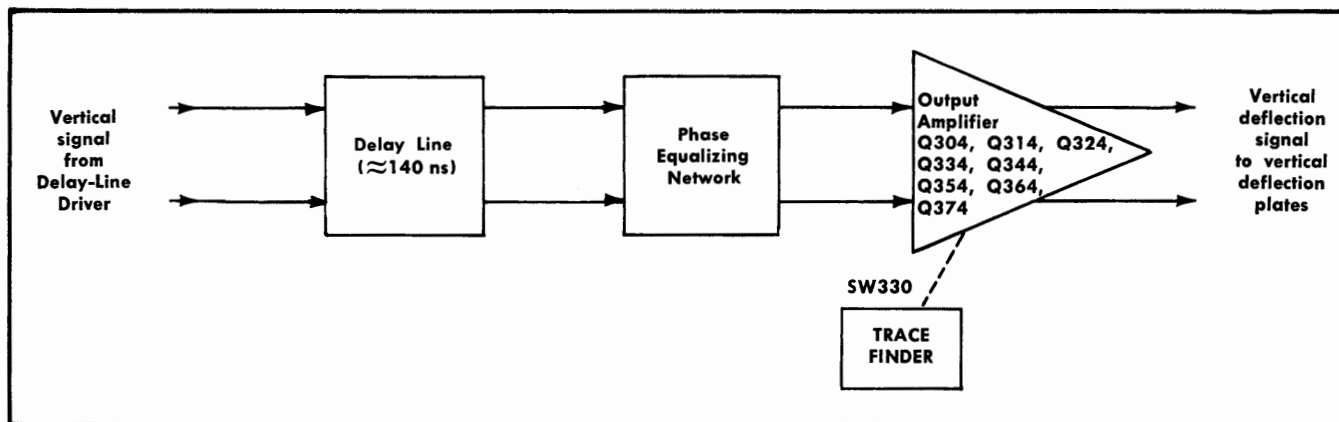

Fig. 3-6. Vertical Output Amplifier detailed block diagram.

the phase distortion of the Delay Line. C303-R303 and C313-R313 in series with the base-emitter resistance of Q304 and Q314 provide the forward termination for the Delay Line.

Output Amplifier

Q304 and Q314 are connected as common-base amplifiers to provide a low input impedance to properly terminate the Delay Line (along with the Phase Equalizer Network). It also provides isolation between the Delay Line and the following stages.

The output of Q304 and Q314 is connected to the bases of Q324 and Q334. The network C326-C327-C328-C336-R328 provides high-frequency peaking to compensate for the capacitive loading of the deflection plates on the output stage. C328, C336 and R328 are adjustable to provide optimum response. The TRACE FINDER switch, SW330, reduces the quiescent current of Q324 and Q334, when pressed, to compress an off-screen display within the graticule area. Normally, the collector current for Q324 and Q334 is supplied through R321, R322 and the parallel combination of R323 and R333. When SW330 is pressed, -12-volts is connected to the collector circuit of Q324 and Q334 through R332. This limits the dynamic range of Q324 and Q334 to compress the display vertically within the graticule area. Although the display is nonlinear, it provides a method of locating a signal that is off screen vertically due to incorrect positioning or deflection factor.

Q344 and Q354 amplify the output of Q324 and Q334. The signal at the collectors of Q344 and Q354 is applied to the output transistors, Q364 and Q374, through R344, R354 and T357. D344 and D354 prevent saturation of Q344 and Q354 (to improve the recovery of the Vertical Output Amplifier circuit) when large signals deflect the display off screen. T357 provides high-frequency balance for the Output Amplifier stage. Q364 and Q374 provide the output signal voltage to drive the CRT vertical deflection plates. LR367 and LR377 provide damping for the leads connecting the output signal to the deflection plates.

TRIGGER PREAMP

General

The Trigger Preamp circuit amplifies the internal trigger signal to the level necessary to drive the A and B Trigger

Generator circuits. Input signal for the Trigger Preamp circuit is either a sample of the signal applied to Channel 1 or a sample of the composite vertical signal from the Vertical Switching circuit. Fig. 3-7 shows a detailed block diagram of the Trigger Preamp circuit. A schematic of this circuit is shown in diagram 7 at the rear of this manual.

Input Circuitry

The internal trigger signal from the Vertical Deflection System is connected to the Trigger Preamp through the TRIGGER switch, SW230B. When the TRIGGER switch is in the NORM position, the trigger signal is a sample of the composite vertical signal in the Vertical Switching circuit. This signal is obtained from the collector of Q284 and is a sample of the displayed channel (or channels for dual-trace operation). Since the signal source follows the dual-trace switching stage, the NORM trigger signal also includes the chopped switching transients when operating in the CHOP mode. When the TRIGGER switch is in the NORM position, the CH 1 lights, B400 and B401, are disconnected. Also, the sample of the Channel 1 signal is connected to the CH 1 OUT connector. This output signal can be used to monitor Channel 1 or it can be used to cascade with Channel 2 to provide a one millivolt/division minimum deflection factor (with reduced bandwidth).

In the CH 1 ONLY position of the TRIGGER switch, the internal trigger signal is obtained from the emitter of Q63 in the CH 1 Vertical Preamp circuit. Now, the internal trigger signal is a sample of only the signal applied to the Channel 1 INPUT connector. The CH 1 lights are turned on to indicate that the TRIGGER switch is in the CH 1 ONLY position and the CH 1 OUT connector is disconnected from the circuit.

R402, R403 and R404 terminate the coaxial cables from the trigger pickoff stages to provide a constant load for these stages. In the NORM position of the TRIGGER switch, the NORM trigger signal (from the Vertical Switching circuit) is terminated at the input to the amplifier by R404. The CH 1 ONLY trigger signal (from the CH 1 Vertical Preamp circuit) is terminated at the CH 1 OUT connector by R402. In the CH 1 ONLY position, the CH 1 ONLY trigger signal is terminated at the input to the amplifier by R404 and the NORM trigger signal is terminated by R403.

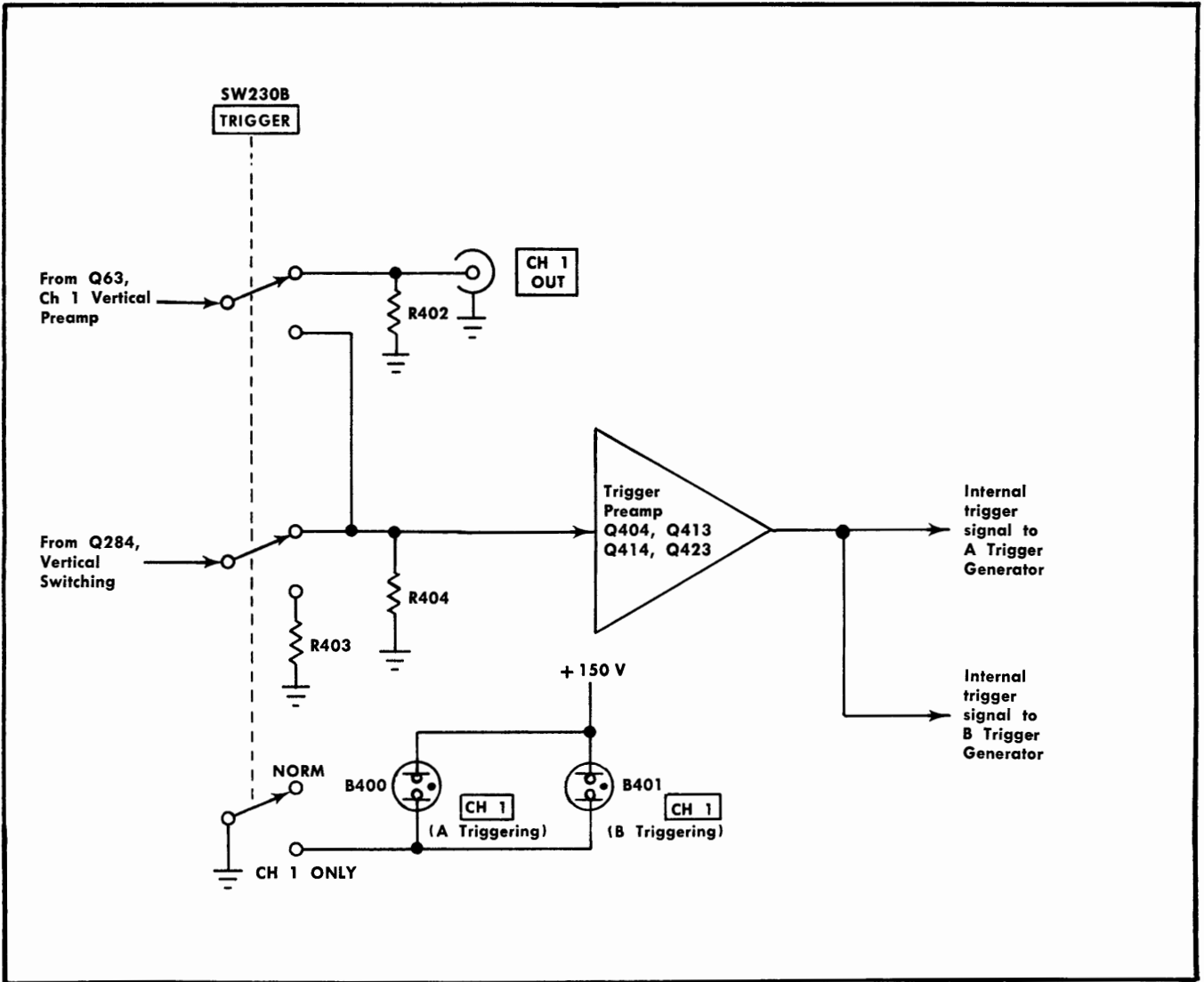

Fig. 3-7. Trigger Preamp detailed block diagram.

Amplifier Circuitry

The internal trigger signal selected by the TRIGGER switch is connected to the base of Q404. Transistor Q404 converts the trigger voltage signal at its base to a current drive for the remainder of the Trigger Preamp. D408 in the emitter circuit of Q404 provides thermal compensation for the amplifier.

The signal current at the collector of Q404 is connected to the base of Q414. Q413, Q414 and Q423 are connected as a current driven, voltage output operational amplifier. The amplified signal at the collector of Q414 is connected directly to the base of Q413, and to the base of Q423 through zener diode D421. This zener diode provides a DC voltage drop while the signal is connected to the base of Q423 with minimum attenuation. Q413 and Q423 are connected as emitter followers in the complementary symmetry amplifier⁴ configuration. This configuration overcomes the basic limitation of emitter followers; inability to provide equal response to

both positive- and negative-going portions of a signal. This is remedied in this configuration by using an NPN transistor for one emitter follower, Q413, and a PNP transistor for the other emitter follower, Q423. Since Q413 is an NPN transistor, it responds best to positive-going signals and Q423, being a PNP transistor responds best to negative-going signals. The result is a circuit which has equally fast response to both positive- and negative-going trigger signals while maintaining a low output impedance. Feedback from the output of the Trigger Preamp circuit is connected to the base of Q414 through R419. This feedback provides more linear operation. Total overall gain of the Trigger Preamp is about 10. The amplified internal trigger signal is connected to the A and B SOURCE switches through R427 and R429.

A TRIGGER GENERATOR

General

The A Trigger Generator circuit produces trigger pulses to start the A Sweep Generator circuit. These trigger pulses

⁴Lloyd P. Hunter, pp. 11-57—11-62.

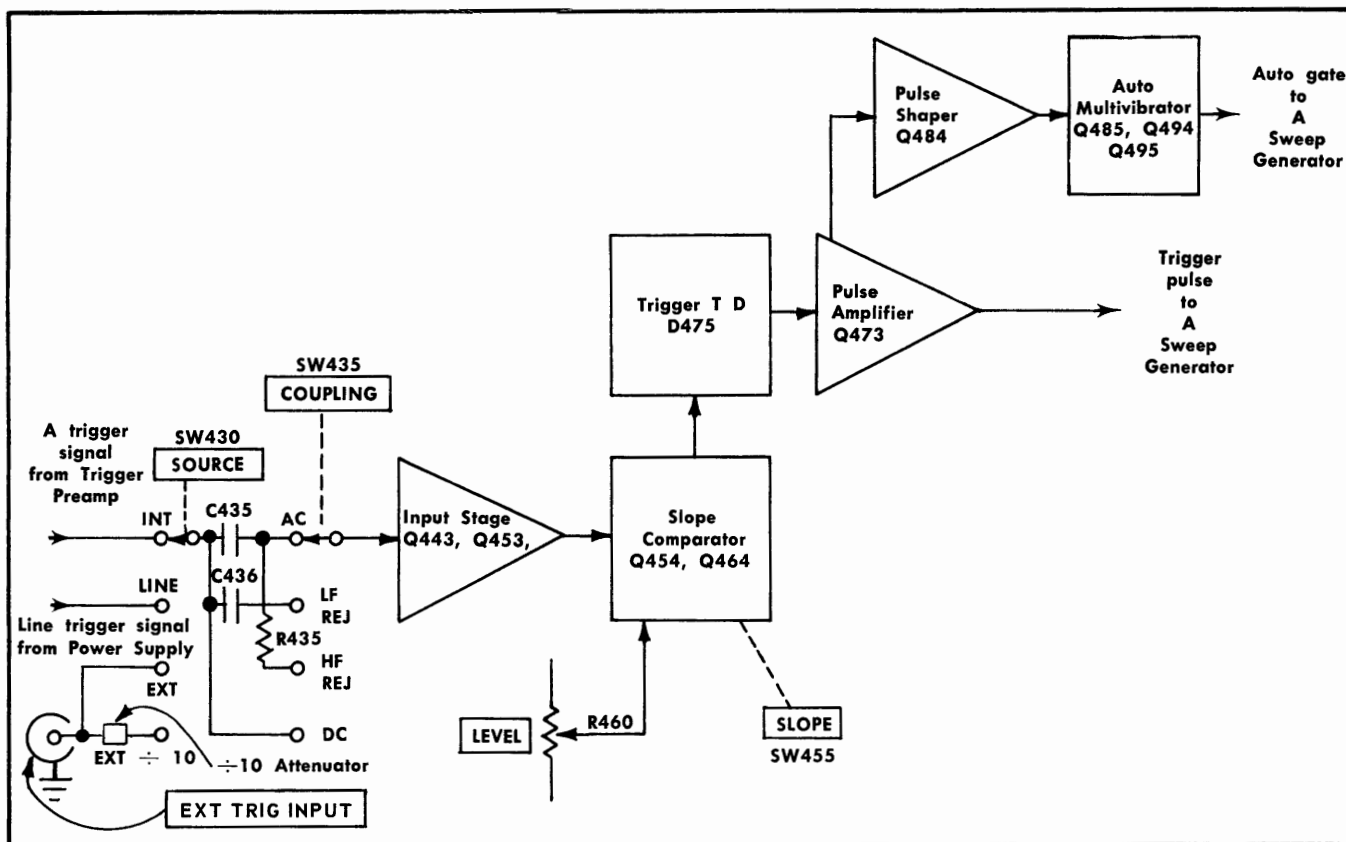

Fig. 3-8. A Trigger Generator detailed block diagram.

are derived either from the internal trigger signal from the Vertical Deflection System, an external signal connected to the EXT TRIG INPUT connector, or a sample of the line voltage applied to the instrument. Controls are provided in this circuit to select trigger level, slope, coupling and source. Fig. 3-8 shows a detailed block diagram of the A Trigger Generator circuit. A schematic of this circuit is shown on diagram 8 at the rear of this manual.

Trigger Source

The A SOURCE switch, SW430, selects the source of the A trigger signal. Three trigger sources are available; internal, line and external. A fourth position of the A SOURCE switch provides 10 times attenuation for the external trigger signal.

The internal trigger signal is obtained from the Vertical Deflection System through the Trigger Preamp circuit. This signal is a sample of the signal(s) applied to the Channel 1 and/or Channel 2 INPUT connectors. Further selection of the internal trigger source is provided by the TRIGGER switch to provide the internal trigger signal from both channels or from Channel 1 only (see Trigger Preamp discussion for details).

The line trigger is obtained from voltage divider R1104-R1105 in the Power Supply circuit. This sample of the line frequency, about 1.5 volts RMS, is coupled to the A Trigger Generator in the LINE position of the A SOURCE switch. The

A COUPLING switch should not be in the LF REJ position when using this trigger source.

External trigger signals applied to the A EXT TRIG INPUT connector can be used to produce a trigger in the EXT ÷ 10 positions of the A SOURCE switch. Input resistance (DC) is about one megohm in both external positions. However, in the LF REJ position of the A COUPLING switch, the medium and high-frequency resistance drops to about 90 kilohms due to the addition of C436-R436 in the circuit. In the EXT ÷ 10 position, a 10 times frequency compensated attenuator is connected into the input circuit. This attenuator reduces the input signal amplitude 10 times to provide more A LEVEL control range while maintaining the one-megohm \times 20 pF input RC characteristics.

Trigger Coupling

The A COUPLING switch offers a means of accepting or rejecting certain frequency components of the trigger signal. In the AC and LF REJ positions, the DC component of the trigger signal is blocked by coupling capacitors C435 or C436. In the AC position, frequency components below about 30 hertz are attenuated. In the LF REJ position, frequency components below about 30 kilohertz are attenuated.

The HF REJ position attenuates high-frequency components of the triggering signal. The trigger signal is AC coupled to the input, attenuating signals below about 30 hertz and above about 50 kilohertz. The DC position provides equal coupling for all signals from DC to 50 megahertz.

Input Stage

The trigger signal from the A COUPLING switch is connected to the Input Stage through the network C440-R438-R439-R440-R441. R438-R439 provide the input resistance for this stage. The voltage-divider action of R438-R439 allows about 98% of DC or low frequency signals applied to R438 to be available at the junction of R438 and R439. C440 along with the stray capacitance in the circuit forms an AC divider which maintains about this same voltage division for high-frequency signals. R440 limits the current drive to the gate of FET Q443. Diode D441 protects the circuit by clamping the gate of Q443 at about -12.5 volts if a high-amplitude negative signal is applied to the EXT TRIG INPUT connector. Over-voltage protection for high-amplitude positive signals is provided by the forward conduction of FET Q443.

Q443 is connected as a source follower to provide a high input impedance and a low output impedance. As a result, this stage provides isolation between the A Trigger Generator circuit and the trigger signal source. The output signal from Q443 is connected to the Slope Comparator stage through emitter follower Q453. Diodes D449 and D459 provide protection for the Slope Comparator stage transistors, Q454 and Q464.

Slope Comparator

Q454 and Q464 are connected as a difference amplifier (comparator)⁵ to provide selection of the slope and level at which the sweep is triggered. The reference voltage for the comparator is provided by the A LEVEL control, R460, and the A Trigger Level Center adjustment, R462. The A Trigger Level Center adjustment sets the level at the base of Q464 so the display is triggered at the zero-volt DC level of the incoming trigger signal when the A LEVEL control is centered. The A LEVEL control varies the base level of Q464 to select the point on the trigger signal where triggering occurs.

R458 establishes the emitter current of Q454 and Q464. The transistor with the most positive base controls conduction of the comparator. For example, assume that the trigger signal from the Input Stage is positive going and Q454 is forward biased. The increased current flow through R458 produces a larger voltage drop and the emitters of both Q454 and Q464 go more positive. A more positive voltage at the emitter of Q464 reverse biases this transistor, since its base is held at the voltage set by the A LEVEL control, and its collector current decreases. At the same time, Q454 is forward biased and its collector current increases. Notice that the signal currents at the collectors of Q454 and Q464 are opposite in phase. The sweep can be triggered from either the negative-going or positive-going slope of the input trigger signal by producing the trigger pulse from either the signal at the collector of Q464 for $-$ slope operation or the signal at the collector of Q454 for $+$ slope operation. This selection is made by the SLOPE switch, SW455.

When the A LEVEL control is set to 0 (midrange), the base of Q464 is at about one volt positive which corresponds to a zero-volt level at the input to this circuit (with correct calibration). The base-emitter drop of Q464 sets the common emitter level of Q454-Q464 to about $+0.3$ volts. Since the

base of Q454 must be about 0.65 volts more positive than the emitter before it can conduct, the comparator switches around the zero-volt level of the trigger signal (zero-volt level on the trigger signal corresponds to about one volt positive at this point). As the A LEVEL control is turned clockwise toward $+$, the voltage at the base of Q464 becomes more positive. This increases the current flow through R458 to produce a more positive voltage on the emitters of both Q454 and Q464. Now the trigger signal must rise more positive before Q454 is biased on. The resultant CRT display starts at a more positive point on the displayed signal. When the A LEVEL control is in the $-$ region, the effect is the opposite to produce a resultant CRT display which starts at a more negative point on the trigger signal.

The slope of the input signal which triggers the A sweep is determined by the A SLOPE switch, SW455. When the A SLOPE switch is set to the $-$ position, the collector of Q454 is connected to the $+12$ -volt supply through D456 and R467. The anode of D466 is grounded and it is reverse biased. Now the collector current of Q464 must flow through D465, R459, the parallel combination D475 and R468-R469-L469 and R467 to the $+12$ -volt supply (see Fig. 3-9). Since the output pulse from the A Trigger Generator circuit is derived from the negative-going portion of the signal applied to the Trigger TD stage, the sweep is triggered on the negative-going portion of the input trigger signal (signal applied to Trigger TD stage is in phase with the input signal for $-$ slope triggering). When the A SLOPE switch is set to $+$, conditions are reversed (see Fig. 3-10). Q464 is connected to the $+12$ -volt supply through D466 and R467. The anode of D456 is grounded to divert the collector current of Q454 through the Trigger TD stage. The signal applied to the Trigger TD stage is now 180° out of phase with the input trigger signal so the sweep is triggered on the positive-going portion of the input signal.

Trigger TD

The Trigger TD stage shapes the output of the Slope Comparator to provide a trigger pulse with a fast leading edge. Tunnel diode D475⁶ is quiescently biased so it operates in its low-voltage state. The current from one of the transistors in the Slope Comparator stage is diverted through the Trigger TD stage by the A SLOPE switch. As this current increases due to a change in the trigger signal, tunnel diode D475 switches to its high-voltage state. L469 opposes the sudden change in current which allows more current to pass through D475 and switch it more quickly. As the current flow stabilizes, L469 again conducts the major part of the current. However, the current through D475 remains high enough to hold it in its high-voltage state. The circuit remains in this condition until the current from the Slope Comparator stage decreases due to a change in the trigger signal applied to the input. Then, the current through D475 decreases and it reverts to its low-voltage state.

Pulse Amplifier

The trigger signal from the Trigger TD stage is connected to the base of the Pulse Amplifier, Q473, through R472. The trigger pulse at this point is basically a negative-going pulse with a fast rise. The width of the pulse depends upon the

⁵Phillip Cutler, "Semiconductor Circuit Analysis", McGraw-Hill, New York, pp. 365-372.

⁶Millman and Taub, pp. 452-455.

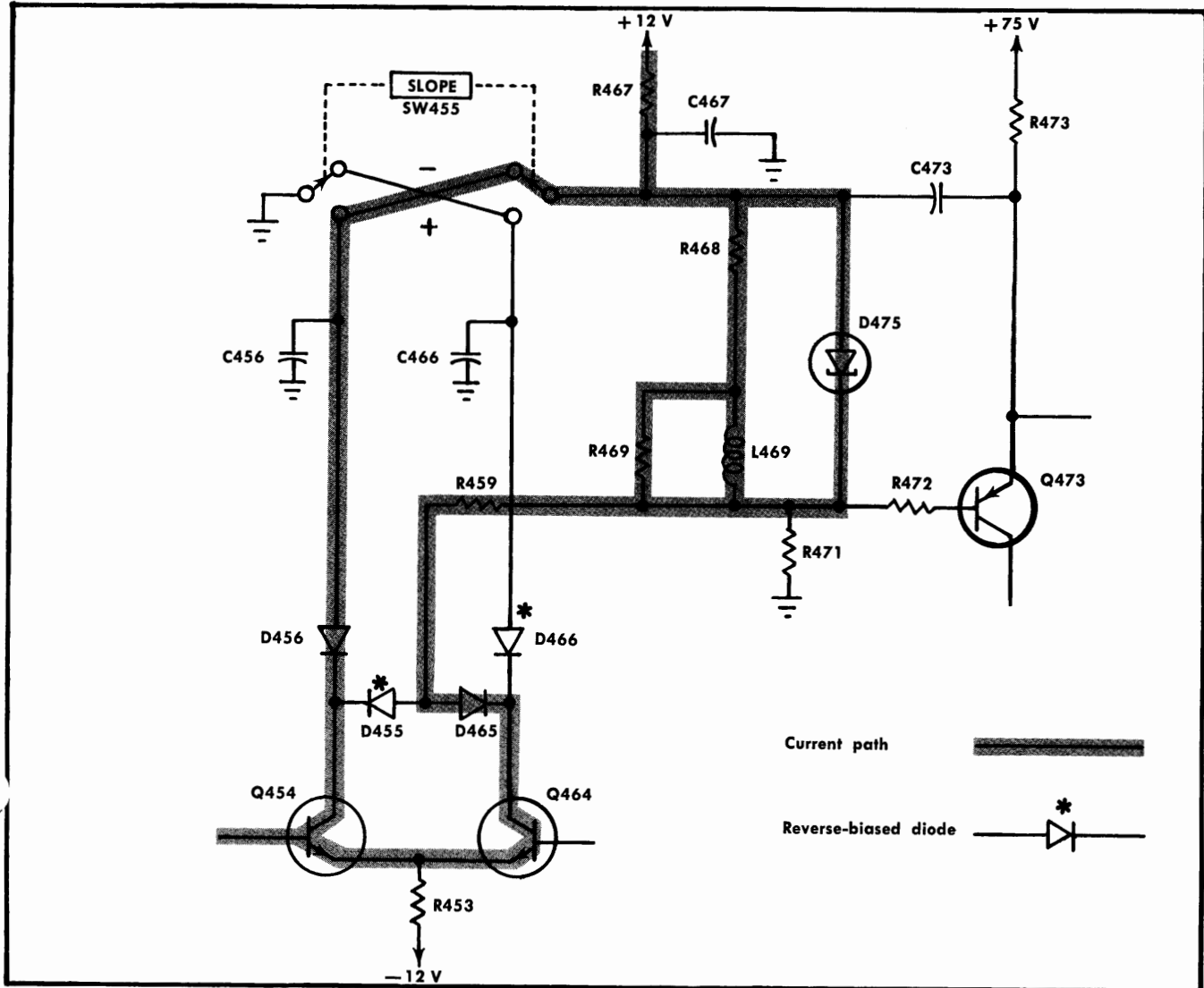

Fig. 3-9. Trigger path for negative-slope triggering (simplified A Trigger Generator diagram).

waveshape of the input signal and the setting of the A LEVEL control. Q473 is connected as an amplifier with the primary of pulse transformer T474 providing the major collector load. The negative-going pulse at the base of Q473 drives it into heavy conduction and the resulting current increase of Q473 flows through T474, R474, Q473, C473 and C467. Due to the short time constant of the RC network involving C473, the current of Q473 quickly returns to the level determined by R473. The resultant signal at the collector of Q473 is a positive-going fast-rise pulse with the width determined by the time constants of the RC network in the circuit. T474 inverts the output pulse to produce a negative-going trigger pulse which is coincident with the rise of the output signal from the Trigger TD stage. This negative-going trigger pulse is connected to the A Sweep Generator circuit through C476-R476. D474 limits the collector of Q473 from going more positive than about +0.5 volts. A simultaneous negative-going pulse with the same width as the trigger pulse is available at the emitter of Q473. This pulse is connected to the Auto Pulse Amplifier stage.

Auto Pulse Amplifier

The negative-going trigger pulse from the emitter of Q473 is connected to the base of Q484 through R481. This stage is similar to the Pulse Amplifier stage. Inductor L484 provides the collector load for this stage. The positive-going portion of the trigger pulse is coupled to the Auto Multivibrator stage through D484. D483 clamps the collector of Q484 at about -0.5 volts to eliminate negative transients.

Auto Multivibrator

The basic configuration of the Auto Multivibrator stage is a monostable multivibrator⁷ made up of Q485 and Q495. This stage produces the control gate for the auto trigger circuits located in the A Sweep Generator circuit. Under quiescent conditions (no trigger signal), the base of Q495 is

⁷Ibid., pp. 405-438.

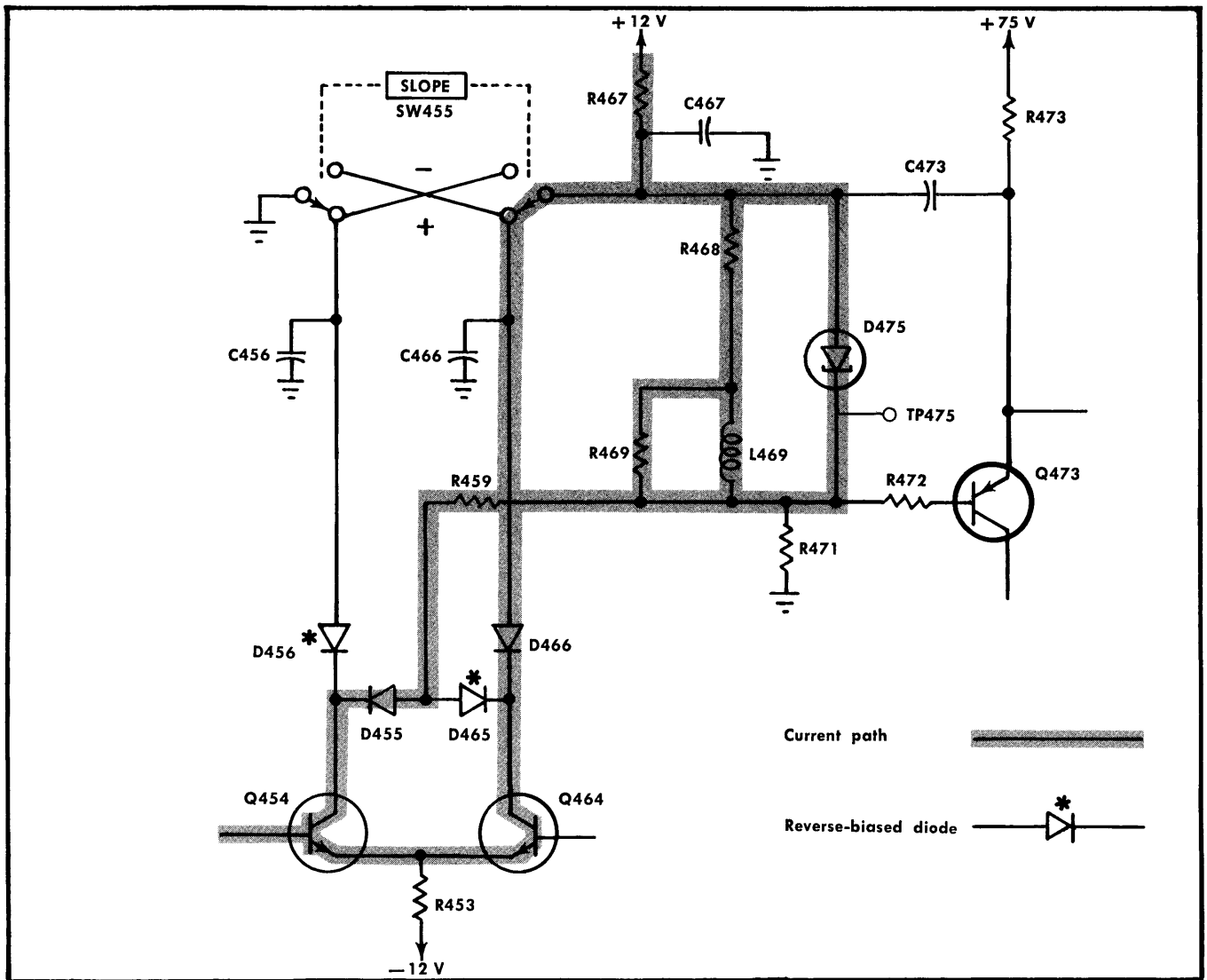

Fig. 3-10. Trigger path for positive-slope triggering (simplified A Trigger Generator diagram).

near zero volts. The base of Q485 is held at about -0.65 volts by the forward voltage drop of D484. Since the base of Q495 is the most positive, it conducts and raises the emitter level of Q485 positive enough to hold it off. C485 charges to about $+13$ volts where it is clamped by D486 and D493. The base of Q494 is clamped at about $+12.6$ volts by D493 which reverse biases it. Since there is no current flow through Q494, its collector level goes negative.

When a trigger signal is present, the positive-going pulses from the Auto Pulse Amplifier stage turn Q485 on through D484. The collector of Q485 goes negative and C485 discharges rapidly through Q485, R490 and R485. As C485 discharges, the current flow through R490 biases Q495 off. When C485 is fully discharged, the current flow through R490 ceases and Q495 comes back on to reset the multivibrator. Now C485 begins to charge towards $+75$ volts through R486. Current also flows through R494 and the base of Q494 goes negative to bias it on. The collector level of Q494 rises positive to produce the auto gate output for the A Sweep Generator circuit.

For low-frequency signals (below about 30 hertz), C485 recharges to about $+13$ volts in about 85 milliseconds. Then Q494 is biased off to end the auto gate (display free runs or is unstable). However, if a repetitive trigger signal turns Q485 on again before C485 has charged to $+13$ volts, C485 is discharged completely again and once more starts to charge towards $+75$ volts. Since the base of Q494 remains negative enough with a repetitive trigger signal to hold it in conduction, the auto output level is continuous for a stable display (with correct A LEVEL control setting).

A SWEEP GENERATOR

General

The A Sweep Generator circuit produces a sawtooth voltage which is amplified by the Horizontal Amplifier circuit to provide horizontal sweep deflection on the CRT. This output signal is generated on command (trigger pulse) from the A Sweep Generator circuit. The A Sweep Generator cir-

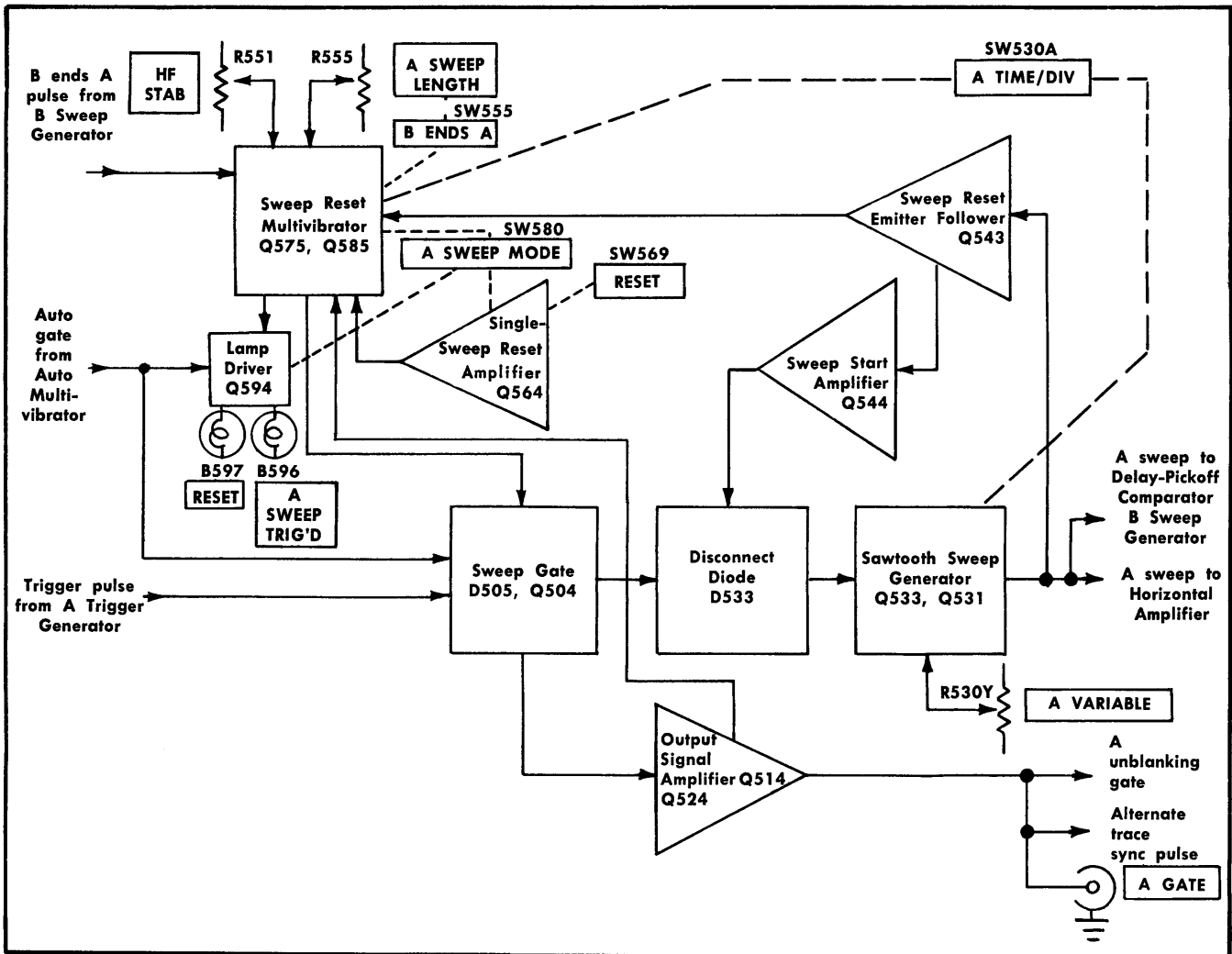

Fig. 3-11. A Sweep Generator detailed block diagram.

circuit also produces an unblanking gate to unblank the CRT during A sweep time. In addition this circuit produces several control signals for other circuits within this instrument and several output signals to the side-panel connectors. Fig. 3-11 shows a detailed block diagram of the A Sweep Generator circuit. A schematic of this circuit is shown on diagram 9 at the rear of this manual.

The A SWEEP MODE switch allows three modes of operation. In the NORM TRIG position, a sweep is produced only when a trigger pulse is received from the A Trigger Generator circuit. Operation in the AUTO TRIG position is much the same as NORM TRIG except that a free-running trace is displayed when a trigger pulse is not present. In the SINGLE SWEEP position, operation is also similar to NORM TRIG except that the sweep is not recurrent. The following circuit description is given with the A SWEEP MODE switch set to NORM TRIG. Differences in operation for the other two modes are then discussed later.

Normal Trigger Mode Operation

Sweep Gate. The negative-going trigger pulse generated by the A Trigger Generator circuit is applied to the Sweep

Gate stage through D501. Tunnel diode D505 is quiescently biased on in its low-voltage state. When the negative-going trigger pulse is applied to its cathode, the current through D505 increases and it rapidly switches to its high-voltage state where it remains until reset by the Sweep Reset Multivibrator stage at the end of the sweep. The negative-going level at the cathode of D505 is connected to the base of Q504 through C503 and R503. Q504 is turned on and its collector goes positive. This positive-going step is connected to the Disconnect Diode through C509-R509 and to the Output Signal Amplifier through C506-R506.

Output Signal Amplifier. The positive-going gate pulse from the Sweep Gate stage applied to the base of Q514 produces a negative-going pulse at its collector. This pulse is connected to the Z Axis Amplifier circuit through R519 to unblank the CRT during sweep time. It is also connected to the Holdoff Capacitor through R517 and D517 to discharge it completely at the beginning of each sweep.

The positive-going gate pulse at the base of Q514 is also coupled from the emitter of Q514 to the emitter of Q524. The resulting positive-going signal at the collector of Q524 is coupled to the Vertical Switching circuit through C526 to

Circuit Description—Type 453/R453

provide an alternate-trace sync pulse for dual-trace operation. It is also coupled to the A GATE output connector on the side panel through R529. D528 and D529 clamp the gate signal so it does not go more than about 0.5 volts negative and 12.5 volts positive.

Disconnect Diode. The Disconnect Diode, D533, is quiescently conducting current through R506, R508, R509, R530 and R531. The positive-going gate signal from Q504 reverse biases D533 and interrupts the quiescent current flow. Now the timing current through the Timing Resistor begins to charge the Timing Capacitor, C530, so the Sawtooth Sweep Generator stage can produce a sawtooth output signal. The positive-going gate signal also reverse biases D547 to disconnect the Sweep Start Amplifier. The Disconnect Diode is a fast turn-off diode with low reverse leakage to reduce switching time and improve timing linearity at the start of the sweep.

Sawtooth Sweep Generator. The basic generator circuit is a Miller Integrator circuit.⁸ When the current flow through D533 is interrupted by the Sweep Gate signal, the Timing Capacitor, C530, begins to charge through the Timing Resistor, R530, and the A Sweep Cal Adjustment, R531. The Timing Capacitor and Resistor are selected by the A TIME/DIV switch to change sweep rate. The A Sweep Cal adjustment allows calibration for accurate sweep timing. The A VARIABLE control, R530Y (see Timing Switch diagram), provides variable sweep rates by changing the charge time of C530.

The positive-going voltage at the R530 side of C530 as it charges toward +75 volts is connected to the gate of FET Q533. This produces a positive-going output voltage which is connected to the base of Q531 through R536. Q531 amplifies and inverts the voltage change at its base to produce a negative-going sawtooth output. To provide a linear charging rate for the Timing Capacitor, the sweep output signal is connected to the negative side of C530. This feedback provides a constant charging current for C530 which maintains a constant charge rate to produce a linear sawtooth output signal. The output voltage continues to go negative until the circuit is reset through the Sweep Reset Multivibrator stage. The output signal from the collector of Q531 is connected to the Horizontal Amplifier circuit through R538 and the Delay Pickoff Comparator stage in the B Sweep Generator circuit through R532.

Sweep Reset Emitter Follower. The negative-going sawtooth voltage at the collector of Q531 is connected to the base of the Sweep Reset Emitter Follower stage, Q543. The negative-going signal at the emitter of Q543 is coupled to the Sweep Reset Multivibrator stage to determine sweep length and to the Sweep Start Amplifier stage to set the starting point for the sweep. D542 connected to the base of Q543 protects this stage during instrument warmup.

Sweep Start Amplifier. The signal at the emitter of Q543 goes negative along with the applied sawtooth signal. This increases the forward bias on D543 which in turn decreases the forward bias on D545 as the sawtooth goes negative. When the anode of D543 reaches a level about one volt more negative than the level on the base of Q544, it is reverse biased to interrupt the current flow through Q544.

The circuit remains in this condition until after the sweep retrace is complete. As the voltage at the emitter of Q543 returns to its original DC level at the end of the sweep, D545 is again forward biased and Q544 conducts through D547 to set the quiescent current through the Disconnect Diode, D533. This establishes the correct starting point for the sweep. D546 clamps the collector of Q544 at about +0.5 volt. This reduces the voltage swing at the collector of Q544 and improves the response time. The Sweep Start adjustment, R758 (in the B Sweep Generator circuit), sets the base voltage level of Q544. The collector of Q531 is held at this same voltage level through the feedback loop comprised of Q533 and Q531, thereby setting the starting point of the sawtooth output signal. The level established by the Sweep Start adjustment is also connected to the B Sweep Start Amplifier so the B sweep starts at the same voltage level as the A sweep.

Sweep Reset Multivibrator. The negative-going sawtooth signal at the emitter of Q543 is coupled to the cathodes of D555 and D556. These diodes are quiescently reverse biased at the start of the sweep. As the sawtooth voltage at the cathode of D555 goes negative, D555 is forward biased at a level about 0.5 volts more negative than the base level of Q575 (A SWEEP LENGTH control in FULL position). Then the negative-going sawtooth signal from the Sweep Reset Emitter Follower stage is connected to the base of Q575. Q575 and Q585 are connected as a Schmitt bistable multivibrator⁹. Quiescently, at the start of the sweep, Q585 is conducting and Q575 is biased off to produce a negative level at its collector. This negative level allows the Sweep Gate tunnel diode, D505, to be switched to produce a sweep as discussed previously. When the negative-going sweep signal is connected to the base of Q575 through D555, Q575 is eventually biased on and Q585 is biased off by the emitter coupling between Q575 and Q585. The collector of Q575 rises positive and D505 is switched back to its low-voltage state through R502. D505 is held in its low-voltage state so it cannot accept incoming trigger pulses until after the Sweep Reset Multivibrator stage is reset. This ends the Sweep Gate stage output and the Disconnect Amplifier stage is turned on to rapidly discharge the Timing Capacitor and pull the gate of Q533 rapidly negative to its original level to produce the retrace portion of the sawtooth signal. The Sawtooth Sweep Generator stage is now ready to produce another sweep as soon as the Sweep Reset Multivibrator stage is reset and another trigger pulse is received.

When Q575 is turned on to end the sweep, it remains in conduction for a period of time to establish a holdoff period and allow all circuits to return to their original conditions before the next sweep is produced. The holdoff time is determined by the charge rate of the Holdoff Capacitor, C550. At the start of the sweep, C550 is completely discharged by the unblanking gate at the collector of Q514. It is held at this level throughout the sweep time. When the Sweep Gate output ends, Q514 is cut off and C550 begins to charge toward +75 volts through R552 and R551. The positive-going voltage across the Holdoff Capacitor as it charges is connected to the base of Q575 through D552 and D559. When the base of Q575 rises positive enough so it is reverse biased, its collector level drops negative and Q585 comes back into conduction. The bias on the Sweep Gate tunnel diode, D505, returns to a level that allows it to accept the next trigger pulse (D505 is enabled). The Holdoff Capacitor, C550, is

⁸Ibid., pp. 540-548.

⁹Ibid., pp. 389-394.

changed by the A TIME/DIV switch for the various sweep rates to provide the correct holdoff time. Diagram 12 shows a complete diagram of the A TIME/DIV switch.

As the A SWEEP LENGTH control is rotated counterclockwise from the FULL position, R555 places a more positive level on the anode of D556 than is on the anode of D555 so D555 remains reverse biased. The Sweep Reset Multivibrator is reset as described for FULL sweep length operation at the point where D556 (instead of D555) is forward biased. Since this occurs at a more positive level on the negative-going sawtooth, the displayed sweep is shorter. Thus, R555 provides a variable sweep length for the A Sweep (from about 11 divisions in the FULL position to about four divisions in the fully clockwise position—not in B ENDS A detent). In the B ENDS A position (fully counterclockwise), a negative-going pulse from the B Sweep Generator circuit is connected to the base of Q575 through D575 at the end of the B sweep time. If the A sweep is still running, this negative-going pulse turns Q575 on to end the A sweep also. Since the A sweep ends immediately following the end of the B sweep, this position provides the maximum repetition rate (brightest trace) for Delayed Sweep mode operation.

The HF STAB control, R551, varies the charging rate of the Holdoff Capacitor to provide a stable display at fast sweep rates. This change in holdoff allows sweep synchronization for less display jitter at the faster sweep rates. The HF STAB control has little effect at slow sweep rates.

Lamp Driver. The auto gate level from the Auto Multivibrator stage in the A Trigger Generator circuit is connected to the Lamp Driver stage, Q594, through D591 and D594. This gate level is coincident with the trigger pulse generated by the A Trigger Generator circuit and is present only when the instrument is correctly triggered. The positive-going auto-gate level saturates Q594 and its collector goes negative to about zero volts. This applies about 12 volts across B596, A SWEEP TRIG'D light, and it comes on. This light remains on as long as the auto-gate level is present. When the auto-gate level goes negative because the instrument is no longer triggered, D595 clamps the base level of Q594 at about -0.5 volt and Q594 is reverse biased. The collector of Q594 rises positive and B596 goes off.

Auto Trigger Mode Operation

Operation of the A Sweep Generator circuit in the AUTO TRIG position of the A SWEEP MODE switch, is the same as for the NORM TRIG position just described when a trigger pulse is applied. However, when a trigger pulse is not present, a free-running reference trace is produced in the AUTO TRIG mode. This occurs as follows:

The auto-gate level from the Auto Multivibrator stage in the A Trigger Generator circuit is also connected to D592. When the auto-gate level is positive (triggered), the current flowing through D592 and R593 reverse biases D593 and the Sweep Gate tunnel diode, D505, operates as previously described for NORM TRIG operation. However, when the instrument is not triggered, the auto-gate level drops negative and the reduction in current through D592 and R593 allows D593 to become forward biased. Now, when the Sweep Reset Multivibrator stage resets at the end of the holdoff period, the additional current from R593-D593 flows through D505 and is sufficient to automatically switch

the Sweep Gate tunnel diode back into its high-voltage state. The result is that the A Sweep Generator circuit is automatically retriggered at the end of each holdoff period and a free-running sweep is produced. Since the sweep free runs at the sweep rate of the A Sweep Generator circuit (as selected by the A TIME/DIV switch), a bright reference trace is produced even at fast sweep rates.

Single Sweep Operation

General. Operation of the Sweep Generator in the SINGLE SWEEP position of the A SWEEP MODE switch is similar to operation in the other modes. However, after one sweep has been produced, the Sweep Reset Multivibrator stage does not reset. All succeeding trigger pulses are locked out until the RESET button is pressed.

In the SINGLE SWEEP position, the A SWEEP MODE switch disconnects the charging current for the Holdoff Capacitor. Now, Q575 remains on when it is forward biased through D555 or D556 at the end of the sweep. With Q575 on, D505 is held in its low-voltage state to lock out any incoming trigger pulses. The circuit remains in this condition until reset by the Single-Sweep Reset Amplifier stage.

Single-Sweep Reset Amplifier. The Single-Sweep Reset Amplifier, Q564, produces a pulse to reset the Sweep Reset Multivibrator stage so another sweep can be produced in the SINGLE SWEEP mode of operation. Quiescently, Q564 is biased off and the RESET switch is open. When the RESET button is pressed, B568 ignites and the voltage at the base of Q564 goes negative. Q564 saturates and produces a positive-going output pulse. This pulse has sufficient amplitude to shut off Q575 and allow Q585 to conduct and enable the Sweep Gate tunnel diode, D505. Now the A Sweep Generator circuit can be triggered when the next trigger pulse is received.

Lamp Driver. In the SINGLE SWEEP mode, the cathode of D591 is connected to ground to block the incoming auto-gate level. The A SWEEP TRIG'D light, B596 is disconnected from the collector of Q594 and the RESET light, B597, is connected into the circuit. The anode of D595 is also disconnected from ground. Now the condition of Q594 is determined by the Sweep Reset Multivibrator stage. When Q585 is off before the RESET button is pressed, the collector level of Q585 is negative. The current through R594-D595-R587-R588 sets the base level of Q594 negative enough to bias it off. However, when the RESET button is pressed and Q585 turns on, its collector goes positive. This positive level allows the base of Q594 to go positive also and it is biased on. The collector of Q594 goes negative and the RESET light comes on. Q594 and the RESET light remain on until Q585 turns off again at the end of the next sweep.

B TRIGGER GENERATOR

General

The B Trigger Generator circuit is basically the same as the A Trigger Generator circuit. Only the differences between the two circuits are discussed here. Portions of the circuit not described in the following discussion operate in the same manner as for the A Trigger Generator circuit

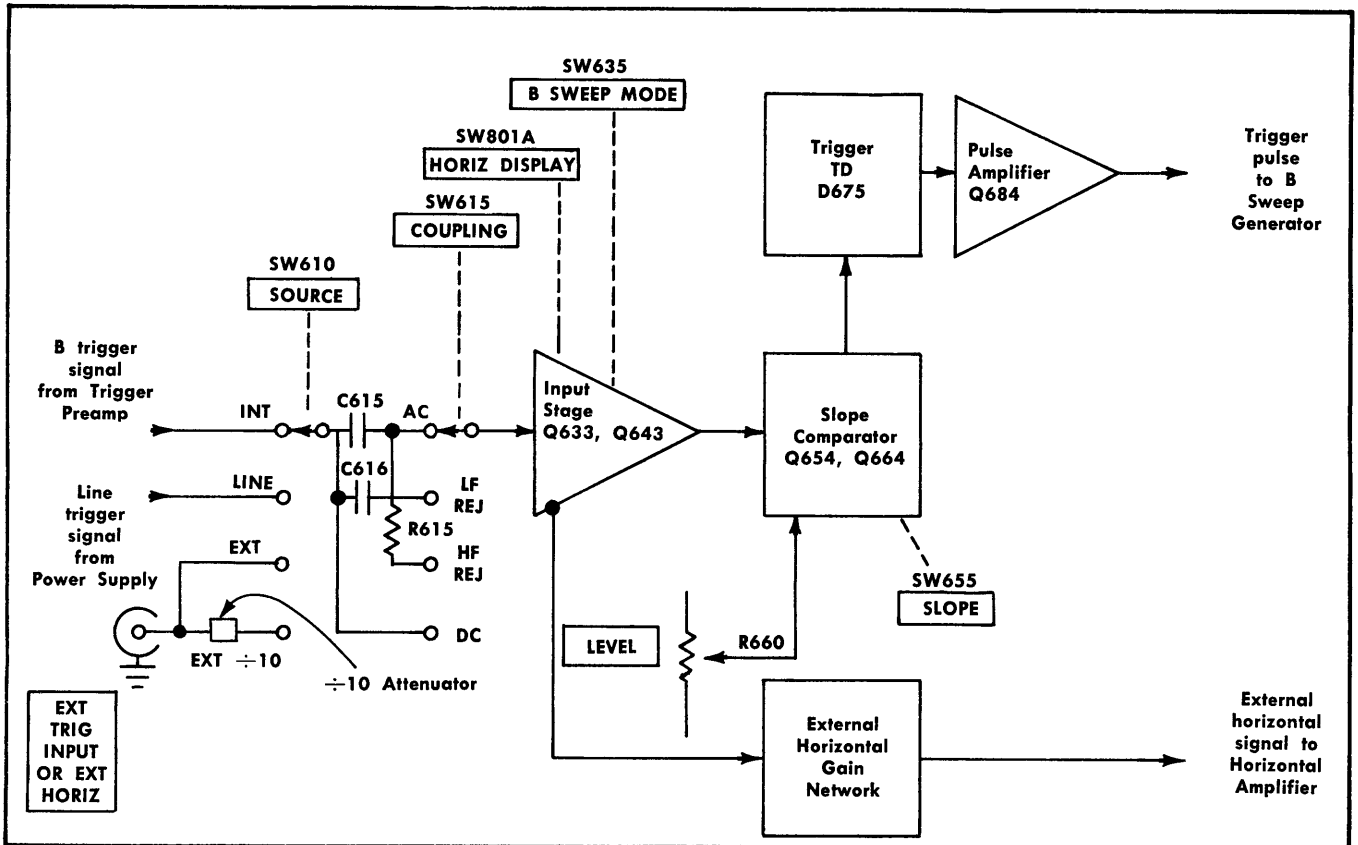

Fig. 3-12. B Trigger Generator detailed block diagram.

(corresponding circuit numbers are assigned in the 600-699 range). Fig. 3-12 shows a detailed block diagram of the B Trigger Generator circuit. A schematic of this circuit is shown on diagram 10 at the rear of this manual.

Input Stage

The B Input Stage operates in basically the same manner as described for the A Trigger Generator circuit. However, in the B Trigger Generator circuit, the HORIZ DISPLAY switch, SW801A and D638, block the B Trigger Generator input signal in the modes where B triggering is not desired. In the A position of the HORIZ DISPLAY switch, -12 volts is connected to the cathode of D635 and it is forward biased. Since the cathode of D638 is connected to +12 volts through R638, D638 is reverse biased and it blocks the trigger signal. In the A INTEN DURING B and DELAYED SWEEP (B) positions, a second switch, B SWEEP MODE SW635 determines whether the B trigger signal is blocked or passed to the Slope Comparator stage. If the B SWEEP MODE switch is in the B STARTS AFTER DELAY TIME position, the trigger signal is blocked as in the A position. However, the B Sweep Generator essentially free runs in this position as controlled by another portion of the B SWEEP MODE switch located in the B Sweep Generator circuit (see B Sweep Generator discussion). In the TRIGGERABLE AFTER DELAY TIME position, -12 volts is connected to the cathode of D638 through R639 rather than to D635. This forward biases D638 and allows the B trigger signal to pass to the B Slope Comparator stage.

In all positions of the HORIZ DISPLAY switch except EXT HORIZ, D641 is back biased since it is connected to +12 volts through R641. In the EXT HORIZ position, D638 is reverse biased because its cathode rises positive toward +12 volts applied through R638. Therefore, the trigger signal can not pass through D638. D641 is forward biased by -12 volts connected to its cathode through R642 by SW801A. The signal from the Input Stage is connected to the Horizontal Amplifier through D641 and the External Horizontal Gain Network, R644-R645-R646. Gain of the External Horizontal circuit is set by R645, Ext Horiz Gain, so a signal applied to the Channel 1 INPUT connector produces the indicated horizontal deflection.

The external horizontal signal can be obtained either externally from the B EXT TRIG INPUT or EXT HORIZ connector when the B SOURCE switch is set to EXT or EXT ÷ 10, or internally from Channel 1 when the TRIGGER switch is in the CH 1 ONLY position and the B SOURCE switch is set to INT.

Pulse Amplifier

The Pulse Amplifier in the B Trigger Generator operates much the same as in the A Trigger Generator. However, since there is no Auto circuit in the B Trigger Generator, a pulse is available only at the collector of Q684. The output pulse is applied to the B Sweep Generator through T686 and R688-C688.

B SWEEP GENERATOR

General

The B Sweep Generator circuit is basically the same as the A Sweep Generator circuit. Only the differences between the two circuits are discussed here. The following circuits operate as described for the A Sweep Generator (corresponding circuit numbers assigned in the 700-799 range): Sweep Gate (D705, Q704), Disconnect Diode (D742), Sawtooth Sweep Generator (Q743 and Q741), Sweep Reset Emitter Follower (Q753) and the Sweep Start Amplifier (Q754). Fig. 3-13 shows a detailed block diagram of the B Sweep Generator circuit. A schematic of this circuit is shown on diagram 11 at the rear of this manual.

Output Signal Amplifier

Basically, the B Output Signal Amplifier is the same as the corresponding circuit in the A Sweep Generator circuit. Two unblanking gates are available from the collector of Q714. An unblanking gate is connected to the Z Axis Amp-

lifier circuit through R717 and the HORIZ DISPLAY switch to unblank the CRT to display the B sweep. For A INTEN DURING B operation, additional unblanking current is added to the A unblanking gate during the B sweep time. This produces a display which is partially unblanked during A sweep time and further unblanked during B sweep time to produce a display which has an intensified portion coincident with the B sweep time.

Delay-Pickoff Comparator

The Delay-Pickoff Comparator stage allows selection of the amount of delay from the start of the A sweep before the B Sweep Generator is turned on. This stage allows the start of B sweep to be delayed between 0.20 and 10.20 times the setting of the A TIME/DIV switch. Then, the B Sweep Generator is turned on and operates at a sweep rate independent of the A Sweep Generator (determined by setting of B TIME/DIV switch).

Q764A and B are connected as a voltage comparator. In this configuration, the transistor with the most positive

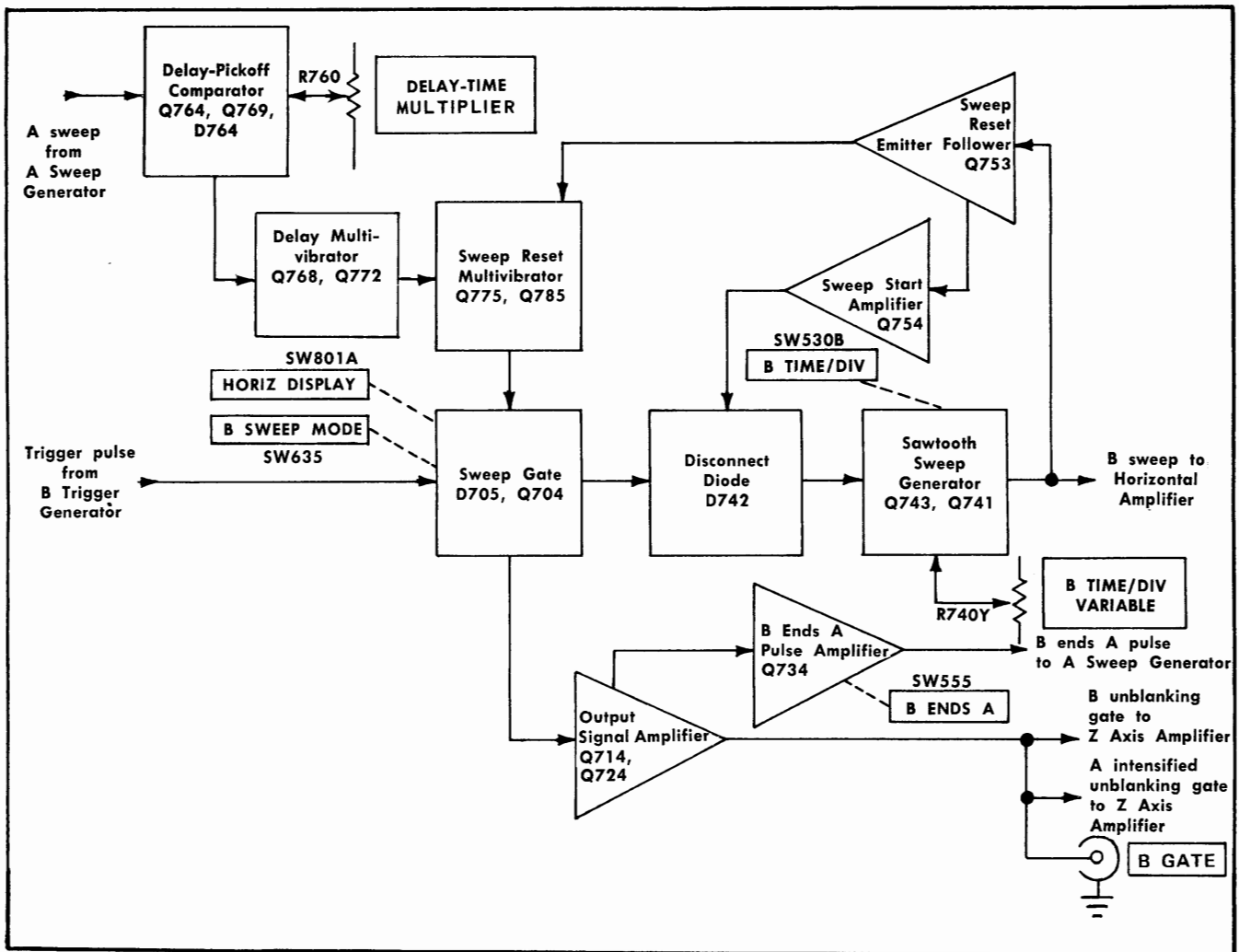

Fig. 3-13. B Sweep Generator detailed block diagram.

Circuit Description—Type 453/R453

base controls conduction. A dual transistor, Q764, and a dual diode, D764, provide temperature stability for the comparator circuit. Q769 maintains a constant current through the conducting transistor. Reference voltage for the comparator circuit is provided by the DELAY-TIME MULTIPLIER control, R760. The voltage to this control is filtered by R759-C759 to hold it constant and allow precise delay pickoff. The instrument is calibrated so that the major dial markings of R760 correspond to the major divisions of horizontal deflection on the graticule. For example, if the DELAY-TIME MULTIPLIER dial is set to 5.00, the B Sweep Generator is delayed five divisions of the A sweep time before it can produce a sweep (B sweep delay time equals five times setting of A TIME/DIV switch).

The output sawtooth from the A Sawtooth Sweep Generator stage is connected to the base of Q764A. The quiescent level of the A sawtooth biases Q764A on and its collector is negative enough to hold Q772 in the Delay Multivibrator stage in conduction. As the A sweep output sawtooth begins to run down, the base of Q764A also goes negative. When it goes more negative than the level at the base of Q764B (established by the DELAY-TIME MULTIPLIER control), Q764B takes over conduction of the comparator and Q764A shuts off. This also switches the Delay Multivibrator stage to produce a negative-going reset pulse to the B Sweep Reset Multivibrator.

When the A sweep resets, Q764A is again returned to conduction and Q764B is turned off. This also resets the Delay Multivibrator to produce a positive-going output pulse. If the B sweep is still running, this positive-going pulse forces the B Sweep Reset Multivibrator to reset and end the B sweep also.

Delay Multivibrator

The Delay Multivibrator, Q768 and Q772, provides a lockout for the B Sweep Generator circuit during the A Sweep Generator reset and holdoff time to allow accurate delayed-sweep measurements when the DELAY-TIME MULTIPLIER dial is set near 0. This stage prevents the B Sweep Generator from being triggered before the A Sweep Generator is triggered (B Sweep Generator must always be triggered after the A Sweep Generator is triggered). This circuit also produces a pulse which resets the B Sweep Reset Multivibrator stage after the delay period so the B Sweep Gate tunnel diode can be enabled to produce a sweep.

Transistors Q768 and Q772 are connected as a Schmitt bistable multivibrator. Quiescently, Q772 is held on by the negative level at the collector of Q764A and Q768 remains off. The circuit remains in this condition until the incoming A Sweep switches the Delay-Pickoff Comparator (see Delay-Pickoff Comparator discussion). Then, the base of Q772 goes positive and it turns off. At the same time, the base of Q768 is pulled negative by the collector level of Q764B and it turns on. The collector of Q772 goes negative and a negative-going output pulse is coupled to the B Sweep Reset Multivibrator stage through C774. This pulse resets the B Sweep Reset Multivibrator which in turn enables the B Sweep Gate stage.

Sweep Reset Multivibrator

The basic B Sweep Reset Multivibrator configuration and operation is the same as for the A Sweep Generator. How-

ever, several differences do exist. The B Sweep Reset Multivibrator does not have a sweep length network for variable sweep length or a Holdoff Capacitor and associated circuit to reset the B Sweep Reset Multivibrator after the retrace. Instead, the negative-going sweep from the B Sweep Reset Emitter Follower, Q753, is connected to the base of Q785 through D748. Diode D748 is forward biased when the sweep voltage at the emitter of Q753 drops about 0.5 volts more negative than the level at the base of Q785 established by voltage divider R784-R785 between +12 volts and the collector of Q775. This negative-going sawtooth turns on Q785 and its collector goes positive to switch the B Sweep Gate tunnel diode, D705 to its low-voltage state, which resets the B Sweep. Q785 remains on and holds the B Sweep Gate tunnel diode locked out until the B Sweep Reset Multivibrator is reset by the Delay Multivibrator.

When the B Sweep Reset Multivibrator is reset by the Delay Multivibrator, Q775 comes on and Q785 turns off. The collector of Q785 goes negative and the B Sweep Gate tunnel diode, D705, is enabled. The state in which D705 remains depends upon the B SWEEP MODE switch and the HORIZ DISPLAY switch. When the B SWEEP MODE switch, SW635, is set to the TRIGGERABLE AFTER DELAY TIME position, D705 is biased so it can be switched to its high-voltage state by the next trigger pulse from the B Trigger Generator. However, if the B SWEEP MODE switch is set to the B STARTS AFTER DELAY TIME position, the setting of the HORIZ DISPLAY switch, SW801A, determines operation of the B Sweep Gate tunnel diode. In the A position, the B trigger pulses are blocked in the B Trigger Generator circuit so the B Sweep Generator cannot be triggered and does not produce a sweep. In the A INTEN DURING B and DELAYED SWEEP (B) position, -12 volts is connected to the cathode of D705 through R786 and R789. This voltage pulls the cathode of D705 negative enough so that it automatically switches to its high-voltage state after it is enabled by the B Sweep Reset Multivibrator stage. This produces a free-running B sweep Reset similar to the no trigger AUTO TRIG mode in the A Sweep Generator. However, since the B Sweep is reset (and automatically retriggered) at a fixed point on the A sweep sawtooth, the display is relatively stable. The best delayed sweep stability is provided in the TRIGGERABLE AFTER DELAY TIME position, since the B sweep is triggered by the trigger signal in this mode.

B Ends A Pulse Amplifier

The positive-going voltage as the B unblanking gate ends is coupled to the B Ends A Pulse Amplifier, Q734, through C731 and D731. When the A SWEEP LENGTH control is in the B ENDS A position, this pulse saturates Q734 to produce a negative-going output pulse at its collector. This negative-going pulse is connected to the A Sweep Reset Multivibrator stage to reset the A sweep at the end of the B sweep for maximum delayed sweep repetition rate.

HORIZONTAL AMPLIFIER

General

The Horizontal Amplifier circuit provides the output signal to the CRT horizontal deflection plates. In all positions of the HORIZ DISPLAY switch except EXT HORIZ, the horizontal deflection signal is a sawtooth from either the A Sweep Generator circuit or the B Sweep Generator circuit.

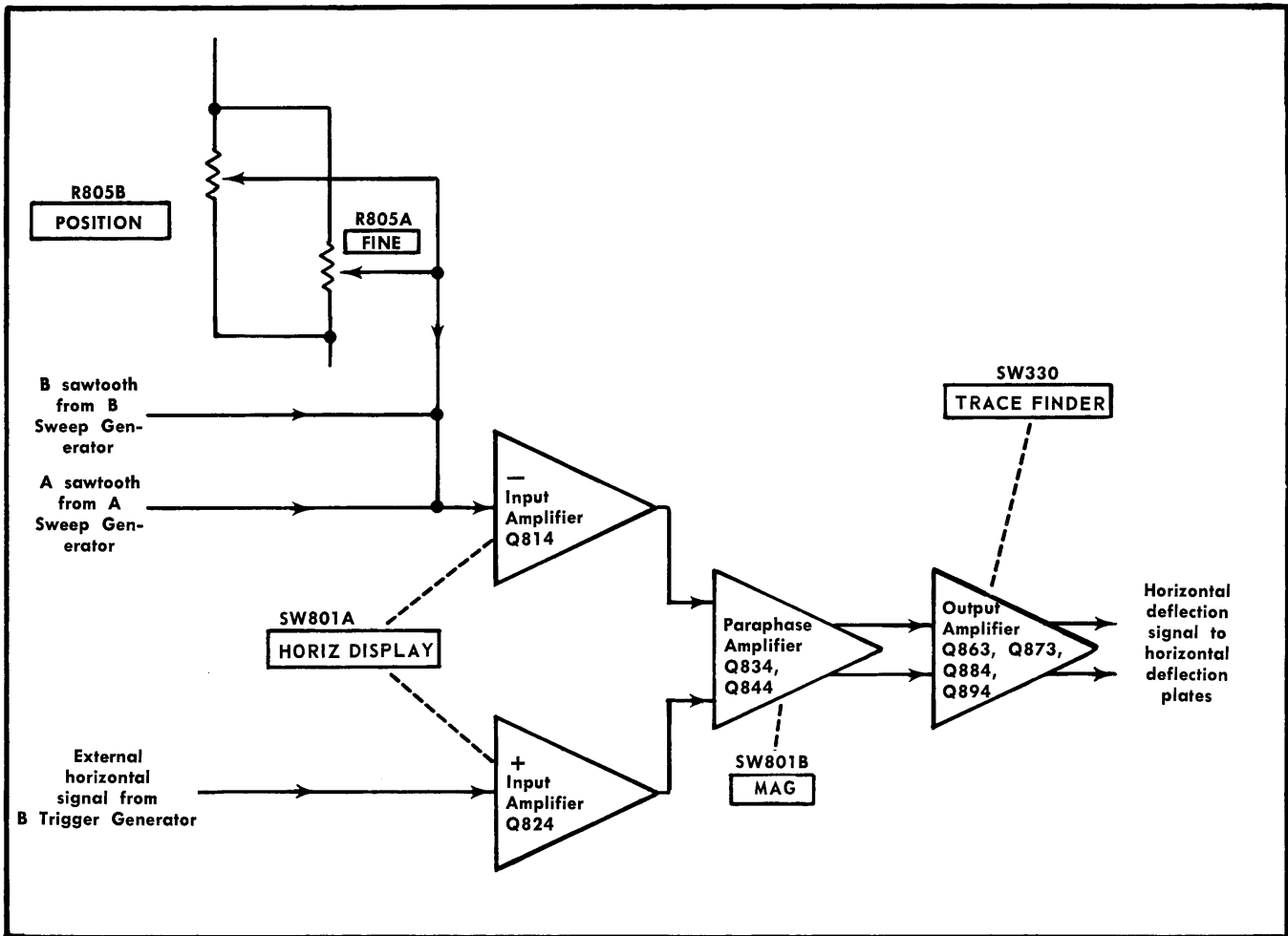

Fig. 3-14. Horizontal Amplifier detailed block diagram.

In the EXT HORIZ position, the horizontal deflection signal is obtained from the Input Stage of the B Trigger Generator. In addition, this circuit contains the horizontal magnifier circuit and the horizontal positioning network. Fig. 3-14 shows a detailed block diagram of the Horizontal Amplifier circuit. A schematic of this circuit is shown on diagram 13 at the rear of this manual.

Input Amplifiers

The input signal for the Horizontal Amplifier is selected by the HORIZ DISPLAY switch, SW801A. In the A and A INTEN DURING B positions of the HORIZ DISPLAY switch, the sawtooth from the A Sweep Generator is connected to the base of the — Input Amplifier, Q814, through R803. In the DELAYED SWEEP (B) position, the B sawtooth is connected to the base of Q814. Whichever sawtooth signal is connected to the base of Q814 produces a current change which is amplified to produce a positive-going sawtooth voltage at the collector. This positive-going sawtooth signal is connected to the base of Q834 in the Paraphase Amplifier stage.

In the EXT HORIZ position of the HORIZ DISPLAY switch, the external horizontal signal from the B Trigger Generator

circuit is connected to the base of the + Input Amplifier, Q824, through R821. The A and B sawtooth signals are grounded by the HORIZ DISPLAY switch. The B SOURCE switch selects either the internal signal from Channel 1 (TRIGGER switch set to CH 1 ONLY) or an external signal connected to the EXT HORIZ connector. When the internal signal is selected, the Channel 1 deflection factor as indicated by the CH 1 VOLTS/DIV switch applies as Horizontal Volts/Division. More information on the external horizontal circuitry is contained in the B Trigger Generator circuit discussion.

Horizontal positioning is provided by the POSITION control, R805A, and the FINE control, R805B, connected to the base of Q814. These controls vary the quiescent DC level at the base of Q814 which in turn sets the DC level at the horizontal deflection plates to determine the horizontal position of the trace. C804-R804 eliminate common-mode noise from the position controls.

Paraphase Amplifier

The output of the + and — Input Amplifier stages is connected to the Paraphase Amplifier stage, Q834 and Q844. This stage converts the single-ended input signal from either

Circuit Description—Type 453/R453

Input Amplifier stage to a push-pull output signal which is necessary to drive the horizontal deflection plates of the CRT. In all positions of the HORIZ DISPLAY switch except EXT HORIZ, a positive-going sawtooth signal is connected to the base of Q834 through Q814. This produces a negative-going sawtooth voltage at the collector of Q834. At the same time, the emitter of Q834 goes positive and this change is connected to the emitter of Q844 through the gain-setting network, R835-R836-R845-R846. In all positions of the HORIZ DISPLAY switch except EXT HORIZ, no signal is connected to the base of Q844 through Q824 so that Q844 operates as the emitter-driven section of a paraphase amplifier. Then, the positive-going change at its emitter is amplified to produce a positive-going sawtooth signal at the collector. Thus the single-ended input sawtooth signal has been amplified and is available as a push-pull signal at the collectors of Q834 and Q844.

In the EXT HORIZ position of the HORIZ DISPLAY switch, the external horizontal deflection signal is connected to the base of Q844 through Q824 and the sawtooth signal at the base of Q814 is disconnected. Now, the circuit operates much the same as just described with the sawtooth input. A positive-going external horizontal deflection signal produces a negative-going change at the base of Q844 which decreases the current flow through this transistor. The collector of Q844 goes positive while the emitter-coupled signal to Q834 produces a negative-going change at the collector of Q834.

This stage also provides adjustment to set the normal and magnified gain of the Horizontal Amplifier circuit, and the MAG switch to provide a horizontal sweep which is magnified 10 times. For normal sweep operation (MAG switch set to OFF), R835 and R836 control the emitter degeneration between Q834 and Q844 to set the gain of the stage. R835, Normal Gain, is adjusted to provide calibrated sweep rates. When the MAG switch, SW801B, is set to the $\times 10$ position, R845 and R846 are connected in parallel with R835 and R836. This additional resistance decreases the emitter degeneration of this stage and increases the gain of the circuit 10 times. R845, Mag Gain, is adjusted to provide calibrated magnified sweep rates. When the MAG switch is set to $\times 10$, the MAG ON light, B849, is connected to the +150-volt supply through R849. B849 ignites to indicate that the sweep is magnified. In the EXT HORIZ position of the HORIZ DISPLAY switch, the magnifier is connected into the circuit so the horizontal gain is correct for external horizontal operation regardless of the setting of the MAG switch. However, both sides of B1049 are connected to ground so it does not ignite.

Output Amplifier

The push-pull output of the Paraphase Amplifier is connected to the Output Amplifier. Each half of the Output Amplifier can be considered as a single-ended, feedback amplifier which amplifies the signal current at the input to produce a voltage output to drive the horizontal deflection plates of the CRT. The amplifiers have a low input impedance and require very little voltage change at the input to produce the desired output change. Diodes D851-D852 and D861-D871 protect the amplifier from being overdriven by excessive current swing at the collectors of Q834 and Q844. Negative feedback is provided from the collectors of the final transistors, Q884 and Q894, to the bases of the input

transistors through C882-R882 and C892-R892. C882 and C892 adjust the transient response of the amplifier so it has good linearity at fast sweep rates.

The Mag Register adjustment, R855, balances the quiescent DC current to the base of Q863 and Q873 so a center-screen display does not change position when the MAG switch is changed from $\times 10$ to OFF.

The TRACE FINDER switch, SW330, reduces horizontal scan by limiting the current available to Q884 and Q894. Normally the collectors of these transistors are returned to +150 volts. However, when the TRACE FINDER switch is pressed in, the power from the unregulated +150-volt supply is interrupted and the collector voltage for Q884 and Q894 is supplied from +75 volts through D884. Since the collectors are returned to a lower potential, the output voltage swing is reduced to limit the horizontal deflection within the graticule area.

Z AXIS AMPLIFIER

General

The Z Axis Amplifier circuit controls the CRT intensity level from several inputs. The effect of these input signals is to either increase or decrease the trace intensity, or to completely blank portions of the display. Fig. 3-15 shows a detailed block diagram of the Z Axis Amplifier circuit. A schematic of this circuit is shown on diagram 16 at the rear of this manual.

Input Amplifier

The input transistor, Q1014, in the Input Amplifier stage is a current-driven, low-input impedance amplifier. It provides termination for the input signals as well as isolation between the input signals and the following stages. The current signals from the various control sources are connected to the emitter of Q1014 and the sum or difference of the signals determines the collector conduction level. D1015 and D1016 in the collector provide limiting protection at minimum intensity. When the INTENSITY control is set fully counterclockwise (minimum), the collector current of Q1014 is reduced and its collector rises positive. D1015 is reverse biased to block the control current at the base of Q1023, and D1016 is forward biased to protect the circuit by clamping the collector of Q1014 about 0.5 volts more positive than the emitter level of Q1023. This limiting action also takes place when a blanking signal is applied. The clamping of D1016 allows Q1014 to recover faster to produce a sharper display with sudden changes in blanking level. At normal intensity levels, D1016 is reverse biased and the signal from Q1014 is coupled to emitter follower Q1023 through D1015.

The input signals vary the current drive to the emitter of Q1014, which produces a collector level that determines the brilliance of the display. The INTENSITY control sets the quiescent level at the emitter of Q1014. When R1005 is turned in the clockwise direction, more current from the INTENSITY control is added to the emitter circuit of Q1014 which results in an increase in collector current to provide a brighter trace. However, the vertical chopped blanking, Z Axis Input and A and B unblanking signals determine whether the trace is visible. The vertical chopped blanking signal blanks the trace during dual-trace switching. This signal

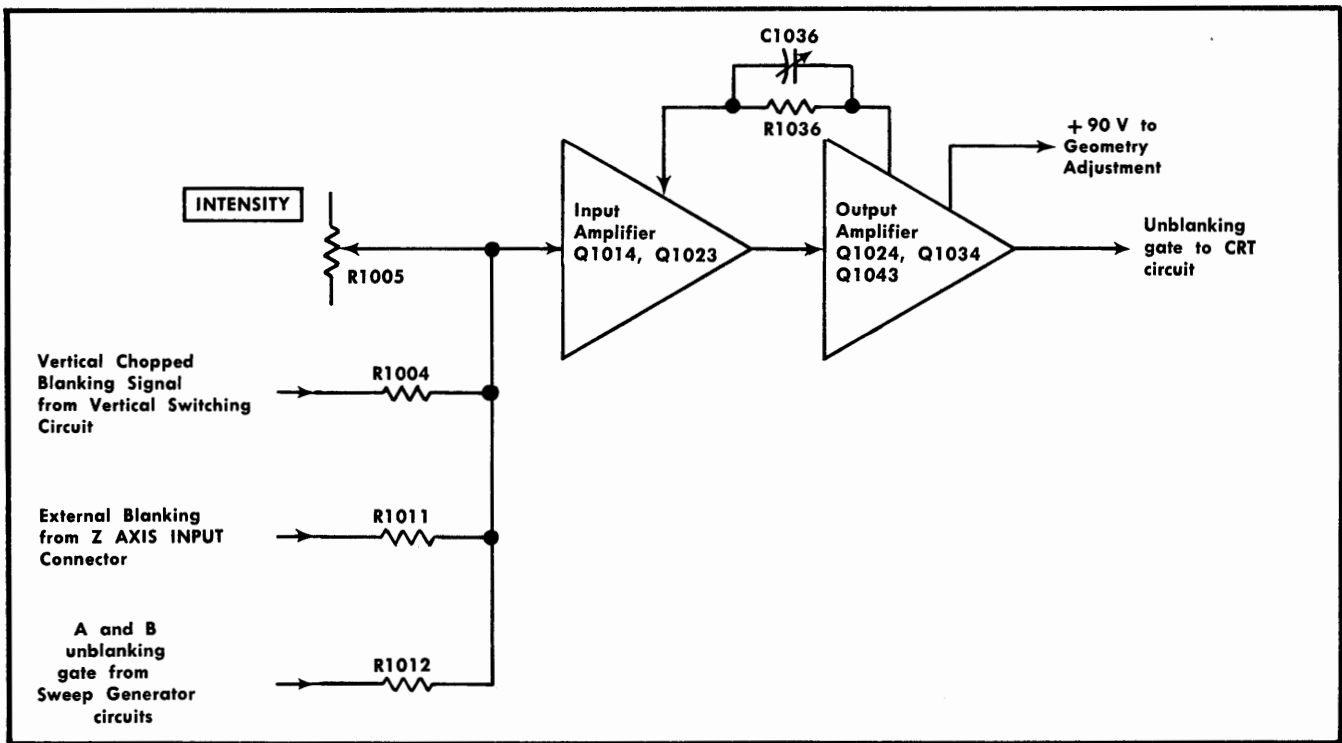

Fig. 3-15. Z Axis Amplifier detailed block diagram.

decreases the current through Q1014 during the trace switching time to blank the CRT display. The external blanking input allows an external signal connected to the Z AXIS INPUT connector to change the trace intensity. A positive-going signal connected to the Z AXIS INPUT connector decreases trace intensity and a negative-going signal increases trace intensity. The A and B unblanking gate signals from the A and B Sweep Generator circuits blank the CRT during sweep retrace and recovery time so there is no display on the screen. When the Sweep Generator circuits are reset and recovered, (see A and B Sweep Generator discussion for more information) the next trigger initiates the sweep and an unblanking gate signal is generated in the A or B Sweep Generator circuit that goes negative to allow the emitter current to reach the level established by the INTENSITY control and the other blanking inputs.

Output Amplifier

The resultant signal produced from the various inputs by the Input Amplifier stage is connected to the base of Q1024 through C1029 and to the base of Q1034 through R1024. These transistors are connected as a collector-coupled complementary amplifier. This configuration provides a linear, fast output signal with minimum quiescent power.

The Z Axis Amplifier circuit is a shunt-feedback operational amplifier with feedback from the Output Amplifier stage to the Input Amplifier stage through C1036-C1037-R1036. The output voltage is determined by the input current times the feedback resistor and is shown by the formula; $E_{out} = i_{in} \times R_{fb}$ where R_{fb} is R1036. The unblanking input current change is approximately two milliamperes. Therefore, the output voltage change is about 60 volts ($2 \text{ mA} \times 30.1 \text{ k}\Omega$). C1036

adjusts the feedback circuit for optimum high-frequency response.

Zener diode D1043 connected between +75 volts and +150 volts through D1044, R1044 and R1043 produces a +90-volt level at the cathode of D1043. This voltage establishes the correct operating level for the Geometry adjustment in the CRT Circuit and establishes the correct collector level for Q1043. D1045 connected from base to emitter of Q1043 improves the response of Q1043 to negative-going signals. When the base of Q1043 is driven negative to cutoff, D1045 is forward biased and conducts the negative-going portion of the unblanking signal. This provides a fast falling edge on the unblanking gate to quickly turn the display off. The output unblanking gate at the emitter of Q1043 is connected to the CRT circuit through R1046.

CRT CIRCUIT

General

The CRT Circuit provides the high voltage and control circuits necessary for operation of the cathode-ray tube (CRT). Fig. 3-16 shows a detailed block diagram of the CRT Circuit. A schematic of this circuit is shown on diagram 16 at the rear of this manual.

High-Voltage Oscillator

Q930 and associated circuitry comprise a class C oscillator¹⁰ to produce the drive for the high-voltage transformer, T930. When the instrument is turned on, the current through R925 charges C913 positive and Q930 is forward biased.

¹⁰Lloyd P. Hunter, pp. 14-19—14-21.

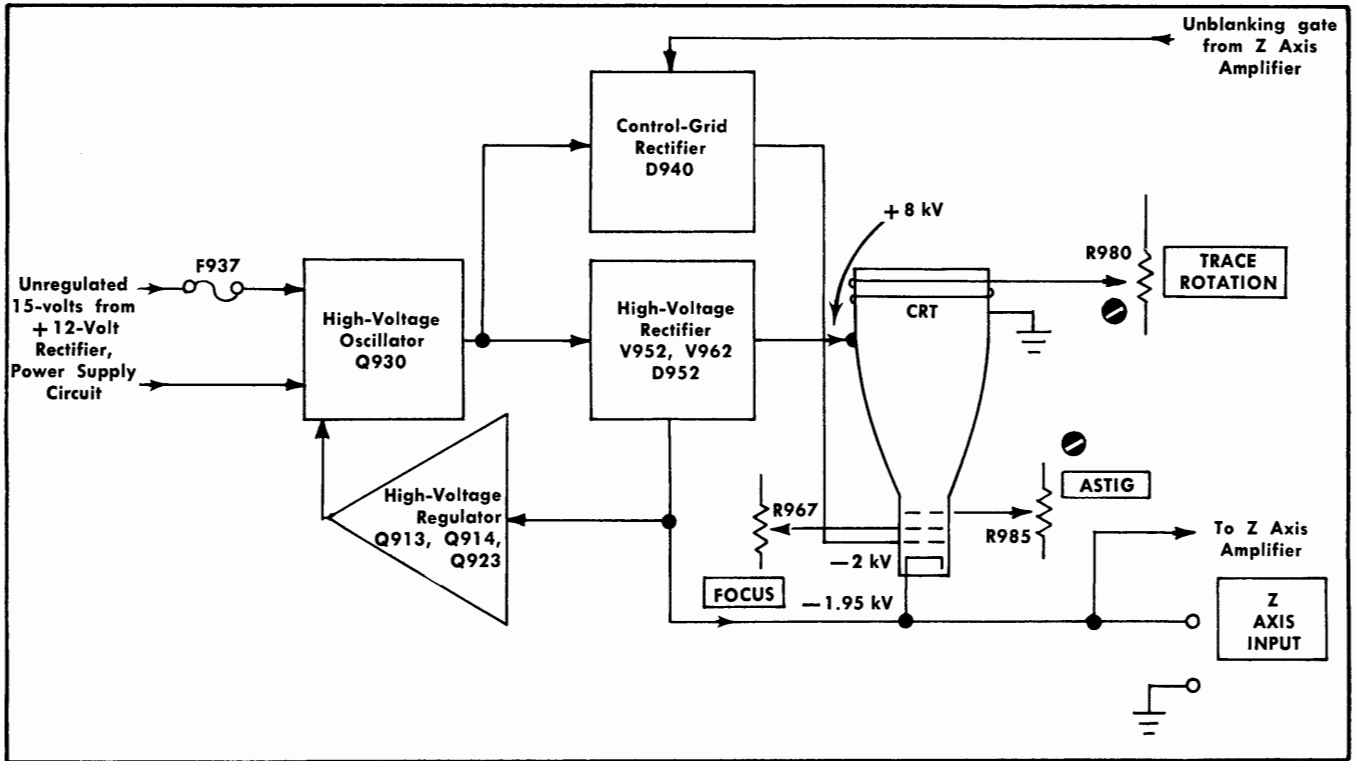

Fig. 3-16. CRT Circuit detailed block diagram.

The collector current of Q930 increases and a voltage is developed across the collector winding of T930. This produces a corresponding voltage increase in the feedback winding of T930 which is connected to the base of Q930, and it conducts even harder. While Q930 is on, its base current exceeds the current through R925 and C913 charges negatively. Eventually the rate of collector current increase in Q930 becomes less than that required to maintain the voltage across the collector winding and the output voltage drops. This turns off Q930 by way of the feedback voltage to the base. The voltage waveform at the collector of Q930 is a sine wave at the resonant frequency of T930. Q930 remains off until a little less than one cycle later when C913 discharges sufficiently to raise the voltage at the base of Q930 positive enough to bias Q930 into conduction again. The cycle repeats at a frequency of 40 to 50 kilohertz. The amplitude of sustained oscillation depends upon the average current delivered to the base of Q930.

Fuse F937 protects the +12-volt Supply if the High-Voltage Oscillator stage is shorted. C937 and L937 prevent the current changes at the collector of Q930 from affecting the +12-volt regulator circuit.

High-Voltage Regulator

Feedback from the secondary of T930 is connected to the base of Q914 through the voltage divider network R901-R910. This sample of the output voltage is compared to the -12-volt level at the emitter of Q914. It is then amplified by Q914 and Q913 and applied to the base of Q923. Amplitude of the oscillations at the collector of Q930

is determined by the average DC level at the emitter of Q923.

Regulation takes place as follows: If the output voltage at the -1950 V test point starts to go positive (less negative), a sample of this positive-going voltage is applied to the base of Q914. Q914 is forward biased and it, in turn, forward biases Q913 to increase the conduction of Q923. An increase in current through Q923 raises the average voltage level of its emitter which is connected to the base of Q930 through the feedback winding of T930. A more positive level at the base of Q930 increases the collector current to produce a larger induced voltage in the secondary of T930. This increased voltage appears as a more negative voltage at the -1950 V test point to correct the original positive-going change. By sampling the output from the cathode supply in this manner, the total output of the high-voltage supply is held constant.

Output voltage level of the high-voltage supply is controlled by the High Voltage adjustment, R900, in the base circuit of Q914. This adjustment sets the conduction level of Q914 which controls the quiescent conduction of Q913, Q923 and Q930 similar to the manner just described for a change in output voltage.

High Voltage Rectifiers and Output

Below serial number 44360, the high-voltage transformer, T930 has five output windings. Two of these windings provide filament voltage for the rectifier tubes, V952 and V962. Serial number 44360 and above, rectifier tubes V952 and

V962 are replaced by silicon high-voltage rectifier diodes D951 and D961 and there is no further need for the windings that provided filament voltage to the rectifier tubes. An additional low-voltage winding provides the filament voltage for the cathode-ray tube.

Positive accelerating potential is supplied by voltage doubler D951 and D961 (V952 and V962 below serial number 44360). Regulated voltage output is about +8 kilovolts. Ground return for this supply is through the resistive helix inside the cathode-ray tube to pin 7 and then to ground through R972.

The negative accelerating potential for the CRT cathode is supplied by the half-wave rectifier D952. Voltage output is about -1.95 kilovolts. A sample of this output voltage is connected to the High-Voltage Regulator stage to provide a regulated high-voltage output.

The half-wave rectifier D940 provides a negative voltage for the control grid of the CRT. Output level is adjustable by R940, CRT Grid Bias adjustment. The neon bulbs B973, B974 and B975 provide protection if the voltage difference between the control grid and cathode exceeds about 165 volts. The unblanking gate from the Z Axis Amplifier is applied to the positive side of this circuit to produce a change in output voltage to control CRT intensity, unblanking, dual-trace blanking and intensity modulation.

CRT Control Circuits

Focus of the CRT display is controlled by the FOCUS control, R967. Divider R963-R968 is connected between the CRT cathode supply and ground. The voltage applied to the focus grid is more positive (closer to ground level) than the voltage on either the control grid or the CRT cathode. The ASTIG adjustment, R985, which is used in conjunction with the FOCUS control to provide a well-defined display, varies the positive level on the astigmatism grid. The +90-volt source for this control is provided by zener diode D1043 in the Z Axis Amplifier circuit.

Geometry adjustment, R982, varies the positive level on the horizontal deflection plate shields to control the overall geometry of the display. Two adjustments control the trace alignment by varying the magnetic fields around the CRT. The Y Axis Align adjustment, R989, controls the current through L989 which affects the CRT beam after vertical deflection but before horizontal deflection. The TRACE ROTATION adjustment, R980, controls the current through L980 and affects both vertical and horizontal rotation of the beam.

External Z Axis Input

A signal applied to the Z AXIS INPUT connector (see Z Axis Amplifier schematic) is applied to the CRT cathode through C979-C976-R976. DC and low frequency Z-axis signals are blocked from the CRT circuit by C979. They are connected to the Z Axis Amplifier circuit to produce an increase or decrease in intensity, depending upon polarity. C976 and C979 couple high-frequency signals directly to the CRT cathode to produce the same resultant display as the Z Axis Amplifier circuit produces for low-frequency signals.

This configuration operates as a crossover network to provide nearly constant intensity modulation from DC to 50 megahertz.

LOW-VOLTAGE POWER SUPPLY

General

The low-voltage Power Supply circuit provides the operating power for this instrument from three regulated supplies and one unregulated supply. Electronic regulation¹¹ is used to provide stable, low-ripple output voltages. Each regulated supply contains a short-protection circuit to prevent instrument damage if a supply is inadvertently shorted to ground. The Power Input stage includes the Line Voltage Selector assembly. This assembly allows selection of the nominal operating voltage and regulating range for the instrument. Fig. 3-17 shows a detailed block diagram of the Power Supply circuit. A schematic of this circuit is shown on diagram 17 at the rear of this manual.

Power Input

Power is applied to the primary of transformer T1101 through the 115-volt line fuse F1101, POWER switch SW1101, thermal cutout TK1101, Voltage Selector switch SW1102 and Range Selector switch SW1103. The Voltage Selector switch SW1102 connects the split primaries of T1101 in parallel for 115-volt nominal operation, or in series for 230-volt nominal operation. A second line fuse, F1102, is connected into the circuit when the Voltage Selector switch is set to the 230 V position to provide the correct protection for 230-volt operation (F1102 current rating is one-half of F1101). The fan is connected across one half of the split primary winding so it always has about 115 volts applied to it (SN 20,000 to SN 30,720 only).

The Range Selector switch, SW1103, allows the instrument to regulate correctly on higher or lower than normal line voltages. Each half of the primary has taps above and below the 115-volt (230) nominal point. As the Range Selector switch, SW1103, is switched from LO to M to HI, more turns are effectively added to the primary winding and the turns ratio is decreased. This provides a fairly constant voltage in the secondary of T1101 even through the primary voltage has increased.

Thermal cutout TK1101 provides thermal protection for this instrument. If the internal temperature of the instrument exceeds a safe operating level, TK1101 opens to interrupt the applied power. When the temperature returns to a safe level, TK1101 automatically closes to reapply the power.

-12-Volt Supply

The -12-Volt Supply provides the reference voltage for the remaining supplies. The output from the secondary of T1101 is rectified by bridge rectifier D1112A-D. This voltage is filtered by C1112 and then applied to the -12-Volt Series Regulator stage to provide a stable output voltage. The Series Regulator can be compared to a variable resistance which is changed to control the output current. The current through the Series Regulator stage is controlled by the Error Amplifier to provide the correct regulated output voltage.

¹¹Cutler, pp. 559-625.

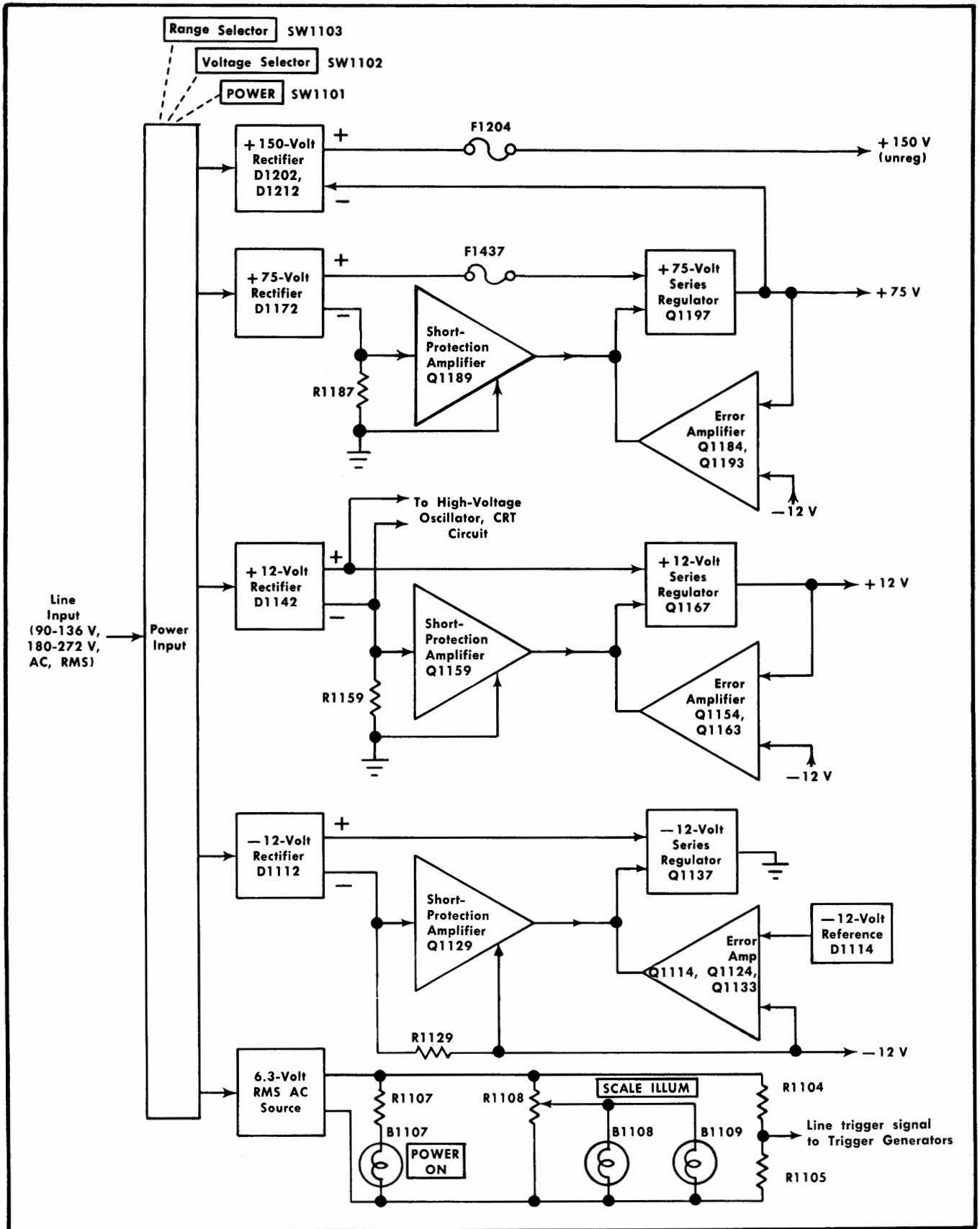

Fig. 3-17. Power Supply detailed block diagram.

The Error Amplifier is connected as a comparator. Reference voltage for the comparator is provided by zener diode D1114 which sets the base of Q1114 at about -9 volts. The base level of Q1124 is determined by voltage divider R1121-R1122-R1123 between the output of this supply and ground. R1122 is adjustable to set the output voltage of this supply to -12 volts. R1119 is the emitter resistor for both comparator transistors and the current through it divides between Q1114 and Q1124. The output current of the Error Amplifier stage controls the conduction of the Series Regulator stage (through Q1133). This output current changes to provide a constant, low-ripple -12 -volt output level. This occurs as follows: The -12 -volt regulator maintains equal voltage at the bases of the Error Amplifier transistors Q1114 and Q1124. If the -12 Volts adjustment R1122, is turned clockwise, the current through Q1124 increases (Q1124 base tends to go more positive than the base of Q1114) and the current through Q1114 decreases. Decreased current through Q1114 produces less voltage drop across R1117 and the base of Q1133 goes positive. The emitter of Q1133 pulls the base of Q1137 positive to increase the current through the load, thereby increasing the output voltage of the supply. This places more voltage across divider R1121-R1122-R1123 and the divider action returns the base of Q1124 to about -9 volts. A similar, but opposite, action takes place when R1122 is turned counterclockwise so the base of Q1124 is more negative than the base of Q1114. The -12 Volts adjustment R1122, is set to provide a -12 -volt level at the output of this supply.

The output voltage is regulated to provide a constant voltage to the load by feeding a sample of the output back to the Series Regulator, Q1137. For example, assume that the output voltage increases (more negative) because of a change in load or an increase in line voltage. This negative-going level at the output is applied across the voltage divider R1121-R1122-R1123 and the base of Q1124 goes negative also. This reduces the current flow through Q1124 which allows Q1114 to conduct more and its collector goes negative. When the collector of Q1114 goes negative, the bias on Q1133 is reduced, resulting in reduced current through the Series Regulator, Q1137. Reduced current through Q1137 also means that there is less current through the load and the output voltage decreases (less negative). In a similar manner the Series Regulator and Error Amplifier stages compensate for output changes due to ripple.

The Short-Protection Amplifier stage, Q1129, protects the -12 -Volt Supply if the output is shorted. For normal operation, the emitter-base voltage of Q1129 is not enough to bias it on. However, when the output is shorted, high current is demanded from the -12 -Volt Supply, and this current flows through R1129. The voltage drop across R1129 becomes sufficient to forward bias Q1129 and its collector current produces an increased voltage drop across R1117. The increased voltage drop across R1117 reduces the current flow of both Q1133 and Q1137 to limit the output current.

+12-Volt Supply

Rectified voltage for operation of the $+12$ -Volt Supply is provided by D1142 A-D. This voltage is filtered by C1142 and connected to the $+12$ -Volt Supply Series Regulator and to the High-Voltage Oscillator stage in the CRT Circuit. Reference voltage for this supply is provided by voltage divider R1151-R1152-R1153 between the regulated -12 volts and the output of this supply. The -12 volts is held stable by the

-12 -Volt Supply as discussed previously. If the $+12$ -volt output changes, a sample of this change appears at the base of Q1154 as an error signal. Regulation of the output voltage is controlled by the $+12$ -Volt Series Regulator stage, Q1167, in a similar manner to that described for the -12 -Volt Supply. The $+12$ Volts adjustment, R1152, sets the output level to $+12$ volts. D1152 provides thermal compensation for the Error Amplifier. C1164 improves response of the regulator circuit to AC changes at the output.

Shorting protection is provided by Q1159 and R1159. If the output of this supply is shorted, Q1159 is biased on to limit the conduction of the Series Regulator in the same manner as described for the -12 -Volt Short-Protection Amplifier. D1164 protects Q1154 when the output of this supply is shorted.

+75-Volt Supply

D1172 A-D provides the rectified voltage for the $+75$ -Volt Supply. C1172 filters the rectified voltage which is connected to the $+75$ -Volt Series Regulator. Reference voltage for this supply is provided by voltage-divider R1181-R1182-R1183 between the regulated -12 volts and the output of this supply. Since the -12 volts is held stable by the -12 -Volt Regulator circuit, any change at the base of Error Amplifier Q1184 is due to change at the output of the $+75$ -Volt Supply. Regulation of the output voltage is controlled by Error Amplifier Q1184-Q1193 and Series Regulator, Q1197, in a manner similar to that described for the $+12$ -Volt Supply. The $+75$ Volts adjustment R1182, sets the quiescent conduction level of the Error Amplifier stage to provide an output level of $+75$ volts. The output of the $+150$ -Volt Supply (unregulated) is connected to the Error Amplifier to provide the required collector supply for stable operation. Zener diode D1209 establishes a voltage at its cathode of about $+108$ volts. Then, R1186, zener diode D1185 and R1185 drop this voltage to the correct level for the operation of Q1184. D1182 provides thermal compensation for the Error Amplifier.

Q1189 provides current limiting for this supply through D1188. Quiescently, Q1189 is off under normal operating conditions, D1189 is conducting and D1188 is reverse biased. However, when the output is shorted, the increased current flow through R1187 biases Q1189 on and its collector goes negative. This forward biases D1188 and reverse biases D1189. Now Q1189 limits the collector current of Q1197 through Q1193. F1437 (F1172 below SN 39320) also provides overload protection. D1198 protects the $+75$ -volt supply from damage if it is shorted to the -12 -volt output.

+150-Volt Unregulated Supply

Rectifiers D1202 and D1212 provide the unregulated output for the $+150$ -Volt Supply. From serial number 30820 through SN 39319, the output from this secondary winding also provides the operating potential for the cooling fan motor through R1200. Serial number 39320 and above, this secondary winding contains additional taps to provide the operating potential necessary for the cooling fan motor. The output of the $+75$ -Volt Supply is connected to the negative side of the $+150$ -Volt Supply to elevate the output level to $+150$ volts. Diodes D1202 and D1212 are connected as a full-wave center-tapped rectifier and the output is filtered by C1202-C1204-R1204 to hold the output level at about $+150$ volts. Fuse F1204 protects this supply if the output is shorted.

6.3-Volt RMS AC Source

The 6.3-volt RMS secondary winding of T1101 provides power for the POWER ON light, B1107, and the scale illumination lights, B1108 and B1109. The current through the scale illumination lights is controlled by the SCALE ILLUM control, R1108, to change the illumination of the graticule line voltage to the A and B Trigger Generator circuits for line voltage to the A and B Trigger Generator circuits for internal triggering at the line frequency. C1105 reduces noise on the line frequency signal.

VOLTAGE DISTRIBUTION

Diagram 17 also shows the distribution of the output voltages from the Power Supply circuit to the circuit boards in this instrument. The decoupling networks which provide decoupled operating voltages are shown on this Diagram and are not repeated on the individual circuit diagrams.

CALIBRATOR

General

The Calibrator circuit produces a square-wave output with accurate amplitude and frequency. This output is available as a square-wave voltage at the 1 kHz CAL connector or as a square-wave current through the side-panel PROBE LOOP. Fig. 3-18 shows a detailed block diagram of the Calibrator circuit. A schematic of this circuit is shown on diagram 18 at the rear of this manual.

Oscillator

Q1255 and its associated circuitry comprise a tuned-collector oscillator.¹² Frequency of oscillation is determined by the LC circuit comprised of the primary of variable transformer T1255 in parallel with C1255. The accuracy and sta-

¹²Lloyd P. Hunter, pp. 14-3—14-7.

bility required to provide an accurate time and frequency reference is obtained by using a capacitor and transformer which have equal but opposite temperature coefficients.

The oscillations of the LC circuit, T1255-C1255, are sustained by the feedback winding of T1255 connected to the base of Q1255. C1266 connects a sample of the output of the LC circuit to the base of Q1265. The regenerative feedback from the emitter of Q1265 to the emitter of Q1255 produces fast changeover between Q1255 and Q1265 to provide a fast risetime on the output square wave. Frequency of the output square wave can be adjusted by varying the coupling to the feedback winding of T1255. The square-wave signal at the collector of Q1265 is connected to the Output Amplifier.

Output Amplifier

The output signal from the oscillator stage saturates Q1274 to produce the accurate square wave at the output. When the base of Q1274 goes positive, Q1274 is cut off and the output signal drops negative to ground. When its base goes negative, Q1274 is driven into saturation and the output signal rises positive to about +12 volts. The output of the +12-Volt Supply is adjusted for an accurate one-volt output signal at the 1 kHz CAL connector when the CALIBRATOR switch is set to 1 V.

Output Divider

The Output Divider, R1275-R1276-R1277, provides two output voltages from the Calibrator circuit. In the 1 V CALIBRATOR switch position, voltage is obtained from the collector of Q1274 through R1274. In the .1 V CALIBRATOR switch position, the output is obtained at the junction of voltage divider R1275 and R1276-R1277 to provide one-tenth of the previous output voltage.

Collector current of Q1274 flows through the PROBE LOOP on the side panel. Output current is a five-millampere square wave.

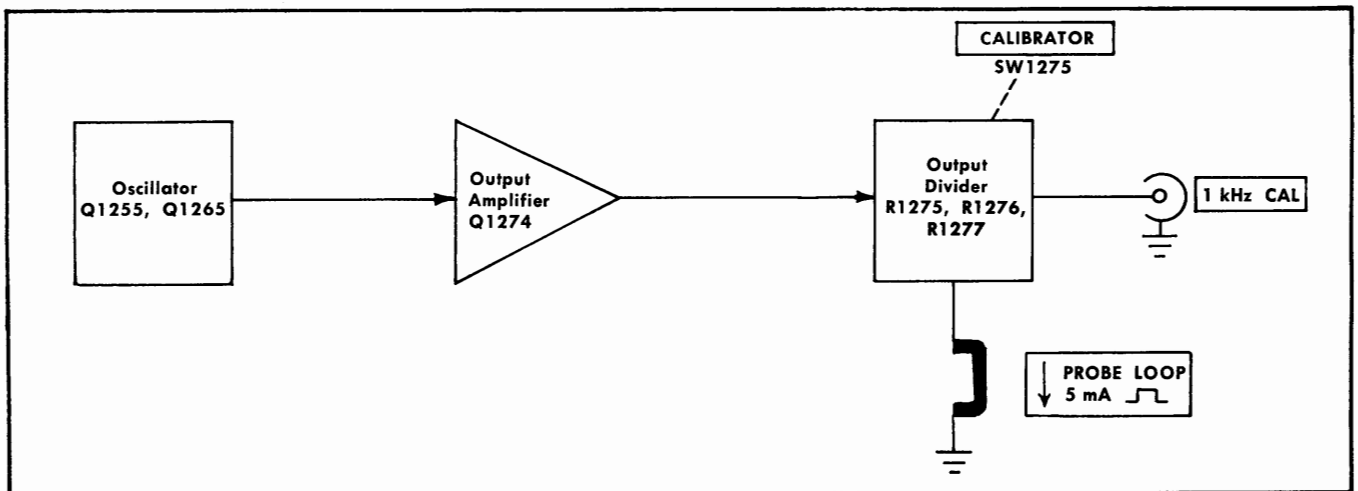

Fig. 3-18. Calibrator detailed block diagram.

SECTION 4

MAINTENANCE

Change information, if any, affecting this section is found at the rear of the manual.

Introduction

This section of the manual contains maintenance information for use in preventive maintenance, corrective maintenance or troubleshooting of the Type 453.

Cover Removal

The top and bottom covers of the instrument are held in place by thumb screws located on each side of the instrument. To remove the covers, loosen the thumb screws and slide the covers off the instrument. The covers protect the instrument from dust in the interior. The covers also direct the flow of cooling air and reduce the EMI radiation from the instrument.

PREVENTIVE MAINTENANCE

General

Preventive maintenance consists of cleaning, visual inspection, lubrication, etc. Preventive maintenance performed on a regular basis may prevent instrument breakdown and will improve the reliability of this instrument. The severity of the environment to which the Type 453 is subjected determines the frequency of maintenance. A convenient time to perform preventive maintenance is preceding recalibration of the instrument.

Cleaning

General. The Type 453 should be cleaned as often as operating conditions require. Accumulation of dirt in the instrument can cause overheating and component breakdown. Dirt on components acts as an insulating blanket and prevents efficient heat dissipation. It also provides an electrical conduction path.

CAUTION

Avoid the use of chemical cleaning agents which might damage the plastics used in this instrument. Avoid chemicals which contain benzene, toluene, xylene, acetone or similar solvents.

The top and bottom covers provide protection against dust in the interior of the instrument. Operation without the covers in place necessitates more frequent cleaning. The front cover provides dust protection for the front panel and the CRT face. The front cover should be installed for storage or transportation. The plastic cover supplied with the Type 453 provides protection for the outside of the instrument during transportation or storage. The pocket on the side also provides a convenient place to carry this instruction manual.

Air Filter. The air filter should be visually checked every few weeks and cleaned or replaced if dirty. More frequent inspections are required under severe operating conditions. The following procedure is suggested for cleaning the filter. If the filter is to be replaced, order new air filters from your local Tektronix Field Office or representative; order by Tektronix Part No. 378-0033-00.

1. Remove the filter by pulling it out of the retaining frame on the rear panel. Be careful not to drop any of the accumulated dirt into the instrument.
2. Flush the loose dirt from the filter with a stream of hot water.
3. Place the filter in a solution of mild detergent and hot water and let it soak for several minutes.
4. Squeeze the filter to wash out any dirt which remains.
5. Rinse the filter in clear water and allow it to dry.
6. Coat the dry filter with an air-filter adhesive (available from air conditioner suppliers or order Tektronix Part No. 006-0580-00).
7. Let the adhesive dry thoroughly.
8. Re-install the filter in the retaining frame.

Exterior. Loose dust accumulated on the outside of the Type 453 can be removed with a soft cloth or small paint brush. The paint brush is particularly useful for dislodging dirt on and around the front-panel controls. Dirt which remains can be removed with a soft cloth dampened in a mild detergent and water solution. Abrasive cleaners should not be used.

CRT. Clean the plastic light filter, faceplate protector and the CRT face with a soft, lint-free cloth dampened with denatured alcohol. The CRT mesh filter can be cleaned in the following manner.

1. Hold the filter in a vertical position and brush lightly with a soft #7 water-color brush to remove light coatings of dust or lint.
2. Greasy residues or dried-on dirt can be removed with a solution of warm water and a neutral-pH liquid detergent. Use the brush to lightly scrub the filter.
3. Rinse the filter thoroughly in clean water and allow to air dry.
4. If any lint or dirt remains, use clean low-pressure air to remove. Do not use tweezers or other hard cleaning tools on the filter, as the special finish may be damaged.
5. When not in use, store the mesh filter in a lint-free, dust-proof container such as a plastic bag.

Maintenance—Type 453/R453

Interior. Dust in the interior of the instrument should be removed occasionally due to its electrical conductivity under high-humidity conditions. The best way to clean the interior is to blow off the accumulated dust with dry, low-velocity air. Remove any dirt which remains with a soft paint brush or a cloth dampened with a mild detergent and water solution. A cotton-tipped applicator is useful for cleaning in narrow spaces or for cleaning ceramic terminal strips and circuit boards.

The high-voltage circuits, particularly parts located in the high-voltage compartment and the area surrounding the post-deflection anode connector, should receive special attention. Excessive dirt in these areas may cause high-voltage arcing and result in improper instrument operation.

Lubrication

General. The reliability of potentiometers, rotary switches and other moving parts can be maintained if they are kept properly lubricated. Use a cleaning-type lubricant (e.g., Tektronix Part No. 006-0218-00) on switch contacts. Lubricate switch detents with a heavier grease (e.g., Tektronix Part No. 006-0219-00). Potentiometers which are not permanently sealed should be lubricated with a lubricant which does not affect electrical characteristics (e.g., Tektronix Part No. 006-0220-00). The pot lubricant can also be used on shaft bushings. Do not over-lubricate. A lubrication kit containing the necessary lubricants and instructions is available from Tektronix, Inc. Order Tektronix Part No. 003-0342-00.

Fan. The fan-motor bearings are sealed and do not require lubrication.

Visual Inspection

The Type 453 should be inspected occasionally for such defects as broken connections, broken or damaged ceramic strips, improperly seated transistors, damaged circuit boards and heat-damaged parts.

The corrective procedure for most visible defects is obvious; however, particular care must be taken if heat-damaged components are found. Overheating usually indicates other trouble in the instrument; therefore, it is important that the cause of over-heating be corrected to prevent recurrence of the damage.

Transistor Checks

Periodic checks of the transistors in the Type 453 are not recommended. The best check of transistor performance is its actual operation in the instrument. More details on checking transistor operation is given under Troubleshooting.

Recalibration

To assure accurate measurements, check the calibration of this instrument after each 1000 hours of operation or every six months if used infrequently. In addition, replacement of components may necessitate recalibration of the affected circuits. Complete calibration instructions are given in the Calibration section.

The calibration procedure can also be helpful in localizing certain troubles in the instrument. In some cases, minor

troubles may be revealed and/or corrected by recalibration.

TROUBLESHOOTING

Introduction

The following information is provided to facilitate troubleshooting of the Type 453. Information contained in other sections of this manual should be used along with the following information to aid in locating the defective component. An understanding of the circuit operation is very helpful in locating troubles. See the Circuit Description section for complete information.

Troubleshooting Aids

Diagrams. Circuit diagrams are given on foldout pages in Section 9. The component number and electrical value of each component in this instrument are shown on the diagrams. Each main circuit is assigned a series of component numbers. Table 4-1 lists the main circuits in the Type 453 and the series of component numbers assigned to each. Important voltages and waveforms are also shown on the diagrams. The portions of the circuit mounted on circuit boards are enclosed with a blue line.

TABLE 4-1
Component Numbers

Component Numbers on Diagrams	Diagram Number	Circuit
1-99	1	Channel 1 Vertical Preamp
100-199	3	Channel 2 Vertical Preamp
200-299	5	Vertical Switching
300-399	6	Vertical Output Amplifier
400-429	7	Trigger Preamp
430-499	8	A Trigger Generator
500-599	9	A Sweep Generator
600-699	10	B Trigger Generator
700-799	11	B Sweep Generator
800-899	13	Horizontal Amplifier
900-999	16	CRT Circuit
1000-1099	15	Z Axis Amplifier
1100-1199	17	Power Supply and Distribution
1250-1299	18	Calibrator

Switch Wafer Identification. Switch wafers shown on the diagrams are coded to indicate the position of the wafer in the complete switch assembly. The numbered portion of the code refers to the wafer number counting from the front, or mounting end of the switch, toward the rear. The letters F and R indicate whether the front or rear of the wafer performs the particular switching function. For example, a wafer designated 2R indicates that the rear of the second wafer from the front is used for this particular switching function.

Circuit Boards. Fig. 4-6 through 4-14 show the circuit boards used in the Type 453. Fig. 4-5 shows the location of each board within the instrument. Each electrical component on the boards is identified by its circuit number.

The circuit boards are also outlined on the diagrams with a blue line. These pictures, used along with the diagrams, aid in locating the components mounted on the circuit boards.

Wiring Color-Code. All insulated wire and cable used in the Type 453 is color-coded to facilitate circuit tracing. Signal carrying leads are identified with one or two colored stripes. Voltage supply leads are identified with three stripes to indicate the approximate voltage using the EIA resistor color code. A white background color indicates a positive voltage and a tan background indicates a negative voltage. The widest color stripe identifies the first color of the code. Table 4-2 gives the wiring color-code for the power-supply voltages used in the Type 453.

TABLE 4-2
Power Supply Wiring Color Code

Supply	Back-ground Color	First Stripe	Second Stripe	Third Stripe
-12 volt	Tan	Brown	Red	Black
+12 volt	White	Brown	Red	Black
+75 volt	White	Violet	Green	Black
+150 volt	White	Brown	Green	Brown

Resistor Color-Code. In addition to the brown composition resistors, some metal-film resistors and some wire-wound resistors are used in the Type 453. The resistance values of wire-wound resistors are printed on the body of the component. The resistance values of composition resistors and metal-film resistors are color-coded on the components with EIA color-code (some metal-film resistors may have the value printed on the body). The color-code is read starting with the stripe nearest the end of the resistor. Composition resistors have four stripes which consist of two significant figures, a multiplier and a tolerance value (see Fig. 4-1). Metal-film resistors have five stripes consisting of three significant figures, a multiplier and a tolerance value.

Capacitor Marking. The capacitance values of common disc capacitors and small electrolytics are marked in microfarads on the side of the component body. The white ceramic capacitors used in the Type 453 are color coded in picofarads using modified EIA code (see Fig. 4-1).

Diode Color Code. The cathode end of each glass-encased diode is indicated by a stripe, a series of stripes or a dot. For most silicon or germanium diodes with a series of stripes, the color-code also indicates the type of diode and identifies the Tektronix Part Number using the resistor color-code system (e.g., a diode color-coded blue-brown-gray-green indicates diode type 6185 with Tektronix Part Number

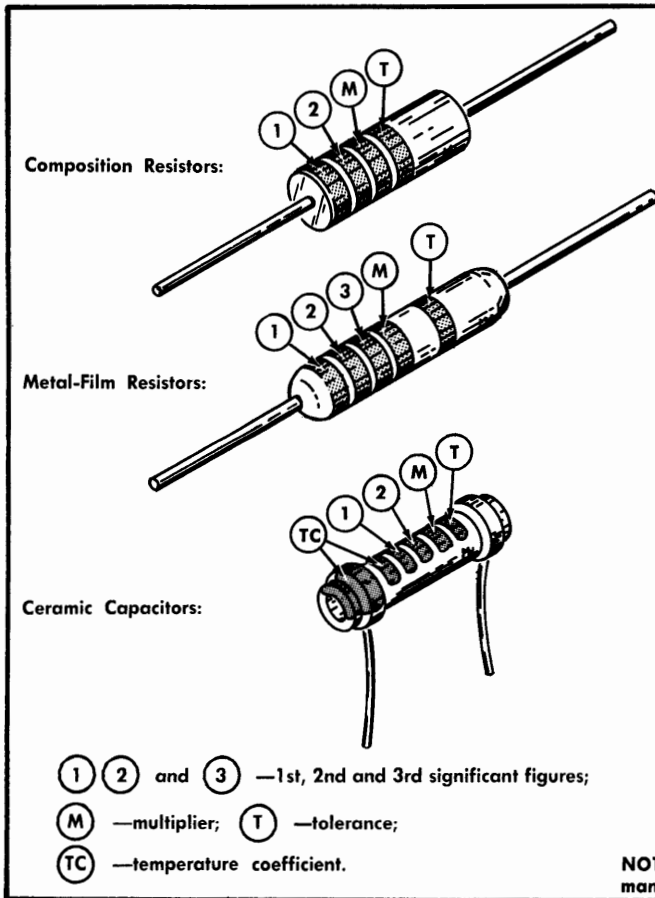

Resistor and Capacitor Color Code

Color	Significant Figures	Multiplier		Tolerance	
		Resistors	Capacitors	Resistors	Capacitors
Silver	---	10 ⁻²	---	±10%	---
Gold	---	10 ⁻¹	---	±5%	---
Black	0	1	1	---	±20% or 2 pF*
Brown	1	10	10	±1%	±1% or 0.1 pF*
Red	2	10 ²	10 ²	±2%	±2%
Orange	3	10 ³	10 ³	±3%	±3%
Yellow	4	10 ⁴	10 ⁴	±4%	+100% -0%
Green	5	10 ⁵	10 ⁵	±0.5%	±5% or 0.5 pF*
Blue	6	10 ⁶	10 ⁶	---	---
Violet	7	---	---	---	---
Gray	8	---	10 ⁻²	---	+80% -20% or 0.25 pF*
White	9	---	10 ⁻¹	---	±10% or 1 pF*
(none)	---	---	---	±20%	±10% or 1 pF*

*For capacitance of 10 pF or less.

NOTE: (T) and/or (TC) color code for capacitors depends upon manufacturer and capacitor type. May not be present in some cases.

Fig. 4-1. Color code for resistors and ceramic capacitors.

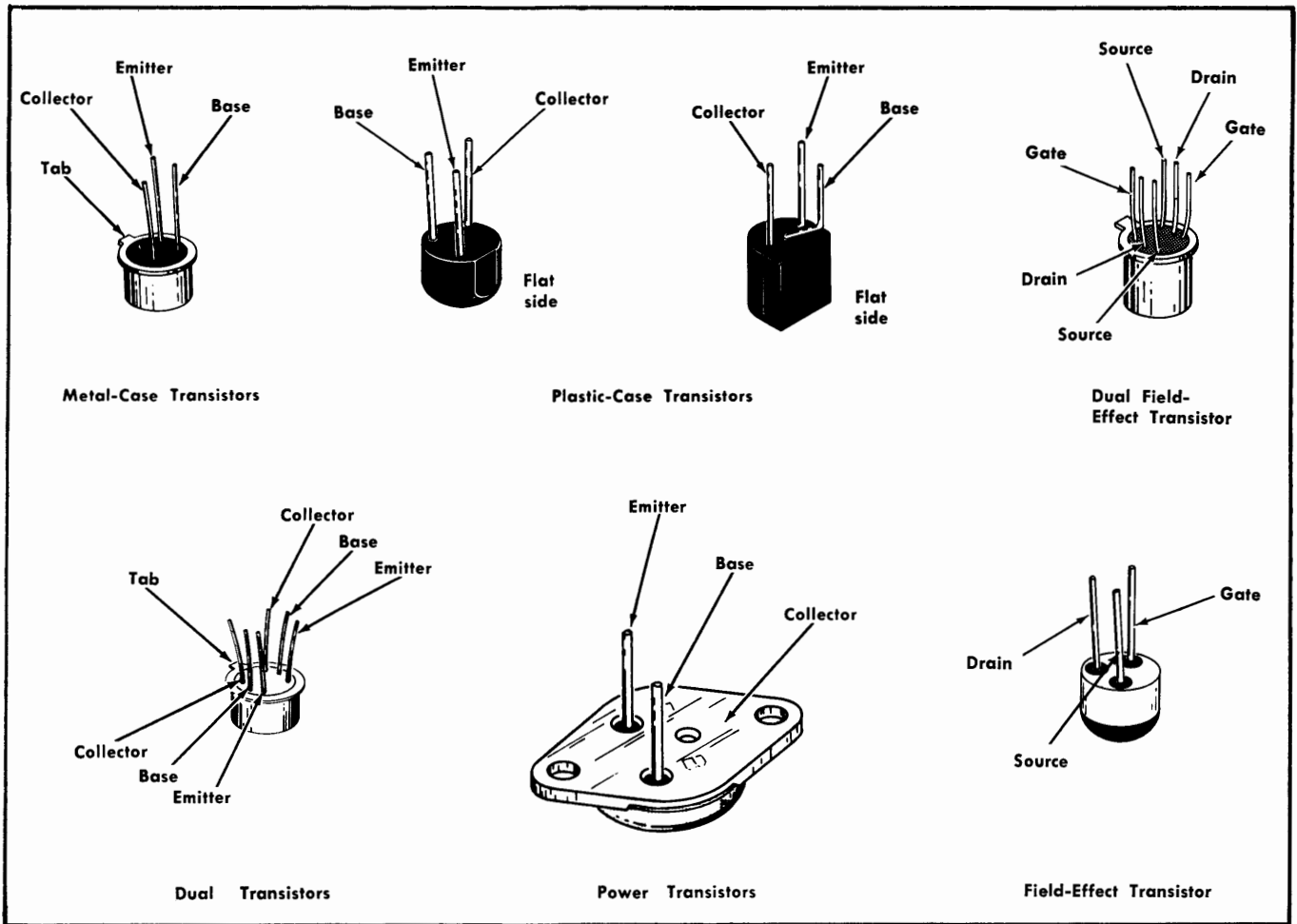

Fig. 4-2. Electrode configuration for semiconductors in this instrument.

152-0185-00). The cathode and anode end of metal-encased diodes can be identified by the diode symbol marked on the body.

Transistor Lead Configuration. Fig. 4-2 shows the lead configurations of the transistors used in this instrument. This view is as seen from the bottom of the transistors.

Troubleshooting Equipment

The following equipment is useful for troubleshooting the Type 453.

1. Transistor Tester

Description: Tektronix Type 575 Transistor-Curve Tracer or equivalent.

Purpose: To test the semiconductors used in this instrument.

2. Multimeter

Description: VTVM, 10 megohm input impedance and 0 to 500 volts range; ohmmeter, 0 to 50 megohms. Accuracy, within 3%. Test prods must be insulated to prevent accidental shorting.

Purpose: To check voltages and for general troubleshooting in this instrument.

NOTE

A 20,000 ohms/volt VOM can be used to check the voltages in this instrument if allowances are made for the circuit loading of the VOM at high-impedance points.

3. Test Oscilloscope

Description: DC to 20 MHz frequency response. 5 millivolts to 10 volts/division deflection factor. Use a 10X probe.

Purpose: To check waveforms in this instrument.

Troubleshooting Techniques

This troubleshooting procedure is arranged in an order which checks the simple possibilities before proceeding with extensive troubleshooting. The first few checks assure proper connection, operation and calibration. If the trouble is not located by these checks, the remaining steps aid in locating the defective component. When the defective component is located, it should be replaced following the replacement procedures given under Corrective Maintenance.

1. Check Control Settings. Incorrect control settings can indicate a trouble that does not exist. If there is any question about the correct function or operation of any control, see the Operating Instructions section of this manual.

2. Check Associated Equipment. Before proceeding with troubleshooting of the Type 453, check that the equipment used with this instrument is operating correctly. Check that the signal is properly connected and that the interconnecting cables are not defective. Also, check the power source.

3. Visual Check. Visually check the portion of the instrument in which the trouble is located. Many troubles can be located by visual indications such as unsoldered connections, broken wires, damaged circuit boards, damaged components, etc.

4. Check Instrument Calibration. Check the calibration of this instrument, or the affected circuit if the trouble exists in one circuit. The apparent trouble may only be a result of misadjustment or may be corrected by calibration. Complete calibration instructions are given in the Calibration section of this manual.

5. Isolate Trouble to a Circuit. To isolate trouble to a circuit, note the trouble symptom. The symptom often identifies the circuit in which the trouble is located. For example, poor focus indicates that the CRT (includes high voltage) circuit is probably at fault. When trouble symptoms appear in more than one circuit, check affected circuits by taking voltage and waveform readings. Also check for the correct output signals at the side-panel output connectors with a test oscilloscope. If the signal is correct, the circuit is working correctly up to that point. For example, correct amplitude and time of the A Gate out waveform indicates that the A Trigger Generator and A Sweep Gate circuits are operating correctly.

Incorrect operation of all circuits often indicates trouble in the power supply. Check first for correct voltage of the individual supplies. However, a defective component elsewhere in the instrument can appear as a power-supply trouble and may also affect the operation of other circuits. Table 4-3 lists the tolerances of the power supplies in this instrument. If a power-supply voltage is within the listed tolerance, the supply can be assumed to be working correctly. If outside the tolerance, the supply may be misadjusted or operating incorrectly. Use the procedure given in the Calibration section to adjust the power supplies.

TABLE 4-3
Power Supply Tolerance

Power Supply	Tolerance
-12 volt	±0.12 volt
+12 volt	12.1 volts, ±0.21 volt ¹
+75 volt	±0.75 volt
-1950 volt	±58.5 volts

¹Adjusted for correct output from the Calibrator circuit; see Calibration procedure.

Fig. 4-3 provides a guide to aid in locating a defective circuit. This chart may not include checks for all possible defects; use steps 6—8 in such cases. Start from the top of the chart and perform the given checks on the left side of

the page until a step is found which is not correct. Further checks and/or the circuit in which the trouble is probably located are listed to the right of this step.

After the defective circuit has been located, proceed with steps 6 through 8 to locate the defective component(s).

6. Check Circuit Board Interconnections. After the trouble has been isolated to a particular circuit, check the pin connectors on the circuit board for correct connection. Figs. 4-8 through 4-16 show the correct connections for each board.

The pin connectors used in this instrument also provide a convenient means of circuit isolation. For example, a short in a power supply can be isolated to the power supply itself by disconnecting the pin connectors for that voltage at the remaining boards.

7. Check Voltage and Waveforms. Often the defective component can be located by checking for the correct voltage or waveform in the circuit. Typical voltages and waveforms are given on the diagrams.

NOTE

Voltages and waveforms given on the diagrams are not absolute and may vary slightly between instruments. To obtain operating conditions similar to those used to take these readings, see the first diagram page.

8. Check Individual Components. The following procedures describe methods of checking individual components in the Type 453. Components which are soldered in place are best checked by disconnecting one end. This isolates the measurement from the effects of surrounding circuitry.

A. TRANSISTORS. The best check of transistor operation is actual performance under operating conditions. If a transistor is suspected of being defective, it can best be checked by substituting a new component or one which has been checked previously. However, be sure that circuit conditions are not such that a replacement transistor might also be damaged. If substitute transistors are not available, use a dynamic tester (such as Tektronix Type 575). Static-type testers are not recommended, since they do not check operation under simulated operating conditions.

B. DIODES. A diode can be checked for an open or shorted condition by measuring the resistance between terminals. With an ohmmeter scale having an internal source of between 800 millivolts and 3 volts, the resistance should be very high in one direction and very low when the leads are reversed.

CAUTION

Do not use an ohmmeter scale that has a high internal current. High currents may damage the diode. Do not measure tunnel diodes with an ohmmeter; use a dynamic tester (such as a Tektronix Type 575 Transistor-Curve Tracer).

C. RESISTORS. Check the resistors with an ohmmeter. Check the Electrical Parts List for the tolerance of the resistors used in this instrument. Resistors normally do not need to be replaced unless the measured value varies widely from the specified value.

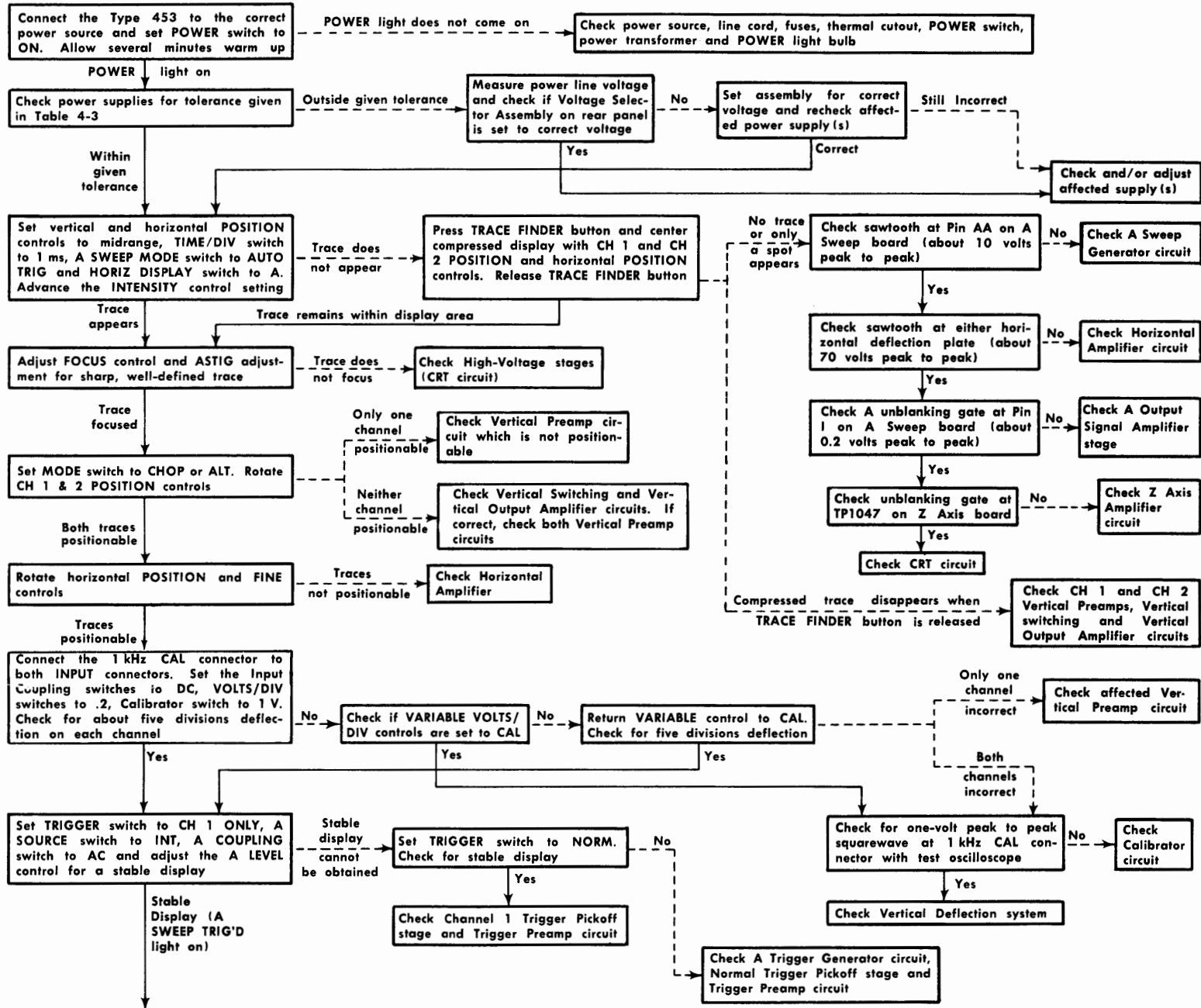

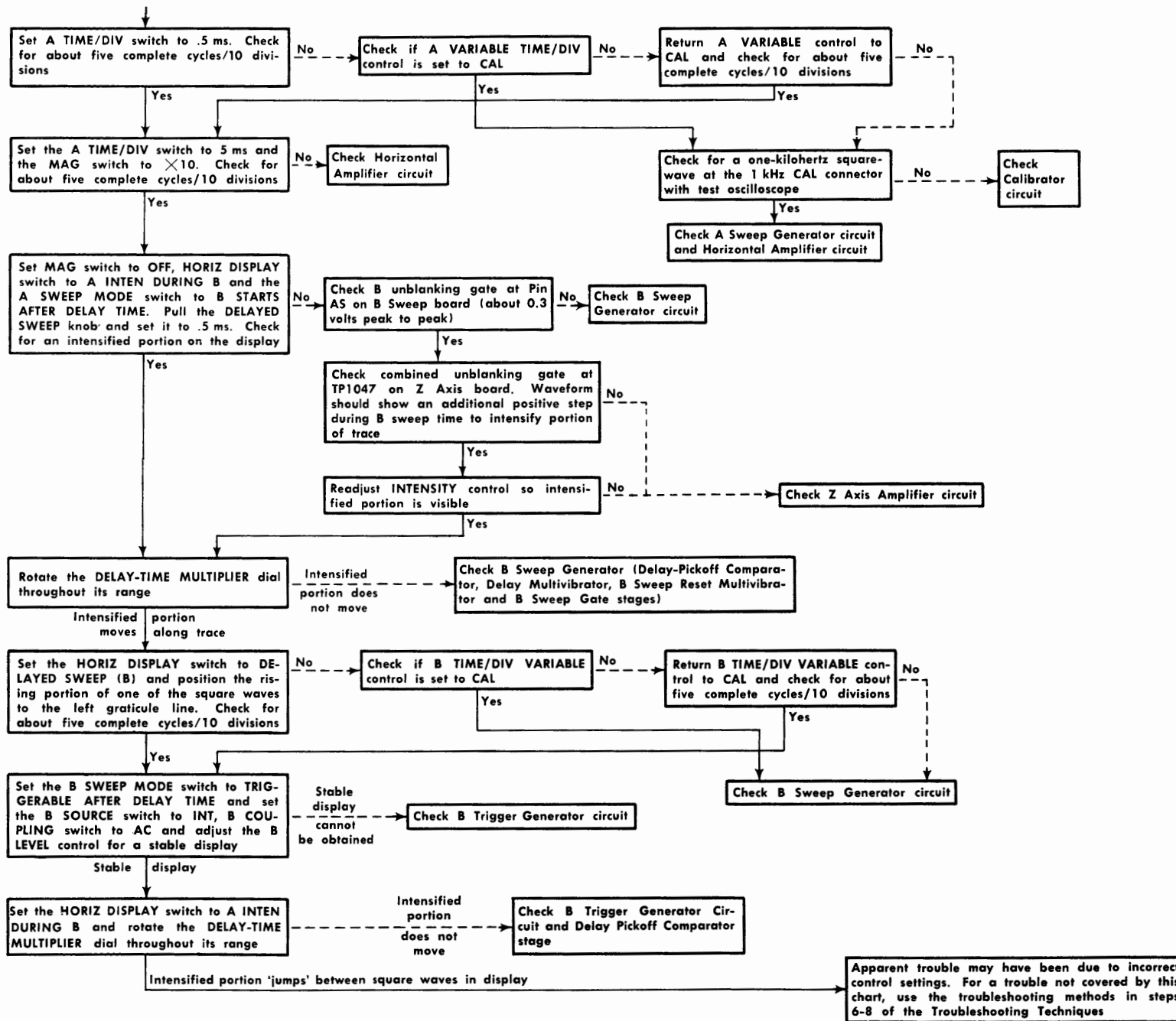

Fig. 4-3. Troubleshooting chart for Type 453.

Maintenance—Type 453/R453

D. **INDUCTORS.** Check for open inductors by checking continuity with an ohmmeter. Shorted or partially shorted inductors can usually be found by checking the waveform response when high-frequency signals are passed through the circuit. Partial shorting often reduces high-frequency response (roll-off).

E. **CAPACITORS.** A leaky or shorted capacitor can best be detected by checking resistance with an ohmmeter on the highest scale. Do not exceed the voltage rating of the capacitor. The resistance reading should be high after initial charge of the capacitor. An open capacitor can best be detected with a capacitance meter or by checking whether the capacitor passes AC signals.

9. Repair and Readjust the Circuit. If any defective parts are located, follow the replacement procedures given in this section. Be sure to check the performance of any circuit that has been repaired or that has had any electrical components replaced.

CORRECTIVE MAINTENANCE

General

Corrective maintenance consists of component replacement and instrument repair. Special techniques required to replace components in this instrument are given here.

Obtaining Replacement Parts

Standard Parts. All electrical and mechanical part replacements for the Type 453 can be obtained through your local Tektronix Field Office or representative. However, many of the standard electronic components can be obtained locally in less time that is required to order them from Tektronix, Inc. Before purchasing or ordering replacement parts, check the parts lists for value, tolerance, rating and description.

NOTE

When selecting replacement parts, it is important to remember that the physical size and shape of a component may affect its performance in the instrument, particularly at high frequencies. All replacement parts should be direct replacements unless it is known that a different component will not adversely affect instrument performance.

Special Parts. In addition to the standard electronic components, some special components are used in the Type 453. These components are manufactured or selected by Tektronix, Inc. to meet specific performance requirements, or are manufactured for Tektronix, Inc. in accordance with our specifications. These special components are indicated in the Electrical Parts List by an asterisk preceding the part number. Most of the mechanical parts used in this instrument have been manufactured by Tektronix, Inc. Order all special parts directly from your local Tektronix Field Office or representative.

Ordering Parts. When ordering replacement parts from Tektronix, Inc., include the following information:

1. Instrument type.

2. Instrument serial number.

3. A description of the part (if electrical, include circuit number).

4. Tektronix Part Number.

Soldering Techniques

WARNING

Disconnect the instrument from the power source before soldering.

Circuit Boards. Use ordinary 60/40 solder and a 35- to 40-watt pencil type soldering iron on the circuit boards. The tip of the iron should be clean and properly tinned for best heat transfer to the solder joint. A higher wattage soldering iron may separate the wiring from the base material.

The following technique should be used to replace a component on a circuit board. Most components can be replaced without removing the boards from the instrument.

1. Grip the component lead with long-nose pliers. Touch the soldering iron to the lead at the solder connection. Do not lay the iron directly on the board.

2. When the solder begins to melt, pull the lead out gently. This should leave a clean hole in the board. If not, the hole can be cleaned by reheating the solder and placing a sharp object such as a toothpick into the hole to clean it out. A vacuum-type desoldering tool can also be used for this purpose.

3. Bend the leads of the new component to fit the holes in the board. If the component is replaced while the board is mounted in the instrument, cut the leads so they will just protrude through the board. Insert the leads into the holes in the board so the component is firmly seated against the board (or as positioned originally). If it does not seat properly, heat the solder and gently press the component into place.

4. Touch the iron to the connection and apply a small amount of solder to make a firm solder joint; do not apply too much solder. To protect heat-sensitive components, hold the lead between the component body and the solder joint with a pair of long nose pliers or other heat sink.

5. Clip the excess lead that protrudes through the board.

6. Clean the area around the solder connection with a flux-remover solvent. Be careful not to remove information printed on the board.

Ceramic Terminal Strips. Solder used on the ceramic terminal strips should contain about 3% silver. Use a 40- to 75-watt soldering iron with a 1/8-inch wide wedge-shaped tip. Ordinary solder can be used occasionally without damage to the ceramic terminal strips. However, if ordinary solder is used repeatedly or if excessive heat is applied, the solder-to-ceramic bond may be broken.

A sample roll of solder containing about 3% silver is mounted on the rear subpanel of this instrument. Additional solder of the same type should be available locally, or it can be purchased from Tektronix, Inc. in one-pound rolls; order by Tektronix Part No. 251-0514-00.

Observe the following precautions when soldering to ceramic terminal strips.

1. Use a hot iron for a short time. Apply only enough heat to make the solder flow freely.
2. Maintain a clean, properly tinned tip.
3. Avoid putting pressure on the ceramic terminal strip.
4. Do not attempt to fill the terminal-strip notch with solder; use only enough solder to cover the wires adequately.
5. Clean the flux from the terminal strip with a flux-remover solvent.

Metal Terminals. When soldering metal terminals (e.g., switch terminals, potentiometers, etc), ordinary 60/40 solder can be used. Use a soldering iron with a 40- to 75-watt rating and a $\frac{1}{8}$ -inch wide wedge-shaped tip.

Observe the following precautions when soldering metal terminals:

1. Apply only enough heat to make the solder flow freely.
2. Apply only enough solder to form a solid connection. Excess solder may impair the function of the part.
3. If a wire extends beyond the solder joint, clip off the excess.
4. Clean the flux from the solder joint with a flux-remover solvent.

Component Replacement

WARNING

Disconnect the instrument from the power source before replacing components.

Removing the Rear Panel. The rear panel must be removed for access to the rear subpanel. This panel can be removed by removing the Z Axis ground strap and the four screws located near the rear feet.

Swing-Out Chassis. Some of the controls and connectors are mounted on a swing-out chassis on the right side of this instrument. To reach the rear of this chassis or the components mounted behind it, first remove the top cover from the instrument. Then, loosen the captive securing screw so the chassis can swing outward.

Ceramic Terminal Strip Replacement. A complete ceramic terminal strip assembly is shown in Fig. 4-4. Replacement strips (including studs) and spacers are supplied under separate part numbers. However, the old spacers may be re-used if they are not damaged. The applicable Tektronix Part Numbers for the ceramic strips and spacers used in this instrument are given in the Mechanical Parts List.

To replace a ceramic terminal strip, use the following procedure:

REMOVAL:

1. Unsolder all components and connections on the strip. To aid in replacing the strip, it may be advisable to mark

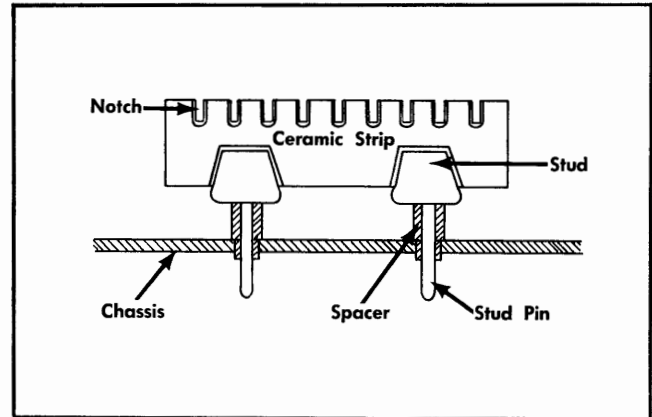

Fig. 4-4. Ceramic terminal strip assembly.

each lead or draw a sketch to show location of the components and connections.

2. Pry or pull the damaged strip from the chassis. Be careful not to damage the chassis.
3. If the spacers come out with the strip, remove them from the stud pins for use on the new strip (spacers should be replaced if they are damaged).

REPLACEMENT:

1. Place the spacers in the chassis holes.
2. Carefully press the studs of the strip into the spacers until they are completely seated. If necessary, use a soft mallet and tap lightly, directly over the stud, to seat the strip completely.
3. If the stud extends through the spacers, cut off the excess.
4. Replace all components and connections. Observe the soldering precautions given under Soldering Techniques in this section.

Circuit Board Replacement. If a circuit board is damaged beyond repair, either the entire assembly including all soldered-on components, or the board only, can be replaced. Part numbers are given in the Mechanical Parts List for either the completely wired or the unwired board. Most of the components mounted on the circuit boards can be replaced without removing the boards from the instrument. Observe the soldering precautions given under Soldering Techniques in this section. However, if the bottom side of the board must be reached or if the board must be moved to gain access to other areas of the instrument, only the mounting screws need to be removed. The interconnecting wires on most of the boards are long enough to allow the board to be moved out of the way or turned over without disconnecting the pin connectors.

GENERAL:

Most of the connections to the circuit boards are made with pin connectors. However, several connections are soldered between the attenuators and Vertical Preamp board. See the special removal instructions to remove these as a unit.

Use the following procedure to remove a circuit board.

Maintenance—Type 453/R453

1. Disconnect all pin connectors which come through holes in the board.
2. Remove all screws holding the board to the chassis.
3. The board may now be lifted for maintenance or access to areas beneath the board.
4. To completely remove the board, disconnect the remaining pin connectors.
5. Lift the circuit board out of the instrument. Do not force or bend the board.
6. To replace the board, reverse the order of removal. Correct location of the pin connectors is shown in Fig. 4-8 through 4-16. Replace the pin connectors carefully so they mate correctly with the pins. If forced into place incorrectly positioned, the pin connectors may be damaged.

VERTICAL PREAMP UNIT REMOVAL:

Use the following procedure to remove the Vertical Preamp board and the attenuators as a unit.

1. Remove the screw (mounted with a washer) which holds the MODE-TRIGGER switch (rear of board) to the chassis. The other screw may be left in place.
2. Remove the screw (with fiber washer) from the center of the board.
3. Unsolder the connections on the MODE-TRIGGER switch which do not go to the Vertical Preamp board.
4. Disconnect all pin connectors which lead off of the Vertical Preamp board.
5. Remove the attenuator shield and remove the nuts (four) located under this shield at each side of the INPUT connectors.
6. Remove the VARIABLE, CH 1 and CH 2 VOLTS/DIV, POSITION, Input Coupling, TRIGGER and MODE knobs.
7. Remove the securing nuts on the VOLTS/DIV switches and the STEP ATTEN BAL controls.
8. Remove the three screws at the rear of the board.
9. Lift up on the rear of the assembly and slide it out of the instrument.
10. The board may now be removed from the Vertical Preamp unit as follows:
 - a. Disconnect all pin connectors remaining on the board.
 - b. Unsolder all connections on the rear side of the board which connect between the attenuators and the board. Observe the soldering precautions given in this section.
 - c. Remove the remaining screw which holds the MODE-TRIGGER switch to the board.
 - d. Remove the four screws holding the board to the attenuators.
11. To replace the unit, reverse the order of removal. Be sure the GAIN and INVERT extensions are positioned correctly in the corresponding front-panel holes.

Cathode-Ray Tube Replacement. Use care when handling a CRT. Protective clothing and safety glasses should

be worn. Avoid striking it on any object which might cause it to crack or implode. When storing a CRT, place it face down on a smooth surface with a protective cover or soft mat under the faceplate to protect it from scratches.

The CRT shield should also be handled carefully. This shield protects the CRT display from distortion due to magnetic interference. If the shield is dropped or struck sharply, it may lose its shielding ability.

The following procedure outlines the removal and replacement of the cathode-ray tube:

A. REMOVAL:

1. Remove the top and bottom covers and rear panel as described previously.
2. Remove the light filter or faceplate protector.
3. Disconnect the CRT anode connector. Ground this lead and the anode connection to discharge any stored charge.
4. Unsolder the trace-rotation leads at the CRT shield.
5. Unsolder the y-axis rotation leads at the Y Axis Align control.
6. Disconnect the deflection-plate connectors. Be careful not to bend the deflection-plate pins.
7. Remove the CRT socket.
8. Remove the two nuts (by the graticule lights) which hold the front of the CRT shield to the subpanel.
9. Remove the graticule lights from the studs and position them away from the shield.
10. Loosen the two hex-head screws inside the rear of the CRT shield. Remove the shield angle clamps and mounting screws.
11. Slide the CRT assembly to the rear of the instrument until the faceplate clears the mounting studs. Then, lift the front of the CRT assembly up and slide it out of the instrument.
12. Loosen the three screws on the CRT clamp inside the CRT shield. Do not remove the screws.
13. Hold the left hand on the CRT faceplate and push forward on the CRT base with the right hand. As the CRT starts out of the shield, grasp it firmly with the left hand. When the CRT is free of the clamp, slide the shield completely off the CRT. Be careful not to bend the neck pins.

B. REPLACEMENT:

1. Insert the CRT into the shield. Be careful not to bend the neck pins. Seat the CRT firmly against the shield.
2. Tighten the bottom clamp screw—inside the CRT shield. Recommended tightening torque: 4 to 7 inch-lbs. Do not tighten the screws on the sides.
3. Place the light mask over the CRT faceplate.
4. Using a method similar to that for removal (step 11) re-insert the CRT assembly into the instrument. Be sure the CRT faceplate seats properly in the subpanel.
5. Tighten the two remaining screws on the inside of the CRT shield.

6. Replace the shield angle clamps and mounting screws on the rear subpanel. Tighten the two hex-head screws inside the rear of the CRT shield.

7. Replace the graticule lights and securing nuts.

8. Replace the CRT socket.

9. Reconnect the anode connector. Align the jack on the CRT and then plug in the connector and press firmly on the insulated cover to snap the plug into place.

10. Reconnect the trace-rotation and y-axis leads.

11. Reconnect the deflection-plate connectors. Correct location is indicated on the CRT shield.

12. Adjust the High Voltage, TRACE ROTATION, ASTIG, Y-Axis Align and Geometry adjustment. Adjustment procedure is given in the Calibration section. Also check the basic vertical and horizontal gain.

Transistor Replacement. Transistors should not be replaced unless actually defective. If removed from their sockets during routine maintenance, return them to their original sockets. Unnecessary replacement of transistors may affect the calibration of this instrument. When transistors are replaced, check the operation of that part of the instrument which may be affected.

CAUTION

POWER switch must be turned off before removing or replacing transistors.

Replacement transistors should be of the original type or a direct replacement. Fig. 4-2 shows the lead configuration of the transistors used in this instrument. Some plastic case transistors have lead configurations which do not agree with those shown here. If a transistor is replaced by a transistor which is made by a different manufacturer than the original, check the manufacturer's basing diagram for correct basing. All transistor sockets in this instrument are wired for the basing used for metal-case transistors. Transistors which have heat radiators or are mounted on the chassis use silicone grease to increase heat transfer. Replace the silicone grease when replacing these transistors.

WARNING

Handle silicone grease with care. Avoid getting silicone grease in the mouth or eyes. Wash hands thoroughly after use.

Two transistors in both the Channel 1 and Channel 2 Preamp circuit (Vertical Preamp circuit board) are permanently mounted in special temperature compensation blocks. These transistors (along with the temperature compensation block) must be replaced as a unit. When replacing the unit, place it so the reference information faces the left side of the instrument and the PNP transistor (labeled on side of unit) is toward the front of the instrument.

Fuse Replacement. Table 4-4 gives the rating, location, and function of the fuses used in this instrument.

Rotary Switches. Individual wafers or mechanical parts of rotary switches are normally not replaceable. If a switch is defective, replace the entire assembly. Replacement switch-

es can be ordered either wired or unwired; refer to the Parts List for the applicable part numbers.

When replacing a switch, tag the leads and switch terminals with corresponding identification tags as the leads are disconnected. Then, use the old switch as a guide for installing the new one. An alternative method is to draw a sketch of the switch layout and record the wire color at each terminal. When soldering to the new switch be careful that

TABLE 4-4
Fuse Ratings

Circuit Number	Rating	Location	Function
F937	2A Fast	Rear subpanel	High voltage
F1101	2A Fast	Line Voltage Selector assembly	115-volt line
F1102	1A Fast	Line Voltage Selector assembly	230-volt line
F1437	0.5A Fast	By power transformer	+75 volts
F1204	0.25A Fast	By power transformer	+150 volts

the solder does not flow beyond the rivets on the switch terminals. Spring tension of the switch contact can be destroyed by excessive solder.

The swing-out chassis on the right side of the instrument provides access to the side of the TIME/DIV and HORIZ DISPLAY switches. The top and bottom of these switches can be reached for easier repair or removal by removing the B Sweep board (top) or the A Sweep board (bottom).

Power Transformer Replacement. Be sure to replace only with a direct replacement Tektronix transformer.

When removing the transformer, tag the leads with the corresponding terminal numbers to aid in connecting the new transformer. After the transformer is replaced, check the performance of the complete instrument using the Performance Check procedure.

Power Chassis. The power transistors and other heat dissipating power-supply components are mounted below the Low-Voltage Regulator board. Remove the Low-Voltage Regulator board to reach these components. To reach the underside of the chassis, remove the fan through the rear subpanel.

High-Voltage Compartment. The components located in the high-voltage compartment can be reached for maintenance or replacement by using the following procedure.

1. Remove the bottom cover of the instrument as described in this section.
2. Remove the high-voltage shield.
3. Remove the three screws which hold the cover on the high-voltage compartment.

Maintenance—Type 453/R453

4. To remove the complete wiring assembly from the high-voltage compartment, unsolder the post-deflection anode lead (heavily insulated lead at side of compartment). The other leads are long enough to allow the assembly to be lifted out of the compartment to reach the parts on the under side.

5. To replace the high-voltage compartment, reverse the order of removal.

NOTE

All solder joints in the high-voltage compartment should have smooth surfaces. Any protrusions may cause high-voltage arcing at high altitudes.

Recalibration After Repair

After any electrical component has been replaced, the calibration of that particular circuit should be checked, as

well as the calibration of other closely related circuits. Since the low-voltage supply affects all circuits, calibration of the entire instrument should be checked if work has been done in the low-voltage supply or if the power transformer has been replaced. The Performance Check procedure in Section 5 provides a quick and convenient means of checking instrument operation.

Instrument Repackaging

If the Type 453 is to be shipped for long distances by commercial means of transportation, it is recommended that the instrument be repackaged in the original manner for maximum protection. The original shipping carton can be saved and used for this purpose. Fig. 4-5 illustrates how to repackage the Type 453 and gives the part number for the packaging components if new items are needed. Fig. 4-6 illustrates how to repackage the Type R453 and the applicable part numbers.

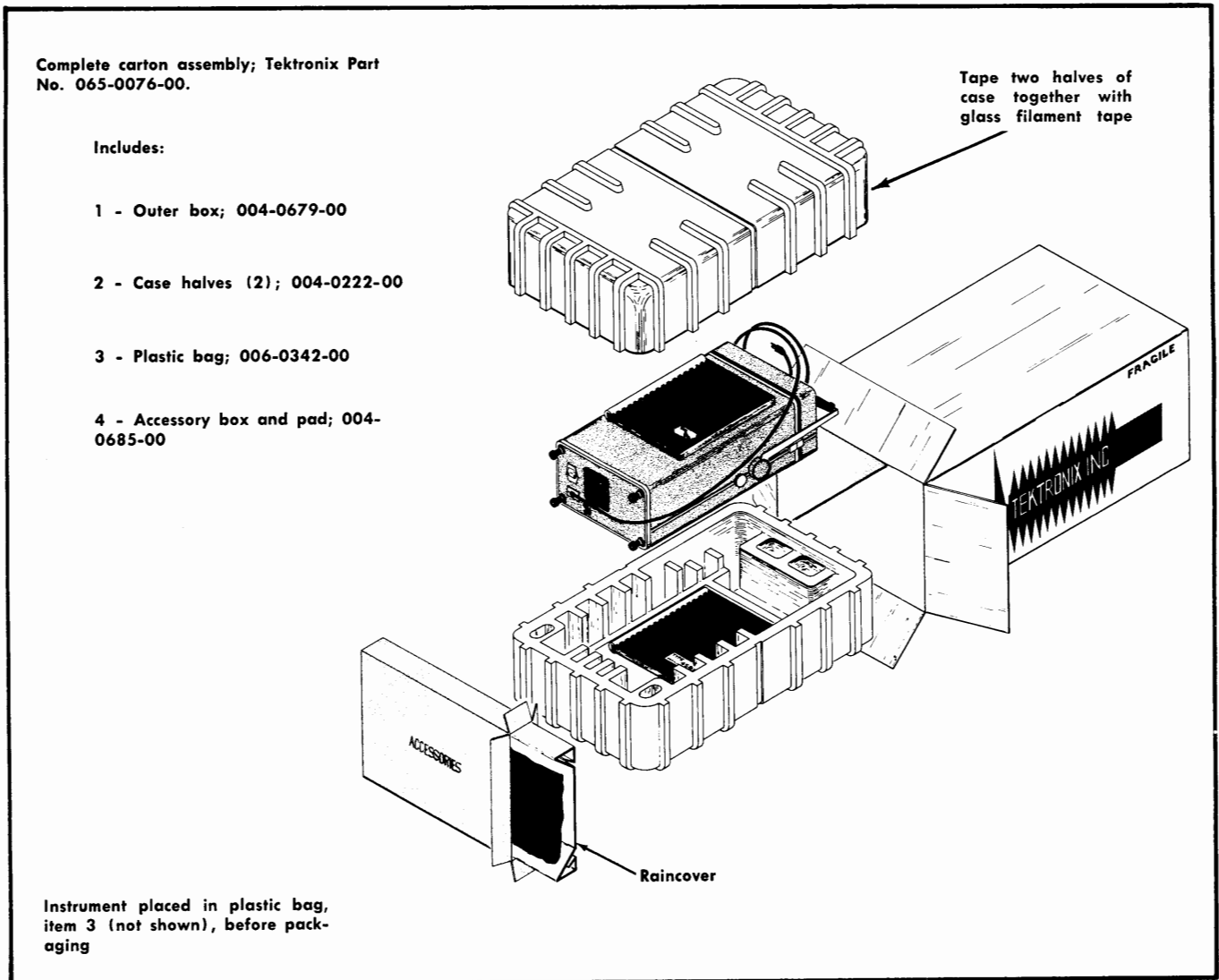

Fig. 4-5. Repackaging the Type 453 for shipment.

Complete carton assembly; Tektronix Part
No. 065-0101-00.

Includes:

- 1 - Inner box; 004-0460-00
- 2 - Inner pad set; 004-0359-00
- 3 - Side pad set; 004-0360-00
- 4 - Bottom pad; 004-0357-00
- 5 - Rear pad (2); 004-0556-00
- 6 - Outer box; 004-0461-00
- 7 - Accessories box; 004-0462-00
- 8 - Outer pad set; 004-0361-00

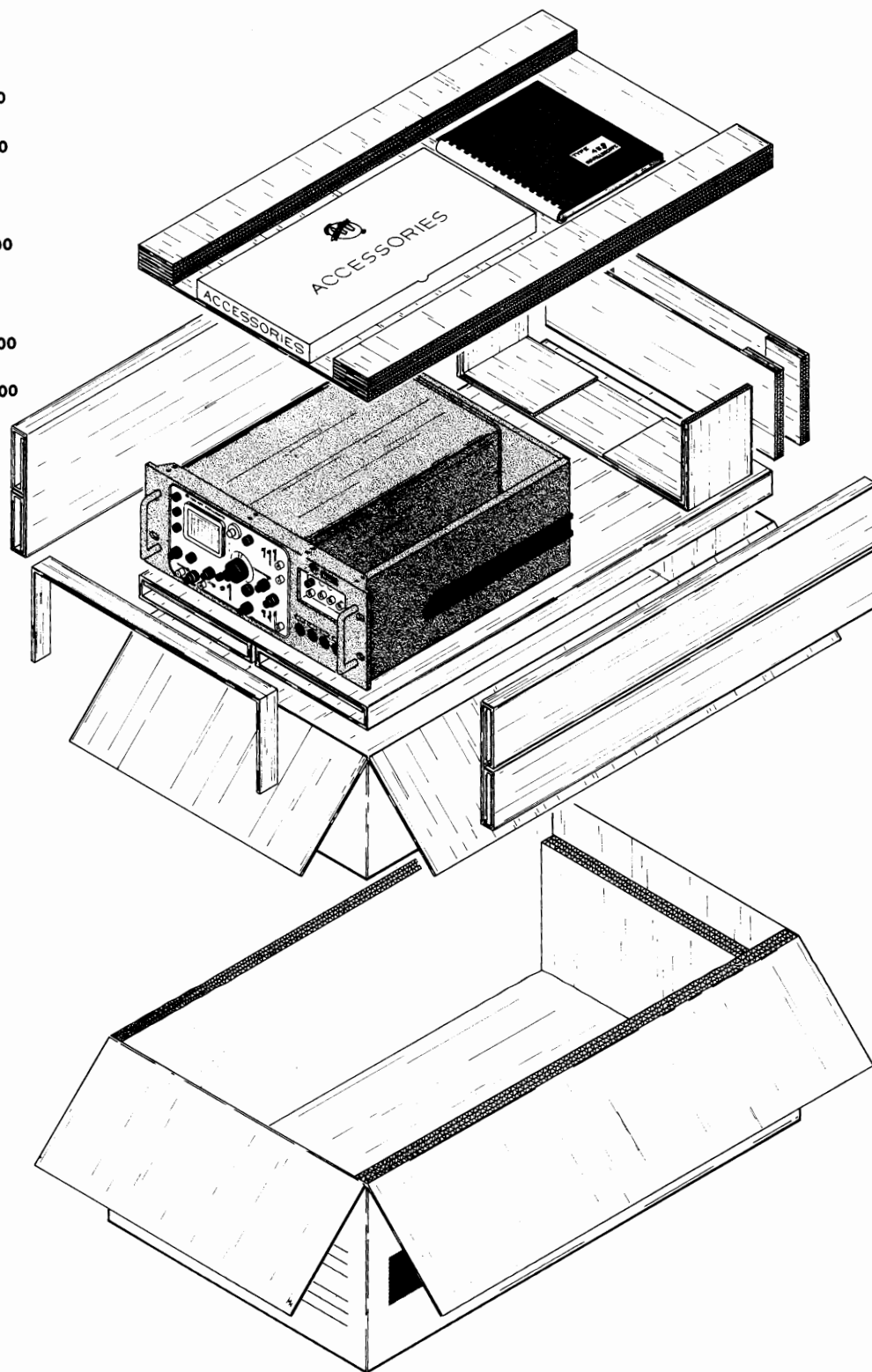

Fig. 4-6. Repackaging the Type R453 for shipment.

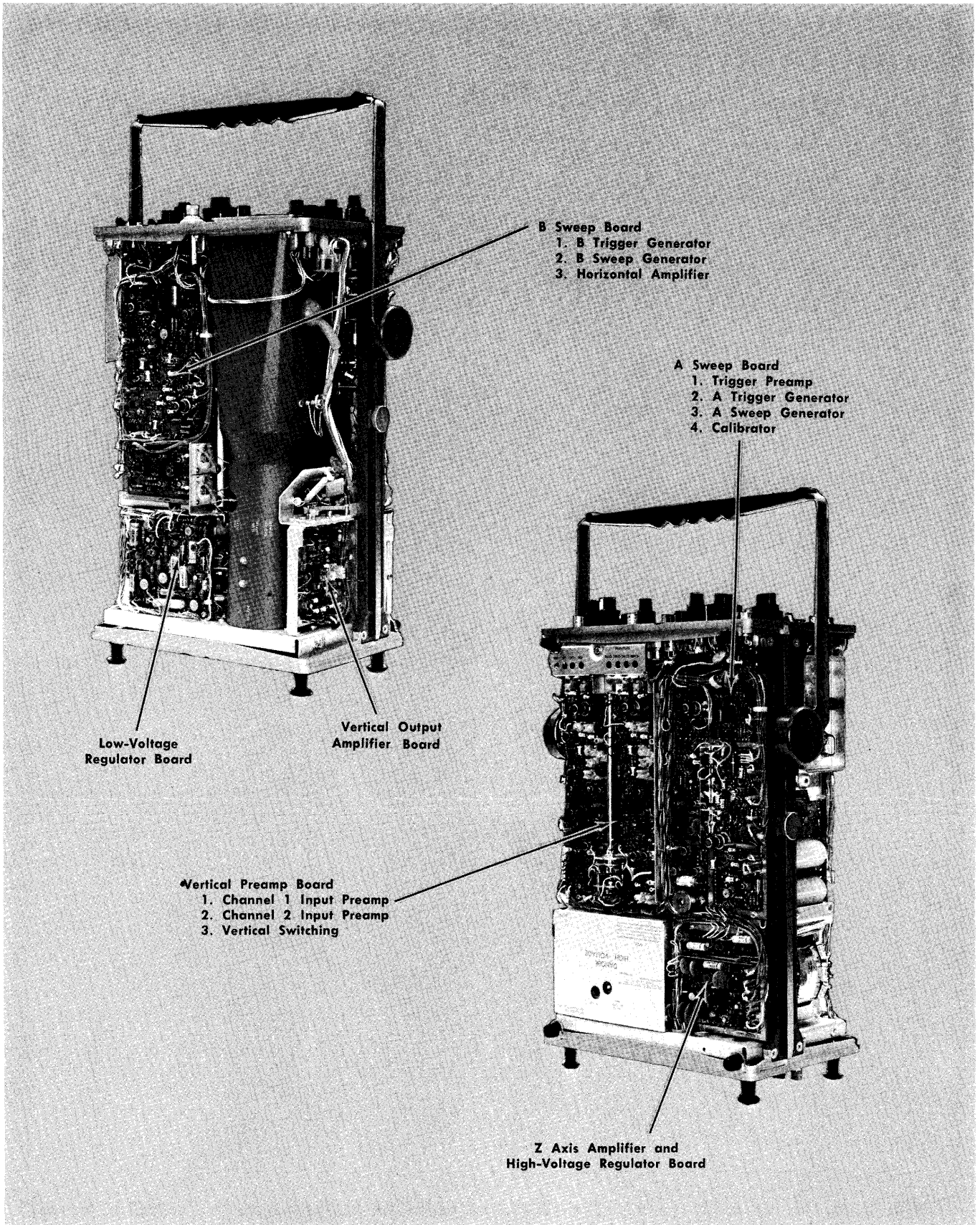
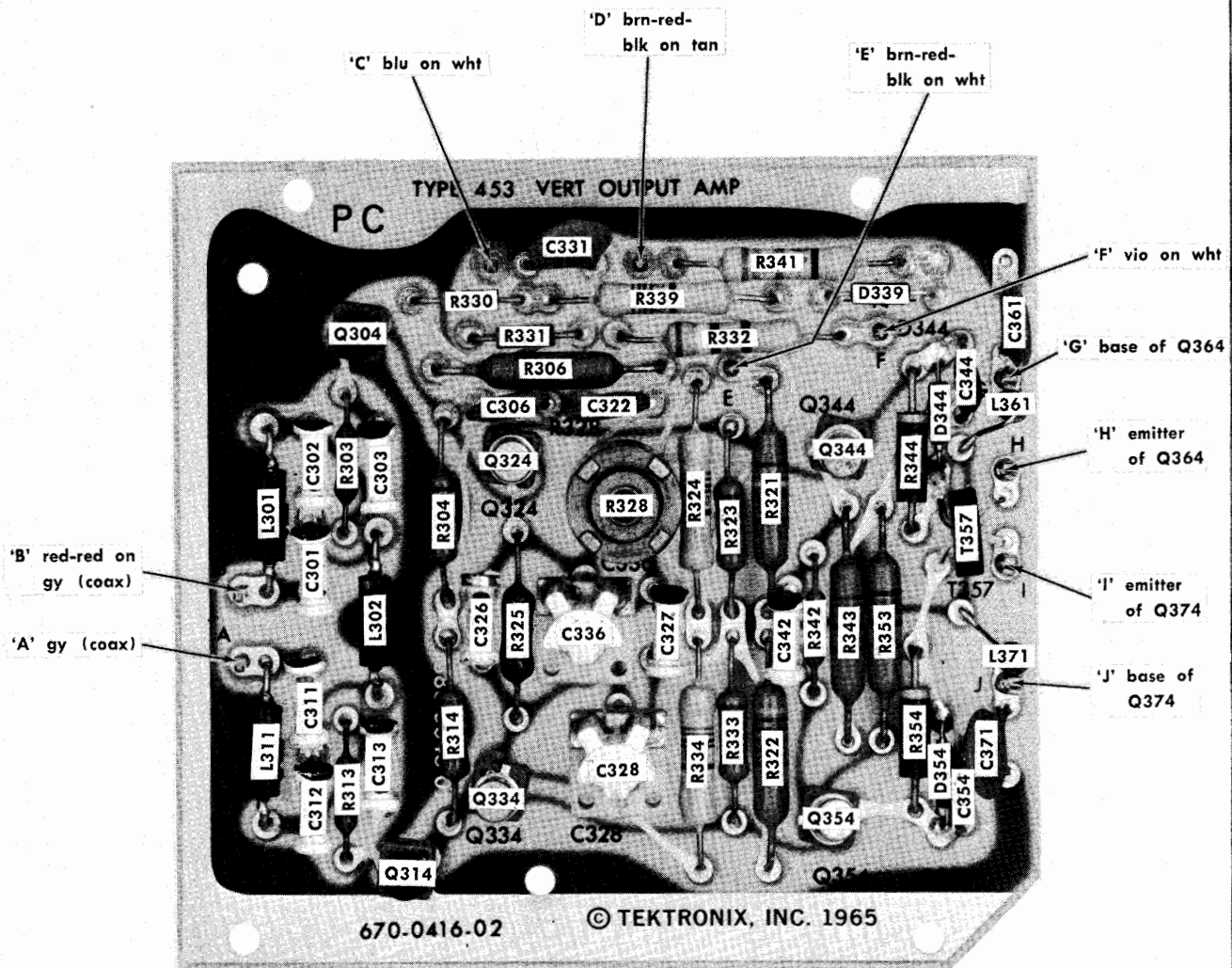

Fig. 4-7. Location of circuit boards in Type 453.



NOTE:

C340, C347, R340, R347, R348 mounted on rear of board.



Fig. 4-8. Vertical Output Amplifier circuit board.

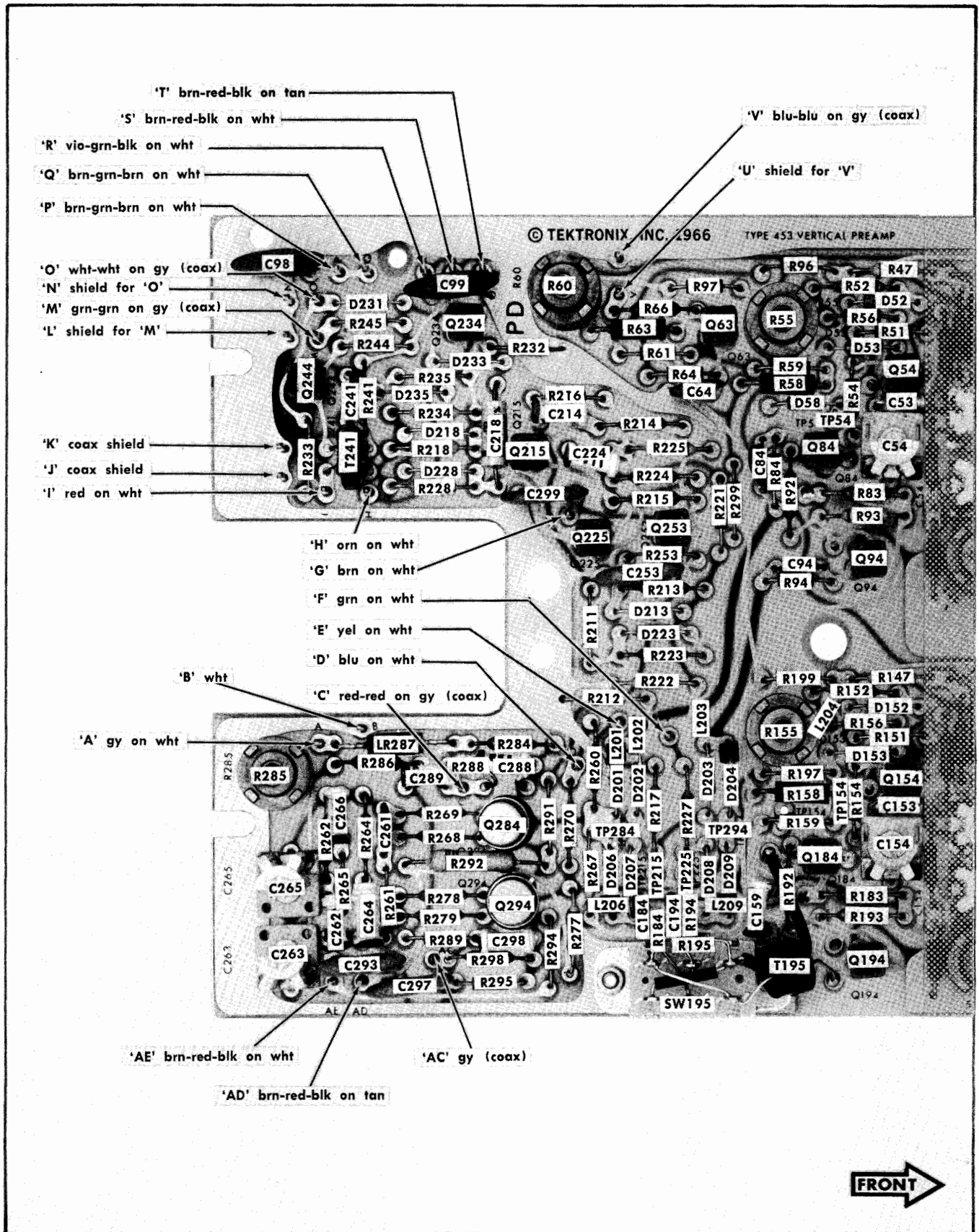

Fig. 4-9. Partial Vertical Preamp circuit board. Vertical Switching and partial Vertical Preamp circuit shown.

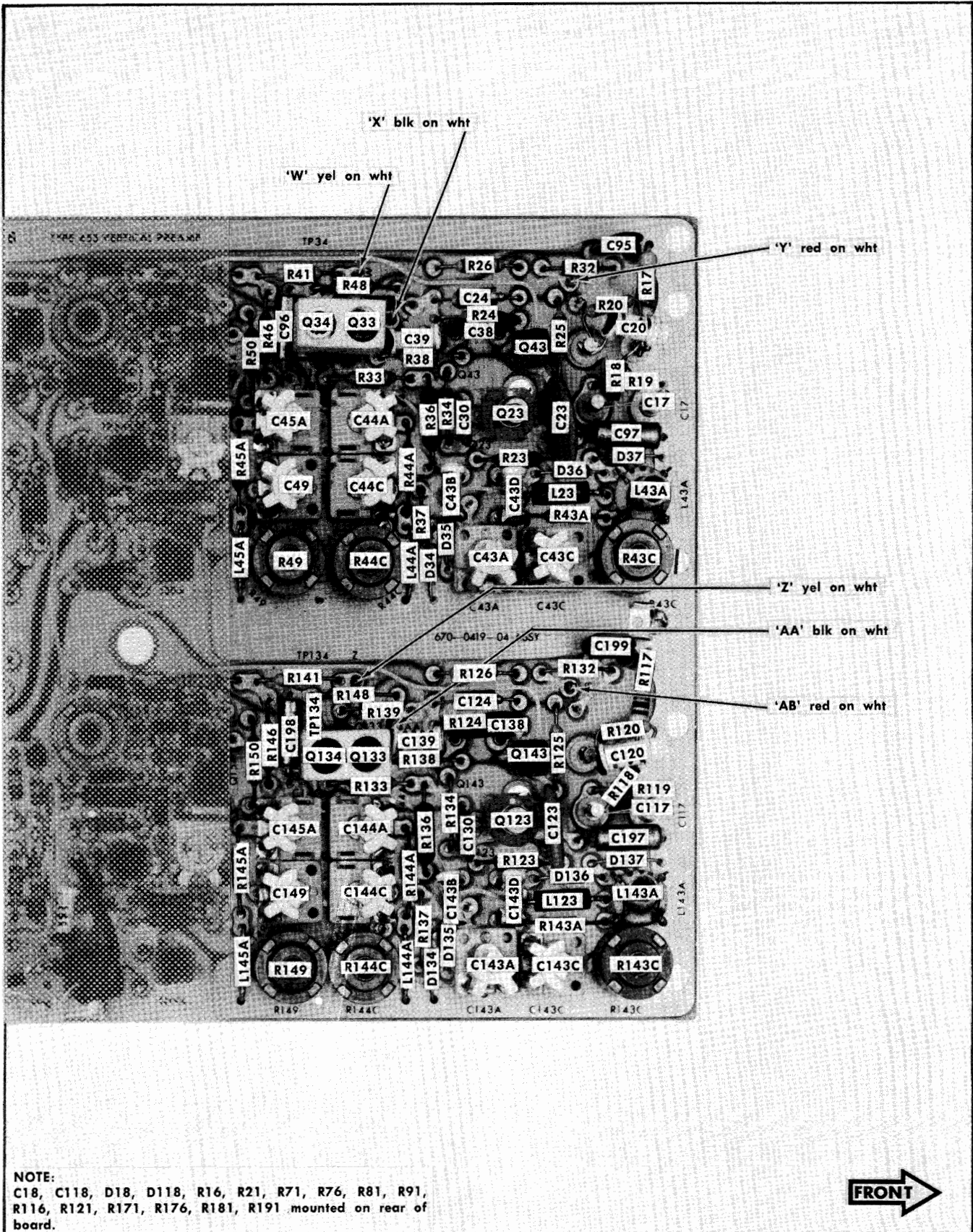

Fig. 4-10. Partial Vertical Preamp circuit board. Partial Vertical Preamp circuit shown.

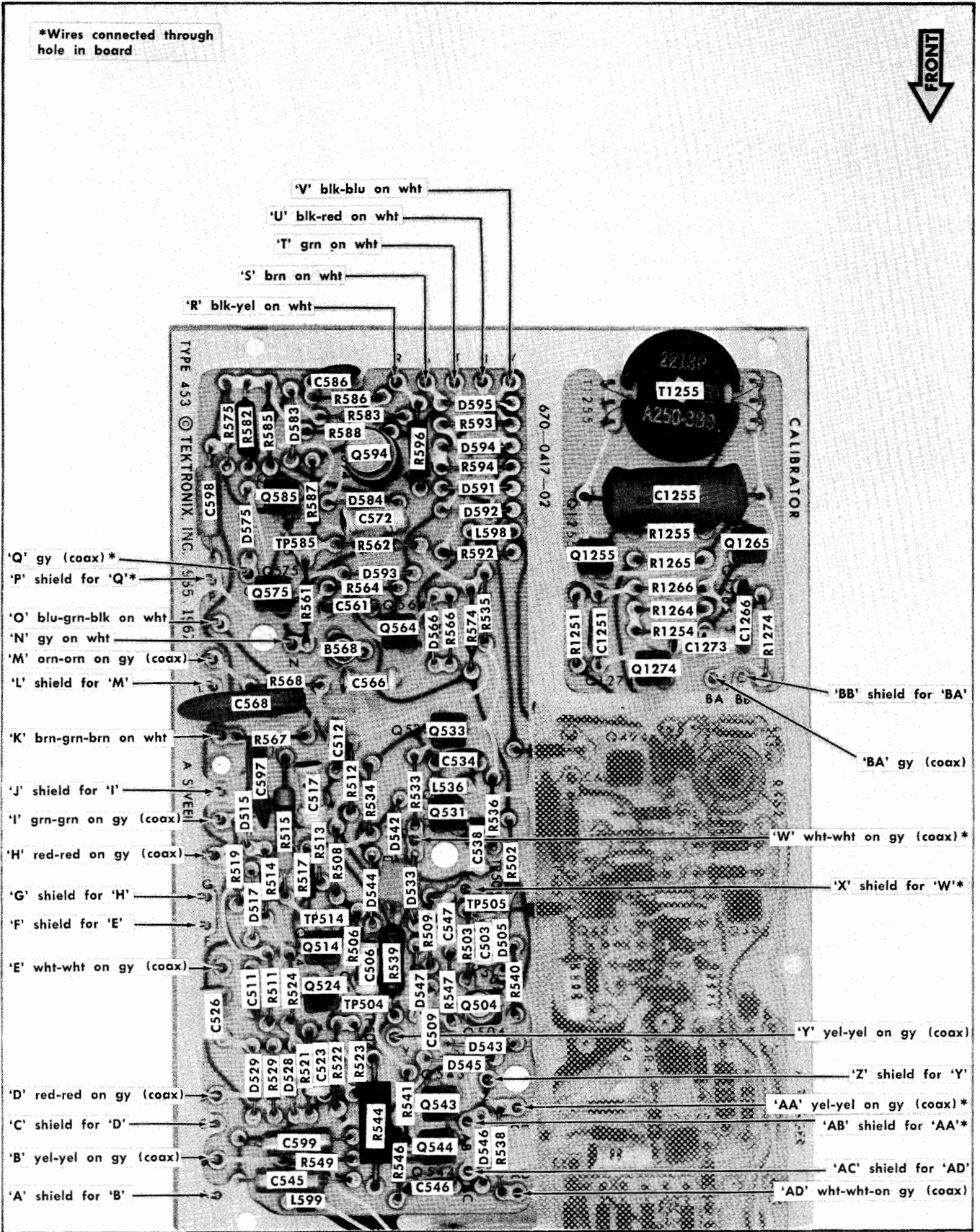

Fig. 4-11. Partial A Sweep circuit board. A Sweep Generator and Calibrator circuits shown.

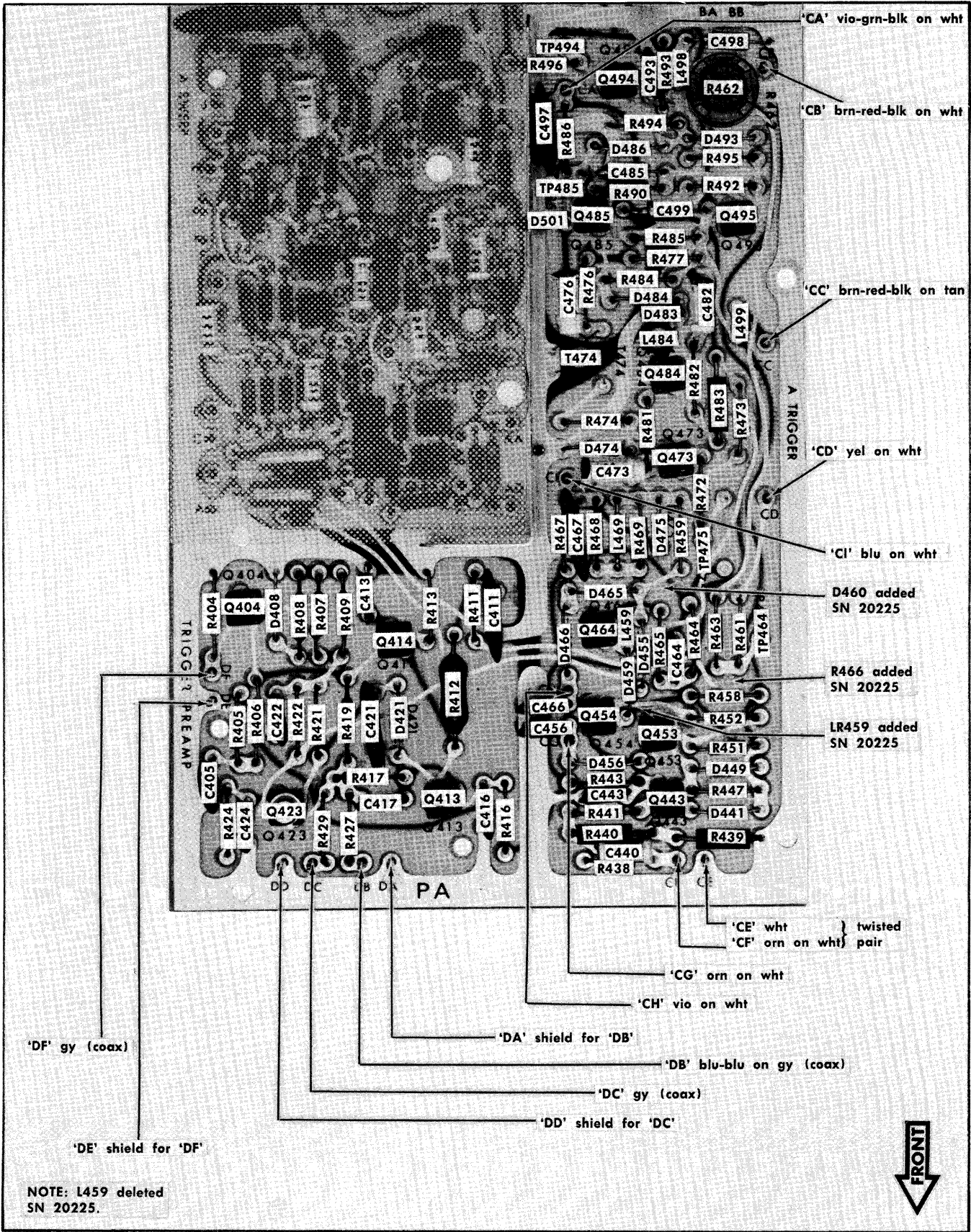

Fig. 4-12. Partial A Sweep circuit board. Trigger Preamp and A Trigger Generator circuits shown.

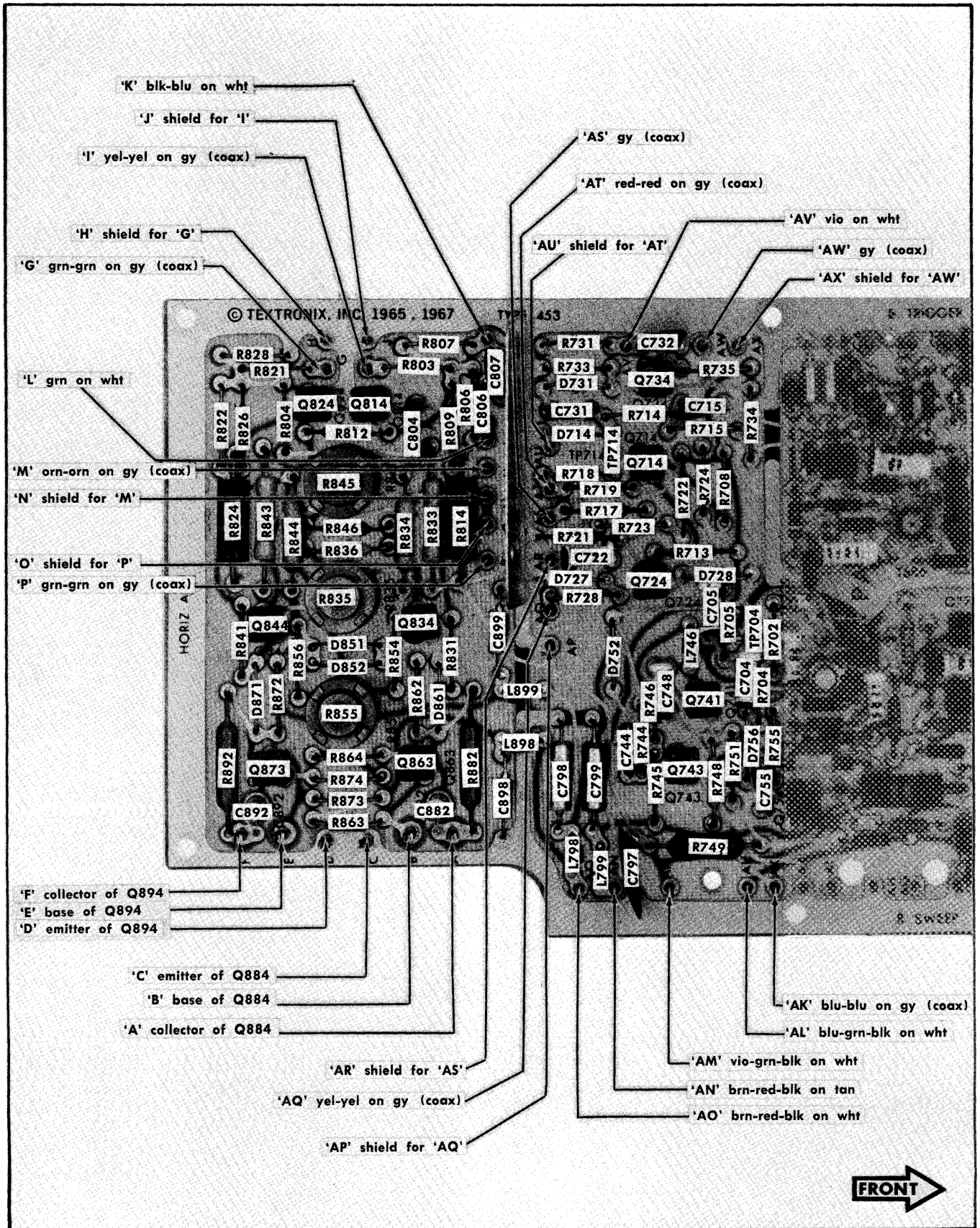

Fig. 4-13. Partial B Sweep circuit board. Horizontal Amplifier and partial B Sweep Generator circuits shown.

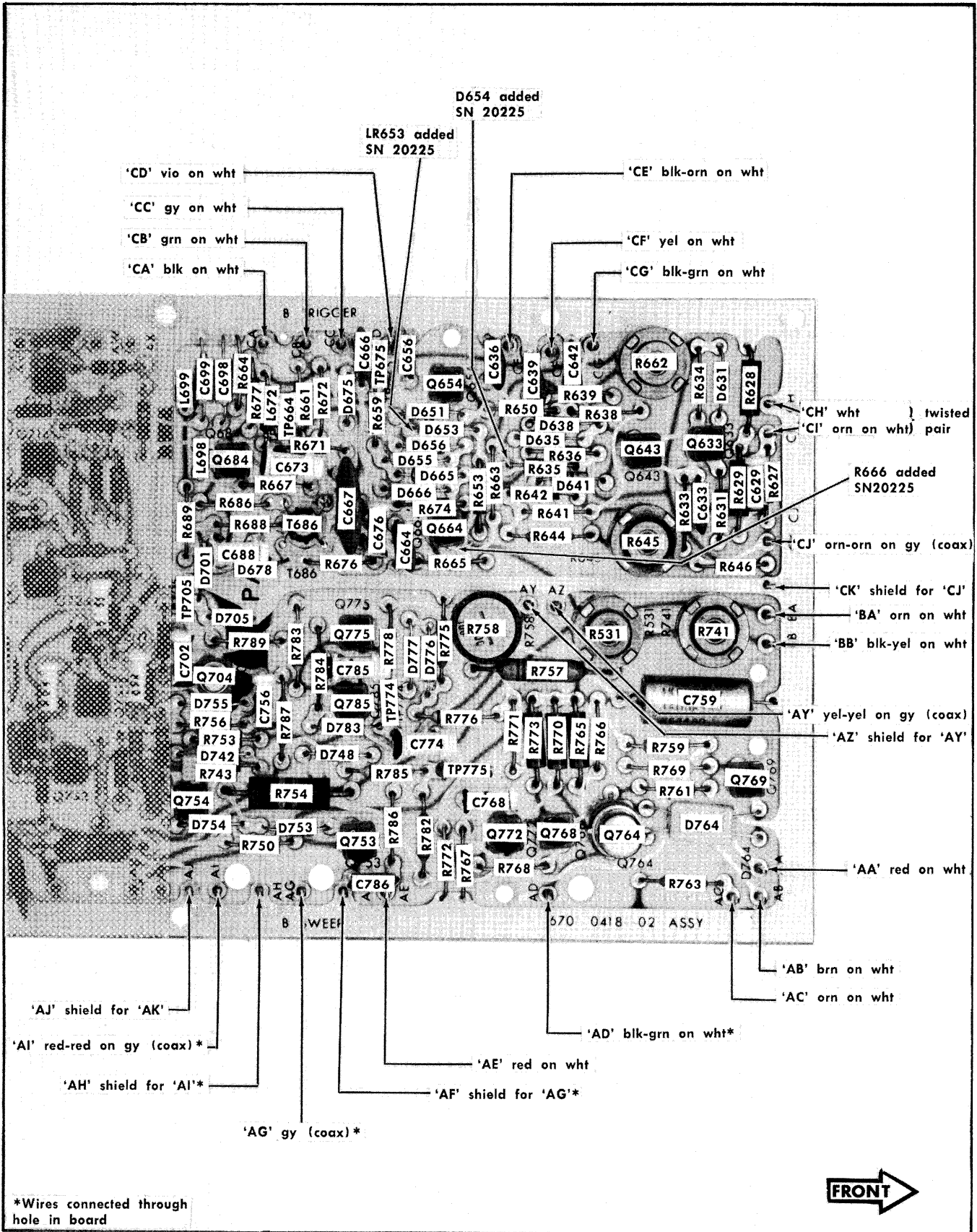

Fig. 4-14. Partial B Sweep circuit board. B Trigger Generator and B Sweep Generator circuits shown.

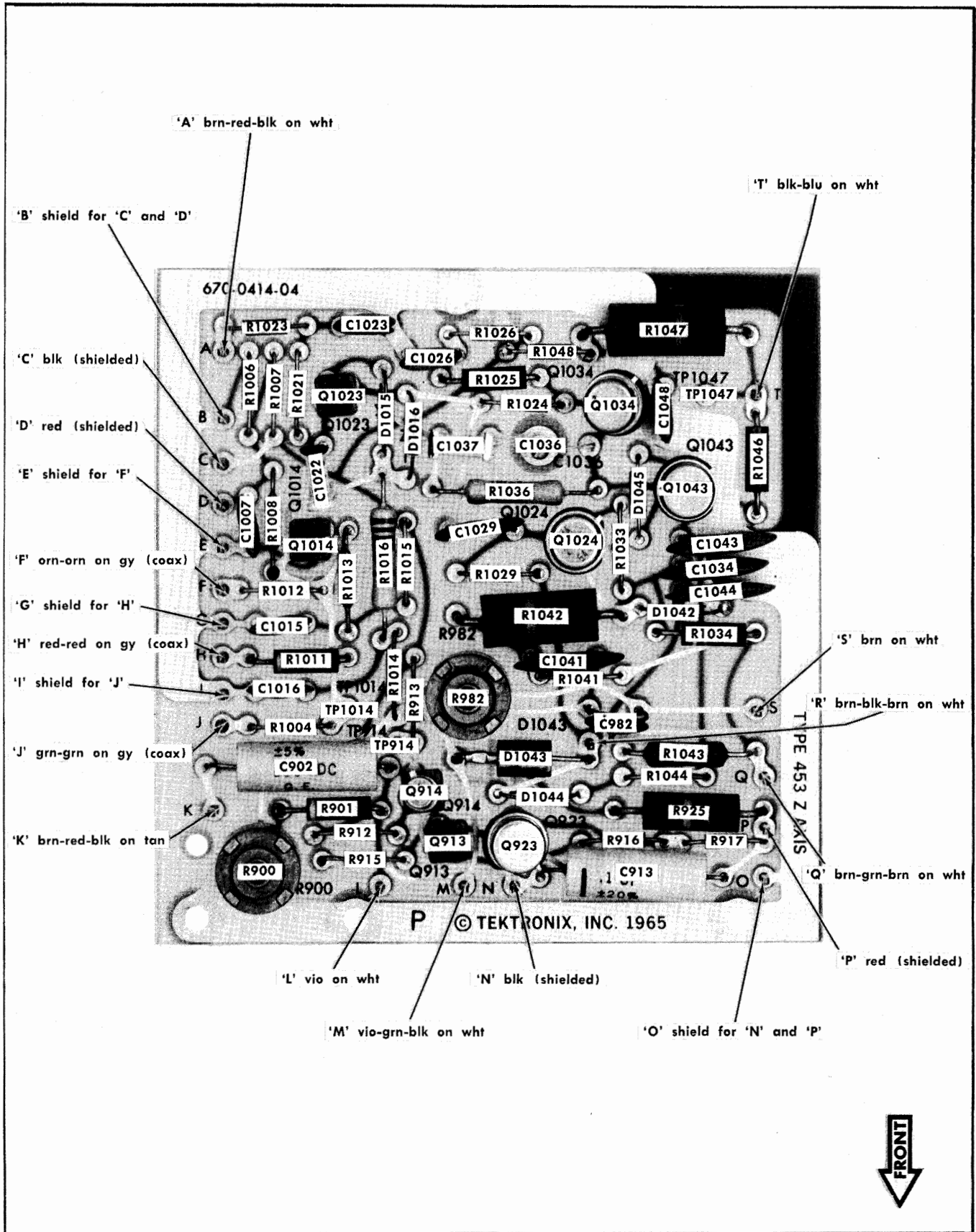

Fig. 4-15. Z Axis Amplifier and High-Voltage Regulator circuit board.

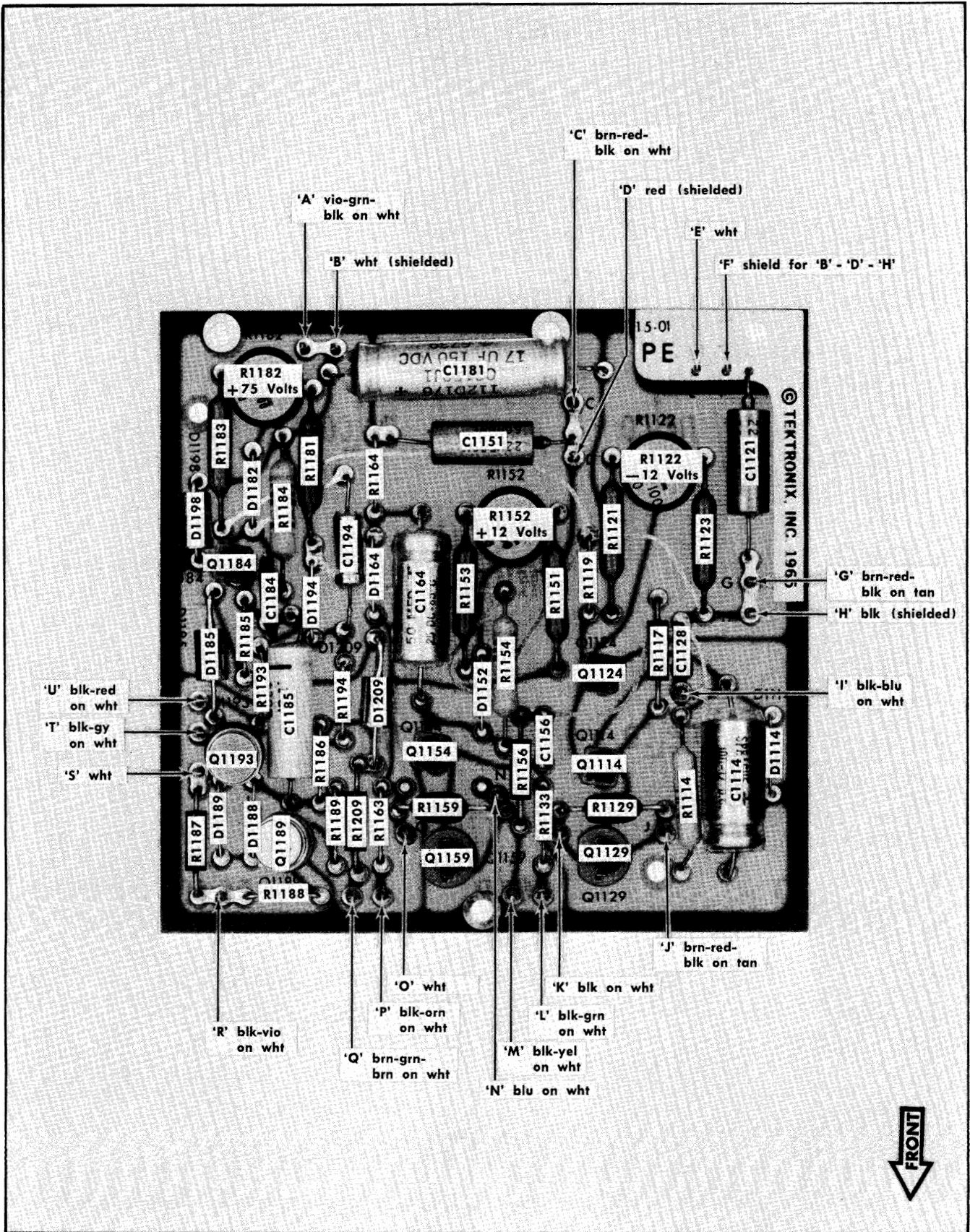

Fig. 4-16. Low Voltage Regulator circuit board.

SECTION 5

PERFORMANCE CHECK / CALIBRATION

Change information, if any, affecting this section will be found at the rear of the manual.

Introduction

To assure instrument accuracy, check the calibration of the Type 453 every 1000 hours of operation, or every six months if used infrequently. Before complete calibration, thoroughly clean and inspect this instrument as outlined in the Maintenance section.

As an aid to the calibration of the instrument, a Short-Form Procedure is given prior to the complete procedure. To facilitate instrument calibration for the experienced calibrator, the Short-Form Procedure lists the calibration adjustments necessary for each step and the applicable tolerances. This procedure also includes the step number and title as listed in the complete Performance Check/Calibration Procedure and the page number on which each step begins. Therefore, the Short-Form Procedure can be used as an index to locate a step in the complete procedure. Another feature of the Short-Form Procedure is the spaces provided to record performance data or to check off steps as they are completed. This procedure can be reproduced and used as a permanent record of instrument calibration.

The complete Performance Check/Calibration Procedure can be used to check instrument performance without removing the covers or making internal adjustments by performing all portions except the ADJUST— part of a step. Screwdriver adjustments which are accessible without removing the covers are adjusted as part of the performance check procedure. A note titled PERFORMANCE CHECK ONLY gives instructions which are applicable only to the performance check procedure and if necessary, lists the next applicable step for the performance check procedure.

Completion of each step in the complete Performance Check/Calibration Procedure insures that this instrument meets the electrical specifications given in Section 1. Where possible, instrument performance is checked before an adjustment is made. For best overall instrument performance when performing a complete calibration procedure, make each adjustment to the exact setting even if the CHECK— is within the allowable tolerance.

NOTE

All waveforms shown in this procedure were taken with a Tektronix Oscilloscope Camera System. Limits, tolerances and waveforms in this procedure are given as calibration guides and should not be interpreted as instrument specifications except as specified in Section 1.

A partial calibration is often desirable after replacing components, or to touch up the adjustment of a portion of the instrument between major recalibrations. To check or adjust only part of the instrument, set the controls as given under Preliminary Control Settings and start with the nearest test equipment picture preceding the desired portion. If any controls need to be changed from the preliminary settings for this portion of the calibration procedure, they are listed under the heading Partial Procedure following the equipment required picture. To prevent unnecessary recalibration of other parts of the instrument, readjust only if the tolerance given in the CHECK— part of this step is not met. If readjustment is necessary, also check the calibration of any steps listed in the INTERACTION—part of the step.

TEST EQUIPMENT REQUIRED

General

The following test equipment, or its equivalent, is required for complete calibration of the Type 453. Specifications given are the minimum necessary for accurate calibration of this instrument. All test equipment is assumed to be correctly calibrated and operating within the given specifications. If equipment is substituted, it must meet or exceed the specifications of the recommended equipment.

Special Tektronix calibration fixtures are used in this procedure only where they facilitate calibration. These special calibration fixtures are available from Tektronix, Inc. Order by part number through your local Tektronix Field Office or representative.

1. Variable autotransformer.¹ Must be capable of supplying 200 volt-amperes over a range of 90 to 137 volts (180 to 274 volts for 230-volt nominal line). (If autotransformer does not have an AC voltmeter to indicate output voltage, monitor the output with an AC voltmeter with a range of at least 137 or 274 volts, RMS.) For example, General Radio W10MT3W Metered Variac Autotransformer (note that the full current capabilities of this unit are not required).

2. Precision DC voltmeter.¹ Accuracy, within $\pm 0.05\%$; meter resolution, 50 microvolts; range, zero to two kilovolts. For example, Fluke Model 825A Differential DC Voltmeter (use Fluke Model 80E-2 Voltage divider to measure voltages above 500 volts).

¹Not required for performance check only.

Performance Check/Calibration—Type 453/R453

3. Test Oscilloscope. Bandwidth, DC to 50 megahertz; minimum deflection factor, five millivolts/division; accuracy, within 3%. Tektronix Type 453 Oscilloscope recommended.

4. $1\times$ Probe with BNC connector.¹ Tektronix P6011 Probe recommended.

5. $10\times$ Probe with BNC connector. Tektronix P6010 Probe recommended.

6. Time-mark generator. Marker outputs, five seconds to 10 nanoseconds; marker accuracy, within 0.1%. Tektronix Type 184 Time-Mark Generator recommended.

7. Standard amplitude calibrator. Amplitude accuracy, within 0.25%; signal amplitude, five millivolts to 50 volts; output signal, one-kilohertz square wave and positive DC voltage. Tektronix calibration fixture 067-0502-00 recommended.

8. Square-wave generator. Frequency, one and 100 kilohertz; risetime, 12 nanoseconds or less from high-amplitude output and one nanosecond or less from fast-rise output (into 50 ohms); output amplitude, about 120 volts unterminated or 12 volts into 50 ohms from high-amplitude output—50 to 500 millivolts into 50 ohms from fast-rise output. Tektronix Type 106 Square-Wave Generator recommended.

9. Constant-amplitude sine-wave generator. Frequency, 350 kilohertz to above 50 megahertz; reference frequency, 50 kilohertz; output amplitude, variable from five millivolts to five volts into 50 ohms or 10 volts unterminated; amplitude accuracy, within 3% at 50 kilohertz and from 350 kilohertz to above 50 megahertz. Tektronix Type 191 Constant Amplitude Signal Generator recommended.

10. Low-frequency sine-wave generator. Frequency, 60 hertz to one megahertz; output amplitude, variable from 0.5 volts to 40 volts peak to peak; amplitude accuracy, within 3% from 60 hertz to one megahertz. For example, General Radio 1310-A Oscillator (use a General Radio Type 274 QBJ Adapter to provide BNC output).

11. Current-measuring probe with passive termination. Sensitivity, two milliamperes/millivolt; accuracy, within 3%. Tektronix P6021 Current Probe with 011-0105-00 passive termination recommended.

12. Cable (two). Impedance, 50 ohms; type, RG-58/U; length, 42 inches; connectors, BNC. Tektronix Part No. 012-0057-01.

13. BNC T connector. Tektronix Part No. 103-0030-00.

14. Cable. Impedance, 50 ohms; type, RG-58/U; length, 18 inches; connectors, BNC. Tektronix Part No. 012-0076-00.

15. Cable. Impedance, 50 ohms; type, RG-213/U; electrical length, five nanoseconds; connectors, GR874. Tektronix Part No. 017-0502-00.

16. In line termination. Impedance, 50 ohms; wattage rating, two watts; accuracy, $\pm 3\%$; connectors, GR874 input with BNC male output. Tektronix Part No. 017-0083-00.

17. Input RC normalizer. Time constant, 1 megohm \times 20 picofarads; attenuation, $2\times$; connectors, BNC. Tektronix calibration fixture 067-0538-00.

18. $5\times$ attenuator. Impedance, 50 ohms; accuracy, $\pm 3\%$; connectors, GR874. Tektronix Part No. 017-0079-00.

19. Dual-input coupler. Matched signal transfer to each input. Tektronix calibration fixture 067-0525-00.

20. Adapter. Adapts GR874 connector to BNC female connector. Tektronix Part No. 017-0064-00.

21. Termination. Impedance, 50 ohms; accuracy, $\pm 3\%$; connectors, BNC. Tektronix Part No. 011-0049-00.

22. Adapter. Connectors, BNC female and two alligator clips. Tektronix Part No. 013-0076-00.

23. Screwdriver. Three-inch shaft, $\frac{3}{32}$ -inch bit for slotted screws. Tektronix Part No. 003-0192-00.

24. Low-capacitance screwdriver.¹ $1\frac{1}{2}$ -inch shaft. Tektronix Part No. 003-0000-00.

25. Tuning rod.¹ Five-inch, for 0.100-inch (ID) hex slugs. Tektronix Part No. 003-0301-00.

26. Tuning tool.¹ Handle and insert for $\frac{5}{64}$ -inch (ID) hex cores. Tektronix Part No. 003-0307-00 and 033-0310-00.

SHORT-FORM CALIBRATION PROCEDURE

Type 453, Serial No. _____

Calibration Date _____

Calibrated by _____

1. Adjust -12 -Volt Power Supply (R1122) Page 5-8
 REQUIREMENT: -12 volts ± 0.032 volt.
 PERFORMANCE: -12 volts \pm _____ volt.

2. Adjust $+12$ -Volt Power Supply (R1152) Page 5-8
 REQUIREMENT: $+1$ volt, ± 0.01 volt, at 1 kHz CAL connector with Q1255 removed. $+12.1$ volts, ± 0.2 volt, output from supply.
 PERFORMANCE: $+1$ volt, \pm _____ volt, at 1 kHz CAL connector with Q1255 removed. $+12.1$ volts, \pm _____ volt, output from supply.

3. Adjust $+75$ -Volt Power Supply (R1182) Page 5-9
 REQUIREMENT: $+75$ volts ± 0.278 volt.
 PERFORMANCE: $+75$ volts \pm _____ volt.

4. Adjust High-Voltage Supply and Check Page 5-9
 Regulation (R900).
 REQUIREMENT: -1950 volts ± 58.5 volts. Remains within 58.5 volts of level over input line voltage range and INTENSITY control changes.
 PERFORMANCE: -1950 volts \pm _____ volts. Remains within _____ volts of level over input line voltage range and INTENSITY control changes.

5. Adjust CRT Grid Bias (R940). Page 5-10
 REQUIREMENT: Adjust CRT grid bias; see complete procedure.

6. Check Low-Voltage Power Supply Ripple Page 5-10

SUPPLY	REQUIREMENT	PERFORMANCE
-12 volt	2 millivolts	_____
$+12$ volt	2 millivolts	_____
$+75$ volt	2 millivolts	_____

Performance Check/Calibration—Type 453/R453

- 7. Adjust Trace Alignment (R980) Page 5-10
 REQUIREMENT: Trace parallel to center horizontal line within 0.1 division/10 divisions.
 PERFORMANCE: Within _____ division.
- 8. Adjust Astigmatism (R985). Page 5-10
 REQUIREMENT: Sharp, well-defined display; see complete procedure.
- 9. Adjust Y Axis Alignment (R989). Page 5-11
 REQUIREMENT: Markers parallel to the center vertical line; see complete procedure.
- 10. Adjust CRT Geometry (R982) Page 5-11
 REQUIREMENT: Deviation from straight line should not exceed 0.1 division.
 PERFORMANCE: Within _____ division.
- 11. Adjust Channel 1 and 2 Step Attenuator Page 5-11
 Balance (R30, R130).
 REQUIREMENT: No trace shift as CH 1 or CH 2 VOLTS/DIV switch is changed from 20 mV to 5 mV.
 PERFORMANCE: Channel 1 step attenuator balance, _____ division shift; Channel 2 step attenuator balance, _____ division shift.
- 12. Adjust Channel 1 and 2 Position Center Page 5-12
 (R55, R155).
 REQUIREMENT: Trace at center horizontal line with Channel 1 and 2 POSITION controls centered; see complete procedure.
 PERFORMANCE: Channel 1 trace within _____ division; Channel 2 trace within _____ division.
- 13. Adjust Channel 1 and 2 Gain (R90, R190). Page 5-13
 REQUIREMENT: Five divisions vertical deflection at 20 mV/DIV with 0.1 volt square-wave input.
 PERFORMANCE: Five division \pm _____ division.
- 14. Check Added Mode Operation. Page 5-14
 REQUIREMENT: Correct signal addition, $\pm 1\%$.
 PERFORMANCE: Correct _____; incorrect _____.
- 15. Check Channel 1 and 2 Deflection Page 5-14
 Accuracy.
 REQUIREMENT: Vertical deflection within 3% of CH 1 and CH 2 VOLTS/DIV switch indication.
 PERFORMANCE: Correct _____; incorrect (list exceptions) _____.
- 16. Check Channel 1 and 2 Variable Page 5-15
 Volts/Division Range.
 REQUIREMENT: Variable attenuation ratio of at least 2.5:1.
 PERFORMANCE: Correct _____; incorrect _____.
- 17. Check Channel 1 and 2 Cascaded Page 5-15
 Deflection Factor.
 REQUIREMENT: One millivolt/division or less.
 PERFORMANCE: _____ millivolt/division.
- 18. Check Channel 1 and 2 Input Coupling Page 5-16
 Switch Operation.

REQUIREMENT: Correct signal coupling in each position of the Channel 1 and 2 Input Coupling switches.
 PERFORMANCE: Correct _____; incorrect _____.

- 19. Check Low-Frequency Vertical Linearity. Page 5-16
 REQUIREMENT: 0.15 division, or less compression or expansion of a two-division signal (at center screen) when positioned to the vertical extremes of the graticule area.
 PERFORMANCE: _____ division.
- 20. Check Trace Shift Due to Input Gate Page 5-17
 Current.
 REQUIREMENT: Negligible at 5 mV VOLTS/DIV as Channel 1 and 2 Input Coupling switches are changed from GND to DC.
 PERFORMANCE: Correct _____; incorrect _____.
- 21. Check Alternate Operation Page 5-17
 REQUIREMENT: Trace alternation at all sweep rates.
 PERFORMANCE: Correct _____; incorrect _____.
- 22. Adjust Channel 1 Volts/Division Switch Page 5-17
 Compensation (C6B, C6C, C7B, C7C, C8B, C8C, C9B, C9C, C11, C17).
 REQUIREMENT: Optimum square corner and flat top within 1% at each position of the Channel 1 VOLTS/DIV switch between 50 mV/DIV and 10 V/DIV.
 PERFORMANCE: Correct _____; incorrect (list exceptions) _____.
- 23. Adjust Channel 2 Volts/Division Switch Page 5-18
 Compensation (C106B, C106C, C107B, C107C, C108B, C108C, C109B, C109C, C111, C117).
 REQUIREMENT: Optimum square corner and flat top within 1% at each position of the Channel 2 VOLTS/DIV switch between 50 mV/DIV and 10 V/DIV.
 PERFORMANCE: Correct _____; incorrect (list exceptions) _____.
- 24. Adjust High-Frequency Compensation Page 5-19
 (C43A, C43C, C44A, C44C, C45A, C49, C54, C143A, C143C, C144A, C144C, C145A, C149, C154, C263, C265, C328, C336, L43A, L143A, R43C, R49, R44C, R143C, R144C, R149, R328).

SENSITIVITY	REQUIREMENT	PERFORMANCE
5 mV/DIV	Less than 2% peak to peak	_____
10 mV/DIV	Less than 2% peak to peak	_____
20 mV/DIV	Less than 2% peak to peak	_____
50 mV/DIV to 2 V/DIV	Less than 3% peak to peak	_____
5 V/DIV to 10 V/DIV	Less than 6% peak to peak	_____
ADDED mode 20 mV/DIV	Less than 6% peak to peak	_____
- 25. Check Upper Vertical Bandwidth Limit Page 5-21
 of Channel 1 and 2.

Performance Check/Calibration—Type 453/R453

SENSITIVITY	REQUIREMENT	PERFORMANCE
20 mV/DIV	—3 dB at 50 megahertz or higher	_____
10 mV/DIV	—3 dB at 45 megahertz or higher	_____
5 mV/DIV	—3 dB at 40 megahertz or higher	_____

- 26. Check Upper Added Mode Bandwidth Limit. Page 5-22
 REQUIREMENT: Not more than —3 dB at 50 megahertz.
 PERFORMANCE: _____ megahertz.
- 27. Check Upper Channel 1 and 2 Cascaded Bandwidth Limit. Page 5-23
 REQUIREMENT: Not more than —3 dB at 25 megahertz.
 PERFORMANCE: _____ megahertz.
- 28. Check Common-Mode Rejection Ratio. Page 5-23
 REQUIREMENT: 20:1 or greater at 20 megahertz.
 PERFORMANCE: Correct _____; incorrect _____.
- 29. Check Attenuator Isolation Ratio. Page 5-23
 REQUIREMENT: 10,000:1 or greater at 20 megahertz.
 PERFORMANCE: Correct _____; incorrect _____.
- 30. Adjust A and B Trigger Level Centering (R462, R662). Page 5-24
 REQUIREMENT: Correct operation of trigger circuits; see complete procedure.
 PERFORMANCE: Correct _____; incorrect _____.
- 31. Adjust Channel 1 Trigger DC Level and Normal Trigger DC Level (R60, R285). Page 5-24
 REQUIREMENT: Correct operation of trigger circuits; see complete procedure.
 PERFORMANCE: Correct _____; incorrect _____.
- 32. Check A and B Internal Triggering Operation. Page 5-25
 REQUIREMENT: Stable display in all positions of A and B COUPLING switches with 0.2-division display at 10 megahertz and one-division display at 50 megahertz.
 PERFORMANCE: Correct _____; incorrect (list exceptions) _____.
- 33. Check A and B External Triggering Operation. Page 5-25
 REQUIREMENTS: Stable display in all positions of A and B COUPLING switches with 50-millivolt signal at 10 megahertz and a 200-millivolt signal at 50 megahertz.
 PERFORMANCE: Correct _____; incorrect (list exceptions) _____.
- 34. Check A and B Low Frequency Triggering Operation. Page 5-26
 REQUIREMENT: Internal, stable display in AC, HF REJ, and DC positions of A and B COUPLING switches with 0.2-division display at 60 hertz; ex-

ternal, stable display in AC, HF REJ, and DC positions of A and B COUPLING switches with a 50-millivolt signal at 60 hertz.

PERFORMANCE: Correct _____; incorrect (list exceptions) _____.

- 35. Check A and B High-Frequency Reject Operation. Page 5-27
 REQUIREMENT: Stable display with 0.2-division display at 50 kilohertz; does not trigger at one megahertz.
 PERFORMANCE: Correct _____; incorrect (list exceptions) _____.
- 36. Check A and B Low-Frequency Reject Operation. Page 5-27
 REQUIREMENT: Stable display with 0.2-division display at 30 kilohertz; does not trigger at 60 hertz.
 PERFORMANCE: Correct _____; incorrect (list exceptions) _____.
- 37. Check Single Sweep Operation. Page 5-28
 REQUIREMENT: Sweep triggers at same A LEVEL control setting as in AUTO TRIG; after each sweep, further displays are locked out until the RESET button is pressed.
 PERFORMANCE: Correct _____; incorrect _____.
- 38. Check A and B Slope Switch Operation. Page 5-28
 REQUIREMENT: Stable triggering on correct slope of trigger signal.
 PERFORMANCE: Correct _____; incorrect _____.
- 39. Check A and B Level Control Range. Page 5-28
 REQUIREMENT: EXT, at least + and — 2 volts; EXT ÷10, at least + and — 20 volts.
 PERFORMANCE: Correct _____; incorrect (list exceptions) _____.
- 40. Check Line Triggering Operation. Page 5-29
 REQUIREMENT: Stable display of line-frequency signal, triggered on the correct polarity.
 PERFORMANCE: Correct _____; incorrect _____.
- 41. Check Auto Recovery Time and Operation. Page 5-29
 REQUIREMENT: Stable display with 50-millisecond markers (20 hertz); free-running display with 0.1-second markers.
 PERFORMANCE: Correct _____; incorrect _____.
- 42. Adjust Sweep Start and A Sweep Calibration (R531, R758). Page 5-30
 REQUIREMENT: Correct operation of sweep circuits; see complete procedure.
 PERFORMANCE: Correct _____; incorrect (list exceptions) _____.
- 43. Adjust Normal Gain (R835). Page 5-31
 REQUIREMENT: Correct A sweep timing at 1 ms/DIV.
 PERFORMANCE: Correct _____; incorrect _____.

Performance Check/Calibration—Type 453/R453

- 44. Adjust Magnified Gain (R845). Page 5-31
 REQUIREMENT: Correct A sweep timing at 1 ms/DIV with the MAG switch set to $\times 10$; see complete procedure.
 PERFORMANCE: Correct _____; incorrect _____.
- 45. Adjust Magnifier Register (R855). Page 5-32
 REQUIREMENT: Less than 0.2-division shift when switching MAG switch from $\times 10$ to OFF.
 PERFORMANCE: _____ division.
- 46. Adjust B Sweep Calibration (R741). Page 5-32
 REQUIREMENT: Correct B sweep timing at 1 ms/DIV.
 PERFORMANCE: Correct _____; incorrect _____.
- 47. Check B Sweep Length. Page 5-33
 REQUIREMENT: 11.0 divisions, ± 0.5 division.
 PERFORMANCE: 11.0 divisions, \pm _____ division.
- 48. Check A Sweep Length. Page 5-33
 REQUIREMENT: Variable from four divisions, or less, to 11.0 divisions, ± 0.5 division.
 PERFORMANCE: Correct _____; incorrect _____.
- 49. Check B Ends A Operation. Page 5-34
 REQUIREMENT: A sweep ends immediately after the end of B sweep when the A SWEEP LENGTH control is set to B ENDS A.
 PERFORMANCE: Correct _____; incorrect _____.
- 50. Check A Variable Control Range. Page 5-34
 REQUIREMENT: Uncalibrated sweep rate of at least 2.5 times the TIME/DIV indication.
 PERFORMANCE: Correct _____; incorrect _____.
- 51. Check B Variable Control Range. Page 5-34
 REQUIREMENT: Uncalibrated sweep rate of at least 2.5 times the TIME/DIV indication.
 PERFORMANCE: Correct _____; incorrect _____.
- 52. Adjust A and B One Microsecond Timing Page 5-34 (C530A, C740A).
 REQUIREMENT: Correct A and B sweep timing $\pm 2\%$ at 1 μs /DIV.
 PERFORMANCE: Correct _____; incorrect _____.
- 53. Adjust High-Speed Linearity (C882, C892). Page 5-35
 REQUIREMENT: $\pm 1.5\%$ for any eight division portion of the total magnified sweep length (excluding first and last 60 nanoseconds of magnified sweep).
 PERFORMANCE: Correct _____; incorrect (list exceptions) _____.
- 54. Check A Sweep Timing Accuracy. Page 5-35
 REQUIREMENT: Within 3% over middle eight divisions of the display.
 PERFORMANCE: Correct _____; incorrect (list exceptions) _____.
- 55. Check A Magnified Sweep Accuracy. Page 5-36
 REQUIREMENT: Within 4% over middle eight divisions of the CRT display with the MAG switch set to $\times 10$. Magnifier light must be on.
 PERFORMANCE: Correct _____; incorrect (list exceptions) _____.
- 56. Check B Sweep Timing Accuracy. Page 5-36
 REQUIREMENT: Within 3% over middle eight divisions of the display.
 PERFORMANCE: Correct _____; incorrect (list exceptions) _____.
- 57. Check B Magnified Sweep Accuracy. Page 5-36
 REQUIREMENT: Within 4% over middle eight divisions of the CRT display with the MAG switch set to $\times 10$.
 PERFORMANCE: Correct _____; incorrect (list exceptions) _____.
- 58. Check Delay-Time Accuracy. Page 5-36
 REQUIREMENT: DELAY TIME switch (A TIME/DIV) settings of 1 μs to 50 ms, within 1.5%; .1 s to 5 s, within 2.5%.
 PERFORMANCE: Correct _____; incorrect (list exceptions) _____.
- 59. Check Delay-Time Multiplier Incremental Page 5-37 Linearity.
 REQUIREMENT: Within 0.2%.
 PERFORMANCE: Correct _____; incorrect _____.
- 60. Check Delay-Time Jitter. Page 5-38
 REQUIREMENT: One part, or less, in 20,000.
 PERFORMANCE: Correct _____; incorrect _____.
- 61. Adjust External Horizontal Gain (R645). Page 5-38
 REQUIREMENT: Correct horizontal deflection $\pm 2\%$ for external horizontal mode operation in the 20 mV CH 1 VOLTS/DIV switch position.
 PERFORMANCE: Correct _____; incorrect _____.
- 62. Check External Horizontal Operation. Page 5-39
 REQUIREMENT: B SOURCE switch set to EXT, 270 millivolts/division, $\pm 15\%$; B SOURCE switch set to EXT $\div 10$, 2.7 volts/division, $\pm 20\%$.
 PERFORMANCE: Correct _____; incorrect (list exceptions) _____.
- 63. Check X-Y Phasing. Page 5-39
 REQUIREMENT: 3° or less phase shift up to 50 kilohertz.
 PERFORMANCE: Correct _____; incorrect _____.
- 64. Check X Bandwidth in External Page 5-39 Horizontal Mode.
 REQUIREMENT: Not more than -3 dB at five megahertz.
 PERFORMANCE: -3 dB at _____ megahertz.

Performance Check/Calibration—Type 453/R453

65. Check Beam Finder Operation. Page 5-40
REQUIREMENT: Display remains within graticule area when TRACE FINDER button is depressed regardless of the deflection factor or POSITION control settings.
PERFORMANCE: Correct _____; incorrect _____.
66. Check Chopped Operation. Page 5-40
REQUIREMENT: Chopped repetition rate, 500 kilohertz $\pm 20\%$; time segment displayed from each channel, about one microsecond; switching transients blanked out.
PERFORMANCE: _____ kilohertz repetition rate; _____ microsecond time segment; blanking correct _____; incorrect _____.
67. Adjust Calibrator Repetition Rate (T1255). Page 5-40
REQUIREMENT: One kilohertz, $\pm 0.5\%$.
PERFORMANCE: One kilohertz, \pm _____%.
68. Check Calibrator Duty Cycle. Page 5-41
REQUIREMENT: 49% to 51%.
PERFORMANCE: _____%.
69. Check Calibrator Risetime. Page 5-41
REQUIREMENT: One microsecond or less.
PERFORMANCE: _____ microsecond.
70. Check Current Through Probe Loop. Page 5-42
REQUIREMENT: Five milliamperes.
PERFORMANCE: _____ milliamperes.
71. Adjust Z Axis Compensation (C1036). Page 5-42
REQUIREMENT: Optimum square corner on blanking pulse.
PERFORMANCE: Correct _____; incorrect _____.
72. Check External Z Axis Operation. Page 5-42
REQUIREMENT: Noticeable trace modulation with five-volt signal from DC to 50 megahertz.
PERFORMANCE: Correct _____; incorrect _____.
73. Check A Gate Output Signal. Page 5-43
REQUIREMENT: Polarity, positive going; Amplitude, 12 volts $\pm 10\%$; duration, about 11 times the A TIME/DIV switch setting.
PERFORMANCE: Polarity, correct _____; incorrect _____; Amplitude _____ volts; duration, correct _____, incorrect _____.
74. Check B + Gate Output Signal. Page 5-43
REQUIREMENT: Polarity, positive going; amplitude, 12 volts, $\pm 10\%$; duration, about 11 times the B TIME/DIV switch setting.
PERFORMANCE: Polarity, correct _____, incorrect _____; amplitude _____ volts; duration, correct _____, incorrect _____.

PERFORMANCE CHECK/CALIBRATION PROCEDURE

General

The following procedure is arranged in a sequence which allows the Type 453 to be calibrated with the least interaction of adjustments and reconnection of equipment. However, some adjustments affect the calibration of other circuits within the instrument. In this case, it will be necessary to check the operation of other parts of the instrument. When a step interacts with others, the steps which need to be checked are noted under "INTERACTION—".

Any needed maintenance should be performed before proceeding with calibration. Troubles which become apparent during calibration should be corrected using the techniques given in the Maintenance section.

The steps titled "Adjust . . . ①" in the following procedure provide a check of instrument performance, whenever possible, before the adjustment is made. The symbol ① is used to identify the steps in which an adjustment is made. To prevent recalibration of other circuits when performing a partial calibration, readjust only if the listed tolerance is not met. However, when performing a complete calibration, best overall performance will be provided if each adjustment is made to the exact setting, even if the "CHECK— . . ." is within the allowable tolerance.

In the following procedure, a test equipment required picture is shown for each major group of adjustments and checks. Each step continues from the equipment setup preceding the desired portion. Type 453 front-panel control titles referred to in this procedure are capitalized (e.g., HORIZ DISPLAY). Internal adjustment titles are initial capitalized only (e.g., Normal Gain).

The following procedure uses the equipment listed under Equipment Required. If equipment is substituted, control settings or test equipment setup may need to be altered to meet the requirements of the equipment used.

NOTE

All waveforms shown in this procedure are actual waveform photographs taken with a Tektronix Oscilloscope Camera System unless otherwise noted. Graticule lines have been photographically retouched.

Preliminary Procedure

1. Remove the top and bottom covers from the Type 453.
2. Connect the autotransformer to a suitable power source.

3. Connect the Type 453 to the autotransformer output.
4. Set the autotransformer output voltage to the center voltage of the range selected by the Line Voltage Selector assembly on the rear panel.
5. Set the Type 453 POWER switch to ON (set INTENSITY control fully counterclockwise). Allow at least 20 minutes warmup at 25° C, ±5° C, for checking the instrument to the given accuracy.
6. If only a Performance Check is being made, steps two, three, and four may be omitted.
7. Preset the Type 453 front-panel controls as follows:

CRT controls

INTENSITY	Counterclockwise
FOCUS	Midrange
SCALE ILLUM	As desired

Vertical controls (both channels if applicable)

VOLTS/DIV	20 mV
VARIABLE	CAL
POSITION	Midrange
Input Coupling	DC
MODE	CH 1
TRIGGER	NORM
INVERT	Pushed in

Triggering controls (both A and B if applicable)

LEVEL	Fully clockwise
SLOPE	+
COUPLING	AC
SOURCE	INT

Sweep controls

DELAY-TIME MULTIPLIER	Fully counterclockwise
A and B TIME/DIV	1 ms
A VARIABLE	CAL
A SWEEP MODE	NORM TRIG
B SWEEP MODE	TRIGGERABLE AFTER DELAY TIME
HORIZ DISPLAY	A
MAG	OFF
A SWEEP LENGTH	FULL
POSITION	Midrange
POWER	ON

Side-panel controls

B TIME/DIV VARIABLE	CAL
CALIBRATOR	1 V

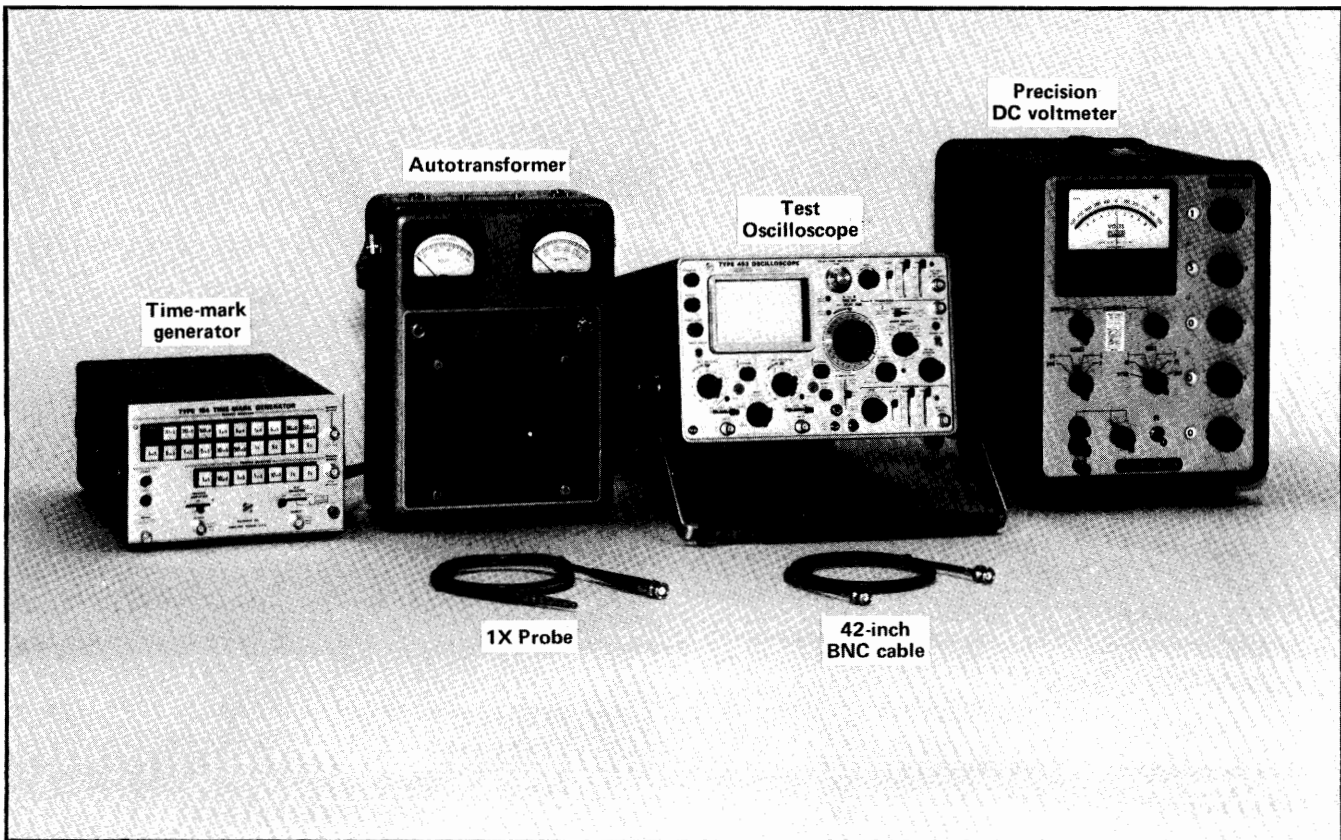

Fig. 5-1. Test equipment required for steps 1 through 12.

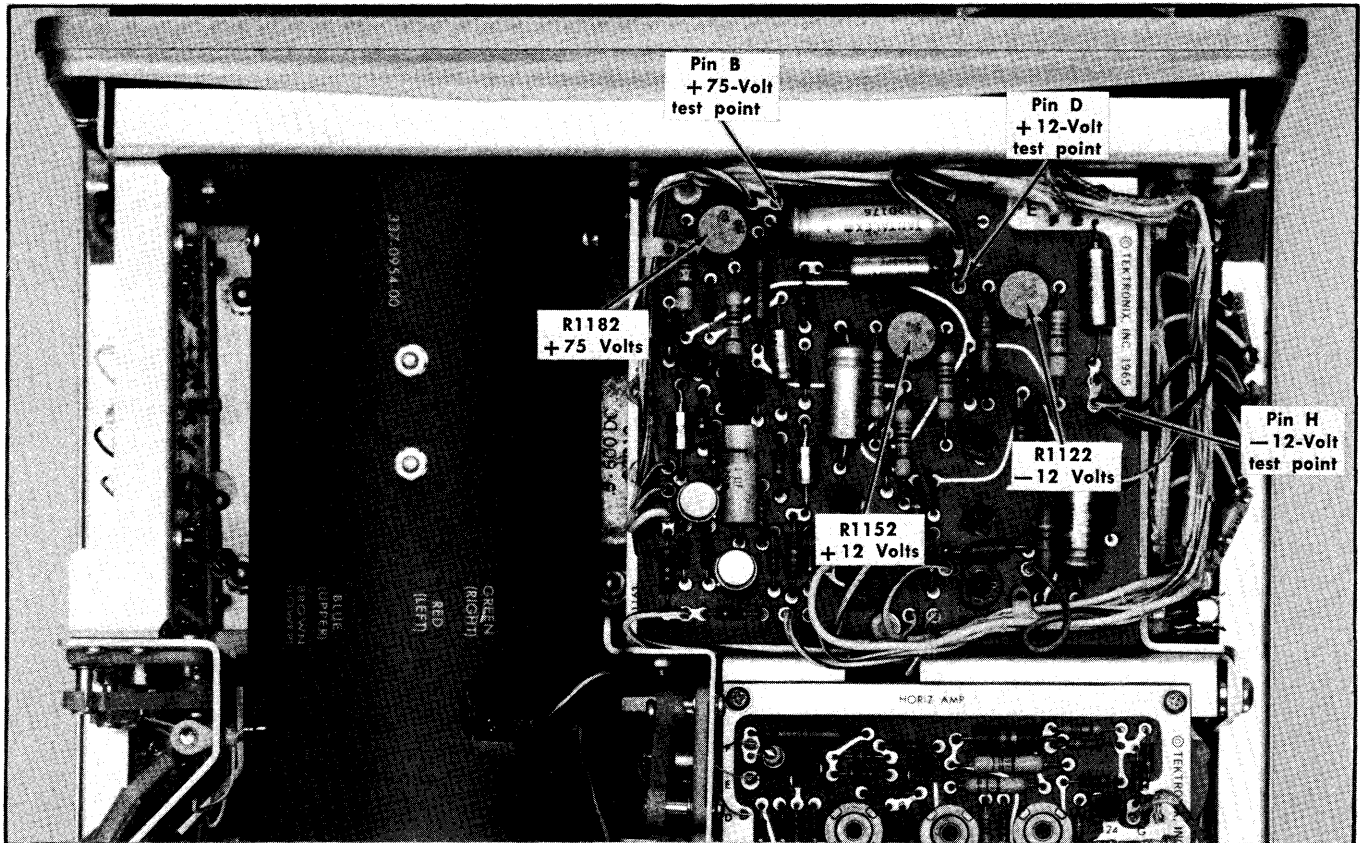

Fig. 5-2. Low-voltage power supply test points and adjustments (Low-Voltage Regulator circuit board).

1. Adjust -12-Volt Power Supply

PERFORMANCE CHECK ONLY

Steps 1 through 6 are not applicable to a performance check. Set controls as given under Preliminary Control Settings and begin with step 7.

- a. Test equipment setup is shown in Fig. 5-1.
- b. Connect the precision DC voltmeter from the -12-volt test point (pin connector 'H', Low Voltage Regulator Board; see Fig. 5-2) to chassis ground.
- c. CHECK—Meter reading; -12 volts, ± 0.12 volt.
- d. ADJUST—-12 Volts adjustment, R1122 (see Fig. 5-2), for -12 volts, ± 0.042 volt.
- e. INTERACTION—May affect operation of all circuits within the Type 453.

2. Adjust +12-Volt Power Supply

- a. Connect the precision DC voltmeter from the center contact of the 1 kHz CAL connector to chassis ground.
- b. Remove Q1255 (see Fig. 5-3) from the Calibrator section of the A Sweep circuit board.
- c. CHECK—Meter reading; +1 volt, ± 0.01 volt.



- d. ADJUST—+12 Volts adjustment, R1152 (see Fig. 5-2), for a +1 volt meter reading ± 0.003 volt.
- e. Set the CALIBRATOR switch (on side panel) to .1 V.
- f. CHECK—Meter reading; +0.1 volt, ± 0.001 volt.
- g. Replace Q1255.

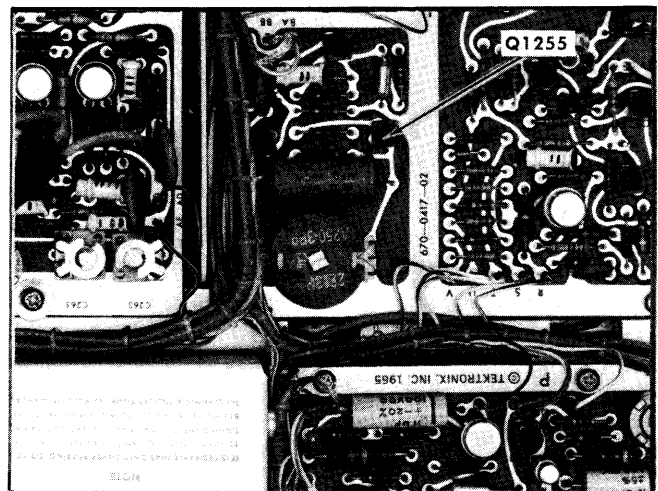

Fig. 5-3. Location of Q1255 (Calibrator section of A Sweep circuit board).

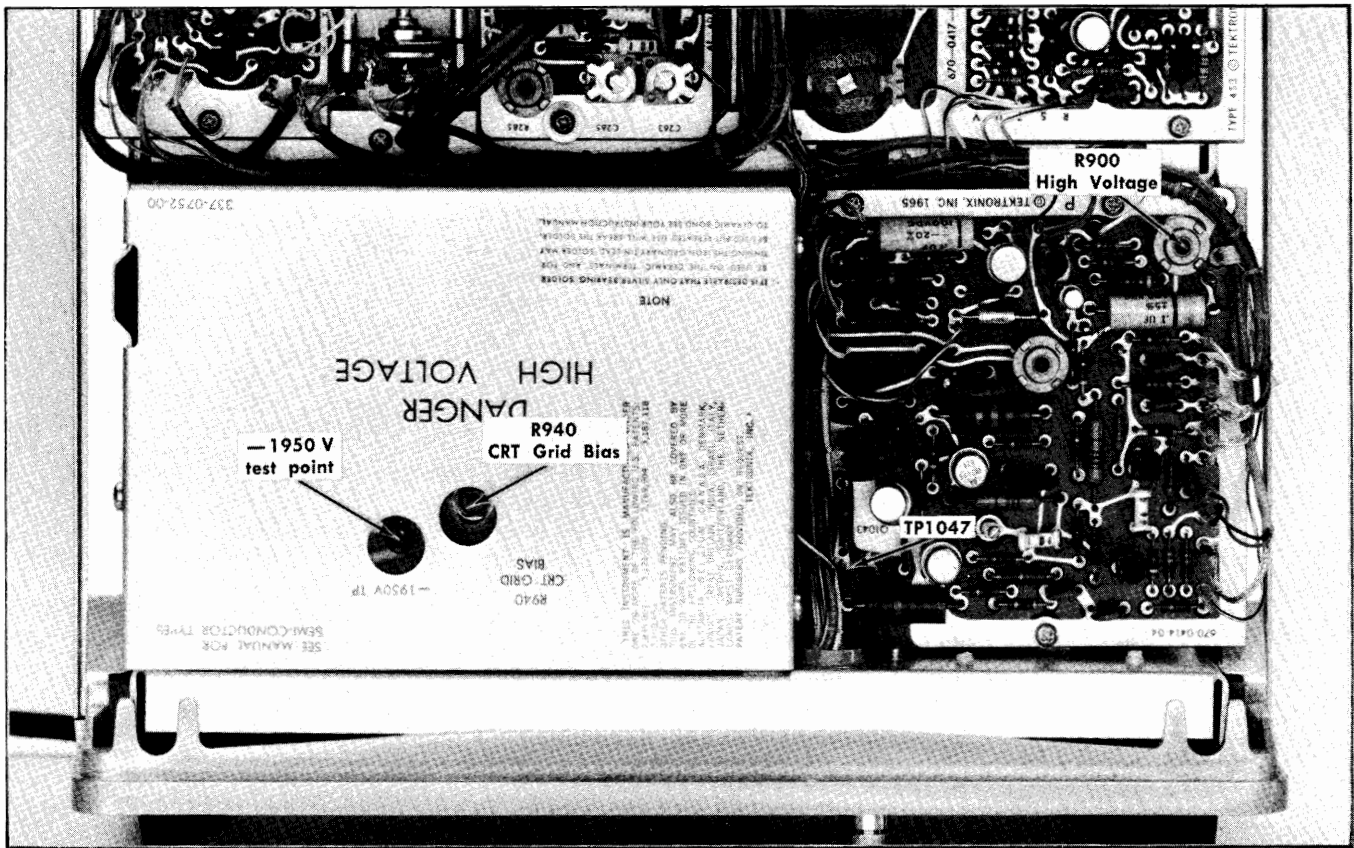

Fig. 5-4. Location of high-voltage adjustments and test points (bottom).

h. Connect the precision DC voltmeter from the +12-volt test point (pin connector 'D', Low-Voltage Regulator board; see Fig. 5-2) to chassis ground.

i. CHECK—Meter reading; +12.1 volts, ± 0.2 volt.

j. INTERACTION—May affect operation of all circuits within the Type 453.

3. Adjust +75-Volt Power Supply ①

a. Connect the precision DC voltmeter from the +75-volt test point (pin connector 'B', Low-voltage Regulator circuit board; see Fig. 5-2) to chassis ground.

b. CHECK—Meter reading; +75 volts, ± 0.75 volt.

c. ADJUST—+75 Volts adjustment, R1182 (see Fig. 5-2), for +75 volts, ± 0.278 volt.

d. Recheck all supplies and readjust if necessary.

e. INTERACTION—May affect operation of all circuits within the Type 453.

f. Disconnect all test equipment.

4. Adjust High-Voltage Supply and Check Regulation. ①

a. Connect the DC voltmeter (use the precision 2 kV divider) from the -1950 V test point (see Fig. 5-4) to chassis ground.

b. CHECK—Meter reading; -1950 volts, ± 58.5 volts.

c. ADJUST—High-Voltage adjustment, R900 (see Fig. 5-4), for -1950 volts ± 19.5 volts.

d. INTERACTION—May affect operation of all circuits within the Type 453.

e. CHECK—Change the autotransformer output voltage throughout the regulating range selected by the Line Voltage Selector assembly on the rear panel and check for less than ± 58.5 volts change in the high-voltage output level. Also vary the INTENSITY control throughout its range at the maximum and minimum line voltage; check that regulation remains within given limits.

NOTE

If the high voltage supply is out of regulation, check the regulation of the low-voltage supplies (step 6) before troubleshooting in the high-voltage supply.

Performance Check/Calibration—Type 453/R453

f. Return the autotransformer output voltage to the center of the regulating range selected by the Line Voltage Selector assembly.

5. Adjust CRT Grid Bias

- Connect the precision DC voltmeter from TP1047 (Z Axis Amplifier board; see Fig. 5-4) to chassis ground.
- Set the A SWEEP MODE switch to SINGLE SWEEP.
- Set the INTENSITY control for a meter reading of +12 volts.
- ADJUST—Crt Grid Bias adjustment, R940 (see Fig. 5-4), so the spot just disappears (it may be necessary to turn the horizontal POSITION control clockwise to bring the spot onto the viewing area).

CAUTION

Do not allow a bright spot to remain stationary for an extended period, as it may burn the CRT phosphor.

- INTERACTION—Check steps 65, 71, and 72.
- Disconnect the precision DC voltmeter.

6. Check Low Voltage Power Supply Ripple

NOTE

This step also checks regulation of the low-voltage supplies.

- Connect the $1\times$ probe to the test oscilloscope input.
- Set the test oscilloscope for a vertical deflection of 0.005 volts/division, AC coupled, at a sweep rate of five milliseconds/division. Use line-frequency triggering to produce a stable display.
- CHECK—Two millivolts (0.4 division) peak to peak maximum line frequency ripple on the -12-volt, +12-volt, and +75-volt supplies while changing the autotransformer output voltage throughout the regulating range selected by the Line Voltage Selector assembly on the rear panel. Power-supply test points are shown in Fig. 5-2. Fig. 5-5 shows a typical test oscilloscope display of ripple.
- Return autotransformer output voltage to the center of the regulating range selected by the Line Voltage Selector assembly. (If the line voltage is near the center of the regulating range, the Type 453 may be connected directly to the line; otherwise, leave the instrument connected to the autotransformer for the remainder of this procedure.)
- Disconnect all test equipment.

7. Check/Adjust Trace Alignment

- Set the A SWEEP MODE switch to AUTO TRIG.
- Advance the INTENSITY control until the trace is visible.

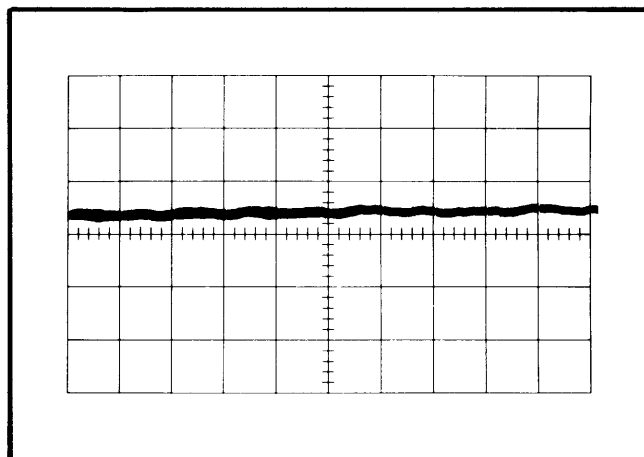

Fig. 5-5. Typical test oscilloscope display of power-supply ripple (60-cycle line). Vertical 0.005 volt/division, sweep rate, five milliseconds/division.

- Turn the Channel 1 POSITION control to move the trace to the center horizontal line.
- Set the FOCUS control for as sharp a display as possible.
- CHECK—The trace should be parallel with the center horizontal line.
- ADJUST—TRACE ROTATION adjustment, R980 (see Fig. 5-6), so the trace is parallel to the horizontal graticule lines.

8. Adjust Astigmatism

- Connect the time-mark generator (Type 184) to the Channel 1 INPUT connector with a 42-inch BNC cable.
- Set the time-mark generator for 1- and 0.1-millisecond markers.

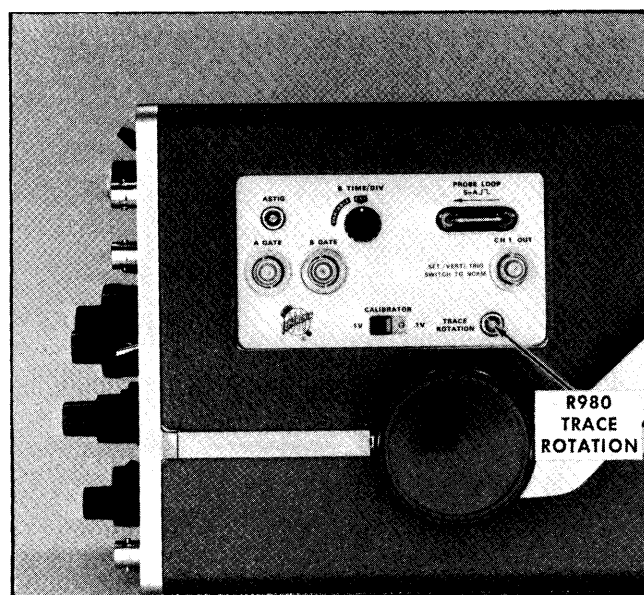

Fig. 5-6. Location of TRACE ROTATION adjustment (side panel).

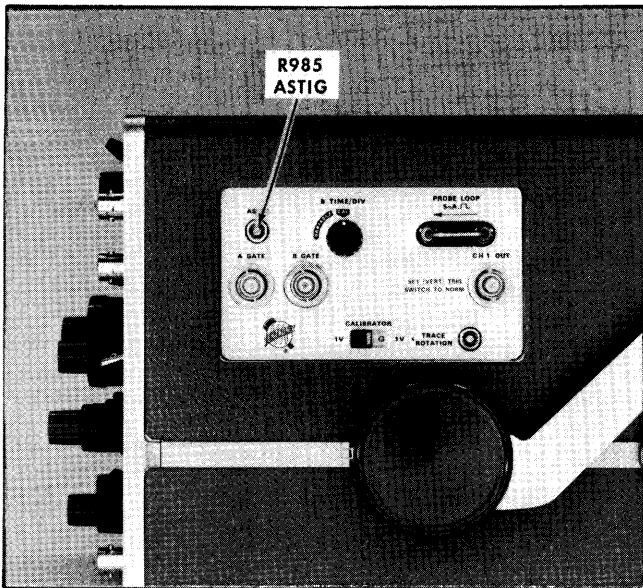

Fig. 5-7. Location of ASTIG adjustment (side panel).

- c. Set the CH 1 VOLTS/DIV switch so the large markers extend beyond the bottom and top of the graticule area.
- d. Set the A LEVEL control for a stable display.
- e. CHECK—Markers should be well defined with optimum setting of FOCUS control.
- f. ADJUST—FOCUS control and ASTIG adjustment, R985 (see Fig. 5-7), for best definition of the markers.

9. Check/Adjust Y Axis Alignment ①

- a. CHECK—The markers should be parallel to the center vertical line (see Fig. 5-8A).
- b. ADJUST Y Axis Align adjustment, R989 (see Fig. 5-8B), to align the markers with the center vertical line.

10. Check/Adjust CRT Geometry ①

- a. Set the horizontal POSITION and the A VARIABLE controls so a large marker coincides with each vertical graticule line.
- b. CHECK—Bowling and tilt of markers at left and right edges of the graticule. Fig. 5-9 shows a typical display of good geometry as well as examples of poor geometry.
- c. ADJUST—Geometry adjustment, R982 (see Fig. 5-9D), for minimum bowling of the trace at the left and right edges of the graticule.
- d. INTERACTION—Recheck step 9.
- e. Disconnect the time-mark generator.
- f. Position the trace to the top of the graticule area.

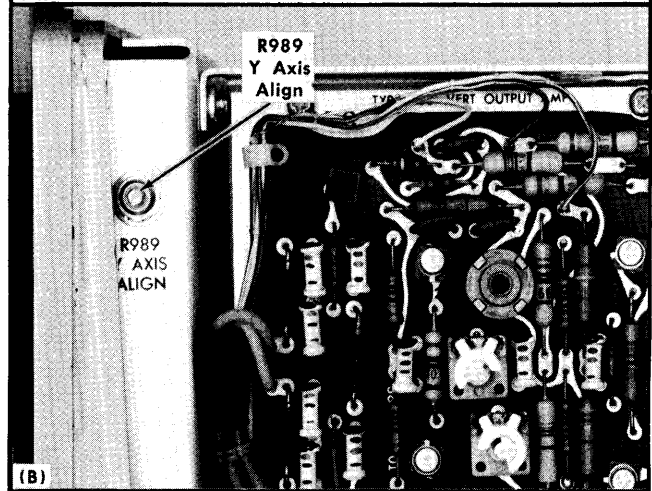
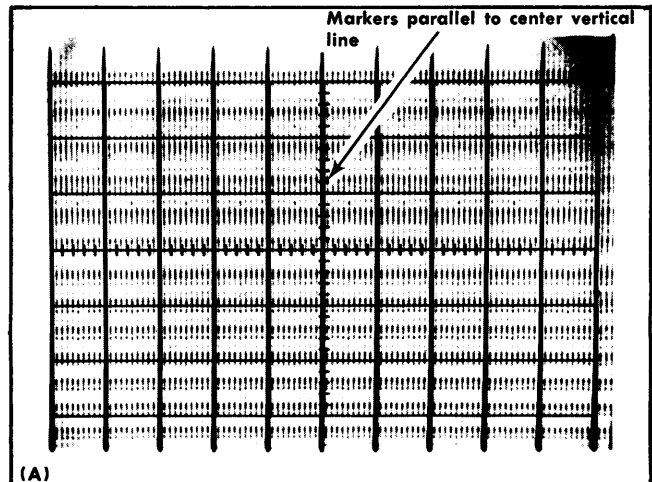

Fig. 5-8. (A) Typical CRT display showing correct Y-axis alignment, (B) location of Y Axis Align adjustment (left side).

- g. CHECK—Deviation from straight line should not exceed 0.1 division.
- h. Position the trace to the bottom of the graticule area.
- i. CHECK—Deviation from straight line should not exceed 0.1 division.
- j. Disconnect all test equipment.

11. Check/Adjust Channel 1 and 2 Step Attenuator Balance ①

- a. Position the trace to the center horizontal line with the Channel 1 POSITION control.
- b. Change the following control settings:

VOLTS/DIV	
(CH 1 and 2)	20 mV
Input Coupling	
(CH 1 and 2)	GND

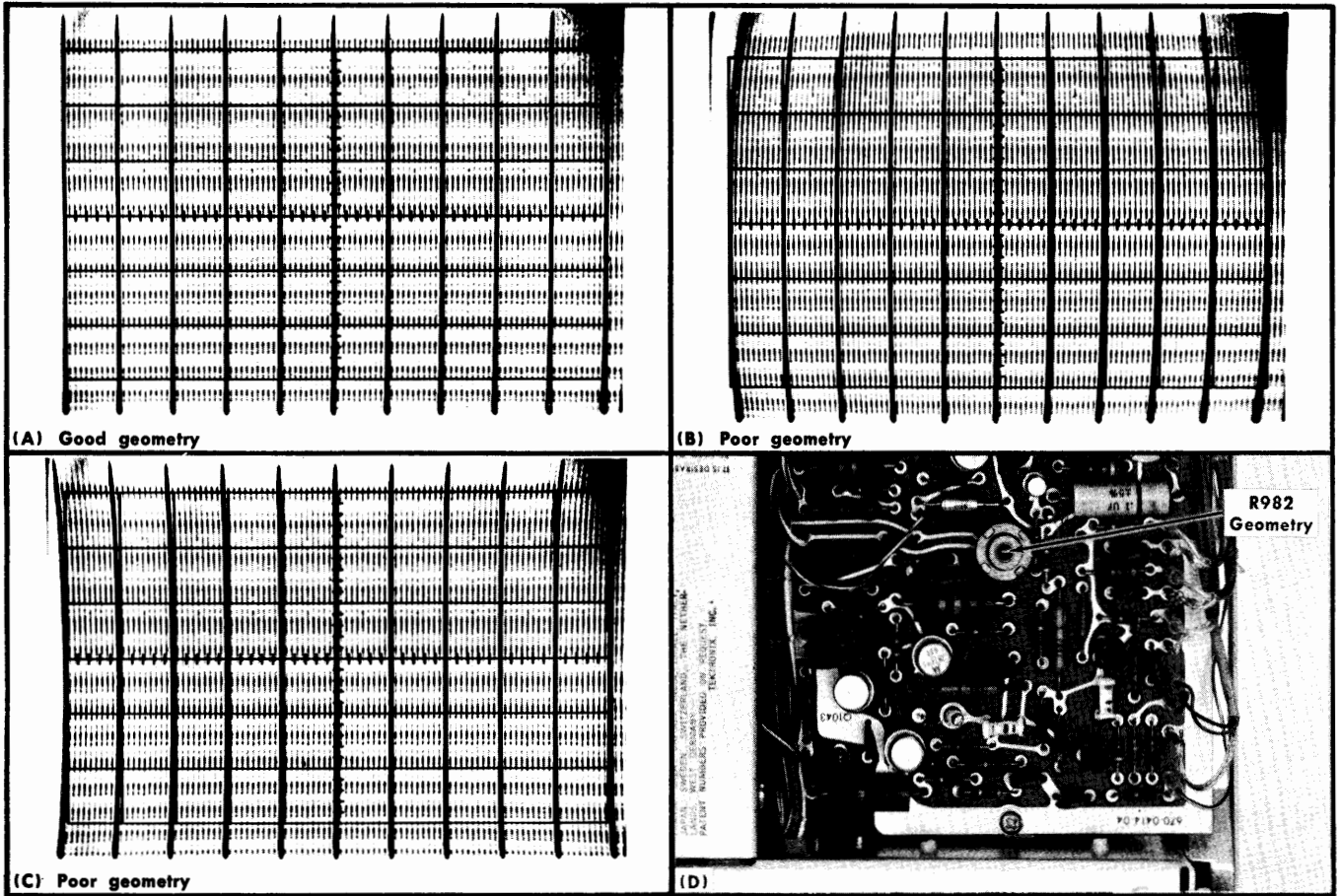

Fig. 5-9. (A) Typical CRT display showing good geometry; (B) and (C) poor geometry; (D) Location of Geometry adjustment (Z Axis Amplifier circuit board).

c. CHECK—Change the CH 1 VOLTS/DIV switch from 20 mV to 5 mV. Trace should not move vertically.

NOTE

Use the TRACE FINDER switch to locate the trace if it is deflected off screen when switching to 10 or 5 mV.

d. ADJUST—Channel 1 STEP ATTEN BAL adjustment, R30 (see Fig. 5-10), for no trace shift as the CH 1 VOLTS/DIV switch is changed from 20 mV to 5 mV.

e. Set the MODE switch to CH 2.

f. Position the trace to the center horizontal line with the Channel 2 POSITION control.

g. CHECK—Change the CH 2 VOLTS/DIV switch from 20 mV to 5 mV. Trace should not move vertically.

h. ADJUST—Channel 2 STEP ATTEN BAL adjustment, R130 (see Fig. 5-10), for no trace shift as the CH 2 VOLTS/DIV switch is changed from 20 mV to 5 mV.

12. Check/Adjust Channel 1 and 2 Position Center

a. Connect the precision DC voltmeter between the Channel 2 position center test point (pin connector 'Z') on the Vertical Preamp board (see Fig. 5-11) and chassis ground.

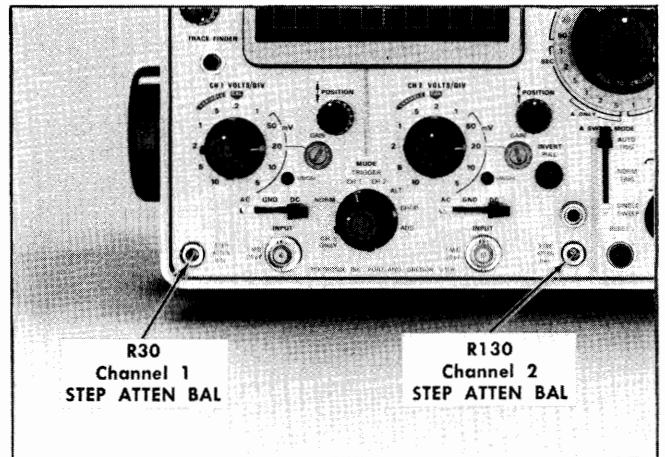

Fig. 5-10. Location of Channel 1 and 2 STEP ATTEN BAL adjustments (front panel).

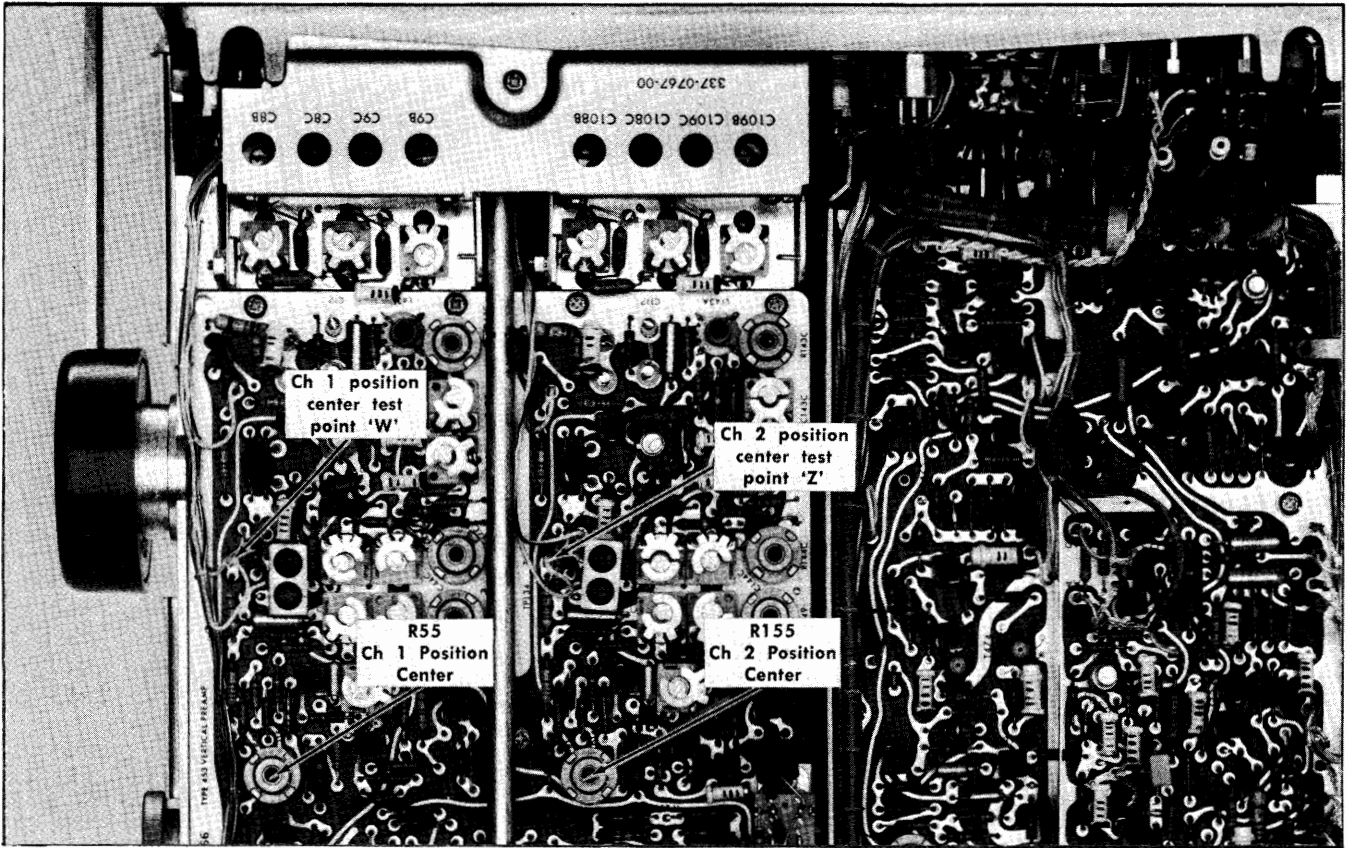

Fig. 5-11. Location of Channel 1 and 2 position center test points and adjustments (Vertical Preamp circuit board).

b. Set the Channel 2 POSITION control for a meter reading of zero volts. (The dot on the POSITION control should be centered mechanically. If not, loosen the set screw and reposition the knob.)

c. CHECK—Trace should be at the center horizontal line.

d. ADJUST—CH 2 Position Center adjustment, R155 (see Fig. 5-11), to position the trace to the center line.

e. Set the MODE switch to CH 1.

f. Connect the precision DC voltmeter between the Channel 1 position center test point (pin connector 'W') on the Vertical Preamp board (see Fig. 5-11), and chassis ground.

g. Set the Channel 1 POSITION control for a meter reading of zero volts. (The dot on the POSITION control should be centered mechanically. If not, loosen the set screw and reposition the knob.)

h. CHECK—Trace should be at the center horizontal line.

i. ADJUST—CH 1 Position Center adjustment, R55 (see Fig. 5-11), to position the trace to the center line.

j. INTERACTION—Recheck step 11 and the portion of 31 concerning DC TRIGGER Level Centering.

k. Disconnect all test equipment.

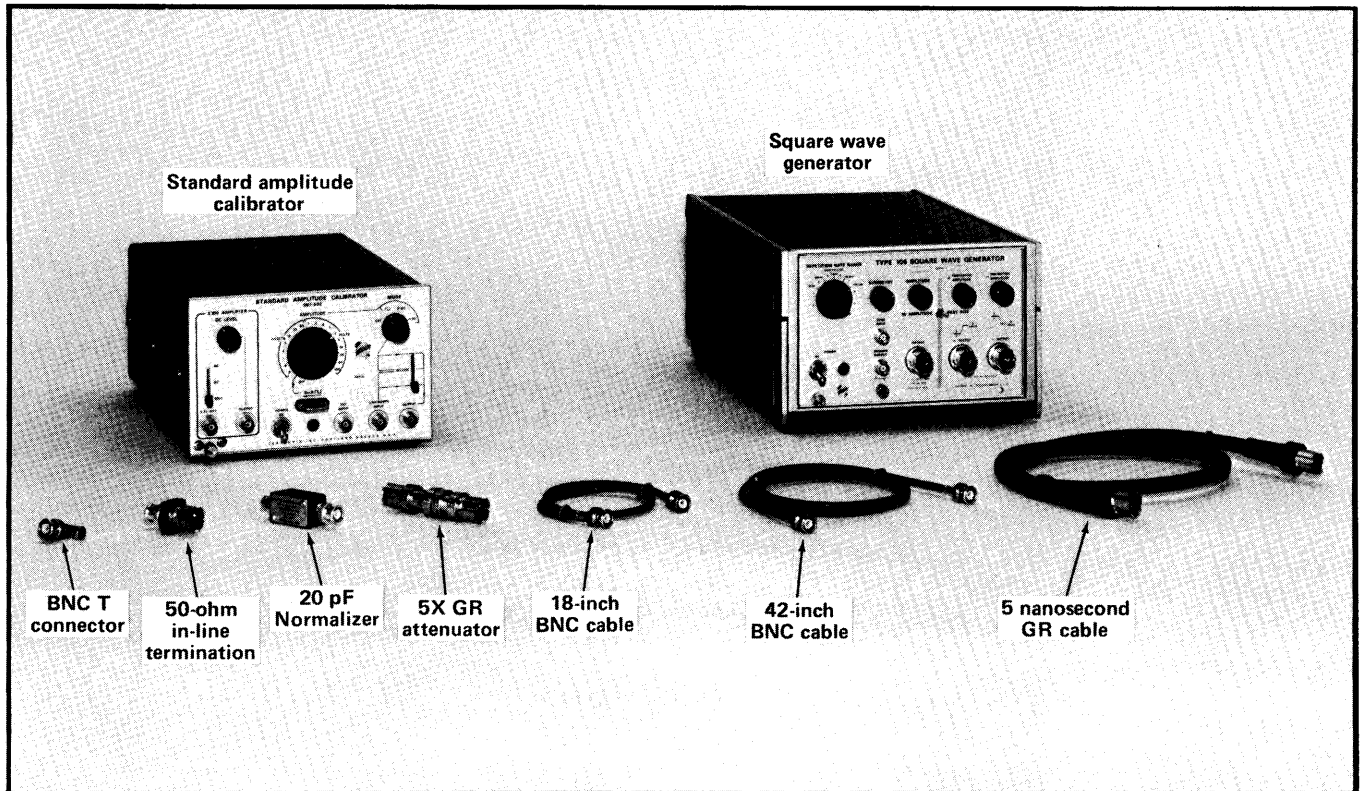

Fig. 5-12. Test equipment required for steps 13 through 24.

PARTIAL PROCEDURE

If beginning a partial procedure with this step, set the controls as given under Preliminary Control Settings except as follows:

FOCUS	Adjust for focused display
LEVEL	0
A and B TIME/DIV	.5 ms
A SWEEP MODE	AUTO TRIG

13. Check/Adjust Channel 1 and 2 Gain

- a. Test equipment required for steps 13 through 24 is shown in Fig. 5-12.
- b. Connect the standard amplitude calibrator (067-0502-00) output connector to the Channel 1 and 2 INPUT connectors through a BNC T connector and two 42-inch BNC cables.
- c. Set the standard amplitude calibrator for a 0.1-volt square-wave output.
- d. Position the display to the center of the graticule with the Channel 1 POSITION control.
- e. CHECK—CRT display exactly five divisions in amplitude (see Fig. 5-13A).
- f. ADJUST—Channel 1 GAIN adjustment, R90 (see Fig. 5-13), for exactly five divisions of deflection.
- g. Set the MODE switch to ADD.
- h. Pull the INVERT switch.

- i. CHECK—CRT display for straight line.
- j. ADJUST—Channel 2 GAIN adjustment, R190 (see Fig. 5-13B), for a straight line display.

14. Check Added Mode Operation

- a. Push the INVERT switch in.
- b. Set the standard amplitude calibrator for a 50-milli-volt square-wave output.
- c. CHECK—CRT display five divisions in amplitude, ± 0.05 division.

15. Check Channel 1 and 2 Deflection Accuracy

- a. Set the MODE switch to CH 1.
- b. Set the Channel 2 Input Coupling switch to GND.
- c. CHECK—Using the CH 1 VOLTS/DIV switch and standard amplitude calibrator settings given in Table 5-1, check vertical deflection within 3% in each position of the CH 1 VOLTS/DIV switch.
- d. Set the MODE switch to CH 2.
- e. Set the Channel 1 Input Coupling switch to GND and Channel 2 Input Coupling switch to DC.
- f. CHECK—Using the CH 2 VOLTS/DIV switch and standard amplitude calibrator settings given in Table 5-1, check vertical deflection within 3% in each position of the CH 2 VOLTS/DIV switch.

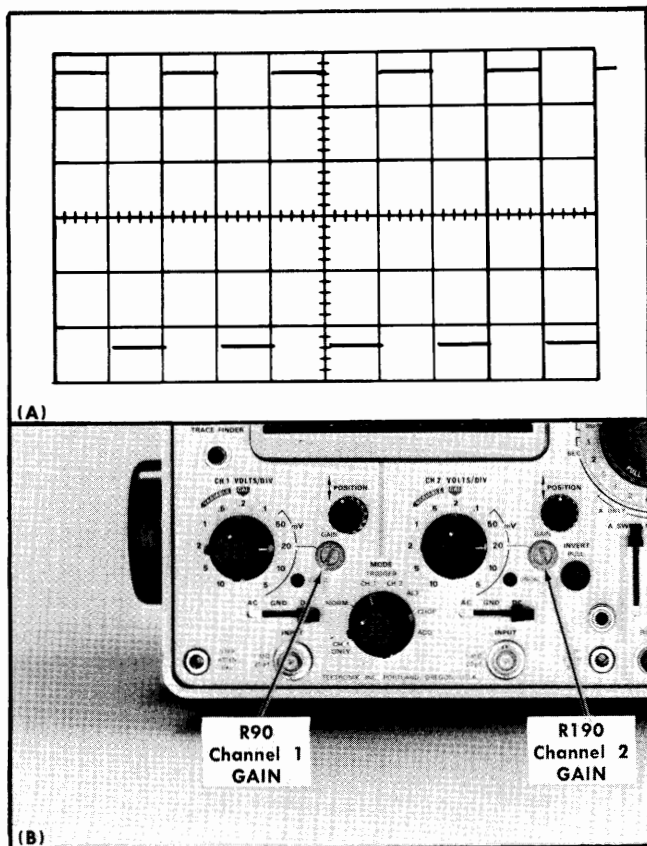

Fig. 5-13. (A) Typical CRT display showing correct gain adjustments; (B) location of Channel 1 and 2 GAIN adjustments (front panel).

TABLE 5-1

VOLTS/DIV Switch Setting	Standard Amplitude Calibrator Output	Vertical Deflection In Divisions	Maximum Error for $\pm 3\%$ Accuracy (divisions)
5 mV	20 millivolts	4	± 0.12
10 mV	50 millivolts	5	± 0.15
20 mV	0.1 volt	5	Previously set in step 13
50 mV	0.2 volt	4	± 0.12
.1	0.5 volt	5	± 0.15
.2	1 volt	5	± 0.15
.5	2 volts	4	± 0.12
1	5 volts	5	± 0.15
2	10 volts	5	± 0.15
5	20 volts	4	± 0.12
10	50 volts	5	± 0.15

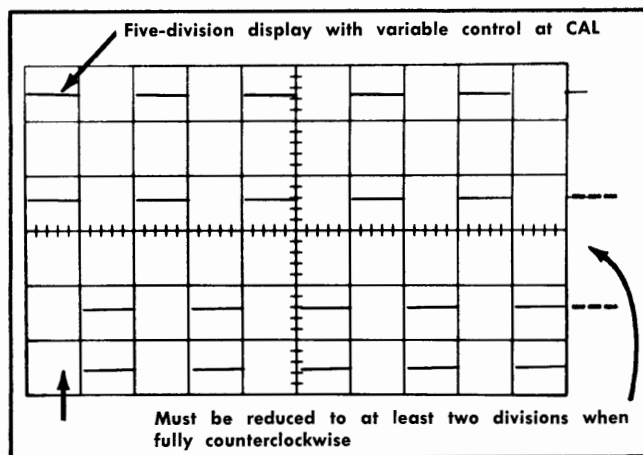

Fig. 5-14. Typical CRT display showing adequate Channel 1 and 2 VARIABLE control range (double exposure).

16. Check Channel 1 and 2 Variable Volts/Division Range

a. Set the standard amplitude calibrator for a 0.1-volt square-wave output.

b. Change the following control settings:

VOLTS/DIV
(CH 1 and 2) 20 mV

Input Coupling
(CH 1 and 2) AC

MODE CH 1

c. CHECK—Turn the Channel 1 VARIABLE VOLTS/DIV control fully counterclockwise. Display should be reduced to two divisions or less (see Fig. 5-14). Channel 1 UNCAL light must be on when Channel 1 VARIABLE control is not in CAL position.

d. Set the MODE switch to CH 2.

e. CHECK—Turn the Channel 2 VARIABLE VOLTS/DIV control fully counterclockwise. Display should be reduced to two divisions or less (see Fig. 5-14). Channel 2 UNCAL light must be on when Channel 2 VARIABLE control is not in CAL position.

f. Disconnect the cable from the Channel 2 INPUT connector.

17. Check Channel 1 and 2 Cascaded Deflection Factor

a. Connect the CH 1 OUT connector to the Channel 2 INPUT connector with the 18-inch 50-ohm BNC cable.

b. Change the following control settings:

VOLTS/DIV
(CH 1 and 2) 5 mV

Performance Check/Calibration—Type 453/R453

VARIABLE CAL
(CH 1 and 2)

Input Coupling DC
(CH 1 and 2)

c. Set the standard amplitude calibrator for a five millivolt square-wave output.

d. CHECK—CRT display five divisions or greater in amplitude (one millivolt/division, or less, minimum deflection factor).

18. Check Channel 1 and 2 Input Coupling Switch Operation

a. Set the CH 1 and CH 2 VOLTS/DIV switches to 20 mV.

b. Disconnect the 18-inch BNC cable from the Channel 2 INPUT connector and reconnect the standard amplitude calibrator to the Channel 2 INPUT connector.

c. Set the standard amplitude calibrator for a 50-millivolt square-wave output.

d. Position the display with the Channel 2 POSITION control so the bottom of the square wave is at the center horizontal line.

e. Set the Channel 2 Input Coupling switch to GND.

f. CHECK—CRT display for straight line near the center horizontal line.

g. Set the Channel 2 Input Coupling switch to AC.

h. CHECK—CRT display centered about center horizontal line.

i. Set the MODE switch to CH 1.

j. Position the display with the Channel 1 POSITION control so the bottom of the square wave is at the center horizontal line.

k. Set the Channel 1 Input Coupling switch to GND.

l. CHECK—CRT display for straight line near the center horizontal line.

m. Set the Channel 1 Input Coupling switch to AC.

n. CHECK—CRT display centered about center horizontal line.

19. Check Low-Frequency Vertical Linearity

a. Set the Channel 1 and 2 Input Coupling switches to DC.

b. Position the display to the center of the graticule with the Channel 1 POSITION control.

c. Adjust the Channel 1 VARIABLE control for exactly two divisions of deflection.

d. Position the top of the display to the top horizontal line.

e. CHECK—Compression or expansion 0.15 division or less (see Fig. 5-15).

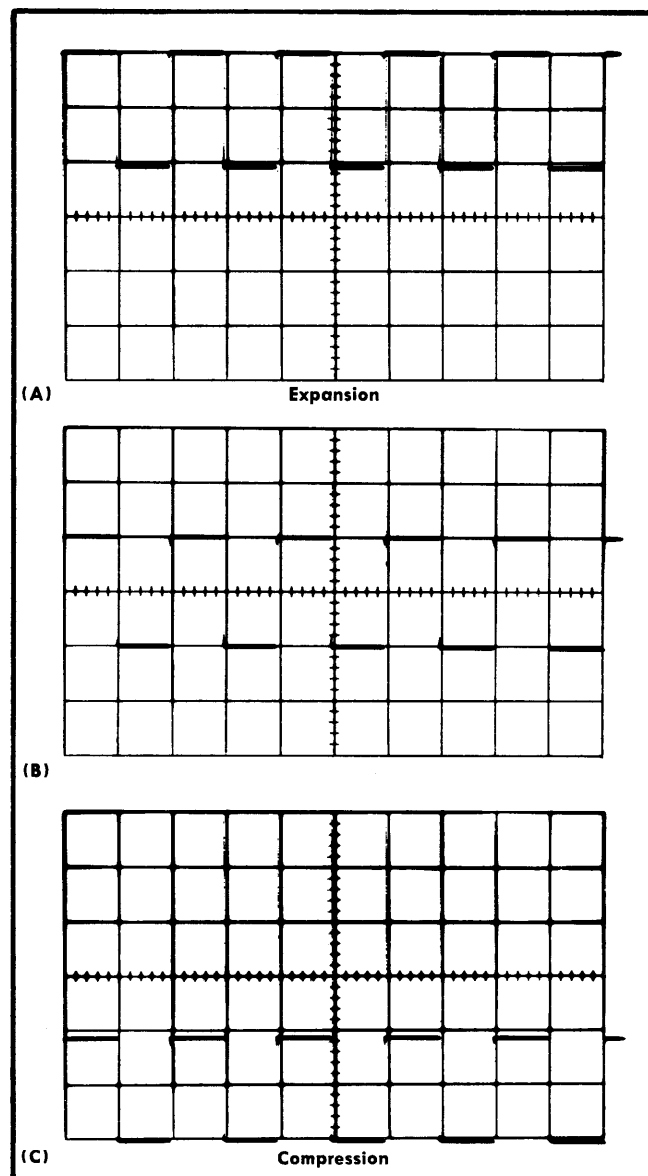

Fig. 5-15. Typical CRT display showing acceptable compression and expansion. (A) Expansion, (B) correct deflection at center of graticule, (C) compression.

f. Position the bottom of the display to the bottom horizontal line.

g. CHECK—Compression or expansion 0.15 division or less (see Fig. 5-15).

h. Set the MODE switch to CH 2.

i. Position the display to the center of the graticule with the Channel 2 POSITION control.

j. Set the Channel 2 VARIABLE control for exactly two divisions of deflection.

k. Position the top of the display to the top horizontal line.

l. CHECK—Compression or expansion 0.15 division or less (see Fig. 5-15).

- m. Position the bottom of the display to the bottom horizontal line.
- n. CHECK—Compression or expansion 0.15 division or less (see Fig. 5-15).
- o. Disconnect all test equipment.

20. Check Trace Shift Due to Input Gate Current

- a. Change the following control settings:

VOLTS/DIV	
(CH 1 and 2)	5 mV
VARIABLE	
(CH 1 and 2)	CAL
Input Coupling	
(CH 1 and 2)	GND
LEVEL	Clockwise

- b. Position the trace to the center horizontal line with the Channel 2 POSITION control.
- c. CHECK—Set the Channel 2 Input Coupling switch to DC. Trace shift should be negligible.
- d. Set the MODE switch to CH 1.
- e. Position the trace to the center horizontal line with the Channel 1 POSITION control.
- f. CHECK—Set the Channel 1 Input Coupling switch to DC. Trace shift should be negligible.

21. Check Alternate Operation

- a. Set the MODE switch to ALT.
- b. Position the traces about two divisions apart.
- c. Turn the A TIME/DIV switch throughout its range.
- d. CHECK—Trace alternation between Channel 1 and 2 at all sweep rates. At faster sweep rates, alternation is not apparent; instead display appears as two traces on the screen.

22. Check/Adjust Channel 1 and 2 Volts/Division Switch Series Compensation

- a. Change the following control settings:

VOLTS/DIV	
(CH 1 and 2)	20 mV
Input Coupling	
(CH 1 and 2)	DC
MODE	CH 1
A and B TIME/DIV	.2 ms

- b. Connect the square-wave generator (Type 106) high-amplitude output connector to the Channel 1 INPUT connector through the five-nanosecond GR cable, 5X GR attenuator and 50-ohm in-line termination in given order.

- c. Set the square-wave generator for four divisions of one-kilohertz signal.

- d. Set the A LEVEL control for a stable display.

- e. CHECK—CRT display at each CH 1 VOLTS/DIV switch setting listed in Table 5-2 for optimum square corner (see Fig. 5-16A, B, and C).

- f. ADJUST—CH 1 VOLTS/DIV switch series compensation as given in Table 5-2 for optimum square corner on the display. Readjust the generator output with each setting of the CH 1 VOLTS/DIV switch (remove 5X attenuator as required) to provide four divisions of deflection. Fig. 5-16D shows the location of the variable capacitors.

- g. Disconnect the signal from the Channel 1 INPUT connector and reconnect it to the Channel 2 INPUT connector through the five-nanosecond GR cable, 5X GR attenuator and 50-ohm in-line termination.

- h. Set the MODE switch to CH 2.

- i. CHECK—CRT display at each CH 2 VOLTS/DIV switch setting listed in Table 5-2 for optimum square corner (see Fig. 5-16A, B, and C). Remove 5X attenuator as required.

- j. ADJUST—CH 2 VOLTS/DIV switch series compensation as given in Table 5-2 for optimum square corner on the display. Readjust the generator output with each setting of the CH 2 VOLTS/DIV switch (remove 5X attenuator as required) to provide four divisions of deflection. Fig. 5-16D shows the location of the variable capacitors.

- k. Disconnect the test equipment from the Channel 2 INPUT connector.

TABLE 5-2

Channel 1 and 2 VOLTS/DIV Series Compensation

CH 1 VOLTS/DIV Switch Setting	Channel 1 Series Compensation	Channel 2 Series Compensation
50 mV	C6C	C106C
.1	C7C	C107C
.2	C8C	C108C
2	C9C	C109C

TABLE 5-3

Channel 2 VOLTS/DIV Shunt Compensation

CH 2 VOLTS/DIV Switch Setting	Channel 1 shunt compensation	Channel 2 shunt compensation
20 mV	C17	C117
50 mV	C6B	C106B
.1	C7B	C107B
.2	C8B	C108B
.5	Adjust C11 for best compromise	Adjust C111 for best compromise
1		
2	C9B	C109B

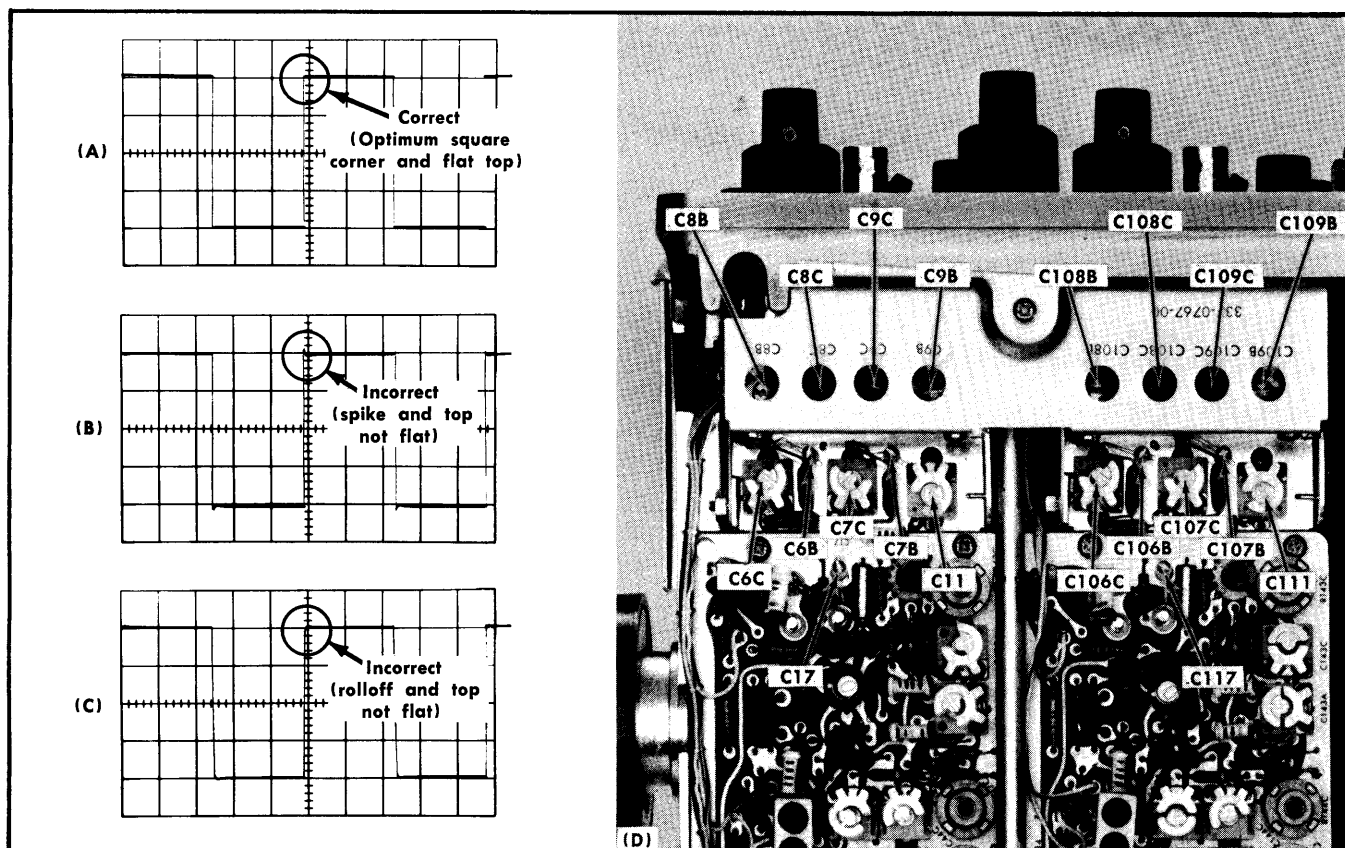

Fig. 5-16. (A) Typical CRT display showing correct compensation; (B) and (C) incorrect compensation; (D) location of variable capacitor (bottom view).

23. Check/Adjust Channel 1 and 2 Volts/Division Shunt Compensation

- a. Connect the square-wave generator high-amplitude output connector to the Channel 2 INPUT connector through the five-nanosecond GR cable, 5× GR attenuator, 50-ohm in-line termination and 20 pF input RC normalizer, in given order.
- b. Set the CH 2 VOLTS/DIV switch to 20 mV.
- c. Set the square-wave generator for four divisions of one-kilohertz signal.
- d. CHECK—CRT display at each CH 2 VOLTS/DIV switch setting listed in Table 5-3 for optimum flat top (see Fig. 5-16A, B, and C).
- e. ADJUST—CH 2 VOLTS/DIV switch shunt compensation as given in Table 5-3 for optimum flat top on the display. Readjust the generator output with each setting of the CH 2 VOLTS/DIV switch (remove the 5× attenuator as required) to provide four divisions of deflection (only about three

divisions obtainable in 2 position). Fig. 5-16D shows the location of the variable capacitors.

- f. Disconnect the signal from the Channel 2 INPUT connector and reconnect it to the Channel 1 INPUT connector through the five-nanosecond GR cable, 5× GR attenuator, 50-ohm in-line termination and 20 pF input RC normalizer, in given order.

g. Set the MODE switch to CH 1.

- h. CHECK—CRT display at each CH 1 VOLTS/DIV switch setting listed in Table 5-3 for optimum square corner (see Fig. 5-16A, B, and C). Remove the 5× attenuator as required.

i. ADJUST—CH 1 VOLTS/DIV switch shunt compensation as given in Table 5-3 for optimum flat top on the display. Readjust the generator output with each setting of the CH 1 VOLTS/DIV switch (remove 5× attenuator as required) to provide four divisions of deflection (only about three divisions obtainable in 2 position). Fig. 5-16D shows the location of the variable capacitors.

- j. Disconnect all test equipment.

TABLE 5-4

Selected Component	Range of Values (to provide a 2 to 3% total compensating effect)	Device(s) for which this provides a compensating effect	Conditions for selecting (20 mV/DIV, four-division 100 kHz signal applied)	Selection procedure
1. C38	.001 to .01 μ F	Q23, Q33	MODE CH 1 10 μ s/DIV MAG OFF	Select for best flat top over first 2 to 5 microseconds
2. C264	14 to 47 pF	Delay line	MODE CH 1 2 μ s/DIV MAG OFF	Select for best flat top over first 0.2 to 0.6 microseconds
3. C138	.001 to .01 μ F	Q123, Q133	MODE CH 2 10 μ s/DIV MAG OFF	Select for best flat top over first 2 to 5 microseconds
4. R195	24 k to 300 k Ω	Q84, Q94, Q184, Q194	MODE CH 2 2 μ s/DIV MAG OFF	Select for best match of Channel 2 to Channel 1 over first 0.5 microsecond

24. Check/Adjust High-Frequency Compensation

SELECTED COMPONENTS

The Vertical Preamp circuit board has four selected components which provide high-frequency compensation for various devices within the Vertical Deflection System. It should not be necessary to re-select these components unless the devices for which they compensate have been changed. Use Table 5-4 to select these components. If more than one component needs to be selected, select the components in the order given in this table. All of the selected components except R195 are mounted in sockets in the circuit board to facilitate selection. The location of each selected component is shown on Fig. 5-17. Table 5-4 lists the range of component values which provide correct compensation.

C38 and C138 are selected from among the following capacitors.

.001 μ F	283-0067-00	200 V	$\pm 10\%$
.0015	283-0114-00	200 V	$\pm 20\%$
.0022	283-0119-00	200 V	$\pm 5\%$
.0027	283-0142-00	200 V	$\pm 5\%$
.0033	283-0041-00	500 V	$\pm 5\%$
.0047	283-0083-00	500 V	$\pm 5\%$
.01	283-0079-00	250 V	$\pm 20\%$

C264 is selected from among the following capacitors.

14 pF	281-0577-00	500 V	$\pm 5\%$
18 pF	281-0578-00	500 V	$\pm 5\%$
22 pF	281-0511-00	500 V	± 2.2 pF
27 pF	281-0512-00	500 V	± 2.7 pF
33 pF	281-0629-00	600 V	$\pm 5\%$
39 pF	281-0603-00	500 V	$\pm 5\%$
47 pF	281-0519-00	500 V	± 4.7 pF



a. Change the following control settings:

VOLTS/DIV (CH 1 and 2)	20 mV
MODE	CH 1
A and B TIME/DIV	.5 μ s

b. Connect the square-wave generator fast-rise + output to the Channel 1 INPUT connector through the five-nanosecond GR cable, 5 \times GR attenuator and 50-ohm in-line termination, in given order.

c. Set the square-wave generator for fast-rise operation and four-division display at 100 kilohertz.

d. CHECK—CRT display for optimum flat top (see Fig. 5-17A).

e. ADJUST—C263 and C265 (see Fig. 5-17C) for optimum flat top.

f. Change the following control settings:

A and B TIME/DIV	.2 μ s
MAG	$\times 10$

g. CHECK—CRT display for optimum square corner and flat top (see Fig. 5-17B).

NOTE

In the following steps, change the MAG switch from $\times 10$ to OFF and compare the response at both sweep rates. Then adjust for the best overall response.

h. ADJUST—R49, C49, R328, C336, C328, C54, and C45A, in given order, (see Fig. 5-17C and D) for optimum square corner and flat top. Repeat this adjustment until optimum high-frequency response is obtained (similar to Fig. 5-17B).

i. Set the MODE switch to CH 2.

j. Disconnect the 50-ohm in-line termination from the Channel 1 INPUT connector and connect it to the Channel 2 INPUT connector.

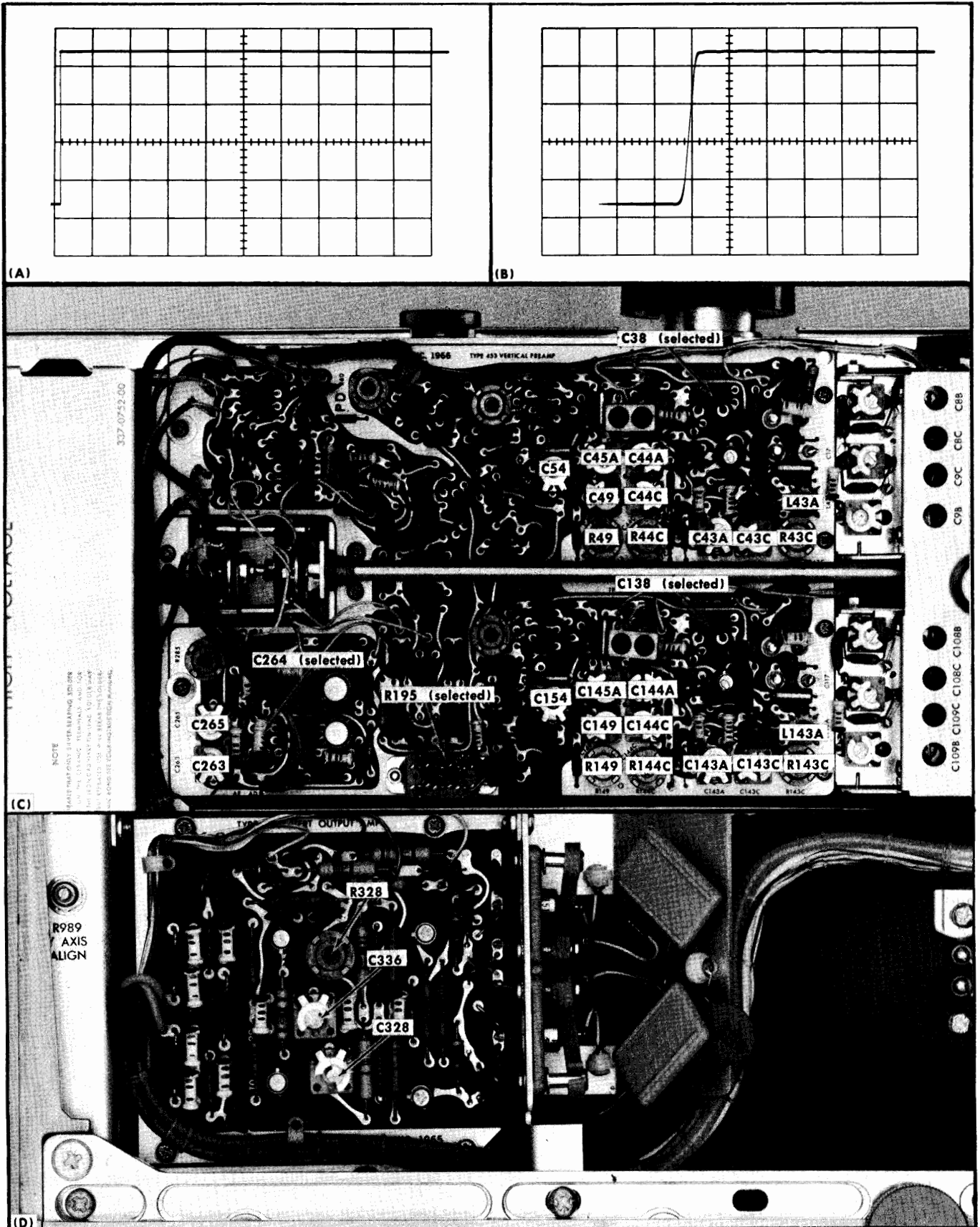

Fig. 5-17. (A) Typical CRT display showing correct high-frequency compensation (0.5 microseconds/division); (B) typical CRT display showing correct high-frequency compensation (10 microseconds/division); (C) location of high frequency compensation adjustments and selected components (Vertical Preamp circuit board); (D) location of R328, C328 and C336 (Vertical Output Amplifier circuit board).

Performance Check/Calibration—Type 453/R453

k. CHECK—CRT display for optimum square-wave response similar to Channel 1 response (see Fig. 5-17B).

l. ADJUST—R149, C149, C154, and C145A (see Fig. 5-17C) for optimum square-wave response similar to Channel 1 response. Repeat this adjustment until optimum response is obtained.

NOTE

If response of Channel 1 and 2 cannot be correctly matched using this adjustment procedure, see the procedure for reselecting R195 given in Table 5-4.

m. Set the CH 2 VOLTS/DIV switch to 10 mV.

n. Set the square-wave generator for a four-division display.

o. CHECK—CRT display for optimum square-wave response (see Fig. 5-17B).

p. ADJUST—R144C, C144C, and C144A, in given order, (see Fig. 5-17C) for optimum square-wave response. Repeat this adjustment until optimum response is obtained.

q. Set the CH 2 VOLTS/DIV switch to 5 mV.

r. Set the square-wave generator for a four-division display.

s. CHECK—CRT display for optimum square-wave response (see Fig. 5-17B).

t. ADJUST—R143C, C143C, C143A, and L143A (see Fig. 5-17C) for optimum square-wave response. Repeat this adjustment until optimum response is obtained.

u. Change the following control settings:

MODE	CH 1
CH 1 VOLTS/DIV	5 mV

v. Disconnect the 50-ohm in-line termination from the Channel 2 INPUT connector and connect it to the Channel 1 INPUT connector.

w. CHECK—CRT display for optimum square-wave response (see Fig. 5-17B).

x. ADJUST—R43C, C43C, C43A, and L43A (see Fig. 5-17C) for optimum square-wave response. Repeat this adjustment until optimum response is obtained.

y. Set the CH 1 VOLTS/DIV switch to 10 mV.

z. Set the square-wave generator for a four-division display.

aa. CHECK—CRT display for optimum square-wave response (see Fig. 5-17B).

ab. ADJUST—R44C, C44C, C44A, (see Fig. 5-17C) for optimum square-wave response. Repeat this adjustment until optimum response is obtained.

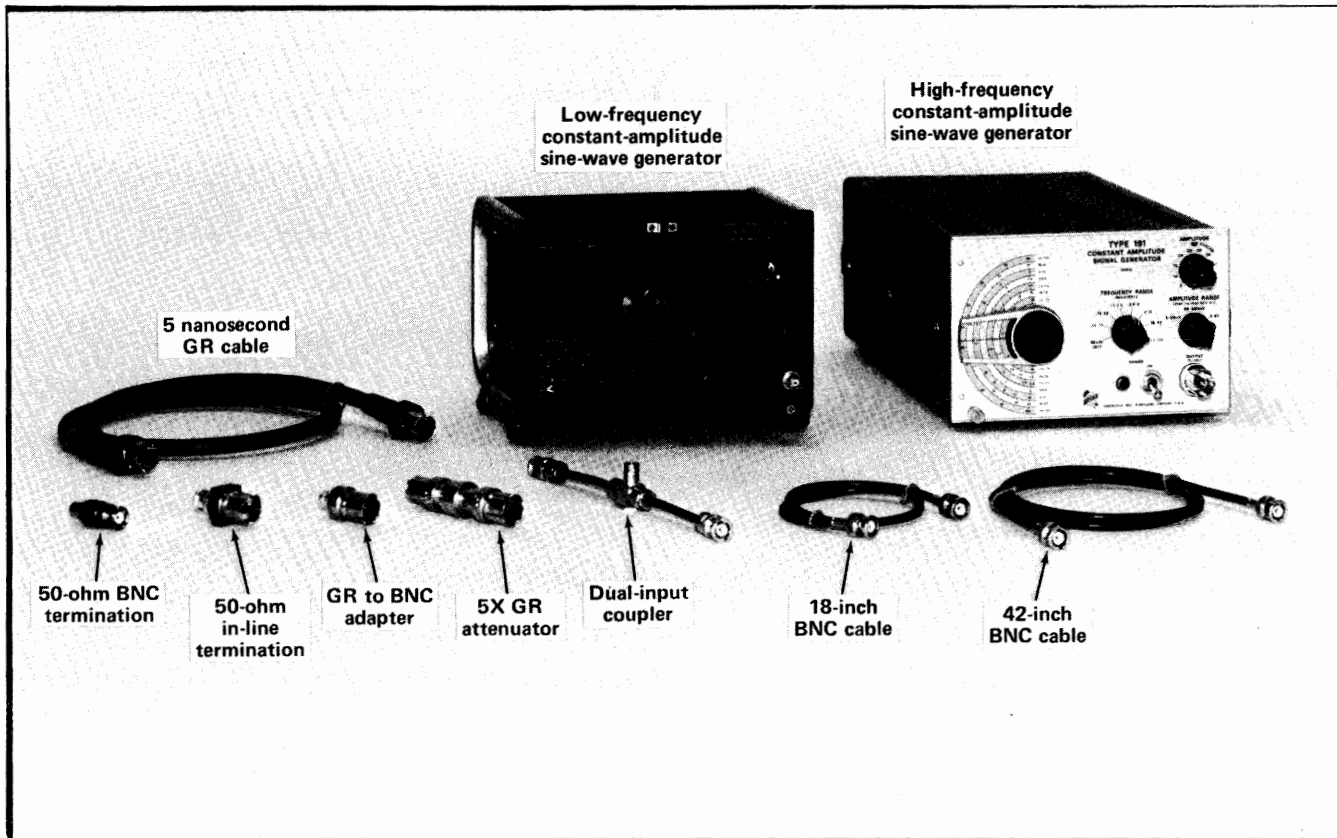

Fig. 5-18. Test equipment required for steps 25 through 40.

CONTROL SETTINGS

Set the controls as given under Preliminary Control Settings except as follows:

INTENSITY	Midrange
FOCUS	Adjust for a focused display
A and B TIME/DIV	20 μ s
A SWEEP MODE	AUTO TRIG

25. Check Upper Vertical Bandwidth Limit of Channel 1 and 2

a. Test equipment required for steps 25 through 40 is shown in Fig. 5-18.

b. Connect the constant-amplitude sine-wave generator (Type 191) to the Channel 1 INPUT connector through the five-nanosecond GR cable, 5 \times GR attenuator and the 50-ohm in-line termination.

c. Set the constant amplitude generator for a four-division display at its reference frequency (50 kHz).

d. Without changing the output amplitude, increase the output frequency of the generator until the deflection is reduced to 2.8 divisions (-3 dB point; see Fig. 5-19).

e. CHECK—Output frequency of generator must be 50 megahertz or higher.

f. Set the CH 1 VOLTS/DIV switch to 10 mV.

g. Set the constant-amplitude generator for a four division display at its reference frequency (50 kHz).

h. Without changing the output amplitude, increase the output frequency of the generator until the deflection is reduced to 2.8 divisions (-3 dB point; see Fig. 5-19).

i. CHECK—Output frequency of generator must be 45 megahertz or higher.

j. Set the CH 1 VOLTS/DIV switch to 5 mV.

k. Set the constant-amplitude generator for a four division display at its reference frequency (50 kHz).

l. Without changing the output amplitude, increase the output frequency of the generator until the deflection is reduced to 2.8 divisions (-3 dB point; see Fig. 5-19).

m. CHECK—Output frequency of generator must be 40 megahertz or higher.

n. Set the MODE switch to CH 2.

o. Disconnect the output of the in-line termination from the Channel 1 INPUT connector and connect it to the Channel 2 INPUT connector.

p. Set the constant-amplitude generator for a four-division display at its reference frequency (50 kHz).

q. Without changing the output amplitude, increase the output frequency of the generator until the deflection is reduced to 2.8 divisions (-3 dB point; see Fig. 5-19).

r. CHECK—Output frequency of generator must be 50 megahertz or higher.

s. Set the CH 2 VOLTS/DIV switch to 10 mV.

t. Set the constant-amplitude generator for a four-division display at its reference frequency (50 kHz).

u. Without changing the output amplitude, increase the output frequency of the generator until the deflection is reduced to 2.8 divisions (-3 dB point; see Fig. 5-19).

v. CHECK—Output frequency of generator must be 45 megahertz or higher.

w. Set the CH 2 VOLTS/DIV switch to 5 mV.

x. Set the constant-amplitude generator for a four-division display at its reference frequency (50 kHz).

y. Without changing the output amplitude, increase the output frequency of the generator until the deflection is reduced to 2.8 divisions (-3 dB point; see Fig. 5-19).

z. CHECK—Output frequency of generator must be 40 megahertz or higher.

26. Check Added Mode Upper Bandwidth Limit

a. Change the following control settings:

VOLTS/DIV (CH 1 and 2)	20 mV
CH 1 POSITION	Midrange
CH 1 Input Coupling	GND
MODE	ADD

b. Set the constant-amplitude generator for a four-division display at its reference frequency (50 kHz).

c. Without changing the output amplitude, increase the output frequency of the generator until the deflection is reduced to 2.8 divisions (-3 dB point; see Fig. 5-19).

d. CHECK—Output frequency of generator must be 50 megahertz or higher.

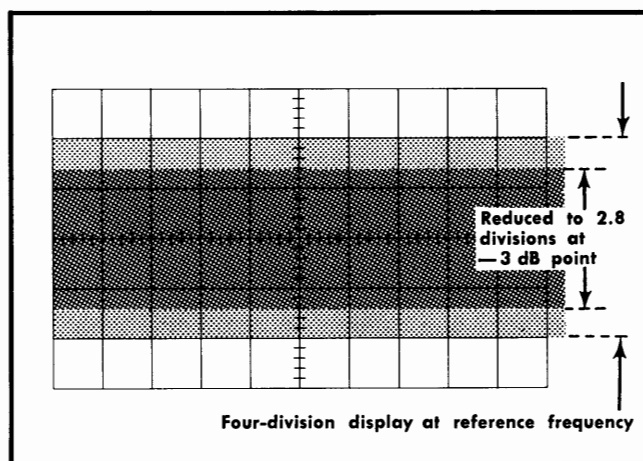

Fig. 5-19. Typical CRT display when checking vertical bandwidth (simulated waveform).

e. Change the following control settings:

CH 2 POSITION	Midrange
CH 1 Input Coupling	DC
CH 2 Input Coupling	GND

f. Disconnect the output of the in-line termination from the Channel 2 INPUT connector and connect it to the Channel 1 INPUT connector.

g. Set the constant-amplitude generator for a four division display at its reference frequency (50 kHz).

h. Without changing the output amplitude, increase the output frequency of the generator until the deflection is reduced to 2.8 divisions (−3 dB point; see Fig. 5-19).

i. CHECK—Output frequency of the generator must be 50 megahertz or higher.

27. Check Channel 1 and 2 Cascaded Upper Bandwidth Limit

a. Connect the CH 1 OUT connector to the Channel 2 INPUT connector with an 18-inch 50-ohm BNC cable.

b. Change the following control settings:

VOLTS/DIV	5 mV
MODE	CH 2
CH 2 Input Coupling	DC

c. Set the constant-amplitude generator for a four-division display at its reference frequency (50 kHz).

d. Without changing the output amplitude, increase the output frequency of the generator until the deflection is reduced to 2.8 divisions (−3 dB point; see Fig. 5-19).

e. CHECK—Output frequency of generator must be 25 megahertz or higher.

f. Disconnect the cable from between the CH 1 OUT and Channel 2 INPUT connector.

28. Check Common-Mode Rejection Ratio

a. Connect the constant-amplitude generator to the Channel 1 and 2 INPUT connectors through the five-nanosecond GR cable, 50-ohm in-line termination and the dual-input coupler.

b. Change the following control settings:

VOLTS/DIV (CH 1 and 2)	50 mV
------------------------	-------

c. Set the constant-amplitude generator for a 3.2 division display at 20 megahertz.

d. Change the following control settings:

VOLTS/DIV (CH 1 and 2)	20 mV
MODE	ADD
INVERT	Pulled Out

e. CHECK—CRT display for 0.4 division deflection, or less (common-mode rejection ratio 20:1 or better).

NOTE

This check applies only when the channel 1 and 2 gain is correctly adjusted as given in step 13. If the common-mode rejection ratio is lower than 20:1, check and readjust the gain. Then recheck this step. (Transistors Q43, Q54, Q143, and Q154 have the largest effect on common-mode rejection ratio.)

f. Disconnect the dual-input coupler.

29. Check Attenuator Isolation Ratio

a. Change the following control settings:

CH 1 VOLTS/DIV	1
CH 2 VOLTS/DIV	5 mV
CH 2 Input Coupling	GND
MODE	CH 1
INVERT	Pushed In

b. Connect the constant-amplitude generator to the Channel 1 INPUT connector through the five-nanosecond GR cable and the 50-ohm in-line termination.

c. Set the constant-amplitude generator for a five-division display at 20 megahertz (use the variable control of the generator, if necessary, to obtain a five-division display).

d. Set the MODE switch to CH 2.

e. CHECK—CRT display for 0.1-division deflection, or less (attenuator isolation ratio 10,000:1 or better).

f. Change the following control settings:

CH 1 VOLTS/DIV	5 mV
CH 2 VOLTS/DIV	1
CH 1 Input Coupling	GND
CH 2 INPUT Coupling	DC

g. Connect the constant-amplitude generator to the Channel 2 INPUT connector through the five-nanosecond GR cable and the 50-ohm in-line termination.

h. Set the constant-amplitude generator for a five-division display at 20 megahertz (use the variable control of the generator, if necessary, to obtain a five-division display).

i. Set the MODE switch to CH 1.

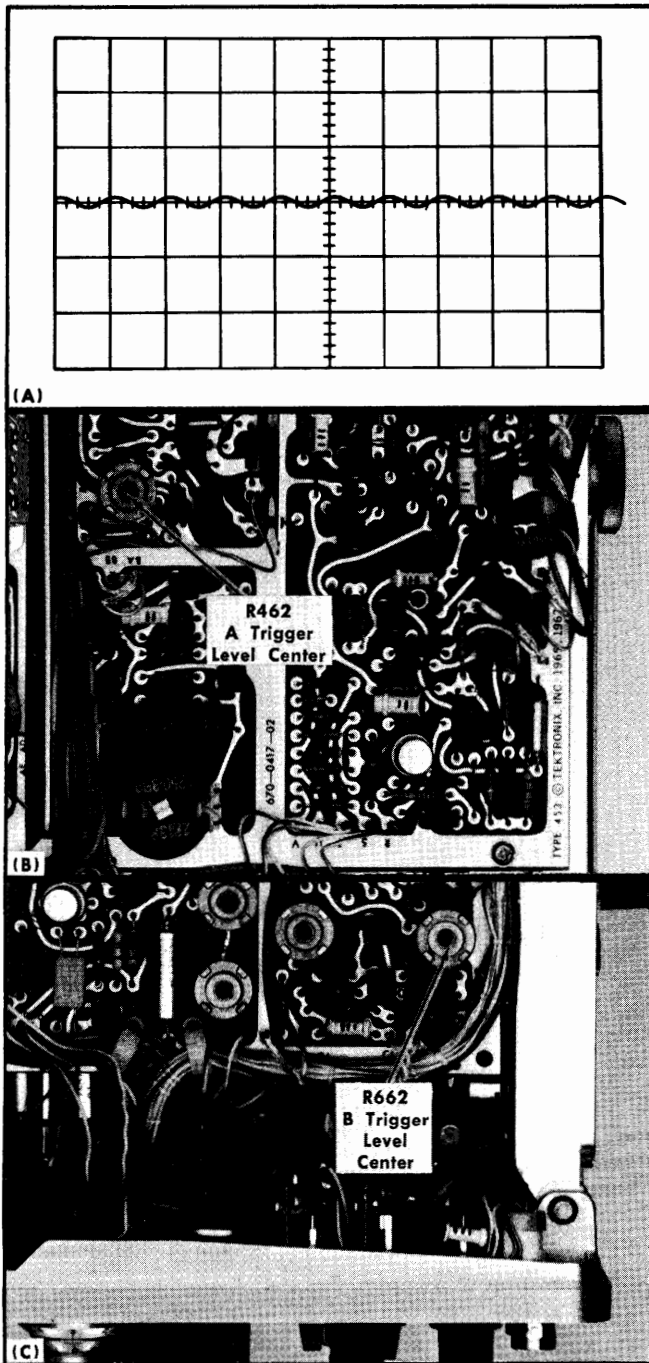

Fig. 5-20. (A) Typical CRT display when checking trigger level centering, (B) location of the A Trigger Level Center adjustment (A Sweep circuit board), (C) location of B Trigger Level Center adjustments of (B Sweep circuit board).

- j. CHECK—CRT display for 0.1-division deflection or less (attenuator isolation 10,000:1 or better; see Fig. 5-21).
- k. Disconnect all test equipment.

30. Check/Adjust A and B Trigger Level Centering

- a. Change the following control settings:

VOLTS/DIV (CH 1 and 2)	50 mV
Input Coupling (CH 1 and 2)	DC
LEVEL (Both A and B)	0
A and B TIME/DIV	20 μ s
A SWEEP MODE	NORM TRIGGER

b. Connect the constant-amplitude generator to the A EXT TRIG INPUT connector through the five-nanosecond GR cable, GR to BNC adapter and BNC T connector. Connect the output of the BNC T connector to the Channel 1 INPUT connector through an 18-inch 50-ohm BNC cable and a 50-ohm BNC termination.

c. Set the constant-amplitude generator for a 0.2-division display at 50 kilohertz (if necessary, use AUTO TRIG position to obtain 0.2-division display).

d. Be sure the A LEVEL control is set to 0.

e. CHECK—Stable CRT display (see Fig. 5-20A).

f. ADJUST—A Trigger Level Center adjustment, R462 (see Fig. 5-20B), for a stable display.

g. Set the HORIZ DISPLAY switch to A INTENS DURING B.

h. Be sure the B LEVEL control is set to 0.

i. CHECK—Stable CRT display (see Fig. 5-20A).

j. ADJUST—B Trigger Level Center adjustment, R662 (see Fig. 5-20C), for a stable display.

31. Check/Adjust Channel 1 Trigger DC Level and Normal Trigger DC Level

- a. Change the following control settings:

TRIGGER	CH 1 ONLY
A COUPLING	DC
A SWEEP MODE	AUTO TRIG
HORIZ DISPLAY	A

b. Move the trace to the center horizontal line with the CH 1 POSITION control.

c. CHECK—Stable CRT display. CH 1 light in both A and B Triggering must be on.

d. ADJUST—Channel 1 Trigger DC Level Adjustments, R60 (see Fig. 5-21), for a stable display.

e. CHECK—Stable CRT display.

f. Set the TRIGGER switch to NORM.

g. ADJUST—Normal Trigger DC Level adjustment, R285 (see Fig. 5-21), for a stable display.

32. Check A and B Internal Triggering Operation

a. Set the constant-amplitude generator for a 0.2-division display at 10 megahertz (use AUTO TRIG position, if necessary, to obtain display).

b. Set the A and B TIME/DIV switch to $.1 \mu\text{s}$.

c. CHECK—Stable CRT display (see Fig. 5-22A) can be obtained with the A COUPLING switch set to AC, LF REJ and DC (A LEVEL control may be adjusted as necessary to obtain stable display). The A SWEEP TRIG'D light must be on when the display is stable.

d. Set the constant-amplitude generator for a one-division display at 50 megahertz.

e. Set the MAG switch to $\times 10$.

f. CHECK—Stable CRT display (see Fig. 5-22B) can be obtained with the A COUPLING switch set to AC, LF REJ and DC (A LEVEL and HF STAB controls may be adjusted as necessary to obtain stable display). Display jitter should not exceed 0.1 division (one nanosecond).

g. Change the following control settings:

A LEVEL	Set for stable A display
HORIZ DISPLAY	DELAYED SWEEP (B)

h. Set the constant-amplitude generator for one-division display at 50 megahertz (as set in part d above).

i. CHECK—Stable CRT display (see Fig. 5-22B) can be obtained with the B COUPLING switch set to AC, LF REJ and DC (B LEVEL control may be adjusted as necessary to obtain stable display).

j. Set the constant-amplitude generator for a 0.2-division display at 10 megahertz.

k. Set the MAG switch to OFF.

l. CHECK—Stable CRT display (see Fig. 5-22A) can be obtained with the B COUPLING switch set to AC, LF REJ and DC (B LEVEL control may be adjusted as necessary to obtain a stable display).

33. Check A and B External Triggering Operation

a. Change the following control settings:

SOURCE (A and B)	EXT
HORIZ DISPLAY	A
MAG	OFF

b. Set the constant-amplitude generator for a one-division display (50 millivolts) at 10 megahertz.

c. CHECK—Stable CRT display (see Fig. 5-23A) can be obtained with the A COUPLING switch set to AC, LF REJ and DC (A LEVEL control may be adjusted as necessary to obtain stable display).

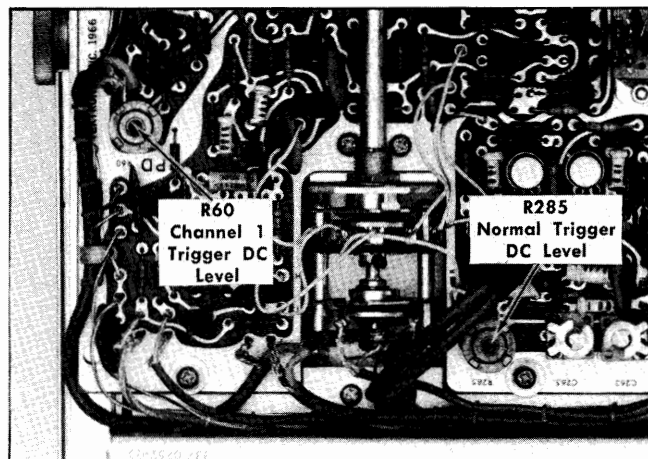

Fig. 5-21. Location of Channel 1 Trigger and Normal Trigger DC level (Vertical Preamp circuit board).

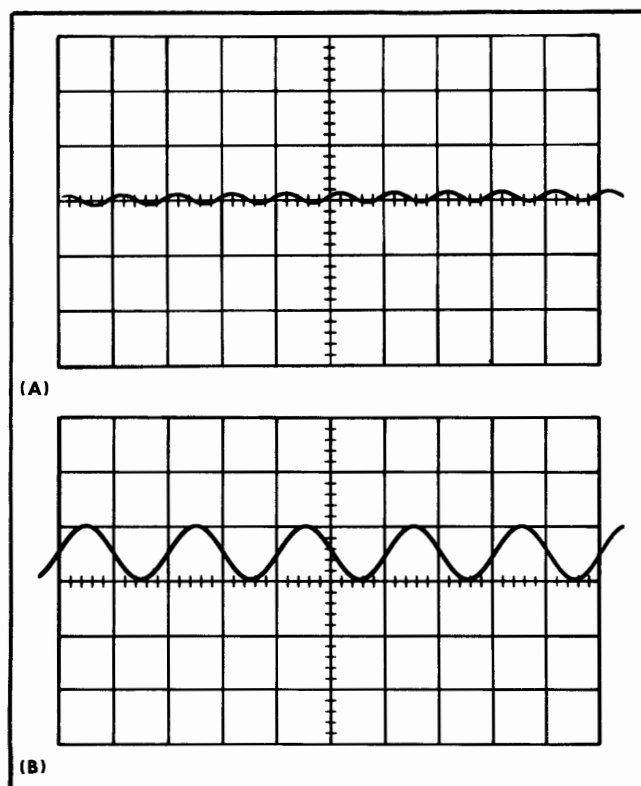

Fig. 5-22. (A) Typical CRT display when checking internal 10 megahertz triggering, (B) typical CRT display when checking internal 50 megahertz triggering.

d. Set the MAG switch to $\times 10$.

e. Set the constant-amplitude generator for a 2.8-division display at 50 megahertz (2.8-division display takes into account typical rolloff in vertical response at 50 MHz).

f. CHECK—Stable CRT display (see Fig. 5-23B) can be obtained with the A COUPLING switch set to AC, LF REJ and DC (A LEVEL and HF STAB controls may be adjusted as necessary to obtain stable display).

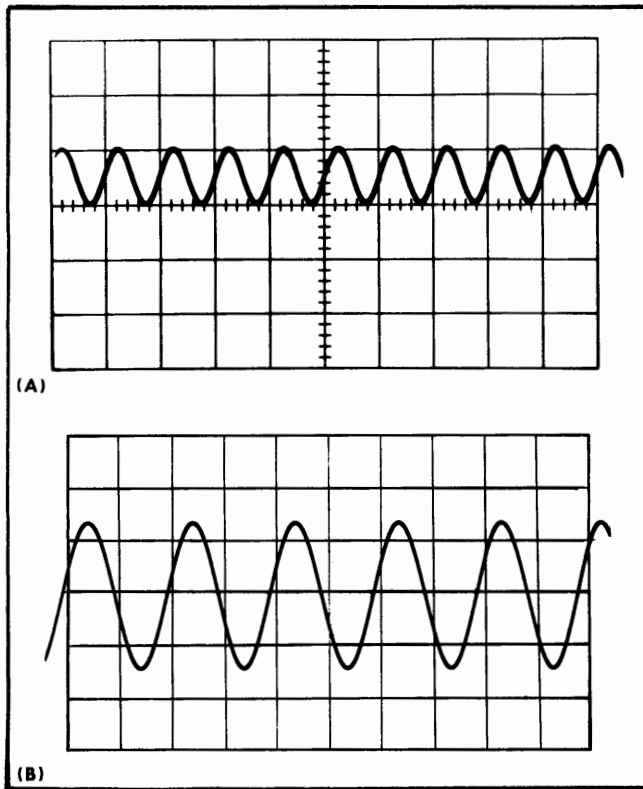

Fig. 5-23. (A) Typical CRT display when checking external 10 megahertz triggering, (B) typical CRT display when checking external 50 megahertz triggering.

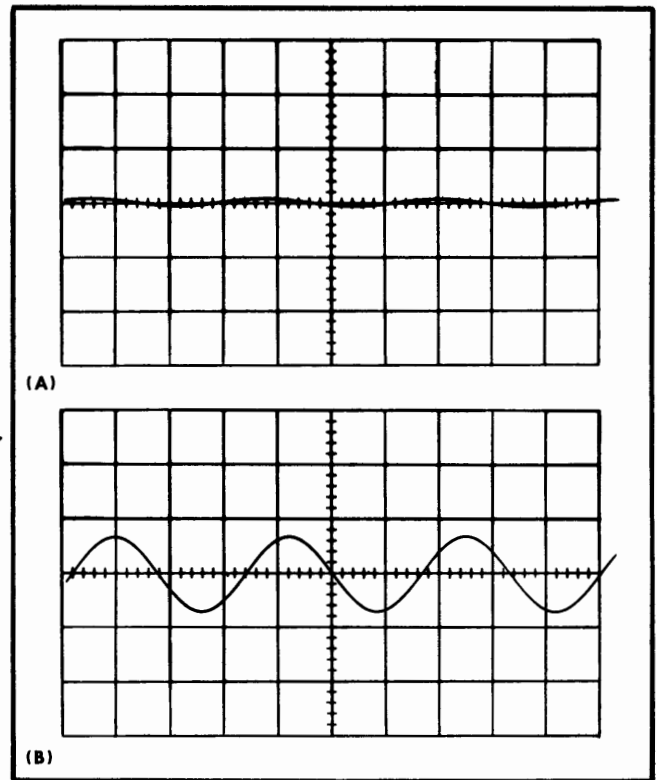

Fig. 5-24. (A) Typical CRT display when checking internal low-frequency triggering at 60 hertz, (B) typical CRT display when checking external low-frequency triggering at 60 hertz.

g. Disconnect the constant-amplitude generator signal from the A EXT TRIG INPUT connector and reconnect it to the B EXT TRIG INPUT connector.

h. Change the following control settings:

A SOURCE	INT
A LEVEL	Set for stable A display
HORIZ DISPLAY	DELAYED SWEEP (B)

i. CHECK—Stable CRT display (see Fig. 5-23B) can be obtained with the B COUPLING switch set to AC, LF REJ and DC (B LEVEL control may be adjusted as necessary to obtain stable display).

j. Set the MAG switch to OFF.

k. Set the constant-amplitude generator for a one-division display at 10 megahertz.

l. CHECK—Stable CRT display (see Fig. 5-23A) can be obtained with the B COUPLING switch set to AC, LF REJ and DC (B LEVEL control may be adjusted as necessary to obtain stable display).

m. Disconnect all test equipment.

34. Check A and B Low-Frequency Triggering Operation

a. Connect the low-frequency constant-amplitude generator to the A EXT TRIG INPUT connector through a 50-ohm

BNC cable and the BNC T connector. Connect the output of the BNC T connector to the Channel 1 INPUT connector through an 18-inch 50-ohm BNC cable and a 50-ohm BNC termination.

b. Change the following control settings:

A and B TIME/DIV	5 ms
HORIZ DISPLAY	A

c. Set the low-frequency generator for a 0.2-division display at 60 hertz.

d. CHECK—Stable CRT display (see Fig. 5-24A) can be obtained with the A COUPLING switch set to AC, HF REJ and DC (A LEVEL control may be adjusted as necessary to obtain stable display).

e. Set the A and B SOURCE switches to EXT.

f. Set the low-frequency generator for a one-division display at 60-hertz (50 millivolts).

g. CHECK—Stable CRT display (see Fig. 5-24B) can be obtained with the A COUPLING switch set to AC, HF REJ and DC (A LEVEL control may be adjusted as necessary to obtain stable display).

h. Change the following control settings:

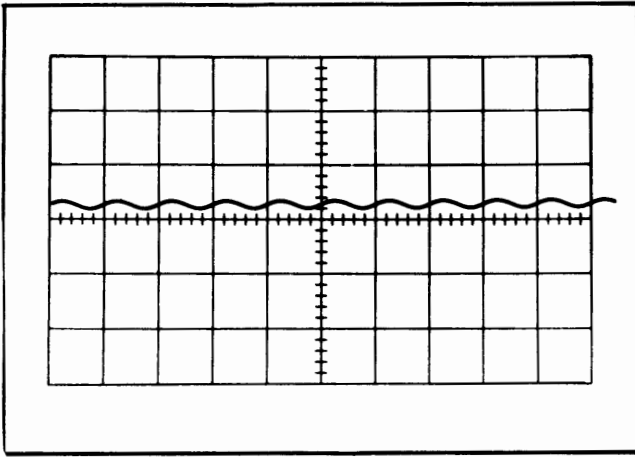

Fig. 5-25. Typical CRT display when checking high-frequency reject operation at 50 kilohertz.

A SOURCE	INT
A LEVEL	Set for stable A display
HORIZ DISPLAY	DELAYED SWEEP (B)

i. Disconnect the low-frequency generator from the A EXT TRIG INPUT connector and reconnect it to the B EXT TRIG INPUT connector.

j. CHECK—Stable CRT display (see Fig. 5-24B) can be obtained with the B COUPLING switch set to AC, HF REJ and DC (B LEVEL control may be adjusted as necessary to obtain stable display).

k. Set the B SOURCE switch to INT.

l. Set the low-frequency generator for a 0.2 division display at 60 hertz.

m. CHECK—Stable CRT display (see Fig. 5-24A) can be obtained with the B COUPLING switch set to AC, HF REJ and DC (B LEVEL control may be adjusted as necessary to obtain stable display).

35. Check A and B High-Frequency Reject Operation

a. Change the following control settings:

COUPLING (A and B)	HF REJ
A and B TIME/DIV	20 μ s
A SWEEP MODE	AUTO TRIG

b. Set the low-frequency constant-amplitude generator for a 0.2-division display at 50 kilohertz.

c. CHECK—Stable CRT display (see Fig. 5-25) can be obtained with the B LEVEL control.

d. Without changing the output amplitude, set the low-frequency generator to one megahertz.

e. Set the MAG switch to $\times 10$.

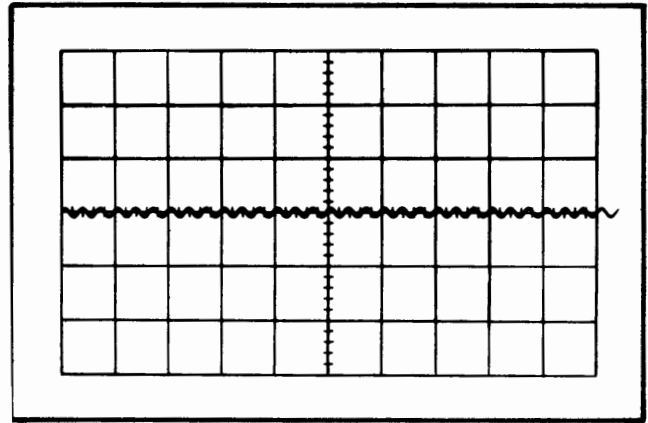

Fig. 5-26. Typical CRT display when checking low-frequency reject operation at 30 kilohertz.

f. CHECK—Stable display cannot be obtained at any setting of the B LEVEL control.

g. Change the following control settings:

A SWEEP MODE	NORM TRIG
HORIZ DISPLAY	A
MAG	OFF

h. Set the low-frequency generator for a 0.2-division display at 50 kilohertz.

i. CHECK—Stable CRT display (see Fig. 5-25) can be obtained with the A LEVEL control.

j. Without changing the output amplitude, set the constant-amplitude generator to one megahertz.

k. Set the MAG switch to $\times 10$.

l. CHECK—Stable display cannot be obtained at any setting of the A LEVEL control.

36. Check A and B Low-Frequency Reject Operation

a. Set the low-frequency generator for a 0.2-division display at 30 kilohertz.

b. Change the following control settings:

COUPLING (A and B)	LF REJ
A and B TIME/DIV	.1 ms
MAG	OFF

c. CHECK—Stable CRT display (see Fig. 5-26) can be obtained with the A LEVEL control.

d. Without changing the output amplitude, set the low-frequency generator to 60 hertz.

e. Set the A and B TIME/DIV switch to 2 ms.

f. CHECK—Stable CRT display cannot be obtained at any setting of the A LEVEL control.

Performance Check/Calibration—Type 453/R453

g. Change the following control setting:

A and B TIME/DIV	.1 ms
A SWEEP MODE	AUTO TRIG
HORIZ DISPLAY	DELAYED SWEEP (B)

h. Set the low-frequency generator for a 0.2-division display at 30 kilohertz (as set in part a of this step).

i. CHECK—Stable CRT display (see Fig. 5-26) can be obtained with the B LEVEL control.

j. Without changing the output amplitude, set the low-frequency generator to 60 hertz.

k. Set the A and B TIME/DIV switch to 2 ms.

l. CHECK—Stable CRT display cannot be obtained at any setting of the B LEVEL control.

37. Check Single Sweep Operation

a. Change the following control settings:

COUPLING (A and B)	AC
A and B TIME/DIV	5 ms
HORIZ DISPLAY	A

b. Set the low-frequency generator for a five-division display at one kilohertz.

c. Set the A LEVEL control fully clockwise.

d. Set the A SWEEP MODE switch to SINGLE SWEEP.

e. Push the RESET button.

f. CHECK—RESET light must come on when button is pressed and remain on until sweep is triggered.

g. Slowly rotate the A LEVEL control counterclockwise.

h. CHECK—A single-sweep display (one sweep only) is presented when the A LEVEL control is in the triggerable region. RESET light must go off at the end of the sweep and remain off until the RESET button is pressed again.

38. Check A and B Slope Switch Operation

a. Change the following control settings:

A LEVEL	0
A SWEEP MODE	NORM TRIG

b. Set the low-frequency generator for a four-division display at one kilohertz.

c. CHECK—CRT display starts on the positive slope of the waveform (see Fig. 5-27A).

d. Set the A SLOPE switch to —.

e. CHECK—CRT display starts on the negative slope of the waveform (see Fig. 5-27B).

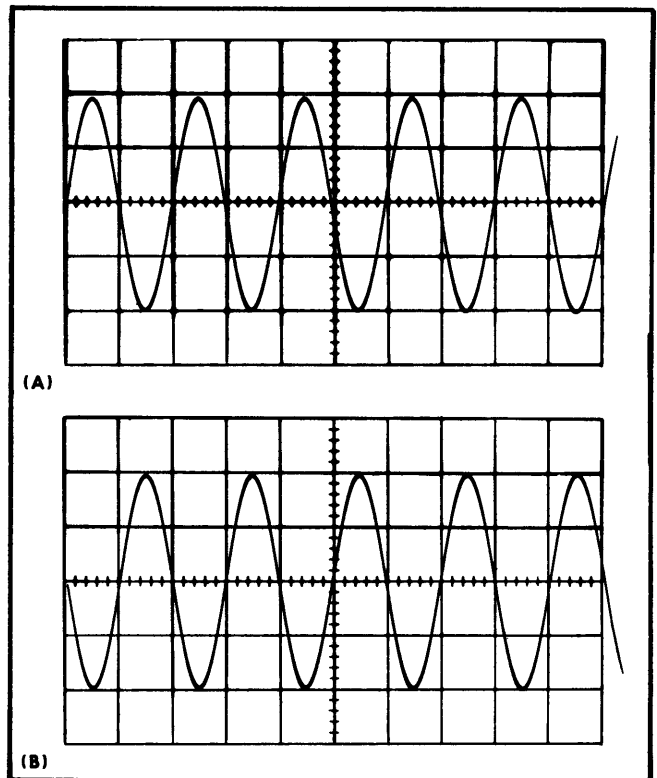

Fig. 5-27. Typical CRT display when checking slope switch operation.

f. Set the A SWEEP MODE switch to AUTO TRIG.

g. Set the HORIZ DISPLAY switch to DELAYED SWEEP (B).

h. CHECK—CRT display starts on the positive slope of the waveform (see Fig. 5-27A).

i. Set the B SLOPE switch to —.

j. CHECK—CRT display starts on the negative slope of the waveform (see Fig. 5-27B).

k. Disconnect all test equipment.

39. Check A and B Level Control Range

a. Connect the low-frequency generator to the B EXT TRIG INPUT connector through a 42-inch BNC cable and the BNC T connector. Connect the output of the BNC T connector to the Channel 1 INPUT connector through an 18-inch BNC cable.

b. Change the following control settings:

CH 1 VOLTS/DIV	1
COUPLING (A and B)	DC
LEVEL (A and B)	Midrange
B SOURCE	EXT

c. Set the low-frequency generator for a four-division display (four volts peak to peak) at one kilohertz.

d. CHECK—Rotate the B LEVEL control throughout its range and check that display can be triggered (stable display) at any point along the negative slope of the waveform (indicates B LEVEL control range of at least + and — two volts). Display is not triggered at either extreme of rotation.

e. Set the B SLOPE switch to +.

f. CHECK—Rotate the B LEVEL control throughout its range and check that display can be triggered at any point along the positive slope of the waveform. Display is not triggered at either extreme of rotation.

g. Set the CH 1 VOLTS/DIV switch to 10.

h. Set the B SOURCE switch to EXT $\div 10$.

i. Set the low-frequency generator for a four-division display (40 volts peak to peak) at one kilohertz.

j. CHECK—Rotate the B LEVEL control throughout its range and check that display can be triggered at any point along the positive slope of the waveform (indicates B LEVEL control range of at least + and — 20 volts). Display is not triggered at either extreme of rotation.

k. Set the B SLOPE switch to —.

l. CHECK—Rotate the B LEVEL control throughout its range and check that display can be triggered at any point along the negative slope of the waveform. Display is not triggered at either extreme of rotation.

m. Change the following control settings:

A SOURCE	EXT $\div 10$
A SWEEP MODE	NORM TRIG
HORIZ DISPLAY	A

n. Disconnect the low-frequency generator from the B EXT TRIG INPUT connector and reconnect it to the A EXT TRIG INPUT connector.

o. CHECK—Rotate the A LEVEL control throughout its range and check that display can be triggered at any point along the negative slope of the waveform (indicates A LEVEL control range of at least + and — 20 volts). Display is not triggered at either extreme of rotation.

p. Set the A SLOPE switch to +.

q. CHECK—Rotate the A LEVEL control throughout its range and check that display can be triggered at any point along the positive slope of the waveform. Display is not triggered at either extreme of rotation.

r. Change the following control settings:

CH 1 VOLTS/DIV	1
A SOURCE	EXT

s. Set the low-frequency generator for a four-division display (four volts peak to peak) at one kilohertz.

t. CHECK—Rotate the A LEVEL control throughout its range and check that display can be triggered at any point along the positive slope of the waveform (indicates A LEVEL control range of at least + and — two volts). Display is not triggered at either extreme of rotation.

u. Set the A SLOPE switch to —.

v. CHECK— Rotate the A LEVEL control throughout its range and check that display can be triggered at any point along the negative slope of the waveform. Display is not triggered at either extreme of rotation.

w. Disconnect all test equipment.

40. Check A and B Line Triggering Operation

a. Connect the 10 \times probe to the Channel 1 INPUT connector.

b. Change the following control settings:

CH 1 VOLTS/DIV	10
SOURCE (A and B)	LINE
A and B TIME/DIV	2 ms

c. Connect the probe tip to the same line-voltage source which is connected to this instrument.

d. CHECK—Stable CRT display triggered on the correct slope.

e. Set the HORIZ DISPLAY switch to DELAYED SWEEP (B).

f. CHECK—Stable CRT display triggered on the correct slope.

g. Disconnect all test equipment.

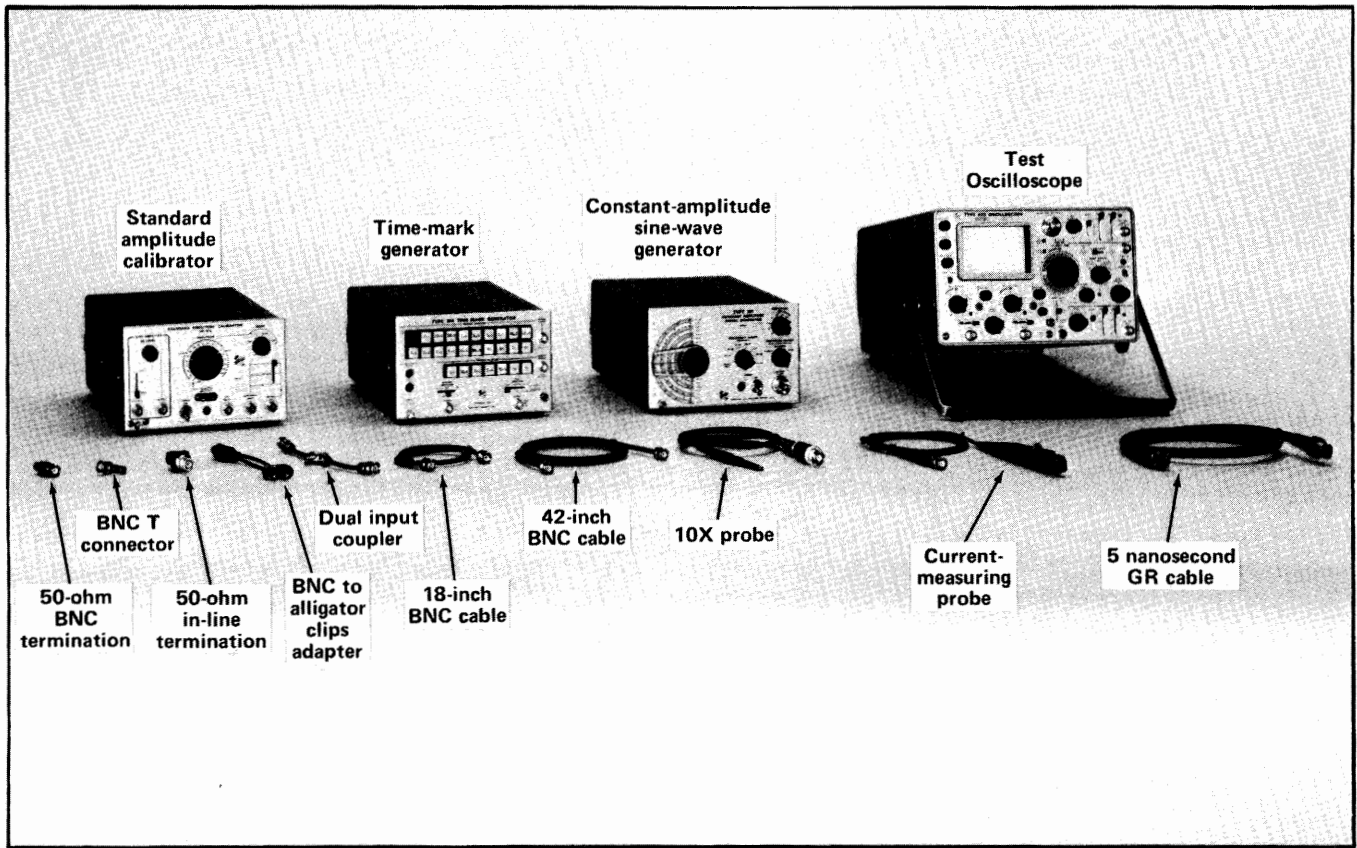

Fig. 5-28. Test equipment required for steps 41 through 74.

CONTROL SETTINGS

Set the controls as given under Preliminary Control Settings except as follows:

VOLTS/DIV (CH 1 and 2)	.2
LEVEL (A)	Stable Display
A and B TIME/DIV	50 μ s
A SWEEP MODE	AUTO TRIG
B SWEEP MODE	B STARTS AFTER DELAY-TIME
SOURCE (A and B)	INTERNAL

41. Check Auto Recovery Time and Operation

- Test equipment required for steps 41 through 74 is shown in Fig. 5-28.
- Connect the time-mark generator to the Channel 1 INPUT connector through the 42-inch 50-ohm BNC cable and 50-ohm BNC termination.
- Set the time-mark generator for 50-millisecond markers.

CAUTION

To prevent permanent damage to the CRT phosphor at low rates, position the baseline of the marker display below the viewing area.

- CHECK—Stable display can be obtained with the A LEVEL control. Marker must be at the start of the sweep.

- Set the time-mark generator for 0.1-second markers.

- CHECK—Sweep free runs and stable display cannot be obtained. If stable display is obtained, marker must not be at the start of the sweep.

42. Check/Adjust Sweep Start and A Sweep Calibration

- Change the following control settings:

A TIME/DIV	1 ms
B TIME/DIV	5 μ s
HORIZ DISPLAY	A INTEN DURING B

- Turn the DELAY-TIME MULTIPLIER dial fully counterclockwise.

- CHECK—DELAY-TIME MULTIPLIER dial setting 0.20.

- ADJUST—If the DELAY-TIME MULTIPLIER dial is not correctly positioned when fully counterclockwise, loosen the set screw and reposition the dial at 0.20.

- Repeat parts b through d until the DELAY-TIME MULTIPLIER dial is correctly positioned at 0.20.

- Set the time-mark generator for one-millisecond markers.

- Set the DELAY-TIME MULTIPLIER dial to 1.00.

- CHECK—Intensified portion of display starts at second marker (see Fig. 5-29A).

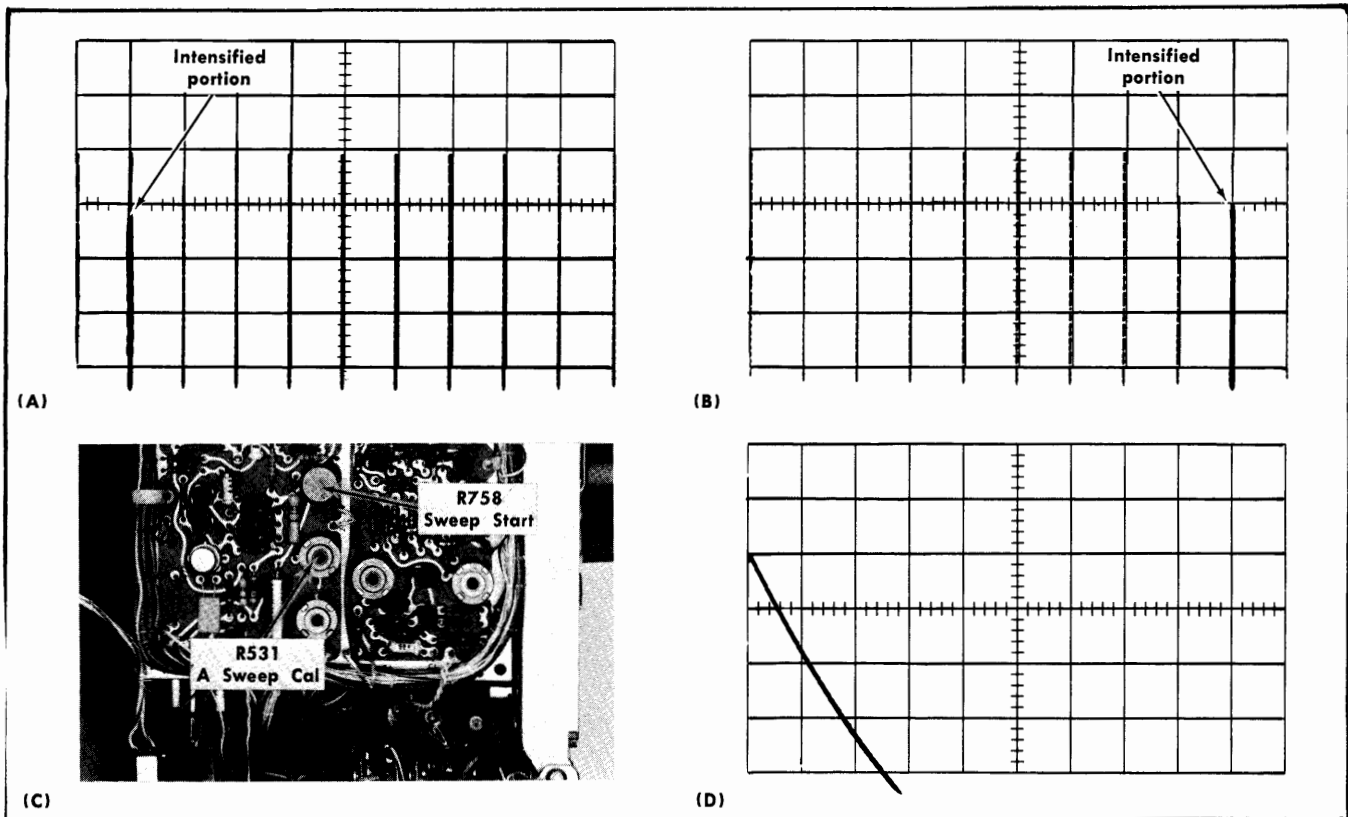

Fig. 5-29. (A) Typical CRT display showing intensified portion correctly located at the second marker, (B) typical CRT display showing intensified portion correctly located at the tenth marker, (C) location of Sweep Start and A Sweep Cal adjustments (B Sweep board), (D) typical CRT display showing correct final adjustment of Sweep Start and A Sweep Cal adjustments.

i. ADJUST—Sweep Start adjustment, R758 (see Fig. 5-29C), so intensified portion starts at second marker (preliminary adjustment).

j. Set DELAY-TIME MULTIPLIER dial to 9.00.

k. CHECK—Intensified portion of display starts at tenth marker (see Fig. 5-29B).

l. ADJUST—A Sweep Cal adjustment, R531 (see Fig. 5-29C), so intensified portion starts at tenth marker (preliminary adjustment).

m. Set the HORIZ DISPLAY switch to DELAYED SWEEP (B).

n. Set the DELAY-TIME MULTIPLIER dial to 1.00.

o. CHECK—Displayed pulse starts at the beginning of the sweep (see Fig. 5-29D).

p. ADJUST—Sweep Start adjustment, R758 (see Fig. 5-29C), so displayed pulse starts at the beginning of the sweep.

q. Set DELAY-TIME MULTIPLIER dial to 9.00.

r. CHECK—Displayed pulse starts at the beginning of the sweep (see Fig. 5-29D).

s. ADJUST—A Sweep Cal adjustment, R531 (see Fig. 5-29C), so displayed pulse starts at the beginning of the sweep.

t. Recheck parts n through s and readjust if necessary.

43. Check/Adjust Normal Gain

a. Set the HORIZ DISPLAY switch to A.

b. CHECK—CRT display for one marker each division, $\pm 3\%$, between the first- and ninth-division vertical lines (see Fig. 5-30A).

NOTE

Unless otherwise noted, use the middle eight horizontal divisions when checking or adjusting timing.

c. ADJUST—Normal Gain adjustment, R835 (see Fig. 5-30B), for one marker each division. The second and tenth markers must coincide exactly with their respective graticule lines (reposition the display slightly with the horizontal POSITION control if necessary).

d. INTERACTION—Check steps 44 through 59.

44. Check/Adjust Magnified Gain

a. Set the time-mark generator for 0.1 millisecond markers.

b. Set the MAG switch to $\times 10$.

c. CHECK—CRT display for one marker each division, $\pm 4\%$, between the first and ninth graticule lines (see Fig. 5-31A).

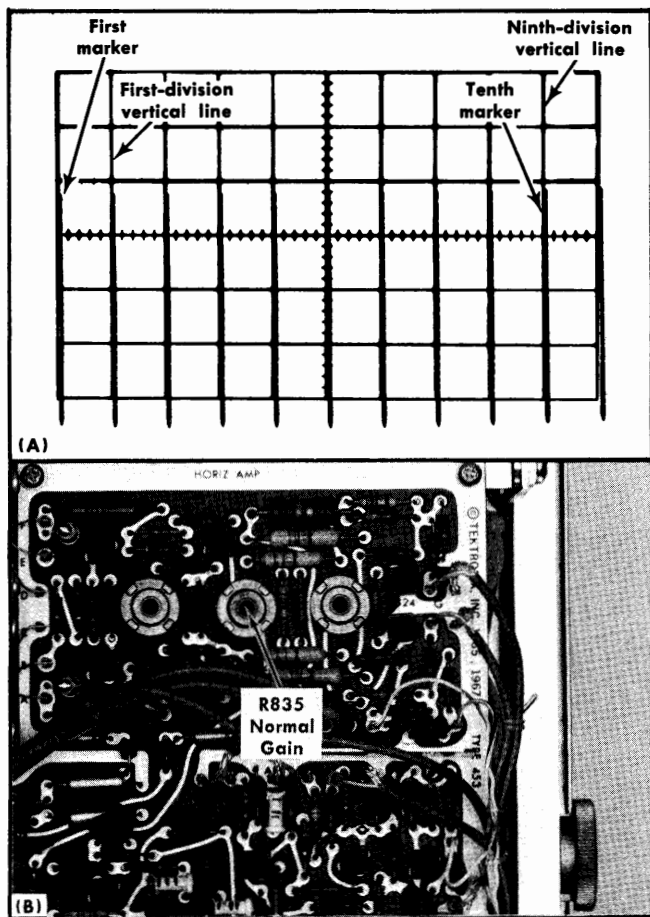

Fig. 5-30. (A) Typical CRT display showing correct normal gain; (B) location of Normal Gain adjustment (B sweep circuit board).

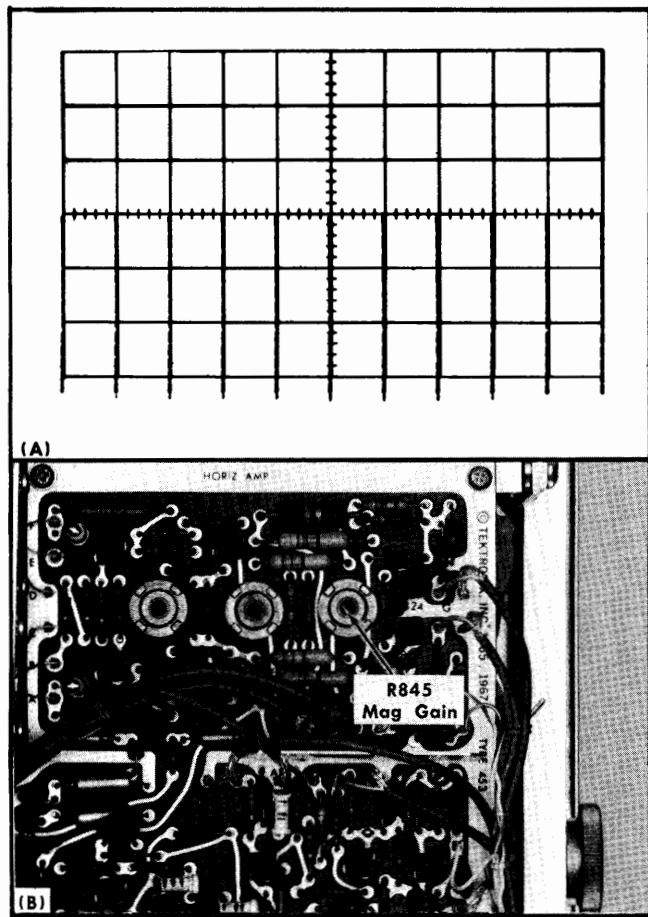

Fig. 5-31. (A) Typical CRT display showing correct magnified gain; (B) location of Mag Gain adjustment (B Sweep circuit board).

d. ADJUST—Mag Gain adjustment, R845, (see Fig. 5-31B), for one marker each division. The second and tenth markers must coincide exactly with their respective graticule lines (reposition the display slightly with the horizontal FINE control if necessary).

e. Position the first eight-division portion of the total magnified sweep onto the viewing area.

f. CHECK—One marker each division between the first- and ninth-division vertical lines; marker at ninth-division vertical line must be within 0.12 division (within 1.5%) of the line when the marker at the first-division vertical line is positioned exactly.

g. Repeat this check for each eight division portion of the total magnified sweep length.

h. INTERACTION—Check steps 45, 53, 55, and 57.

45. Check/Adjust Magnifier Register ❶

a. Set the time-mark generator for five-millisecond markers.

b. Position the middle marker (three markers on total magnified sweep) to the center vertical line (see Fig. 5-32A).

- c. Set the MAG switch to OFF.
- d. CHECK—Middle marker should remain at the center vertical line (see Fig. 5-32B), ± 0.2 division.
- e. ADJUST—Mag Register adjustment, R855 (see Fig. 5-32C), to position the middle marker to the center vertical line.
- f. Set the MAG switch to $\times 10$.
- g. Repeat parts b through e until no shift occurs when MAG switch is set to OFF.

46. Check/Adjust B Sweep Calibration ❶

- a. Change the following control settings:
- | | |
|-----------------------|------------------------------|
| DELAY-TIME MULTIPLIER | Fully Counterclockwise |
| A TIME/DIV | 2 ms |
| B TIME/DIV | 1 ms |
| B SWEEP MODE | TRIGGERABLE AFTER DELAY TIME |
| HORIZ DISPLAY | DELAYED SWEEP (B) |
| MAG | OFF |

b. Set the time-mark generator for one-millisecond markers.

c. Set the B LEVEL control for a stable display.

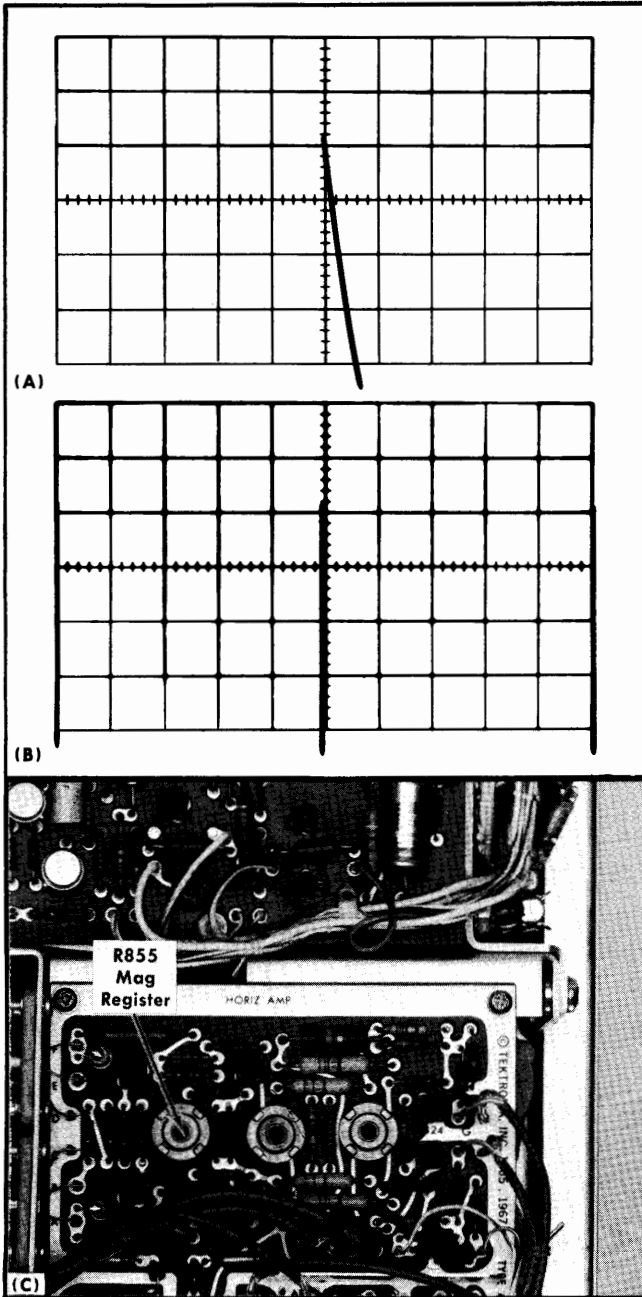

Fig. 5-32. Typical CRT display showing correct magnifier register. (A) MAG switch to $\times 10$, (B) MAG switch set to OFF, (C) location of Mag Register adjustment (B Sweep circuit board).

d. CHECK—CRT display for one marker each division between the first- and ninth-division vertical lines (see Fig. 5-33A).

e. ADJUST—B Sweep Cal adjustment, R741 (see Fig. 5-33B).

f. INTERACTION—Check steps 51 and 56.

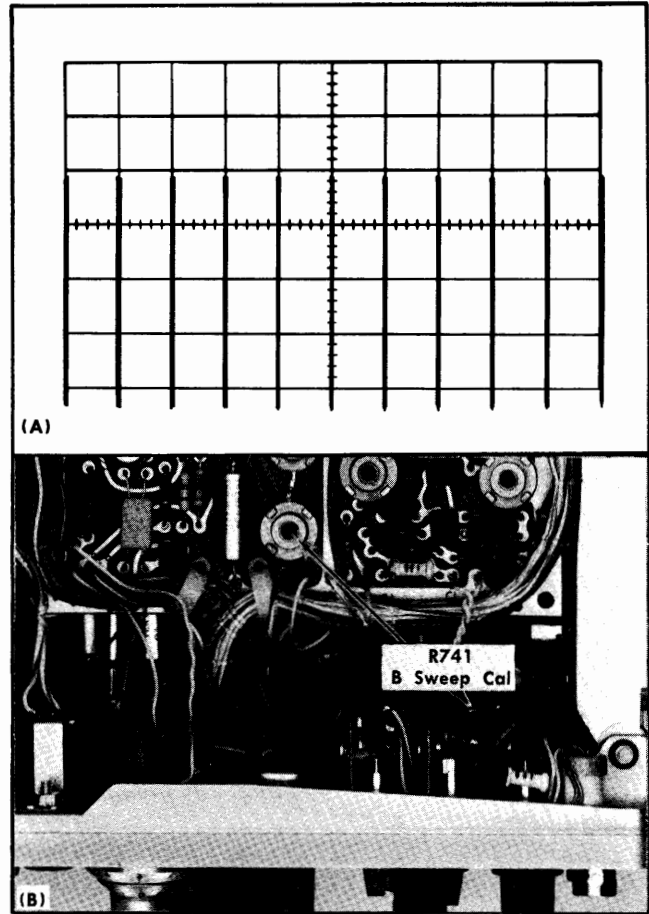

Fig. 5-33. (A) Typical CRT display showing correct B Sweep calibration, (B) location of the B Sweep Cal adjustment of (B Sweep circuit board).

47. Check B Sweep Length

a. Set the time-mark generator for 1- and 0.1-millisecond markers.

b. Move the eleventh large marker to the center vertical line with the horizontal POSITION control (see Fig. 5-34).

c. CHECK—B Sweep length must be between 10.5 and 11.5 divisions, as shown by 0.5 to 1.5 divisions of display to the right of the center vertical line (see Fig. 5-34). Large markers indicate divisions and small markers indicate 0.1 division.

48. Check A Sweep Length

a. Set the HORIZ DISPLAY switch to A.

b. Set the A TIME/DIV switch to 1 ms.

c. Move the eleventh marker to the center vertical line with the horizontal POSITION control (see Fig. 5-34).

d. CHECK—A Sweep length must be between 10.5 and 11.5 divisions as shown by 0.5 and 1.5 divisions of display to the right of the center vertical line.

Performance Check/Calibration—Type 453/R453

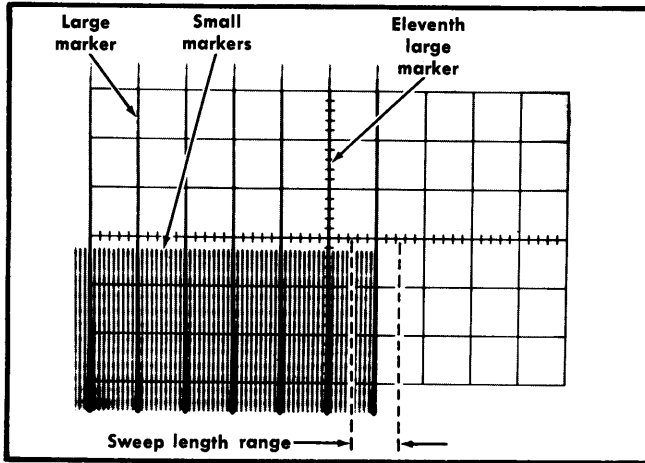

Fig. 5-34. Typical CRT display when checking A and B sweep length.

- e. Reposition the first marker to the left graticule line.
- f. Turn the A SWEEP LENGTH control to 4 DIV (not in B ENDS A detent).
- g. CHECK—A Sweep length must be four divisions or less.

49. Check B Ends A Operation

- a. Change the following control settings:

B TIME/DIV	.1 ms
B SWEEP MODE	B STARTS AFTER DELAY TIME
HORIZ DISPLAY	A INTEN DURING B
A SWEEP LENGTH	B ENDS A
- b. Rotate the DELAY-TIME MULTIPLIER dial throughout its range.
- c. CHECK—CRT display ends after the intensified portion at all DELAY-TIME MULTIPLIER dial settings.

50. Check A Variable Control Range

- a. Change the following control settings:

DELAY-TIME MULTIPLIER	Fully Counterclockwise
B TIME/DIV	1 ms
HORIZ DISPLAY	A
A SWEEP LENGTH	FULL
- b. Set the time-mark generator for 10-millisecond markers.
- c. Position the markers to the far left and right graticule lines with the horizontal POSITION control.
- d. Turn the A VARIABLE control fully counterclockwise.
- e. CHECK—CRT display for four-division maximum spacing between markers (indicates adequate range for continuously variable sweep rates between the calibrated steps; see Fig. 5-35). UNCAL A OR B light must be on when A VARIABLE control is not in CAL position.

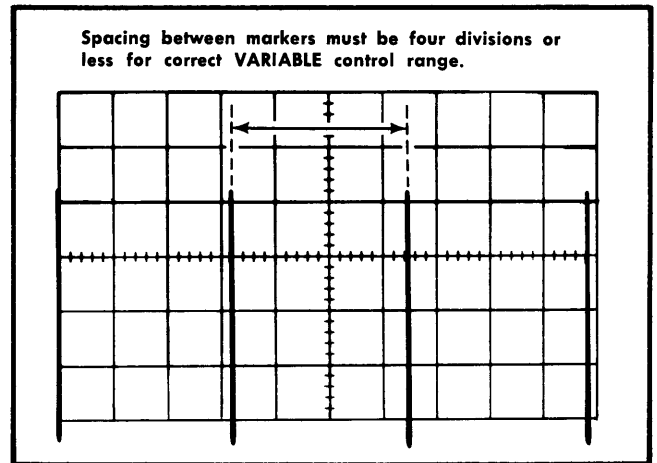

Fig. 5-35. Typical CRT display when checking A and B VARIABLE control range.

51. Check B Variable Control Range

- a. Change the following control settings:

A TIME/DIV	5 ms
B TIME/DIV	1 ms
A VARIABLE	CAL
B SWEEP MODE	TRIGGERABLE AFTER DELAY TIME
HORIZ DISPLAY	DELAYED SWEEP (B)
- b. Position markers to the far left and right vertical lines of the graticule with the horizontal POSITION control.
- c. Turn the B TIME/DIV VARIABLE control fully counterclockwise.
- d. CHECK—CRT display for four-division maximum spacing between markers (indicates adequate range for continuously variable sweep rate between the calibrated steps; see Fig. 5-35). UNCAL A OR B light must be on when B TIME/DIV VARIABLE control is not in CAL position.

52. Check/Adjust One-Microsecond Timing

- a. Change the following control settings:

A and B TIME/DIV	1 μ s
HORIZ DISPLAY	A
B TIME/DIV VARIABLE	CAL
- b. Set the time-mark generator for one-microsecond markers.
- c. CHECK—CRT display for one marker each division, $\pm 3\%$, between the first- and ninth-division vertical lines (see Fig. 5-36A).
- d. ADJUST—C530A (see Fig. 5-36B) for one marker each division.

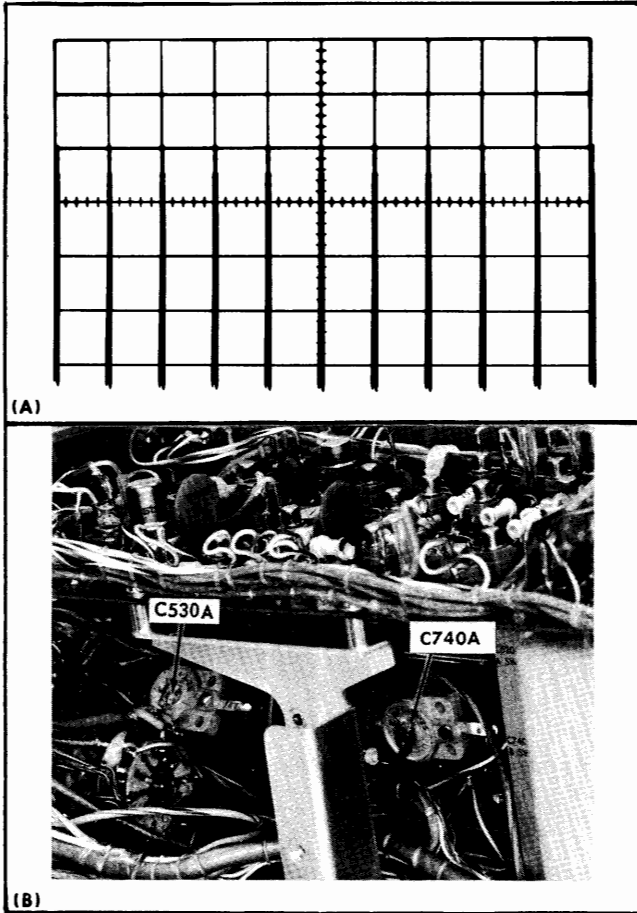

Fig. 5-36. Typical CRT display showing correct one-microsecond timing, (B) location of C530A and C740A (behind swing-out side panel).

- e. Set the HORIZ DISPLAY switch to DELAYED SWEEP (B).
- f. CHECK—CRT display for one marker each division, $\pm 3\%$, between the first- and ninth-division vertical lines (see Fig. 5-36A).
- g. ADJUST—C740A (see Fig. 5-36B) for one marker each division.

53. Check/Adjust High-Speed Linearity ❶

- a. Change the following control settings:

CH 1 VOLTS/DIV	20 mV
A and B TIME/DIV	.1 μ s
HORIZ DISPLAY	A
- b. Set the time-mark generator for 10-nanosecond markers.
- c. Position the display horizontally so the sweep starts at the left edge of the graticule.
- d. Set the MAG switch to $\times 10$.
- e. CHECK—CRT display for optimum linearity over the center eight divisions of the graticule (see Fig. 5-37A).

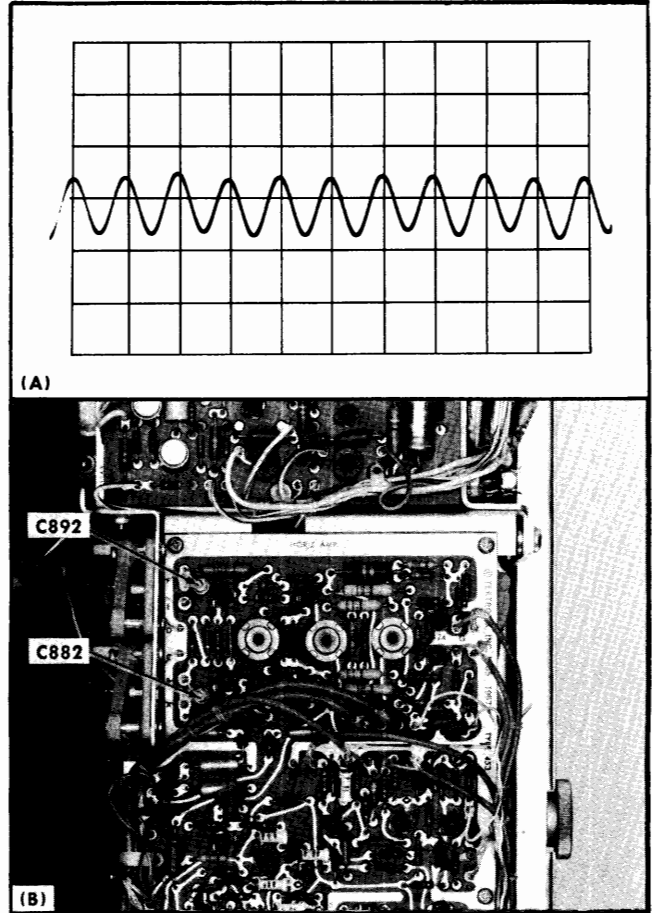

Fig. 5-37. (A) Typical CRT display showing correct high speed linearity, (B) location of C882 and C892 (B Sweep circuit board).

- f. ADJUST—C882 and C892 (see Fig. 5-37B) for optimum linearity over the center eight divisions of the graticule (attempt to keep C882 and C892 nearly equal in capacitance by adjusting each capacitor about the same amount).

54. Check A Sweep Timing Accuracy

- a. Change the following control settings:

CH 1 VOLTS/DIV	.2
MAG	OFF
- b. CHECK—Using the A TIME/DIV switch and time-mark generator settings given in Table 5-5, check A sweep timing within 0.24 division, over the middle eight divisions of the display (within 3%).

CAUTION

To prevent possible burning of the CRT phosphor at slow sweep rates, position the baseline of the marker display below the viewing area.

TABLE 5-5
A and B Timing Accuracy

A and B TIME/DIV Switch Setting	Time-Mark Generator Output	CRT Display (markers/division)
.1 μ s	0.1 microsecond	1
.2 μ s	0.1 microsecond	2
.5 μ s	0.5 microsecond	1
1 μ s	1 microsecond	1
2 μ s	1 microsecond	2
5 μ s	5 microsecond	1
10 μ s	10 microsecond	1
20 μ s	10 microsecond	2
50 μ s	50 microsecond	1
.1 ms	0.1 millisecond	1
.2 ms	0.1 millisecond	2
.5 ms	0.5 millisecond	1
1 ms	1 millisecond	1
2 ms	1 millisecond	2
5 ms	5 millisecond	1
10 ms	10 millisecond	1
20 ms	10 millisecond	2
50 ms	50 millisecond	1
.1 s	0.1 second	1
.2 s	0.1 second	2
.5 s	0.5 second	1
A Sweep Only		
1 s	1 second	1
2 s	1 second	2
5 s	5 second	1

55. Check A Magnified Sweep Accuracy

- a. Set the MAG switch to $\times 10$.
- b. CHECK—Using the A TIME/DIV switch and time-mark generator settings given in Table 5-6, check A magnified sweep timing within 0.32 divisions over the middle eight divisions of the magnified display (within 4%). Note the portion of the total magnified sweep length to be excluded from the measurement. Magnifier light must be on.

56. Check B Sweep Timing Accuracy

- a. Set the MAG switch to OFF.
- b. Set the HORIZ DISPLAY switch to DELAYED SWEEP (B).
- c. CHECK—Using the A and B TIME/DIV switch and time-mark generator settings given in Table 5-5, check B sweep timing within 0.24 division over the middle eight divisions of the display (within 3%).

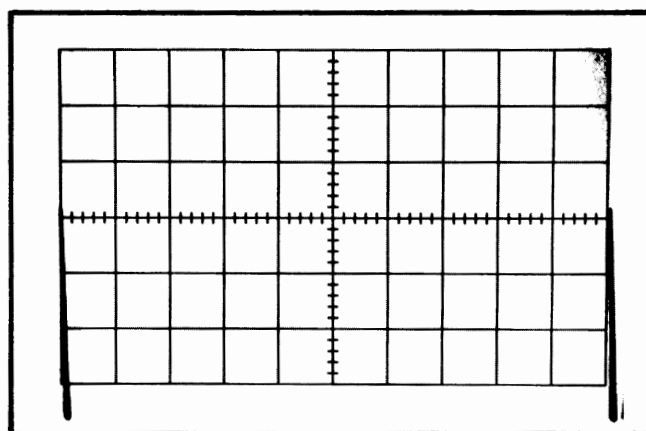

Fig. 5-38. Typical CRT display when checking delayed-sweep accuracy.

57. Check B Magnified Sweep Accuracy

- a. Set the MAG switch to $\times 10$.
- b. CHECK—Using the A and B TIME/DIV switch and time-mark generator settings given in Table 5-6, check B magnified sweep timing within 0.32 division over the middle eight divisions of the magnified display (within 4%). Note the portions of the total magnified sweep length to be excluded from the measurements.

58. Check Delay-Time Accuracy

- a. Set the MAG switch to OFF.
- b. Set the B SWEEP MODE switch to B STARTS AFTER DELAY TIME.
- c. CHECK—Using the A TIME/DIV switch, B TIME/DIV switch and time-mark generator settings given in Table 5-7, check delayed sweep accuracy within the given tolerance. First set the DELAY-TIME MULTIPLIER dial to 1.00 and rotate the dial until the sweep starts at the top of the second marker (see Fig. 5-38). Note the dial reading and then set the dial to 9.00 and rotate until the sweep starts at the top of the tenth marker. DELAY-TIME MULTIPLIER dial setting must be 8.00 divisions higher, + or— the allowable error given in Table 5-7.

NOTE

Sweep will start at top of third marker at 1.00, and nineteenth marker at 9.00 for sweep rates which are multiples of 2 (e.g., 2 μ s, 20 μ s, .2 ms, etc). If in doubt as to the correct setting of the DELAY-TIME MULTIPLIER dial, set the HORIZ DISPLAY switch to A INTEN DURING B and check which marker is intensified.

TABLE 5-6
A and B Magnified Accuracy

A and B TIME/DIV Switch Setting	Time-mark Generator Output	CRT Display (markers/division)	Portions of total magnified sweep length to exclude from measurement
.1 μ s	10 nanosecond	1	First and last three divisions.
.2 μ s	10 nanosecond	2	First and last 3.5 divisions.
.5 μ s	50 nanosecond	1	First two divisions.
1 μ s	0.1 microsecond	1	First division.
2 μ s	0.1 microsecond	2	
5 μ s	0.5 microsecond	1	
10 μ s	1 microsecond	1	
20 μ s	1 microsecond	2	
50 μ s	5 microsecond	1	
.1 ms	10 microsecond	1	
.2 ms	10 microsecond	2	
.5 ms	50 microsecond	1	
1 ms	0.1 millisecond	1	
2 ms	0.1 millisecond	2	
5 ms	0.5 millisecond	1	
10 ms	1 millisecond	1	
20 ms	1 millisecond	2	
50 ms	5 millisecond	1	
.1 s	10 millisecond	1	
.2 s	10 millisecond	2	
.5 s	50 millisecond	1	
A Sweep Only			
1 s	0.1 second	1	
2 s	0.1 second	2	
5 s	0.5 second	1	

59. Check Delay-Time Multiplier Incremental Linearity

a. Change the following control settings:

DELAY-TIME MULTIPLIER 9.00

A TIME/DIV 1 ms

B TIME/DIV 5 μ s

b. Set the time-mark generator for one-millisecond markers.

c. Rotate the dial as necessary to position the start of the pulse to the beginning of the sweep (see Fig. 5-39).

d. CHECK—Deviation of dial reading from 9.00 should be within two minor dial divisions ($\pm 0.2\%$).

NOTE

A sweep must be correctly calibrated to check this step to the given accuracy.

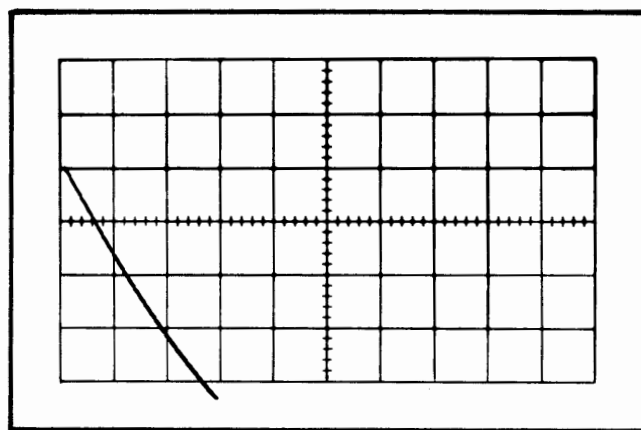

Fig. 5-39. Typical CRT display when checking DELAY-TIME MULTIPLIER incremental linearity.

TABLE 5-7
Delayed Sweep Accuracy

A TIME/DIV Switch Setting	B TIME/DIV Switch Setting	Time-Mark Generator Output	Allowable error for given accuracy
1 μ s	.1 μ s	1 microsecond	±12 minor dial divisions (±1.5% over center eight divisions)
2 μ s	.1 μ s	1 microsecond	
5 μ s	.5 μ s	5 microsecond	
10 μ s	1 μ s	10 microsecond	
20 μ s	1 μ s	10 microsecond	
50 μ s	5 μ s	50 microsecond	
.1 ms	10 μ s	0.1 millisecond	
.2 ms	10 μ s	0.1 millisecond	
.5 ms	50 μ s	0.5 millisecond	
1 ms	.1 ms	1 millisecond	
2 ms	.1 ms	1 millisecond	
5 ms	.5 ms	5 millisecond	
10 ms	1 ms	10 millisecond	
20 ms	1 ms	10 millisecond	
50 ms	5 ms	50 millisecond	
.1 s	10 ms	0.1 second	
.2 s	10 ms	0.1 second	
.5 s	50 ms	0.5 second	
1 s	.1 s	1 second	
2 s	.1 s	1 second	
5 s	.5 s	5 second	

e. Repeat check at each major dial division between 9.00 and 1.00.

60. Check Delay-Time Jitter

a. Change the following control settings:

DELAY-TIME MULTIPLIER 1.00
B TIME/DIV 1 μ s

b. Position the pulse near the center of the display area with the DELAY-TIME MULTIPLIER dial.

c. CHECK—Jitter on the leading edge of the pulse should not exceed 0.5 division (one part in 20,000; see Fig. 5-40). Disregard slow drift.

d. Turn the DELAY-TIME MULTIPLIER dial to 9.00 and adjust so the pulse is displayed near the center of the display area.

e. CHECK— Jitter on the leading edge of the pulse should not exceed 0.5 division (see Fig. 5-40). Disregard slow drift.

f. Disconnect all test equipment.

61. Check/Adjust External Horizontal Gain

a. Connect the standard amplitude calibrator to the Channel 1 INPUT connector through the 42-inch BNC cable.

b. Set the standard amplitude calibrator for a 0.1-volt square-wave output.

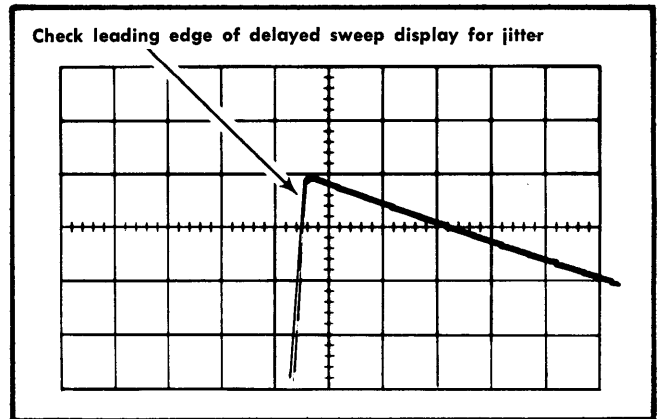

Fig. 5-40. Typical CRT display when checking delay-time jitter.

c. Change the following control settings:

VOLTS/DIV (CH 1 and CH 2)	20 mV
MODE	CH 2
TRIGGER	CH 1 ONLY
COUPLING (A and B)	DC
HORIZ DISPLAY	EXT HORIZ

d. Increase the INTENSITY control setting until the display is visible (two dots about five divisions apart).

e. Move the display to the center of the graticule with the Channel 1 POSITION control.

f. CHECK—CRT display for five divisions ± 0.25 division horizontal deflection.

g. ADJUST—Ext Horiz Gain adjustment, R645 (see Fig. 5-41B), for five divisions horizontal deflection.

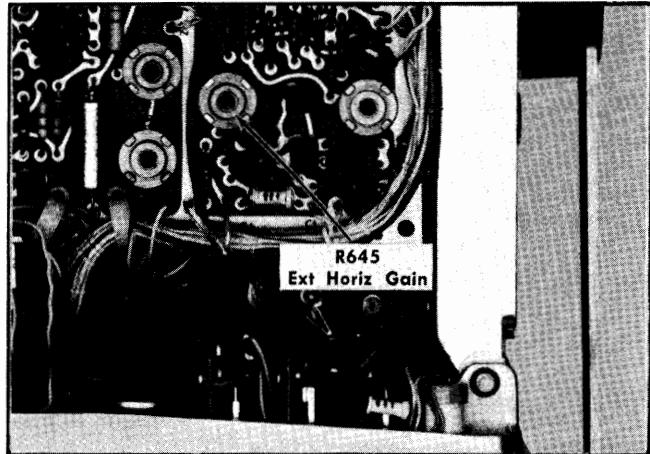

Fig. 5-41. Location of Ext Horiz Gain adjustment (B Sweep circuit board).

62. Check External Horizontal Operation

a. Set the B SOURCE switch to EXT.

b. Connect the standard amplitude calibrator to the EXT HORIZ input connector (B EXT TRIG INPUT).

c. Set the standard amplitude calibrator for a two-volt square-wave output.

d. CHECK—CRT display for horizontal deflection between 6.5 and 8.7 divisions (270 millivolts/division, $\pm 15\%$).

e. Set the standard amplitude calibrator for a 20-volt square-wave output.

f. Set the B SOURCE switch to EXT $\div 10$.

g. CHECK—CRT display for horizontal deflection between 6.2 and 9.2 divisions (2.7 volts/division, $\pm 20\%$).

h. Disconnect all test equipment.

63. Check X-Y Phasing

a. Connect the constant-amplitude sine wave generator to the Channel 1 and 2 INPUT connectors through the five-nanosecond GR cable, 50-ohm in-line termination and the dual-input coupler.

b. Change the following control settings:

CH 1 VOLTS/DIV	10 mV
CH 2 VOLTS/DIV	50 mV
B SOURCE	INT

c. Set the medium-frequency generator for a 10-division horizontal display at 50 kilohertz.

d. Center the display vertically and horizontally with the Channel 1 and 2 POSITION controls.

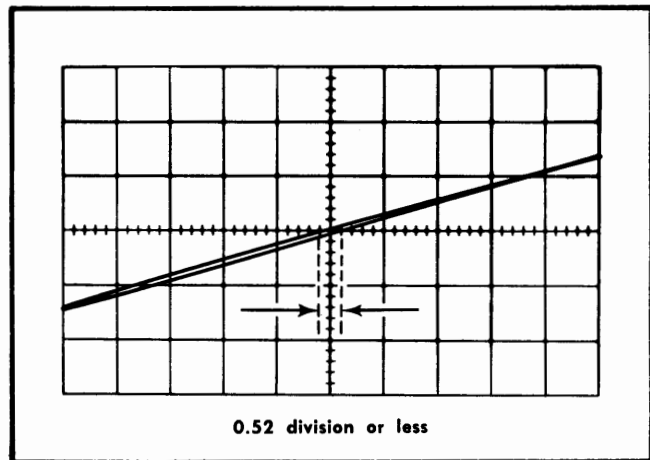

Fig. 5-42. Typical CRT display when checking X-Y phasing.

e. CHECK—CRT display for an opening at the center horizontal line of 0.52 division or less (3° or less phase shift; see Fig. 5-42).

64. Check X Bandwidth in External Horizontal Mode

a. Disconnect the dual-input coupler from the Channel 2 INPUT connector.

b. Set the medium-frequency generator for a six-division horizontal display at its reference frequency (50 kHz).

c. Without changing the output amplitude, increase the output frequency of the generator until the horizontal deflection is reduced to 4.3 divisions (-3 dB point; see Fig. 5-43).

d. CHECK—Output frequency of generator must be five megahertz or higher.

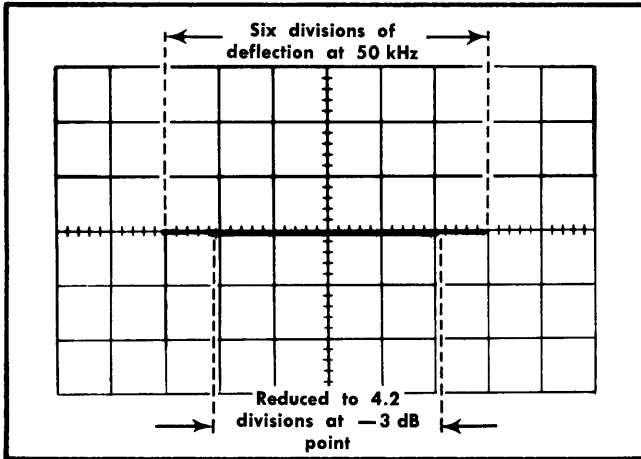

Fig. 5-43. Typical CRT display when checking external horizontal bandwidth (double exposure).

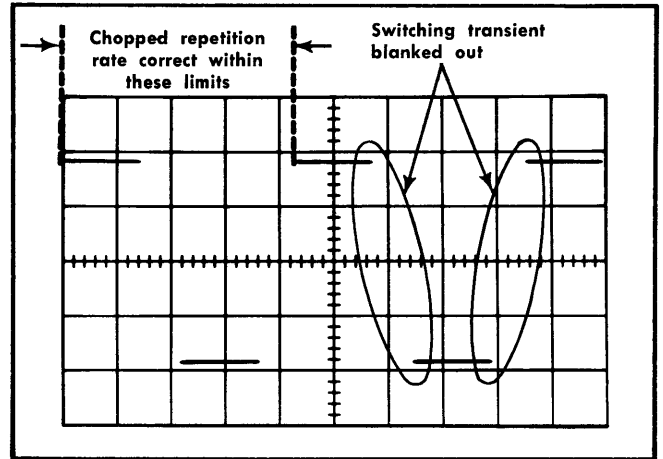

Fig. 5-44. Typical CRT display when checking chopped repetition rate and blanking.

65. Check Trace Finder Operation

- Reconnect the dual-input coupler to the Channel 2 INPUT connector.
- While holding the TRACE FINDER button depressed, rotate the Channel 1, Channel 2 and Horizontal POSITION controls and the CH 1 and CH 2 VOLTS/DIV switches throughout their ranges.
- CHECK—CRT display remains within the graticule area.
- While holding the TRACE FINDER button depressed, adjust the positioning controls until the display is centered about the graticule center lines. Then, increase the X and Y deflection factors until the display is reduced to about two divisions vertically and about four divisions horizontally.
- Release the TRACE FINDER button.
- CHECK—CRT display must remain within the graticule area.
- Reduce the INTENSITY control to a normal setting (about midrange).
- Disconnect all test equipment.

66. Check Chopped Operation

- Change the following control settings:

MODE	CHOP
TRIGGER	NORM
A and B TIME/DIV	.5 μ s
HORIZ DISPLAY	A
- Position the traces about four divisions apart.
- Set the A LEVEL control for a stable display.
- CHECK—Each cycle for duration of 3.4 to 5 divisions (500 kilohertz, $\pm 20\%$; see Fig. 5-44).
- CHECK—CRT display for complete blanking of switching transients between chopped segments (see Fig. 5-44).

67. Check/Adjust Calibrator Repetition Rate

- Connect the 1 kHz CAL connector to the Channel 1 INPUT connector with an 18-inch BNC cable.
- Connect the time-mark generator to the Channel 2 INPUT connector with a 42-inch BNC cable.
- Set the time-mark generator for one-millisecond markers.
- Change the following control settings:

CH 1 VOLTS/DIV	50 mV
CH 2 VOLTS/DIV	.2
MODE	ALT
A and B TIME/DIV	1 ms
- Set the A LEVEL control for a stable display.
- Position the display so the tips of the markers fall just below the rising portions of the square wave (see Fig. 5-45A).
- CHECK—For one cycle of calibrator waveform for each marker (see Fig. 5-45A).
- ADJUST—Calibrator Frequency adjustment, T1255 (see Fig. 5-45B), for one cycle of calibrator waveform for each marker (preliminary adjustment).
- Set the TRIGGER switch to CH 1 ONLY.
- CHECK—CRT display for slow drift or no drift of the time markers.
- ADJUST—T1255 for minimum drift of time markers (final adjustment).
- Disconnect the time-mark generator.

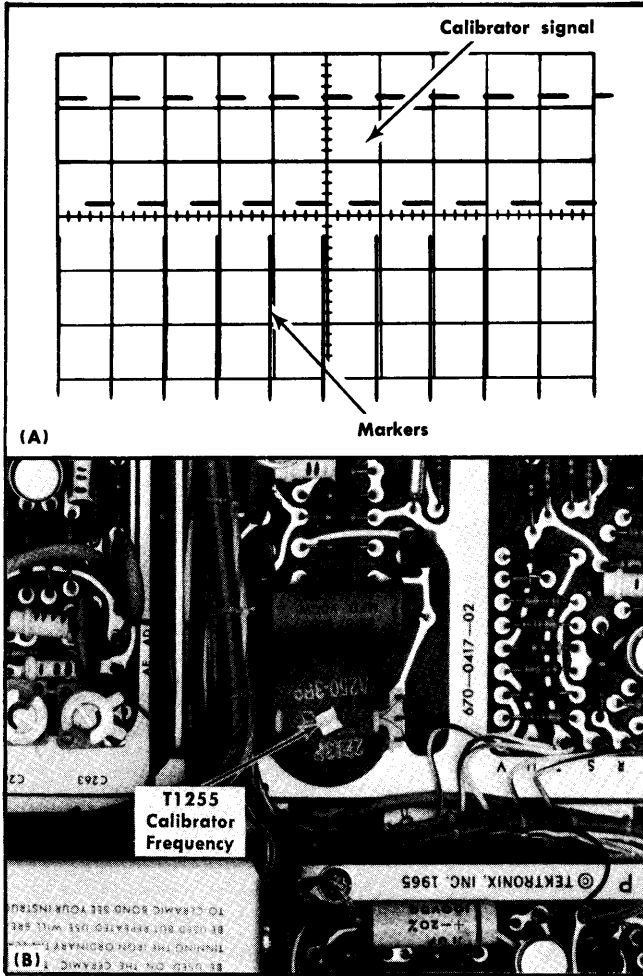

Fig. 5-45. (A) Typical CRT display showing correct calibrator repetition rate, (B) location of Calibrator Frequency adjustment.

68. Check Calibrator Duty Cycle

a. Change the following control settings:

CH 1 VOLTS/DIV	20 mV
MODE	CH 1
A and B TIME/DIV	.1 ms

b. Center the display vertically with the Channel 1 POSITION control.

c. Set the A LEVEL control so the display starts at the 50% point on the rising portion of the waveform (the INTENSITY control may need to be advanced slightly to see the rising portion of the waveform).

d. Set the MAG switch to $\times 10$.

e. Position the 50% point on the falling edge of the Calibrator waveform to the center vertical line.

f. Set the A SLOPE switch to —.

g. CHECK—50% point on rising edge now displayed not more than two divisions from the center vertical point (duty cycle 49% to 51%; see Fig. 5-46).

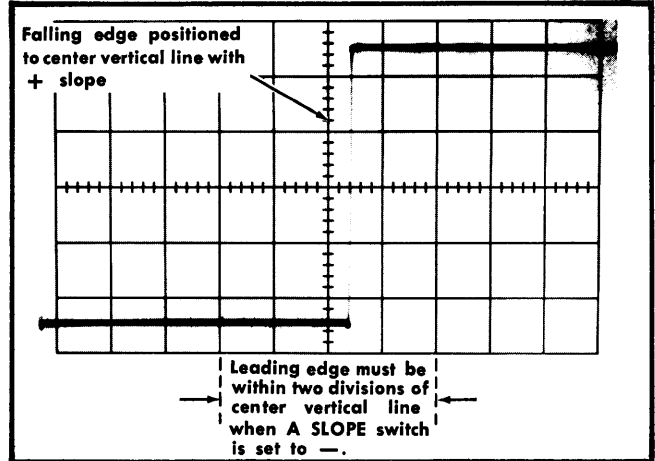

Fig. 5-46. Typical CRT display when checking calibrator duty cycle.

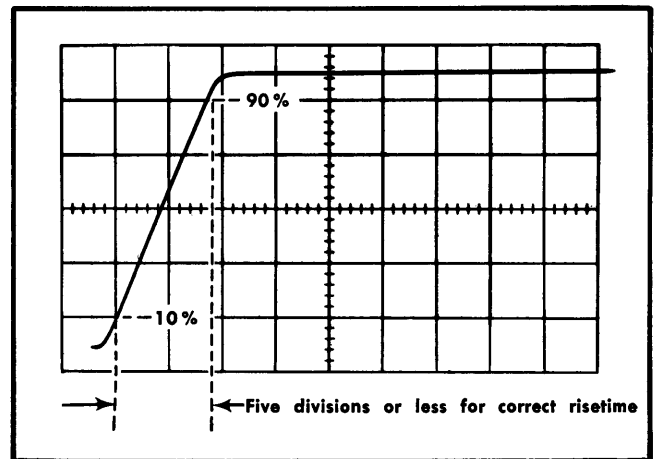

Fig. 5-47. Typical CRT display when checking Calibrator risetime.

69. Check Calibrator Risetime

a. Change the following control settings:

A SLOPE	+
A and B TIME/DIV	.2 μ s
MAG	OFF

b. Set the A LEVEL control so all of the rising portion of the calibrator waveform is visible.

c. Position the 10% point on the leading edge to a vertical graticule line.

d. CHECK—CRT display for five divisions or less between the 10% and 90% points on the leading edge of the calibrator waveform (one microsecond or less risetime; see Fig. 5-47).

e. Disconnect the 18-inch BNC cable.

Performance Check/Calibration—Type 453/R453

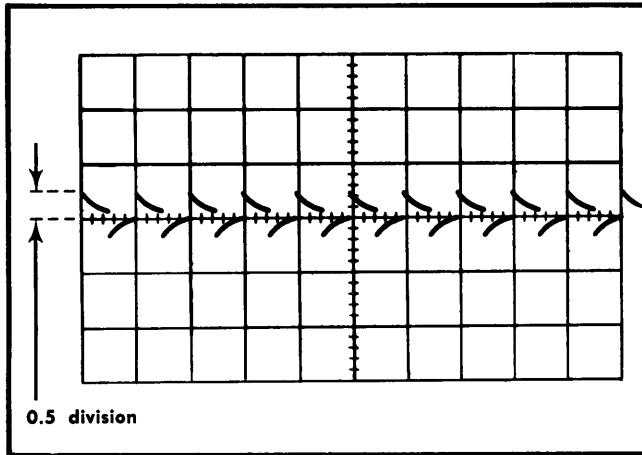

Fig. 5-48. Typical CRT display when checking calibrator current.

70. Check Current through Probe Loop

- Connect the current-measuring probe and passive termination to the Channel 1 INPUT connector.
- Set the passive termination for a sensitivity of 2 mA/mV.
- Clip the current probe around the PROBE LOOP on the side panel.
- Set the CH 1 VOLTS/DIV switch to 5 mV.
- Set the A and B TIME/DIV switch to .5 ms.
- CHECK—CRT display 0.5 division in amplitude (five milliamperes; see Fig. 5-48).

NOTE

This step checks for the presence of current in the PROBE LOOP. This current will remain within the stated 1% accuracy due to the tolerance of the divider resistors and tolerance of the calibrator output voltage (adjusted in step 2). If it is necessary to verify the accuracy of the calibrator current, use a peak current measuring meter with an accuracy of at least 0.25%.

- Disconnect all test equipment.

71. Check/Adjust Z Axis Compensation ①

- Change the following control settings:

TRIGGER	NORM
DELAY-TIME MULTIPLIER	Fully Counterclockwise
A and B TIME/DIV	.1 μ s

- Connect the 10 \times probe to the input connector of the test oscilloscope.
- Connect the 10 \times probe to TP1047 (see Fig. 5-49A).

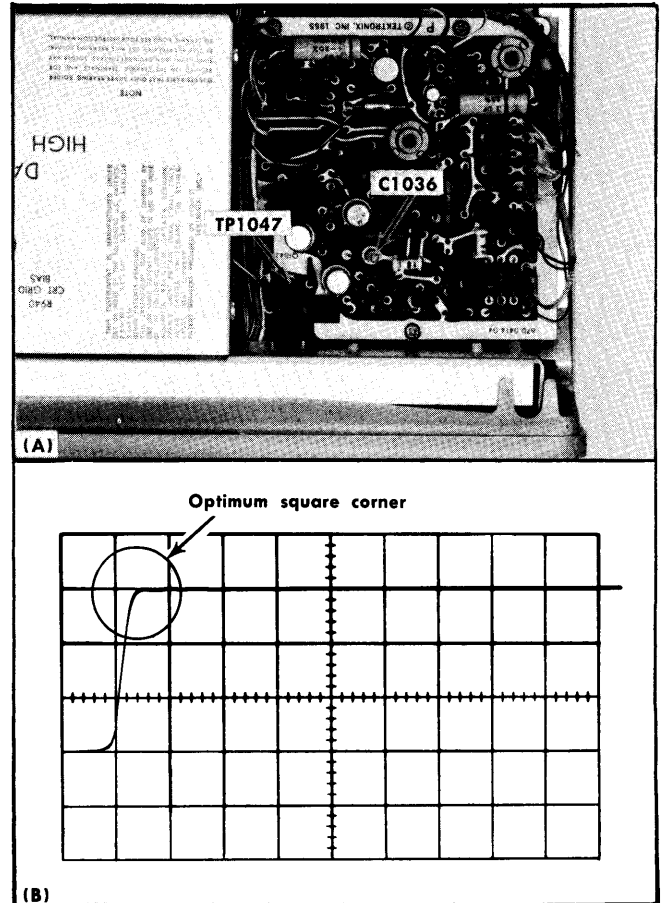

Fig. 5-49. (A) Typical of TP1047 and C1036, (B) typical test oscilloscope display showing correct adjustment of C1036 (vertical deflection, 5 volts/division, sweep rate, 0.1 microsecond/division).

- Set the test oscilloscope for a vertical deflection factor of 0.5 volts/division (5 volts/division total with probe) at a sweep rate of 0.1 microsecond/division.
- Set the INTENSITY control so the test oscilloscope display is three divisions in amplitude.
- CHECK—Test oscilloscope display for optimum square corner (slightly rounded) on blanking gate (see Fig. 5-49B).
- ADJUST—C1036 (see Fig. 5-49A) for optimum square corner on the unblanking gate.
- Disconnect all test equipment.

72. Check External Z Axis Operation

- Set the INTENSITY control to a normal setting.
- Set the A and B TIME/DIV switch to 20 μ s.
- Connect the constant-amplitude generator to the A EXT TRIG INPUT connector through the five-nanosecond GR cable, 50-ohm in-line termination and BNC T connector. Connect the output of the BNC T connector to the Z AXIS INPUT binding posts through a 42-inch BNC cable and the BNC to alligator clips adapter. (Connect black lead of alligator clips adapter to ground post.)

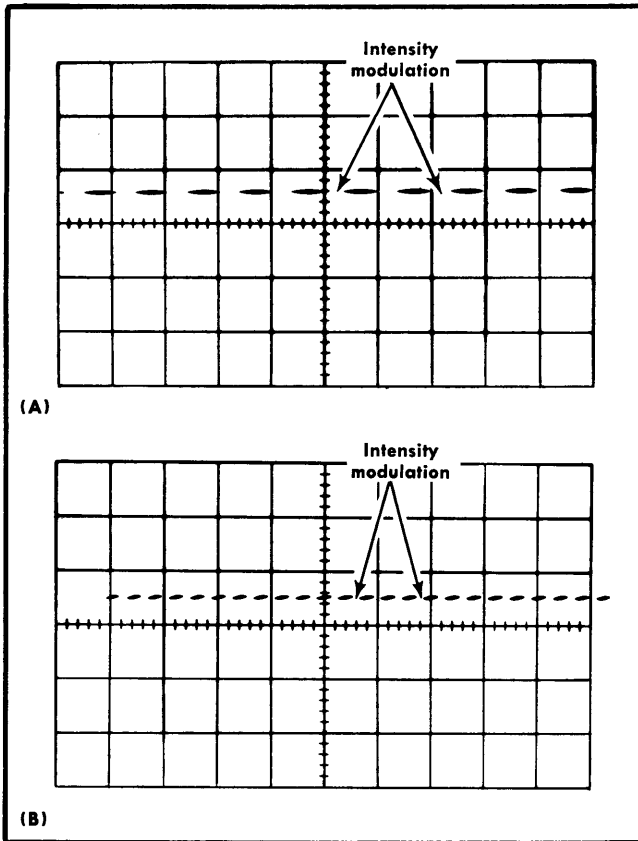

Fig. 5-50. (A) Typical CRT display when checking Z-axis operation at 50 kilohertz, (B) typical CRT display when checking Z-axis operation at 50 megahertz.

- d. Set the A SOURCE to EXT.
- e. Remove the ground strap from between the binding posts.
- f. Set the constant-amplitude generator for five volts output at 50 kilohertz (use calibrated position of generator amplitude control).
- g. CHECK—CRT display for noticeable intensity modulation (see Fig. 5-50A). The INTENSITY control setting may need to be reduced to view trace modulation.
- h. Set the constant-amplitude generator for five volts output at 50 megahertz (use calibrated position of generator amplitude control).
- i. Set the A and B TIME/DIV switch to $.1 \mu\text{s}$.
- j. CHECK—CRT display for noticeable intensity modulation (see Fig. 5-50B). The INTENSITY control setting may need to be reduced to view trace modulation.
- k. Disconnect all test equipment and replace ground strap.

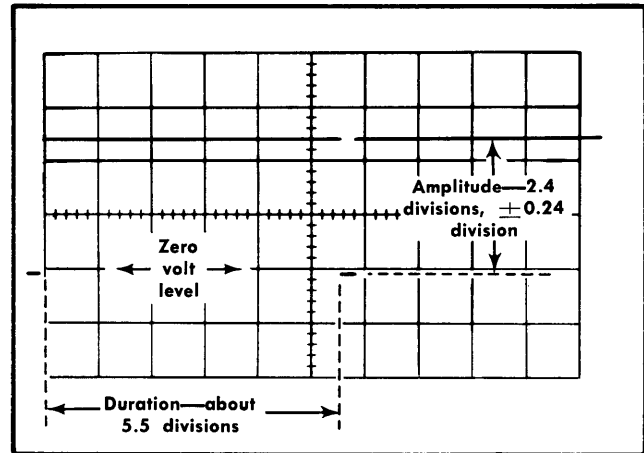

Fig. 5-51. Typical CRT display when checking gate amplitude and duration (vertical deflection, five volts/division; sweep rate, two milliseconds/division).

73. Check A Gate Output Signal

- a. Set the A and B TIME/DIV switch to 1 ms.
- b. Connect the A GATE connector (on side panel) to the test-oscilloscope input connector with the 42-inch BNC cable.
- c. Set the test oscilloscope for a vertical deflection factor of five-volts/division at a sweep rate of two milliseconds/division.
- d. CHECK—Test oscilloscope display for 2.4 divisions, ± 0.24 division, vertical deflection with the bottom of the waveform near the zero-volt level (12 volts, $\pm 10\%$; see Fig. 5-51). Gate duration should be about 5.5 divisions (about 11 times the A TIME/DIV switch setting).

74. Check B Gate Output Signal

- a. Connect the B GATE connector (side panel) to the test-oscilloscope input connector with the 42-inch BNC cable.
- b. Change the following control settings:

A TIME/DIV	2 ms
B TIME/DIV	1 ms
HORIZ DISPLAY	DELAYED SWEEP (B)
- c. CHECK—Test oscilloscope display for 2.4 divisions, ± 0.24 division, vertical deflection with the bottom of the waveform near the zero-volt level (12 volts, $\pm 10\%$; see Fig. 5-51). Gate duration should be about 5.5 divisions (about 11 times the B TIME/DIV switch setting).

This completes the calibration procedure for the Type 453. Disconnect all test equipment and replace the top and bottom covers. If the instrument has been completely checked and calibrated to the tolerances given in this procedure, it will meet the electrical characteristics listed in the Performance Requirement column of the Specifications section of this manual.

SECTION 6

RACKMOUNTING

Introduction

The Tektronix Type R453 Oscilloscope is designed to mount in a standard 19-inch rack. When mounted in accordance with the following mounting procedure this instrument will meet all electrical and environmental characteristics given in Section 1 of this manual.

Rack Dimensions

Height. At least seven inches of vertical space is required to mount this instrument in a rack.

Width. Minimum width of the opening between the left and right front rails of the rack must be $17\frac{5}{8}$ inches. This allows room on each side of the instrument for the slide-out tracks to operate freely, permitting the instrument to move smoothly in and out of the rack.

Depth. Total depth necessary to mount the Type R453 in a cabinet rack is 18 inches. This allows room for air circulation, power cord connections and the necessary mounting hardware.

Slide-out Tracks

Fig. 6-1 shows the Type R453 installed in a cabinet-type rack. The slide-out tracks provided with the Type R453 permit it to be extended out of the rack for maintenance or calibration without removing the instrument from the rack. In the fully extended position, the Type R453 can be tilted up so the bottom of the instrument can be reached for maintenance or calibration. To operate the Type R453 in the extended position, be sure the power cord and any interconnecting cables are long enough for this purpose. When not extended, the instrument is held in the rack with four securing screws (see Fig. 6-1A).

The slide-out tracks consist of two assemblies—one for the left side of the instrument and one for the right side. Fig. 6-2 shows the complete slide-out track assemblies. The stationary section of each assembly attaches to the front and rear rails of the rack, and the chassis section is attached to the instrument. The intermediate section slides between the stationary and chassis sections and allows the Type R453 to be extended out of the rack. When the instrument is shipped, the stationary and intermediate sections of the tracks are packaged as matched sets and should not be separated. To identify the left or right assembly, note the position of the automatic latch (see Fig. 6-2). When mounted in the rack, the automatic latch should be at the top of both assemblies. The chassis sections are installed on the instrument at the factory.

The hardware needed to mount the slide-out tracks is shown in Fig. 6-3. Since the hardware supplied is intended to make the tracks compatible with a variety of cabinet racks and installation methods, not all of it will be needed for this

installation. Use only the hardware that is required for the mounting method used.

Mounting Procedure

The following mounting procedure uses the rear support kit (see Fig. 6-4 and 6-7) to meet the environmental characteristics of the instrument (shock and vibration). Two alternative mounting methods are described at the end of this procedure. However, when mounted according to these alternative methods, the instrument may not meet the given environmental characteristics for shock and vibration.

The mounting flanges of the stationary sections may be mounted in front of or behind the front rails of the rack, depending on the type of rack. If the front rails of the rack are tapped for 10-32 screws, the mounting flanges are placed in front of the rails. If the front rails of the rack are not tapped for 10-32 screws, the mounting flanges are placed behind the front rail and a bar nut is used. Fig. 6-5 shows these methods of mounting the stationary sections.

The rear of the stationary sections must be firmly supported to provide a shock-mounted installation. This rear support must be located 17.471 inches, ± 0.031 inches, from the outside surface of the front rail when the mounting flange is mounted outside of the rail, or 17.531 inches, ± 0.031 inches, from the rear surface of the front rail when the mounting flange is mounted behind the front rail. If the cabinet rack does not have a strong supporting member located the correct distance from the front rail, an additional support must be added. The instrument will not meet the environmental specifications unless firmly supported at this point. Fig. 6-4 illustrates a typical rear installation using the rear support kit and gives the necessary dimensions.

Use the following procedure to install the Type R453 in a rack:

1. Select the proper front-rail mounting holes for the stationary section using the measurements shown in Fig. 6-6.

2a. If the mounting flanges of the stationary sections are to be mounted in front of the front rails (rails tapped for 10-32 screws), mount each stationary section as shown in Fig. 6-5A.

2b. If the mounting flanges of the stationary sections are to be mounted behind the front rails (rails not tapped for 10-32 screws), mount each stationary section as shown in Fig. 6-5B.

3. Attach an angle bracket to both rear rails of the rack through the spacer block, stationary section and into the rear rail of the rack. Note that the holes in the spacer block are not centered. Be sure to mount the block with the narrow edge toward the front of the rack; otherwise, the instrument may not slide all the way into the rack. Do not tighten the mounting screws. Fig. 6-7 shows the parts in the rear support kit and the order in which they are assembled.

Rackmounting—Type R453

4. Assemble the support pin to the angle bracket in the order shown in Fig. 6-7. Leave the spacer (washer) off, but install the neoprene washer.

5. Install a support block on each side of the instrument as shown in Fig. 6-8.

6. Refer to Fig. 6-9 to insert the instrument in the rack. Do not connect the power cord or install the securing screws until all adjustments have been made.

7. With the instruments pushed all the way into the rack, adjust the angle brackets so the neoprene washers on the support pins are seated firmly against the rear of the instrument and the support pins are correctly positioned in the support block on the rear of the instrument. Tighten all screws.

8. Pull the instrument partially out of the rack.

9. Remove the neoprene washers from the support pins and place the spacers on the pins. Replace the neoprene washers.

10. Position the instrument so the pivot screws (widest part of instrument) are approximately even with the front rails.

11. Adjust the alignment of the stationary sections according to the procedure outlined in Fig. 6-10. (If the rear alignment is changed, recheck the rear support pins for correct alignment.)

12. After the tracks operate smoothly, connect the power cord to the power source.

13. Push the instrument all the way into the rack and secure it to the rack with the securing screws and washers as shown in Fig. 6-9C.

NOTE

The securing screws are an important part of the shock-mounted installation. If the front rails are not tapped for the 10-32 securing screws, other means must be provided for securing the instrument to the rack.

Alternative Rear Mounting Methods

CAUTION

Although the following methods provide satisfactory mounting under normal conditions, they do not provide solid support at the rear of the instrument. If the instrument is subjected to severe shock or vibration when mounted using the following methods, it may be damaged.

An alternative method of supporting the rear of the instrument is shown in Fig. 6-11. The rear support brackets supplied with the instrument allow it to be mounted in a rack which has a spacing between the front and rear rails of 11 to 24 inches. Fig. 6-11A illustrates the mounting method if the rear rails are tapped for 10-32 screws, and Fig. 6-11B illustrates the mounting method if the rear rails are not tapped for 10-32 screws. The rear support kit is not used for this installation.

If the rack does not have a rear rail, or if the distance between the front and rear rails is too large, the instrument may be mounted without the use of the slide-out tracks. Fasten the instrument to the front rails of the rack with the securing screws and washers. This mounting method should be used only if the instrument will not be subjected to shock or vibration and if it is installed in a stationary location.

Removing or Installing the Instrument

After initial installation and adjustment of the slide-out tracks, the Type R453 can be removed or installed by following the instructions given in Fig. 6-9. No further adjustments are required under normal conditions.

Slide-out Track Lubrication

The slide-out tracks normally require no lubrication. The special finish on the sliding surfaces provides permanent lubrication. However, if the tracks do not slide smoothly even after proper adjustment, a thin coating of paraffin rubbed onto the sliding surfaces may improve operation.

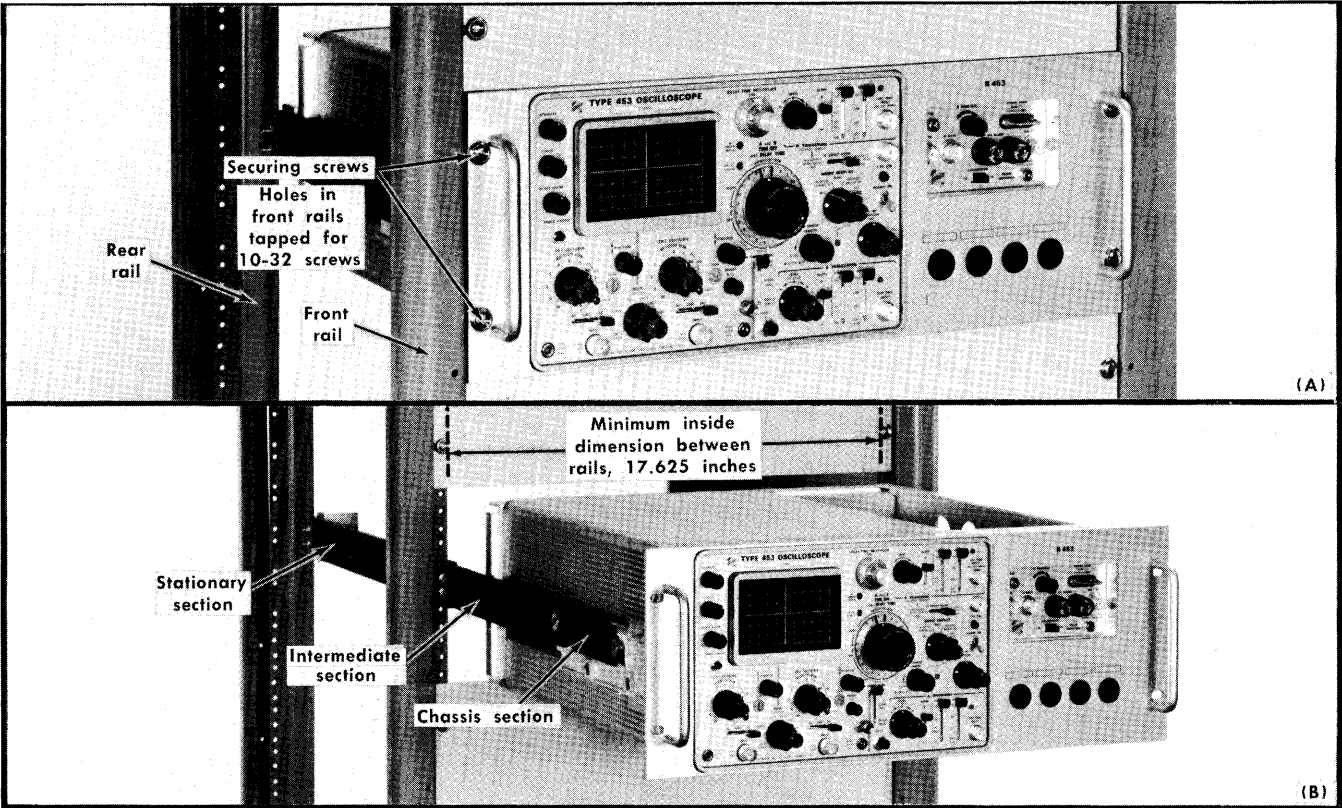

Fig. 6-1. The Type R453 installed in a cabinet rack (sides removed): (A) Held into rack with securing screws; (B) extended on slideout tracks.

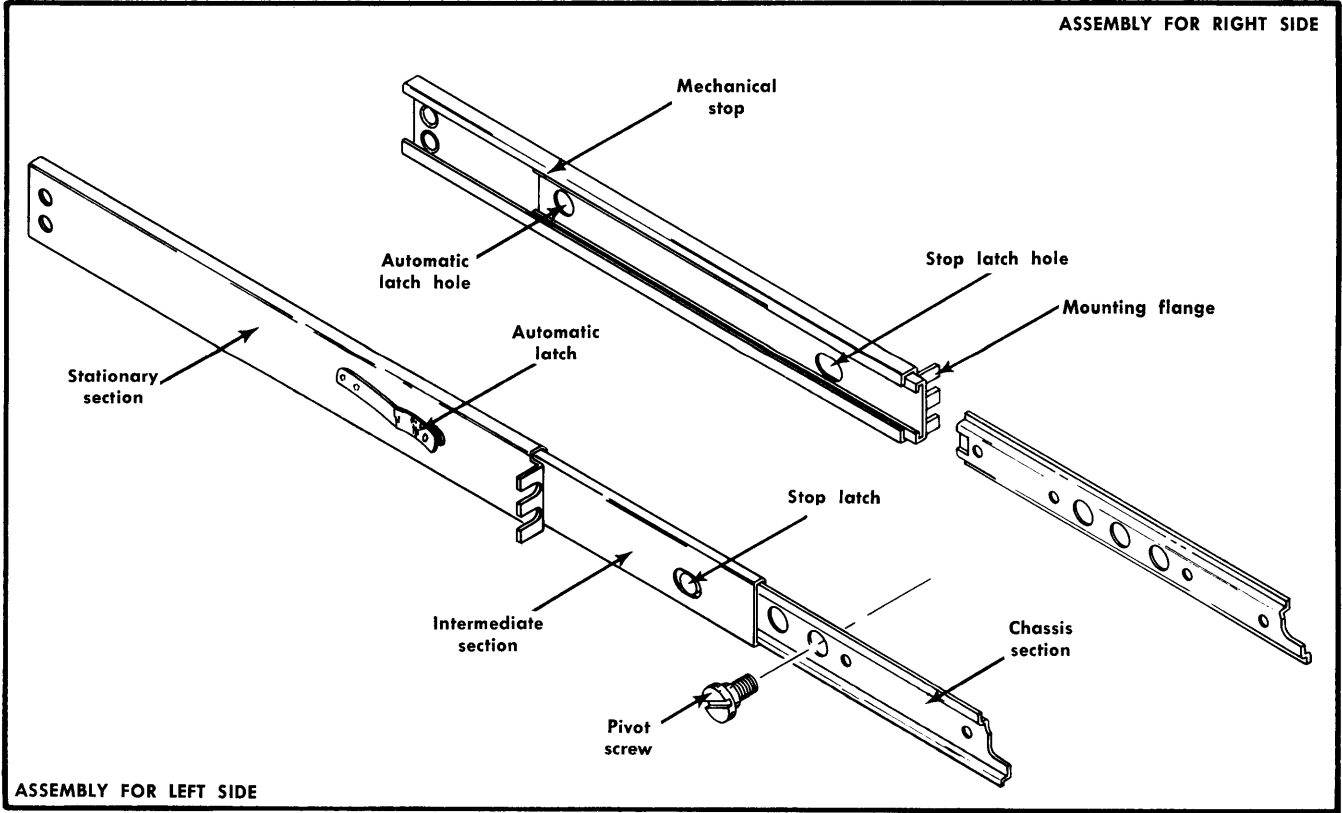

Fig. 6-2. Slideout track assemblies.

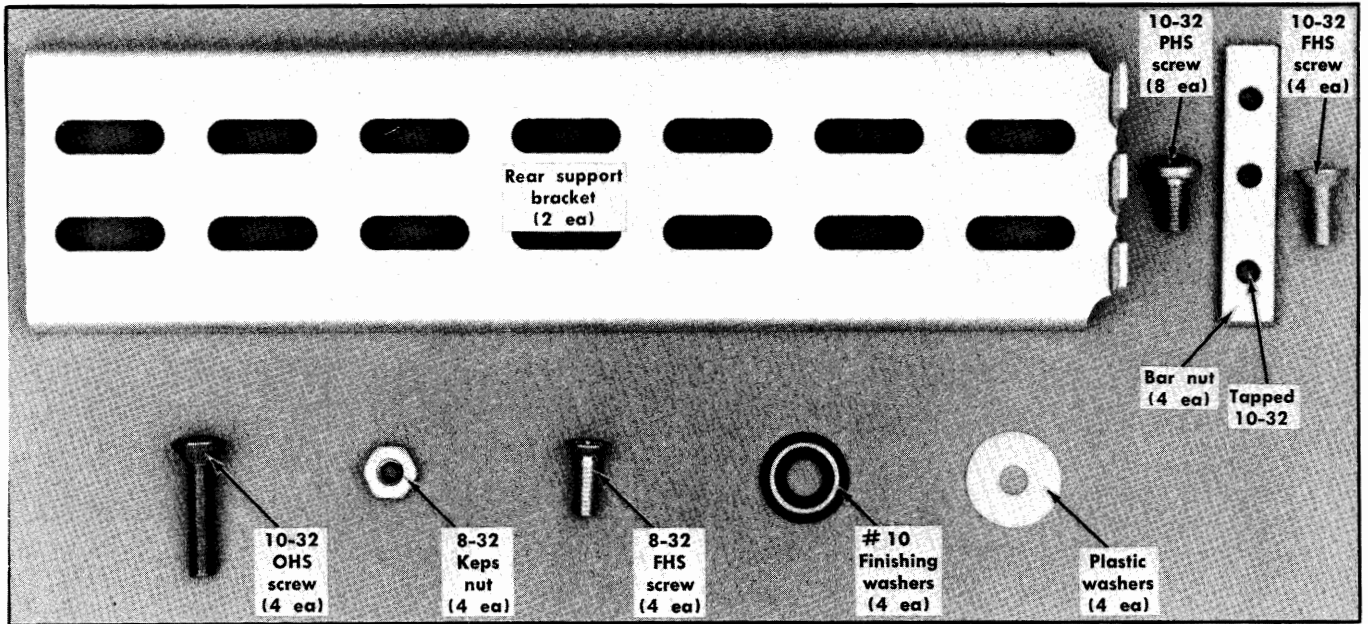

Fig. 6-3. Hardware needed to mount the instrument in the cabinet rack.

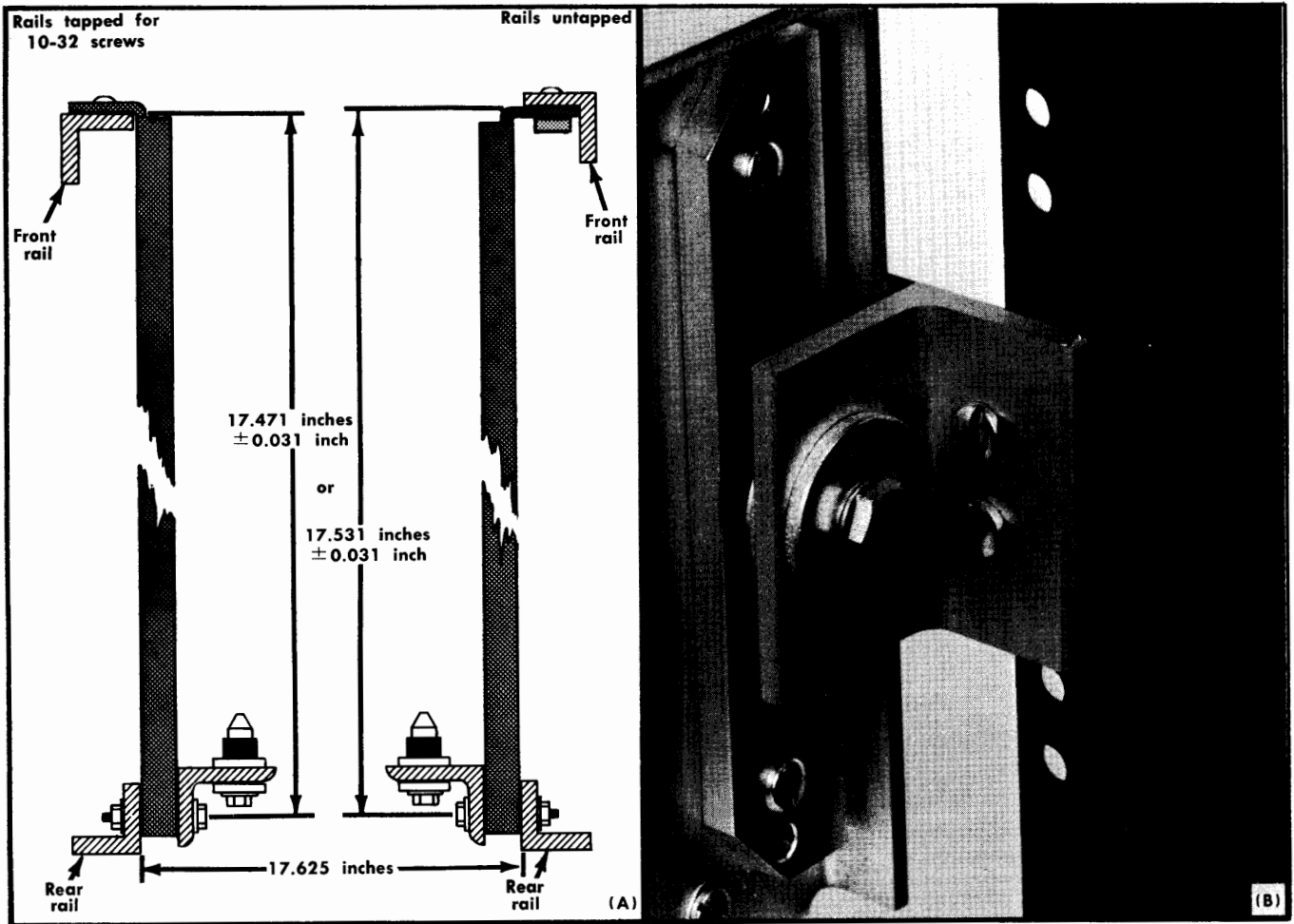

Fig. 6-4. Supporting the rear of the stationary sections: (A) Dimensions necessary; (B) Completed installation.

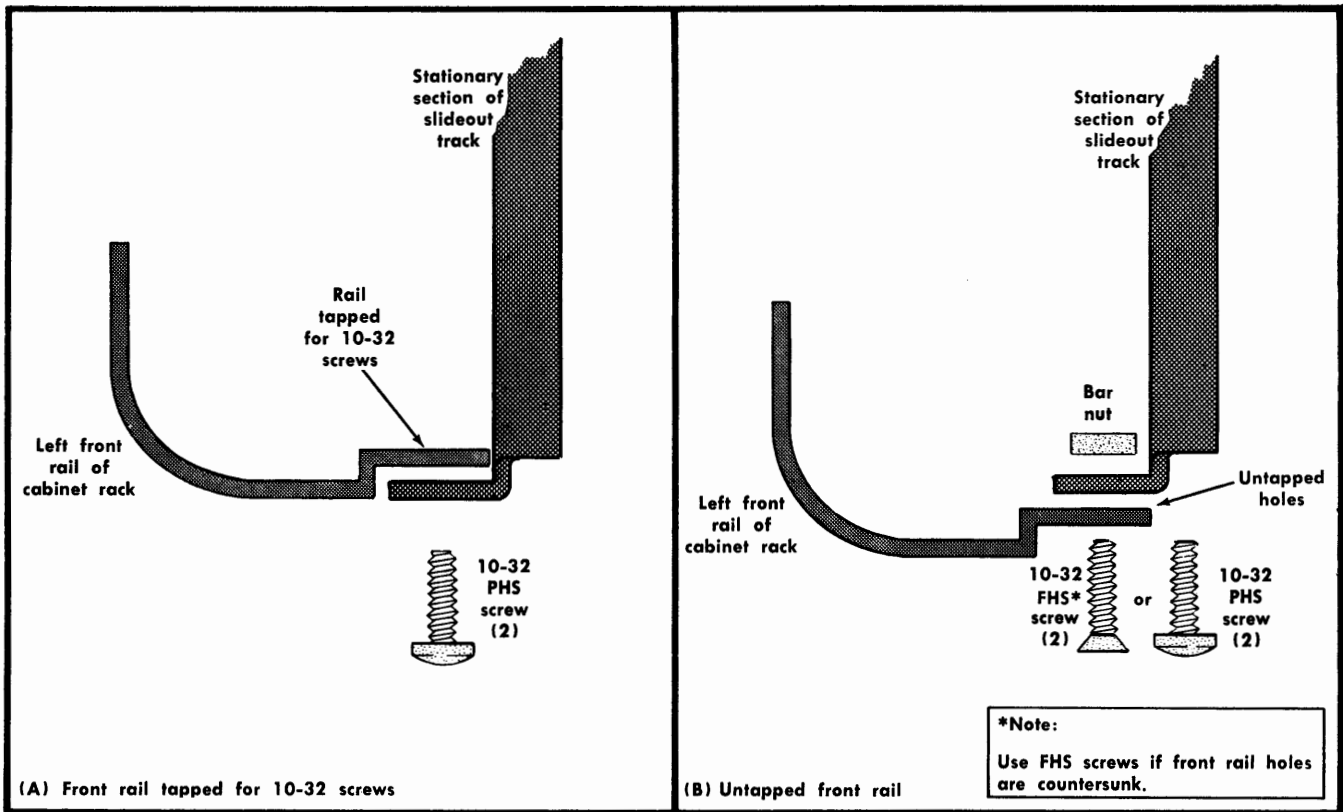

Fig. 6-5. Methods of mounting the stationary section to the front rails.

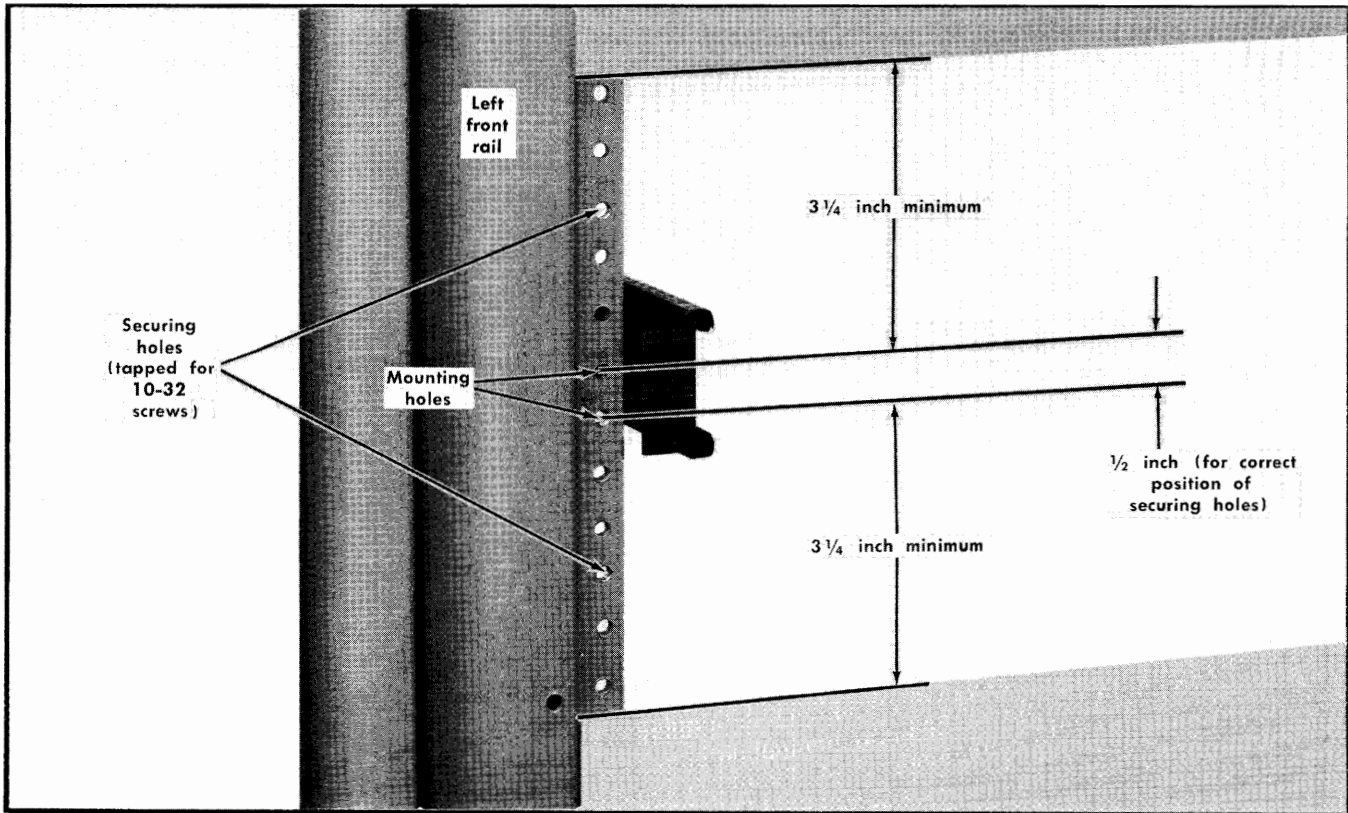

Fig. 6-6. Locating the mounting holes for the left stationary section. Same dimensions apply to right stationary section.

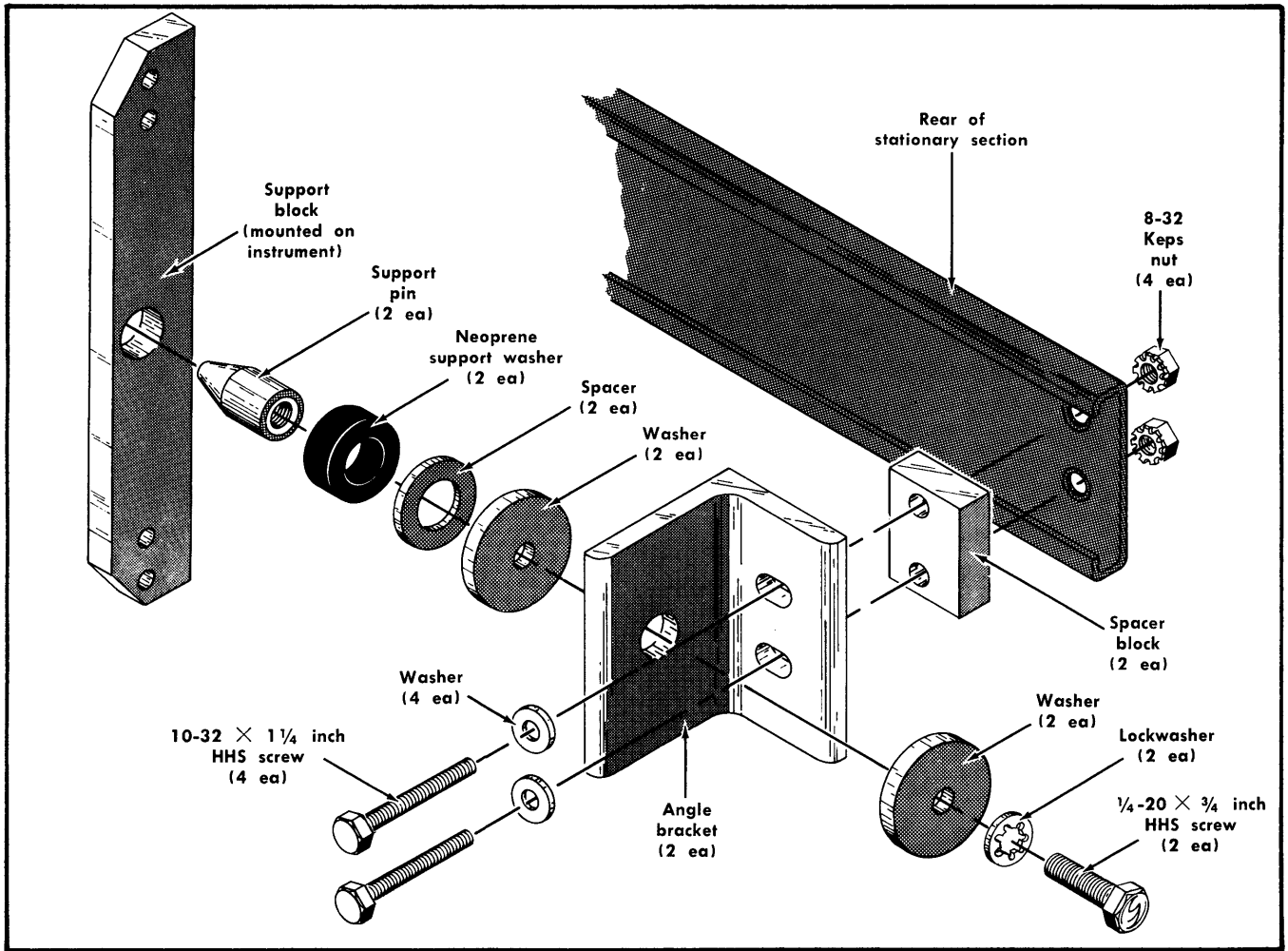

Fig. 6-7. Rear Support kit.

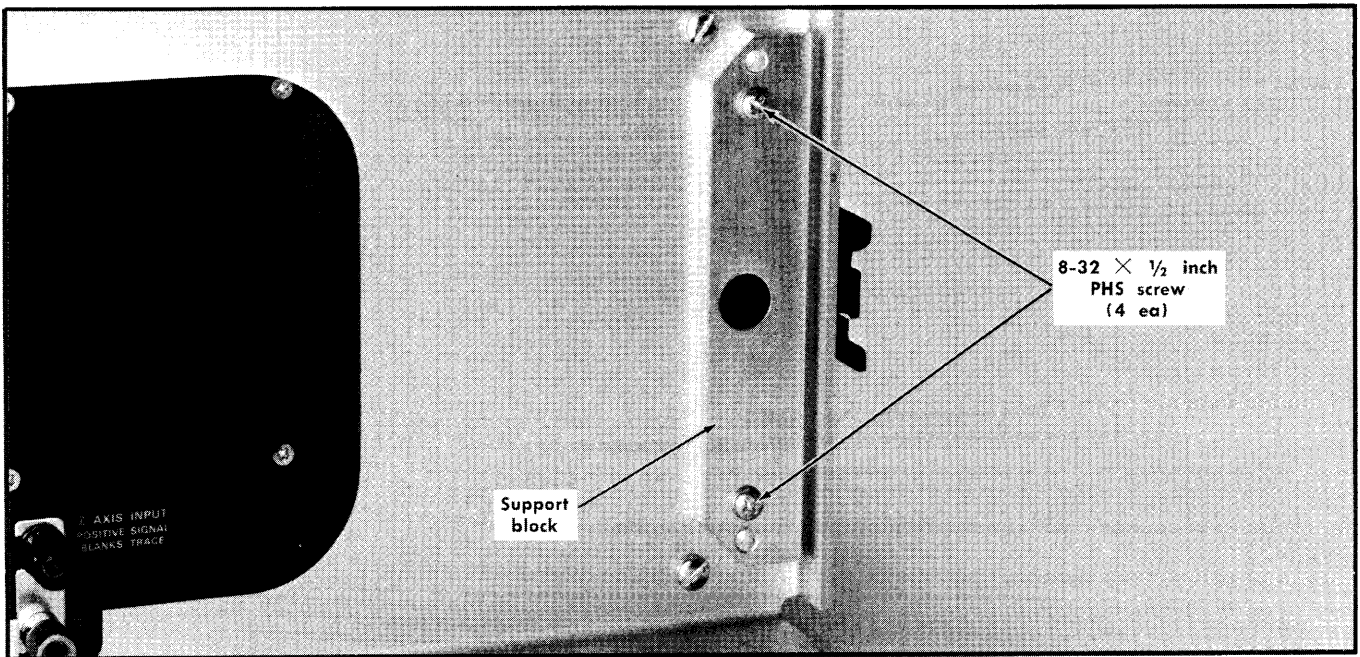

Fig. 6-8. Installing the support block on the instrument.

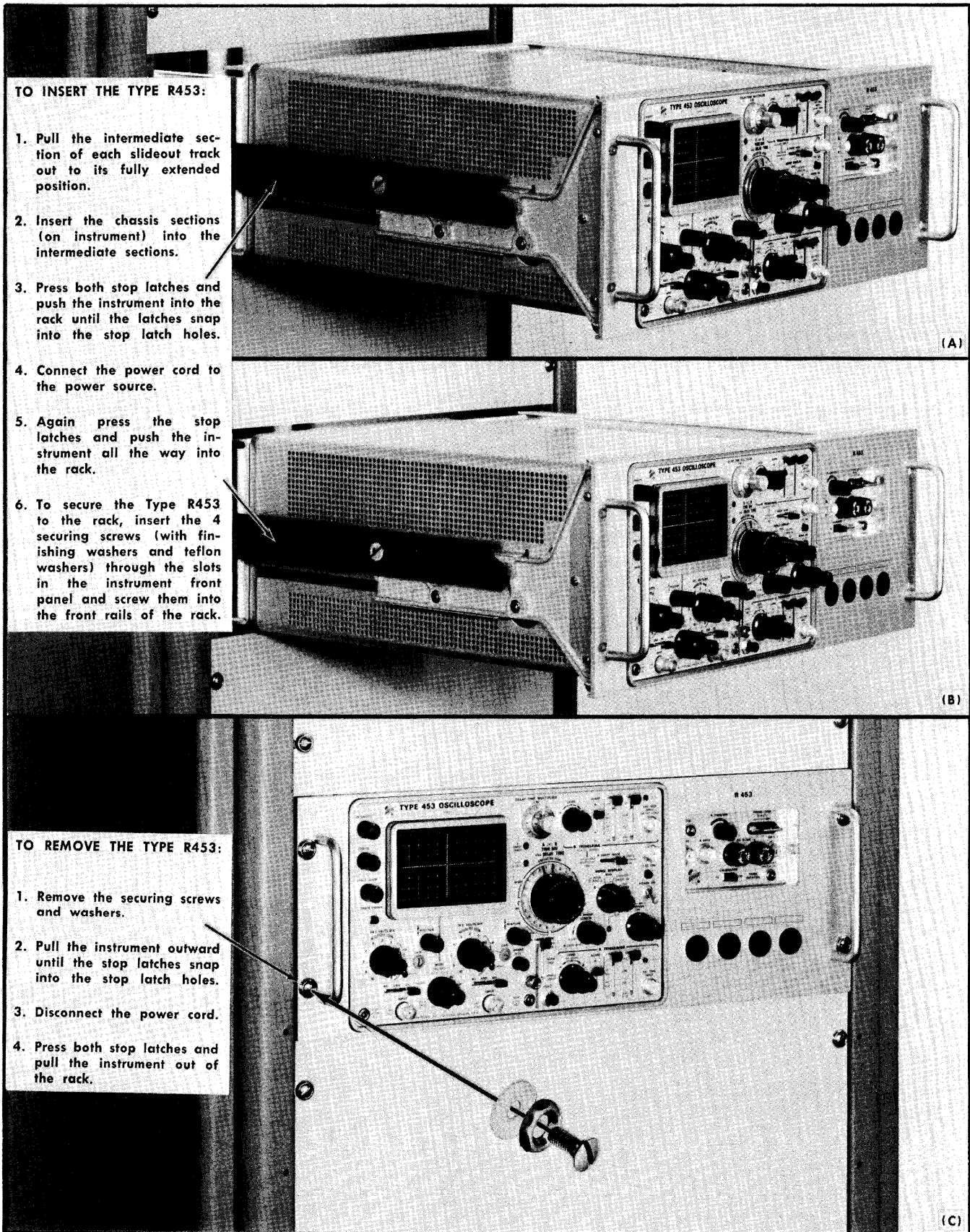

Fig. 6-9. Procedure for inserting or removing the instrument after the slideout tracks have been installed.

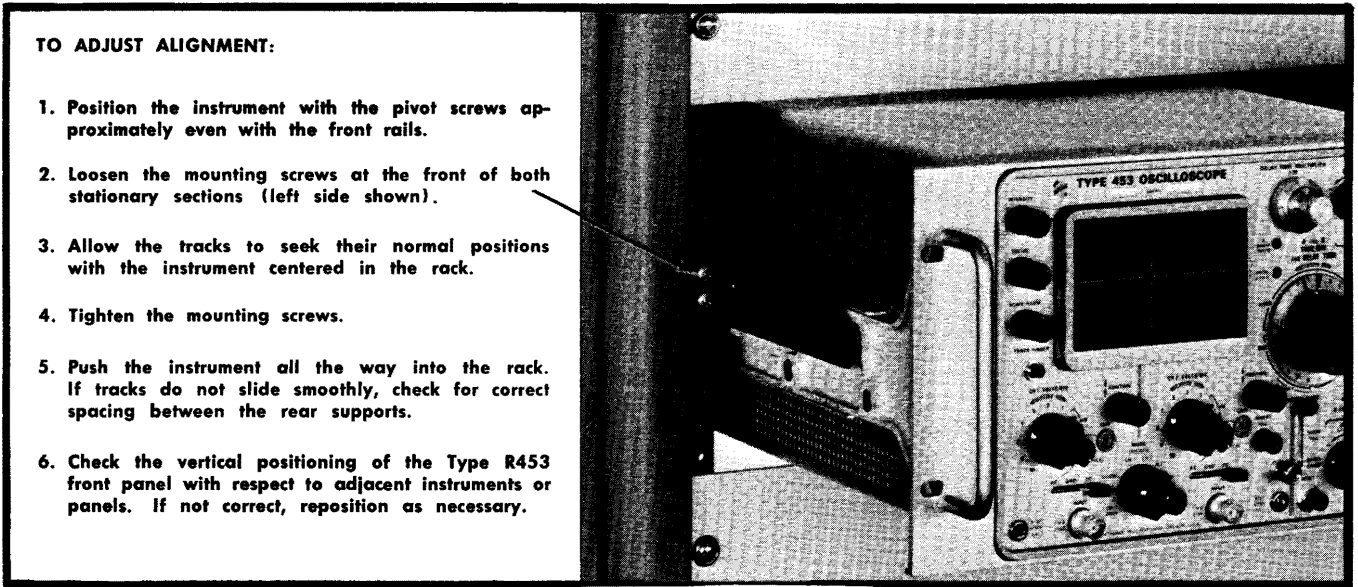

Fig. 6-10. Alignment adjustments for correct operation.

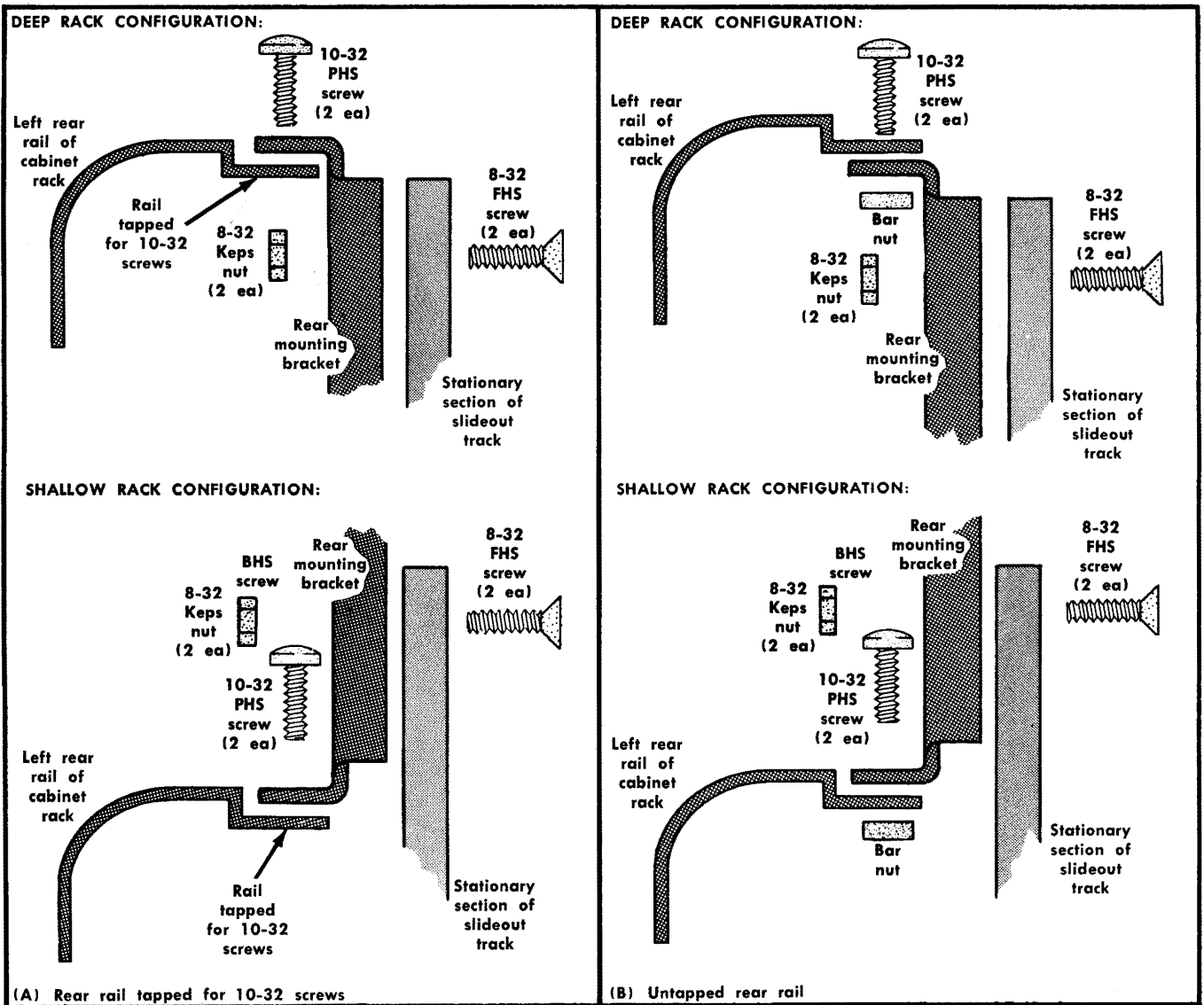
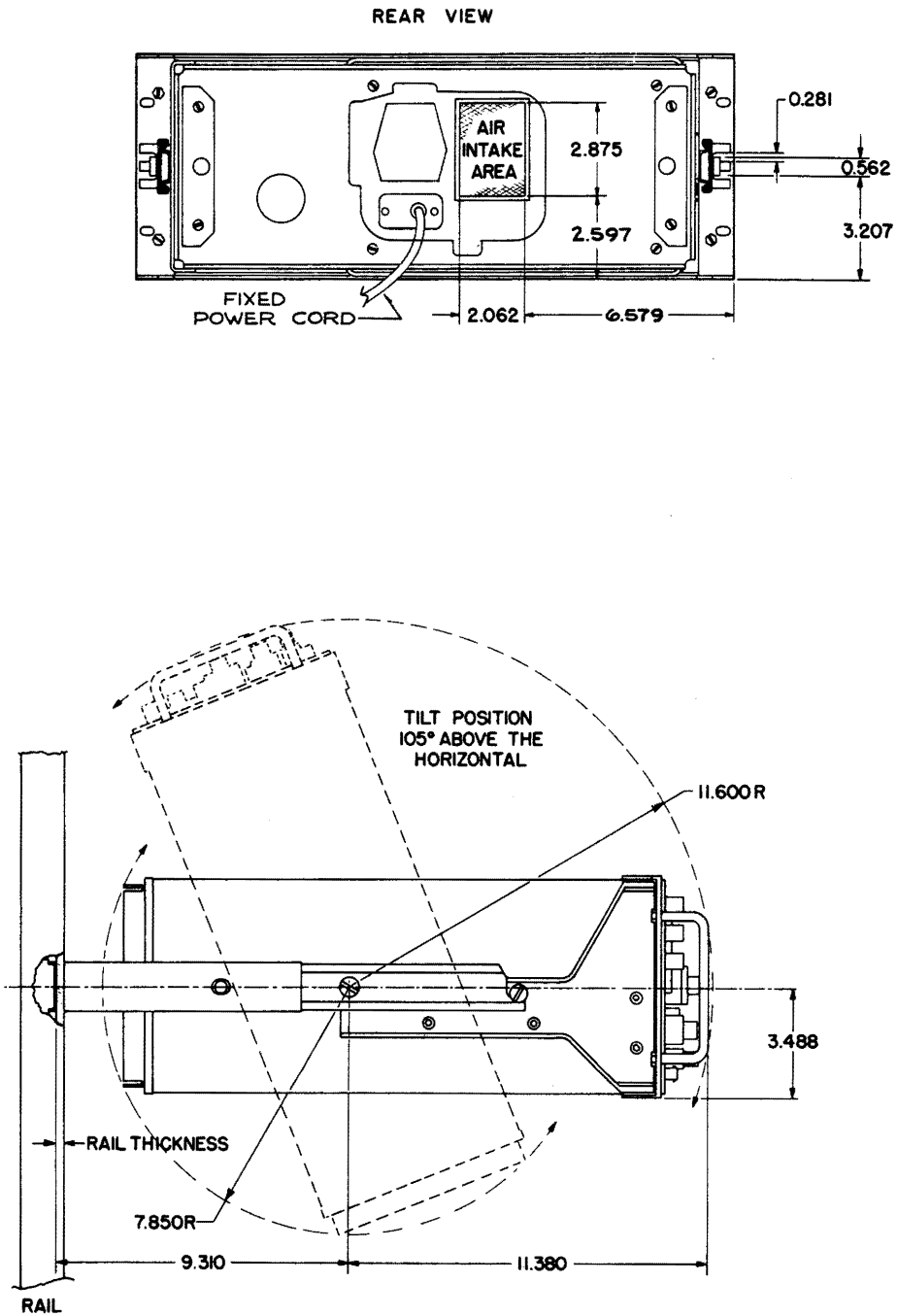
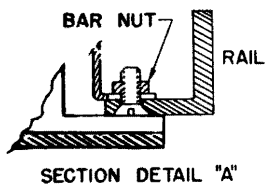
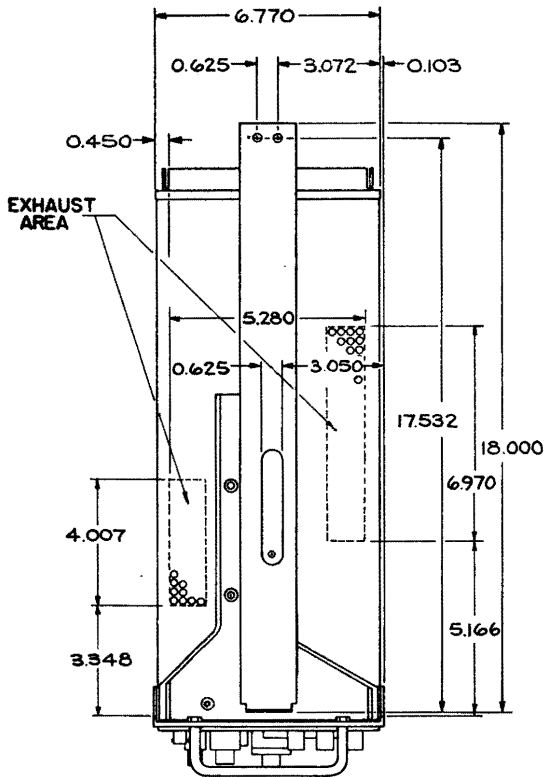
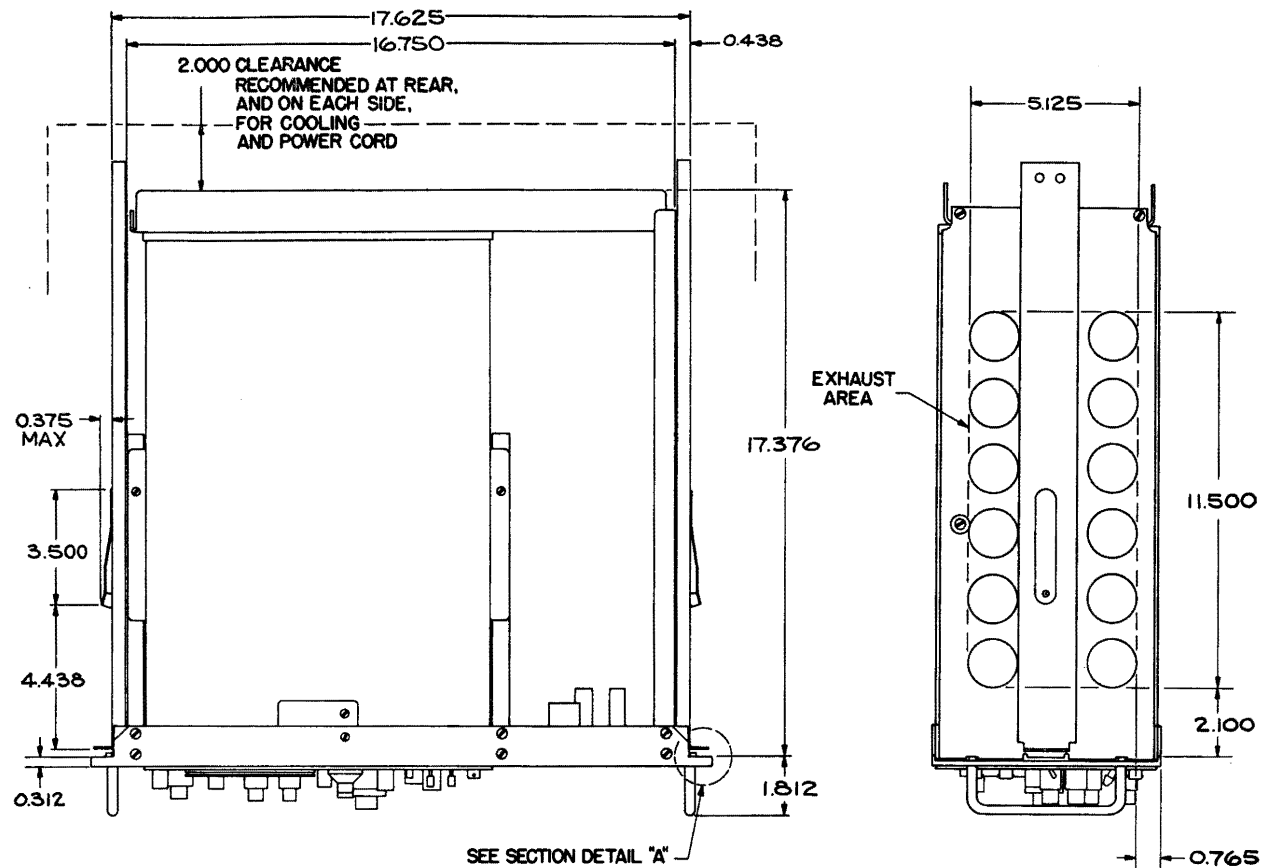

Fig. 6-11. Alternative method of installing the instrument using rear support brackets.



NOTES:
 1. ALL DIMENSIONS ARE REFERENCE
 DIMENSIONS EXCEPT AS NOTED

Fig. 6-12A. Dimensional drawing.



RECOMMENDED MOUNTING

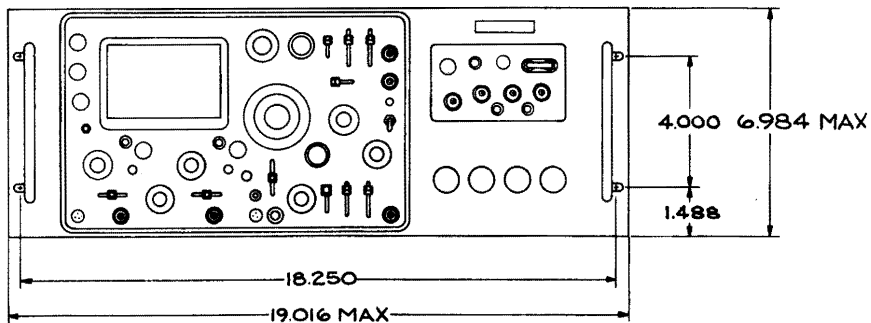

Fig. 6-128. Dimensional drawing.

INDEX OF ELECTRICAL PARTS LIST

Title	Page No.
CHASSIS	7-1
Z AXIS Circuit Board Assembly	7-12
LOW VOLTAGE REGULATOR Circuit Board Assembly	7-14
VERT OUTPUT AMP Circuit Board Assembly	7-16
A SWEEP Circuit Board Assembly	7-18
B SWEEP Circuit Board Assembly	7-24
VERTICAL PREAMP Circuit Board Assembly	7-29

SECTION 7

ELECTRICAL PARTS LIST

Values are fixed unless marked Variable.

Ckt. No.	Tektronix Part No.	Serial/Model No. Eff	No. Disc	Description
CHASSIS				
Bulbs				
B75	150-0030-00			Neon, NE-2 V
B175	150-0030-00			Neon, NE-2 V
B400	150-0035-00			Neon, A1D
B401	150-0035-00			Neon, A1D
B530W	150-0035-00			Neon, A1D
B596	150-0046-00			Incandescent #21070
B597 ¹	260-0717-00			
B849	150-0035-00			Neon, A1D
B973	150-0030-00			Neon, NE-2 V
B974	150-0030-00			Neon, NE-2 V
B975	150-0030-00			Neon, NE-2 V
B1107	150-0045-00			Incandescent #685
B1108	150-0047-00			Incandescent #CN8-398
B1109	150-0047-00			Incandescent #CN8-398
Capacitors				
Tolerance $\pm 20\%$ unless otherwise indicated.				
C1	*285-0697-00			0.1 μ F MT 600 V
C3	281-0617-00			15 pF Cer 200 V
C6B	281-0064-00			0.25-1.5 pF, Var Tub.
C6C	281-0102-00			1.7-11 pF, Var Air
C7B	281-0064-00			0.25-1.5 pF, Var Tub.
C7C	281-0100-00			1.4-7.3 pF, Var Air
C7E	281-0505-00			12 pF Cer 500 V
C8B	281-0099-00			1.3-5.4 pF, Var Air
C8C } C8E }	281-0083-00			0.25-1.5 pF, Var Tub. 50 pF Mica 10%
C8D	281-0544-00			5.6 pF (nominal value) Selected
C9B	281-0100-00			1.4-7.3 pF, Var Air
C9C } C9E }	281-0086-00			0.25-1.5 pF, Var Tub. 500 pF Mica 10%
C9D	281-0593-00			3.9 pF (nominal value) Selected

¹Furnished as a unit with 5569.

CHASSIS (cont)

Ckt. No.	Tektronix Part No.	Serial/Model No. Eff	Disc	Description			
Capacitors (cont)							
C9F	281-0547-00			2.7 pF	Cer	500 V 10%	
C10	281-0529-00			1.5 pF	Cer	500 V ±0.25 pF	
C11	281-0099-00			1.3-5.4 pF, Var	Air		
C13	281-0617-00			15 pF	Cer	200 V	
C43E	281-0578-00	20000	38689X	18 pF	Cer	500 V 5%	
C44B	281-0592-00	20000	38689X	4.7 pF	Cer	±0.5 pF	
C73	281-0534-00			3.3 pF	Cer	±0.25 pF	
C100	283-0092-00			0.03 μF	Cer	200 V +80%—20%	
C101	*285-0697-00			0.1 μF	MT	600 V	
C103	281-0617-00			15 pF	Cer	200 V	
C106B	281-0064-00			0.25-1.5 pF, Var	Tub.		
C106C	281-0102-00			1.7-11 pF, Var	Air		
C107B	281-0064-00			0.25-1.5 pF, Var	Tub.		
C107C	281-0100-00			1.4-7.3 pF, Var	Air		
C107E	281-0505-00			12 pF	Cer	500 V 10%	
C108B	281-0099-00			1.3-5.4 pF, Var	Air		
C108C	281-0083-00			0.25-1.5 pF, Var	Tub.		
C108E		50 pF	Mica		10%		
C108D		281-0544-00			5.6 pF (nominal value)	Selected	
C109B		281-0100-00			1.4-7.3 pF, Var	Air	
C109C	281-0086-00			0.25-1.5 pF, Var	Tub.		
C109E		500 pF	Mica		10%		
C109D		281-0593-00			3.9 pF (nominal value)	Selected	
C109F		281-0547-00			2.7 pF	Cer	500 V 10%
C110	281-0529-00			1.5 pF	Cer	500 V ±0.25 pF	
C111	281-0099-00			1.3-5.4 pF, Var	Air		
C113	281-0617-00			15 pF	Cer	200 V	
C143E	281-0578-00	20000	38689X	18 pF	Cer	500 V 5%	
C144B	281-0592-00	20000	38689X	4.7 pF	Cer	±0.5 pF	
C173	281-0534-00			3.3 pF	Cer	±0.25 pF	
C295	283-0080-00			0.022 μF	Cer	25 V +80%—20%	
C296	283-0080-00			0.022 μF	Cer	25 V +80%—20%	
C365	283-0092-00			0.03 μF	Cer	200 V +80%—20%	
C432	281-0510-00			22 pF	Cer	500 V	
C433A	281-0505-00			12 pF	Cer	500 V 10%	
C433B	281-0557-00			1.8 pF	Cer	500 V	
C435	283-0013-00			0.01 μF	Cer	1000 V	
C436	281-0523-00			100 pF	Cer	350 V	
C530A	281-0010-00			4.5-25 pF, Var	Cer		
C530B	283-0097-00			84 pF	Cer	1000 V 2%	
C530C	*295-0089-00			0.001 μF		Timing capacitor assembly	
C530D		0.01 μF					
C530E		0.1 μF					
C530F		1 μF					
C530G		10 μF					

CHASSIS (cont)

Ckt. No.	Tektronix Part No.	Serial/Model No. Eff	Disc	Description			
Capacitors (cont)							
C530H	281-0523-00			100 pF	Cer	350 V	
C530J	281-0523-00			100 pF	Cer	350 V	
C530K	283-0032-00			470 pF	Cer	500 V	5%
C550C	281-0551-00			390 pF	Cer	500 V	10%
C550D	285-0699-00			0.0047 μ F	PTM	100 V	10%
C550E	290-0282-00			0.047 μ F	Elect.	35 V	10%
C550F	290-0283-00			0.47 μ F	Elect.	35 V	10%
C550G	290-0284-00			4.7 μ F	Elect.	35 V	10%
C559	283-0081-00			0.1 μ F	Cer	25 V	+80%—20%
C569	283-0078-00	20000	43959	0.001 μ F	Cer	500 V	
C569	283-0092-00	43960		0.03 μ F	Cer	200 V	+80%—20%
C602	281-0510-00			22 pF	Cer	500 V	
C613A	281-0505-00			12 pF	Cer	500 V	10%
C613B	281-0557-00			1.8 pF	Cer	500 V	
C615	283-0013-00			0.01 μ F	Cer	1000 V	
C616	281-0523-00			100 pF	Cer	350 V	
C740A	281-0010-00			4.5-25 pF, Var	Cer		
C740B	283-0097-00			84 pF	Cer	1000 V	2%
C740C	*295-0079-00			0.001 μ F	Timing capacitor assembly		
C740D		0.01 μ F					
C740E		0.1 μ F					
C740F		1 μ F					
C740H		281-0523-00					100 pF
C808	290-0267-00			1 μ F	Elect.	35 V	
C886	285-0572-00			0.1 μ F	PTM	200 V	
C906	283-0044-00			0.001 μ F	Cer	3000 V	
C911	290-0159-00			2 μ F	Elect.	150 V	
C937	290-0312-00			47 μ F	Elect.	35 V	10%
C940	283-0120-00			0.015 μ F	Cer	2500 V	80%—20%
C945	283-0120-00			0.015 μ F	Cer	2500 V	80%—20%
C946	283-0120-00			0.015 μ F	Cer	2500 V	80%—20%
C952	283-0120-00			0.015 μ F	Cer	2500 V	80%—20%
C953	281-0556-00			400 pF	Cer	10,000 V	
C954	283-0021-00			0.001 μ F	Cer	5000 V	
C961	281-0556-00			500 pF	Cer	10,000 V	
C966	283-0120-00			0.015 μ F	Cer	2500 V	+80%—30%
C972	283-0079-00			0.01 μ F	Cer	250 V	
C976	283-0044-00			0.001 μ F	Cer	3000 V	
C979	283-0060-00			100 pF	Cer	200 V	5%
C985	285-0572-00			0.1 μ F	PTM	200 V	
C1102	285-0696-00	20000	30719X	0.5 μ F	PTM	600 V	10%
C1105	283-0080-00			0.022 μ F	Cer	25 V	+80%—20%

CHASSIS (cont)

Ckt. No.	Tektronix Part No.	Serial/Model No. Eff	Disc	Description		
Capacitors (cont)						
C1111	285-0566-00			0.022 μ F	PTM	200 V
C1112	290-0281-00			1500 μ F	Elect.	25 V
C1141	285-0566-00			0.022 μ F	PTM	200 V
C1142	290-0281-00			1500 μ F	Elect.	25 V
C1171	285-0566-00			0.022 μ F	PTM	200 V
C1172	290-0280-00			200 μ F	Elect.	150 V
C1191	283-0006-00			0.02 μ F	Cer	500 V
C1200	285-0696-00	X30720		0.5 μ F	PTM	600 V
C1201	285-0566-00			0.022 μ F	PTM	200 V
C1202	290-0280-00			200 μ F	Elect.	150 V
C1204	290-0214-00			10 μ F	Elect.	250 V
C1211	285-0566-00			0.022 μ F	PTM	200 V

Semiconductor Device, Diodes

D552	*152-0185-00			Silicon	Replaceable by 1N4152
D555	*152-0185-00			Silicon	Replaceable by 1N4152
D556	*152-0185-00			Silicon	Replaceable by 1N4152
D559	152-0217-00			Zener	1N756A 8.2 V, 0.4 W, 5%
D884	*152-0061-00			Silicon	Tek Spec
D911	*152-0185-00			Silicon	Replaceable by 1N4152
D940	152-0192-00			Rectifier	VARO 7701-5X
D951	152-0408-00	X44360		Silicon	10,000 V, 5 mA
D952	152-0192-00			Rectifier	VARO 7701-5X
D961	152-0408-00	X44360		Silicon	10,000 V, 5 mA
D1112A,B,C,D	152-0198-00			Silicon	MR1032A (Motorola)
D1142A,B,C,D	152-0198-00			Silicon	MR1032A (Motorola)
D1172A,B,C,D	152-0066-00			Silicon	1N3194
D1202	152-0066-00			Silicon	1N3194
D1212	152-0066-00			Silicon	1N3194

Fuses

F937	159-0021-00			2A 3AG Fast-Blo
F1101	159-0021-00			2A 3AG Fast-Blo
F1102	159-0022-00			1A 3AG Fast-Blo
F1172	159-0025-00	20000	39319X	1/2A 3AG Fast-Blo
F1204	159-0028-00			1/4A 3AG Fast-Blo
F1437	151-0025-00	X39320		1/2A 3AG Fast-Blo

Connectors

J1	131-0352-00			BNC
J101	131-0352-00			BNC
J402	131-0274-00			BNC
J430	131-0352-01			BNC, receptacle, electrical
J529	131-0274-00			BNC
J579	131-0352-01			BNC, receptacle, electrical
J601	131-0352-01			BNC, receptacle, electrical
J729	131-0274-00			BNC

CHASSIS (cont)

Ckt. No.	Tektronix Part No.	Serial/Model No. Eff	Disc	Description
Inductors				
L300	*119-0029-00	20000	31029	Delay Line assembly
L300	*119-0168-00	31030		Delay Line assembly
L884	108-0254-00			600 μ H
L937	*108-0422-00			80 μ H
L980	*108-0321-00			Trace rotation
L989	*108-0295-00			Y Axis alignment
LR367	*108-0328-00			0.3 μ H (wound on a 220 Ω resistor)
LR377	*108-0328-00			0.3 μ H (wound on a 220 Ω resistor)

Transistors

Q364 } Q374 }	*153-0524-00			Silicon	Tek Spec (matched pair)
Q884	*151-0124-00			Silicon	Selected from 2N3119
Q894	*151-0124-00			Silicon	Selected from 2N3119
Q930	*151-0140-00			Silicon	Selected from 2N3055
Q1133	*151-0136-00	20000	43319	Silicon	Replaceable by 2N3053
Q1133	*151-0136-02	43320		Silicon	Replaceable by 2N3053
Q1137	*151-0140-00			Silicon	Selected from 2N3055
Q1163	*151-0136-00	20000	43319	Silicon	Replaceable by 2N3053
Q1163	*151-0136-02	43320		Silicon	Replaceable by 2N3053
Q1167	*151-0140-00			Silicon	Selected from 2N3055
Q1197	151-0149-00			Silicon	2N3441

Resistors

Resistors are fixed, composition, $\pm 10\%$ unless otherwise indicated.

R2	315-0105-00		1 M Ω	$\frac{1}{4}$ W		5%
R3	317-0620-00		62 Ω	$\frac{1}{8}$ W		5%
R6C	322-0643-00		600 k Ω	$\frac{1}{4}$ W	Prec	1%
R6E	322-0644-00		666.6 k Ω	$\frac{1}{4}$ W	Prec	1%
R6F	315-0220-00		22 Ω	$\frac{1}{4}$ W		5%
R7C	322-0620-00		800 k Ω	$\frac{1}{4}$ W	Prec	1%
R7E	321-0618-00		250 k Ω	$\frac{1}{8}$ W	Prec	1%
R7F	315-0470-00		47 Ω	$\frac{1}{4}$ W		5%
R8C	322-0621-01		900 k Ω	$\frac{1}{4}$ W	Prec	$\frac{1}{2}\%$
R8E	321-1389-01		111 k Ω	$\frac{1}{8}$ W	Prec	$\frac{1}{2}\%$

CHASSIS (cont)

Ckt. No.	Tektronix Part No.	Serial/Model No. Eff	No. Disc	Description		
Resistors (cont)						
R8F	315-0560-00			56 Ω	1/4 W	5%
R9C	322-0624-01			990 kΩ	1/4 W	Prec 1/2%
R9E	321-1289-01			10.1 kΩ	1/8 W	Prec 1/2%
R9F	315-0620-00			62 Ω	1/4 W	5%
R13	317-0220-00			22 Ω	1/8 W	5%
R30	311-0326-00			10 kΩ, Var		
R40	311-0546-00	20000	37999	10 kΩ, Var		
R40	*311-0994-00	38000		2.5 kΩ, Var		
R43E	315-0302-00	20000	38689X	3 kΩ	1/4 W	5%
R44B	315-0133-00	20000	38689X	13 kΩ	1/4 W	5%
R71	321-0111-00			140 Ω	1/8 W	Prec 1%
R73	315-0102-00			1 kΩ	1/4 W	5%
R74	316-0103-00			10 kΩ	1/4 W	
R75 ²	311-0385-00	20000	23009	250 Ω, Var		
R75 ²	311-0385-01	23010	28659	250 Ω, Var		
R75 ²	311-0385-00	28660		250 Ω, Var		
R76	321-0114-00			150 Ω	1/8 W	Prec 1%
R77	316-0154-00			150 kΩ	1/4 W	
R78	316-0106-00	X23169		10 MΩ	1/4 W	
R81	321-0055-00			36.5 Ω	1/8 W	Prec 1%
R90	311-0169-00			100 Ω, Var		
R91	321-0017-00			14.7 Ω	1/8 W	Prec 1%
R102	315-0105-00			1 MΩ	1/4 W	5%
R103	317-0620-00			62 Ω	1/8 W	5%
R106C	322-0643-00			600 kΩ	1/4 W	Prec 1%
R106E	322-0644-00			666.6 kΩ	1/4 W	Prec 1%
R106F	315-0220-00			22 Ω	1/4 W	5%
R107C	322-0620-00			800 kΩ	1/4 W	Prec 1%
R107E	321-0618-00			250 kΩ	1/8 W	Prec 1%
R107F	315-0470-00			47 Ω	1/4 W	5%
R108C	322-0621-01			900 kΩ	1/4 W	Prec 1/2%
R108E	321-1389-01			111 kΩ	1/8 W	Prec 1/2%
R108F	315-0560-00			56 Ω	1/4 W	5%
R109C	322-0624-01			990 kΩ	1/4 W	Prec 1/2%
R109E	321-1289-01			10.1 kΩ	1/8 W	Prec 1/2%
R109F	315-0620-00			62 Ω	1/4 W	5%
R113	317-0220-00			22 Ω	1/8 W	5%
R130	311-0326-00			10 kΩ, Var		
R140	311-0546-00	20000	37999	10 kΩ, Var		
R140	*311-0994-00	38000		2.5 kΩ, Var		
R143E	315-0302-00	20000	38689X	3 kΩ	1/4 W	5%
R144B	315-0133-00	20000	38689X	13 kΩ	1/4 W	5%

²Furnished as a unit with 575.

CHASSIS (cont)

Ckt. No.	Tektronix Part No.	Serial/Model Eff	No. Disc	Description		
Resistors (cont)						
R171	321-0111-00			140 Ω	$\frac{1}{8}$ W	Prec 1%
R173	315-0102-00			1 k Ω	$\frac{1}{4}$ W	5%
R174	316-0103-00			10 k Ω	$\frac{1}{4}$ W	
R175 ³	311-0385-00	20000	23009	250 Ω , Var		
R175 ³	311-0385-01	23010	28659	250 Ω , Var		
R175 ³	311-0385-00	28660		250 Ω , Var		
R176	321-0114-00			150 Ω	$\frac{1}{8}$ W	Prec 1%
R177	316-0154-00			150 k Ω	$\frac{1}{4}$ W	
R178	316-0106-00	X23169		10 M Ω	$\frac{1}{4}$ W	
R181	321-0055-00			36.5 Ω	$\frac{1}{8}$ W	Prec 1%
R190	311-0169-00			100 Ω , Var		
R191	321-0017-00			14.7 Ω	$\frac{1}{8}$ W	Prec 1%
R364	*310-0623-00			650 Ω	4 W	Prec 1%
R365	316-0100-00			10 Ω	$\frac{1}{4}$ W	
R374	*310-0623-00			650 Ω	4 W	Prec 1%
R400	316-0154-00			150 k Ω	$\frac{1}{4}$ W	
R401	316-0154-00			150 k Ω	$\frac{1}{4}$ W	
R402	321-0097-00			100 Ω	$\frac{1}{8}$ W	Prec 1%
R403	321-0097-00			100 Ω	$\frac{1}{8}$ W	Prec 1%
R430	316-0100-00			10 Ω	$\frac{1}{4}$ W	
R433B	301-0914-00			910 k Ω	$\frac{1}{2}$ W	5%
R433C	301-0114-00			110 k Ω	$\frac{1}{2}$ W	5%
R435	315-0104-00			100 k Ω	$\frac{1}{4}$ W	5%
R436	315-0104-00			100 k Ω	$\frac{1}{4}$ W	5%
R460 ⁴	311-0553-00			10 k Ω , Var		
R528	316-0106-00	X23169		10 M Ω	$\frac{1}{4}$ W	
R530A	323-0400-00			143 k Ω	$\frac{1}{2}$ W	Prec 1%
R530B	323-0371-00			71.5 k Ω	$\frac{1}{2}$ W	Prec 1%
R530C	323-0371-00			71.5 k Ω	$\frac{1}{2}$ W	Prec 1%
R530D	323-0371-00			71.5 k Ω	$\frac{1}{2}$ W	Prec 1%
R530E	315-0335-00			3.3 M Ω	$\frac{1}{4}$ W	5%
R530F	309-0095-00	20000	33249	10 M Ω	$\frac{1}{2}$ W	Prec 1%
R530F	323-0577-00	33250	40059	10 M Ω	$\frac{1}{2}$ W	Prec 1%
R530F	325-0072-00	40060		10 M Ω	1 W	Prec 1%
R530G	309-0454-00	20000	33249	11.5 M Ω	$\frac{1}{2}$ W	Prec 1%
R530G	323-0583-00	33250	40059	11.5 M Ω	$\frac{1}{2}$ W	Prec 1%
R530G	325-0077-00	40060		11.5 M Ω	1 W	Prec 1%
R530H	309-0453-00	20000	33249	7.15 M Ω	$\frac{1}{2}$ W	Prec 1%
R530H	323-0563-00	33250	40059	7.15 M Ω	$\frac{1}{2}$ W	Prec 1%
R530H	325-0075-00	40060		7.15 M Ω	1 W	Prec 1%
R530J	309-0452-00	20000	33249	3.57 M Ω	$\frac{1}{2}$ W	Prec 1%
R530J	323-0534-00	33250	40059	3.57 M Ω	$\frac{1}{2}$ W	Prec 1%
R530J	325-0073-00	40060		3.57 M Ω	1 W	Prec 1%
R530K	323-0712-00			1.43 M Ω	$\frac{1}{2}$ W	Prec $\frac{1}{2}$ %
R530L	323-0710-00			715 k Ω	$\frac{1}{2}$ W	Prec $\frac{1}{2}$ %

³Furnished as a unit with S175.⁴Furnished as a unit with R551.

CHASSIS (cont)

Ckt. No.	Tektronix Part No.	Serial/Model No. Eff	No. Disc	Description		
Resistors (cont)						
R530M	323-0710-00			715 kΩ	1/2 W	Prec 1/2%
R530N	323-0711-00			715 kΩ	1/2 W	Prec 1/10%
R530W	316-0154-00			150 kΩ	1/4 W	
R530X	315-0272-00			2.7 kΩ	1/4 W	5%
R530Y ⁵	311-0554-00			20 kΩ, Var		
R532	301-0221-00			220 Ω	1/2 W	5%
R551 ⁶	311-0553-00			10 kΩ, Var		
R552	323-0381-00			90.9 kΩ	1/2 W	Prec 1%
R555	311-0547-00	20000	32659	10 kΩ, Var		
R555	311-0191-00	32660		10 kΩ, Var		
R558	323-0353-00			46.4 kΩ	1/2 W	Prec 1%
R569	302-0104-00			100 kΩ	1/2 W	
R601	316-0100-00			10 Ω	1/4 W	
R613B	301-0914-00			910 kΩ	1/2 W	5%
R613C	301-0114-00			110 kΩ	1/2 W	5%
R615	315-0104-00			100 kΩ	1/4 W	5%
R616	315-0104-00			100 kΩ	1/4 W	5%
R660	311-0555-00			10 kΩ, Var		
R740A	323-0400-00			143 kΩ	1/2 W	Prec 1%
R740B	323-0371-00			71.5 kΩ	1/2 W	Prec 1%
R740C	323-0371-00			71.5 kΩ	1/2 W	Prec 1%
R740D	323-0371-00			71.5 kΩ	1/2 W	Prec 1%
R740E	315-0335-00			3.3 MΩ	1/4 W	5%
R740F	309-0095-00	20000	33249	10 MΩ	1/2 W	Prec 1%
R740F	323-0577-00	33250	40059	10 MΩ	1/2 W	Prec 1%
R740F	325-0072-00	40060		10 MΩ	1 W	Prec 1%
R740G	309-0454-00	20000	33249	11.5 MΩ	1/2 W	Prec 1%
R740G	323-0583-00	33250	40059	11.5 MΩ	1/2 W	Prec 1%
R740G	325-0077-00	40060		11.5 MΩ	1 W	Prec 1%
R740H	309-0453-00	20000	33249	7.15 MΩ	1/2 W	Prec 1%
R740H	323-0563-00	33250	40059	7.15 MΩ	1/2 W	Prec 1%
R740H	325-0075-00	40060		7.15 MΩ	1 W	Prec 1%
R740J	309-0452-00	20000	33249	3.57 MΩ	1/2 W	Prec 1%
R740J	323-0534-00	33250	40059	3.57 MΩ	1/2 W	Prec 1%
R740J	325-0073-00	40060		3.57 MΩ	1 W	Prec 1%
R740K	323-0712-00			1.43 MΩ	1/2 W	Prec 1/2%
R740L	323-0710-00			715 kΩ	1/2 W	Prec 1/2%
R740M	323-0710-00			715 kΩ	1/2 W	Prec 1/2%
R740N	323-0711-00			715 kΩ	1/2 W	Prec 1/10%
R740P	315-0332-00			3.3 kΩ	1/4 W	5%
R740X	315-0272-00			2.7 kΩ	1/4 W	5%
R740Y ⁷	311-0554-00			20 kΩ, Var		
R760	311-0386-00			2 kΩ, Var		

⁵Furnished as a unit with S530Y.

⁶Furnished as a unit with R460.

⁷Furnished as a unit with S740Y.

CHASSIS (cont)

Ckt. No.	Tektronix Part No.	Serial/Model No. Eff	No. Disc	Description		
Resistors (cont)						
R801	321-0286-00			9.31 k Ω	1/8 W	Prec 1%
R802	321-0286-00			9.31 k Ω	1/8 W	Prec 1%
R805A,B	311-0542-01			10 k Ω x 50 k Ω , Var		
R808	315-0822-00			8.2 k Ω	1/4 W	5%
R849	316-0154-00			150 k Ω	1/4 W	
R884	308-0363-00			3 k Ω	8 W	WW 5%
R886	305-0471-00			470 Ω	2 W	5%
R887	308-0092-00			4.5 k Ω	5 W	WW 5%
R894	308-0363-00			3 k Ω	8 W	WW 5%
R902	301-0105-00			1 M Ω	1/2 W	5%
R903	301-0305-00			3 M Ω	1/2 W	5%
R904	301-0305-00			3 M Ω	1/2 W	5%
R905	301-0305-00			3 M Ω	1/2 W	5%
R906	301-0305-00			3 M Ω	1/2 W	5%
R907	301-0305-00			3 M Ω	1/2 W	5%
R908	301-0305-00			3 M Ω	1/2 W	5%
R909	301-0305-00			3 M Ω	1/2 W	5%
R910	301-0305-00			3 M Ω	1/2 W	5%
R911	315-0204-00			200 k Ω	1/4 W	5%
R940	311-0549-00			1 M Ω , Var		
R941	315-0154-00			150 k Ω	1/4 W	5%
R942	315-0183-00			18 k Ω	1/4 W	5%
R944	301-0565-00			5.6 M Ω	1/2 W	5%
R945	301-0565-00			5.6 M Ω	1/2 W	5%
R946	301-0565-00			5.6 M Ω	1/2 W	5%
R947	301-0565-00			5.6 M Ω	1/2 W	5%
R948	301-0565-00			5.6 M Ω	1/2 W	5%
R951	308-0427-00	20000	35889	9.3 Ω	1/2 W	WW 1%
R951	308-0589-00	35890		11 Ω	1/2 W	WW 1%
R956	316-0103-00			10 k Ω	1/4 W	
R961	316-0105-00			1 M Ω	1/4 W	
R962	316-0105-00			1 M Ω	1/4 W	
R963	301-0335-00			3.3 M Ω	1/2 W	5%
R964	301-0335-00			3.3 M Ω	1/2 W	5%
R965	301-0335-00			3.3 M Ω	1/2 W	5%
R966	301-0335-00			3.3 M Ω	1/2 W	5%
R967	311-0254-00			5 M Ω , Var		
R968	301-0155-00			1.5 M Ω	1/2 W	5%
R969	301-0106-00			10 M Ω	1/2 W	5%
R971	315-0332-00			3.3 k Ω	1/4 W	5%
R972	301-0682-00			6.8 k Ω	1/2 W	5%
R975	316-0223-00			22 k Ω	1/4 W	
R976	316-0101-00			100 Ω	1/4 W	
R979	315-0471-00			470 Ω	1/4 W	5%

CHASSIS (cont)

Ckt. No.	Tektronix Part No.	Serial/Model No. Eff	No. Disc	Description		
Resistors (cont)						
R980	311-0458-00			5 kΩ, Var		
R985	311-0157-00			100 kΩ, Var		
R989	311-0458-00			5 kΩ, Var		
R1003	316-0123-00			12 kΩ	1/4 W	
R1005	311-0511-00			10 kΩ, Var		
R1104	316-0153-00			15 kΩ	1/4 W	
R1105	316-0472-00			4.7 kΩ	1/4 W	
R1106	316-0102-00			1 kΩ	1/4 W	
R1107	316-0330-00			33 Ω	1/4 W	
R1108	311-0548-00			25 Ω, Var		
R1112	316-0103-00			10 kΩ	1/4 W	
R1137	308-0362-00			50 Ω	10 W	WW 5%
R1142	316-0103-00			10 kΩ	1/4 W	
R1167	308-0362-00			50 Ω	10 W	WW 5%
R1172	316-0104-00			100 kΩ	1/4 W	
R1191	308-0153-00			100 Ω	10 W	WW 5%
R1197	308-0153-00			100 Ω	10 W	WW 5%
R1200	308-0071-00	X30720	39319X	500 Ω	5 W	WW 1%
R1202	316-0104-00			100 kΩ	1/4 W	
R1204	302-0270-00			27 Ω	1/2 W	
R1275	322-0655-00			180 Ω	1/4 W	Prec 1/4%
R1276	321-0702-00			30 Ω	1/8 W	Prec 1/4%
R1277	321-0704-00			60 Ω	1/8 W	Prec 1/2%

Switches

Wired or Unwired

SW1	260-0621-00			Lever	AC-GND-DC
SW5	Wired *262-0728-01	20000	22529	Rotary	CH 1 VOLTS/DIV
SW5	Wired *262-0728-02	22530	43319X	Rotary	CH 1 VOLTS/DIV
SW5	260-0720-01			Rotary	CH 1 VOLTS/DIV
SW75 ⁸	311-0385-00	20000	23009		CH 1 CAL
SW75 ⁸	311-0385-01	23010	28659		CH 1 CAL
SW75 ⁸	311-0385-00	28660			CH 1 CAL
SW101	260-0621-00			Lever	AC-GND-DC
SW105	Wired *262-0728-01	20000	22529	Rotary	CH 2 VOLTS/DIV
SW105	Wired *262-0728-02	22530	43319X	Rotary	CH 2 VOLTS/DIV
SW105	260-0720-01			Rotary	CH 2 VOLTS/DIV
SW175 ⁹	311-0385-00	20000	23009		CH 2 CAL
SW175 ⁹	311-0385-01	23010	28659		CH 2 CAL
SW175 ⁹	311-0385-00	28660			CH 2 CAL

⁸Furnished as a unit with R75.

⁹Furnished as a unit with R175.

CHASSIS (cont)

Ckt. No.	Tektronix Part No.	Serial/Model No. Eff	No. Disc		Description	
Switches (cont)						
Wired or Unwired						
SW230A } SW230B }	Wired	*262-0727-01			Rotary	MODE TRIGGER
SW230A } SW230B }		260-0695-01			Rotary	MODE TRIGGER
SW330		260-0688-00			Push	TRACE FINDER
SW430 } SW435 }	Wired	*262-0723-00	20000	43319X	Lever	A SOURCE A COUPLING
SW430		260-0698-01			Lever	A SOURCE
SW435		260-0700-00			Lever	A COUPLING
SW455		260-0472-00			Lever	A SLOPE
SW530A,B	Wired	*262-0724-01			Rotary	A AND B TIME/DIV
SW530A,B		260-0694-00			Rotary	A AND B TIME/DIV
SW530Y ¹⁰		311-0554-00				
SW555	Wired	*262-0726-02	20000	43319X	Rotary	A SWEEP LENGTH
SW555		260-0697-01			Rotary	A SWEEP LENGTH
SW569 ¹¹		260-0717-00			Push	RESET
SW580		260-0699-00			Lever	A SWEEP MODE
SW610 } SW615 }	Wired	*262-0723-00	20000	43319X	Lever	B SOURCE B COUPLING
SW610		260-0698-01			Lever	B SOURCE
SW615		260-0700-00			Lever	B COUPLING
SW635		260-0587-00			Lever	B SWEEP MODE
SW655		260-0472-00			Lever	B SLOPE
SW740Y ¹²		311-0554-00				B VARIABLE CAL
SW801A } SW801B }	Wired	*262-0725-02	20000	43319X	Rotary	HORIZ DISPLAY MAG
SW801A } SW801B }		260-0696-00			Rotary	HORIZ DISPLAY MAG
SW1101		260-0834-00			Toggle	POWER
SW1102 ¹³						
SW1103 ¹³						
SW1275		260-0447-00			Slide	CALIBRATOR

Thermal Cut-Out

TK1101 260-0638-00 Opens at 75° ±3°

¹⁰Furnished as a unit with R530Y.¹¹Furnished as a unit with D5597.¹²Furnished as a unit with R740Y.¹³See Mechanical Parts List. Line Voltage Selector Body.

CHASSIS (cont)

Ckt. No.	Tektronix Part No.	Serial/Model Eff	No. Disc	Description
Transformers				
T930	*120-0360-00			H. V. Power
T1101	*120-0470-00	20000	39319	L. V. Power
T1101	*120-0649-00	39320		L. V. Power
Electron Tubes				
V952	154-0051-00	20000	44359X	5642
V962	154-0051-00	20000	44359X	5642
V979	*154-0492-04	20000	32049	T4530-31-1 CRT Standard Phosphor
V979	*154-0566-00	32050		T4531-31-1 CRT Standard Phosphor

Z AXIS Circuit Board Assembly

*670-0414-04

Complete Board

Capacitors

Tolerance $\pm 20\%$ unless otherwise indicated.

C902	285-0703-00	20000	38331	0.1 μF	PTM	100 V	5%
C902	285-0633-00	38332		0.22 μF	PTM	100 V	10%
C913	285-0622-00			0.1 μF	PTM	100 V	
C982	283-0003-00			0.01 μF	Cer	150 V	
C1007	283-0080-00			0.022 μF	Cer	25 V	+80%—20%
C1015	283-0080-00			0.022 μF	Cer	25 V	+80%—20%
C1016	283-0003-00			0.01 μF	Cer	150 V	
C1022	281-0547-00			2.7 pF	Cer	500 V	10%
C1023	283-0080-00			0.022 μF	Cer	25 V	+80%—20%
C1026	283-0080-00			0.022 μF	Cer	25 V	+80%—20%
C1029	283-0083-00			0.0047 μF	Cer	500 V	5%
C1034	283-0092-00			0.03 μF	Cer	200 V	+80%—20%
C1036	281-0064-00			0.25-1.5 pF, Var	Tub.		
C1037	281-0547-00			2.7 pF	Cer	500 V	10%
C1041	283-0092-00			0.03 μF	Cer	200 V	+80%—20%
C1043	283-0092-00			0.03 μF	Cer	200 V	+80%—20%
C1044	283-0092-00			0.03 μF	Cer	200 V	+80%—20%
C1048	283-0080-00			0.022 μF	Cer	25 V	+80%—20%

Semiconductor Device, Diodes

D1015	*152-0153-00			Silicon	Replaceable by 1N4244
D1016	*152-0153-00			Silicon	Replaceable by 1N4244
D1042	*152-0061-00			Silicon	Tek Spec
D1043	152-0126-00	20000	27449	Zener	1N3024A 15 V, 1 W, 10%
D1043	152-0024-00	27450		Zener	1N3024B 15 V, 1 W, 5%
D1044	*152-0061-00			Silicon	Tek Spec
D1045	*152-0185-00			Silicon	Replaceable by 1N4152

Z AXIS Circuit Board Assembly (cont)

Ckt. No.	Tektronix Part No.	Serial/Model No. Eff	Disc	Description
Transistors				
Q913	151-0220-00			Silicon 2N4122
Q914	*151-0126-00			Silicon Replaceable by 2N2484
Q923	*151-0136-00			Silicon Replaceable by 2N3053
Q1014	151-0223-00			Silicon 2N4275
Q1023	151-0223-00	20000	30449	Silicon 2N4275
Q1023	*151-0190-01	30450		Silicon Tek Spec
Q1024	151-0214-00			Silicon 2N3495
Q1034	*151-0124-00			Silicon Selected from 2N3119
Q1043	*151-0096-00	20000	30449	Silicon Selected from 2N1893
Q1043	*151-0124-00	30450		Silicon Selected from 2N3119
Resistors				
Resistors are fixed, composition, $\pm 10\%$ unless otherwise indicated.				
R900	311-0465-00			100 k Ω , Var
R901	301-0435-00			4.3 M Ω 1/2 W 5%
R912	316-0103-00			10 k Ω 1/4 W
R913	316-0102-00			1 k Ω 1/4 W
R915	316-0474-00			470 k Ω 1/4 W
R916	316-0101-00			100 Ω 1/4 W
R917	316-0104-00			100 k Ω 1/4 W
R925	303-0153-00			15 k Ω 1 W 5%
R982	311-0465-00			100 k Ω , Var
R1004	316-0470-00			47 Ω 1/4 W
R1006	315-0123-00			12 k Ω 1/4 W 5%
R1007	315-0123-00			12 k Ω 1/4 W 5%
R1008	321-0241-00			3.16 k Ω 1/8 W Prec 1%
R1011	301-0473-00			47 k Ω 1/2 W 5%
R1012	316-0470-00			47 Ω 1/4 W
R1013	321-0241-00			3.16 k Ω 1/8 W Prec 1%
R1014	316-0471-00			470 Ω 1/4 W
R1015	316-0101-00			100 Ω 1/4 W
R1016	323-0318-00			20 k Ω 1/2 W Prec 1%
R1021	315-0390-00			39 Ω 1/4 W 5%
R1023	315-0221-00			220 Ω 1/4 W 5%
R1024	315-0121-00			120 Ω 1/4 W 5%
R1025	301-0751-00			750 Ω 1/2 W 5%
R1026	316-0470-00			47 Ω 1/4 W
R1029	316-0102-00			1 k Ω 1/4 W
R1033	315-0240-00			24 k Ω 1/4 W 5%
R1034	301-0243-00			24 k Ω 1/2 W 5%
R1036	323-0335-00			30.1 k Ω 1/2 W Prec 1%
R1041	316-0101-00			100 Ω 1/4 W
R1042	305-0183-00			18 k Ω 2 W 5%

Z AXIS Circuit Board Assembly (cont)

Ckt. No.	Tektronix Part No.	Serial/Model No. Eff	Disc	Description		
Resistors (cont)						
R1043	308-0348-00		3.32 k Ω	3 W	WW	1%
R1044	316-0101-00		100 Ω	1/4 W		
R1046	301-0680-00		68 Ω	1/2 W		5%
R1047	305-0822-00		8.2 k Ω	2 W		5%
R1048	316-0101-00		100 Ω	1/4 W		

LOW VOLTAGE REGULATOR Circuit Board Assembly

*670-0415-00

Complete Board

Capacitors

Tolerance $\pm 20\%$ unless otherwise indicated.

C1114	290-0171-00		100 μF	Elect.	12 V	
C1121	290-0162-00		22 μF	Elect.	35 V	
C1128	283-0078-00		0.001 μF	Cer	500 V	
C1151	290-0162-00		22 μF	Elect.	35 V	
C1156	283-0078-00		0.001 μF	Cer	500 V	
C1164	290-0286-00		50 μF	Elect.	25 V	+75%—10%
C1181	290-0198-00		17 μF	Elect.	150 V	+30%—15%
C1184	283-0079-00		0.01 μF	Cer	250 V	
C1185	285-0622-00		0.1 μF	PTM	100 V	
C1194	290-0305-00		3 μF	Elect.	150 V	

Semiconductor Device, Diodes

D1114	152-0212-00			Zener	1N936 9 V, 5% TC
D1152	*152-0185-00			Silicon	Replaceable by 1N4152
D1164	*152-0185-00			Silicon	Replaceable by 1N4152
D1182	*152-0185-00			Silicon	Replaceable by 1N4152
D1185	152-0150-00			Zener	1N3037B 51 V, 1 W, 5%
D1188	*152-0185-00			Silicon	Replaceable by 1N4152
D1189	*152-0185-00			Silicon	Replaceable by 1N4152
D1194	*152-0185-00			Silicon	Replaceable by 1N4152
D1198	152-0066-00			Silicon	1N3194
D1209	152-0213-00	20000	27449	Zener	1N3032 33 V, 1 W, 20%
D1209	152-0293-00	27450		Zener	1N3032B 33 V, 1 W, 5%

Transistors

Q1114	151-0224-00			Silicon	2N3692
Q1124	151-0224-00			Silicon	2N3692
Q1129	151-0224-00			Silicon	2N3692
Q1154	151-0224-00			Silicon	2N3692
Q1159	151-0224-00			Silicon	2N3692

LOW VOLTAGE REGULATOR Circuit Board Assembly (cont)

Ckt. No.	Tektronix Part No.	Serial/Model No. Eff	Disc		Description
Transistors (cont)					
Q1184	151-0224-00			Silicon	2N3692
Q1189	*151-0096-00	20000	30449	Silicon	Selected from 2N1893
Q1189	151-0250-00	30450		Silicon	2N5184
Q1193	*151-0136-00			Silicon	Replaceable by 2N3053

Resistors

Resistors are fixed, composition, $\pm 10\%$ unless otherwise indicated.

R1114	323-0154-00			392 Ω	$\frac{1}{2}$ W	Prec	1%
R1117	301-0273-00			27 k Ω	$\frac{1}{2}$ W		5%
R1119	315-0561-00			560 Ω	$\frac{1}{4}$ W		5%
R1121	323-0212-00			1.58 k Ω	$\frac{1}{2}$ W	Prec	1%
R1122	311-0515-00			250 Ω , Var			
R1123	323-0160-00			453 Ω	$\frac{1}{2}$ W	Prec	1%
R1129	308-0244-00			0.3 Ω	2 W	WW	
R1133	316-0121-00			120 Ω	$\frac{1}{4}$ W		
R1151	323-0210-00			1.5 k Ω	$\frac{1}{2}$ W	Prec	1%
R1152	311-0514-00			100 Ω , Var			
R1153	323-0205-00			1.33 k Ω	$\frac{1}{2}$ W	Prec	1%
R1154	323-0373-00			75 k Ω	$\frac{1}{2}$ W	Prec	1%
R1156	301-0243-00			24 k Ω	$\frac{1}{2}$ W		5%
R1159	308-0244-00			0.3 Ω	2 W	WW	
R1163	316-0121-00			120 Ω	$\frac{1}{4}$ W		
R1164	316-0123-00			12 k Ω	$\frac{1}{4}$ W		
R1181	323-0308-00			15.8 k Ω	$\frac{1}{2}$ W	Prec	1%
R1182	311-0515-00			250 Ω , Var			
R1183	323-0222-00			2 k Ω	$\frac{1}{2}$ W	Prec	1%
R1184	323-0373-00			75 k Ω	$\frac{1}{2}$ W	Prec	1%
R1185	316-0103-00			10 k Ω	$\frac{1}{4}$ W		
R1186	315-0333-00			33 k Ω	$\frac{1}{4}$ W		5%
R1187	307-0093-00			1.2 Ω	$\frac{1}{2}$ W		5%
R1188	316-0470-00			47 Ω	$\frac{1}{4}$ W		
R1189	315-0683-00			68 k Ω	$\frac{1}{4}$ W		5%
R1193	316-0121-00			120 Ω	$\frac{1}{4}$ W		
R1194	316-0823-00			82 k Ω	$\frac{1}{4}$ W		
R1209	301-0123-00			12 k Ω	$\frac{1}{2}$ W		5%

VERT OUTPUT AMP Circuit Board Assembly

Ckt. No.	Tektronix Part No.	Serial/Model No. Eff	Disc	Description
----------	--------------------	----------------------	------	-------------

*670-0416-02

Complete Board

Capacitors

Tolerance $\pm 20\%$ unless otherwise indicated.

C301	281-0503-00			8 pF	Cer	500 V	± 0.5 pF
C302	281-0503-00			8 pF	Cer	500 V	± 0.5 pF
C303	281-0572-00			6.8 pF	Cer	500 V	± 0.5 pF
C306	283-0080-00			0.022 μ F	Cer	25 V	+80%—20%
C311	281-0503-00			8 pF	Cer	500 V	± 0.5 pF
C312	281-0503-00			8 pF	Cer	500 V	± 0.5 pF
C313	281-0572-00			6.8 pF	Cer	500 V	± 0.5 pF
C322	283-0080-00			0.022 μ F	Cer	25 V	+80%—20%
C326	281-0504-00			10 pF	Cer	500 V	10%
C327	281-0572-00			6.8 pF	Cer	500 V	± 0.5 pF
C328	281-0081-00			1.8-13 pF, Var	Air		
C331	283-0080-00			0.022 μ F	Cer	25 V	+80%—20%
C336	281-0081-00			1.8-13 pF, Var	Air		
C340	281-0662-00			10 pF	Cer	500 V	± 0.5 pF
C342	281-0572-00			6.8 pF	Cer	500 V	10%
C344	283-0077-00			330 pF	Cer	500 V	5%
C347	281-0603-00			39 pF	Cer	500 V	5%
C354	283-0077-00			330 pF	Cer	500 V	5%
C361	283-0078-00			0.001 μ F	Cer	500 V	
C371	283-0078-00			0.001 μ F	Cer	500 V	

Semiconductor Device, Diodes

D339	*152-0185-00			Silicon		Replaceable by 1N4152
D344	152-0076-00	20000	27449	Zener		1N4372 3 V, 0.4 W, 10%
D344	152-0278-00	27450		Zener		1N4372A 3 V, 0.4 W, 5%
D354	152-0076-00	20000	27449	Zener		1N4372 3 V, 0.4 W, 10%
D354	152-0278-00	27450		Zener		1N4372A 3 V, 0.4 W, 5%

Inductors

L301	*108-0220-00			0.15 μ H		
L302	*108-0277-00			0.07 μ H		
L311	*108-0220-00			0.15 μ H		
L361	276-0507-00			Core, ferramic suppressor		
L371	276-0507-00			Core, ferramic suppressor		

VERT OUTPUT AMP Circuit Board Assembly (cont)

Ckt. No.	Tektronix Part No.	Serial/Model No. Eff	Disc	Description
Transistors				
Q304	151-0223-00		Silicon	2N4275
Q314	151-0223-00		Silicon	2N4275
Q324	*151-0120-01		Silicon	Tek Spec
Q334	*151-0120-01		Silicon	Tek Spec
Q344	*151-0127-00		Silicon	Selected from 2N2369
Q354	*151-0127-00		Silicon	Selected from 2N2369
Resistors				
Resistors are fixed, composition, $\pm 10\%$ unless otherwise indicated.				
R303	321-0091-00		86.6 Ω	$\frac{1}{8}$ W Prec 1%
R304	322-0097-00		100 Ω	$\frac{1}{4}$ W Prec 1%
R306	323-0054-00		35.7 Ω	$\frac{1}{2}$ W Prec 1%
R313	321-0091-00		86.6 Ω	$\frac{1}{8}$ W Prec 1%
R314	322-0097-00		100 Ω	$\frac{1}{4}$ W Prec 1%
R321	323-0072-00		54.9 Ω	$\frac{1}{2}$ W Prec 1%
R322	323-0060-00		41.2 Ω	$\frac{1}{2}$ W Prec 1%
R323	322-0097-00		100 Ω	$\frac{1}{4}$ W Prec 1%
R324	323-0181-00		750 Ω	$\frac{1}{2}$ W Prec 1%
R325	322-0124-00		191 Ω	$\frac{1}{4}$ W Prec 1%
R328	311-0480-00		500 Ω , Var	
R330	315-0390-00		39 Ω	$\frac{1}{4}$ W 5%
R331	315-0332-00		3.3 k Ω	$\frac{1}{4}$ W 5%
R332	323-0175-00		649 Ω	$\frac{1}{2}$ W Prec 1%
R333	322-0097-00		100 Ω	$\frac{1}{4}$ W Prec 1%
R334	323-0181-00		750 Ω	$\frac{1}{2}$ W Prec 1%
R339	323-0116-00		158 Ω	$\frac{1}{2}$ W Prec 1%
R340	321-0157-00		422 Ω	$\frac{1}{8}$ W Prec 1%
R341	323-0079-00		64.9 Ω	$\frac{1}{2}$ W Prec 1%
R342	321-0069-00		51.1 Ω	$\frac{1}{8}$ W Prec 1%
R343	323-0138-00		267 Ω	$\frac{1}{2}$ W Prec 1%
R344	301-0470-00		47 Ω	$\frac{1}{2}$ W 5%
R347	321-0117-00		162 Ω	$\frac{1}{8}$ W Prec 1%
R348	307-0125-00		500 Ω	Thermal
R353	323-0138-00		267 Ω	$\frac{1}{2}$ W Prec 1%
R354	301-0470-00		47 Ω	$\frac{1}{2}$ W 5%
Transformer				
T357	276-0517-00		Core, powder iron	

A SWEEP Circuit Board Assembly

Ckt. No.	Tektronix Part No.	Serial/Model No. Eff Disc	Description
	*670-0417-02		Complete Board
			Bulb
B568	150-0035-00		Neon, A1D
			Capacitors
Tolerance $\pm 20\%$ unless otherwise indicated.			
C405	283-0080-00	0.022 μF	Cer 25 V +80%—20%
C411	283-0092-00	0.03 μF	Cer 200 V +80%—20%
C413	283-0065-00	0.001 μF	Cer 100 V 5%
C416	283-0080-00	0.022 μF	Cer 25 V +80%—20%
C417	283-0080-00	0.022 μF	Cer 25 V +80%—20%
C421	283-0081-00	0.1 μF	Cer 25 V +80%—20%
C422	283-0080-00	0.022 μF	Cer 25 V +80%—20%
C424	283-0080-00	0.022 μF	Cer 25 V +80%—20%
C440	281-0543-00	270 pF	Cer 500 V 10%
C443	283-0080-00	0.022 μF	Cer 25 V +80%—20%
C456	283-0080-00	0.022 μF	Cer 25 V +80%—20%
C464	283-0080-00	0.022 μF	Cer 25 V +80%—20%
C466	283-0080-00	0.022 μF	Cer 25 V +80%—20%
C467	283-0081-00	0.1 μF	Cer 25 V +80%—20%
C473	281-0519-00	47 pF	Cer 500 V 10%
C476	281-0602-00	68 pF	Cer 500 V 5%
C482	281-0523-00	100 pF	Cer 350 V
C485	290-0246-00	3.3 μF	Elect. 15 V 10%
C493	283-0080-00	0.022 μF	Cer 25 V +80%—20%
C497	283-0092-00	0.03 μF	Cer 200 V +80%—20%
C498	290-0267-00	1 μF	Elect. 35 V
C499	290-0267-00	1 μF	Elect. 35 V
C503	281-0525-00	470 pF	Cer 500 V
C506	281-0525-00	470 pF	Cer 500 V
C509	281-0509-00	15 pF	Cer 500 V 10%
C511	283-0080-00	0.022 μF	Cer 25 V +80%—20%
C512	283-0080-00	0.022 μF	Cer 25 V +80%—20%
C517	281-0519-00	47 pF	Cer 500 V 10%
C523	281-0525-00	470 pF	Cer 500 V
C526	281-0523-00	100 pF	Cer 350 V
C534	283-0080-00	0.022 μF	Cer 25 V +80%—20%
C538	281-0558-00	18 pF	Cer 500 V
C545	290-0135-00	15 μF	Elect. 20 V
C546	283-0078-00	0.001 μF	Cer 500 V
C547	281-0523-00	100 pF	Cer 350 V

A SWEEP Circuit Board Assembly (cont)

Ckt. No.	Tektronix Part No.	Serial/Model No. Eff	Disc	Description		
Capacitors (cont)						
C561	283-0060-00			100 pF	Cer	200 V 5%
C566	281-0525-00			470 pF	Cer	500 V
C568	283-0057-00			0.1 μ F	Cer	200 V +80%—20%
C572	281-0519-00			47 pF	Cer	500 V 10%
C586	283-0080-00			0.022 μ F	Cer	25 V +80%—20%
C597	283-0092-00			0.03 μ F	Cer	200 V +80%—20%
C598	290-0135-00			15 μ F	Elect.	20 V
C599	290-0135-00			15 μ F	Elect.	20 V
C1251	290-0267-00			1 μ F	Elect.	35 V
C1255	285-0595-00			0.1 μ F	PTM	100 V 1%
C1266	283-0010-00			0.05 μ F	Cer	50 V
C1273	281-0519-00			47 pF	Cer	500 V 10%
Semiconductor Device, Diodes						
D408	152-0141-00	20000	30009	Silicon		1N4152
D408	152-0141-02	30010		Silicon		1N4152
D421	152-0166-00			Zener		1N753A 6.2 V, 0.4 W, 5%
D441	152-0246-00			Silicon		Low leakage 40 V, 0.25 W
D449	*152-0185-00			Silicon		Replaceable by 1N4152
D455	152-0185-00			Silicon		Replaceable by 1N4152
D456	*152-0185-00			Silicon		Replaceable by 1N4152
D459	*152-0185-00	20000	20224	Silicon		Replaceable by 1N4152
D459	*152-0185-01	20225	34569	Silicon		Replaceable by 1N4152
D459	*152-0185-00	34570		Silicon		Replaceable by 1N4152
D460	152-0278-00	X20225		Zener		1N437A 3 V, 0.4 W, 5%
D465	*152-0185-00			Silicon		Replaceable by 1N4152
D466	*152-0185-00			Silicon		Replaceable by 1N4152
D474	*152-0153-00			Silicon		Replaceable by 1N4244
D475	*152-0125-00			Tunnel		Selected TD 3A, 4.7 mA
D483	*152-0185-00			Silicon		Replaceable by 1N4152
D484	*152-0185-00			Silicon		Replaceable by 1N4152
D486	*152-0185-00			Silicon		Replaceable by 1N4152
D493	*152-0185-00			Silicon		Replaceable by 1N4152
D501	*152-0153-00			Silicon		Replaceable by 1N4244
D505	*152-0125-00			Tunnel		Selected TD 3A, 4.7 mA
D515	*152-0185-00			Silicon		Replaceable by 1N4152
D517	*152-0185-00			Silicon		Replaceable by 1N4152
D528	*152-0185-00			Silicon		Replaceable by 1N4152
D529	*152-0185-00			Silicon		Replaceable by 1N4152
D533	*152-0249-00			Silicon		Assembly
D542	*152-0185-00			Silicon		Replaceable by 1N4152
D543	*152-0185-00			Silicon		Replaceable by 1N4152
D544	152-0064-00	20000	27449	Zener		1N961 10 V, 0.4 mW, 10%
D544	152-0149-00	27450		Zener		1N961B 10 V, 0.4 mW, 5%

A SWEEP Circuit Board Assembly (cont)

Ckt. No.	Tektronix Part No.	Serial/Model No.		Description
		Eff	Disc	
Semiconductor Device, Diodes (cont)				
D545	*152-0185-00			Replaceable by 1N4152
D546	*152-0185-00			Replaceable by 1N4152
D547	*152-0185-00			Replaceable by 1N4152
D566	*152-0185-00			Replaceable by 1N4152
D575	*152-0185-00			Replaceable by 1N4152
D583	*152-0185-00			Replaceable by 1N4152
D584	*152-0185-00			Replaceable by 1N4152
D591	*152-0185-00			Replaceable by 1N4152
D592	*152-0185-00			Replaceable by 1N4152
D593	*152-0185-00			Replaceable by 1N4152
D594	*152-0185-00			Replaceable by 1N4152
D595	*152-0185-00			Replaceable by 1N4152

Inductors

L459	276-0528-00	20000	20224X	Core, ferramic suppressor
L469	*108-0181-01			0.2 μ H
L484	*120-0382-00			Toroid, 14 turns single
L498	276-0507-00			Core, ferramic suppressor
L499	276-0507-00			Core, ferramic suppressor
L536	276-0507-00			Core, ferramic suppressor
L598	276-0507-00			Core, ferramic suppressor
L599	276-0507-00			Core, ferramic suppressor
LR459	*108-0487-00	X20225		0.27 μ H (wound on a 33 Ω resistor)

Transistors

Q404	151-0225-00			Silicon	2N3563
Q413	151-0223-00			Silicon	2N4275
Q414	151-0223-00			Silicon	2N4275
Q423	*151-0133-00			Silicon	Selected from 2N3251
Q443	*151-1005-00			Silicon	FET, Tek Spec
Q453	151-0223-00			Silicon	2N4275
Q454	151-0223-00			Silicon	2N4275
Q464	151-0223-00			Silicon	2N4275
Q473	151-0221-00			Silicon	2N4258
Q484	151-0221-00			Silicon	2N4258
Q485	151-0223-00			Silicon	2N4275
Q494	151-0220-00			Silicon	2N4122
Q495	151-0223-00			Silicon	2N4275
Q504	151-0131-00			Germanium	2N964
Q514	151-0223-00			Silicon	2N4275
Q524	151-0223-00			Silicon	2N4275
Q531	151-0223-00			Silicon	2N4275

A SWEEP Circuit Board Assembly (cont)

Ckt. No.	Tektronix Part No.	Serial/Model No. Eff	Disc		Description
Transistors (cont)					
Q533	*151-1005-00	20000	30719	Silicon	FET, Tek Spec
Q533	*153-0570-00	30720		Silicon	FET, selected
Q543	151-0220-00			Silicon	2N4122
Q544	151-0220-00			Silicon	2N4122
Q564	151-0220-00			Silicon	2N4122
Q575	151-0220-00			Silicon	2N4122
Q585	151-0220-00			Silicon	2N4122
Q594	*151-0136-00			Silicon	Replaceable by 2N3053
Q1255	151-0224-00			Silicon	2N3692
Q1265	151-0224-00			Silicon	2N3692
Q1274	151-0220-00			Silicon	2N4122

Resistors

Resistors are fixed, composition, $\pm 10\%$ unless otherwise indicated.

R404	321-0097-00			100 Ω	$\frac{1}{8}$ W	Prec	1%
R405	316-0101-00			100 Ω	$\frac{1}{4}$ W		
R406	321-0227-00			2.26 k Ω	$\frac{1}{8}$ W	Prec	1%
R407	321-0064-00			45.3 Ω	$\frac{1}{8}$ W	Prec	1%
R408	321-0077-00			61.9 Ω	$\frac{1}{8}$ W	Prec	1%
R409	321-0212-00			1.58 k Ω	$\frac{1}{8}$ W	Prec	1%
R411	316-0471-00			470 Ω	$\frac{1}{4}$ W		
R412	308-0286-00			8.2 k Ω	3 W	WW	5%
R413	316-0101-00			100 Ω	$\frac{1}{4}$ W		
R416	316-0101-00			100 Ω	$\frac{1}{4}$ W		
R417	315-0471-00			470 Ω	$\frac{1}{4}$ W		5%
R419	321-0210-00			1.5 k Ω	$\frac{1}{8}$ W	Prec	1%
R421	315-0103-00			10 k Ω	$\frac{1}{4}$ W		5%
R422	316-0100-00			10 Ω	$\frac{1}{4}$ W		
R424	316-0221-00			220 Ω	$\frac{1}{4}$ W		
R427	315-0910-00			91 Ω	$\frac{1}{4}$ W		5%
R429	315-0910-00			91 Ω	$\frac{1}{4}$ W		5%
R438	315-0223-00			22 k Ω	$\frac{1}{4}$ W		5%
R439	301-0105-00			1 M Ω	$\frac{1}{2}$ W		5%
R440	301-0105-00			1 M Ω	$\frac{1}{2}$ W		5%
R441	316-0101-00			100 Ω	$\frac{1}{4}$ W		
R443	315-0561-00			560 Ω	$\frac{1}{4}$ W		5%
R447	315-0113-00			11 k Ω	$\frac{1}{4}$ W		5%
R451	315-0392-00			3.9 k Ω	$\frac{1}{4}$ W		5%
R452	316-0270-00			27 Ω	$\frac{1}{4}$ W		
R458	315-0112-00			1.1 k Ω	$\frac{1}{4}$ W		5%
R459	315-0560-00			56 Ω	$\frac{1}{4}$ W		5%
R461	315-0162-00	20000	20224	1.6 k Ω	$\frac{1}{4}$ W		5%
R461	315-0152-00	20225		1.5 k Ω	$\frac{1}{4}$ W		5%

A SWEEP Circuit Board Assembly (cont)

Ckt. No.	Tektronix Part No.	Serial/Model No. Eff	Disc	Description	
Resistors (cont)					
R462	311-0496-00			2.5 k Ω , Var	
R463	315-0112-00			1.1 k Ω	5%
R464	315-0561-00			560 Ω	5%
R465	316-0270-00			27 Ω	
R466	315-0682-00	X20225		6.8 k Ω	5%
R467	315-0301-00			300 Ω	5%
R468	315-0510-00			51 Ω	5%
R469	315-0271-00			270 Ω	5%
R472	316-0470-00			47 Ω	
R473	315-0243-00			24 k Ω	5%
R474	315-0220-00			22 Ω	5%
R476	315-0201-00			200 Ω	5%
R477	315-0392-00			3.9 k Ω	5%
R481	316-0101-00			100 Ω	
R482	316-0270-00			27 Ω	
R483	301-0183-00			18 k Ω	5%
R484	315-0153-00			15 k Ω	5%
R485	315-0152-00			1.5 k Ω	5%
R486	315-0104-00			100 k Ω	5%
R490	315-0271-00			270 Ω	5%
R492	315-0123-00			12 k Ω	5%
R493	316-0470-00			47 Ω	
R494	315-0104-00			100 k Ω	5%
R495	315-0102-00			1 k Ω	5%
R496	315-0222-00			2.2 k Ω	5%
R502	316-0101-00			100 Ω	
R503	315-0201-00			200 Ω	5%
R506	315-0391-00			390 Ω	5%
R508	315-0202-00			2 k Ω	5%
R509	315-0821-00			820 Ω	5%
R511	315-0620-00			62 Ω	5%
R512	316-0470-00			47 Ω	
R513	321-0143-00			301 Ω	Prec 1%
R514	315-0122-00			1.2 k Ω	5%
R515	323-0301-00			13.3 k Ω	Prec 1%
R517	315-0222-00			2.2 k Ω	5%
R519	321-0277-00			7.5 k Ω	Prec 1%
R521	321-0184-00			806 Ω	Prec 1%
R522	321-0234-00			2.67 k Ω	Prec 1%
R523	316-0470-00			47 Ω	

A SWEEP Circuit Board Assembly (cont)

Ckt. No.	Tektronix Part No.	Serial/Model No. Eff Disc	Description		
Resistors (cont)					
R524	315-0122-00	1.2 k Ω	1/4 W		5%
R529	315-0331-00	330 Ω	1/4 W		5%
R533	316-0101-00	100 Ω	1/4 W		
R534	316-0101-00	100 Ω	1/4 W		
R535	315-0123-00	12 k Ω	1/4 W		5%
R536	316-0101-00	100 Ω	1/4 W		
R538	321-0259-00	4.87 k Ω	1/8 W	Prec	1%
R539	308-0307-00	5 k Ω	3 W	WW	1%
R540	315-0150-00	15 Ω	1/4 W		5%
R541	316-0101-00	100 Ω	1/4 W		
R544	303-0822-00	8.2 k Ω	1 W		5%
R546	316-0101-00	100 Ω	1/4 W		
R547	315-0331-00	330 Ω	1/4 W		5%
R549	316-0101-00	100 Ω	1/4 W		
R561	321-0268-00	6.04 k Ω	1/8 W	Prec	1%
R562	321-0182-00	768 Ω	1/8 W	Prec	1%
R564	316-0473-00	47 k Ω	1/4 W		
R566	315-0223-00	22 k Ω	1/4 W		5%
R567	316-0472-00	4.7 k Ω	1/4 W		
R568	316-0106-00	10 M Ω	1/4 W		
R574	321-0248-00	3.74 k Ω	1/8 W	Prec	1%
R575	321-0188-00	887 Ω	1/8 W	Prec	1%
R582	321-0200-00	1.18 k Ω	1/8 W	Prec	1%
R583	321-0114-00	150 Ω	1/8 W	Prec	1%
R585	321-0327-00	24.9 k Ω	1/8 W	Prec	1%
R586	316-0470-00	47 Ω	1/4 W		
R587	321-0266-00	5.76 k Ω	1/8 W	Prec	1%
R588	321-0268-00	6.04 k Ω	1/8 W	Prec	1%
R592	315-0512-00	5.1 k Ω	1/4 W		5%
R593	315-0512-00	5.1 k Ω	1/4 W		5%
R594	316-0473-00	47 k Ω	1/4 W		
R596	302-0820-00	82 Ω	1/2 W		
R1251	315-0120-00	12 Ω	1/4 W		5%
R1254	316-0471-00	470 Ω	1/4 W		
R1255	315-0472-00	4.7 k Ω	1/4 W		5%
R1264	316-0222-00	2.2 k Ω	1/4 W		
R1265	315-0682-00	6.8 k Ω	1/4 W		5%
R1266	316-0471-00	470 Ω	1/4 W		
R1274	321-0649-00	2.19 k Ω	1/8 W	Prec	1/4%
Transformers					
T474	*120-0361-00		Toroid, 9 turns bifilar		
T1255	*120-0460-00		Calibrator frequency		

B SWEEP Circuit Board Assembly

Ckt. No.	Tektronix Part No.	Serial/Model No. Eff	Disc	Description
*670-0418-02		Complete Board		
Capacitors				
Tolerance $\pm 20\%$ unless otherwise indicated.				
C629	281-0543-00		270 pF	Cer 500 V 10%
C633	283-0080-00		0.022 μ F	Cer 25 V +80%—20%
C636	283-0080-00		0.022 μ F	Cer 25 V +80%—20%
C639	283-0080-00		0.022 μ F	Cer 25 V +80%—20%
C642	283-0080-00		0.022 μ F	Cer 25 V +80%—20%
C656	283-0080-00		0.022 μ F	Cer 25 V +80%—20%
C664	283-0080-00		0.022 μ F	Cer 25 V +80%—20%
C666	283-0080-00		0.022 μ F	Cer 25 V +80%—20%
C667	283-0081-00		0.1 μ F	Cer 25 V +80%—20%
C673	281-0519-00		47 pF	Cer 500 V 10%
C676	281-0540-00		51 pF	Cer 500 V 5%
C688	281-0602-00		68 pF	Cer 500 V 5%
C698	290-0267-00		1 μ F	Elect. 35 V
C699	290-0267-00		1 μ F	Elect. 35 V
C702	281-0580-00		470 pF	Cer 500 V 10%
C704	281-0509-00		15 pF	Cer 500 V 10%
C705	281-0580-00		470 pF	Cer 500 V 10%
C715	283-0080-00		0.022 μ F	Cer 25 V +80%—20%
C722	281-0580-00		470 pF	Cer 500 V 10%
C731	283-0060-00		100 pF	Cer 200 V 5%
C732	283-0080-00		0.022 μ F	Cer 25 V +80%—20%
C744	283-0080-00		0.022 μ F	Cer 25 V +80%—20%
C748	281-0542-00		18 pF	Cer 500 V 10%
C755	283-0078-00		0.001 μ F	Cer 500 V
C756	281-0523-00		100 pF	Cer 350 V
C759	290-0248-01		150 μ F	Elect. 15 V
C768	281-0504-00		10 pF	Cer 500 V 10%
C774	281-0549-00		68 pF	Cer 500 V 10%
C785	281-0519-00		47 pF	Cer 500 V 10%
C786	283-0080-00		0.022 μ F	Cer 25 V +80%—20%
C797	283-0092-00		0.03 μ F	Cer 200 V
C798	290-0135-00		15 μ F	Elect. 20 V
C799	290-0135-00		15 μ F	Elect. 20 V
C804	283-0059-00		1 μ F	Cer 25 V +80%—20%
C806	283-0080-00		0.022 μ F	Cer 25 V +80%—20%
C807	283-0080-00		0.022 μ F	Cer 25 V +80%—20%
C882	281-0064-00		0.25-1.5 pF, Var	Tub.
C892	281-0064-00		0.25-1.5 pF, Var	Tub.
C898	290-0267-00		1 μ F	Elect. 35 V
C899	290-0267-00		1 μ F	Elect. 35 V

B SWEEP Circuit Board Assembly (cont)

Ckt. No.	Tektronix Part No.	Serial/Model No. Eff	Disc		Description
Semiconductor Device, Diodes					
D631	152-0246-00			Silicon	Low leakage 40 V, 0.25 W
D635	*152-0185-00			Silicon	Replaceable by 1N4152
D638	*152-0185-00			Silicon	Replaceable by 1N4152
D641	*152-0185-00			Silicon	Replaceable by 1N4152
D651	*152-0185-00			Silicon	Replaceable by 1N4152
D653	*152-0185-00	20000	20224	Silicon	Replaceable by 1N4152
D653	*152-0185-01	20225	34569	Silicon	Replaceable by 1N4152
D653	*152-0185-00	34570		Silicon	Replaceable by 1N4152
D654	152-0278-00	X20225		Zener	1N4372A, 3 V, 0.4 W, 5%
D655	*152-0185-00			Silicon	Replaceable by 1N4152
D656	*152-0185-00			Silicon	Replaceable by 1N4152
D665	*152-0185-00			Silicon	Replaceable by 1N4152
D666	*152-0185-00			Silicon	Replaceable by 1N4152
D675	*152-0125-00			Tunnel	Selected TD 3A, 4.7 mA
D678	*152-0153-00			Silicon	Replaceable by 1N4244
D701	*152-0153-00			Silicon	Replaceable by 1N4244
D705	*152-0125-00			Tunnel	Selected TD 3A, 4.7 mA
D714	*152-0185-00			Silicon	Replaceable by 1N4152
D727	*152-0185-00			Silicon	Replaceable by 1N4152
D728	*152-0185-00			Silicon	Replaceable by 1N4152
D731	*152-0185-00			Silicon	Replaceable by 1N4152
D742	*152-0249-00			Silicon	Assembly
D748	*152-0185-00			Silicon	Replaceable by 1N4152
D752	*152-0185-00			Silicon	Replaceable by 1N4152
D753	*152-0185-00			Silicon	Replaceable by 1N4152
D754	*152-0185-00			Silicon	Replaceable by 1N4152
D755	*152-0185-00			Silicon	Replaceable by 1N4152
D756	*152-0185-00			Silicon	Replaceable by 1N4152
D764A,B	*152-0151-00			Silicon, assembly matched	pair of 1N4152
D776	*152-0185-00			Silicon	Replaceable by 1N4152
D777	*152-0185-00			Silicon	Replaceable by 1N4152
D783	*152-0185-00			Silicon	Replaceable by 1N4152
D851	*152-0153-00			Silicon	Replaceable by 1N4244
D852	*152-0153-00			Silicon	Replaceable by 1N4244
D861	152-0141-00	20000	30009	Silicon	1N4152
D861	152-0141-02	30010		Silicon	1N4152
D871	152-0141-00	20000	30009	Silicon	1N4152
D871	152-0141-02	30010		Silicon	1N4152
Inductors					
L672	*108-0181-01			0.2 μ H	
L698	276-0507-00			Core, ferramic suppressor	
L699	276-0507-00			Core, ferramic suppressor	
L746	276-0507-00			Core, ferramic suppressor	
L798	276-0507-00			Core, ferramic suppressor	

B SWEEP Circuit Board Assembly (cont)

Ckt. No.	Tektronix Part No.	Serial/Model No. Eff	Disc	Description
----------	--------------------	----------------------	------	-------------

Inductors (cont)

L799	276-0507-00			Core, ferramic suppressor
L898	276-0507-00			Core, ferramic suppressor
L899	276-0507-00			Core, ferramic suppressor
LR653	*108-0487-00	X20225		0.27 μ H (wound on a 33 Ω resistor)

Transistors

Q633	*151-1005-00			Silicon	FET, Tek Spec
Q643	151-0223-00			Silicon	2N4275
Q654	151-0223-00			Silicon	2N4275
Q664	151-0223-00			Silicon	2N4275
Q684	151-0221-00			Silicon	2N4258
Q704	151-0131-00			Germanium	2N964
Q714	151-0223-00			Silicon	2N4275
Q724	151-0223-00			Silicon	2N4275
Q734	151-0223-00			Silicon	2N4275
Q741	151-0223-00			Silicon	2N4275
Q743	*151-1005-00	20000	30719	Silicon	FET, Tek Spec
Q743	*153-0570-00	30720		Silicon	FET, selected
Q753	151-0220-00			Silicon	2N4122
Q754	151-0220-00			Silicon	2N4122
Q764A,B	*151-0104-00			Silicon	Replaceable by 2N2913
Q768	151-0220-00			Silicon	2N4122
Q769	151-0224-00			Silicon	2N3692
Q772	151-0220-00			Silicon	2N4122
Q775	151-0220-00			Silicon	2N4122
Q785	151-0220-00			Silicon	2N4122
Q814	151-0223-00			Silicon	2N4275
Q824	151-0223-00			Silicon	2N4275
Q834	151-0220-00			Silicon	2N4122
Q844	151-0220-00			Silicon	2N4122
Q863	151-0220-00			Silicon	2N4122
Q873	151-0220-00			Silicon	2N4122

Resistors

Resistors are fixed, composition, $\pm 10\%$ unless otherwise indicated.

R531	311-0462-00			1 k Ω , Var		
R627	315-0223-00			22 k Ω	1/4 W	5%
R628	301-0105-00			1 M Ω	1/2 W	5%
R629	301-0105-00			1 M Ω	1/2 W	5%
R631	316-0101-00			100 Ω	1/4 W	
R633	315-0561-00			560 Ω	1/4 W	5%
R634	315-0113-00			11 k Ω	1/4 W	5%
R635	316-0183-00			18 k Ω	1/4 W	
R636	316-0332-00			3.3 k Ω	1/4 W	
R638	315-0183-00			18 k Ω	1/4 W	5%

B SWEEP Circuit Board Assembly (cont)

Ckt. No.	Tektronix Part No.	Serial/Model No. Eff	Disc	Description	
Resistors (cont)					
R639	316-0332-00			3.3 k Ω	1/4 W
R641	315-0183-00			18 k Ω	1/4 W
R642	316-0332-00			3.3 k Ω	1/4 W
R644	321-0289-00			10 k Ω	1/8 W
R645	311-0463-00			5 k Ω , Var	
					Prec
					1%
R646	315-0824-00			820 k Ω	1/4 W
R650	316-0270-00			27 Ω	1/4 W
R653	315-0112-00			1.1 k Ω	1/4 W
R659	315-0560-00			56 Ω	1/4 W
R661	315-0162-00	20000	20224	1.6 k Ω	1/4 W
					5%
R661	315-0152-00	20225		1.5 k Ω	1/4 W
R662	311-0496-00			2.5 k Ω , Var	
R663	315-0112-00			1.1 k Ω	1/4 W
R664	315-0561-00	20000	20224	560 Ω	1/4 W
R664	315-0621-00	20225		620 Ω	1/4 W
					5%
R665	316-0270-00			27 Ω	1/4 W
R666	315-0332-00	X20225		3.3 k Ω	1/4 W
R667	315-0301-00			300 Ω	1/4 W
R671	315-0510-00			51 Ω	1/4 W
R672	315-0271-00			270 Ω	1/4 W
					5%
R674	315-0243-00			24 k Ω	1/4 W
R676	315-0270-00			27 Ω	1/4 W
R677	316-0470-00			47 Ω	1/4 W
R686	315-0220-00			22 Ω	1/4 W
R688	315-0201-00			200 Ω	1/4 W
					5%
R689	315-0392-00			3.9 k Ω	1/4 W
R702	315-0201-00			200 Ω	1/4 W
R704	315-0821-00			820 Ω	1/4 W
R705	315-0391-00			390 Ω	1/4 W
R708	315-0202-00			2 k Ω	1/4 W
					5%
R713	321-0184-00			806 Ω	1/8 W
R714	315-0122-00			1.2 k Ω	1/4 W
R715	315-0620-00			62 Ω	1/4 W
R717	321-0260-00			4.99 k Ω	1/8 W
R718	315-0333-00			33 k Ω	1/4 W
					Prec
					1%
					5%
					5%
					Prec
					1%
R719	315-0823-00			82 k Ω	1/4 W
R721	321-0184-00			806 Ω	1/8 W
R722	321-0234-00			2.67 k Ω	1/8 W
R723	316-0470-00			47 Ω	1/4 W
R724	315-0122-00			1.2 k Ω	1/4 W
					Prec
					Prec
					5%
					1%
					1%
					5%

B SWEEP Circuit Board Assembly (cont)

Ckt. No.	Tektronix Part No.	Serial/Model No. Eff	No. Disc	Description		
Resistors (cont)						
R728	315-0331-00		330 Ω	$\frac{1}{4}$ W		5%
R731	315-0153-00		15 k Ω	$\frac{1}{4}$ W		5%
R733	315-0471-00		470 Ω	$\frac{1}{4}$ W		5%
R734	316-0103-00		10 k Ω	$\frac{1}{4}$ W		
R735	316-0104-00		100 k Ω	$\frac{1}{4}$ W		
R741	311-0462-00		1 k Ω , Var			
R743	316-0101-00		100 Ω	$\frac{1}{4}$ W		
R744	316-0101-00		100 Ω	$\frac{1}{4}$ W		
R745	315-0123-00		12 k Ω	$\frac{1}{4}$ W		5%
R746	316-0101-00		100 Ω	$\frac{1}{4}$ W		
R748	321-0259-00		4.87 k Ω	$\frac{1}{8}$ W	Prec	1%
R749	308-0307-00		5 k Ω	3 W	WW	1%
R750	316-0101-00		100 Ω	$\frac{1}{4}$ W		
R751	315-0150-00		15 Ω	$\frac{1}{4}$ W		5%
R753	316-0101-00		100 Ω	$\frac{1}{4}$ W		
R754	304-0103-00		10 k Ω	1 W		
R755	316-0101-00		100 Ω	$\frac{1}{4}$ W		
R756	315-0331-00		330 Ω	$\frac{1}{4}$ W		5%
R757	323-0299-00		12.7 k Ω	$\frac{1}{2}$ W	Prec	1%
R758	311-0514-00		100 Ω , Var			
R759	321-0126-00		200 Ω	$\frac{1}{8}$ W	Prec	1%
R761	316-0101-00		100 Ω	$\frac{1}{4}$ W		
R763	321-0155-00		402 Ω	$\frac{1}{8}$ W	Prec	1%
R765	301-0822-00		8.2 k Ω	$\frac{1}{2}$ W		5%
R766	315-0122-00		1.2 k Ω	$\frac{1}{4}$ W		5%
R767	315-0361-00		360 Ω	$\frac{1}{4}$ W		5%
R768	315-0682-00		6.8 k Ω	$\frac{1}{4}$ W		5%
R769	321-0245-00		3.48 k Ω	$\frac{1}{8}$ W	Prec	1%
R770	301-0622-00		6.2 k Ω	$\frac{1}{2}$ W		5%
R771	315-0122-00		1.2 k Ω	$\frac{1}{4}$ W		5%
R772	315-0152-00		1.5 k Ω	$\frac{1}{4}$ W		5%
R773	301-0822-00		8.2 k Ω	$\frac{1}{2}$ W		5%
R775	321-0207-00		1.4 k Ω	$\frac{1}{8}$ W	Prec	1%
R776	321-0305-00		14.7 k Ω	$\frac{1}{8}$ W	Prec	1%
R778	321-0333-00		28.7 k Ω	$\frac{1}{8}$ W	Prec	1%
R782	321-0179-00		715 Ω	$\frac{1}{8}$ W	Prec	1%
R783	321-0198-00		1.13 k Ω	$\frac{1}{8}$ W	Prec	1%
R784	321-0231-00		2.49 k Ω	$\frac{1}{8}$ W	Prec	1%
R785	321-0227-00		2.26 k Ω	$\frac{1}{8}$ W	Prec	1%
R786	315-0392-00		3.9 k Ω	$\frac{1}{4}$ W		5%
R787	321-0248-00		3.74 k Ω	$\frac{1}{8}$ W	Prec	1%
R789	316-0101-00		100 Ω	$\frac{1}{4}$ W		
R803	315-0510-00		51 Ω	$\frac{1}{4}$ W		5%
R804	315-0822-00		8.2 k Ω	$\frac{1}{4}$ W		5%
R806	315-0184-00		180 k Ω	$\frac{1}{4}$ W		5%
R807	315-0822-00		8.2 k Ω	$\frac{1}{4}$ W		5%

B SWEEP Circuit Board Assembly (cont)

Ckt. No.	Tektronix Part No.	Serial/Model No. Eff	Disc	Description		
Resistors (cont)						
R809	321-0231-00			2.49 kΩ	1/8 W	Prec 1%
R812	321-0260-00			4.99 kΩ	1/8 W	Prec 1%
R814	304-0103-00			10 kΩ	1 W	
R821	315-0510-00			51 Ω	1/4 W	5%
R822	321-0263-00			5.36 kΩ	1/8 W	Prec 1%
R824	304-0103-00			10 kΩ	1 W	
R826	321-0231-00			2.49 kΩ	1/8 W	Prec 1%
R828	315-0272-00			2.7 kΩ	1/4 W	5%
R831	315-0153-00			15 kΩ	1/4 W	5%
R833	323-0305-00			14.7 kΩ	1/2 W	Prec 1%
R834	322-0216-00			1.74 kΩ	1/4 W	Prec 1%
R835	311-0480-00			500 Ω, Var		
R836	321-0210-00			1.5 kΩ	1/8 W	Prec 1%
R841	315-0153-00			15 kΩ	1/4 W	5%
R843	323-0305-00			14.7 kΩ	1/2 W	Prec 1%
R844	322-0216-00			1.74 kΩ	1/4 W	Prec 1%
R845	311-0433-00			100 Ω, Var		
R846	321-0105-00			121 Ω	1/8 W	Prec 1%
R854	315-0103-00			10 kΩ	1/4 W	5%
R855	311-0541-00			20 kΩ, Var		
R856	315-0103-00			10 kΩ	1/4 W	5%
R862	315-0473-00	20000	30449	47 kΩ	1/4 W	5%
R862	315-0273-00	30450		27 kΩ	1/4 W	5%
R863	316-0122-00			1.2 kΩ	1/4 W	5%
R864	315-0681-00			680 Ω	1/4 W	5%
R872	315-0473-00	20000	30449	47 kΩ	1/4 W	5%
R872	315-0273-00	30450		27 kΩ	1/4 W	5%
R873	316-0122-00			1.2 kΩ	1/4 W	
R874	315-0681-00			680 Ω	1/4 W	5%
R882	323-0322-00			22.1 kΩ	1/2 W	Prec 1%
R892	323-0322-00			22.1 kΩ	1/2 W	Prec 1%

Transformer

T686	*120-0361-00			Toroid, 9 turns bifilar
------	--------------	--	--	-------------------------

VERTICAL PREAMP Circuit Board Assembly

*670-0419-04	20000	32291	Complete Board
*670-0419-06	32292	44711	Complete Board
*670-0419-07	44712		Complete Board

Capacitors

Tolerance ±20% unless otherwise indicated.

C17	281-0064-00	0.25-1.5 pF, Var	Tub.		
C18	283-0077-00	330 pF	Cer	500 V	5%
C20	281-0603-00	39 pF	Cer	500 V	5%
C23	283-0081-00	0.1 μF	Cer	25 V	+80%—20%
C24	290-0177-00	1 μF	Elect.	50 V	

VERTICAL PREAMP Circuit Board Assembly (cont)

Ckt. No.	Tektronix Part No.	Serial/Model No. Eff	Disc	Description			
Capacitors (cont)							
C30	283-0080-00			0.022 μ F	Cer	25 V	+80%—20%
C38	283-0083-00	20000	23009	0.0047 μ F (nominal value)	Selected		
C38	283-0142-00	23010		0.0027 μ F (nominal value)	Selected		
C39	281-0523-00			100 pF	Cer	350 V	
C43A	281-0081-00			1.8-13 pF, Var	Air		
C43B	281-0577-00	20000	44711	14 pF	Cer	500 V	5%
C43B	281-0572-00	44712		6.8 pF	Cer	500 V	\pm 0.5 pF
C43C	281-0081-00			1.8-13 pF, Var	Air		
C43D	281-0510-00			22 pF	Cer	500 V	
C43E	281-0578-00	X38690		18 pF	Cer	500 V	5%
C44A	281-0080-00	20000	44711	1.7-11 pF, Var	Air		
C44A	281-0077-00	44712		1.3-5.4 pF, Var	Air		
C44B	281-0592-00	X38690		4.7 pF	Cer	500 V	\pm 0.5 pF
C44C	281-0080-00			1.7-11 pF, Var	Air		
C45A	281-0080-00			1.7-11 pF, Var	Air		
C49	281-0081-00			1.8-13 pF, Var	Air		
C53	290-0267-00			1 μ F	Elect.	35 V	
C54	281-0077-00			1.3-5.4 pF, Var	Air		
C64	283-0078-00			0.001 μ F	Cer	500 V	
C84	283-0032-00			470 pF	Cer	500 V	5%
C94	283-0032-00			470 pF	Cer	500 V	5%
C95	283-0080-00			0.022 μ F	Cer	25 V	+80%—20%
C96	290-0134-00			22 μ F	Elect.	15 V	
C97	290-0134-00			22 μ F	Elect.	15 V	
C98	283-0092-00			0.03 μ F	Cer	200 V	+80%—20%
C99	283-0092-00			0.03 μ F	Cer	200 V	+80%—20%
C117	281-0064-00			0.25-1.5 pF, Var	Tub.		
C118	283-0077-00			330 pF	Cer	500 V	5%
C120	281-0603-00			39 pF	Cer	500 V	5%
C123	283-0081-00			0.1 μ F	Cer	25 V	+80%—20%
C124	290-0177-00			1 μ F	Elect.	50 V	
C130	283-0080-00			0.022 μ F	Cer	25 V	+80%—20%
C138	283-0083-00	20000	23009	0.0047 μ F (nominal value)	Selected		
C138	283-0142-00	23010		0.0027 μ F (nominal value)	Selected		
C139	281-0523-00			100 pF	Cer	350 V	
C143A	281-0081-00			1.8-13 pF, Var	Air		
C143B	281-0577-00	20000	44711	14 pF	Cer	500 V	5%
C143B	281-0572-00	44712		6.8 pF	Cer	500 V	\pm 0.5 pF
C143C	281-0081-00			1.8-13 pF, Var	Air		
C143D	281-0510-00			22 pF	Cer	500 V	
C143E	281-0578-00	X38690		18 pF	Cer	500 V	5%
C144A	281-0080-00	20000	44711	1.7-11 pF, Var	Air		
C144A	281-0077-00	44712		1.3-5.4 pF, Var	Air		
C144B	281-0592-00	X38690		4.7 pF	Cer	500 V	\pm 0.5 pF
C144C	281-0080-00			1.7-11 pF, Var	Air		
C145A	281-0080-00			1.7-11 pF, Var	Air		
C149	281-0081-00			1.8-13 pF, Var	Air		
C153	290-0267-00			1 μ F	Elect.	35 V	
C154	281-0077-00			1.3-5.4 pF, Var	Air		

VERTICAL PREAMP Circuit Board Assembly (cont)

Ckt. No.	Tektronix Part No.	Serial/Model No. Eff	Disc	Description
Capacitors (cont)				
C159	281-0504-00			10 pF Cer 500 V 10%
C184	283-0032-00			470 pF Cer 500 V 5%
C194	283-0032-00			470 pF Cer 500 V 5%
C197	290-0134-00			22 μ F Elect. 15 V
C198	290-0134-00			22 μ F Elect. 15 V
C199	283-0080-00			0.022 μ F Cer 25 V +80%—20%
C214	281-0510-00			22 pF Cer 500 V
C218	285-0698-00	20000	20644	0.0082 μ F PTM 100 V 5%
C218	285-0598-00	20645	30719	0.01 μ F PTM 100 V 5%
C218	285-0698-00	30720		0.0082 μ F PTM 100 V 5%
C224	281-0510-00			22 pF Cer 500 V
C241	283-0060-00			100 pF Cer 200 V 5%
C253	283-0081-00			0.1 μ F Cer 25 V +80%—20%
C261	283-0060-00			100 pF Cer 200 V 5%
C262	281-0572-00			6.8 pF Cer 500 V 10%
C263	281-0081-00			1.8-13 pF, Var Air
C264	281-0512-00			27 pF (nominal value) Selected
C265	281-0081-00			1.8-13 pF, Var Air
C266	281-0592-00	20000	44711	4.7 pF Cer ± 0.5 pF
C266	281-0604-00	44712		2.2 pF Cer 500 V ± 0.25 pF
C288	281-0505-00			12 pF Cer 500 V 10%
C289	281-0593-00			3.9 pF Cer 10%
C293	283-0081-00			0.1 μ F Cer 25 V +80%—20%
C297	283-0081-00			0.1 μ F Cer 25 V +80%—20%
C298	281-0505-00			12 pF Cer 500 V 10%
C299	283-0081-00			0.1 μ F Cer 25 V +80%—20%

Semiconductor Device, Diodes

D18	*152-0324-00			Silicon	Tek Spec
D34	*152-0185-00			Silicon	Replaceable by 1N4152
D35	*152-0185-00			Silicon	Replaceable by 1N4152
D36	*152-0185-00			Silicon	Replaceable by 1N4152
D37	*152-0185-00			Silicon	Replaceable by 1N4152
D52	*152-0185-00			Silicon	Replaceable by 1N4152
D53	152-0166-00			Zener	1N753A 6.2 V, 0.4 W, 5%
D58	*152-0185-00			Silicon	Replaceable by 1N4152
D118	*152-0324-00			Silicon	Tek Spec
D134	*152-0185-00			Silicon	Replaceable by 1N4152
D135	*152-0185-00			Silicon	Replaceable by 1N4152
D136	*152-0185-00			Silicon	Replaceable by 1N4152
D137	*152-0185-00			Silicon	Replaceable by 1N4152
D152	*152-0185-00			Silicon	Replaceable by 1N4152
D153	152-0166-00			Zener	1N753A 6.2 V, 0.4 W, 5%
D201	152-0141-00	20000	30009	Silicon	1N4152
D201	152-0141-02	30010		Silicon	1N4152
D202	152-0141-00	20000	30009	Silicon	1N4152
D202	152-0141-02	30010		Silicon	1N4152

VERTICAL PREAMP Circuit Board Assembly (cont)

Ckt. No.	Tektronix Part No.	Serial/Model No. Eff	Disc		Description
Semiconductor Device, Diodes (cont)					
D203	152-0141-00	20000	30009	Silicon	1N4152
D203	152-0141-02	30010		Silicon	1N4152
D204	152-0141-00	20000	30009	Silicon	1N4152
D204	152-0141-02	30010		Silicon	1N4152
D206	152-0141-00	20000	30009	Silicon	1N4152
D206	152-0141-02	30010		Silicon	1N4152
D207	152-0141-00	20000	30009	Silicon	1N4152
D207	152-0141-02	30010		Silicon	1N4152
D208	152-0141-00	20000	30009	Silicon	1N4152
D208	152-0141-02	30010		Silicon	1N4152
D209	152-0141-00	20000	30009	Silicon	1N4152
D209	152-0141-02	30010		Silicon	1N4152
D213	*152-0185-00			Silicon	Replaceable by 1N4152
D218	152-0141-00	20000	30009	Silicon	1N4152
D218	152-0141-02	30010		Silicon	1N4152
D223	*152-0185-00			Silicon	Replaceable by 1N4152
D228	152-0141-00	20000	30009	Silicon	1N4152
D228	152-0141-02	30010		Silicon	1N4152
D231	*152-0185-00			Silicon	Replaceable by 1N4152
D233	152-0008-00			Germanium	
D235	*152-0185-00			Silicon	Replaceable by 1N4152
Inductors					
L23	*108-0443-00			25 μ H	
L43A	*114-0170-00			0.15-0.25 μ H, Var	Core 276-0506-00
L44A	*108-0182-00			0.3 μ H	
L45A	*108-0170-01			0.5 μ H	
L84	276-0528-00			Core, ferramic suppressor	
L94	276-0528-00			Core, ferramic suppressor	
L95	276-0507-00			Core, ferramic suppressor	
L123	*108-0443-00			25 μ H	
L143A	*114-0170-00			0.15-0.25 μ H, Var	Core 276-0506-00
L144A	*108-0182-00			0.3 μ H	
L145A	*108-0170-01			0.5 μ H	
L199	276-0507-00			Core, ferramic suppressor	
L201	276-0528-00			Core, ferramic suppressor	
L202	276-0528-00			Core, ferramic suppressor	
L203	276-0528-00			Core, ferramic suppressor	
L204	276-0528-00			Core, ferramic suppressor	
L206	276-0528-00			Core, ferramic suppressor	
L209	276-0528-00			Core, ferramic suppressor	
LR287	*108-0329-00			2.5 μ H (wound on a 75 Ω resistor)	
Transistors					
Q23	*151-1011-00			Silicon	Dual, FET, Tek Spec
Q33	*153-0552-00			Silicon	Matched assembly
Q34					
Q43	151-0225-00	20000	43319	Silicon	2N3563
Q43 ¹⁴	*153-0583-00	43320		Silicon	2N3563 (matched pair)

¹⁴Furnished as a matched pair with Q143.

VERTICAL PREAMP Circuit Board Assembly (cont)

Ckt. No.	Tektronix Part No.	Serial/Model No. Eff	Disc	Description
Transistors (cont)				
Q54	151-0221-00			Silicon 2N4258
Q63	151-0220-00			Silicon 2N4122
Q84	151-0221-00			Silicon 2N4258
Q94	151-0221-00			Silicon 2N4258
Q123	*151-1011-00			Silicon Dual, FET, Tek Spec
Q133 } Q134 }	*153-0552-00			Silicon Matched assembly
Q143	151-0225-00	20000	43319	Silicon 2N3563
Q143 ¹⁵	*153-0583-00	43320		Silicon 2N3563 (matched pair)
Q154	151-0221-00			Silicon 2N4258
Q184	151-0221-00			Silicon 2N4258
Q194	151-0221-00			Silicon 2N4258
Q215	151-0223-00	20000	30719	Silicon 2N4275
Q215	*151-0190-01	30720		Silicon Tek Spec
Q225	151-0223-00	20000	30719	Silicon 2N4275
Q225	*151-0190-01	30720		Silicon Tek Spec
Q234	151-0223-00	20000	37999	Silicon 2N4275
Q234	151-0190-01	38000		Silicon Tek Spec
Q244	151-0223-00			Silicon 2N4275
Q253	151-0220-00			Silicon 2N4122
Q284	*151-0160-00			Silicon Selected from 2N3137
Q294	*151-0160-00			Silicon Selected from 2N3137

Resistors

Resistors are fixed, composition, $\pm 10\%$ unless otherwise indicated.

R16	315-0112-00			1.1 k Ω	1/4 W		5%
R17	322-0630-00			980 k Ω	1/4 W	Prec	1%
R18	316-0105-00			1 M Ω	1/4 W		
R19	315-0182-00			1.8 k Ω	1/4 W		5%
R20	321-0318-00			20 k Ω	1/8 W	Prec	1%
R21	315-0101-00			100 Ω	1/4 W		5%
R23	321-0163-00			487 Ω	1/8 W	Prec	1%
R24	321-0237-00			2.87 k Ω	1/8 W	Prec	1%
R25	321-0302-00			13.7 k Ω	1/8 W	Prec	1%
R26	321-0302-00			13.7 k Ω	1/8 W	Prec	1%
R31	315-0394-00	20000	23689	390 k Ω	1/4 W		5%
R31	315-0274-00	23690		270 k Ω	1/4 W		5%
R32	315-0102-00			1 k Ω	1/4 W		5%
R33	321-0165-00			511 Ω	1/8 W	Prec	1%
R34	316-0105-00			1 M Ω	1/4 W		
R36	321-0339-00			33.2 k Ω	1/8 W	Prec	1%
R37	315-0274-00			270 k Ω	1/4 W		5%
R38	321-0210-00			1.5 k Ω	1/8 W	Prec	1%
R39	316-0470-00			47 Ω	1/4 W		
R41	321-0281-00			8.25 k Ω	1/8 W	Prec	1%

¹⁵Furnished as a matched pair with Q43.

VERTICAL PREAMP Circuit Board Assembly (cont)

Ckt. No.	Tektronix Part No.	Serial/Model No. Eff	Disc	Description		
Resistors (cont)						
R43A	321-0078-00			63.4 Ω	$\frac{1}{8}$ W	Prec 1%
R43C	311-0442-00			250 Ω , Var		
R43E	315-0302-00	X38690		3 k Ω	$\frac{1}{4}$ W	5%
R44A	321-0124-00			191 Ω	$\frac{1}{8}$ W	Prec 1%
R44B	315-0133-00	X38690		13 k Ω	$\frac{1}{4}$ W	5%
R44C	311-0462-00			1 k Ω , Var		
R45A	321-0151-00			365 Ω	$\frac{1}{8}$ W	Prec 1%
R46	321-0136-00			255 Ω	$\frac{1}{8}$ W	Prec 1%
R47	321-0237-00			2.87 k Ω	$\frac{1}{8}$ W	Prec 1%
R48	321-0212-00			1.58 k Ω	$\frac{1}{8}$ W	Prec 1%
R49	311-0462-00			1 k Ω , Var		
R50	321-0136-00			255 Ω	$\frac{1}{8}$ W	Prec 1%
R51	316-0680-00			68 Ω	$\frac{1}{4}$ W	
R52	321-0216-00			1.74 k Ω	$\frac{1}{8}$ W	Prec 1%
R54	316-0680-00			68 Ω	$\frac{1}{4}$ W	
R55	311-0480-00			500 Ω , Var		
R56	315-0752-00			7.5 k Ω	$\frac{1}{4}$ W	5%
R58	301-0112-00			1.1 k Ω	$\frac{1}{2}$ W	5%
R59	315-0331-00			330 Ω	$\frac{1}{4}$ W	5%
R60	311-0465-00			100 k Ω , Var		
R61	315-0153-00			15 k Ω	$\frac{1}{4}$ W	5%
R63	301-0122-00			1.2 k Ω	$\frac{1}{2}$ W	5%
R64	315-0331-00			330 Ω	$\frac{1}{4}$ W	5%
R66	321-0083-00			71.5 Ω	$\frac{1}{8}$ W	Prec 1%
R83	321-0207-00			1.4 k Ω	$\frac{1}{8}$ W	Prec 1%
R84	315-0331-00			330 Ω	$\frac{1}{4}$ W	5%
R92	321-0121-00			178 Ω	$\frac{1}{8}$ W	Prec 1%
R93	321-0207-00			1.4 k Ω	$\frac{1}{8}$ W	Prec 1%
R94	315-0331-00			330 Ω	$\frac{1}{4}$ W	5%
R96	315-0100-00			10 Ω	$\frac{1}{4}$ W	5%
R97	315-0100-00			10 Ω	$\frac{1}{4}$ W	5%
R116	315-0112-00			1.1 k Ω	$\frac{1}{4}$ W	5%
R117	322-0630-00			980 k Ω	$\frac{1}{4}$ W	Prec 1%
R118	316-0105-00			1 M Ω	$\frac{1}{4}$ W	
R119	315-0182-00			1.8 k Ω	$\frac{1}{4}$ W	5%
R120	321-0318-00			20 k Ω	$\frac{1}{8}$ W	Prec 1%
R121	315-0101-00			100 Ω	$\frac{1}{4}$ W	5%
R123	321-0163-00			487 Ω	$\frac{1}{8}$ W	Prec 1%
R124	321-0237-00			2.87 k Ω	$\frac{1}{8}$ W	Prec 1%
R125	321-0302-00			13.7 k Ω	$\frac{1}{8}$ W	Prec 1%
R126	321-0302-00			13.7 k Ω	$\frac{1}{8}$ W	Prec 1%
R131	315-0394-00	20000	23689	390 k Ω	$\frac{1}{4}$ W	5%
R131	315-0274-00	23690		270 k Ω	$\frac{1}{4}$ W	5%
R132	315-0102-00			1 k Ω	$\frac{1}{4}$ W	5%
R133	321-0165-00			511 Ω	$\frac{1}{8}$ W	Prec 1%
R134	316-0105-00			1 M Ω	$\frac{1}{4}$ W	
R136	321-0339-00			33.2 k Ω	$\frac{1}{8}$ W	Prec 1%

VERTICAL PREAMP Circuit Board Assembly (cont)

Ckt. No.	Tektronix Part No.	Serial/Model No. Eff	Disc	Description		
Resistors (cont)						
R137	315-0274-00		270 k Ω	1/4 W		5%
R138	321-0210-00		1.5 k Ω	1/8 W	Prec	1%
R139	316-0470-00		47 Ω	1/4 W		
R141	321-0281-00		8.25 k Ω	1/8 W	Prec	1%
R143A	321-0078-00		63.4 Ω	1/8 W	Prec	1%
R143C	311-0442-00		250 Ω , Var			
R143E	315-0302-00	X38690	3 k Ω	1/4 W		5%
R144A	321-0124-00		191 Ω	1/8 W	Prec	1%
R144B	315-0133-00	X38690	13 k Ω	1/4 W		5%
R144C	311-0462-00		1 k Ω , Var			
R145A	321-0151-00		365 Ω	1/8 W	Prec	1%
R146	321-0136-00		255 Ω	1/8 W	Prec	1%
R147	321-0237-00		2.87 k Ω	1/8 W	Prec	1%
R148	321-0212-00		1.58 k Ω	1/8 W	Prec	1%
R149	311-0462-00		1 k Ω , Var			
R150	321-0136-00		255 Ω	1/8 W	Prec	1%
R151	316-0680-00		68 Ω	1/4 W		
R152	321-0216-00		1.74 k Ω	1/8 W	Prec	1%
R154	316-0680-00		68 Ω	1/4 W		
R155	311-0480-00		500 Ω , Var			
R156	315-0752-00		7.5 k Ω	1/4 W		5%
R158	301-0122-00		1.2 k Ω	1/2 W		5%
R159	315-0331-00		330 Ω	1/4 W		5%
R183	321-0207-00		1.4 k Ω	1/8 W	Prec	1%
R184	315-0331-00		330 Ω	1/4 W		5%
R192	321-0121-00		178 Ω	1/8 W	Prec	1%
R193	321-0207-00		1.4 k Ω	1/8 W	Prec	1%
R194	315-0331-00		330 Ω	1/4 W		5%
R195	315-0473-00		47 k Ω	(nominal value)	Selected	
R197	315-0100-00		10 Ω	1/4 W		5%
R199	315-0100-00		10 Ω	1/4 W		5%
R211	315-0200-00		20 Ω	1/4 W		5%
R212	321-0175-00		649 Ω	1/8 W	Prec	1%
R213	321-0123-00		187 Ω	1/8 W	Prec	1%
R214	321-0193-00		1 k Ω	1/8 W	Prec	1%
R215	321-0229-00		2.37 k Ω	1/8 W	Prec	1%
R216	315-0332-00		3.3 k Ω	1/4 W		5%
R217	321-0113-00		147 Ω	1/8 W	Prec	1%
R218	321-0125-00		196 Ω	1/8 W	Prec	1%
R221	315-0200-00		20 Ω	1/4 W		5%
R222	321-0175-00		649 Ω	1/8 W	Prec	1%
R223	321-0123-00		187 Ω	1/8 W	Prec	1%
R224	321-0193-00		1 k Ω	1/8 W	Prec	1%
R225	321-0229-00		2.37 k Ω	1/8 W	Prec	1%
R227	321-0113-00		147 Ω	1/8 W	Prec	1%
R228	321-0125-00		196 Ω	1/8 W	Prec	1%
R232	315-0153-00		15 k Ω	1/4 W		5%

VERTICAL PREAMP Circuit Board Assembly (cont)

Ckt. No.	Tektronix Part No.	Serial/Model No. Eff	No. Disc	Description		
Resistors (cont)						
R233	315-0332-00			3.3 k Ω	1/4 W	5%
R234	321-0081-00			68.1 Ω	1/8 W	Prec 1%
R235	315-0102-00			1 k Ω	1/4 W	5%
R241	315-0753-00	20000	37999	75 k Ω	1/4 W	5%
R241	315-0473-00	38000		47 k Ω	1/4 W	5%
R244	315-0392-00			3.9 k Ω	1/4 W	5%
R245	315-0222-00			2.2 k Ω	1/4 W	5%
R253	315-0102-00			1 k Ω	1/4 W	5%
R260	321-0179-00			715 Ω	1/8 W	Prec 1%
R261	315-0363-00			36 k Ω	1/4 W	5%
R262	321-0235-00			2.74 k Ω	1/8 W	Prec 1%
R264	321-0267-00			5.9 k Ω	1/8 W	Prec 1%
R265	321-0205-00			1.33 k Ω	1/8 W	Prec 1%
R267	321-0164-00			499 Ω	1/8 W	Prec 1%
R268	321-0117-00			162 Ω	1/8 W	Prec 1%
R269	321-0117-00			162 Ω	1/8 W	Prec 1%
R270	321-0179-00			715 Ω	1/8 W	Prec 1%
R277	321-0164-00			499 Ω	1/8 W	Prec 1%
R278	321-0117-00			162 Ω	1/8 W	Prec 1%
R279	321-0117-00			162 Ω	1/8 W	Prec 1%
R284	321-0161-00			464 Ω	1/8 W	Prec 1%
R285	311-0480-00			500 Ω , Var		
R286	321-0197-00			1.1 k Ω	1/8 W	Prec 1%
R288	321-0087-00			78.7 Ω	1/8 W	Prec 1%
R289	315-0331-00			330 Ω	1/4 W	5%
R291	315-0221-00			220 Ω	1/4 W	5%
R292	323-0099-00			105 Ω	1/2 W	Prec 1%
R294	315-0752-00			7.5 k Ω	1/4 W	5%
R295	315-0621-00			620 Ω	1/4 W	5%
R298	321-0087-00			78.7 Ω	1/8 W	Prec 1%
R299	315-0120-00			12 Ω	1/4 W	5%

Switch

Wired or Unwired

SW195	260-0447-00	Slide	INVERT
-------	-------------	-------	--------

Transformers

T195	276-0576-00	Core, toroid ferrite
T241	*120-0384-00	Toroid, 10 turns-5 turns

PARTS LIST ABBREVIATIONS

BHB	binding head brass	int	internal
BHS	binding head steel	lg	length or long
cap.	capacitor	met.	metal
cer	ceramic	mtg hdw	mounting hardware
comp	composition	OD	outside diameter
conn	connector	OHB	oval head brass
CRT	cathode-ray tube	OHS	oval head steel
csk	countersunk	P/O	part of
DE	double end	PHB	pan head brass
dia	diameter	PHS	pan head steel
div	division	plstc	plastic
elect.	electrolytic	PMC	paper, metal cased
EMC	electrolytic, metal cased	poly	polystyrene
EMT	electrolytic, metal tubular	prec	precision
ext	external	PT	paper, tubular
F & I	focus and intensity	PTM	paper or plastic, tubular, molded
FHB	flat head brass	RHB	round head brass
FHS	flat head steel	RHS	round head steel
Fil HB	fillister head brass	SE	single end
Fil HS	fillister head steel	SN or S/N	serial number
h	height or high	S or SW	switch
hex.	hexagonal	TC	temperature compensated
HHB	hex head brass	THB	truss head brass
HHS	hex head steel	thk	thick
HSB	hex socket brass	THS	truss head steel
HSS	hex socket steel	tub.	tubular
ID	inside diameter	var	variable
inc	incandescent	w	wide or width
		WW	wire-wound

PARTS ORDERING INFORMATION

Replacement parts are available from or through your local Tektronix, Inc. Field Office or representative.

Changes to Tektronix instruments are sometimes made to accommodate improved components as they become available, and to give you the benefit of the latest circuit improvements developed in our engineering department. It is therefore important, when ordering parts, to include the following information in your order: Part number, instrument type or number, serial or model number, and modification number if applicable.





If a part you have ordered has been replaced with a new or improved part, your local Tektronix, Inc. Field Office or representative will contact you concerning any change in part number.

SPECIAL NOTES AND SYMBOLS

- | | |
|-----------------|---|
| ×000 | Part first added at this serial number |
| 00× | Part removed after this serial number |
| *000-0000-00 | Asterisk preceding Tektronix Part Number indicates manufactured by or for Tektronix, Inc., or reworked or checked components. |
| Use 000-0000-00 | Part number indicated is direct replacement. |

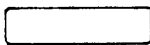
SECTION 8 DIAGRAMS and MECHANICAL PARTS ILLUSTRATIONS

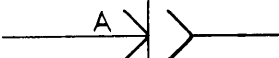
The following symbols are used on the diagrams:

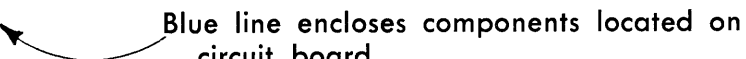
-  Screwdriver adjustment
-  Front-, side- or rear-panel control or connector
-  Clockwise control rotation in direction of arrow
-  Refer to indicated diagram
-  Connection to circuit board made with pin connector at indicated pin
-  Connection soldered to circuit board
-  Blue line encloses components located on circuit board

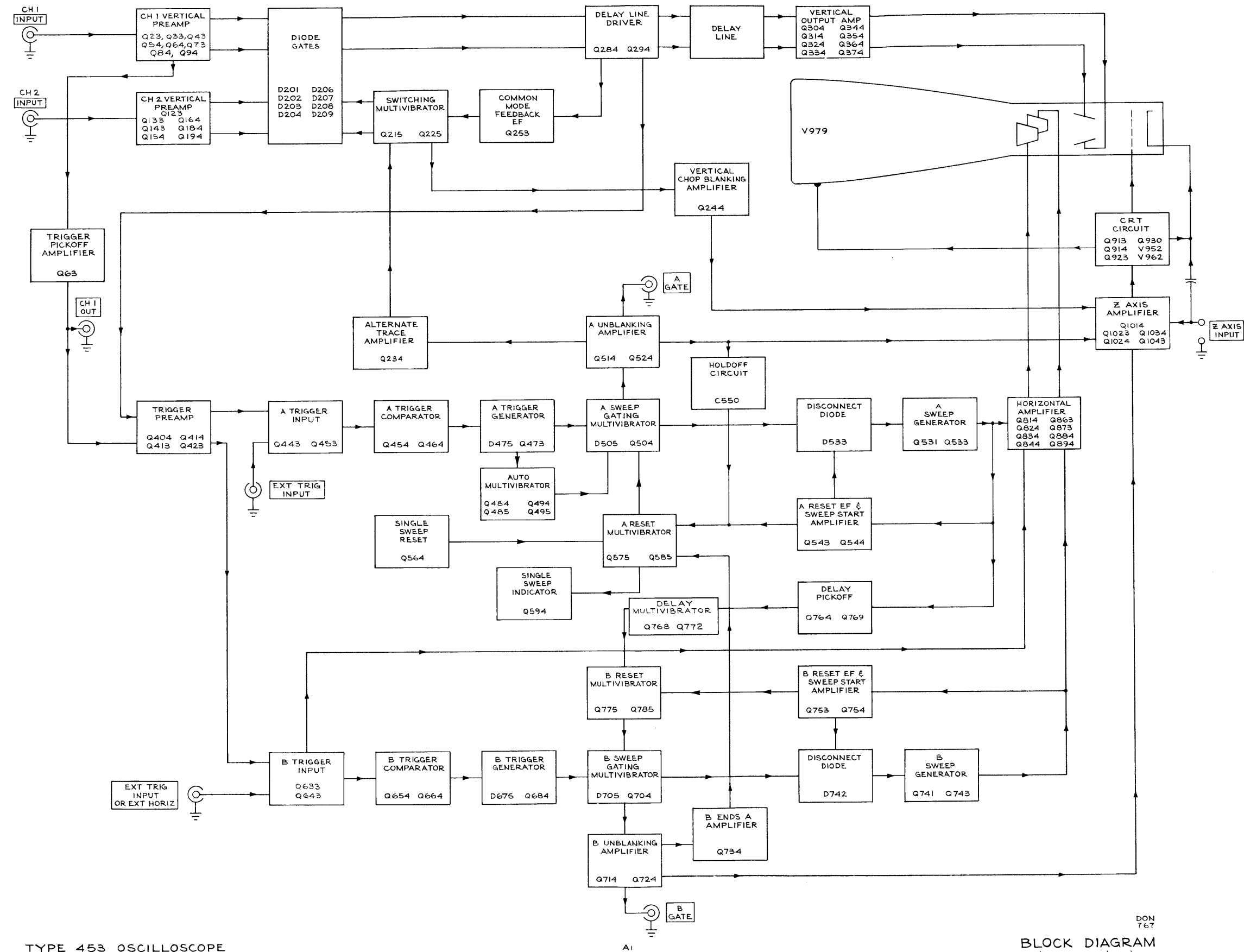

TYPE 453 OSCILLOSCOPE

A1

DON
TGT
BLOCK DIAGRAM
(S/N 20,000 & UP)

VOLTAGE AND WAVEFORM TEST CONDITIONS

Typical voltage measurements and waveform photographs were obtained under the following conditions unless noted otherwise on the individual diagrams:

Test Oscilloscope (with 10X Probe)

Frequency response	DC to 20 MHz
Deflection factor (with probe)	50 millivolts to 10 volts/division
Input impedance	10 Megohms, 7.5 picofarads
Probe ground	Type 453 chassis ground
Trigger Source	External from A GATE connector to indicate true time relationship between signals

Recommended type (as used for waveforms on diagrams)
Tektronix Type 545B with Type 1A1 plug-in unit

Voltmeter

Type	Non-loading AC (RMS)—DC VTVM
Sensitivity	20,000 ohms/volt
Range	0 to 300 volts
Reference voltage	Type 453 chassis ground
Recommended type (as used for voltages on diagrams)	General Radio Type 1806-A Electronic Voltmeter

Type 453 Conditions

Line voltage	115 volts
Signal applied	Calibrator output signal connected to Channel 1 and 2 INPUT connectors for waveforms only
Connectors	No connections (except as above)
Trace position	Centered
Control settings	As follows except as noted otherwise on individual diagrams:

CRT Controls

INTENSITY	Midrange
FOCUS	Adjust for focused display
SCALE ILLUM	As desired

Vertical Controls (both channels if applicable)

VOLTS/DIV	20 mV
VARIABLE	CAL
POSITION	Midrange
Input Coupling	DC
MODE	CH 1
TRIGGER	NORM
INVERT	Pushed in

Triggering Controls (both A and B if applicable)

LEVEL	0
SLOPE	+
COUPLING	AC
SOURCE	INT

Sweep Controls

DELAY-TIME MULTIPLIER	0.20
A TIME/DIV	1 ms
B TIME/DIV	1 ms
A VARIABLE	CAL
A SWEEP MODE	AUTO TRIG
B SWEEP MODE	TRIGGERABLE AFTER DELAY TIME
HORIZ DISPLAY	A
MAG	OFF
A SWEEP LENGTH	FULL
POSITION	Midrange
FINE	Midrange
POWER	ON

Side-Panel Controls

B TIME/DIV VARIABLE	CAL
CALIBRATOR	1 V

All voltages given on the diagrams are in volts. Waveforms shown are actual waveform photographs taken with a Tektronix Oscilloscope Camera System and Projected Graticule. Voltages and waveforms on the diagrams (shown in blue) are not absolute and may vary between instruments because of differing component tolerances, internal calibration or front-panel control settings.

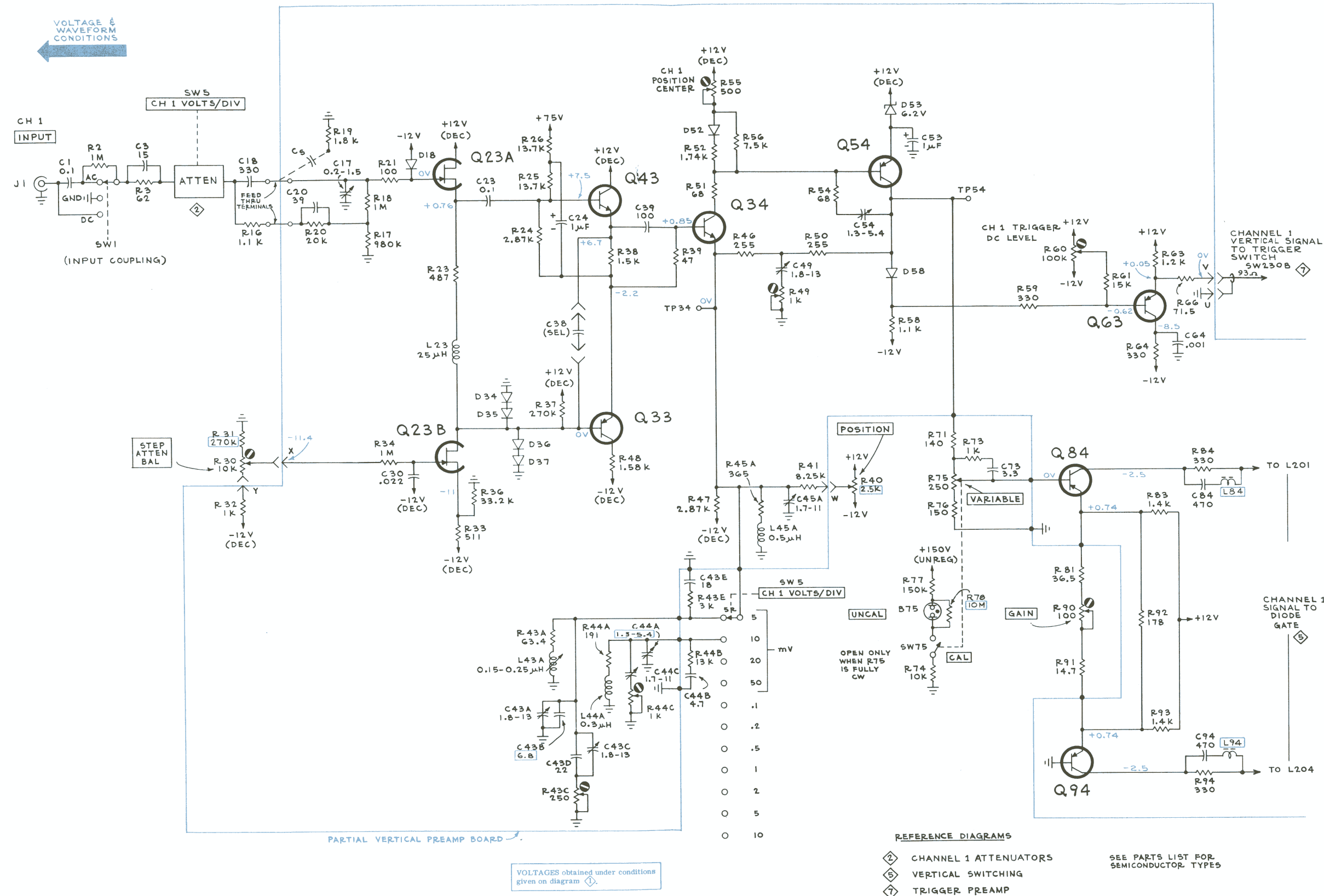

TYPE 453 OSCILLOSCOPE

CHANNEL 1 VERTICAL PREAMP (S/N 20,000 & UP)

SEE PARTS LIST FOR EARLIER VALUES AND SERIAL NUMBER RANGES OF PARTS MARKED WITH BLUE OUTLINE.

SEE PARTS LIST FOR SEMICONDUCTOR TYPES

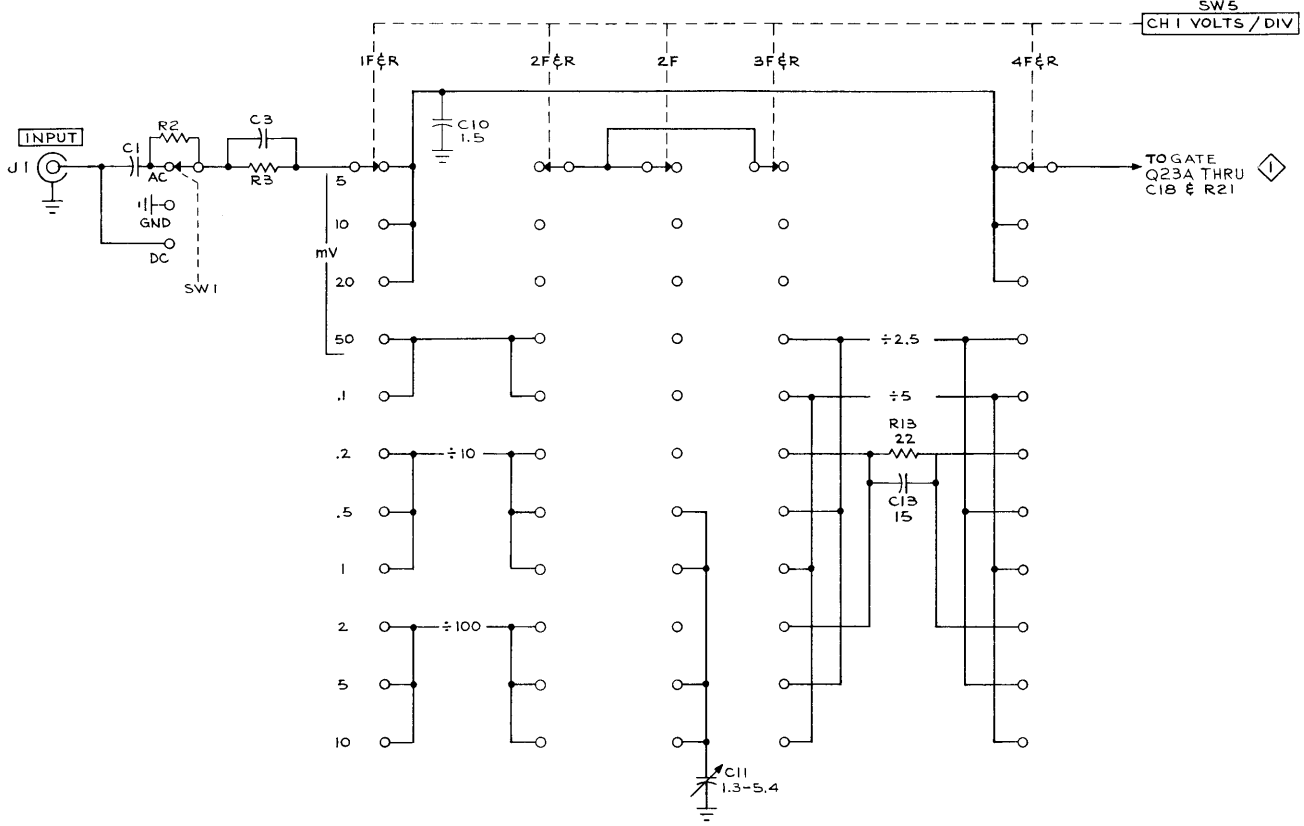

÷ 10

÷ 2.5

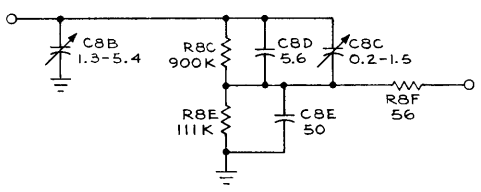

÷ 100

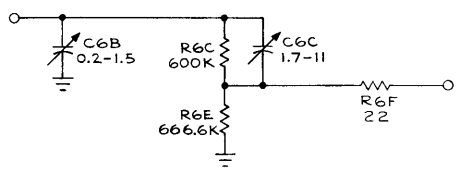

÷ 5

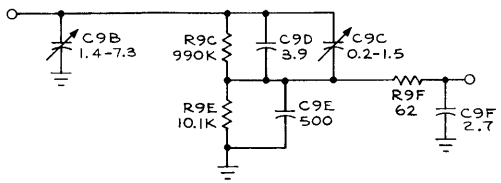

÷ 100

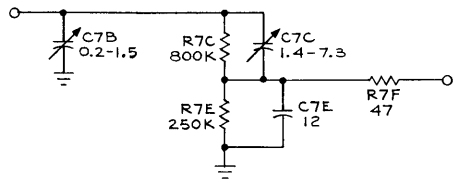

÷ 5

REFERENCE DIAGRAMS

① CHANNEL 1 VERTICAL PREAMP

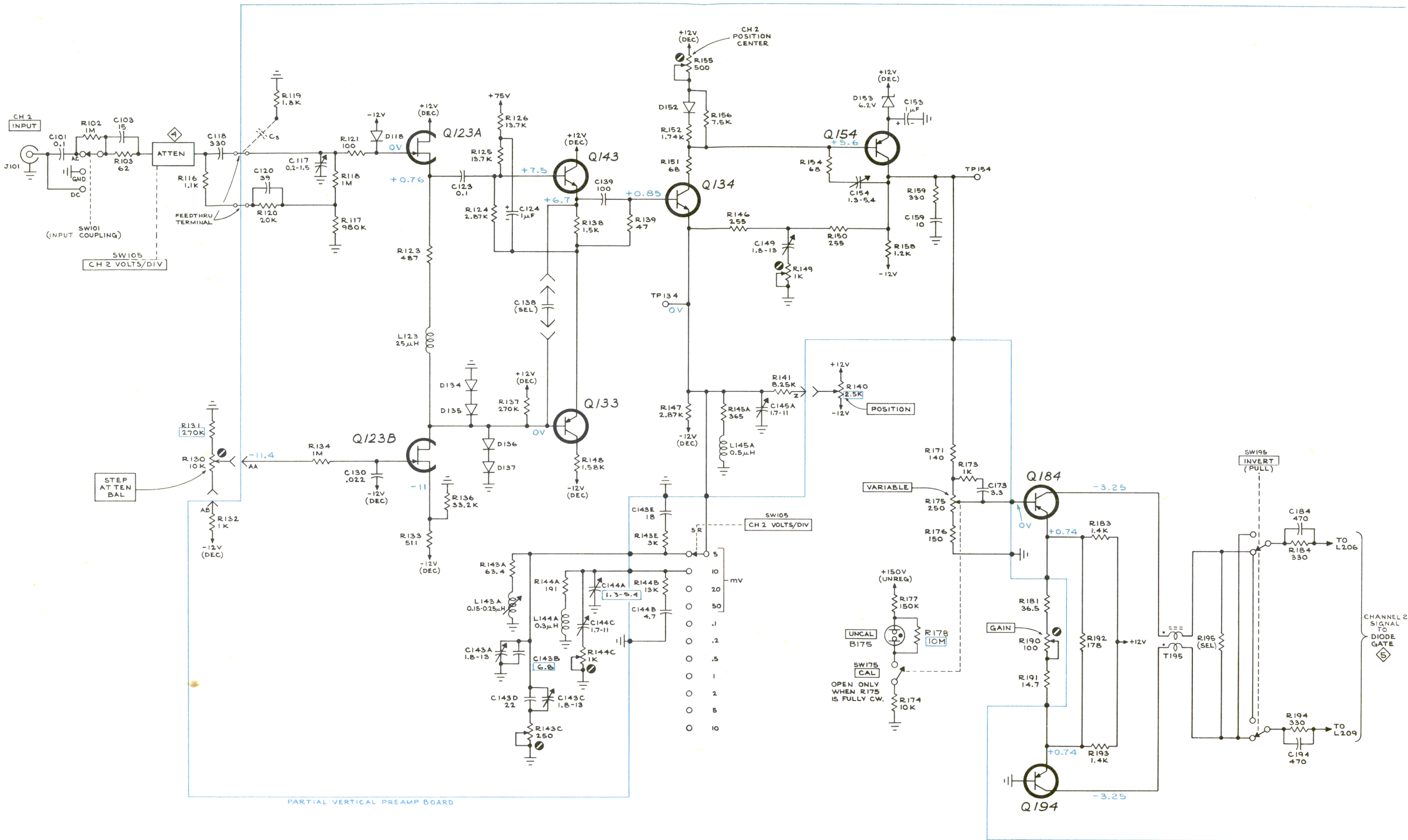

PARTIAL VERTICAL PREAMP BOARD

REFERENCE DIAGRAMS
 4 CHANNEL 2 ATTENUATORS
 5 VERTICAL SWITCHING

VOLTAGES obtained under conditions given on diagram.

SEE PARTS LIST FOR SEMICONDUCTOR TYPES.

SEE PARTS LIST FOR EARLIER VALUES AND SERIAL NUMBER RANGES OF PARTS MARKED WITH BLUE OUTLINE.

CMD 1070

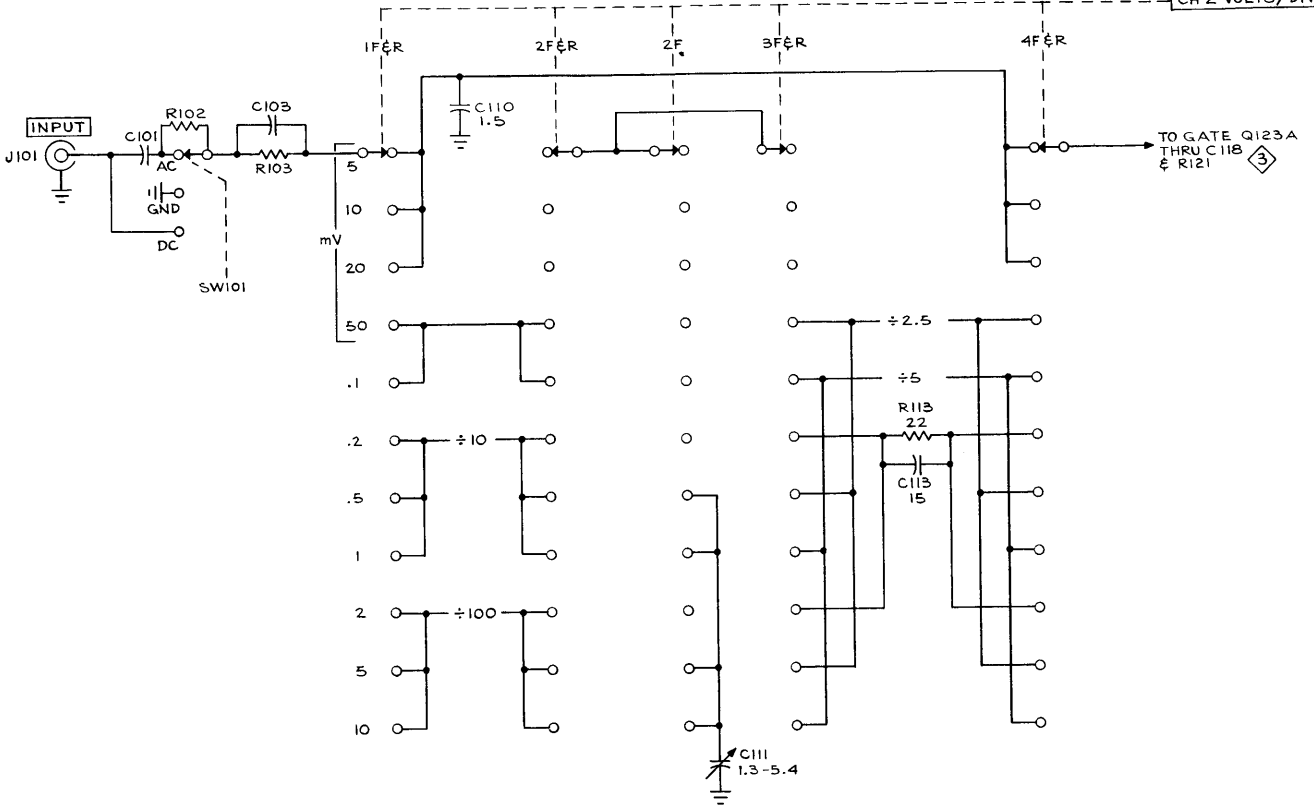

$\div 10$

$\div 2.5$

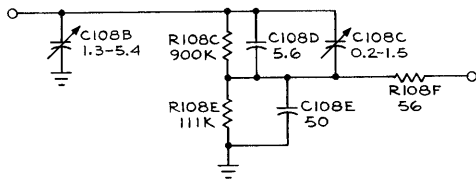

$\div 100$

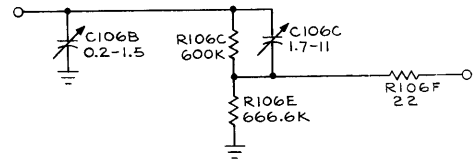

$\div 5$

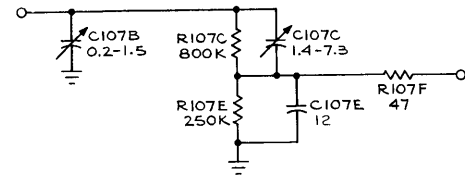
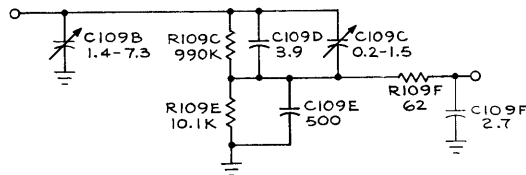

REFERENCE DIAGRAMS

③ CHANNEL 2 VERTICAL PREAMP

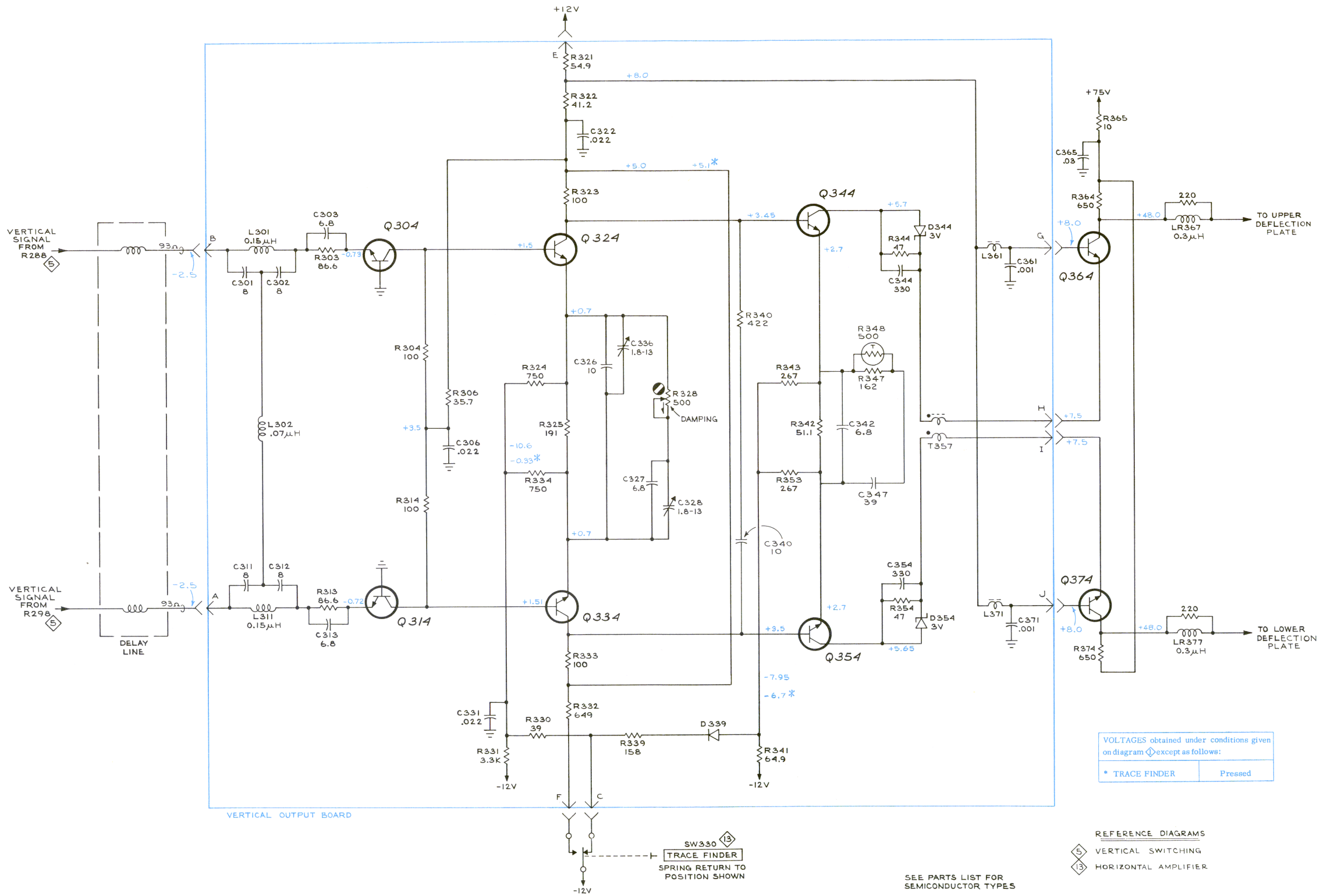

VOLTAGES obtained under conditions given on diagram \diamond except as follows:

* TRACE FINDER	Pressed
----------------	---------

REFERENCE DIAGRAMS

- \diamond VERTICAL SWITCHING
- \diamond HORIZONTAL AMPLIFIER

SEE PARTS LIST FOR SEMICONDUCTOR TYPES

T67
CMD

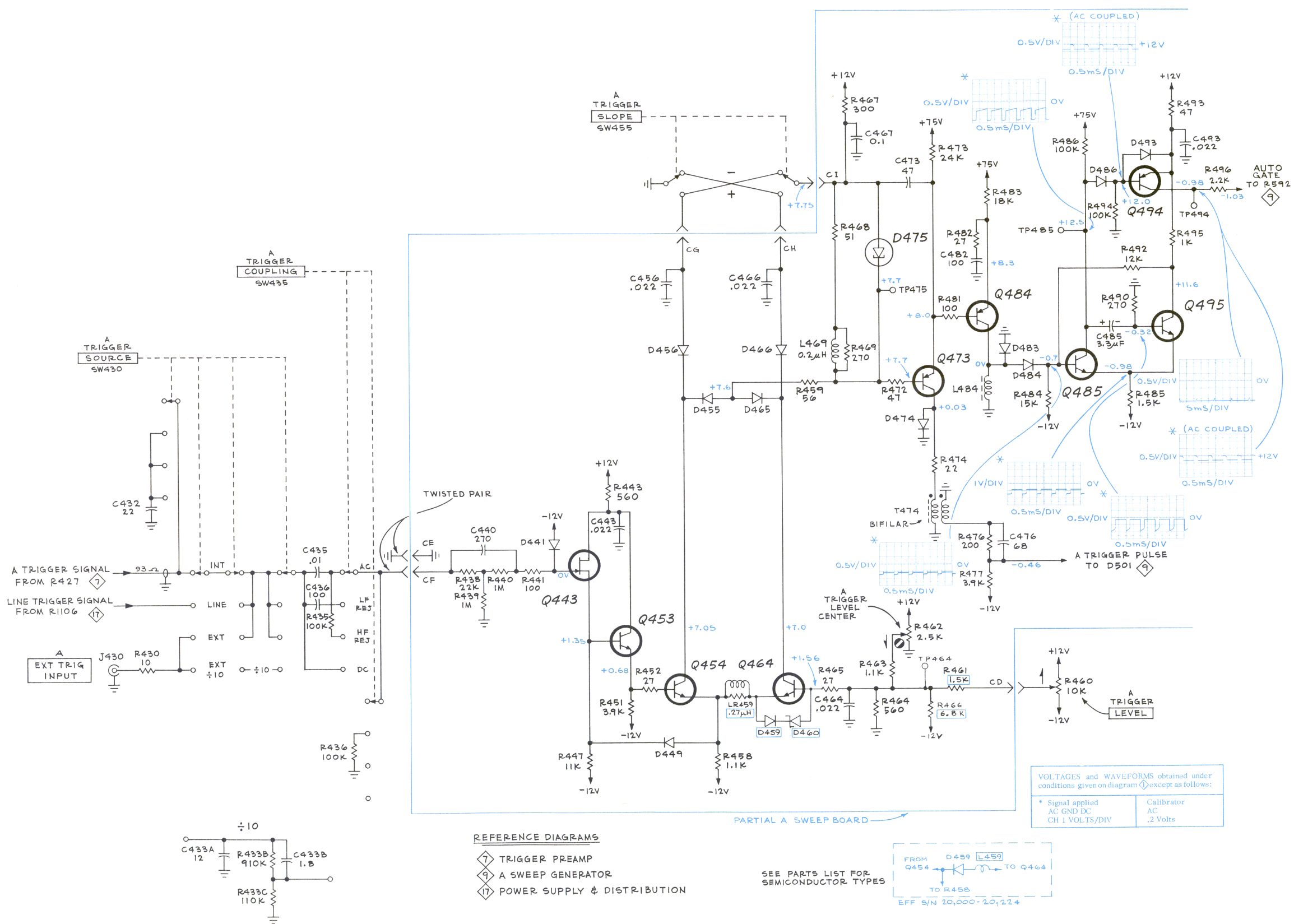

VOLTAGES and WAVEFORMS obtained under conditions given on diagram except as follows:

* Signal applied	Calibrator
AC GND DC	AC
CH 1 VOLTS/DIV	.2 Volts

- REFERENCE DIAGRAMS
- 7 TRIGGER PREAMP
 - 9 A SWEEP GENERATOR
 - 17 POWER SUPPLY & DISTRIBUTION

SEE PARTS LIST FOR SEMICONDUCTOR TYPES

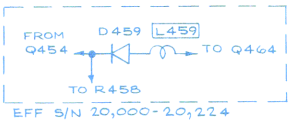

SEE PARTS LIST FOR EARLIER VALUES AND SERIAL NUMBER RANGES OF PARTS MARKED WITH BLUE OUTLINE.

A TRIGGER GENERATOR (S/N 20,000 & UP)

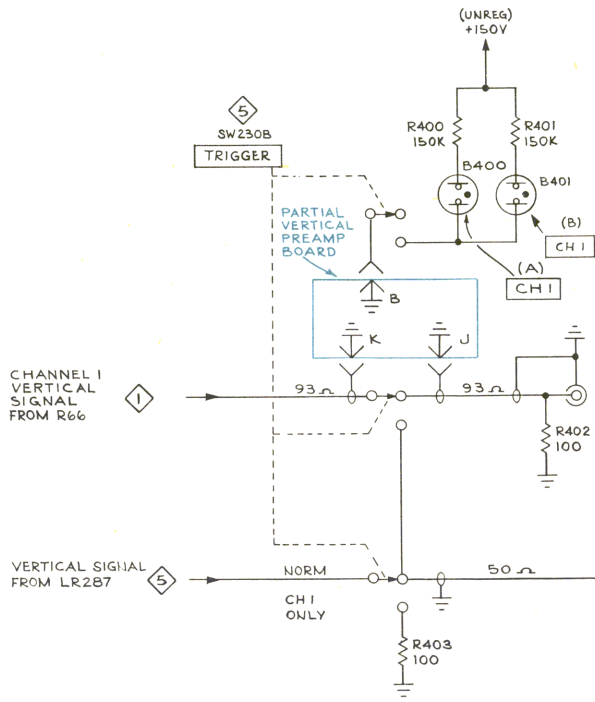

- REFERENCE DIAGRAMS
- ① CHANNEL 1 INPUT AMPLIFIER
 - ⑤ VERTICAL SWITCHING
 - ⑧ A TRIGGER GENERATOR
 - ⑩ B TRIGGER GENERATOR

SEE PARTS LIST FOR SEMICONDUCTOR TYPES.

VOLTAGES obtained under conditions given on diagram ①.

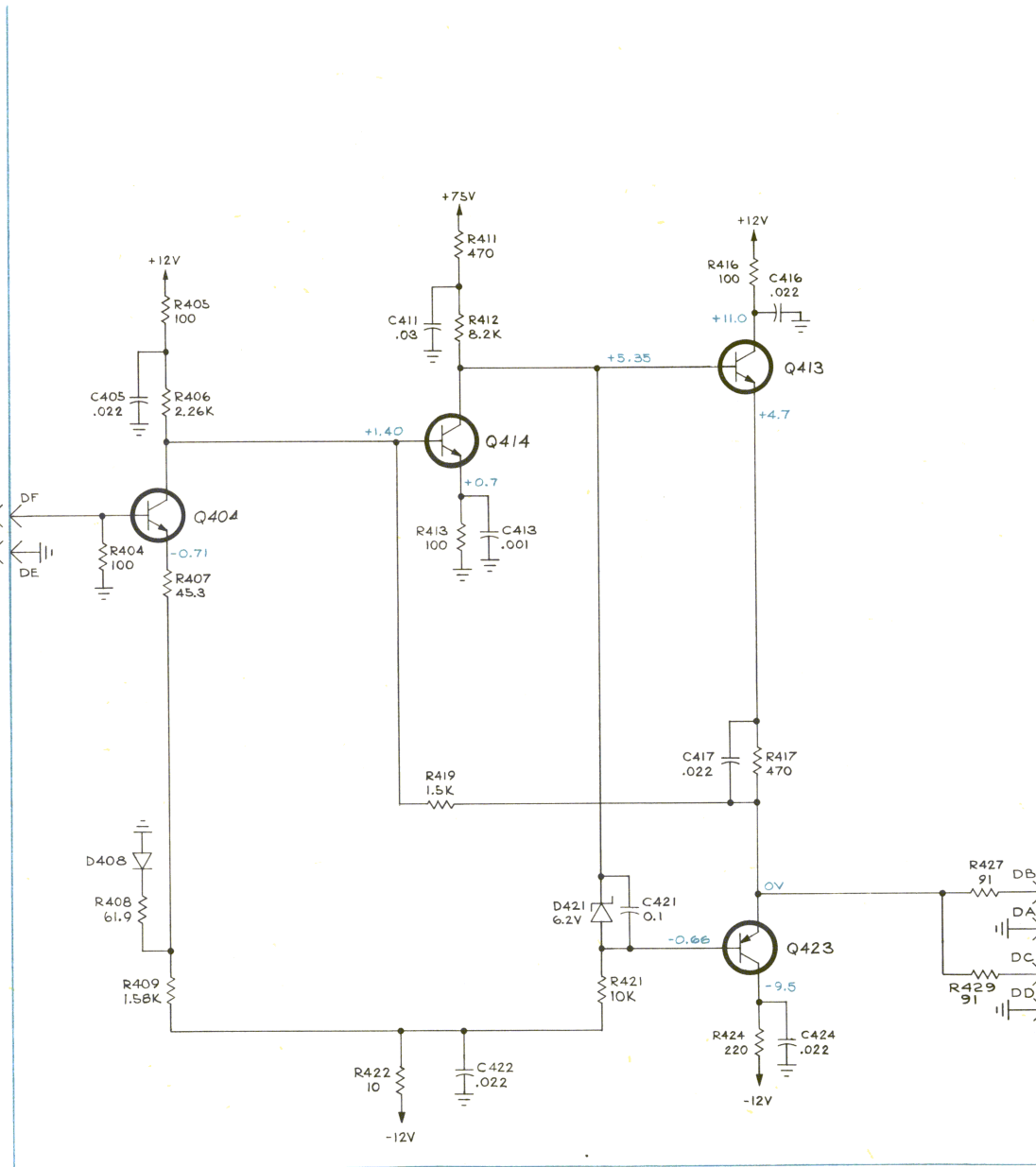

PARTIAL A SWEEP BOARD

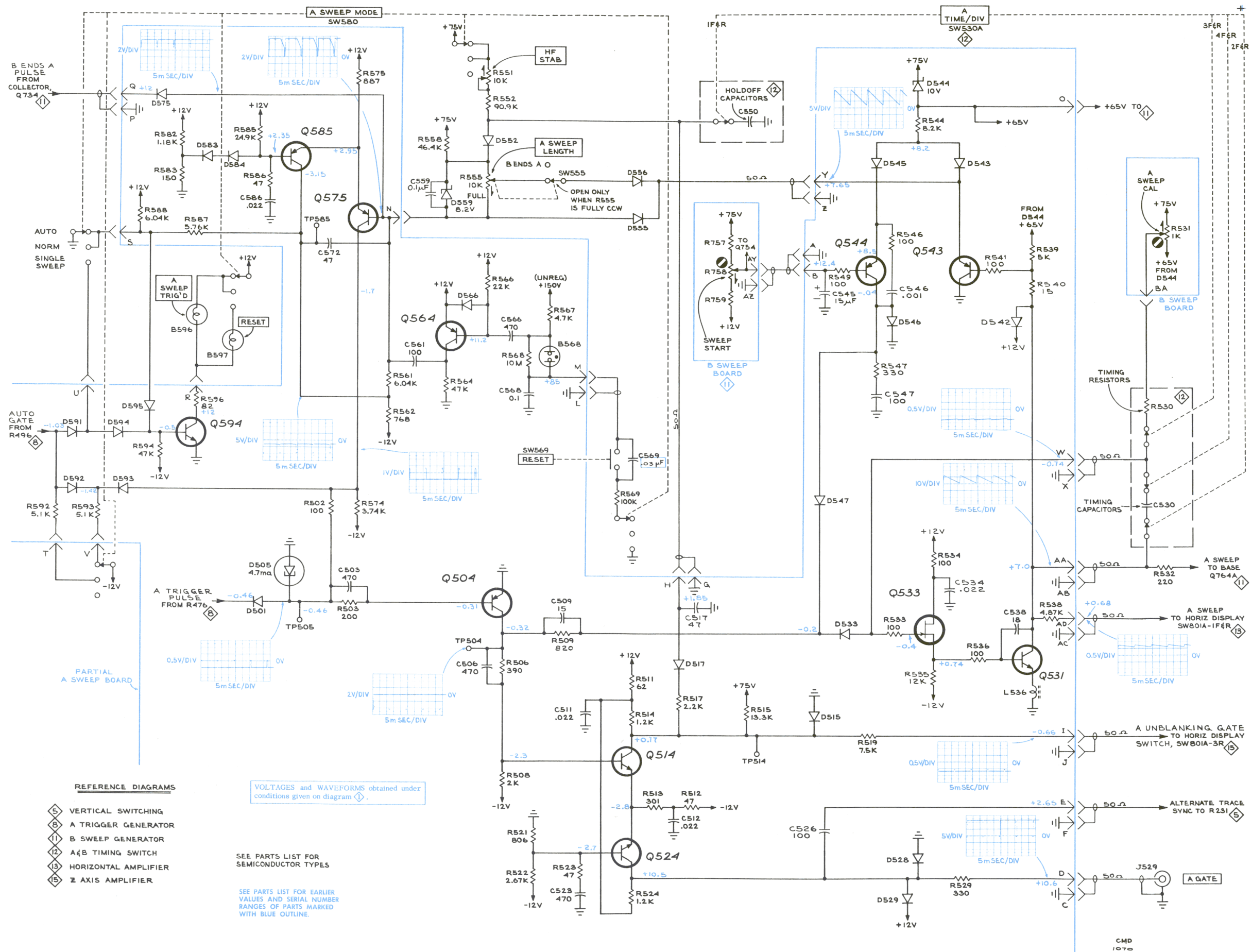

REFERENCE DIAGRAMS

- 5 VERTICAL SWITCHING
- 8 A TRIGGER GENERATOR
- 11 B SWEEP GENERATOR
- 12 A&B TIMING SWITCH
- 13 HORIZONTAL AMPLIFIER
- 15 Z AXIS AMPLIFIER

VOLTAGES and WAVEFORMS obtained under conditions given on diagram.

SEE PARTS LIST FOR SEMICONDUCTOR TYPES

SEE PARTS LIST FOR EARLIER VALUES AND SERIAL NUMBER RANGES OF PARTS MARKED WITH BLUE OUTLINE.

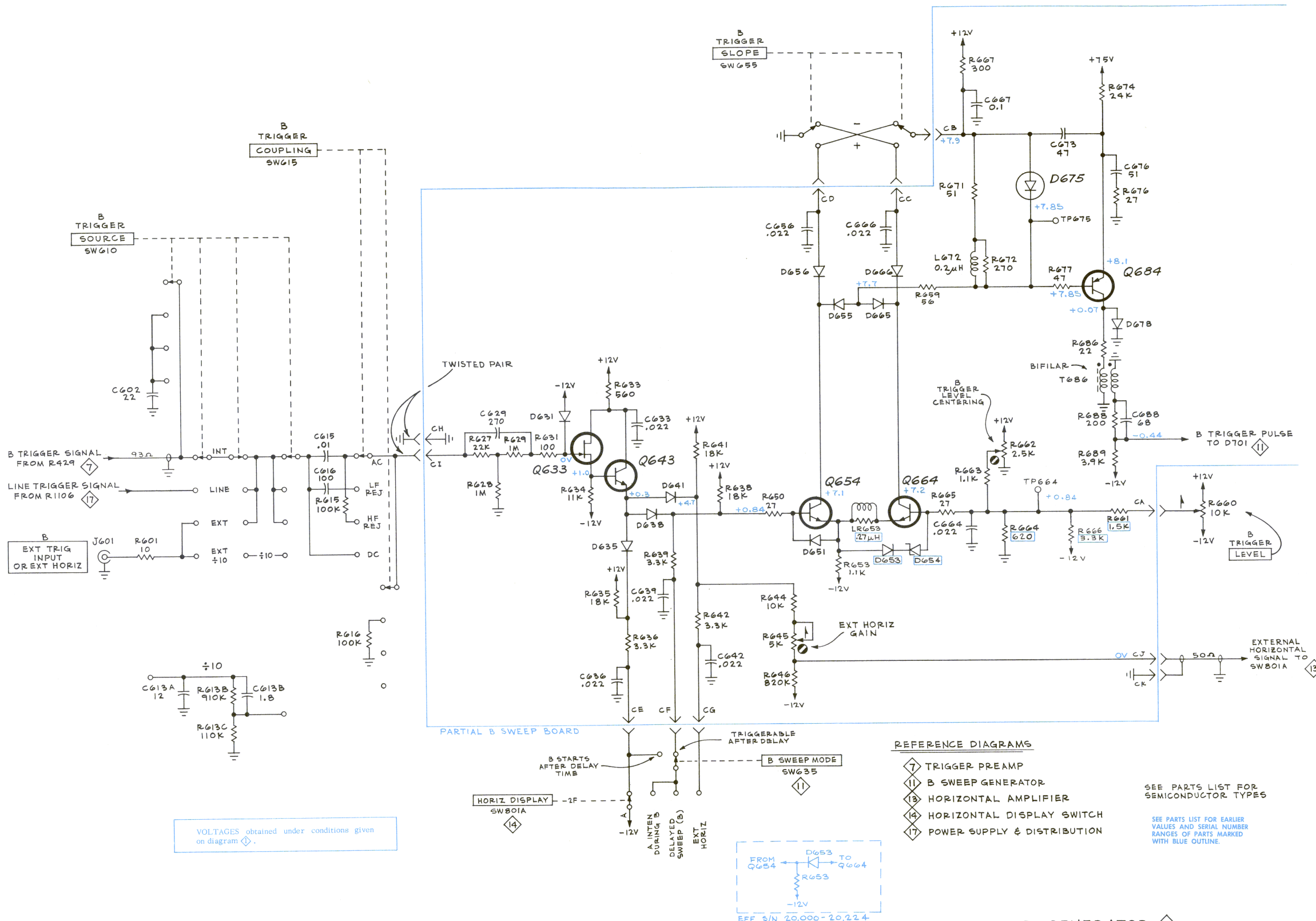

VOLTAGES obtained under conditions given on diagram \diamond .

- REFERENCE DIAGRAMS**
- $\diamond 7$ TRIGGER PREAMP
 - $\diamond 11$ B SWEEP GENERATOR
 - $\diamond 13$ HORIZONTAL AMPLIFIER
 - $\diamond 14$ HORIZONTAL DISPLAY SWITCH
 - $\diamond 17$ POWER SUPPLY & DISTRIBUTION

SEE PARTS LIST FOR SEMICONDUCTOR TYPES
SEE PARTS LIST FOR EARLIER VALUES AND SERIAL NUMBER RANGES OF PARTS MARKED WITH BLUE OUTLINE.

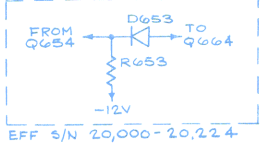

B TRIGGER GENERATOR $\diamond 10$
(S/N 20,000 & UP)

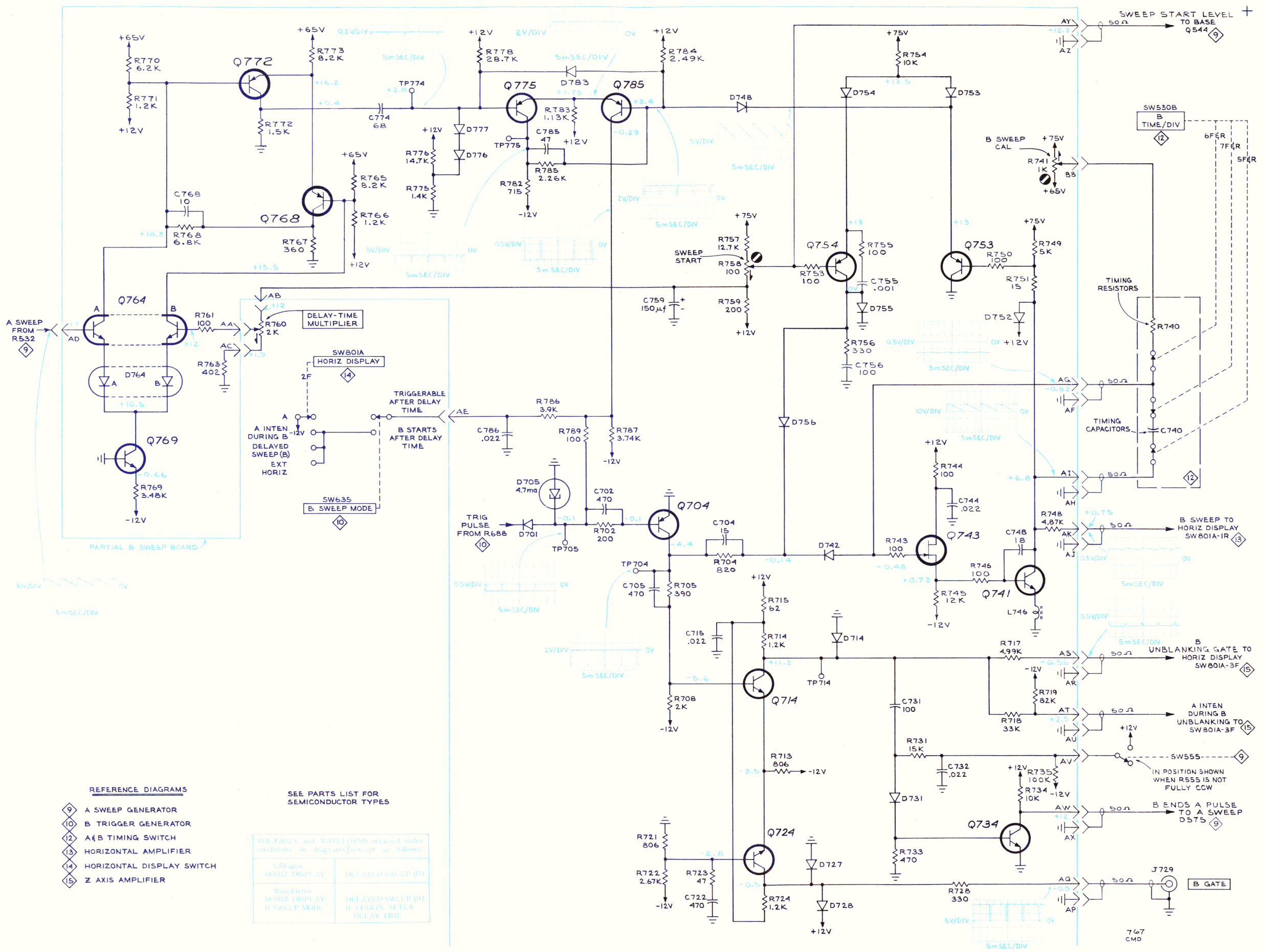

REFERENCE DIAGRAMS

- 9 A SWEEP GENERATOR
- 10 B TRIGGER GENERATOR
- 12 A & B TIMING SWITCH
- 13 HORIZONTAL AMPLIFIER
- 14 HORIZONTAL DISPLAY SWITCH
- 15 Z AXIS AMPLIFIER

SEE PARTS LIST FOR SEMICONDUCTOR TYPES

VOLTAGES and WAVEFORMS obtained under conditions on diagram except as follows:

Voltages HORIZ DISPLAY	DELAYED SWEEP (B)
Waveforms HORIZ DISPLAY B SWEEP MODE	DELAYED SWEEP (B) B STARTS AFTER DELAY TIME

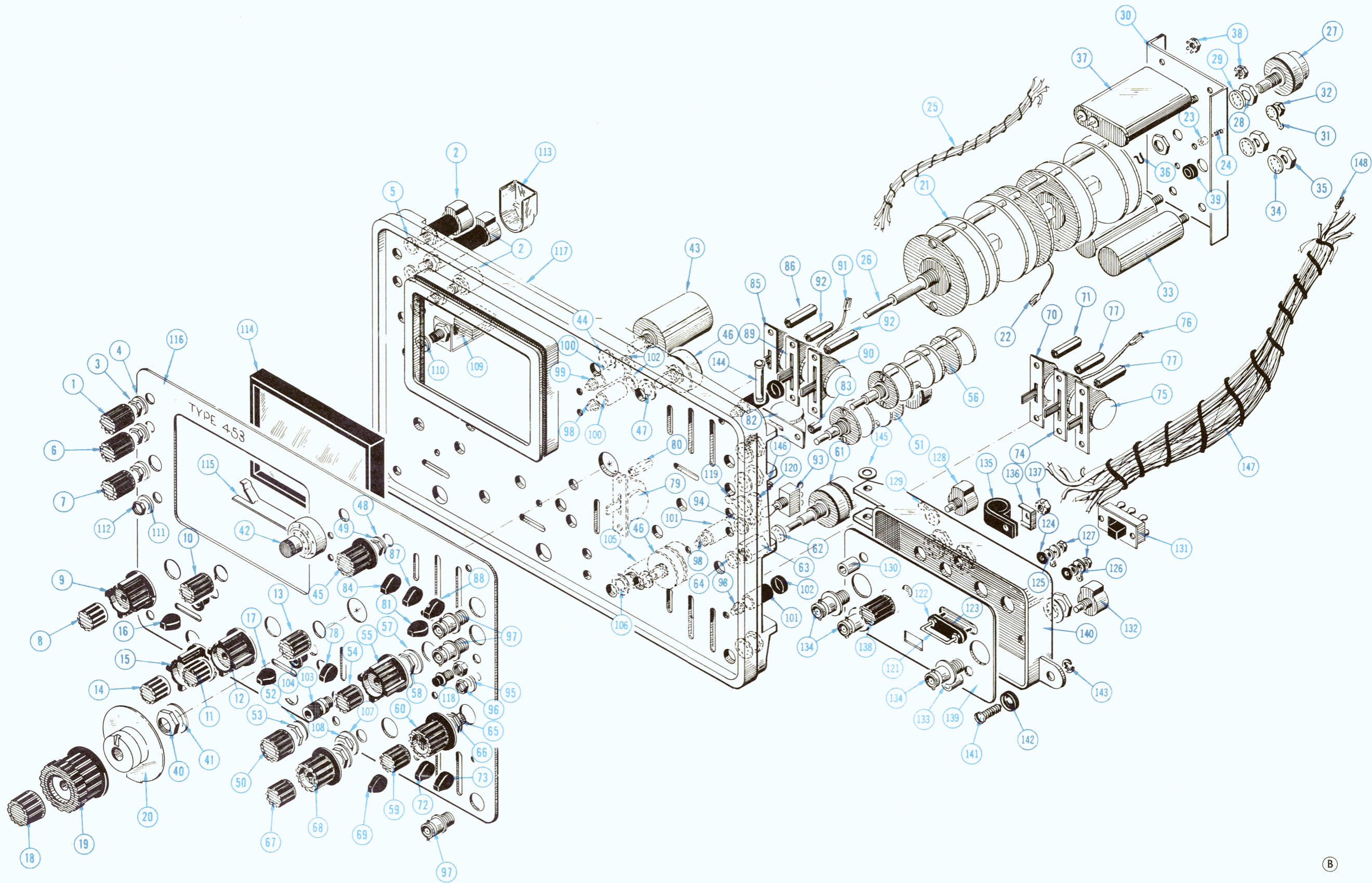

TYPE 453/R453 OSCILLOSCOPE

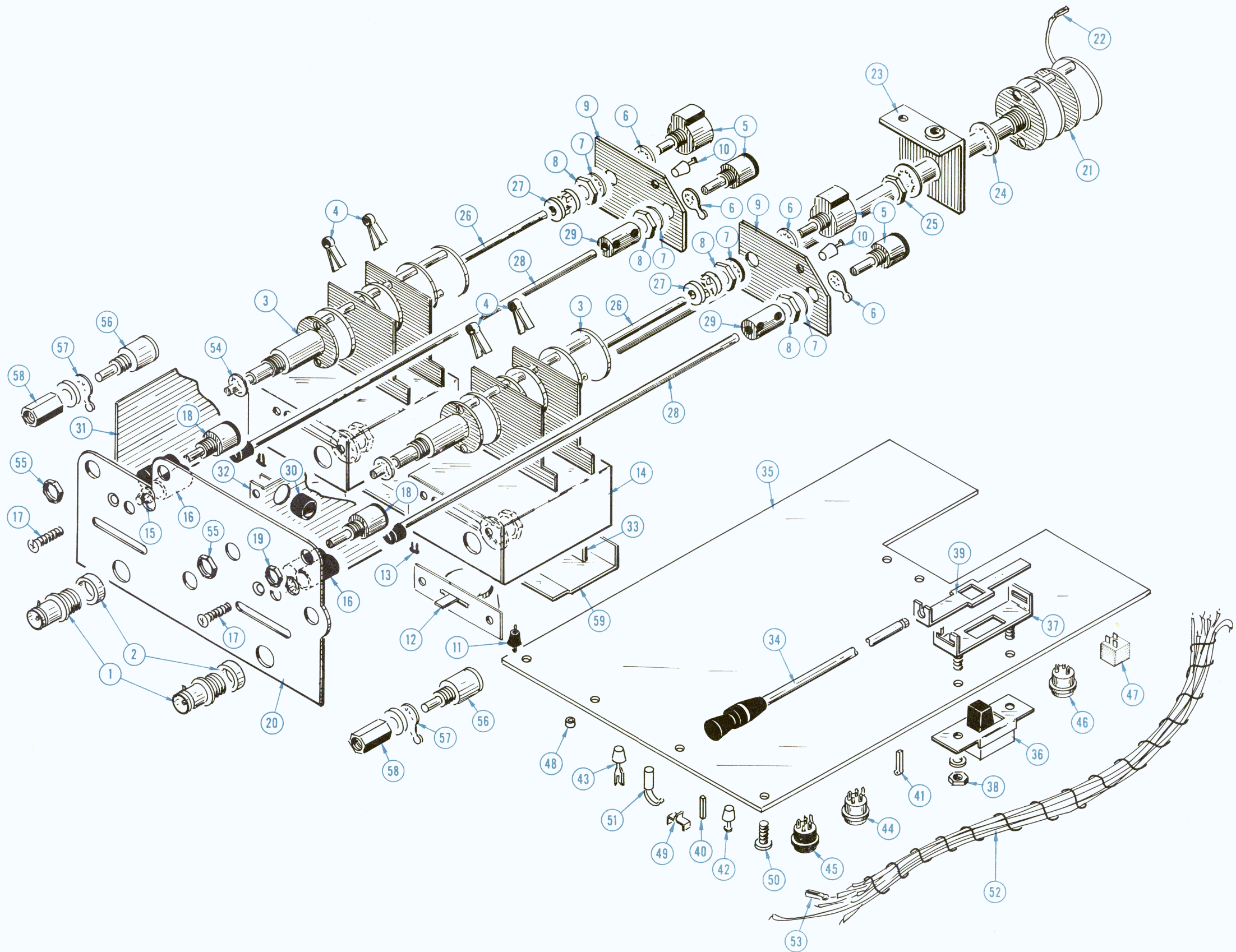

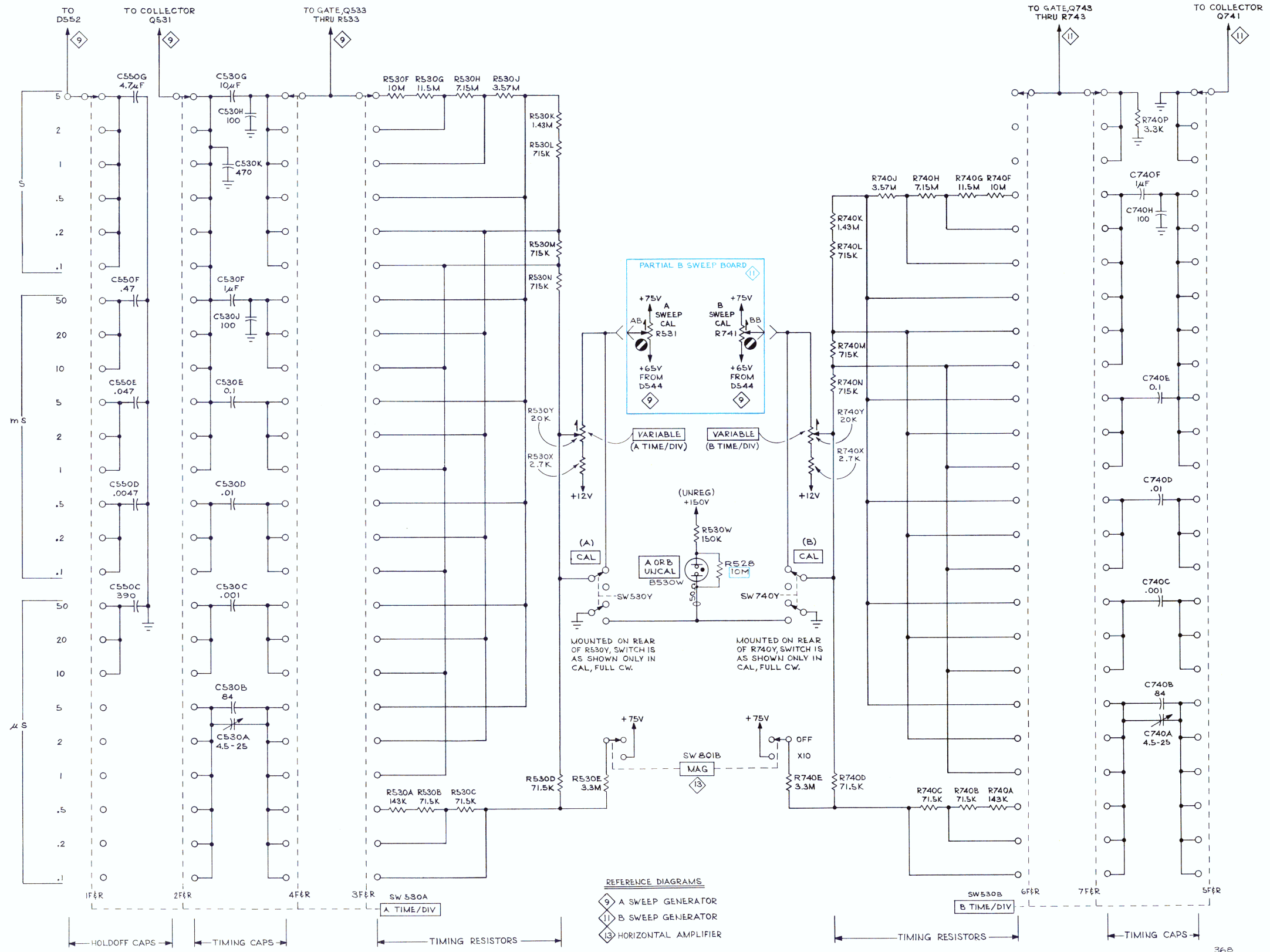

REFERENCE DIAGRAMS
 9 A SWEEP GENERATOR
 11 B SWEEP GENERATOR
 13 HORIZONTAL AMPLIFIER

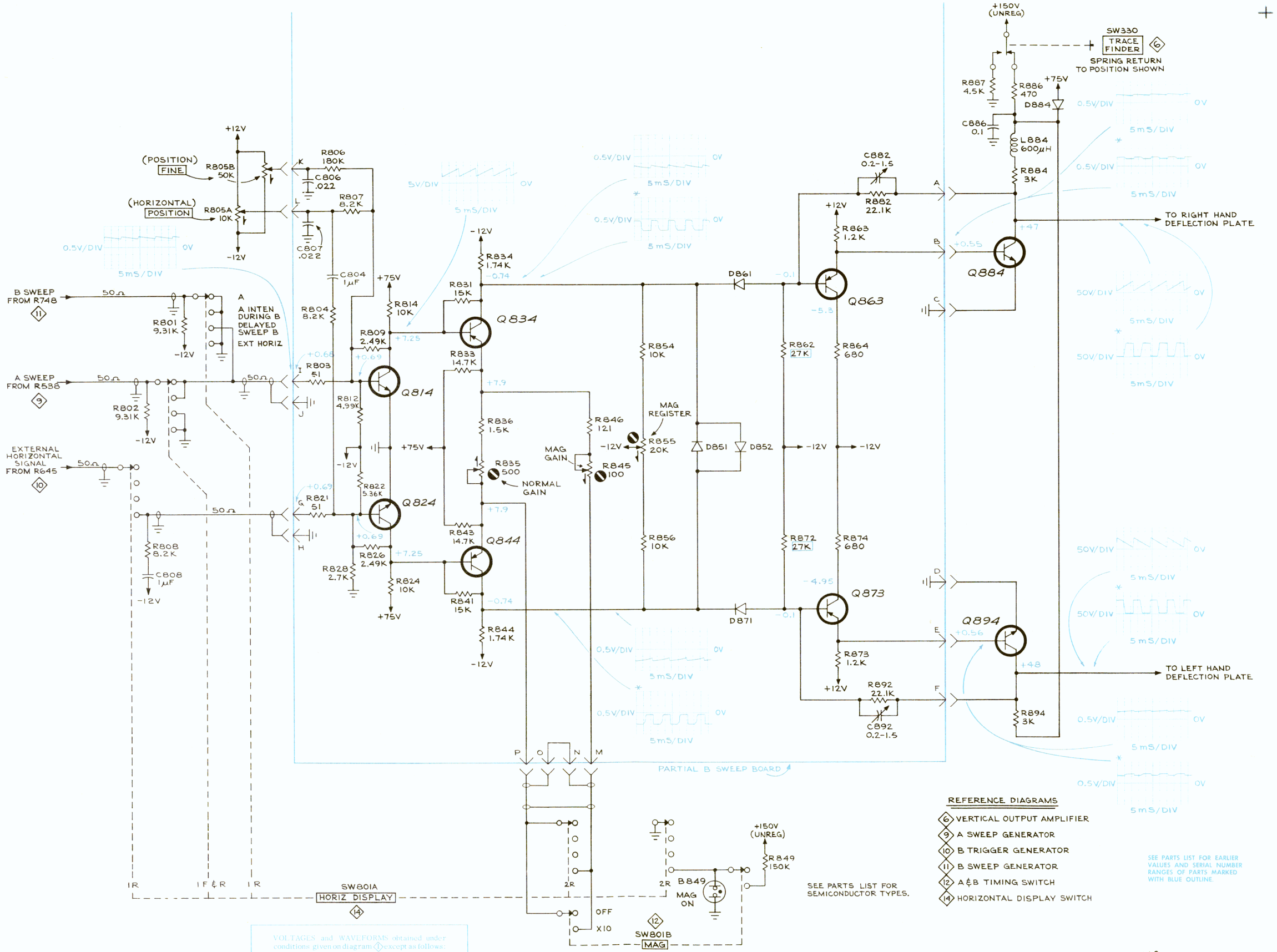

- REFERENCE DIAGRAMS**
- ⑥ VERTICAL OUTPUT AMPLIFIER
 - ⑨ A SWEEP GENERATOR
 - ⑩ B TRIGGER GENERATOR
 - ⑪ B SWEEP GENERATOR
 - ⑫ A & B TIMING SWITCH
 - ⑬ HORIZONTAL DISPLAY SWITCH

SEE PARTS LIST FOR EARLIER VALUES AND SERIAL NUMBER RANGES OF PARTS MARKED WITH BLUE OUTLINE.

VOLTAGES and WAVEFORMS obtained under conditions given on diagram except as follows:	
* MAG	X10

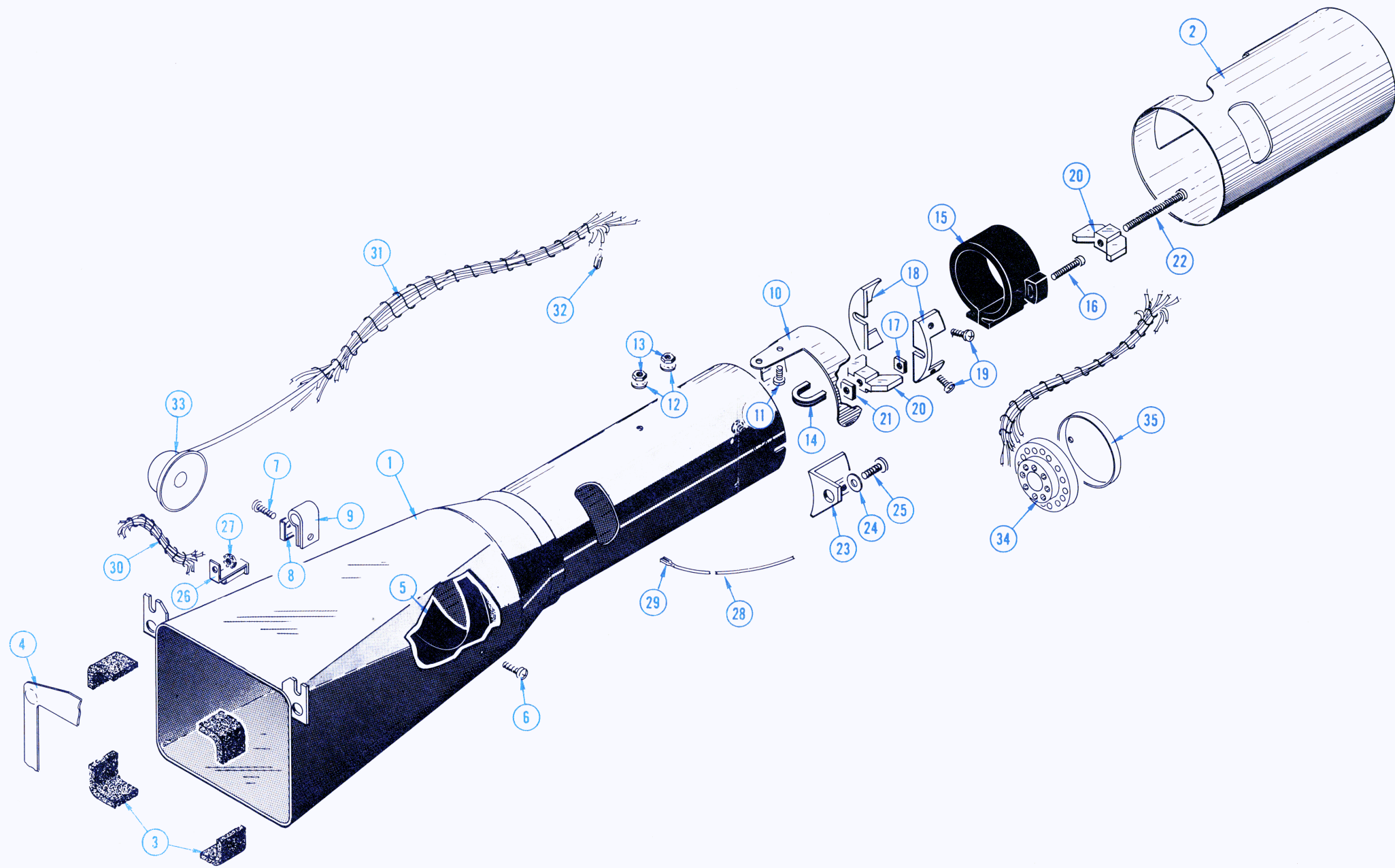

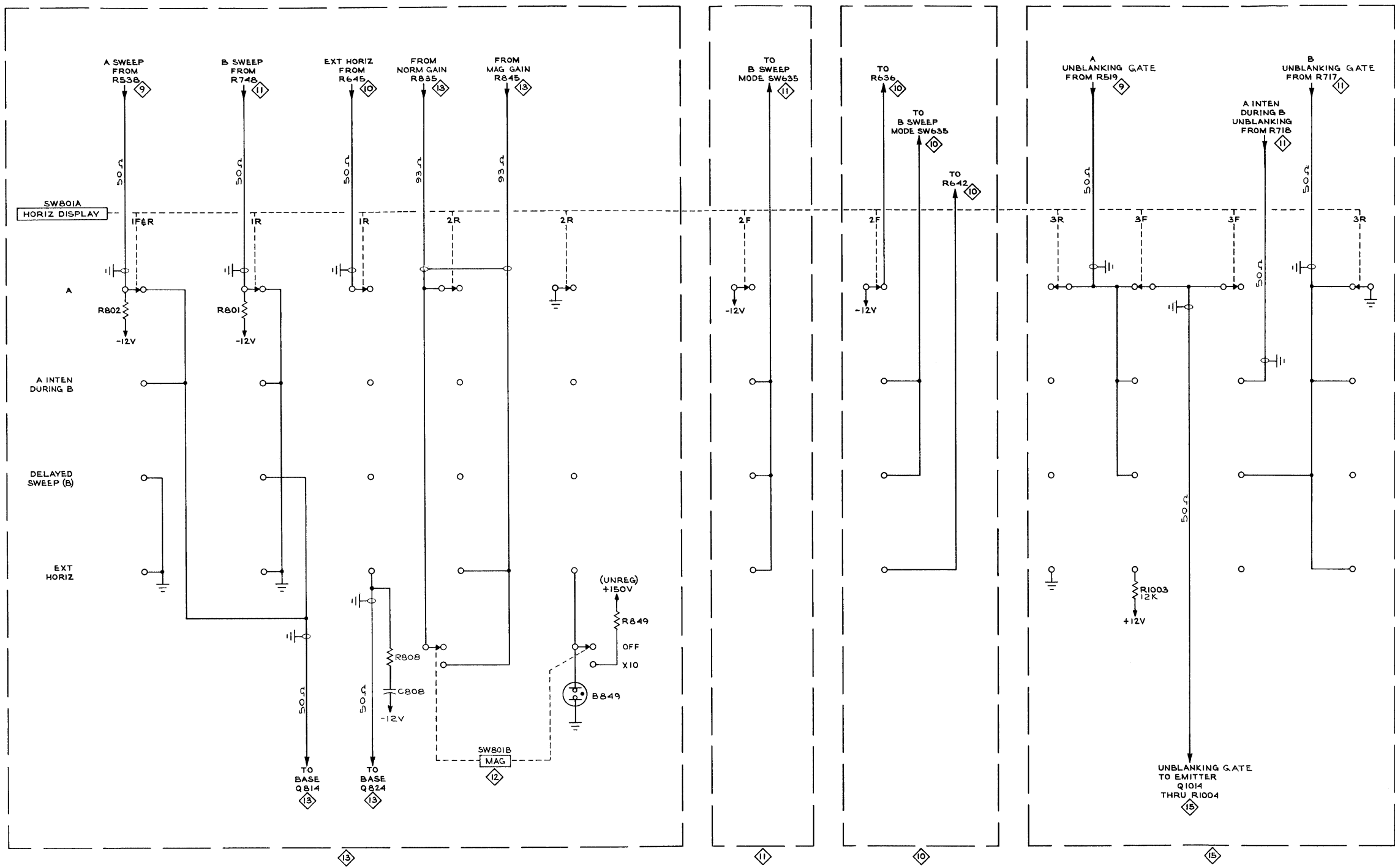

REFERENCE DIAGRAMS

- 9 A SWEEP GENERATOR
- 10 B TRIGGER GENERATOR
- 11 B SWEEP GENERATOR
- 13 HORIZONTAL AMPLIFIER
- 15 Z AXIS AMPLIFIER
- 12 A & B TIMING SWITCH

FIG. 4 A & B SWEEPS
FIG. 5 HIGH VOLTAGE ASSEMBLY

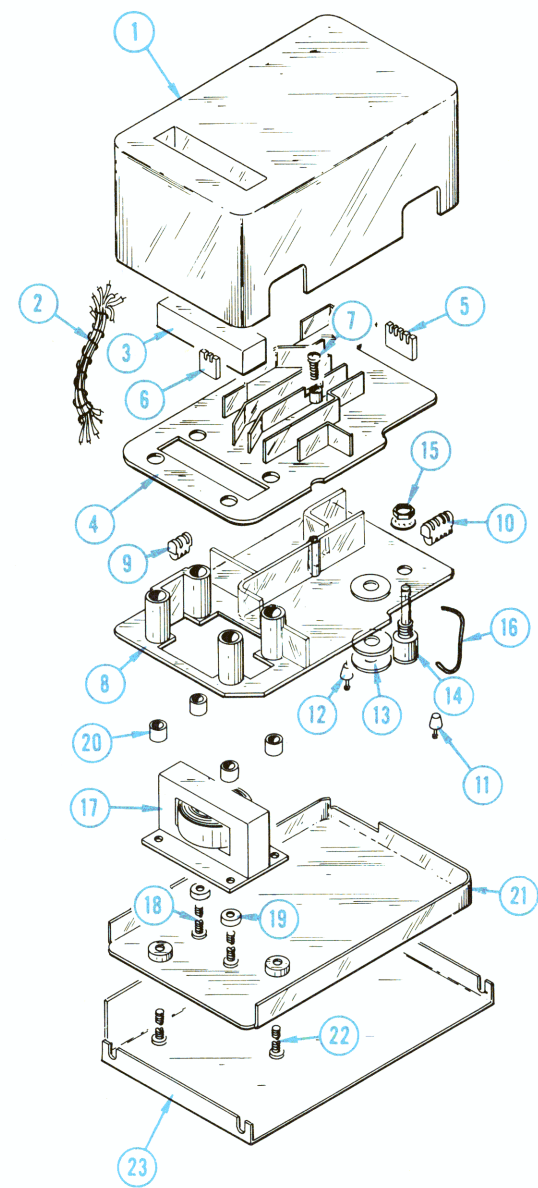
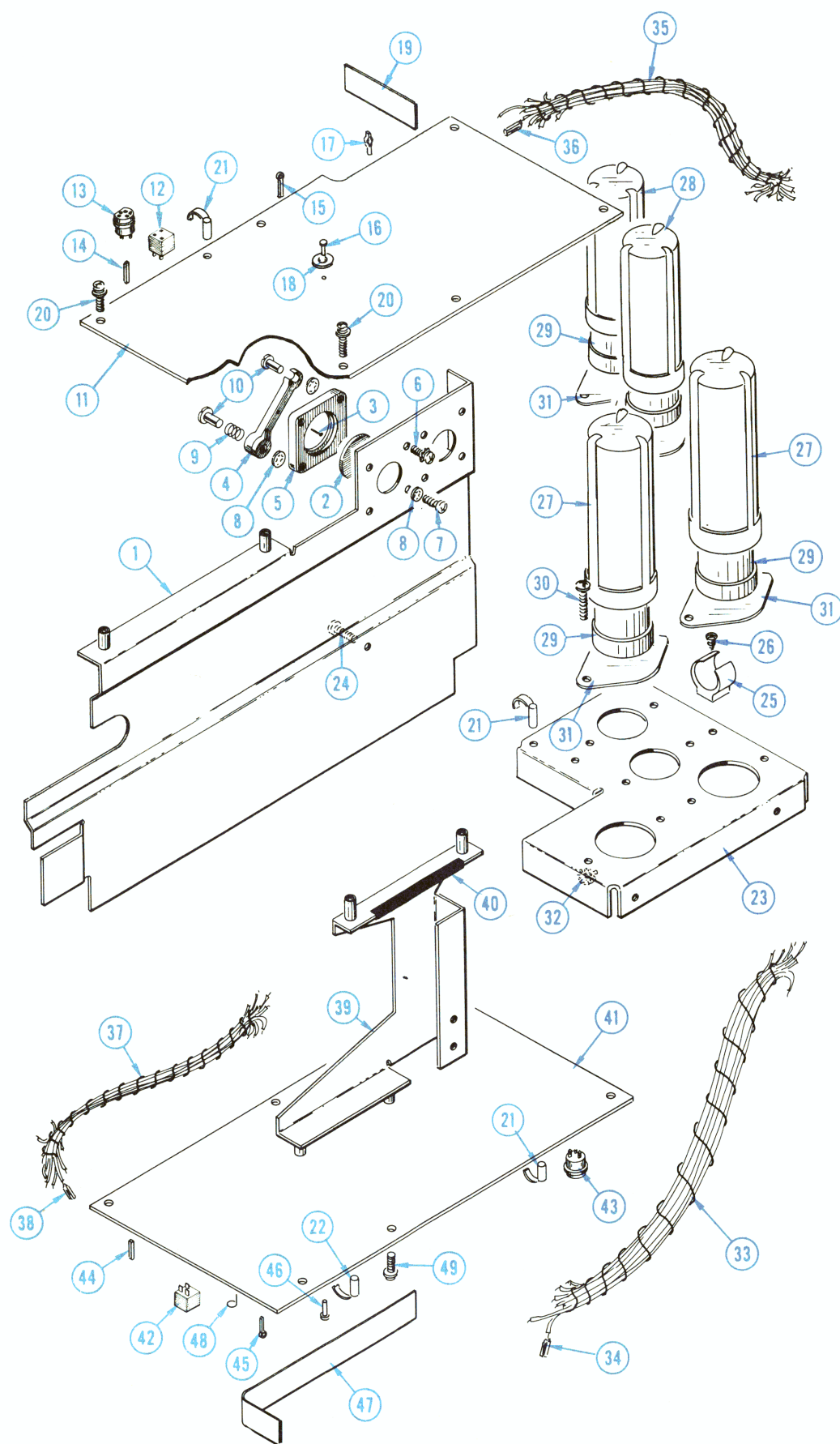

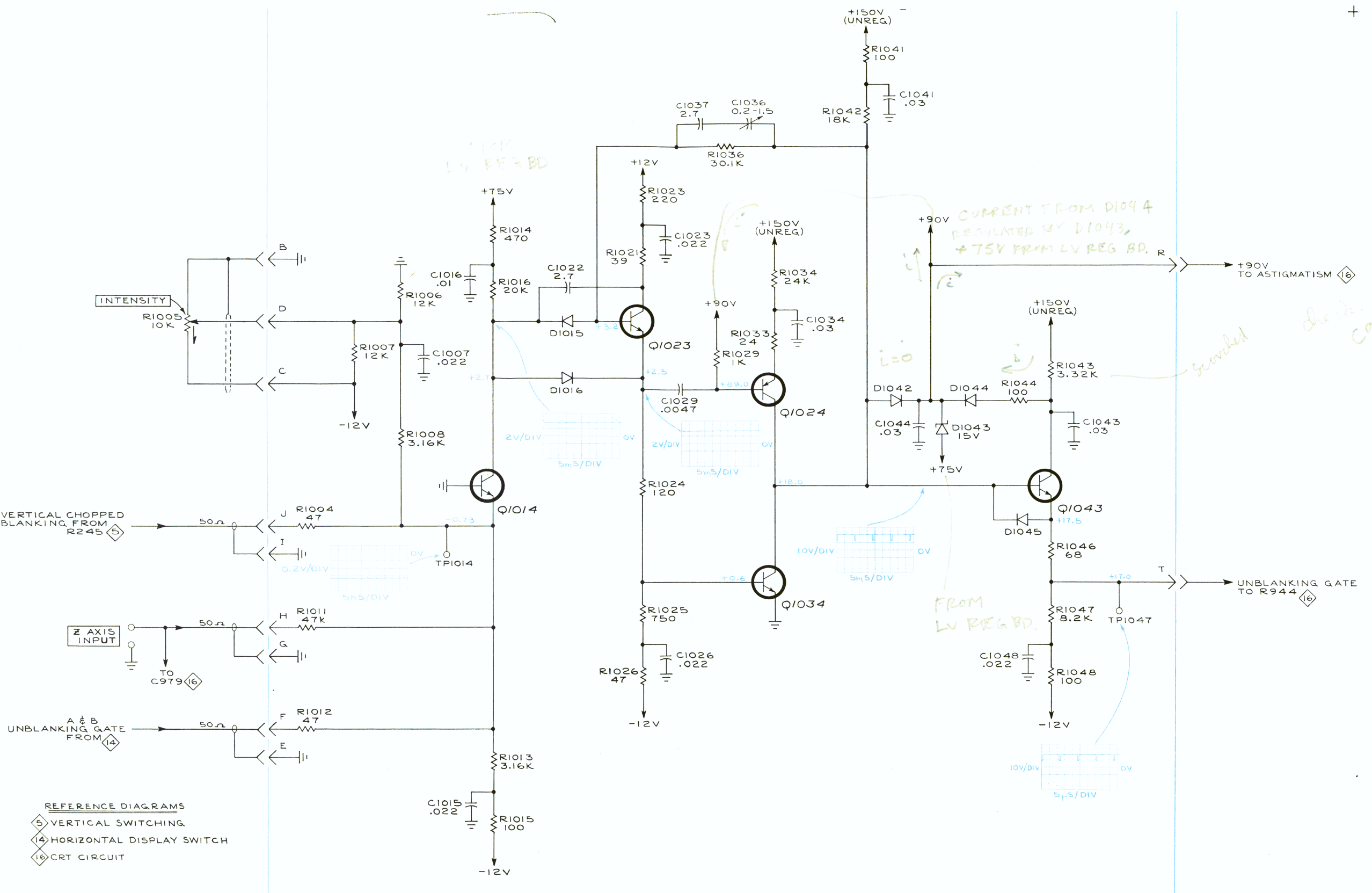

SEE PARTS LIST FOR SEMICONDUCTOR TYPES

VOLTAGES and WAVEFORMS obtained under conditions given on diagram

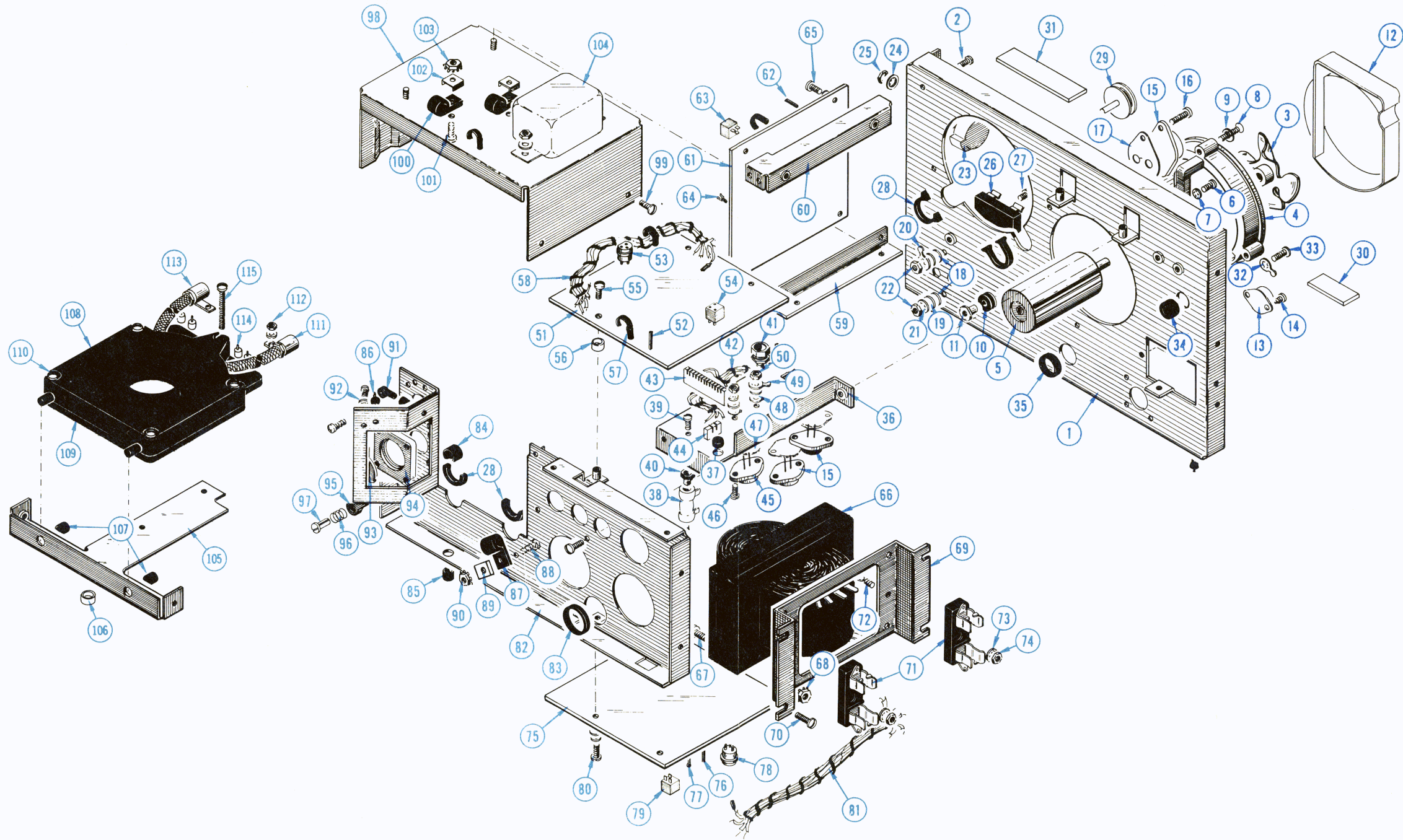

TYPE 453/R453 OSCILLOSCOPE

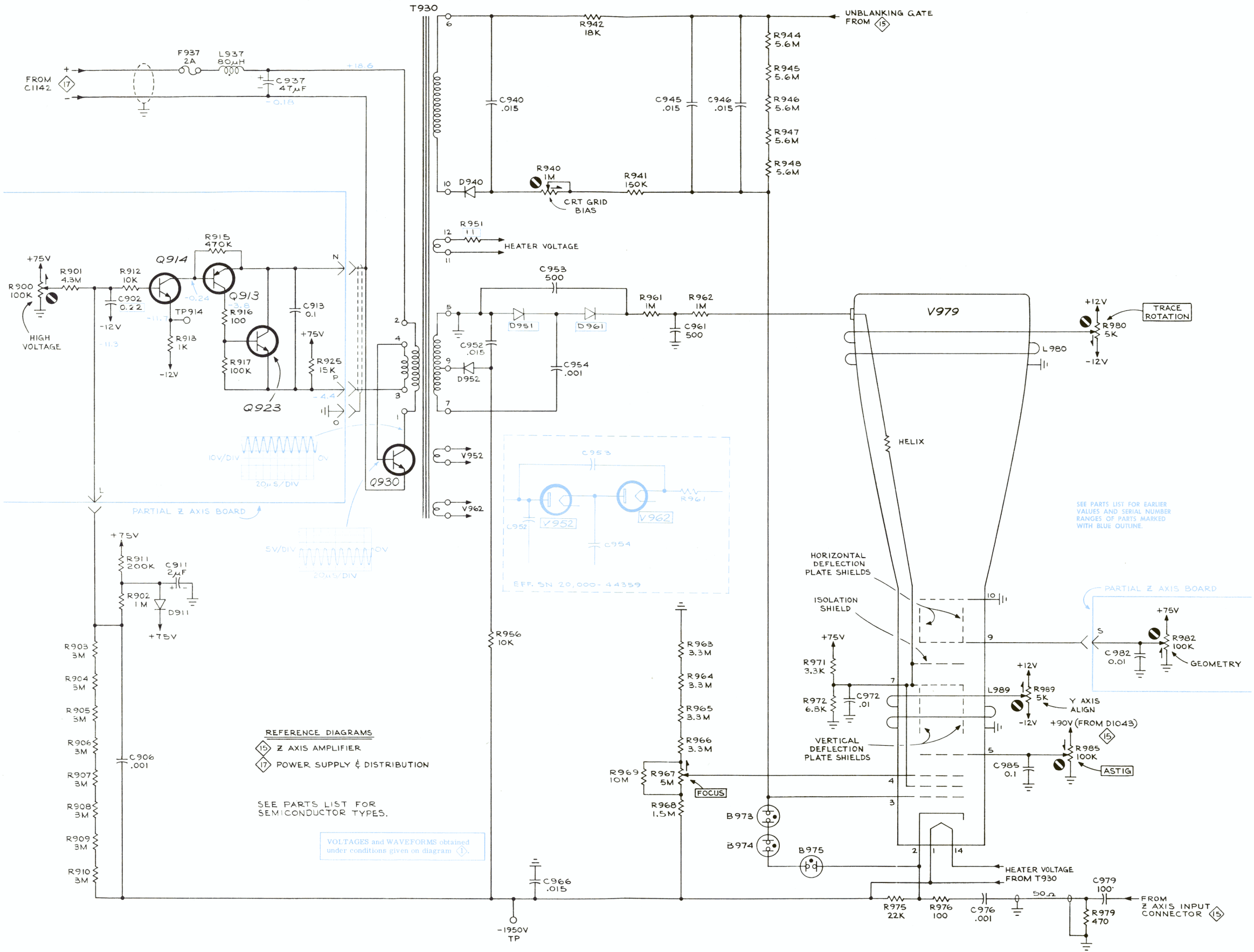

REFERENCE DIAGRAMS
 15 Z AXIS AMPLIFIER
 17 POWER SUPPLY & DISTRIBUTION

SEE PARTS LIST FOR SEMICONDUCTOR TYPES.

VOLTAGES and WAVEFORMS obtained under conditions given on diagram.

SEE PARTS LIST FOR EARLIER VALUES AND SERIAL NUMBER RANGES OF PARTS MARKED WITH BLUE OUTLINE.

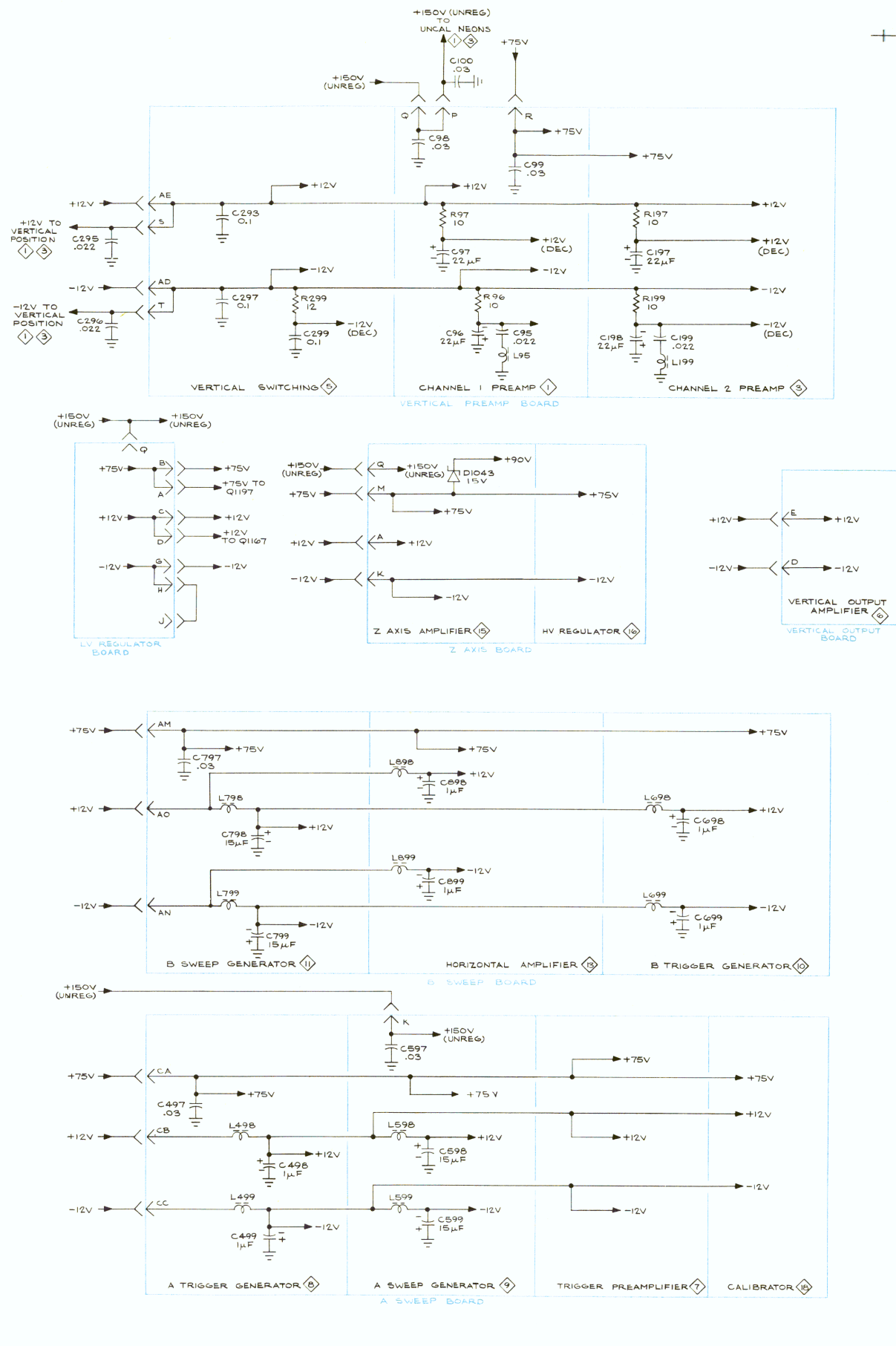
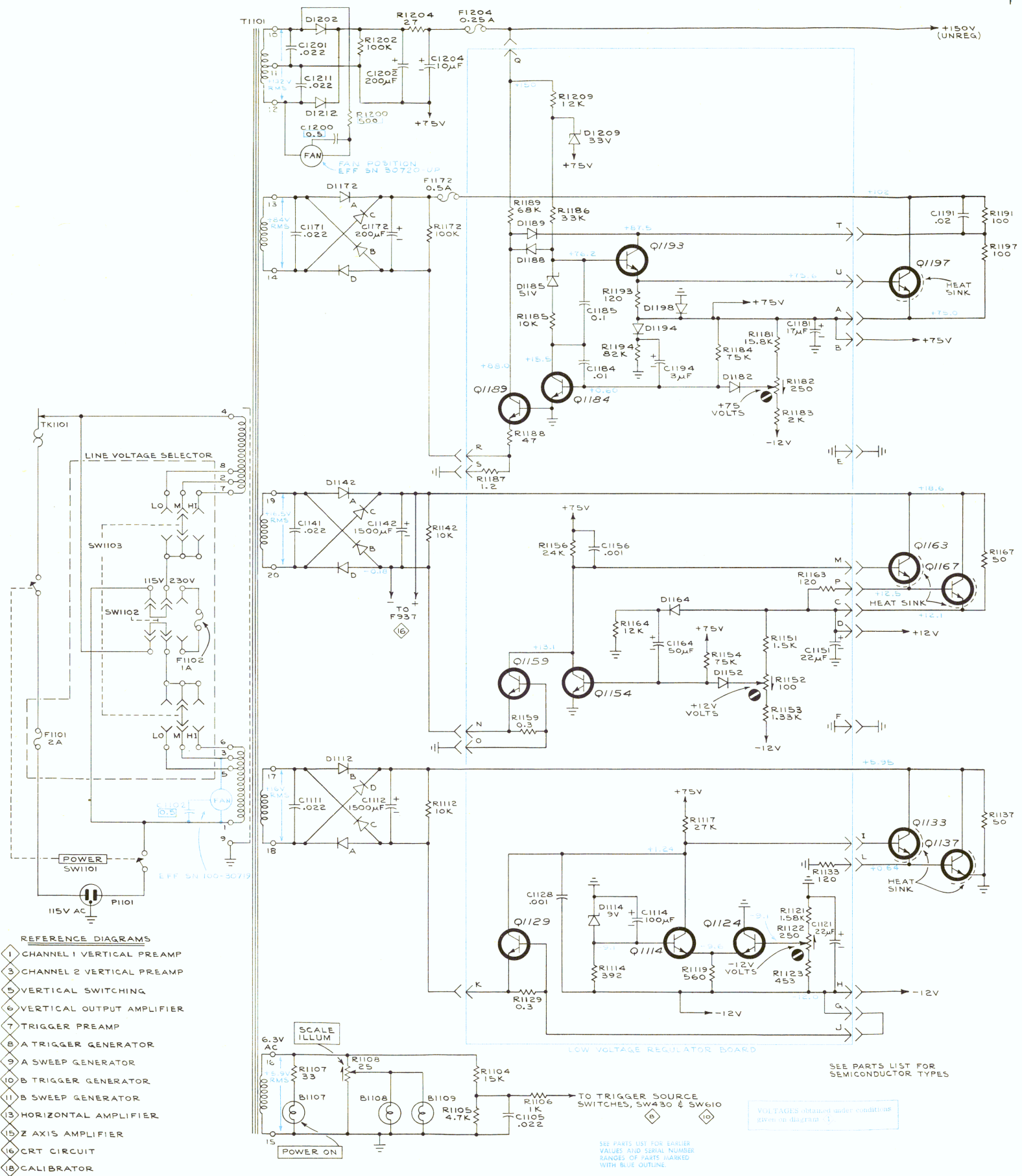

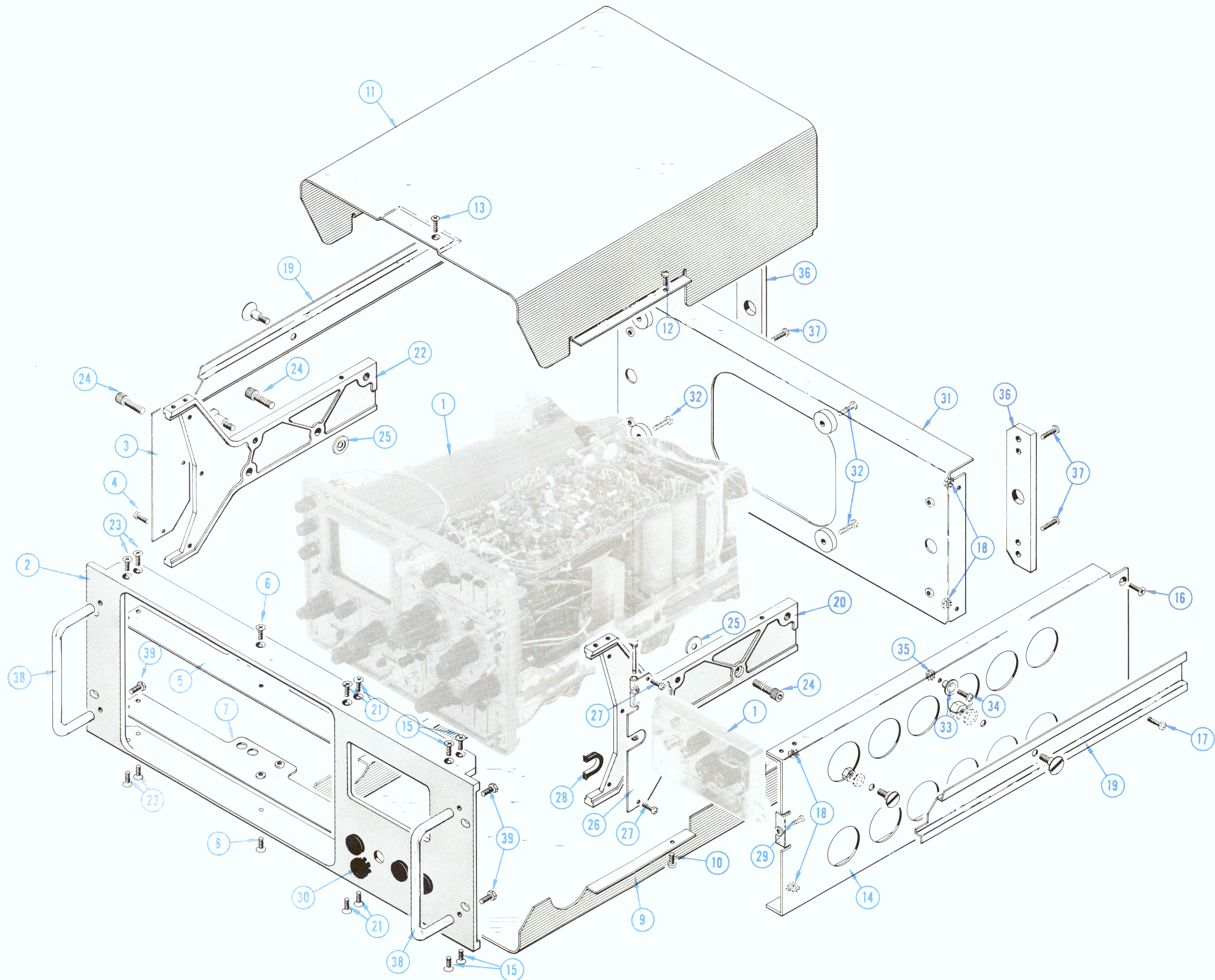

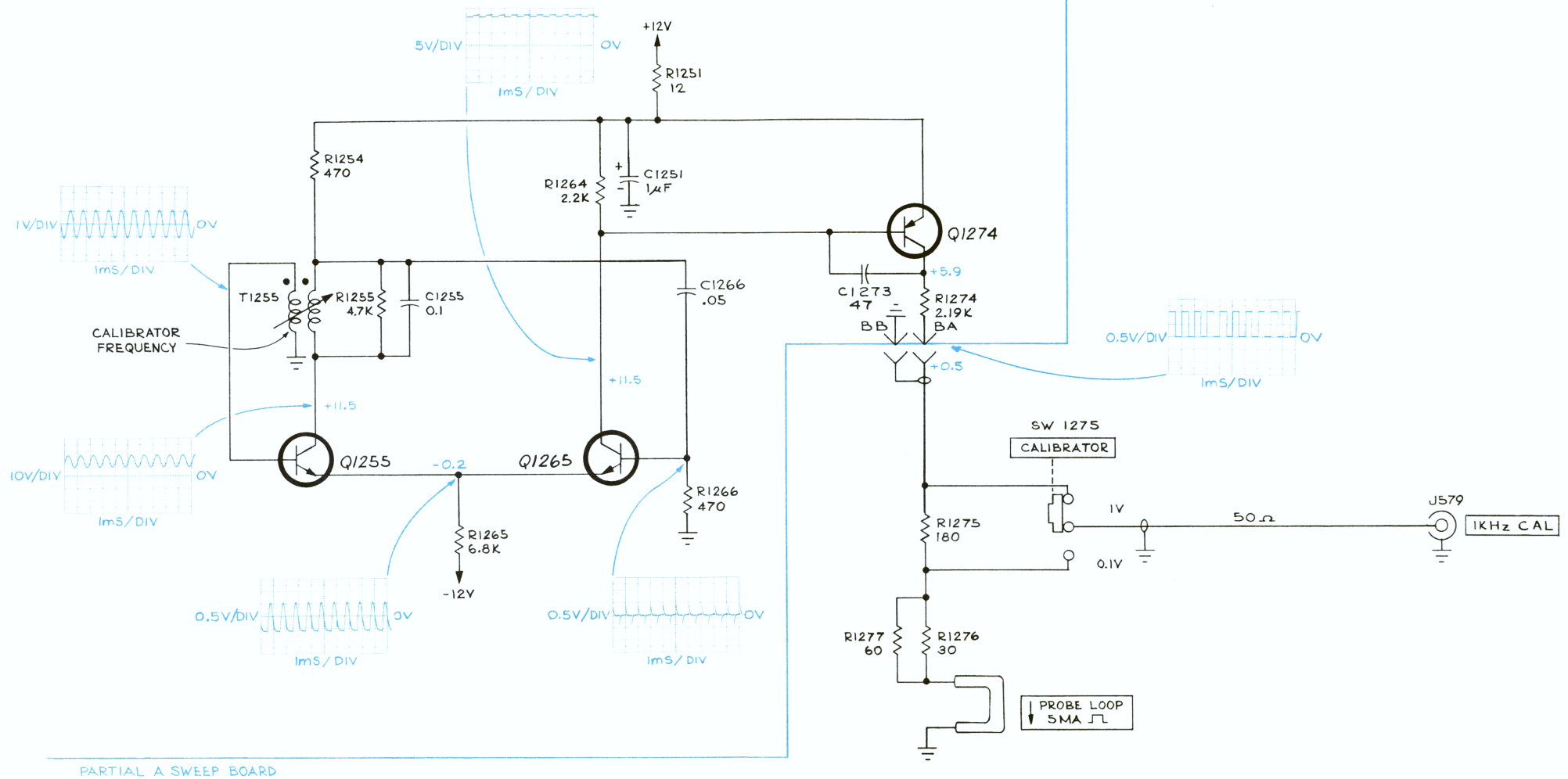

SEE PARTS LIST FOR SEMICONDUCTOR TYPES

VOLTAGES and WAVEFORMS obtained under conditions given on diagram.

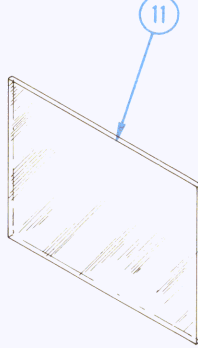
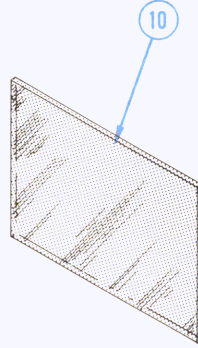
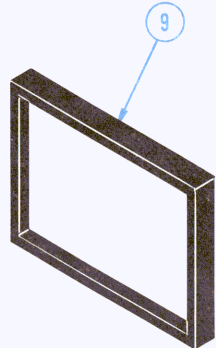
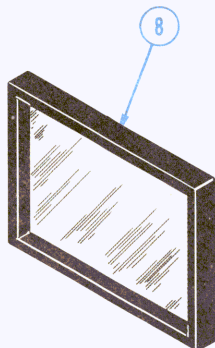
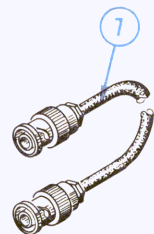
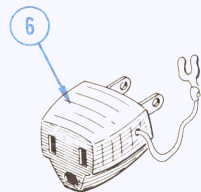
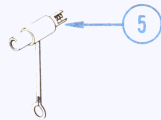
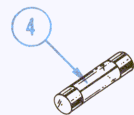
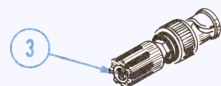
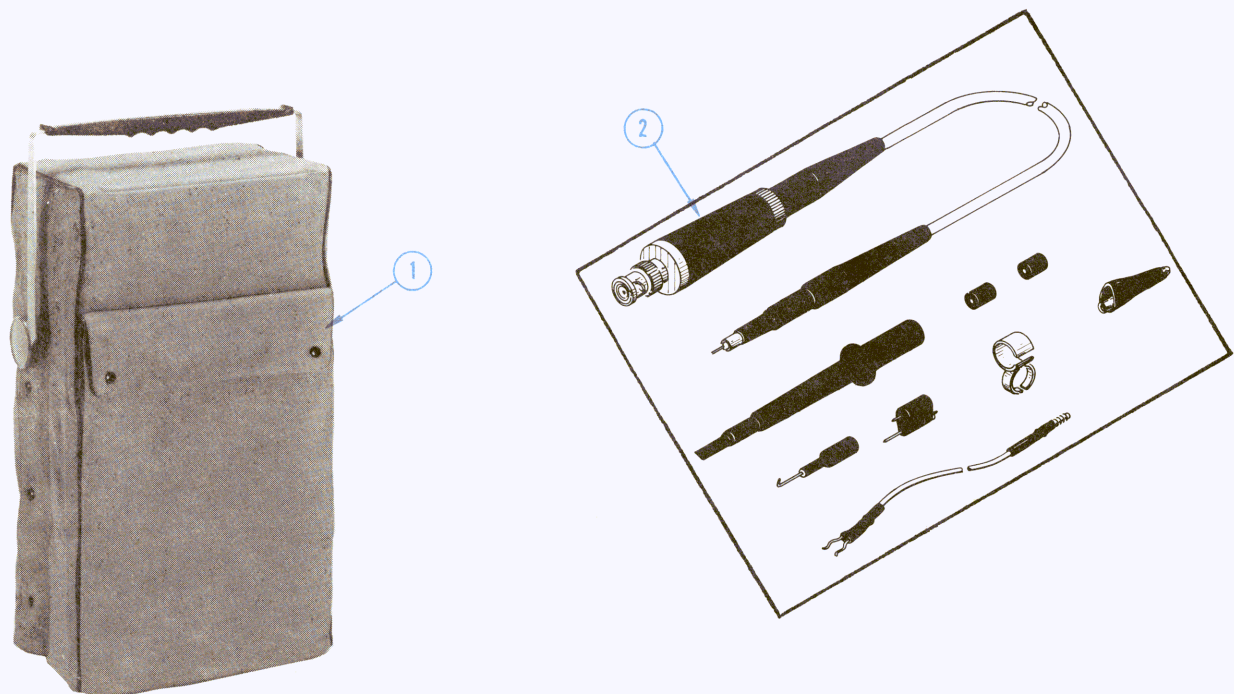

STANDARD ACCESSORIES

Fig. & Index No.	Tektronix Part No.	Serial/Model No. Eff	No. Disc	Q						Description
					y	1	2	3	4	
9-1	016-0074-01			1						COVER, rain (TYPE 453 only)
-2	010-0188-00			2						PROBE PACKAGE, P6010
-3	103-0033-00			2						ADAPTER, BNC to binding post
-4	159-0021-00			2						FUSE, fast-blo, 2 amp, 3AG
	159-0022-00			1						FUSE, fast-blo, 1 amp, 3AG
	159-0025-00			1						FUSE, fast-blo, 1/2 amp, 3AG
	159-0028-00			1						FUSE, fast-blo, 1/4 amp, 3AG
-5	012-0092-00			1						JACK, BNC-post
-6	103-0013-00			1						ADAPTER, power cord, 3 to 2 wire
-7	012-0076-00			1						CABLE, BNC, 18 inch
-8	378-0573-00	20000	34971	1						FILTER, mesh (installed)
	378-0623-00	34972		1						FILTER, mesh (installed)
-9	354-0269-00			1						RING, ornamental, CRT
-10	378-0576-00			1						FILTER, light, smoke gray
-11	386-0218-00			1						PLATE, protector, CRT
	070-0755-02			2						MANUAL, instruction (not shown)

OTHER PARTS FURNISHED WITH R453

016-0096-00	1	KIT, hardware (not shown)
016-0099-00	1	KIT, rackmounting hardware (not shown)
351-0101-00	1 pr.	TRACK, slide, stationary & inter-second (not shown)

FIGURE AND INDEX NUMBERS

Items in this section are referenced by figure and index numbers to the illustrations which appear on the pullout pages immediately following the Diagrams section of this instruction manual.

INDENTATION SYSTEM

This mechanical parts list is indented to indicate item relationships. Following is an example of the indentation system used in the Description column.

Assembly and/or Component
Detail Part of Assembly and/or Component
mounting hardware for Detail Part
Parts of Detail Part
mounting hardware for Parts of Detail Part
mounting hardware for Assembly and/or Component

Mounting hardware always appears in the same indentation as the item it mounts, while the detail parts are indented to the right. Indented items are part of, and included with, the next higher indentation.

Mounting hardware must be purchased separately, unless otherwise specified.

PARTS ORDERING INFORMATION

Replacement parts are available from or through your local Tektronix, Inc. Field Office or representative.

Changes to Tektronix instruments are sometimes made to accommodate improved components as they become available, and to give you the benefit of the latest circuit improvements developed in our engineering department. It is therefore important, when ordering parts, to include the following information in your order: Part number, instrument type or number, serial or model number, and modification number if applicable.

If a part you have ordered has been replaced with a new or improved part, your local Tektronix, Inc. Field Office or representative will contact you concerning any change in part number.

Change information, if any, is located at the rear of this manual.

ABBREVIATIONS AND SYMBOLS

For an explanation of the abbreviations and symbols used in this section, please refer to the page immediately preceding the Electrical Parts List in this instruction manual.

INDEX OF MECHANICAL PARTS ILLUSTRATIONS

Title	Location (reverse side of)
FIG. 1 FRONT	B SWEEP GENERATOR
FIG. 2 ATTENUATOR PREAMPLIFIER ASSEMBLY	A & B TIMING SWITCH
FIG. 3 CRT SHIELD	HORIZONTAL AMPLIFIER
FIG. 4 A & B SWEEPS/FIG. 5 HIGH VOLTAGE ASSEMBLY .	HORIZ DISPLAY SWITCH
FIG. 6 REAR CHASSIS	Z AXIS AMPLIFIER
FIG. 7 FRAME & CABINET	CRT CIRCUIT
FIG. 8 R453 MECHANICAL PARTS	POWER SUPPLY & DISTRIBUTION
FIG. 9 453/R453 ACCESSORIES	CALIBRATOR

SECTION 9

MECHANICAL PARTS LIST

FIG. 1 FRONT

Fig. & Index No.	Tektronix Part No.	Serial/Model No. Eff	No. Disc	Q					Description	
				t	Y	1	2	3		4
1-1	366-0153-00			1						KNOB, charcoal—INTENSITY
	- - - - -			-						knob includes:
	213-0004-00			1						SCREW, set, 6-32 x 3/16 inch, HSS
-2	- - - - -			3						RESISTOR, variable
	- - - - -			-						mounting hardware for each: (not included w/resistor)
-3	210-0583-00			2						NUT, hex., 1/4-32 x 5/16 inch
-4	210-0940-00			1						WASHER, flat, 1/4 ID x 3/8 inch OD
-5	210-0046-00			1						LOCKWASHER, internal, 1/4 ID x 0.400 inch OD
-6	366-0153-00			1						KNOB, charcoal—FOCUS
	- - - - -			-						knob includes:
	213-0004-00			1						SCREW, set, 6-32 x 3/16 inch, HSS
-7	366-0153-00			1						KNOB, charcoal—SCALE ILLUM
	- - - - -			-						knob includes:
	213-0004-00			1						SCREW, set, 6-32 x 3/16 inch, HSS
-8	366-0189-00			1						KNOB, red—VARIABLE (CH 1)
	- - - - -			-						knob includes:
	213-0020-00			1						SCREW, set, 6-32 x 1/8 inch, HSS
-9	366-0322-00			1						KNOB, charcoal—VOLTS/DIV (CH 1)
	- - - - -			-						knob includes:
	213-0004-00			1						SCREW, set, 6-32 x 3/16 inch, HSS
-10	366-0153-00			1						KNOB, charcoal—POSITION (CH 1)
	- - - - -			-						knob includes:
	213-0004-00			1						SCREW, set, 6-32 x 3/16 inch, HSS
-11	366-0189-00			1						KNOB, red—VARIABLE (CH 2)
	- - - - -			-						knob includes:
	213-0020-00			1						SCREW, set, 6-32 x 1/8 inch, HSS
-12	366-0322-00			1						KNOB, charcoal—VOLTS/DIV (CH 2)
	- - - - -			-						knob includes:
	213-0004-00			1						SCREW, set, 6-32 x 3/16 inch, HSS
-13	366-0153-00			1						KNOB, charcoal—POSITION (CH 2)
	- - - - -			-						knob includes:
	213-0004-00			1						SCREW, set, 6-32 x 3/16 inch, HSS
-14	366-0189-00			1						KNOB, red—TRIGGER
	- - - - -			-						knob includes:
	213-0020-00			1						SCREW, set, 6-32 x 1/8 inch, HSS
-15	366-0322-00			1						KNOB, charcoal—MODE
	- - - - -			-						knob includes:
	213-0004-00			1						SCREW, set, 6-32 x 3/16 inch, HSS
-16	366-0215-01			1						KNOB, charcoal—AC GND DC (CH 1)
-17	366-0215-01			1						KNOB, charcoal—AC GND DC (CH 2)
-18	366-0038-00			1						KNOB, red—A VARIABLE
	- - - - -			-						knob includes:
	213-0004-00			1						SCREW, set, 6-32 x 3/16 inch, HSS
-19	366-0194-00			1						KNOB, charcoal—B TIME/DIV
	- - - - -			-						knob includes:
	213-0004-00			1						SCREW, set, 6-32 x 3/16 inch, HSS

Mechanical Parts List—Type 453/R453

FIG. 1 FRONT (cont)

Fig. & Index No.	Tektronix Part No.	Serial/Model No. Eff	No. Disc	Q					Description	
				y	1	2	3	4		5
1-20	331-0092-00			1						DIAL, window knob—A TIME/DIV
	- - - - -			-						dial includes:
	213-0022-00			1						SCREW, set, 4-40 x 3/16 inch, HSS
-21	262-0724-01			1						SWITCH, wired—A AND B TIME/DIV
	- - - - -			-						switch includes:
	260-0694-00			1						SWITCH, unwired
-22	131-0371-00			9						CONNECTOR, single contact, female
-23	131-0181-00			2						CONNECTOR, terminal standoff
	- - - - -			-						mounting hardware for each: (not included w/connector)
-24	358-0136-00			1						BUSHING, plastic
-25	179-1122-00			1						CABLE HARNESS
-26	384-0262-00			1						ROD, extension
-27	- - - - -			1						RESISTOR, variable
	- - - - -			-						mounting hardware: (not included w/resistor)
-28	210-0413-00			2						NUT, hex., 3/8-32 x 1/2 inch
-29	210-0012-00			1						LOCKWASHER, internal, 3/8 ID x 1/2 inch OD
-30	407-0148-00			1						BRACKET
	- - - - -			-						mounting hardware: (not included w/bracket)
	210-0006-00			1						LOCKWASHER, internal, #6 (not shown)
-31	210-0202-00			1						LUG, solder, SE #6
-32	210-0449-00			2						NUT, hex., 5-40 x 1/4 inch
-33	- - - - -			2						CAPACITOR
	- - - - -			-						mounting hardware for each: (not included w/capacitor)
-34	210-0018-00			1						LOCKWASHER, internal, 5/16 inch
-35	210-0524-00			1						NUT, hex., 5/16-24 x 1/2 inch
-36	376-0014-00			1						COUPLING
	361-0233-00	X36500		1						RESTRAINT, shaft coupling
	361-0234-00	X36500		1						RESTRAINT, shaft coupling
-37	- - - - -			1						CAPACITOR
	- - - - -			-						mounting hardware: (not included w/capacitor)
-38	210-0457-00			2						NUT, keps, 6-32 x 5/16 inch
-39	348-0055-00			1						GROMMET, plastic, 1/4 inch
	- - - - -			-						mounting hardware: (not included w/switch)
	211-0507-00			2						SCREW, 6-32 x 5/16 inch, PHS (not shown)
-40	210-0049-00			1						LOCKWASHER, internal, 5/8 inch
-41	210-0579-00			1						NUT, hex., 5/8-24 x 3/4 inch
-42	331-0139-00			1						DIAL—DELAY TIME MULTIPLIER
	- - - - -			-						dial includes:
	213-0048-00			1						SCREW, set, 4-40 x 1/8 inch, HSS
-43	- - - - -			1						RESISTOR, variable
	- - - - -			-						mounting hardware: (not included w/resistor)
-44	210-0012-00			1						LOCKWASHER, internal, 3/8 ID x 1/2 inch OD
-45	366-0220-00			1						KNOB, charcoal—LEVEL (B TRIGGERING)
	- - - - -			-						knob includes:
	213-0020-00			1						SCREW, set, 6-32 x 1/8 inch, HSS

FIG. 1 FRONT (cont)

Fig. & Index No.	Tektronix Part No.	Serial/Model Eff	No. Disc	Q					Description
				y	1	2	3	4	
1-46	- - - - -			2					RESISTOR, variable
	- - - - -			-					mounting hardware for each: (not included w/resistor)
-47	210-0012-00			1					LOCKWASHER, internal, $\frac{3}{8}$ ID x $\frac{1}{2}$ inch OD
-48	210-0978-00			1					WASHER, flat, $\frac{3}{8}$ ID x $\frac{1}{2}$ inch OD
-49	210-0590-00			1					NUT, hex., $\frac{3}{8}$ -32 x $\frac{7}{16}$ inch
-50	366-0148-00			1					KNOB, charcoal—A SWEEP LENGTH
	- - - - -			-					knob includes:
	213-0004-00			1					SCREW, set, 6-32 x $\frac{3}{16}$ inch, HSS
-51	262-0726-02			1					SWITCH, wired—A SWEEP LENGTH
	- - - - -			-					switch includes:
	260-0697-01			1					SWITCH, unwired
	- - - - -			1					RESISTOR, variable
	- - - - -			-					mounting hardware: (not included w/resistor)
	210-0012-00			1					LOCKWASHER, internal, $\frac{3}{8}$ ID x $\frac{1}{2}$ inch OD
	210-0590-00			2					NUT, hex., $\frac{3}{8}$ -32 x $\frac{7}{16}$ inch
	376-0014-00			1					COUPLING
	- - - - -			-					mounting hardware: (not included w/switch)
-52	210-0978-00			1					WASHER, flat, $\frac{3}{8}$ ID x $\frac{1}{2}$ inch OD
-53	210-0590-00			1					NUT, hex., $\frac{3}{8}$ -32 x $\frac{7}{16}$ inch
-54	366-0189-00			1					KNOB, red—MAG
	- - - - -			-					knob includes:
	213-0020-00			1					SCREW, set, 6-32 x $\frac{1}{8}$ inch, HSS
-55	366-0322-00			1					KNOB, charcoal—HORIZ DISPLAY
	- - - - -			-					knob includes:
	213-0004-00			1					SCREW, set, 6-32 x $\frac{3}{16}$ inch, HSS
-56	262-0725-02			1					SWITCH, wired—HORIZ DISPLAY
	- - - - -			-					switch includes:
	260-0696-00			1					SWITCH, unwired
	179-0993-01	X33320		1					CABLE HARNESS, horizontal display A
	179-0994-00	X33320		1					CABLE HARNESS, horizontal display B
	- - - - -			-					mounting hardware: (not included w/switch)
-57	210-0978-00			1					WASHER, flat, $\frac{3}{8}$ ID x $\frac{1}{2}$ inch OD
-58	210-0590-00			1					NUT, hex., $\frac{3}{8}$ -32 x $\frac{7}{16}$ inch
-59	366-0319-00			1					KNOB, red—FINE
	- - - - -			-					knob includes:
	213-0020-00			1					SCREW, set, 6-32 x $\frac{1}{8}$ inch, HSS
-60	366-0138-00			1					KNOB, charcoal—POSITION
	- - - - -			-					knob includes:
	213-0004-00			1					SCREW, set, 6-32 x $\frac{3}{16}$ inch, HSS

Mechanical Parts List—Type 453/R453

FIG. 1 FRONT (cont)

Fig. & Index No.	Tektronix Part No.	Serial/Model Eff	No. Disc	Q					Description	
				t	y	1	2	3		4
1-61	- - - - -			1						RESISTOR, variable
	- - - - -			-						mounting hardware: (not included w/resistor)
-62	210-0012-00			1						LOCKWASHER, internal, $\frac{3}{8}$ -32 x $\frac{1}{2}$ inch OD
-63	210-0494-00	20000	26129	1						NUT, hex., $\frac{3}{8}$ -32 x $\frac{1}{2}$ x $\frac{1}{16}$ inch OD
	129-0167-00	26130		1						POST, metallic
	210-0013-00	20000	22039	1						LOCKWASHER, internal, $\frac{3}{8}$ ID x $\frac{1}{16}$ inch OD
-64	210-0012-00	22040	26129X	1						LOCKWASHER, internal, $\frac{3}{8}$ ID x $\frac{1}{2}$ inch OD
-65	210-0840-00			1						WASHER, flat, 0.390 ID x $\frac{9}{16}$ inch OD
-66	358-0029-05			1						BUSHING, hex., $\frac{1}{2}$ inch long
-67	366-0319-00			1						KNOB, red—HF STAB
	- - - - -			-						knob includes:
	213-0020-00			1						SCREW, set, 6-32 x $\frac{1}{8}$ inch, HSS
-68	366-0138-00			1						KNOB, charcoal—LEVEL (A TRIGGERING)
	- - - - -			-						knob includes:
	213-0004-00			1						SCREW, set, 6-32 x $\frac{3}{16}$ inch, HSS
-69	366-0215-01			1						KNOB, charcoal—SLOPE (A TRIGGERING)
-70	260-0472-00			1						SWITCH, lever—SLOPE (A TRIGGERING)
	- - - - -			-						mounting hardware: (not included w/switch)
-71	220-0413-00			2						NUT, switch, 4-40 x $\frac{3}{16}$ x 0.562 inch
-72	366-0215-01			1						KNOB, charcoal—COUPLING (A TRIGGERING)
-73	366-0215-01			1						KNOB, charcoal—SOURCE (A TRIGGERING)
	262-0723-00			1						SWITCH, wired—COUPLING & SOURCE
	- - - - -			-						switch includes:
-74	260-0700-00			1						SWITCH, lever—COUPLING
-75	260-0698-01			1						SWITCH, lever—SOURCE
-76	131-0371-00			2						CONNECTOR, single contact, female
	- - - - -			-						mounting hardware: (not included w/switch)
-77	220-0413-00			4						NUT, switch, 4-40 x $\frac{3}{16}$ x 0.562 inch
-78	366-0215-01			1						KNOB, charcoal—A SWEEP MODE
-79	260-0699-00			1						SWITCH, lever—A SWEEP MODE
	- - - - -			-						mounting hardware: (not included w/switch)
-80	220-0413-00			2						NUT, switch, 4-40 x $\frac{3}{16}$ x 0.562 inch
-81	366-0215-01			1						KNOB, charcoal—B SWEEP MODE
-82	260-0587-00			1						SWITCH, lever—B SWEEP MODE
	- - - - -			-						mounting hardware: (not included w/switch)
-83	220-0413-00			2						NUT, switch, 4-40 x $\frac{3}{16}$ x 0.562 inch
-84	366-0215-01			1						KNOB, charcoal—SLOPE (B TRIGGERING)
-85	260-0472-00			1						SWITCH, lever—SLOPE (B TRIGGERING)
	- - - - -			-						mounting hardware: (not included w/switch)
-86	220-0413-00			2						NUT, switch, 4-40 x $\frac{3}{16}$ x 0.562 inch

FIG. 1 FRONT (cont)

Fig. & Index No.	Tektronix Part No.	Serial/Model No. Eff	No. Disc	Q					Description		
				t	y	1	2	3		4	5
1-87	366-0215-01			1						1	KNOB, charcoal—COUPLING (B TRIGGERING)
-88	366-0215-01			1						1	KNOB, charcoal—SOURCE (B TRIGGERING)
	262-0723-00			1						1	SWITCH, wired—COUPLING & SOURCE
	- - - - -			-							switch includes:
-89	260-0700-00			1						1	SWITCH, lever—COUPLING
-90	260-0698-01			1						1	SWITCH, lever—SOURCE
-91	131-0371-00			2							CONNECTOR, single contact, female
	- - - - -			-							mounting hardware: (not included w/switch)
-92	220-0413-00			4							NUT, switch, 4-40 x 3/16 x 0.562 inch
-93	260-0834-00			1							SWITCH, toggle—POWER ON
	- - - - -			-							mounting hardware: (not included w/switch)
-94	210-0046-00			1							LOCKWASHER, internal, 1/4 ID x 0.400 inch OD
-95	210-0940-00			1							WASHER, flat, 1/4 ID x 3/8 inch OD
-96	210-0562-00			1							NUT, hex., 1/4-40 x 5/16 inch
-97	131-0352-01			3							CONNECTOR, coaxial, 1 contact BNC, (w/hardware)
-98	378-0541-00			4							FILTER, lens, clear
-99	378-0541-01			1							FILTER, lens, green
-100	352-0084-00			2							HOLDER, neon, black
-101	352-0084-01			3							HOLDER, neon, white
-102	200-0609-00			5							COVER, neon holder
-103	129-0103-00			1							ASSEMBLY, binding post
	- - - - -			-							assembly includes:
	200-0103-00			1							CAP
	129-0077-00			1							POST
	- - - - -			-							mounting hardware: (not included w/assembly)
	210-0046-00			1							LOCKWASHER, internal, 1/4 ID x 0.400 inch OD
	210-0455-00			1							NUT, hex., 1/4-28 x 3/8 inch
-104	358-0216-00			2							BUSHING, gray
-105	260-0717-00			1							SWITCH, push—RESET
	- - - - -			-							mounting hardware: (not included w/switch)
-106	210-0012-00			1							LOCKWASHER, internal, 3/8 ID x 1/2 inch OD
-107	210-0978-00			1							WASHER, flat, 3/8 ID x 1/2 inch OD
-108	210-0590-00			1							NUT, hex., 3/8-32 x 7/16 inch
-109	260-0688-00			1							SWITCH, push—TRACE FINDER
	- - - - -			-							mounting hardware: (not included w/switch)
-110	210-0011-00			1							LOCKWASHER, internal, 1/4 ID x 15/32 inch OD
-111	210-0940-00			1							WASHER, flat, 1/4 ID x 3/8 inch OD
-112	210-0583-00			2							NUT, hex., 1/4-32 x 5/16 inch
-113	200-0608-00			1							COVER, variable resistor
-114	- - - - -			1							FILTER, mesh (See Standard Accessories Page)

FIG. 1 FRONT (cont)

Fig. & Index No.	Tektronix Part No.	Serial/Model No.		Q	Description
		Eff	Disc		
				t	
				y	1 2 3 4 5
1-115	214-0654-00	20000	25629	1	SPRING, filter
	214-0996-00	25630		1	SPRING, filter
-116	333-0891-00			1	PANEL, front
-117	386-0208-00			1	PLATE, sub-panel front
-118	136-0223-00			1	SOCKET, light
	- - - - -			-	mounting hardware: (not included w/socket)
-119	210-0223-00			1	LUG, solder, 1/4 ID x 7/16 inch OD, SE
-120	210-0562-00			1	NUT, hex., 1/4-40 x 5/16 inch
-121	214-0335-00			1	BOLT, current loop
	- - - - -			-	mounting hardware: (not included w/bolt)
-122	210-0593-00			2	NUT, hex., 3-48 x 1/4 inch
-123	361-0059-00			1	SPACER
-124	210-0849-00			2	WASHER, fiber, shouldered, #4
-125	210-0994-00			2	WASHER, flat, 0.125 ID x 0.250 inch OD
-126	210-0201-00			2	LUG, solder, SE #4
-127	210-0442-00			2	NUT, hex., 3-48 x 3/16 inch
-128	- - - - -			1	RESISTOR, variable
	- - - - -			-	mounting hardware: (not included w/resistor)
-129	210-0223-00			1	LUG, solder, 1/4 inch
-130	358-0075-00			1	BUSHING
-131	260-0447-00			1	SWITCH, slide—CALIBRATOR
	- - - - -			-	mounting hardware: (not included w/switch)
	210-0406-00			2	NUT, hex., 4-40 x 3/16 inch
-132	- - - - -			1	RESISTOR, variable
	- - - - -			-	mounting hardware: (not included w/resistor)
-133	358-0075-00			1	BUSHING
-134	131-0274-00			3	CONNECTOR, coaxial, BNC (w/hardware)
-135	343-0005-00			1	CLAMP, cable, plastic, 7/16 inch
	- - - - -			-	mounting hardware: (not included w/clamp)
-136	210-0863-00			1	WASHER, "D" shape, 0.191 ID x 33/64 x 33/64 inch long
-137	210-0457-00			1	NUT, keps, 6-32 x 5/16 inch
-138	366-0236-00			1	KNOB, charcoal—B TIME/DIV
	- - - - -			-	knob includes:
	213-0193-00			1	SCREW, set, 4-40 x 3/32 inch, HSS
-139	333-0977-00			1	PANEL, front (calibrator frame)
-140	426-0267-00			1	FRAME, calibrator

FIG. 1 FRONT (cont)

Fig. & Index No.	Tektronix Part No.	Serial/Model Eff	No. Disc	Q					Description	
				t	y	1	2	3		4
1-141	211-0598-00			1						SCREW, captive, 6-32 x 3/8 inch, FHS
-142	210-0869-00			1						WASHER, plastic, 5/32 ID x 3/8 inch OD
-143	354-0163-00			1						RING, retaining
-144	214-0573-00			1						PIN, hinge
-145	210-0805-00			1						WASHER, flat, 0.204 ID x 0.438 inch OD
-146	354-0165-00			1						RING, retaining
-147	179-0996-01			1						CABLE HARNESS, main
	- - - - -			-						cable harness includes:
-148	131-0371-00			12						CONNECTOR, single contact, female
	179-0993-01	20000	33319X	1						CABLE HARNESS, horizontal display A

FIG. 2 ATTENUATOR PREAMPLIFIER ASSEMBLY

Fig. & Index No.	Tektronix Part No.	Serial/Model Eff	No. Disc	Q					Description	
				t	1	2	3	4		5
2-	644-0413-01			1						ASSEMBLY, attenuator preamplifier
-1	131-0352-00			2						assembly includes: CONNECTOR, coaxial, 1 contact, BNC, female w/mounting hardware mounting hardware for each: (not included w/connector)
-2	166-0402-00			1						SPACER, BNC connector
	644-0412-01	20000	22529	2						ASSEMBLY, attenuator switch and chassis (CH 1 & CH 2) each assembly includes:
-3	262-0728-01			1						SWITCH, wired—VOLTS/DIV switch includes:
	260-0720-01	20000	37259	1						SWITCH, unwired
	260-0720-02	37260		1						SWITCH, unwired
-4	214-0599-00			2						SPRING, switch shaft ground
-5				2						RESISTOR, variable mounting hardware for each: (not included w/resistor)
-6	210-0223-00			1						LUG, solder, 1/4 ID x 7/16 inch OD, SE
-7	210-0046-00			1						LOCKWASHER, internal, 1/4 ID x 0.400 inch OD
-8	210-0583-00			1						NUT, hex., 1/4-32 x 5/16 inch
-9	386-1284-00			1						PLATE, mounting, plastic mounting hardware: (not included w/plate)
	210-0053-00			2						LOCKWASHER, split, #2 (not shown)
	210-0405-00			2						NUT, hex., 2-56 x 3/16 inch (not shown)
-10	131-0157-00			1						CONNECTOR, terminal, stand off
	610-0473-01			1						ASSEMBLY, attenuator chassis assembly includes:
-11	131-0180-00	20000	35439	1						CONNECTOR, terminal
	131-0181-00	35440		1						CONNECTOR, terminal mounting hardware: (not included w/connector)
	358-0135-00	20000	35439	1						BUSHING, plastic, (not shown)
	358-0136-00	35440		1						BUSHING, plastic, (not shown)
-12	260-0621-00			1						SWITCH, lever—AC GND DC mounting hardware: (not included w/switch)
	211-0105-00			2						SCREW, 4-40 x 3/16 inch, 100° csk, FHS (not shown)
	210-0004-00			2						LOCKWASHER, internal, #4 (not shown)
	210-0406-00			2						NUT, hex., 4-40 x 3/16 inch (not shown)
-13	214-0456-00			5						FASTENER, press, plastic
-14	441-0639-00			1						CHASSIS, attenuator
	343-0001-00	X24830		1						CLAMP, cable, plastic (not shown)
	210-0851-00	X24830		1						WASHER, flat, 0.119 ID x 3/8 inch OD (not shown)
	262-0728-02	22530		1						SWITCH, wired—VOLTS/DIV switch includes:
	260-0720-01			1						SWITCH, unwired
	214-0599-00			2						SPRING, switch
				2						RESISTOR, variable mounting hardware for each: (not included w/resistor)
	210-0223-00	22530		1						LUG, solder, 1/4 ID x 7/16 inch OD, SE
	210-0046-00	22530		1						LOCKWASHER, internal, 1/4 ID x 0.400 inch OD
	210-0583-00	22530		1						NUT, hex., 1/4-32 x 5/16 inch
	386-1284-00	22530		1						PLATE, mounting, plastic mounting hardware: (not included w/plate)
	210-0053-00	22530		2						LOCKWASHER, split, #2
	210-0405-00	22530		2						NUT, hex., 2-56 x 3/16 inch
	131-0157-00	22530		2						CONNECTOR, terminal, stand off

FIG. 2 ATTENUATOR PREAMPLIFIER ASSEMBLY (cont)

Fig. & Index No.	Tektronix Part No.	Serial/Model No. Eff	No. Disc	Q † y	1 2 3 4 5					Description
					1	2	3	4	5	
-2	610-0473-01	22530		1						ASSEMBLY, attenuator chassis
	- - - - -			-						assembly includes:
	337-0769-00	X22530		2						SHIELD, attenuator
	131-0180-00			1						CONNECTOR, terminal
	- - - - -			-						mounting hardware: (not shown w/connector)
	358-0135-00			1						BUSHING, plastic (not shown)
	260-0621-00			1						SWITCH, lever—AC GND DC
	- - - - -			-						mounting hardware: (not included w/switch)
	211-0105-00			2						SCREW, 4-40 x 3/16 inch, 100° csk, FHS
	210-0004-00			2						LOCKWASHER, internal, #4
	210-0406-00			2						NUT, hex., 4-40 x 3/16 inch
	214-0456-00			5						FASTENER, press, plastic
	441-0539-00			1						CHASSIS, attenuator
	343-0001-00	X24830		1						CLAMP, cable, plastic
	210-0851-00	X24830		1						WASHER, flat, 0.119 ID x 3/8 inch OD
-15	378-0541-00			2						FILTER, lens, clear
-16	352-0067-00			2						HOLDER, neon, single
	- - - - -			-						mounting hardware for each: (not included w/holder)
-17	211-0109-00			1						SCREW, 4-40 x 7/8 inch, 100° csk, FHS
	210-0406-00			2						NUT, hex., 4-40 x 3/16 inch (not shown)
-18	- - - - -			2						RESISTOR, variable
	- - - - -			-						mounting hardware: (not included w/resistor)
-19	210-0583-00			1						NUT, hex., 1/4-32 x 3/16 inch
-20	386-0225-00			1						PLATE, attenuator
-21	262-0727-01			1						SWITCH, wired—MODE
	- - - - -			-						switch includes:
	260-0695-01			1						SWITCH, unwired
-22	131-0371-00			8						CONNECTOR, single contact, female
-23	407-0157-00			1						BRACKET, switch
-24	210-0012-00			2						LOCKWASHER, internal, 3/8 ID x 1/2 inch OD
-25	210-0413-00			1						NUT, hex., 3/8-32 x 1/2 inch
-26	384-0679-00			2						SHAFT, extension
-27	376-0050-00			2						ASSEMBLY, coupling
	- - - - -			-						each assembly includes:
	354-0251-00			2						RING, coupling
	376-0046-00			1						COUPLING, plastic
	213-0022-00			4						SCREW, set, 4-40 x 3/16 inch, HSS
-28	384-0360-00			2						ROD, extension, w/gray knob
-29	376-0029-00	20000	21219	2						COUPLING, shaft
	376-0053-00	21220		1						COUPLING, shaft
	- - - - -			-						each coupling includes:
	213-0048-00			2						SCREW, set, 4-40 x 1/8 inch, HSS
-30	348-0056-00			1						GROMMET, plastic, 3/8 inch diameter
-31	337-0774-00			1						SHIELD, attenuator, side
	- - - - -			-						mounting hardware: (not included w/shield)
	210-0586-00			2						NUT, keps, 4-40 x 1/4 inch (not shown)
-32	337-0768-01			1						SHIELD, attenuator, center
	- - - - -			-						mounting hardware: (not included w/shield)
	210-0201-00			1						LUG, solder, SE #4 (not shown)
	210-0586-00			4						NUT, keps, 4-40 x 1/4 inch (not shown)
-33	337-0769-00	20000	22529X	2						SHIELD, attenuator
-34	384-0357-00			1						ROD, extension, w/knob

FIG. 2 ATTENUATOR PREAMPLIFIER ASSEMBLY (cont)

Fig. & Index No.	Tektronix Part No.	Serial/Model No.		Q t y	Description
		Eff	Disc		
2-35	670-0419-04	20000	32291	1	ASSEMBLY, circuit board—VERTICAL PREAMP
	670-0419-06	32292	44711	1	ASSEMBLY, circuit board—VERTICAL PREAMP
	670-0419-07	44712		1	ASSEMBLY, circuit board—VERTICAL PREAMP
	- - - - -			-	assembly includes:
	388-0646-01	20000	32291	1	BOARD, circuit
	388-0646-02	32292		1	BOARD, circuit
-36	260-0447-00			1	SWITCH, slide—INVERT
	- - - - -			-	mounting hardware: (not included w/switch)
-37	406-0949-00			1	BRACKET
	210-0054-00			2	LOCKWASHER, split, #4
-38	210-0406-00			2	NUT, hex., 4-40 x 3/16 inch
-39	214-0563-00			1	ACTUATOR, slide switch
-40	214-0506-00			31	PIN, connector
	131-0344-00	X32292		2	CONNECTOR, feed thru
	358-0241-00	X32292		2	BUSHING, plastic
-41	214-0579-00			8	PIN, test point
-42	131-0182-00			4	CONNECTOR, terminal, feed-thru
	- - - - -			-	mounting hardware for each: (not included w/connector)
	358-0135-00			1	BUSHING, plastic (not shown)
-43	131-0235-00			2	CONNECTOR, terminal
	- - - - -			-	mounting hardware for each: (not included w/connector)
	358-0135-00			1	BUSHING, plastic (not shown)
-44	136-0235-01			2	SOCKET, diode, 6 contact, plastic
-45	136-0235-00			2	SOCKET, diode, 6 contact
-46	136-0183-00			2	SOCKET, transistor, 3 pin
-47	136-0220-00			14	SOCKET, transistor, 3 pin
-48	136-0261-00			6	SOCKET, connector pin
-49	200-0642-00			1	CAP
	- - - - -			-	mounting hardware: (not included w/assembly)
-50	211-0116-00			5	SCREW, sems, 4-40 x 5/16 inch, PHB
-51	343-0088-00			1	CLAMP, cable
-52	179-0992-01			1	CABLE HARNESS, vertical preamp
	- - - - -			-	cable harness includes:
-53	131-0371-00			11	CONNECTOR, single contact, female
-54	210-0012-00			2	LOCKWASHER, internal, 3/8 ID x 1/2 inch OD
-55	210-0590-00			2	NUT, hex., 3/8-32 x 7/16 inch
-56	- - - - -			2	RESISTOR, variable
	- - - - -			-	mounting hardware for each: (not included w/resistor)
-57	210-0223-00			1	LUG, solder, 1/4 ID x 7/16 inch OD, SE
	210-0016-00			1	LOCKWASHER, split, 1/4 inch ID
-58	220-0440-00			1	NUT, hex., 1/4-32 x 13/32 inch
	- - - - -			-	mounting hardware: (not included w/atten preamp assembly)
	211-0116-00			3	SCREW, sems, 4-40 x 5/16 inch, PHB (not shown)
	210-1001-00			3	WASHER, flat, 0.119 ID x 3/8 inch OD (not shown)
	210-0457-00			4	NUT, keps, 6-32 x 5/16 inch (not shown)
-59	337-0767-00	20000	23849	1	SHIELD, attenuator
	337-0767-04	23850		1	SHIELD, attenuator
	- - - - -			-	mounting hardware: (not included w/shield)
	211-0007-00			5	SCREW, 4-40 x 3/16 inch, PHS (not shown)

FIG. 3 CRT SHIELD

Fig. & Index No.	Tektronix Part No.	Serial/Model No.		Q t y	Description
		Eff	Disc		
3-1	337-0754-00			1	SHIELD, CRT
-2	337-0954-01			1	SHIELD, CRT (outer)
-3	348-0070-01			4	CUSHION, CRT
-4	331-0141-00			1	MASK, graticule
-5	- - - - -			1	COIL
	- - - - -			-	mounting hardware: (not included w/coil)
-6	211-0590-00			2	SCREW, 6-32 x 1/4 inch, PHS
-7	211-0589-00			1	SCREW, 6-32 x 0.312 inch, PHS
-8	210-0863-00			1	WASHER, D shape, 0.191 ID x 33/64 x 33/64 inch long
-9	343-0042-00			1	CLAMP, cable, plastic, 5/16 inch (half)
-10	343-0131-00			1	CLAMP, coil form
	- - - - -			-	mounting hardware: (not included w/clamp)
-11	211-0590-00			2	SCREW, 6-32 x 1/4 inch, PHS
-12	210-0006-00			2	LOCKWASHER, internal, #6
-13	210-0407-00			2	NUT, hex., 6-32 x 1/4 inch
-14	358-0281-00			1	BUSHING
-15	343-0124-00			1	CLAMP, retainer
	- - - - -			-	mounting hardware: (not included w/clamp)
-16	211-0599-00			2	SCREW, 6-32 x 3/4 inch, FIL HS
-17	220-0444-00			2	NUT, square, 6-32 x 1/4 inch
-18	352-0091-01			2	HOLDER, CRT retainer
	- - - - -			-	mounting hardware for each: (not included w/holder)
-19	211-0590-00			2	SCREW, 6-32 x 1/4 inch, PHS
-20	343-0123-01			2	CLAMP, CRT retainer
-21	220-0444-00			1	NUT, square, 6-32 x 1/4 inch
-22	211-0600-00			1	SCREW, 6-32 x 2 inches, FIL HS
-23	343-0122-01			2	CLAMP
	213-0049-00			2	SCREW, 6-32 x 5/16 inch HHS (not shown)
-24	210-0949-00			2	WASHER, flat, 9/64 ID x 1/2 inch OD
-25	211-0510-00			2	SCREW, 6-32 x 3/8 inch, PHS
-26	136-0205-00			2	SOCKET, graticule lamp
	- - - - -			-	mounting hardware for each: (not included w/socket)
-27	210-0586-00			1	NUT, keps, 4-40 x 1/4 inch
-28	175-0582-00			1	WIRE, CRT lead
	175-0583-00			1	WIRE, CRT lead
	175-0584-00			1	WIRE, CRT lead
	175-0596-00			1	WIRE, CRT lead
	- - - - -			-	each wire includes:
-29	131-0049-00			1	CONNECTOR, single contact, female
-30	179-1001-00			1	CABLE HARNESS, graticule lights
-31	179-0997-02			1	CABLE HARNESS, anode
	- - - - -			-	cable harness includes:
-32	131-0371-00			9	CONNECTOR, single contact, female

FIG. 3 CRT SHIELD (cont)

Fig. & Index No.	Tektronix Part No.	Serial/Model Eff	No. Disc	Q					Description	
				t	y	1	2	3		4
3-33	131-0406-00			1						CONNECTOR, anode
	- - - - -			-						connector includes:
	131-0026-00			1						CONNECTOR, anode clip
	175-0012-00			FT						CABLE, high voltage
	200-0544-00			1						COVER, anode connector
-34	136-0227-01			1						ASSEMBLY, CRT socket
	- - - - -			-						assembly includes:
	136-0202-01			1						SOCKET, CRT
	- - - - -			-						socket includes:
	136-0202-00			1						SOCKET, CRT
	214-0464-00			14						CONTACT, CRT
-35	200-0616-00			1						COVER, CRT socket

FIG. 4 A & B SWEEPS

Fig. & Index No.	Tektronix Part No.	Serial/Model No.		Q † Y	Description
		Eff	Disc		
4-1	386-1268-00			1	SUPPORT, chassis
-2	214-0317-00	20000	31689	2	HEAT SINK
	214-1138-00	31690		2	HEAT SINK
-3	210-0627-00			2	RIVET, heat sink
-4	343-0097-00			2	CLAMP, heat sink
-5	352-0062-00			2	HOLDER, heat sink
	- - - - -			-	mounting hardware for each: (not included w/holder)
-6	211-0033-00			2	SCREW, sems, 4-40 x 5/16 inch, PHS
-7	211-0012-00			2	SCREW, 4-40 x 3/8 inch, PHS
-8	210-0004-00			4	LOCKWASHER, internal, #4
-9	214-0368-00			1	SPRING, heat sink
-10	210-0599-00			2	NUT, sleeve
-11	670-0418-02			1	ASSEMBLY, circuit board—B Sweep
	- - - - -			-	assembly includes:
	388-0645-02			1	BOARD, circuit
-12	136-0220-00			24	SOCKET, transistor, 3 pin
-13	136-0235-00			1	SOCKET, transistor, 6 pin
-14	214-0506-00			49	PIN, connector
-15	214-0579-00			7	PIN, test point
-16	214-0565-00			1	FASTENER, pin dress
-17	344-0119-00			6	CLIP, electrical
-18	210-1014-00			1	WASHER, plastic, 0.094 ID x 5/16 inch, PHB
-19	337-0763-00			1	SHIELD
	- - - - -			-	mounting hardware: (not included w/assembly)
-20	211-0116-00			6	SCREW, sems, 4-40 x 5/16 inch, PHB
-21	343-0089-00			7	CLAMP, cable, plastic, large
-22	343-0088-00			2	CLAMP, cable, plastic, small
-23	407-0144-00			1	BRACKET capacitor mounting
	- - - - -			-	mounting hardware: (not included w/bracket)
-24	211-0504-00			4	SCREW, 6-32 x 1/4 inch, PHS
-25	344-0116-00	20000	38689	1	CLIP, capacitor mounting
	344-0140-00	38690		1	CLIP, capacitor mounting
	- - - - -			-	mounting hardware: (not included w/clip)
-26	211-0007-00	20000	38689	1	SCREW, 4-40 x 3/16 inch, PHS
	211-0008-00	38690		1	SCREW, 4-40 x 1/4 inch, PHS
	210-0586-00			1	NUT, keps, 4-40 x 1/4 inch (not shown)
-27	200-0255-00	20000	29519	2	COVER, capacitor, 1 inch diameter x 3 1/32 inches long
	200-0256-00	29520		2	COVER, capacitor, 1 ID x 2 1/32 inch long
-28	200-0257-00	20000	29519	2	COVER, capacitor, 1 inch diameter x 2 17/32 inches long
	200-0532-00	29520		2	COVER, capacitor, 0.990 ID x 1.594 inch long
-29	- - - - -			4	CAPACITOR
	- - - - -			-	mounting hardware for each: (not included w/capacitor)
-30	211-0534-00	20000	29519	2	SCREW, sems, 6-32 x 5/16 inch, PHS
	211-0588-00	29520		2	SCREW, 6-32 x 3/4 inch, HHS
	432-0047-00	X29520		1	BASE, capacitor
-31	386-0252-00			1	PLATE, fiber, small
-32	210-0006-00	20000	29519	2	LOCKWASHER, internal, #6
	210-0407-00	20000	29519	2	NUT, hex., 6-32 x 1/4 inch
	210-0457-00	29520		2	NUT, keps, 6-32 x 5/16 inch

FIG. 4 A & B SWEEPS (cont)

Fig. & Index No.	Tektronix Part No.	Serial/Model No.		Q t y	Description
		Eff	Disc		
4-33	179-0990-01	20000	39319	1	CABLE HARNESS, capacitor chassis
	179-0990-02	39320		1	CABLE HARNESS, capacitor chassis
	- - - - -			-	cable harness includes:
-34	131-0371-00			3	CONNECTOR, single contact, female
-35	179-0994-00	20000	33319X	1	CABLE HARNESS, B Sweep
	- - - - -			-	cable harness includes:
-36	131-0371-00			27	CONNECTOR, single contact, female
-37	179-0995-02			2	CABLE HARNESS, A Sweep
	- - - - -			-	cable harness includes:
-38	131-0371-00			36	CONNECTOR, single contact, female
-39	407-0150-00			1	BRACKET, outer support
	- - - - -			-	bracket includes:
-40	252-0571-00			FT	NEOPRENE, extruded, 0.208 foot
	- - - - -			-	mounting hardware: (not included w/bracket)
	211-0504-00			2	SCREW, 6-32 x 1/4 inch, PHS (not shown)
-41	670-0417-02			1	ASSEMBLY, circuit board—A Sweep
	- - - - -			-	assembly includes:
	388-0644-02			1	BOARD, circuit
-42	136-0220-00			26	SOCKET, transistor, 3 pin
-43	136-0183-00			1	SOCKET, transistor, 3 pin
-44	214-0506-00			47	PIN, connector
-45	214-0579-00			8	PIN, test point
-46	214-0565-00			2	FASTENER, pin press
-47	337-0762-00			1	SHIELD
-48	343-0043-00			1	CLAMP, neon bulb
	- - - - -			-	mounting hardware: (not included w/assembly)
-49	211-0116-00			6	SCREW, sems, 6-32 x 5/16 inch, PHB

FIG. 5 HIGH VOLTAGE ASSEMBLY

Fig. & Index No.	Tektronix Part No.	Serial/Model No.		Q † y	Description
		Eff	Disc		
5-	621-0424-01			1	ASSEMBLY, high voltage
	- - - - -			-	assembly includes:
-1	380-0077-00			1	HOUSING, plastic
-2	179-0988-01			1	CABLE HARNESS
-3	381-0243-00			1	BAR, heat sink
-4	392-0169-00			1	BOARD, high voltage, plastic
	- - - - -			-	board includes:
-5	124-0176-00			1	STRIP, ceramic, 7/16 inch h, w/4 notches
-6	124-0175-00			1	STRIP, ceramic, 7/16 inch h, w/2 notches
	- - - - -			-	mounting hardware: (not included w/board)
-7	211-0036-00			1	SCREW, 4-40 x 1/2 inch, BH plastic
-8	392-0170-00			1	BOARD, high voltage, plastic
	- - - - -			-	board includes:
-9	124-0163-00			8	STRIP, ceramic, 2 notches
-10	124-0164-00			4	STRIP, ceramic, 4 notches
-11	131-0227-00			1	CONNECTOR, terminal stand off
-12	131-0359-00			1	CONNECTOR, terminal feed thru
	358-0176-00			2	BUSHING, plastic (not shown)
-13	210-0966-00			3	WASHER, rubber
-14	- - - - -			1	RESISTOR, variable
	- - - - -			-	mounting hardware: (not included w/resistor)
	210-0046-00			1	LOCKWASHER, internal, 1/4 ID x 0.400 inch OD
-15	210-0583-00			1	NUT, hex., 1/4-32 x 5/16 inch
-16	346-0032-00			4	STRAP, rubber
-17	- - - - -			1	TRANSFORMER
	- - - - -			-	mounting hardware: (not included w/transformer)
-18	211-0552-00			2	SCREW, 6-32 x 2 inches, PHS
-19	210-0869-00			2	WASHER, plastic, 5/32 ID x 3/8 inch OD
-20	358-0231-00			4	BUSHING, rubber
-21	200-0620-00			1	COVER, plastic, high voltage supply
	- - - - -			-	mounting hardware: (not included (w/cover)
-22	211-0552-00	20000	40949	2	SCREW, 6-32 x 2 inches, PHS
	211-0530-00	40950		2	SCREW, 6-32 x 1 3/4 inches, PHS
-23	337-0752-00			1	SHIELD, high voltage supply
	- - - - -			-	mounting hardware: (not included w/shield)
	211-0503-00			3	SCREW, 6-32 x 3/16 inch, PHS (not shown)

FIG. 6 REAR CHASSIS

Fig. & Index No.	Tektronix Part No.	Serial/Model Eff	No. Disc	Qty	Description
6-1	441-0719-00			1	CHASSIS, rear
-2	211-0504-00			2	SCREW, 6-32 x 1/4 inch, PHS
	635-0433-00			1	ASSEMBLY, fan
	- - - - -			-	assembly includes:
-3	369-0025-00			1	IMPELLER, fan, axial
	- - - - -			-	impeller includes:
	213-0126-00			1	SCREW, set, 6-32 x 0.250 inch, HSS
-4	407-0308-01	20000	35091	1	BRACKET, fan motor
	407-0308-02	35092		1	BRACKET, fan motor
-5	147-0027-00			1	MOTOR, fan
	- - - - -			-	mounting hardware: (not included w/motor)
-6	211-0008-00	20000	35091	3	SCREW, 4-40 x 1/4 inch, PHS
	211-0097-00	35092		3	SCREW, 4-40 x 1/4 inch, PHS
	131-0759-00	X35092		1	TERMINAL, lug
-7	210-0054-00			3	LOCKWASHER, #4 split
	- - - - -			-	mounting hardware: (not included w/assembly)
-8	211-0012-00			3	SCREW, 4-40 x 3/8 inch, PHS
-9	210-0851-00			6	WASHER, flat, 0.119 ID x 3/8 inch OD
-10	348-0093-00			3	GROMMET, rubber, shock mount, 0.140 ID x 0.375 inch OD
-11	220-0471-00			3	NUT, stepped, round, 4-40 x 0.217 inch long
	129-0006-00	X30720	33319X	1	POST, stand off (not shown)
	- - - - -			-	mounting hardware: (not included w/post)
	210-0457-00	X30720	33319X	1	NUT, keeps, 6-32 x 5/16 inch
-12	380-0114-00			1	HOUSING, air flow
-13	- - - - -			1	SWITCH, thermostatic
	- - - - -			-	mounting hardware: not included w/switch)
-14	213-0044-00			2	SCREW, thread cutting, 5-32 x 3/16 inch, PHS
-15	- - - - -			3	TRANSISTOR
	- - - - -			-	mounting hardware for each: (not included w/transistor)
-16	211-0510-00			2	SCREW, 6-32 x 3/8 inch, PHS
-17	387-0345-00			1	PLATE, insulator
-19	210-0802-00			2	WASHER, fiber, shouldered, #6
-18	210-0811-00			2	WASHER, flat, 0.150 ID x 5/16 inch OD
-20	210-0202-00			1	LUG, solder, SE #6
-21	210-0006-00			1	LOCKWASHER, internal, #6
-22	210-0407-00			2	NUT, hex., 6-32 x 1/4 inch
-23	- - - - -			1	RESISTOR, variable
	- - - - -			-	mounting hardware: (not included w/resistor)
	210-0223-00			1	LUG, solder, 1/4 ID x 7/16 inch OD, SE
-24	210-0940-00			1	WASHER, flat, 1/4 ID x 3/8 inch OD
-25	210-0583-00			1	NUT, hex., 1/4-32 x 5/16 inch
-26	352-0031-00			1	HOLDER, fuse single
	- - - - -			-	mounting hardware: (not included w/holder)
-27	211-0507-00			1	SCREW, 6-32 x 5/16 inch, PHS
-28	358-0215-00			2	BUSHING, plastic

FIG. 6 REAR CHASSIS (cont)

Fig. & Index No.	Tektronix Part No.	Serial/Model Eff	No. Disc	Q t y	1 2 3 4 5					Description
6-29	214-0210-00			1						ASSEMBLY, solder spool
	- - - - -			-						assembly includes:
	214-0209-00			1						SPOOL, solder
	- - - - -			-						mounting hardware: (not included w/assembly)
	361-0007-00			1						SPACER, plastic, 0.156 inch long
-30	124-0147-00			1						STRIP, ceramic, 7/16 inch h, w/13 notches
	- - - - -			-						strip includes:
	355-0046-00			2						STUD, plastic
	- - - - -			-						mounting hardware: (not included w/strip)
	361-0007-00			2						SPACER, plastic, 0.156 inch long
-31	124-0145-00			2						STRIP, ceramic, 7/16 inch h, w/20 notches
	- - - - -			-						each strip includes:
	355-0046-00			2						STUD, plastic
	- - - - -			-						mounting hardware for each: (not included w/strip)
	361-0007-00			2						SPACER, plastic, 0.156 inch long
-32	210-0202-00			1						LUG, solder, SE #6
	- - - - -			-						mounting hardware: (not included w/lug)
-33	213-0044-00			1						SCREW, thread forming, 5-32 x 3/16 inch, PHS
-34	348-0063-00			5						GROMMET, plastic, 1/2 inch
-35	348-0064-00			2						GROMMET, plastic, 5/8 inch
-36	407-0143-00			1						BRACKET, regulator
	- - - - -			-						mounting hardware: (not included w/bracket)
	211-0504-00			4						SCREW, 6-32 x 1/4 inch, PHS
-37	348-0056-00			1						GROMMET, plastic, 0.354 ID x 0.406 inch OD
-38	- - - - -			2						RESISTOR
	- - - - -			-						mounting hardware for each: (not included w/resistor)
-39	211-0507-00			1						SCREW, 6-32 x 5/16 inch, PHS
-40	210-0478-00			1						NUT, hex., 5/16 x 2 1/32 inch long
	210-0601-00			1						EYELET
	211-0553-00			1						SCREW, 6-32 x 1 1/2 inch, RHS
-41	214-0289-00			2						HEAT SINK, transistor
	- - - - -			-						mounting hardware for each: (not included w/heat sink)
	220-0410-00			1						NUT, keps, 10-32 x 3/8 inch
-42	179-0991-01			1						CABLE HARNESS, regulator bracket
-43	124-0147-00			1						STRIP, ceramic, 7/16 inch h, w/13 notches
	- - - - -			-						strip includes:
	355-0046-00			2						STUD, plastic
	- - - - -			-						mounting hardware: (not included w/strip)
	361-0009-00			2						SPACER, plastic, 0.406 inch long

Mechanical Parts List—Type 453/R453

FIG. 6 REAR CHASSIS (cont)

Fig. & Index No.	Tektronix Part No.	Serial/Model Eff	No. Disc	Q					Description
				t	y	1	2	3	
6-44	124-0119-00			1					STRIP, ceramic, 7/16 inch h, w/2 notches
	- - - - -			-					strip includes:
	355-0046-00			1					STUD, plastic
	- - - - -			-					mounting hardware: (not included w/strip)
	361-0007-00			1					SPACER, plastic, 0.188 inch long
-45	- - - - -			1					TRANSISTOR
	- - - - -			-					mounting hardware: (not included w/transistor)
-46	211-0510-00			2					SCREW, 6-32 x 3/8 inch, PHS
-47	386-0143-00			1					PLATE, mica insulator
-48	210-0983-00			2					WASHER, shouldered
	210-0802-00			2					WASHER, flat, 0.150 ID x 5/16 inch OD
-49	210-0202-00			1					LUG, solder, SE #6
	210-0006-00			1					LOCKWASHER, internal, #6
-50	210-0407-00			2					NUT, hex., 6-32 x 1/4 inch
-51	670-0415-00			1					ASSEMBLY, circuit board—LOW VOLTAGE REGULATOR
	- - - - -			-					assembly includes:
	388-0642-00			1					BOARD, circuit
	- - - - -			-					board includes:
	388-0642-01			1					BOARD, circuit, w/o pins
-52	214-0506-00			21					PIN, connector
-53	136-0183-00			4					SOCKET, transistor, 3 pin
-54	136-0220-00			4					SOCKET, transistor, 3 pin
	- - - - -			-					mounting hardware: (not included w/board)
-55	211-0040-00			3					SCREW, 4-40 x 1/4 inch, BH plastic
-56	214-0781-00	20000	39319X	3					INSULATOR, plastic
-57	343-0088-00			6					CLAMP, cable, small
-58	179-0987-02			1					CABLE HARNESS, low voltage regulator
-59	407-0146-00			1					BRACKET, upper, vertical preamp board
-60	407-0147-00			1					BRACKET, upper, vertical preamp board
-61	670-0416-00			1					ASSEMBLY, circuit board—VERT OUTPUT AMP
	- - - - -			-					assembly includes:
	388-0643-01			1					BOARD, circuit
-62	214-0506-00			6					PIN, connector
-63	136-0220-00			6					SOCKET, transistor, 3 pin
-64	344-0119-00			4					CLIP, electrical
	- - - - -			-					mounting hardware: (not included w/assembly)
-65	211-0116-00			4					SCREW, 4-40 x 5/16 inch, PHS w/lockwasher
-66	- - - - -			1					TRANSFORMER
	- - - - -			-					mounting hardware: (not included w/transformer)
-67	212-0576-00	20000	25609	4					SCREW, 10-32 x 1 3/8 inches, HHS
	212-0553-00	25610	39319X	4					SCREW, 10-32 x 1 1/2 inches, RHS
-68	220-0410-00	20000	39319X	4					NUT, keeps, 10-32 x 3/8 inch
-69	407-0323-00	20000	39319X	1					BRACKET, transformer
	- - - - -			-					mounting hardware: (not included w/bracket)
-70	212-0004-00	20000	39319X	4					SCREW, 8-32 x 5/16 inch, PHS

FIG. 6 REAR CHASSIS (cont)

Fig. & Index No.	Tektronix Part No.	Serial/Model Eff	No. Disc	Q					Description	
				t	y	1	2	3		4
6-71	352-0031-00			2						HOLDER, fuse, single
	- - - - -			-						mounting hardware for each: (not included w/holder)
-72	211-0538-00	20000	33319X	2						SCREW, 6-32 x 5/16 inch, 100° csk, FHS
-73	210-0006-00	20000	33319	2						LOCKWASHER, internal, #6
	210-0054-00	33320		2						LOCKWASHER, #4 split
-74	210-0407-00	20000	33319	2						NUT, hex., 6-32 x 1/4 inch
	210-0406-00	33320		2						NUT, hex., 4-40 x 3/16 inch
-75	670-0414-04			1						ASSEMBLY, circuit board—Z AXIS
	- - - - -			-						assembly includes:
	388-0641-02			1						BOARD, circuit
-76	214-0506-00			20						PIN, connector
-77	214-0579-00			3						PIN, test point
-78	136-0183-00			4						SOCKET, transistor, 3 pin
-79	136-0220-00			4						SOCKET, transistor, 3 pin
	- - - - -			-						mounting hardware: (not included w/socket)
-80	211-0116-00			3						SCREW, sems, 4-40 x 5/16 inch, PHB
-81	179-0995-02			1						CABLE HARNESS, A sweep
	- - - - -			-						cable harness includes:
	131-0371-00			37						CONNECTOR, single contact, female
-82	386-0202-01			1						PLATE, center bulk head
-83	348-0064-00			2						GROMMET, plastic, 5/8 inch
-84	348-0056-00			2						GROMMET, plastic, 0.354 ID x 0.406 inch OD
-85	348-0055-00			1						GROMMET, plastic, 1/4 inch
-86	131-0181-00			1						CONNECTOR, terminal, standoff
	- - - - -			-						mounting hardware: (not included w/connector)
	358-0136-00			1						BUSHING, plastic
-87	343-0002-00			1						CLAMP, cable, 3/16 inch
	- - - - -			-						mounting hardware: (not included w/clamp)
-88	211-0507-00			1						SCREW, 6-32 x 5/16 inch, PHS
-89	210-0863-00			1						WASHER, "D" type, 0.191 ID x 33/64 x 33/64 inch long
-90	210-0457-00			1						NUT, keps, 6-32 x 5/16 inch
-91	129-0069-00			3						POST, terminal, tie off
	- - - - -			-						mounting hardware for each: (not included w/post)
	361-0007-00			1						SPACER, plastic, 0.188 inch long
-92	210-0201-00			1						LUG, solder, SE #4
	- - - - -			-						mounting hardware: (not included w/lug)
	213-0044-00			1						SCREW, thread forming, 5-32 x 3/16 inch, PHS
-93	214-0317-00			2						HEAT SINK
-94	352-0062-00			2						HOLDER, heat sink
	- - - - -			-						mounting hardware for each: (not included w/holder)
	211-0033-00			2						SCREW, sems, 4-40 x 5/16 inch, PHS
	211-0012-00			2						SCREW, 4-40 x 3/8 inch, PHS
	210-0004-00			4						LOCKWASHER, internal, #4
	210-0406-00			4						NUT, hex., 4-40 x 3/16 inch

Mechanical Parts List—Type 453/R453

FIG. 6 REAR CHASSIS (cont)

Fig. & Index No.	Tektronix Part No.	Serial/Model Eff	No. Disc	Q					Description	
				†	Y	1	2	3		4
6-95	343-0097-00			2						CLAMP, heat sink
-96	214-0368-00			4						SPRING, heat sink
	210-0627-00			2						RIVET, heat sink (not shown)
-97	210-0599-00			4						NUT, sleeve
-98	202-0142-01			1						BOX, high voltage
	- - - - -			-						mounting hardware: (not included w/box)
-99	210-0504-00			6						SCREW, 6-32 x 1/4 inch, PHS
-100	343-0013-00			3						CLAMP, cable, 3/8 inch
	- - - - -			-						mounting hardware for each: (not included w/clamp)
-101	211-0507-00			1						SCREW, 6-32 x 5/16 inch, PHS
-102	210-0863-00			1						WASHER, "D" type, 0.191 x 33/64 x 33/64 inch long
-103	210-0457-00			1						NUT, keps, 6-32 x 5/16 inch
-104	- - - - -			1						CAPACITOR
	- - - - -			-						mounting hardware: (not included w/capacitor)
	211-0504-00			2						SCREW, 6-32 x 1/4 inch, PHS
	210-0006-00			2						LOCKWASHER, internal, #6
	210-0407-00			2						NUT, hex., 6-32 x 1/4 inch
-105	407-0145-00	20000	31029	1						BRACKET, delay line
	- - - - -			-						bracket includes:
-106	358-0282-00			1						BUSHING, insulating
	407-0480-00	31030		1						BRACKET, delay line
	- - - - -			-						mounting hardware: (not included w/bracket)
	211-0097-00			3						SCREW, 4-40 x 5/16 inch
	210-0851-00			1						WASHER, flat, 0.119 ID x 3/8 inch OD
	210-0935-00			1						WASHER, fiber, 0.140 ID x 0.375 inch OD
	211-0507-00			1						SCREW, 6-32 x 5/16 inch, PHS
	213-0049-00			1						SCREW, 6-32 x 5/16 inch, HHS
-107	348-0055-00	2000	31029X	2						GROMMET, plastic, 1/4 inch

FIG. 6 REAR CHASSIS (cont)

Fig. & Index No.	Tektronix Part No.	Serial/Model Eff	No. Disc	Q					Description	
				t	y	1	2	3		4
6-	119-0168-01			1						ASSEMBLY, delay line
	- - - - -			-						assembly includes:
	119-0029-00	20000	31029	1						ASSEMBLY, delay line
	119-0168-00	31030		1						ASSEMBLY, delay line
	- - - - -			-						assembly includes:
-108	380-0049-00			1						HOUSING, delay line
-109	200-0482-00			1						COVER, delay line
	- - - - -			-						mounting hardware: (not included w/cover)
-110	211-0513-00			4						SCREW, 6-32 x 5/8 inch, PHS
	210-0407-00			4						NUT, hex., 6-32 x 1/4 inch
-111	131-0272-00			1						CONNECTOR, left hand mounting
	- - - - -			-						mounting hardware: (not included w/connector)
	211-0097-00			1						SCREW, 4-40 x 5/16 inch, PHS
	210-0004-00			1						LOCKWASHER, internal, #4
-112	210-0406-00			1						NUT, hex., 4-40 x 3/16 inch
-113	131-0271-00			1						CONNECTOR, right hand mounting
	- - - - -			-						mounting hardware: (not included w/connector)
	211-0097-00			1						SCREW, 4-40 x 5/16 inch, PHS
	210-0004-00			1						LOCKWASHER, internal, #4
	210-0406-00			1						NUT, hex., 4-40 x 3/16 inch
-114	131-0157-00			2						CONNECTOR, terminal standoff
	131-0158-00			2						CONNECTOR, terminal, feed-thru
-115	211-0517-00			1						SCREW, 6-32 x 1 inch, PHS
	210-0407-00			1						NUT, hex., 6-32 x 1/4 inch
	- - - - -			-						mounting hardware: (not included w/assembly)
	210-0457-00	20000	31029	1						NUT, keps, 6-32 x 5/16 inch
	211-0504-00	31030		1						SCREW, 6-32 x 1/4 inch, PHS
	211-0578-00	31030		3						SCREW, 6-32 x 3/16 inch, PHS
	343-0111-00	31030		3						CLAMP, cable, plastic, large
	210-0863-00	31030		3						WASHER, D shape, 0.191 ID x 33/64 x 33/64 inch long
	210-0204-00	31030		1						LUG, solder, DE #6

FIG. 7 CABINET & FRAME

Fig. & Index No.	Tektronix Part No.	Serial/Model Eff	No. Disc	Q t y	1 2 3 4 5					Description
					1	2	3	4	5	
7-1	200-0633-02			1						ASSEMBLY, front cover (type 453 only)
-2	214-0531-01			2						assembly includes: LATCH ASSEMBLY
-3	348-0013-00			4						FOOT, rubber
-4	214-0755-00			2						PIN, hinge, plastic
-5	252-0571-00			FT						EXTENSION, neoprene, 3 feet
-6	348-0091-00			1						CUSHION, cover, bottom
-7	200-0710-00			1						DOOR, accessory storage
-8	352-0093-00			1						door includes: HOLDER, fuse storage
-9	204-0282-00			1						BODY, latch
-10	214-0787-00			1						STEM, latch
-11	348-0118-00			1						CUSHION, cover
-12	386-1177-00			1						PLATE, cabinet, bottom
-13	348-0080-01			4						FOOT, rubber
	210-0005-00			1						LOCKWASHER, external, #6
-14	211-0504-00			1						SCREW, 6-32 x 1/4 inch, PHS
-15	386-1178-00			1						PLATE, cabinet, top
-16	367-0058-00			1						HANDLE, carrying
-17	211-0512-00			4						mounting hardware for each: (not included w/handle) SCREW, 6-32 x 1/2 inch, 100° csk, FHS
-18	200-0602-00			2						COVER, handle
-19	214-0516-00			2						SPRING, handle index
-20	214-0513-00	20000	45659	2						INDEX, handle ring
	214-0513-04	45660		2						INDEX, handle ring
-21	214-0578-00	20000	45659	2						HUB, index handle
	214-0578-03	45660		2						HUB, index handle
				-						mounting hardware for each: (not included w/hub)
-22	214-0910-01			2						SCREW, cabinet latch
	354-0175-00			2						RING, retaining
-23	426-0260-00			2						FRAME, rail
				-						mounting hardware for each: (not included w/frame)
-24	212-0560-00	20000	23179	4						SCREW, 10-32 x 5/16 inch, 100° csk, FHS
	212-0506-00	23180		4						SCREW, 10-32 x 3/8 inch, 100° csk, FHS
-25	426-0317-01			1						FRAME, cabinet, rear
-26	348-0078-00	20000	29729X	4						FOOT, body & cord holder
	348-0078-01	20000	29729X	4						FOOT, body & cord holder
-27	348-0079-00	20000	22989	4						FOOT, cap
	348-0079-01	22990		4						FOOT, cap
	348-0191-00	X29730		4						FOOT, cabinet, plastic
	348-0190-00	X29730		4						FOOT, cabinet, plastic
-28	212-0082-00	20000	22989	4						SCREW, 8-32 x 1 1/4 inches, PHS
	212-0001-00	22990		4						SCREW, 8-32 x 1/4 inch, PHS
	129-0146-00	X22990		4						POST, metal, 3/4 inch long (not shown)
-29	129-0020-00			1						POST, binding
				-						post includes: CAP, binding post
	200-0072-00			1						STEM, adapter
	355-0503-00			1						STEM, adapter
				-						mounting hardware: (not included w/post)
-30	220-0410-00			1						NUT, keps, 10-32 x 3/8 inch

FIG. 7 CABINET & FRAME

Fig. & Index No.	Tektronix Part No.	Serial/Model No. Eff	No. Disc	Q					Description	
				t	y	1	2	3		4
7-31	129-0064-00			1						POST, binding
	- - - - -			-						mounting hardware: (not included w/post)
-32	358-0181-00			1						BUSHING, plastic
	210-0203-00			1						LUG, solder, SE #6 long
-33	210-0457-00			1						NUT, keps, 6-32 x 5/16 inch
-34	346-0043-00			1						STRAP, ground
-35	386-1187-00			1						PLATE, rear panel
	- - - - -			-						mounting hardware: (not included w/plate)
-36	211-0565-00			4						SCREW, 6-32 x 1/4 inch, THS
-37	386-1122-00			1						PLATE
	- - - - -			-						mounting hardware: (not included w/plate)
-38	211-0504-00			2						SCREW, 6-32 x 1/4 inch, PHS
-39	358-0323-00			1						FASTENER, power cord
-40	161-0033-00			1						CORD, power, 3 conductor
	343-0170-00	X29520		1						RETAINER, cable to cable (not shown)
-41	204-0279-00			1						BODY, line voltage selector
	- - - - -			-						mounting hardware: (not included w/body)
	210-0006-00			2						LOCKWASHER, internal, #6 (not shown)
	210-0407-00			2						NUT, hex., 6-32 x 1/4 inch (not shown)
-42	200-0704-00			1						COVER, line voltage selector
	- - - - -			-						cover includes:
-43	352-0102-00			2						HOLDER, fuse, plastic
	- - - - -			-						mounting hardware for each: (not included w/holder)
-44	213-0035-00			2						SCREW, thread cutting, 4-40 x 1/4 inch (not shown)
-45	378-0036-01			1						FILTER, air
-46	380-0082-00			1						HOUSING, fan filter
	- - - - -			-						mounting hardware: (not included w/housing)
-47	213-0107-00			4						SCREW, thread forming, 4-40 x 1/4 inch, FHS
-48	179-1140-00			1						CABLE HARNESS, w/connector, line voltage selector
-49	343-0004-00			1						CLAMP, cable, plastic, 5/16 inch diameter
	- - - - -			-						mounting hardware: (not included w/clamp)
	211-0510-00			1						SCREW, 6-32 x 3/8 inch, PHS
	210-0863-00			1						WASHER, "D" shape, 0.191 ID x 33/64 x 33/64 inch long
-50	210-0457-00			1						NUT, keps, 6-32 x 5/16 inch

Mechanical Parts List—Type 453/R453

FIG. 8 TYPE R453

Fig. & Index No.	Tektronix Part No.	Serial/Model Eff	No. Disc	Q					Description	
				y	1	2	3	4		5
8-1	- - - - -			1					1	TYPE 453 OSCILLOSCOPE
-2	426-0297-00			1					1	FRAME, front
-3	386-1059-00			1					1	PLATE, shield
-4	211-0503-00			-					-	mounting hardware: (not included w/plate)
				3					3	SCREW, 6-32 x 3/16 inch, PHS
-5	386-1063-00			1					1	PLATE, front frame backing, top
-6	212-0002-00			-					-	mounting hardware: (not included w/plate)
				1					1	SCREW, 8-32 x 1/4 inch, 100° csk, FHS
-7	386-1062-00			1					1	PLATE, front frame backing, bottom
-8	212-0002-00			-					-	mounting hardware: (not included w/plate)
				1					1	SCREW, 8-32 x 1/4 inch, 100° csk, FHS
-9	200-0668-00			1					1	COVER, bottom
-10	212-0001-00			-					-	mounting hardware: (not included w/cover)
	211-0502-00			2					2	SCREW, 8-32 x 1/4 inch, PHS
				1					1	SCREW, 6-32 x 3/16 inch, 100° csk, FHS (not shown)
-11	200-0667-00			1					1	COVER, top
-12	212-0001-00			-					-	mounting hardware: (not included w/cover)
-13	211-0502-00			2					2	SCREW, 8-32 x 1/4 inch, PHS
				1					1	SCREW, 6-32 x 3/16 inch, 100° csk, FHS
-14	386-1064-00			1					1	PLATE, side
-15	212-0043-00			-					-	mounting hardware: (not included w/plate)
-16	212-0040-00			4					4	SCREW, 8-32 x 1/2 inch, 100° csk, FHS
-17	212-0023-00			1					1	SCREW, 8-32 x 3/8 inch, 100° csk, FHS
-18	210-0458-00			1					1	SCREW, 8-32 x 3/8 inch, PHS
				6					6	NUT, keps, 8-32 x 1 1/32 inch
-19	351-0104-00			1					1	GUIDE, w/mounting hardware (pair)
-20	426-0291-02			1					1	FRAME, support, right
-21	212-0040-00			-					-	mounting hardware: (not included w/frame)
				4					4	SCREW, 8-32 x 3/8 inch, 100° csk, FHS
-22	426-0291-01			1					1	FRAME, support, left
-23	212-0040-00			-					-	mounting hardware: (not included w/frame)
				4					4	SCREW, 8-32 x 3/8 inch, 100° csk, FHS

FIG. 8 TYPE R453 (cont)

Fig. & Index No.	Tektronix Part No.	Serial/Model Eff	No. Disc	Q					Description	
				t	y	1	2	3		4
8-24	213-0129-00			4						SCREW, 1/4-20 x 3/4 inch, HSS
-25	361-0120-00			2						SPACER, stepped
-26	386-1061-00			1						PLATE, hinge
	- - - - -			-						mounting hardware: (not included w/plate)
-27	211-0503-00			3						SCREW, 6-32 x 3/16 inch, PHS
-28	358-0215-00			1						BUSHING, black plastic
-29	211-0507-00			1						SCREW, 6-32 x 5/16 inch, PHS
-30	134-0067-00			4						PLUG, gray plastic
-31	386-1261-00			1						PLATE, rear
-32	212-0010-00			4						SCREW, 8-32 x 5/8 inch, PHS
-33	210-0808-00			1						WASHER, centering
	- - - - -			-						mounting hardware: (not included w/washer)
-34	211-0507-00			1						SCREW, 6-32 x 5/16 inch, PHS
-35	210-0457-00			1						NUT, keps, 6-32 x 5/16 inch
-36	386-1066-00			2						PLATE, pin retaining
	- - - - -			-						mounting hardware for each: (not included w/plate)
-37	212-0008-00			2						SCREW, 8-32 x 1/2 inch, PHS
-38	367-0022-00			2						HANDLE
	- - - - -			-						mounting hardware for each: (not included w/handle)
-39	213-0090-00			2						SCREW, 10-32 x 1/4 inch, HSS

MANUAL CHANGE INFORMATION

At Tektronix, we continually strive to keep up with latest electronic developments by adding circuit and component improvements to our instruments as soon as they are developed and tested.

Sometimes, due to printing and shipping requirements, we can't get these changes immediately into printed manuals. Hence, your manual may contain new change information on following pages.

A single change may affect several sections. Since the change information sheets are carried in the manual until all changes are permanently entered, some duplication may occur. If no such change pages appear following this page, your manual is correct as printed.

SERVICE NOTE

Because of the universal parts procurement problem, some electrical parts in your instrument may be different from those described in the Replaceable Electrical Parts List. The parts used will in no way alter or compromise the performance or reliability of this instrument. They are installed when necessary to ensure prompt delivery to the customer. Order replacement parts from the Replaceable Electrical Parts List.

CALIBRATION TEST EQUIPMENT REPLACEMENT

Calibration Test Equipment Chart

This chart compares TM 500 product performance to that of older Tektronix equipment. Only those characteristics where significant specification differences occur, are listed. In some cases the new instrument may not be a total functional replacement. Additional support instrumentation may be needed or a change in calibration procedure may be necessary.

Comparison of Main Characteristics

DM 501 replaces 7D13		
PG 501 replaces 107 108	PG 501 - Risetime less than 3.5 ns into 50 Ω . PG 501 - 5 V output pulse; 3.5 ns Risetime	107 - Risetime less than 3.0 ns into 50 Ω . 108 - 10 V output pulse 1 ns Risetime
PG 502 replaces 107 108 111	PG 502 - 5 V output PG 502 - Risetime less than 1 ns; 10 ns Pretrigger pulse delay	108 - 10 V output 111 - Risetime 0.5 ns; 30 to 250 ns Pretrigger pulse delay
PG 508 replaces 114 115 2101	Performance of replacement equipment is the same or better than equipment being replaced.	
PG 506 replaces 106 067-0502-01	PG 506 - Positive-going trigger output signal at least 1 V; High Amplitude output, 60 V. PG 506 - Does not have chopped feature.	106 - Positive and Negative-going trigger output signal, 50 ns and 1 V; High Amplitude output, 100 V. 0502-01 - Comparator output can be alternately chopped to a reference voltage.
SG 503 replaces 190, 190A, 190B 191 067-0532-01	SG 503 - Amplitude range 5 mV to 5.5 V p-p. SG 503 - Frequency range 250 kHz to 250 MHz.	190B - Amplitude range 40 mV to 10 V p-p. 0532-01 - Frequency range 65 MHz to 500 MHz.
SG 504 replaces 067-0532-01 067-0650-00	SG 504 - Frequency range 245 MHz to 1050 MHz.	0532-01 - Frequency range 65 MHz to 500 MHz.
TG 501 replaces 180, 180A 181 184 2901	TG 501 - Trigger output-slaved to marker output from 5 sec through 100 ns. One time-mark can be generated at a time. TG 501 - Trigger output-slaved to marker output from 5 sec through 100 ns. One time-mark can be generated at a time. TG 501 - Trigger output-slaved to marker output from 5 sec through 100 ns. One time-mark can be generated at a time.	180A - Trigger pulses 1, 10, 100 Hz; 1, 10, and 100 kHz. Multiple time-marks can be generated simultaneously. 181 - Multiple time-marks 184 - Separate trigger pulses of 1 and 0.1 sec; 10, 1, and 0.1 ms; 10 and 1 μ s. 2901 - Separate trigger pulses, from 5 sec to 0.1 μ s. Multiple time-marks can be generated simultaneously.

NOTE: All TM 500 generator outputs are short-proof. All TM 500 plug-in instruments require TM 500-Series Power Module.



TEKTRONIX®

*committed to
technical excellence*

MANUAL CHANGE INFORMATION

PRODUCT GENERAL

CHANGE REFERENCE S23,351

DATE 6-10-76 REV. _____

CHANGE:

DESCRIPTION

This applies to all instruments with detachable cord.

WARNING

To avoid electrical shock or equipment damage, be sure to replace the cord set only with another of the same polarity.

Power Cord Conductor Identification

Conductor	Color	Alternate Color
Ungrounded (Line)	Brown	Black
Grounded (Neutral)	Blue	White
Grounding (Earthing)	Green-Yellow	Green-Yellow