

1/10 100

FANUC AC SPINDLE SERVO UNIT

MAINTENANCE MANUAL

Service Manual
File
in
...

This manual describes the following products:

Name of products	Abbreviation	
FANUC AC SPINDLE SERVO UNIT MODEL 1	MODEL 1	AC SPINDLE SERVO UNIT series
FANUC AC SPINDLE SERVO UNIT MODEL 2	MODEL 2	
FANUC AC SPINDLE SERVO UNIT MODEL 3	MODEL 3	
FANUC AC SPINDLE SERVO UNIT MODEL 6	MODEL 6	
FANUC AC SPINDLE SERVO UNIT MODEL 8	MODEL 8	
FANUC AC SPINDLE SERVO UNIT MODEL 12	MODEL 12	
FANUC AC SPINDLE SERVO UNIT MODEL 15	MODEL 15	
FANUC AC SPINDLE SERVO UNIT MODEL 18	MODEL 18	
FANUC AC SPINDLE SERVO UNIT MODEL 22	MODEL 22	
FANUC AC SPINDLE SERVO UNIT MODEL 30	MODEL 30	
FANUC AC SPINDLE SERVO UNIT MODEL 40	MODEL 40	
FANUC AC SPINDLE SERVO UNIT MODEL 1S	MODEL 1S	
FANUC AC SPINDLE SERVO UNIT MODEL 1.5S	MODEL 1.5S	
FANUC AC SPINDLE SERVO UNIT MODEL 2S	MODEL 2S	
FANUC AC SPINDLE SERVO UNIT MODEL 3S	MODEL 3S	
FANUC AC SPINDLE SERVO UNIT MODEL 2H	MODEL 2H	
FANUC AC SPINDLE SERVO UNIT MODEL 2VH	MODEL 2VH	

In this manual we have tried as much as possible to describe all the various matters.

However, we cannot describe all the matters which must not be done, or which cannot be done, because there are so many possibilities.

Therefore, matters which are not especially described as possible in this manual should be regarded as "impossible".

CONTENTS

I. AC SPINDLE SERVO UNIT (200/220V AC INPUT)	
1. OUTLINE	3
1.1 Structure	3
2. DAILY MAINTENANCE AND MAINTENANCE TOOLS	7
2.1 AC Spindle Motor	7
2.2 AC Spindle Servo Unit	7
2.3 Maintenance Tools	7
2.3.1 Tools used for adjustment	7
2.4 Major Maintenance Parts	8
3. TROUBLESHOOTING	9
3.1 Power Voltage Check	9
3.2 Power On Indicator Lamp OIL does not Light	11
3.3 Alarm Lamp Lights on PCB	12
3.4 Motor does not Rotate, or Motor does not Rotate the Specified Revolutions	27
3.5 Vibrations or noises are Noticeable during Rotation	27
3.6 Abnormal Noise is Produced from Motor during Deceleration	27
3.7 Speed Overshooting or Hunting Occurs	28
3.8 Cutting Power is Low	28
3.9 Orientation is not Correct	28
3.10 Acceleration/Deceleration Time is Long	29
4. INSTALLATION	30
4.1 Installation Procedure	30
4.2 Power Connection	30
4.2.1 Power voltage and capacity check	30
4.2.2 Protective earth connection	31
4.2.3 Power connection	31
4.3 AC Spindle Motor Connection	31
4.4 Signal Cable Connection	31
5. SETTING AND ADJUSTMENT	32
5.1 Setting of Unit and PCB	32
5.2 Setting and Adjustment of Spindle Orientation Control Circuit Option	37
6. EXCHANGE METHODS OF FUSES AND PCB	38
6.1 Exchange of Fuses	38
6.2 Exchange of PCB	40
6.2.1 MODEL 1/2/small MODEL 3	40
6.2.2 MODEL 3 - 40	42
6.3 Exchange of Spindle Orientation Control Circuit PCB	43
6.3.1 MODEL 1/2/small MODEL 3	43
6.3.2 MODEL 3 - 40	44
7. SPINDLE ORIENTATION CONTROL CIRCUIT	45
7.1 Configuration	45
7.2 Adjustment of Position Coder System Spindle Orientation Control Circuit	46
7.2.1 Setting and adjustment of spindle orientation control circuit in 2-step spindle speed change	46

7.2.2	Setting and adjustment for spindle orientation control circuit 3 or 4 step spindle speed change	52
7.3	Adjustment of Magnetic Sensor Spindle Orientation Control Circuit	55
7.3.1	Mounting method of magnetizing element and magnetic sensor ...	55
7.3.2	Setting and adjustment of spindle orientation control circuit in 2-step speed change spindle for standard type	56
7.3.3	Setting and adjustment of spindle orientation control circuit in 2-step spindle speed for high speed	63
7.3.4	Setting and adjustment of spindle orientation control circuit in case of 3-step spindle speed change	70
7.3.5	Method of checking the spindle position loop gain	74
II.	AC SPINDLE SERVO UNIT (380/415V AC INPUT TYPE)	
1.	OUTLINE	77
1.1	Configuration	77
2.	DAILY MAINTENANCE AND MAINTENANCE TOOL	77
3.	INSTALLATION	77
4.	SETTING AND ADJUSTMENT	78
4.1	Setting on PCB	78
5.	TROUBLESHOOTING AND COUNTERMEASURE	81
III.	DIGITAL AC SPINDLE SERVO UNIT (MODEL 3 - 22)	
1.	OUTLINE	85
1.1	Configuration	85
2.	DAILY MAINTENANCE AND INSTRUMENTS FOR MAINTENANCE	86
3.	INSTALLATION	86
4.	SETTING	87
4.1	Method of Parameter Setting	87
4.2	Number and Contents of Parameter	88
4.3	Rank at Setting	96
5.	TROUBLESHOOTING AND COUNTERMEASURE	98
6.	METHOD OF REPLACEMENT OF FUSE AND PRINTED CIRCUIT BOARD	100
7.	SPINDLE ORIENTATION CONTROL CIRCUIT	100
IV.	DIGITAL AC SPINDLE SERVO UNIT (MODEL 1S, 1.5S, 2S, 3S, 2H, 2VH)	
1.	OUTLINE	103
1.1	Configuration	103
2.	DAILY MAINTENANCE AND MAINTENANCE TOOL	104
3.	INSTALLATION	104

4.	SETTING	105
4.1	Parameter Setting Method	105
4.2	Number and Content of Parameter	106
4.3	Setting Rank	113
4.4	Setting Method of Short Pin	114
4.5	Adjustment Method of Variable Resistor	115
5.	TROUBLESHOOTING AND COUNTERMEASURE	116
6.	REPLACEMENT METHOD OF FUSE AND PCB	117
7.	SPINDLE ORIENTATION CONTROL CIRCUIT	117

APPENDIXES

APPENDIX 1	CONNECTION DIAGRAMS	121
APPENDIX 2	CABLE ENTRANCE DIAGRAM	132
APPENDIX 3	CABLE SPECIFICATIONS	134
APPENDIX 4	MAIN CIRCUIT DIAGRAM	139
4.1	Main Circuit	139
APPENDIX 5	MOUNTING LAYOUT OF SPINDLE SERVO UNIT PARTS (OTHER THAN PCB)	142
APPENDIX 6	MOUNTING LAYOUT OF SPINDLE CONTROL CIRCUIT PCB	151
APPENDIX 7	MAJOR PARTS LIST	158
APPENDIX 8	PCB ADJUSTMENTS	161
APPENDIX 9	CHECKING METHOD FOR PCB	168
1.	Check Terminal	168
2.	Check Terminal Data Confirmation Method	176
3.	Digital AC Spindle (MODEL 3 to 22)	180
4.	Digital AC Spindle (MODEL 1S, 1.5S, 2S, 3S, 2H, 2VH)	184
APPENDIX 10	MAGNETIC SENSOR SIGNALS CHECKING METHOD	187
1.	Application	187
2.	Check Procedure	187
APPENDIX 11	PARAMETER LIST FOR DIGITAL AC SPINDLE SERVO UNIT	190

**I. AC SPINDLE SERVO UNIT
(200/220 V AC INPUT)**

1. OUTLINE

This manual describes maintenance of AC SPINDLE SERVO UNIT and its options.
 (For applicable units of this manual, see Table 1.1 (a),(b))

1.1 Structure

The AC SPINDLE SERVO UNIT consists of the following units and parts.

- | | | |
|--|----------|--------------------------------|
| (1) Spindle control unit | (basic) | { ① Unit
{ ② PCB
{ ③ ROM |
| (2) Resistance unit *1 | (basic) | |
| (3) Fuses (for spare) | (basic) | |
| (4) Connectors (for connections) | (basic) | |
| (5) DA converter | (option) | |
| (6) Power transformer | (option) | |
| (7) Spindle orientation control circuit | (option) | |
| (8) Speed gain selection control circuit | (option) | |
| (9) Spindle selection control circuit | (option) | |
| (10) Unit cover *2 | (option) | |
| (11) Unit adapter *2 | (option) | |
| (12) Fan unit *3 | (option) | |

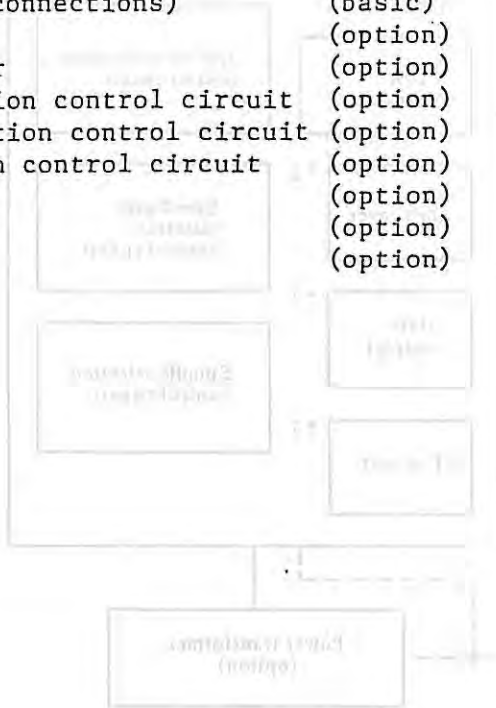

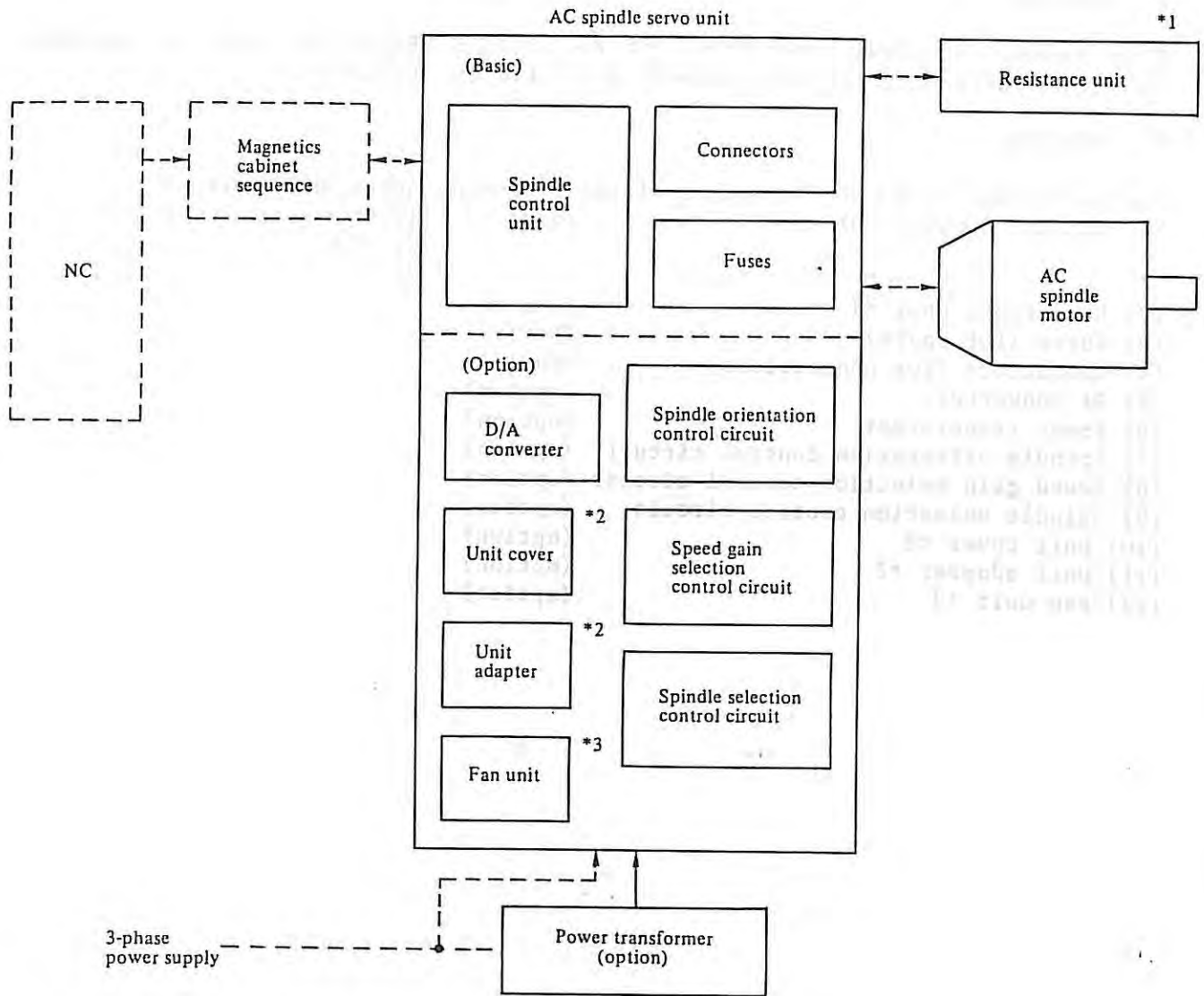

*1: The resistance unit is employed for MODEL 1/2/small type 3 (A06B-6052-H001, H002, H003) only.

*2: These options are used for MODEL 8 and 12 (A06B-6044-H108, H112) only.

*3: This fan unit is used for MODEL 30 and 40 (A06B-6044-H130, H140) only.

Fig 1.1 Block diagram

Table 1.1 (a) Major components (basic)

MODEL of AC spindle servo unit	Specification number		Unit number		PCB	ROM		Applicable AC spindle motor specification drawing number
	External radiation type	Standard type	External radiation type	Standard type		Specified number	Type	
MODEL 1	A06B-6052-H001		A06B-6052-C001		A16B-1100-0080 A16B-1100-0090	A06B-6052-C501	J21	A06B-1001-B100,-B200
MODEL 2	A06B-6052-H002		A06B-6052-C002		A16B-1100-0080 A16B-1100-0091	A06B-6052-C502	J22	A06B-1002-B100,-B200
Small type MODEL 3	A06B-6052-H003		A06B-6052-C003		A16B-1100-0080 A16B-1100-0092	A06B-6052-C503	J23	A06B-0704-B001,-B002 A06B-1003-B100,-B200
MODEL 3	A06B-6044-H203	A06B-6044-H007 A06B-6044-H103	A06B-6044-C203	A06B-6044-C008 A06B-6044-C103	A20B-0009-0530 A20B-1000-0690	A06B-6044-C507/J10	J10	
MODEL 6	A06B-6044-H206	A06B-6044-H008 A06B-6044-H106	A06B-6044-C206	A06B-6044-C008 A06B-6044-C106	A20B-0009-0531 A20B-1000-0691	A06B-6044-C508/J11	J11	A06B-0707-B001,-B002 A06B-1006-B100,-B200
High-speed MODEL 6	A06B-6044-H260	A06B-6044-H009 A06B-6044-B160	A06B-6044-C208	A06B-6044-C009 A06B-6044-C108	A20B-0009-0532 A20B-1000-0692	A06B-6044-C521	J74	A06B-1006-B903,-B904
MODEL 8	A06B-6044-H208	A06B-6044-H010 A06B-6044-H108				A06B-6044-C509	J02	A06B-0706-B001,-B002 A06B-1008-B100,-B200
MODEL 12	A06B-6044-H212	A06B-6044-H112	A06B-6044-C212	A06B-6044-C010 A06B-6044-C112	A20B-0009-0533 A20B-1000-0693	A06B-6044-C510	J03	A06B-0705-B001,-B002 A06B-1012-B100,-B200
MODEL 15	A06B-6044-H023	A06B-6044-H011	A06B-6044-C017	A06B-6044-C011	A20B-0009-0534	A06B-6044-C511	J04	A06B-0708-B001,-B002 A06B-1015-B100,-B200
MODEL 18	A06B-6044-H034	A06B-6044-H016	A06B-6044-C019	A06B-6044-C012	A20B-0009-0538	A06B-6044-C516	J05	A06B-0709-B001,-B002
MODEL 22	A06B-6044-H027	A06B-6044-H017	A06B-6044-C018	A06B-6044-C013	A20B-1000-0539	A06B-6044-C517	J06	A06B-0710-B001,-B002
MODEL 30	A06B-6044-H130		A06B-6044-C130		A20B-1000-0700	A06B-6044-C536	J07	A06B-1030-B100,-B200
MODEL 40	A06B-6044-H140		A06B-6044-C140		A20B-1000-0701	A06B-6044-C529	J08	A06B-1040-B100,-B200

- Note 1) Mounting parts of PCB A20B-0009-0530 - 0539 are identical to each other, except for ROM, but their setting and adjustment differ from each other.
- Note 2) Mounting parts of PCB A20B-1000-0690 - 0693 are identical to each other, except for ROM, but their setting and adjustment differ from each other.
- Note 3) Mounting parts of PCB A20B-1000-0700 - 0701 are identical to each other, except for ROM, but their setting and adjustment differ from each other.
- Note 4) Mounting parts of PCB A16B-1100-0090 - 0092 are identical to each other, but their setting and adjustment differ each other.
- Note 5) The ROM mounting position shows MD25 (MH28 in case of A16B-1100-0080)
(See appendix 6 PCB parts wiring diagram)
- Note 6) The ROM type is indicated as shown in the right figure.

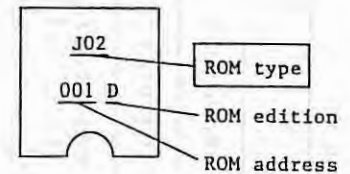

Table 1.1 (b) Order specification

Name		Specification No.	PCB No.
D/A converter (BCD)		A06B-6041-J031	
D/A converter (BINARY)		A06B-6041-J032	
MODEL 1/2/small type 3	Orientation AS (Position coder type, 2-stage speed change gear spindle)	A06B-6052-J110	A20B-0008-0240
	Orientation BS (Position coder type, 2-stage speed change gear spindle)	A06B-6052-J111	A20B-0008-0241
	Orientation CS (Magnetic sensor type, 2-stage speed change gear spindle)	A06B-6052-J120	A20B-0008-0030
	Orientation GS (Magnetic sensor type, 2-stage speed change gear spindle)	A06B-6052-J122	A20B-0008-0031
	Speed gain selection control circuit	A06B-6052-J701	A16B-1700-0020
Orientation A (Position coder type, 2-stage speed change gear spindle)		A06B-6041-J110	A20B-0008-0240
Orientation B (Position coder type, 2-stage speed change gear spindle)		A06B-6041-J111	A20B-0008-0241
Orientation C (Magnetic sencer type, 2-stage speed change gear spindle)		A06B-6041-J120	A20B-0008-0030
Orientation D (Magnetic sencer type, 2-stage speed change gear spindle)		A06B-6041-J121	A20B-0009-0520
Orientation E (Position coder type, 4-stage speed change gear spindle)		A06B-6041-J130	A20B-1000-0460
Orientation F (Position coder type, 4-stage speed change gear spindle)		A06B-6041-J131	A20B-1000-0461
Orientation G (Magnetic sencer type, 2-stage speed change gear spindle)		A06B-6041-J122	A20B-0008-0031
Speed gain selection control circuit		A06B-6044-J701	A16B-1700-0020

2. DAILY MAINTENANCE AND MAINTENANCE TOOLS

Check and clean the following items once every 6 months or so for using the AC spindle motor and AC spindle servo units under a normal condition for a long time.

Take the check frequency into consideration according to the contamination degrees in each item.

2.1 AC Spindle Motor

If the ventilation hole, cooling fan, and fan finger guard (net) of the AC spindle motor become dusty, the radiation efficiency of the motor drops. Clean the AC spindle motor by using the factory air and a vacuum cleaner.

2.2 AC Spindle Servo Unit

Since a cooling fan is mounted at the upper part of the servo unit, its nearby resistor and other parts become dusty after a long-time use. If they are dusty, clean them using the vacuum cleaner or the like.

2.3 Maintenance Tools

2.3.1 Tools used for adjustments

Use tools indicated in Table 2.3.1 (a) for adjustments and tools indicated in Table 2.3.1 (b) for repairing troubles.

Table 2.3.1 (a) Tools used for adjustments

Name	Specification	Use
AC Voltmeter	1 ~ 300 V $\pm 2\%$ or less	AC power voltage measurement
⊕, ⊖ screwdrivers	⊕ large, medium size ⊖ large, medium, small size	

Table 2.3.1 (b) Tools used for repairing troubles

Name	Specification	Use
AC Voltmeter	1 ~ 300 V $\pm 1\%$ or less	AC power voltage measurement
DC voltmeter	1 mV ~ 500 V $\pm 1\%$ or less	DC power voltage measurement and offset voltage check
Circuit tester		Resistance value check
⊕, ⊖ screwdrivers	⊕ large, medium size ⊖ large, medium, small size	

2.4 Major Maintenance Parts

For maintenance parts, see appendix 7 Major maintenance parts.

2.3 Maintenance Tools

2.3.1 Tools used for adjustments
 Use tools indicated in Table 2.3.1 (a) for adjustments and tools indicated in Table 2.3.1 (b) for repairing troubles.

Table 2.3.1 (a) Tools used for adjustments

Name	Specification	Use
AC Voltmeter	1 $\sqrt{300\text{ V} \pm 1\%}$ or less	AC power voltage measurement
⊕, ⊖ screwdrivers	⊕ large, medium size ⊖ large, medium, small size	

Table 2.3.1 (b) Tools used for repairing troubles

Name	Specification	Use
AC Voltmeter	1 $\sqrt{300\text{ V} \pm 1\%}$ or less	AC power voltage measurement
DC voltmeter	1 mV $\sqrt{500\text{ V} \pm 1\%}$ or less	DC power voltage measurement and offset voltage check
Circuit tester		Resistance value check
⊕, ⊖ screwdrivers	⊕ large, medium size ⊖ large, medium, small size	

3. TROUBLESHOOTING

Perform troubleshooting, referring to each item in Table 5 (b) according to trouble conditions if a trouble occurred.

Table 5 Sort of trouble conditions

Item	Trouble conditions	Reference item
1	Power voltage check	3.1
2	Power ON indicator lamp P1L does not light.	3.2
3	Alarm lamp does not light on PCB.	3.3
4	Revolutions are not as specified.	3.4
5	Motor does not rotate.	3.4
6	Vibrations and noises are noticeable during rotation.	3.5
7	An abnormal noise is produced from motor during deceleration.	3.6
8	Motor speed overshoots or hunting occurs.	3.7
9	Cutting power drop	3.8
10	Spindle orientation is not correct.	3.9
11	Acceleration/deceleration time is longer than specified.	3.10

3.1 Power Voltage Check

Check AC power voltage and DC power voltage on PCB check terminals and standard values are as specified in Table 3.1.

Table 3.1 Power voltage check

AC power voltage check	Check at INPUT terminals R,S,T (See 4.2)		
DC power voltage check on PCB	Voltage	Check terminal	Standard value
	+24 V	+24 V - 0 V	About 25 V \pm 10%, ripple about 0.5 V
	+15 V	+15 V - 0 V	+15 V \pm 4% (Not adjustable)
	+5 V	+5 V - 0 V	+5 V \pm 1% (Adjustable by RV15)
	-15 V	-15 V - 0 V	-15 V \pm 4% (Not adjustable)

Check terminal positions

TRUBLESHOOTING

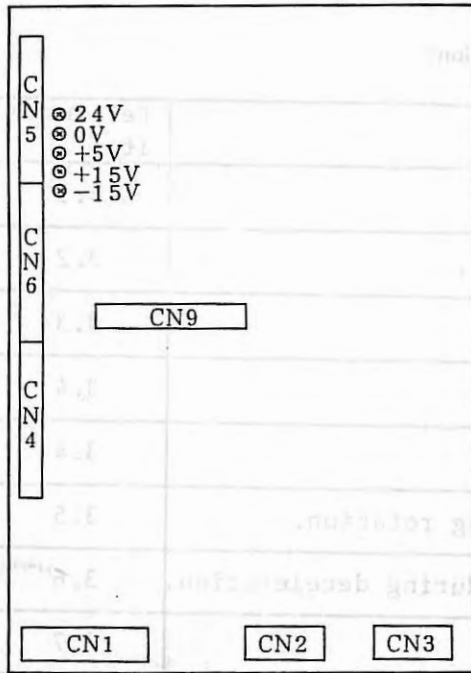

Model 1, 2, small 3

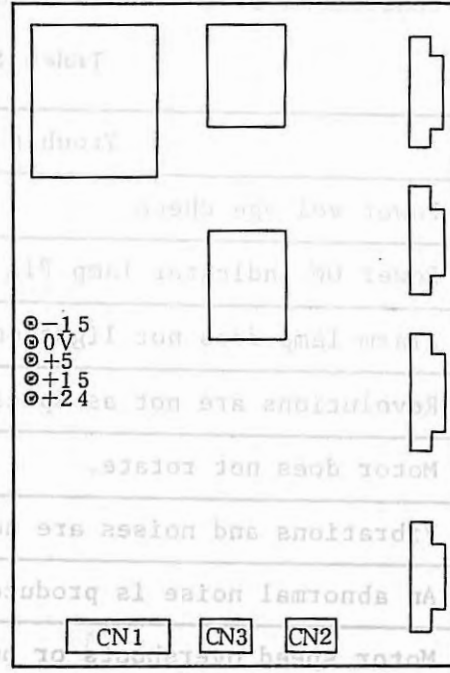

Model 3 ~ 40

11	Acceleration/deceleration time is longer than specified.
10	Spindle orientation is not correct.
9	Cutting power drop
8	Motor does not rotate.
7	Motor does not rotate.
6	At abnormal noise is produced from motor.
5	At abnormal noise and noises are noticeable during rotation.
4	Revolutions are not as listed.
3	Motor does not rotate.
2	Motor does not rotate.
1	Motor does not rotate.

3.1 Power Voltage Check

Check AC power voltage and DC power voltage on PCB check terminals and standard values are as specified in Table 3.1.

Table 3.1 Power voltage check

Check at INPUT terminals R, S, T (See A.2)			AC power voltage check
Standard value	Check terminal	Voltage	DC power voltage check on PCB
About 25 V ±10%, ripple about 0.5 V	+24 V - 0 V	+24 V	
+15 V ±2% (Not adjustable)	+15 V - 0 V	+15 V	
+5 V ±2% (Adjustable by RV12)	+5 V - 0 V	+5 V	
-15 V ±2% (Not adjustable)	-15 V - 0 V	-15 V	

3.2 Power ON Indicator Lamp OIL does not Light

Table 3.2 Check procedure and remedy

Item	Causes	Check procedure	Remedy
1	AC power is not supplied.	Check it at power input terminals R,S,T.	
2	Fuse F4 is blown out.	See appendix 5.	Replace F4 (5A).
3	Fuses AF1, AF2, and AF3 are blown out.	Check if alarm indications of fuses AF1, AF2, AF3 appear. See appendix 5.	Replace fuses AF1, AF2, AF3. Replace PCB, if these fuses are blown out again soon after replacing them.
4	PCB connectors CN6 and CN7 are not plugged correctly.	Check if the connector guide groove appears on the PCB connector surface.	Insert connectors correctly.
5	Neither 19A nor 19B is output because of defective transformer TF.	Check voltage at check terminals 19A-CT and 19B-CT of PCB. Measuring voltage values should be about AC 19 V between these terminals.	Replace transformer TF.
6	PCB power circuit is defective.	Lamp PIL is lit by +5 V and -15 V. Check power voltage according to Table 3.1.	Replace PCB.

Note) Item 2 and 3 differ in AC spindle servo unit model 1/2/small model 3 as follows.

Item	Causes	Check procedure	Remedy
2	Fuse F1 is blown out.	F1 is mounted on the lower PCB. See appendix 6.	Replace F1 (5A).
3	Fuse AF1 or fuse resistors FR1, 2 are blown out.	Check if alarm indication of fuse AF1 appears or not. See appendix 6.	Replace fuse AF1 or fuse resistors FR1, 2. Replace PCB, if these parts are blown out again soon after replacing them.

3.3 Alarm Lamp Lights on PCB

An alarm is displayed by four binary codes using LEDs mounted on PCB as shown in Table 3.3.

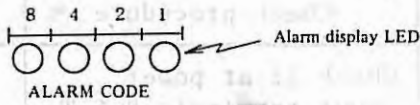

Fig. 3.3 (a)

Table 3.3 (a) Contents of alarms

① Alarm contents in AC spindle servo unit model 1/2/small model 3.

No.	Alarm display (o: Light)				Contents of alarms
	8	4	2	1	
1				o	Motor is overheated (thermostat operates).
2			o		Speed is deviated from the command value due to overload and others.
3			o	o	Regenerative circuit is faulty.
6		o	o		The motor speed exceeds the maximum rated speed (analog system detection).
7		o	o	o	The motor speed exceeds the maximum rated speed (digital system detection).
8	o				Power voltage is higher than specified.
9	o			o	Radiator for power semiconductors is overheated.
10	o		o		+15 V power voltage is abnormally low.
11	o		o	o	DC link voltage is abnormally high.
12	o	o			DC link current is flows excessively.
13	o	o		o	CPU and peripheral parts are defective.
14	o	o	o		ROM is defective.

② Alarm contents in MODEL 3-40.

No.	Alarm display (o: Light)				Contents of alarms
	8	4	2	1	
1				o	Motor is overheated (thermostat operates).
2			o		Speed is deviated from the command value due to overload and others.
3			o	o	Fuse F7 in DC link is blown out.
4		o			Fuses F1, F2, or F3 in AC input circuit are blown out.
5		o		o	Fuse AF2 or AF3 on PCB is blown out.
6		o	o		The motor speed exceeds the maximum rated speed (analog system detection).
7		o	o	o	The motor speed exceeds the maximum rated speed (digital system detection).
8	o				Power voltage (+24 V) is higher than specified.
9	o			o	Radiator for power semiconductors is overheated.
10	o		o		+15 V power voltage is abnormally low.
11	o		o	o	DC link voltage is abnormally high.
12	o	o			DC link current is flows excessively.
13	o	o		o	CPU and peripheral parts are defective.
14	o	o	o		ROM is defective.
15	o	o	o	o	Option circuit is in trouble.

1) Alarm No. [1] Motor is overheated.

Item	Causes	Check procedure	Remedy
1	Built-in fan motor of spindle motor is defective.		Replace fan motor.
2	Overload operation	Check it using a load meter.	Re-examine cutting conditions and tools.
3	Motor cooling system is dirty.		Clean it using compressed air or vacuum cleaner.
4	Disconnection or poor contact of wiring	Check connections between motor and servo unit.	Confirm the connection of connector for signal.

2) Alarm No. [2] Speed is deviated from the command value.

Item	Causes	Check procedure	Remedy
1	Overload	Check it using a load meter.	Re-examine cutting conditions and tools.
2	Transistor module is defective.	Transistor collector-emitter is open.	Replace transistor module.
3	Blow out of fuse in regeneration circuit.	Check fuses F5 and F6 for continuity by using a circuit tester.	Check if the acceleration/deceleration on cycle is too frequent. Replace fuses.
4	Blow out or poor connection of the driver protective fuse on PCB.	Check fuses FA, FB, ... FG for blown out or missing.	Connect fuses securely, and replace blown out fuses, if any.
5	Speed feedback signal is defective.	Check the speed feedback signal level.	Adjust RV18 and RV19. Set duty to about 50%.
6	Wiring failure (disconnection, poor contact, etc.)	Check if connection cables are normally connected.	

Note 1) Speed feedback signal check

Observe the speed feedback signal using an oscilloscope under the rotation command off (motor stop, drive power off) condition after turning on the power supply. Observe it at the following check terminals, while slowly turning the motor by hand.

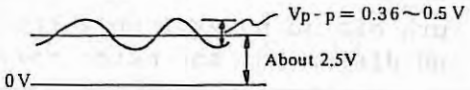
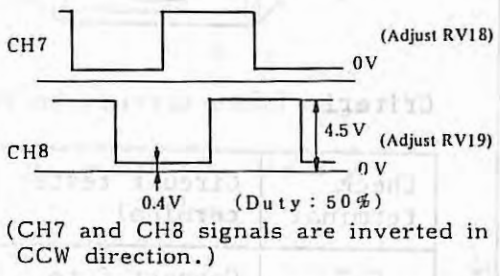
Check terminals	Normal wave forms
CH3-0V (PA)	
CH4-0V (PB)	Same as shown above
CH5-0V (RA)	DC 2.5 V \pm 0.2 V
CH6-0V (RB)	Same as shown above
CH7-0V CH8-0V (In case of CW rotation)	

3) Alarm No. 3

① MODEL 1/2/small MODEL 3 regenerative circuit is faulty.

In MODEL 1/2/small MODEL 3, alarm No. 3 indicates that the regenerative circuit is faulty. A transistor may be defective.

Locate a defective element, and replace it according to the following procedure.

Replace PCB if a transistor is faulty due to a trouble of control PCB. Please contact our service center, if repair is difficult.

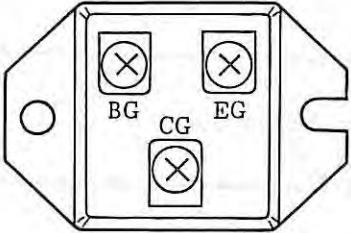
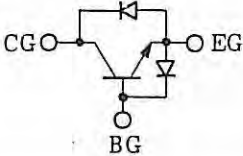
Procedure	Description																									
1	Turn off AC power supply (turn off the magnetics cabinet breaker) and disconnect the motor power cable.																									
2	<p>Remove two screws of the plate which fixes the upper PCB, and check the resistance values of the transistor collector (CG)-emitter (EG), collector (CG)-base (BG), and base (BG)-emitter (EG) of lower PCB, respectively. (See appendix 6 PCB mounting drawing)</p> <div style="display: flex; justify-content: space-around; align-items: center;">   </div> <p>Criteria (when circuit tester is set to $\times 10\Omega$ range)</p> <table border="1" data-bbox="301 953 1321 1632"> <thead> <tr> <th>Check terminal</th> <th>Circuit tester terminal</th> <th>Normal</th> <th>Faulty</th> </tr> </thead> <tbody> <tr> <td rowspan="2">C-E</td> <td>Connect C to + terminal</td> <td>Several 100Ω</td> <td>Short, infinite</td> </tr> <tr> <td>Connect C to - terminal</td> <td>Infinite</td> <td>Short, several 100Ω</td> </tr> <tr> <td rowspan="2">C-B</td> <td>Connect C to + terminal</td> <td>Several 100Ω</td> <td>Short, infinite</td> </tr> <tr> <td>Connect C to - terminal</td> <td>Infinite</td> <td>Short, several 100Ω</td> </tr> <tr> <td rowspan="2">B-E</td> <td>Connect B to + terminal</td> <td>Several 100Ω</td> <td>Short, infinite</td> </tr> <tr> <td>Connect B to - terminal</td> <td>Several 100Ω</td> <td>Short, infinite</td> </tr> </tbody> </table> <p>If a transistor is broken, the collector-emitter and collector-base are shorted, respectively.</p>	Check terminal	Circuit tester terminal	Normal	Faulty	C-E	Connect C to + terminal	Several 100Ω	Short, infinite	Connect C to - terminal	Infinite	Short, several 100Ω	C-B	Connect C to + terminal	Several 100Ω	Short, infinite	Connect C to - terminal	Infinite	Short, several 100Ω	B-E	Connect B to + terminal	Several 100Ω	Short, infinite	Connect B to - terminal	Several 100Ω	Short, infinite
Check terminal	Circuit tester terminal	Normal	Faulty																							
C-E	Connect C to + terminal	Several 100Ω	Short, infinite																							
	Connect C to - terminal	Infinite	Short, several 100Ω																							
C-B	Connect C to + terminal	Several 100Ω	Short, infinite																							
	Connect C to - terminal	Infinite	Short, several 100Ω																							
B-E	Connect B to + terminal	Several 100Ω	Short, infinite																							
	Connect B to - terminal	Several 100Ω	Short, infinite																							
3	Remove the screws of the lower PCB and short bar holder, and replace faulty parts. Apply silicon grease without fail when replacing parts.																									
4	After replacement, reset the lower PCB and short bar holder as before, and check the circuit according to procedure 2.																									

Procedure	Description						
5	<p>Check regenerative transistor driver circuit of lower PCB.</p> <p>① Turn on AC input power supply. Don't apply any rotation commands (SFR,SRV).</p> <p>② Measure the BG-EG voltage by using a circuit tester (2~5 V range). Particularly be careful not to receive any electric shock, since a high voltage (DC 300 V) is applied nearby.</p> <p><u>Criteria</u></p> <div style="border: 1px solid black; padding: 5px; margin: 10px 0;"> <p>A faulty circuit can be checked at glance, since it is different from other normal circuits.</p> </div> <table border="1" style="width: 100%; border-collapse: collapse; margin: 10px 0;"> <thead> <tr> <th style="width: 30%;"></th> <th style="text-align: center;">Base-emitter voltage (based on emitter)</th> </tr> </thead> <tbody> <tr> <td style="text-align: center;">Normal</td> <td style="text-align: center;">About -0.8 V ~ -1.3 V</td> </tr> <tr> <td style="text-align: center;">Faulty</td> <td style="text-align: center;">About 0.0 V ~ -0.8 V</td> </tr> </tbody> </table> <p>If a PCB was confirmed to have been faulty, check if the fuse on driver circuit is blown out or not by using a circuit tester. If the fuse is blown out, replace it and check the circuit again to make sure that the trouble has been recovered.</p>		Base-emitter voltage (based on emitter)	Normal	About -0.8 V ~ -1.3 V	Faulty	About 0.0 V ~ -0.8 V
	Base-emitter voltage (based on emitter)						
Normal	About -0.8 V ~ -1.3 V						
Faulty	About 0.0 V ~ -0.8 V						
6	Fix two screws of the plate which fixes the upper PCB.						
7	Connect the motor power cable and start operation again.						

- ② MODEL 3 ~ 40 DC link fuse (F7) is blown out.
 In MODEL 3 ~ 40, alarm No. 3 indicates that the DC link fuse (F7) is blown out.
 In this case, a transistor module may be defective.
 Locate and replace the defective element according to the following procedure.
 Replace PCB if the transistor module may be faulty due to a trouble of the control PCB.
 Please contact FANUC service center, if repair is difficult.
 (The fuse name is F4 in MODEL 30 and 40)

Procedure	Description
1	Turn off AC power supply (turn off the magnetics cabinet breaker) and disconnect the motor power cable.

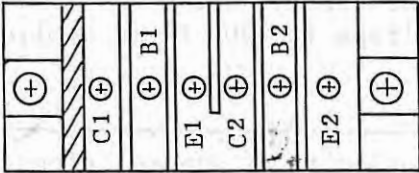
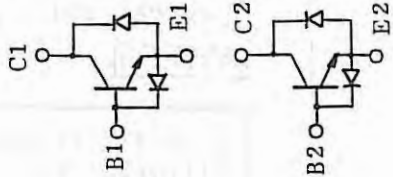
Procedure	Description																									
2	<p>Remove PCB and check the resistance values of the transistor module collector (C1,C2)-emitter (E1,E2), connector (C1,C2)-base (B1,B2) and base (B1,B2)-emitter (E1,E2), respectively.</p> <div style="display: flex; justify-content: space-around; align-items: flex-start;">   </div> <p>Criteria (circuit tester range x10Ω)</p> <table border="1" data-bbox="292 800 1316 1470"> <thead> <tr> <th>Terminal to be observed</th> <th>Circuit tester terminal</th> <th>Normal</th> <th>Faulty</th> </tr> </thead> <tbody> <tr> <td rowspan="2">C-E</td> <td>Connect C to + terminal</td> <td>Several 100Ω</td> <td>Short, infinite</td> </tr> <tr> <td>Connect C to - terminal</td> <td>Infinite</td> <td>Short, several 100Ω</td> </tr> <tr> <td rowspan="2">C-B</td> <td>Connect C to + terminal</td> <td>Several 100Ω</td> <td>Short, infinite</td> </tr> <tr> <td>Connect C to - terminal</td> <td>Infinite</td> <td>Short, several 100Ω</td> </tr> <tr> <td rowspan="2">B-E</td> <td>Connect B to + terminal</td> <td>Several 100Ω</td> <td>Short, infinite</td> </tr> <tr> <td>Connect B to - terminal</td> <td>Several 100Ω</td> <td>Short, infinite</td> </tr> </tbody> </table> <p>If a transistor is broken, the collector-emitter and collector-base are shorted, respectively.</p>	Terminal to be observed	Circuit tester terminal	Normal	Faulty	C-E	Connect C to + terminal	Several 100Ω	Short, infinite	Connect C to - terminal	Infinite	Short, several 100Ω	C-B	Connect C to + terminal	Several 100Ω	Short, infinite	Connect C to - terminal	Infinite	Short, several 100Ω	B-E	Connect B to + terminal	Several 100Ω	Short, infinite	Connect B to - terminal	Several 100Ω	Short, infinite
Terminal to be observed	Circuit tester terminal	Normal	Faulty																							
C-E	Connect C to + terminal	Several 100Ω	Short, infinite																							
	Connect C to - terminal	Infinite	Short, several 100Ω																							
C-B	Connect C to + terminal	Several 100Ω	Short, infinite																							
	Connect C to - terminal	Infinite	Short, several 100Ω																							
B-E	Connect B to + terminal	Several 100Ω	Short, infinite																							
	Connect B to - terminal	Several 100Ω	Short, infinite																							
3	Replace faulty parts. Apply a coat of silicon grease without fail when replacing them.																									
4	After replacement, recheck the circuit according to procedure 2.																									

Procedure	Description																																																																		
5	<p>Check the transistor drive circuit on PCB.</p> <p>① Remove DC link fuse F7 and turn on AC input power supply. Don't apply any rotation commands (SFR,SRV).</p> <p>② Measure the base-emitter voltage of eight transistors (U,V,W regenerative control circuits)(at connectors CN6,7) by using a circuit tester (2 ~ 5 V range). Particularly be careful since a high voltage (DC 300 V) is applied to CN6 and CN7. Be careful not to damage any connector when checking the connector using the probe.</p> <p>Criteria</p> <p>A faulty circuit can be checked at glance, since it is different from other normal circuits.</p> <table border="1" data-bbox="417 776 1433 968"> <thead> <tr> <th></th> <th>Base-emitter voltage (based on emitter)</th> </tr> </thead> <tbody> <tr> <td>Normal</td> <td>About -0.8 V ~ -1.3 V</td> </tr> <tr> <td>Faulty</td> <td>About 0.0 V ~ -0.8 V</td> </tr> </tbody> </table> <p>Connector CN6 terminal</p> <table border="1" data-bbox="417 1063 1387 1130"> <tr> <td>1</td><td>2</td><td>3</td><td>4</td><td>5</td><td>6</td><td>7</td><td>8</td><td>9</td><td>10</td><td>11</td><td>12</td><td>13</td><td>14</td><td>15</td> </tr> <tr> <td></td><td>5C</td><td>5B</td><td>5E</td><td>6C</td><td>6B</td><td>6E</td><td>7C</td><td>7B</td><td>7E</td><td>8C</td><td>8B</td><td>8E</td><td></td><td></td> </tr> </table> <p>Connector CN7 terminals</p> <table border="1" data-bbox="417 1225 1387 1291"> <tr> <td>1</td><td>2</td><td>3</td><td>4</td><td>5</td><td>6</td><td>7</td><td>8</td><td>9</td><td>10</td><td>11</td><td>12</td><td>13</td><td>14</td><td>15</td> </tr> <tr> <td>1C</td><td>1B</td><td>1E</td><td>2C</td><td>2B</td><td>2E</td><td>3C</td><td>3B</td><td>3E</td><td>4C</td><td>4B</td><td>4E</td><td></td><td></td><td></td> </tr> </table> <p>(References)</p> <p>The following figure indicates waveforms under normal and abnormal conditions. Refer to these waveforms, when it is difficult to check a trouble by using a circuit tester.</p> <div data-bbox="417 1462 1433 1561" style="border: 1px solid black; padding: 5px;"> <p>Be careful since a high voltage (about DC 300 V) is applied to CN6 and CN7.</p> </div> <p>Apply normal rotation and reverse rotation commands. (The velocity command is 0rpm)</p> <p>Observe the base-emitter waveform of each transistor (U,V,W regenerative circuits) at CN6 and CN7 connectors by using an insulated oscilloscope.</p> <p>When F7 is removed, alarm No. 3 occurs.</p> <p>Short check terminals "ARS" and 0V using a clip or the like.</p> <p>After observation, detach the clip without fail.</p>		Base-emitter voltage (based on emitter)	Normal	About -0.8 V ~ -1.3 V	Faulty	About 0.0 V ~ -0.8 V	1	2	3	4	5	6	7	8	9	10	11	12	13	14	15		5C	5B	5E	6C	6B	6E	7C	7B	7E	8C	8B	8E			1	2	3	4	5	6	7	8	9	10	11	12	13	14	15	1C	1B	1E	2C	2B	2E	3C	3B	3E	4C	4B	4E			
	Base-emitter voltage (based on emitter)																																																																		
Normal	About -0.8 V ~ -1.3 V																																																																		
Faulty	About 0.0 V ~ -0.8 V																																																																		
1	2	3	4	5	6	7	8	9	10	11	12	13	14	15																																																					
	5C	5B	5E	6C	6B	6E	7C	7B	7E	8C	8B	8E																																																							
1	2	3	4	5	6	7	8	9	10	11	12	13	14	15																																																					
1C	1B	1E	2C	2B	2E	3C	3B	3E	4C	4B	4E																																																								

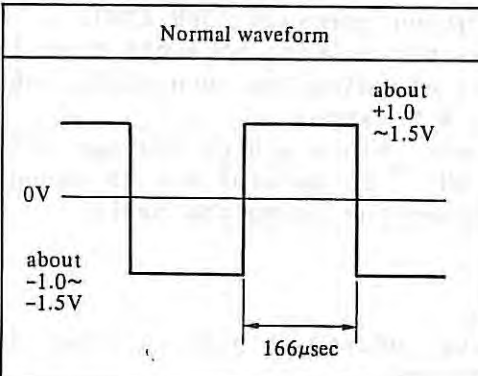
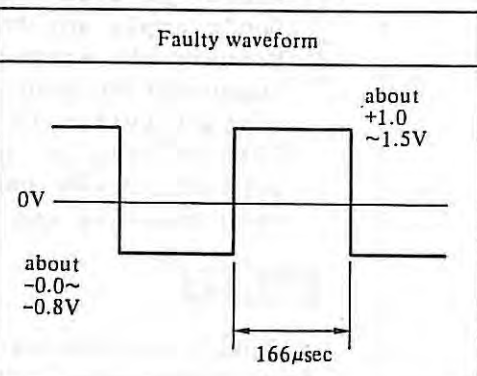
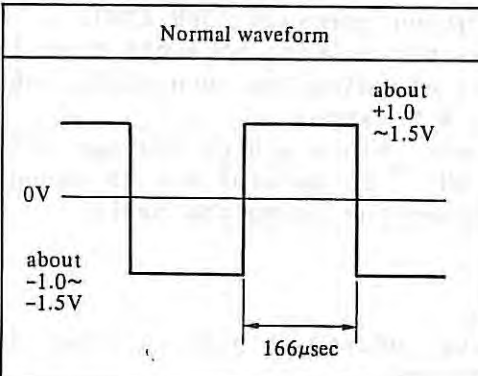
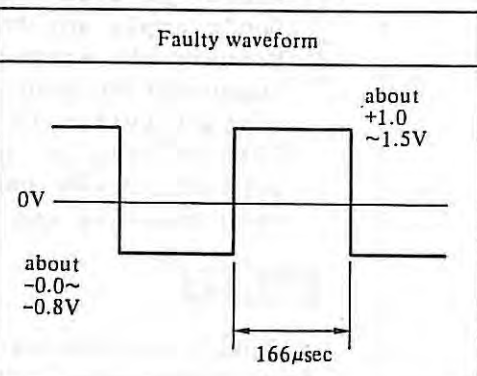
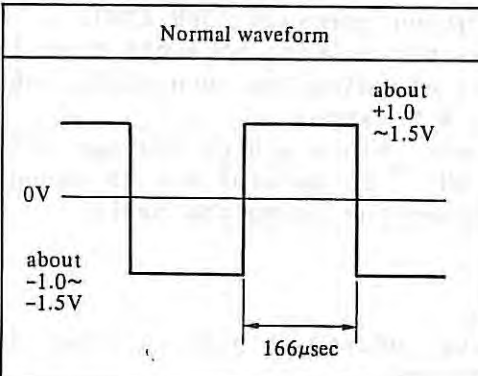
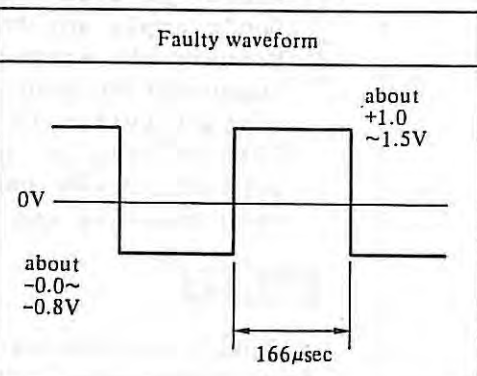
Procedure	Description				
5	<div style="text-align: center;"> <table border="1" style="width: 100%; border-collapse: collapse;"> <thead> <tr> <th style="width: 50%;">Normal waveform</th> <th style="width: 50%;">Faulty waveform</th> </tr> </thead> <tbody> <tr> <td style="text-align: center;">  </td> <td style="text-align: center;">  </td> </tr> </tbody> </table> </div> <p>Perform the following repair, if a PCB was found to have been faulty.</p> <p>(1) Fuses FA, FB...FG of the driver circuit are mounted in and after PCB version No. 17H. Check if these fuses are normal by using a circuit tester. If a fuse is blown out, replace it, and check steps (1),(2) again to make sure that the trouble has been recovered.</p> <p>(2) Replace PCB if a PCB does not correspond to (1) or no fuse is blown out in (1).</p>	Normal waveform	Faulty waveform		
Normal waveform	Faulty waveform				
					
6	Connect the motor power cable, replace fuse F7, and restart the operation.				

4) Alarm No. 4 AC input fuses (F1, F2, F3) are blown out.

Item	Causes	Check procedure	Remedy
1	High impedance on AC power supply side. (Note 1) (Example) Two transformers are connected in series or when a variable auto-transformer is connected.	<ul style="list-style-type: none"> ◦ Alarm No. 4 lights only when the motor speed is reduced from high speed. ◦ Alarm No. 4 may also light, irrespective of normal condition of F1∧F3. 	<ul style="list-style-type: none"> ◦ Replace the power supply having low power impedance. ◦ Looseness of input cable connector. Example: Open phase due to loosened screws.
2	Transistor module is defective.	See alarm No. 3.	See alarm No. 3. Replace transistor module and fuse.

Item	Causes	Check procedure	Remedy
3	Diode module or thyristor module is defective.	After disconnecting cables of diode modules DM1v3 and thyristor modules SM1v3, check A-K by using a circuit tester. (Defective parts are generally shorted.)	Replace defective parts and fuses.
4	Surge absorbers or capacitors are defective.	Check surge absorbers Z1v3 and capacitors C4v6.	Replace defective parts and fuses.
5	Input fuses not blown out.	Check if it is not applicable to item 1.	Replace the PCB if not applicable to item 1.

Note) Power impedance checking method.

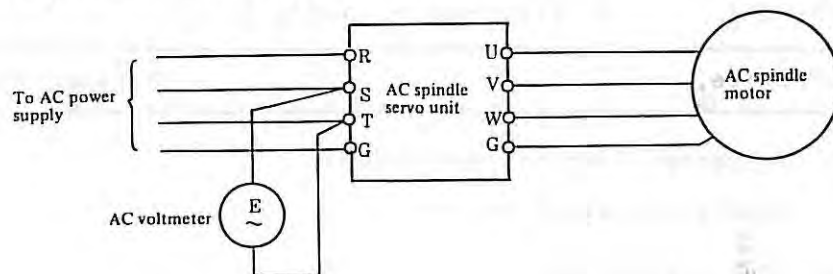

1 Calculation formula

$$\frac{E_0 - E_1}{E_0} \times 100 (\%) < 7 (\%)$$

where E_0 : Voltage when the motor stops operating.

E_1 : Voltage during acceleration of motor or voltage just before the motor speed begins lowering with a load applied.

2 Input power specifications

Name	Specifications
Nominal rated voltage	AC200/230V
Allowable voltage fluctuation width	-15% ~ +10%
Power frequency	50/60Hz
Power impedance	Voltage fluctuation due to load (120% load at 30 minute rating): Less than 7%

5) Alarm No. [5] Fuses AF2 or AF3 on PCB are blown out.

Item	Causes	Check procedure	Remedy
1	PCB is defective	Check AC input voltage. See 5 in para 3.2.	Replace PCB.
2	Power voltage is abnormal.		

Note) This alarm does not occur in MODEL 1/2/small MODEL 3.

6) Alarm No. [6] Overspeed (analog detection)

Item	Causes	Check procedure	Remedy
1	PCB setting failure or adjusting failure	Check PCB for normal setting and adjustment (S2, S3, S5).	Change S5 setting.
2	Wrong specification of ROM (memory IC)	Check specification referring to Table 1.1.	Replace ROM.
3	PCB is defective.		Replace PCB.

7) Alarm No. [7] Overspeed (digital detection)

Same as in alarm No. 6

8) Alarm No. [8] +24V overvoltage

Item	Causes	Check procedure	Remedy
1	AC power voltage exceeds +10% of the rated value.	Check power voltage.	
2	Setting failure of voltage selection toggle switch.	Check power voltage.	Setting from 200V to 230V.

9) Alarm No. [9] Radiator is overheated.

Item	Causes	Check procedure	Remedy
1	Cooling fan is defective.	Check if fan is stopping.	Replace fan.
2	Overload operation.	Check load by using a load meter.	Re-examine the cutting condition.
3	Dusty and dirty.		Clean using compressed air or vacuum cleaner.

10) Alarm No. [10] +15V voltage drop.

This alarm indicates abnormally low AC power voltage (-15% or less).

- 11) Alarm No. 11 Overvoltage of DC link circuit.
(Regenerative circuit is faulty ... Regeneration failure)

Item	Causes	Check procedure	Remedy
1	Fuses F5 and F6 are blown out.	Check fuses F5, F6 by using a circuit tester. If these fuses are blown out, check transistor module by the same procedure as in alarm No. 3.	Replace fuses.
2	High power impedance.		Examine AC power specification.
3	PCB is defective.		Replace PCB.

Note) Item 1 does not apply to MODEL 1/2/small MODEL 3.

- 12) Alarm No. 12 Overcurrent flows to DC link circuit.

Item	Causes	Check procedure	Remedy
1	Output terminals or internal circuit of motor is shorted.	Check connections.	
2	Transistor module is defective.	Check it by the same procedure as in alarm No. 3.	Replace defective parts.
3	PCB is defective.		Replace PCB.

Note) Method of replacing transistor modules in MODEL 1/2/small MODEL 3.

Procedure	Description
1	Turn off AC power supply (turn off the magnetics cabinet breaker) and disconnect the motor power cable.
2	Disconnect the cables (including flat cables) which connect the upper and lower PCB.
3	Remove one upper screw and one lower screw, and open the cabinet to the front left together with the mounting plate without detaching the upper PCB.

Procedure	Description
-----------	-------------

4

Check resistance values of the following terminals of transistor modules on the lower PCB by using a circuit tester.

- (1) P (collector) - U₀,V₀,W₀ (emitter)
- (2) U₀,V₀,W₀ (collector) - N (emitter)
- (3) P (collector) - B1,B2,B3 (base)
- (4) U₀,V₀,W₀ (collector) - B2,B4,B6 (base)
- (5) B1,B3,B5 (base) - U₀,V₀,W₀ (emitter)
- (6) B2,B4,B6 (base) - N (emitter)

(See appendix 6 PCB installation drawing.)

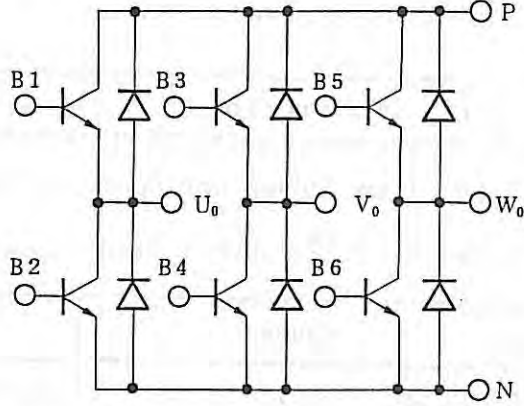
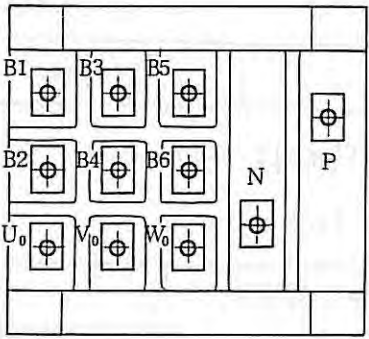

Criteria (circuit tester range x 10Ω)

Terminal to be observed	Circuit tester terminal	Normal	Faulty
C-E	Connect C to + terminal	Several 100Ω	Short, infinite
	Connect C to - terminal	Infinite	Short, several 100Ω
C-B	Connect C to + terminal	Several 100Ω	Short, infinite
	Connect C to - terminal	Infinite	Short, several 100Ω
B-E	Connect B to + terminal	Several 100Ω	Short, infinite
	Connect B to - terminal	Several 100Ω	Short, several 100Ω

If a transistor is broken, the collector-emitter and collector-base are usually shorted, respectively.

Procedure	Description						
3	Replace faulty parts. Remove the lower PCB first (See Table 6.2 (a)-(1)). Divide the connection part of the short bar holder into 2 parts by using cutting pliers or the like, remove the right side part, and replace the transistor module. Apply a coat of silicon grease without fail when replacing these parts.						
4	After replacement, mount the short bar holder and mount the lower PCB onto the short bar holder (See Table 6.2 (b)-(1)). Recheck the circuit according to procedure 2.						
5	<p>Check the PCB transistor driver circuit.</p> <p>(1) Turn on the AC input power supply. Don't apply any rotation commands (SFR,SRV).</p> <p>(2) Measure the base-emitter voltage of six transistors (U,V,W phases) by using a circuit tester. Particularly be careful since a high voltage is applied to the vicinity of the driver circuit so as not to receive any electric shock.</p> <p>Criteria</p> <div style="border: 1px solid black; padding: 5px; margin: 10px 0;"> <p>A faulty circuit can be checked at glance, since it is different from other normal circuit.</p> </div> <table border="1" style="width: 100%; border-collapse: collapse; margin: 10px 0;"> <thead> <tr> <th style="width: 30%;"></th> <th style="text-align: center;">Base-emitter voltage (based on emitter)</th> </tr> </thead> <tbody> <tr> <td style="text-align: center;">Normal</td> <td style="text-align: center;">About -0.8 V ~ -1.3 V</td> </tr> <tr> <td style="text-align: center;">Faulty</td> <td style="text-align: center;">About 0.0 V ~ -0.8 V</td> </tr> </tbody> </table> <p>(Reference) The following figure shows normal and abnormal waveforms as a reference when they cannot be checked easily by using a circuit tester.</p> <div style="border: 1px solid black; padding: 5px; margin: 10px 0;"> <p>Particularly be careful since a high voltage (about 300V) is applied to the vicinity of the driver circuit.</p> </div> <p>Apply normal rotation or reverse rotation command. (The velocity command specifies 0 rpm). Observe the base-emitter waveform of each transistor (U,V,W phases) at each terminal of the lower PCB by using an insulated oscilloscope. Short the check terminal ARS to 0 V by using a clip or the like. Disconnect the clip without fail after observation.</p>		Base-emitter voltage (based on emitter)	Normal	About -0.8 V ~ -1.3 V	Faulty	About 0.0 V ~ -0.8 V
	Base-emitter voltage (based on emitter)						
Normal	About -0.8 V ~ -1.3 V						
Faulty	About 0.0 V ~ -0.8 V						

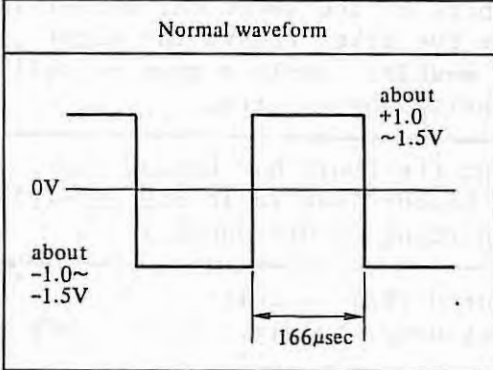
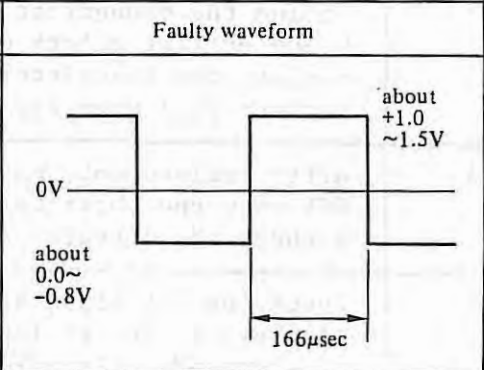
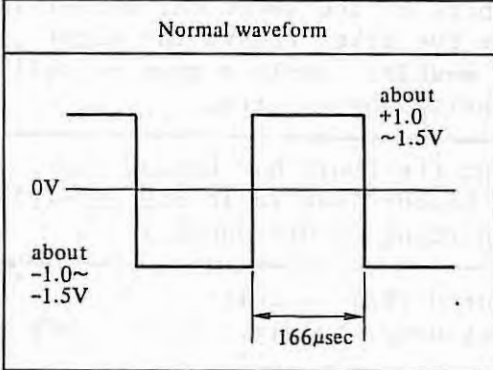
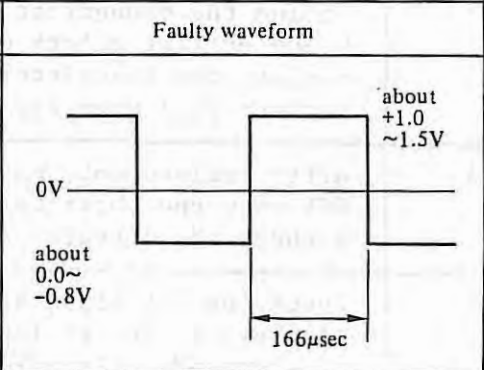
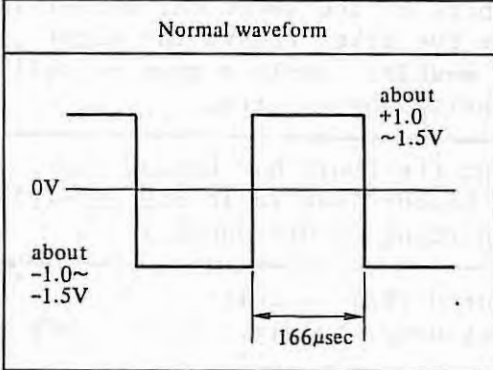
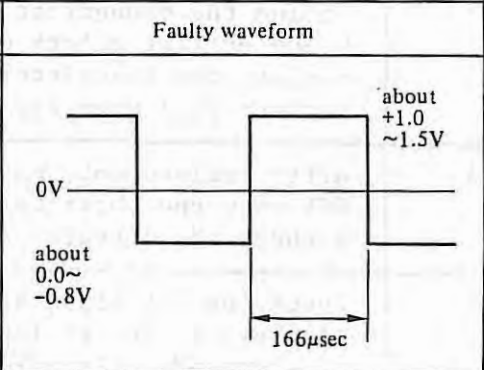
Procedure	Description				
	<div style="text-align: center;"> <table border="1" style="width: 100%;"> <thead> <tr> <th style="width: 50%;">Normal waveform</th> <th style="width: 50%;">Faulty waveform</th> </tr> </thead> <tbody> <tr> <td style="text-align: center;">  </td> <td style="text-align: center;">  </td> </tr> </tbody> </table> </div> <p>Repair the circuit if the PCB was confirmed to be faulty. Fuses FA, FB...FG of the driver circuit are mounted on PCB. Check these fuses for normal condition by using a circuit tester. Replace faulty fuses, if any, and check (1),(2) again to make sure that the trouble has been recovered.</p>	Normal waveform	Faulty waveform		
Normal waveform	Faulty waveform				
					
6	Connect the motor power cable and restart the operation.				

13) Alarm No. 13 CPU alarm.
Replace PCB.

14) Alarm No. 14 ROM is defective.

Item	Causes	Check procedure	Remedy
1	ROM is not mounted at all or not properly mounted.	Check if ROM is unplugged from the socket or if its leads are broken.	Mount ROM properly.
2	ROM is defective.		Replace ROM having correct specification. (see Table 1.1)

15) Alarm No. 15 Option alarm.

Item	Causes	Check procedure	Remedy
1	Spindle selector circuit or other option PCB are faulty.		Replace PCB.
2	Option PCB connection is in error.		Check and correct the connection.

3.4 Motor does not Rotate, or Motor does not Rotate at the Specified Revolutions

Item	Causes	Check procedure	Remedy
1	Fault analysis	Alarm lamp lights on spindle servo unit when rotation command is given.	Proceed to 3.3.
		Alarm lamp does not light.	Proceed to item 2 or 3.
2	Command signal connection failure	Check signal cable Connection.	
3	PCB is defective.		Replace PCB.

3.5 Vibrations or Noises are Noticeable during Rotation

Item	Causes	Check procedure	Remedy
1	Motor is defective.		Replace motor.
2	PCB is defective.	Run the motor idly. When the connector CN2 from AC spindle servo unit while rotating the motor, overheat alarm occurs, and the motor runs idly. If vibrations and noises are reduced during idle run as compared with normal rotation time, the control circuit is defective.	Replace PCB.

3.6 Abnormal Noise is Produced from Motor during Deceleration

During deceleration of the motor, energy is regenerated to the power supply through the regenerative control circuit (this energy is consumed by resistors in MODEL 1/2/small MODEL 3)

If the regenerative energy is excessive, the regeneration limiter circuit operates to change the motor current waveform, causing an abnormal noise to be produced from the motor.

If such a case, turn RV6 (this is normally set to division 3) counterclockwise until no abnormal noise is produced. When RV6 is turned counterclockwise, the deceleration time increases.

3.7 Speed Overshooting or Hunting Occurs

Item	Causes	Check procedure	Remedy
1	PCB setting or adjustment failure.	Increase gain by turning RV12 (standard division 5) clockwise.	Readjust RV12.
2	Spindle hunting occurs.	Decrease gain by turning RV12 counterclockwise.	Readjust RV12.

3.8 Cutting Power is Low

Item	Causes	Check procedure	Remedy
1	ROM specification is wrong.	Check it referring to Table 1.1.	Replace ROM.
2	Torque limitation command is applied.	Check signal.	
3	Loosened belt.	Check belt for proper tension.	

3.9 Orientation is not Correct

Item	Causes	Check procedure	Remedy
1	Setting or adjusting failure of orientation control circuit.	Check if circuit is set and adjusted as specified in data sheet.	Refer to setting and adjustment of spindle orientation control circuit in chapter 7.
2	Orientation control circuit PCB is defective.		Replace PCB.
3	Spindle control PCB is maladjusted.		Adjust PCB.
4	Position detection (position coder or magnetic sensor) is defective.	Check the output signal waveform of the position detector. (For the magnetic sensor, refer to appendix 10.)	Replace the position coder or magnetic sensor.

3.10 Acceleration/Deceleration Time is Long

Item	Causes	Check procedure	Remedy
1	Torque limitation command is applied.	Check signal.	
2	ROM specification is wrong.		Replace ROM.
3	Defection of the regenerative circuit.	See alarm No. 2 item 3, 4.	
4	PCB is maladjusted.	If RV6 is set lower than necessary, the deceleration time increases (see para. 3.6).	Readjust RV6.

4. INSTALLATION

4.1 Installation Procedure

Observe the checking procedure shown in the following table at the installation time.

Item	Description	Remarks
1	Check if specification of motor, servo unit, options, etc. are correct.	Check if motor corresponds to units, PCB, and ROM correctly according to table 1.1.
2	Check appearance for damage	Check resistors, and PCB parts mounted on the upper part for damage.
3	Check the working AC power supply for voltage, voltage fluctuation, power capacity (KVA) and frequency.	See table 4.2.1.
4	Connect the earth wire, power cable, drive power cable, and signal cable (See note 1).	See 4.2, 4.3, 4.4 and appendix 1.
5	Check setting and adjustment results.	See 5.1.
6	Turn on AC power supply, and make sure that green lamp PIL light on PCB.	
7	Give rotation command to check the normal rotation and reverse rotation movement.	
8	Check the operation over the entire velocity range.	
9	Adjust spindle orientation circuit.	See section 7.

Note) Check the connection with discharge resistor for MODEL 1/2/small MODEL 3.

4.2 Power Connection

4.2.1 Power voltage and capacity check

Measure the AC power voltage before connecting the power supply, and take the following measure according to power voltage.

Table 4.2.1 (a) Measure to AC power voltage

AC power voltage	Nominal voltage	Measures
170 V ~ 220 V	200 V	Set toggle switch SW to 200 V
210 V ~ 253 V	230 V	Set toggle switch SW to 230 V
Higher than 254 V	380 V 550 V	Set input voltage to 230 V by using insulation transformer

The input power specification of the AC spindle servo unit is as specified in Table 4.2.1 (a).

Use a power source having the power capacity having a sufficient allowance so that no trouble due to voltage drop occurs with the maximum load.

Table 4.2.1 (b) Input power specifications of AC spindle servo unit

Nominal rated voltage		AC 200 V/230 V (SW selection), 3 phases											
Allowable voltage fluctuation		-15% ~ +10%											
Frequency		50 Hz/60Hz <u>+1</u> Hz (Note 1)											
Power capacity	Motor model	1	2	3	6	8	12	15	18	22	30	40	
	Capacity (KVA) with 30-minute rating	4	7	9	12	17	22	26	32	37	54	63	

Note 1) Model 40 (A06B-6052-H140) requires the 50/60 Hz selection. However, this selection is not required for other models.

4.2.2 Protective earth connection

Connect the protective earth to connection terminal G before connecting the power supply.

Use the protective earth having sufficient capacity as compared with the feeder circuit breaker capacity.

4.2.3 Power connection

Connect the power cable after protective earth connection.

The power phase rotation is not specified for AC spindle servo unit.

4.3 AC Spindle Motor Connection

Connect the AC spindle motor according to the connection diagram in appendix 1. If the drive power cable connection sequence is in error, vibrations are produced or alarm No. 2 occurs to stop the motor. Connect protective earth "G" without fail.

4.4 Single Cable Connection

Connect the signal cable according to the connection diagram in appendix 1.

5. SETTING AND ADJUSTMENTS









5.1 Setting of Unit and PCB

For the parts on the unit and PCBs, refer to mounting layout of parts (APPENDIX 5 and 6). Confirm the following setting before turning on the power switch.



Table 5.1 (a) Setting to be confirmed before turning on the power switch

No.	Check items	Remarks
1	Setting of voltage selection	See para. 4.2
2	Setting (short bars) check	See table 5.1 (b)

Table 5.1 (b) Setting

Setting terminal number	Contents		Setting	Setting at shipment from FANUC
S1	Machine ready signal (MRDY)	Used	OFF  ON	OFF
		Not used	ON  ON	
S2	Analog override	Used	OFF  ON	OFF
		Not used	ON  ON	
S3	Same as the above	Used	ON  ON	ON
		Not used	OFF  ON	
S4	Velocity command signal	Use of external analog voltage command	OFF  ON	OFF
		Use of R01 ~ R12 commands	ON  ON	

Setting terminal number		Contents	Setting		Setting at shipment from FANUC																																
S5	MODEL 1	Setting of velocity feedback amount to rated command	4000, 4500, 8000 rpm	A,B: OFF	<input type="radio"/> A <input type="radio"/> B	Set to the rating of the motor employed																															
	2		6000 rpm	B: ON	<input type="radio"/> A <input checked="" type="radio"/> B																																
	Small MODEL 3		20000 rpm	A: ON	<input checked="" type="radio"/> A <input type="radio"/> B																																
	MODEL 3 } 40		4500 rpm	B: Shorted	<input checked="" type="radio"/> B <input type="radio"/> A																																
			6000 rpm	A: Shorted	<input type="radio"/> B <input checked="" type="radio"/> A																																
			8000 rpm	A and B: Opened	<input type="radio"/> B <input type="radio"/> A																																
S6	Velocity control phase compensation	S6	Depends on motor and PPW version numbers. See table 5.1 (c)																																		
S7		S7			S8	Delay time required until motor is de-energized	0 sec/option	OFF	<input type="radio"/> ON	ON (Note 2)	0.2 sec/standard	ON	<input checked="" type="radio"/> ON	S9	Machine ready signal function	MCC is turned off	OFF	<input type="radio"/> ON	OFF	MCC is not turned off	ON	<input checked="" type="radio"/> ON	S10	Overcurrent detection level	Labeled	OFF	<input type="radio"/> ON	Determined as specified on the unit label (Note 3)	Not labeled	ON	<input checked="" type="radio"/> ON	S11	Soft start/stop time constant switching (Adjust by RV20)	0.6 8 sec	A	<input type="radio"/> B <input checked="" type="radio"/> A	A
S8	Delay time required until motor is de-energized	0 sec/option	OFF	<input type="radio"/> ON			ON (Note 2)																														
		0.2 sec/standard	ON	<input checked="" type="radio"/> ON																																	
S9	Machine ready signal function	MCC is turned off	OFF	<input type="radio"/> ON	OFF																																
		MCC is not turned off	ON	<input checked="" type="radio"/> ON																																	
S10	Overcurrent detection level	Labeled	OFF	<input type="radio"/> ON	Determined as specified on the unit label (Note 3)																																
		Not labeled	ON	<input checked="" type="radio"/> ON																																	
S11	Soft start/stop time constant switching (Adjust by RV20)	0.6 8 sec	A	<input type="radio"/> B <input checked="" type="radio"/> A	A																																
		3.5 40 sec	B	<input type="radio"/> B <input type="radio"/> A																																	

Setting terminal number	Contents		Setting	Setting at shipment from FANUC
S15	Speed-zero detecting	Maximum revolution 10000 ~ 20000 rpm	ON  ON	Set to the rating of the motor employed. (Note 4)
		Maximum revolution lower than 10000 rpm	OFF  OFF	

Note 1) Be careful since S5 setting differs between MODEL 1, 2, small MODEL 3 and MODEL 3 - 40.

Note 2) Insert a short bar without fail even when setting is turned off.

Note 3) Turn on S10 only when the label at the upper part of the PCB mounting plate represents that S10 is turned on.

Note 4) S15 is used for AC spindle servo unit MODEL 1/2/small MODEL 3 only.

Note 5) Presence or absence of setting terminal S8 to S15.

	a	b	c
S8	Presence	Presence	Absence
S9	Presence	Presence	Absence
S10	Absence	Presence*	Presence
S11	Absence	Absence	Presence
S15	Presence	Absence	Absence

a: MODEL 1, 2, small 3S

b: MODEL 3 to 22

c: MODEL 30, 40

* S10 was added after PCB edition 17H.

Variable resistors RV1 - RV19 of the spindle control circuit PCB have been adjusted at factory before shipment, and their adjustments are no longer necessary, in principle. However, the set values of variable resistors shown in Table 5.1 (d) are changeable as required. Readjust variable resistors shown in Table 5.1 (e) after turning on the power supply, if fine adjustment is required for offset, rotating speed, etc.

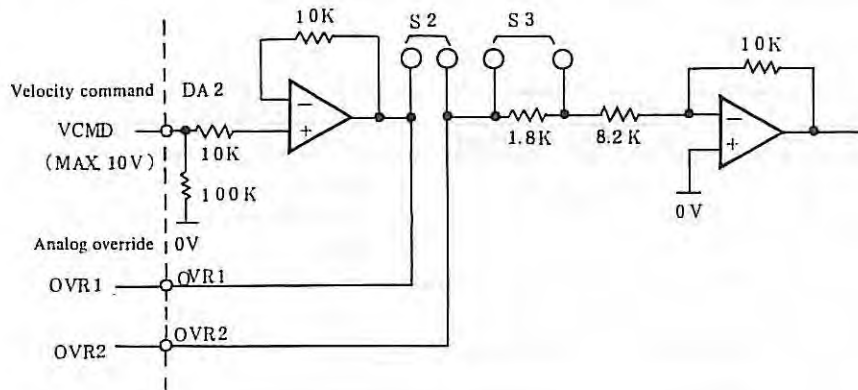

Setting	Use of override		Unuse of override
	Override range Max 120%	Override range Max 100%	
S2	OFF	OFF	ON
S3	ON	OFF	OFF

Fig. 5.1 (a) Analog override circuit

Table 5.1 (c) Setting of S6 and S7

i) PCB A20B-0009-0534 - 539

Applicable motor	ROM		Overall version number of PCB	Setting	
	Type	Version number		OFF	ON
MODEL 15	J04	After 001F	After 14F	OFF	ON
MODEL 18	J05	After 001C	After 14F	OFF	ON
MODEL 22	J06	After 001A	After 14F	OFF	ON

ii) PCB A20B-1000-0690 - 0693

Applicable motor	ROM		Setting	
	Type	Version number	S6	S7
MODEL 3	J10	After 001E	OFF	ON
MODEL 6	J11	After 001E	OFF	ON
MODEL 8	J02	After 001G	OFF	ON
MODEL 12	J03	After 001G	OFF	ON

iii) PCB A20B-1000-0700 - 0701

Applicable motor	ROM		Setting	
	Type	Version number	S6	S7
MODEL 30	J06	After 001A	OFF	ON
MODEL 40	J07	After 001A	OFF	ON

iv) PCB A16B-1100 - 0080

Applicable motor	ROM		Setting	
	Type	Version number	S6	S7
MODEL 1	J21	After 001A	OFF	ON
MODEL 2	J22	After 001A	OFF	ON
MODEL 3	J23	After 001A	OFF	ON

1) Variable resistors whose set values are changeable.

Table 5.1 (d)

Variable resistor number	Use	Standard adjustment at shipment from FANUC	Setting change method
RV3	Set speed arrival level	Sends speed arrival signal when the motor speed reaches 85 - 115% of the command speed.	See appendix 8.
RV4	Speed detection level	3% of the maximum speed is detected.	See appendix 8.
RV5	Torque limit value		See appendix 8.
RV20	Soft start/stop time constant adjust		See appendix 8. (Note 1)

2) Variable resistors for fine adjustment of offset and rated speed.

Table 5.1 (e)

Variable resistor number	Use	Adjusting method
RV1	Adjusts the velocity command voltage level.	See appendix 8.
RV2	Adjusts the velocity command voltage offset.	See appendix 8.
RV9	Finely adjusts the rated speed in normal rotation (SFR).	See appendix 8. (Note 2)
R11	Finely adjusts the rated speed in reverse rotation (SRV).	See appendix 8. (Note 2)
R13	Adjusts the offset when zero speed is commanded.	See appendix 8.

Note 1) Soft start/stop function is employed only for MODEL 30 and 40. RV20 is not provided to other models.

Note 2) RV9A, B/RV11A, B are provided for AC spindle servo unit MODEL 1/2/small MODEL 3. Their adjusting methods are the same as specified above.

Note 3) Don't change the setting of variable resistors other than specified in Table 5.1 (d) and Table 5.1 (e), since these variable resistors have been adjusted at factory before shipment.

For adjustments of variable resistors, see APPENDIX 8.

5.2 Setting and Adjustment of Spindle Orientation Control Circuit Option

Refer to spindle orientation control circuit, in chapter 7.

6. EXCHANGE METHODS OF FUSES AND PCB

6.1 Exchange of Fuses

Replace fuses F1 - F7 in AC SPINDLE SERVO UNIT series after opening the unit cover as shown in 6.1.

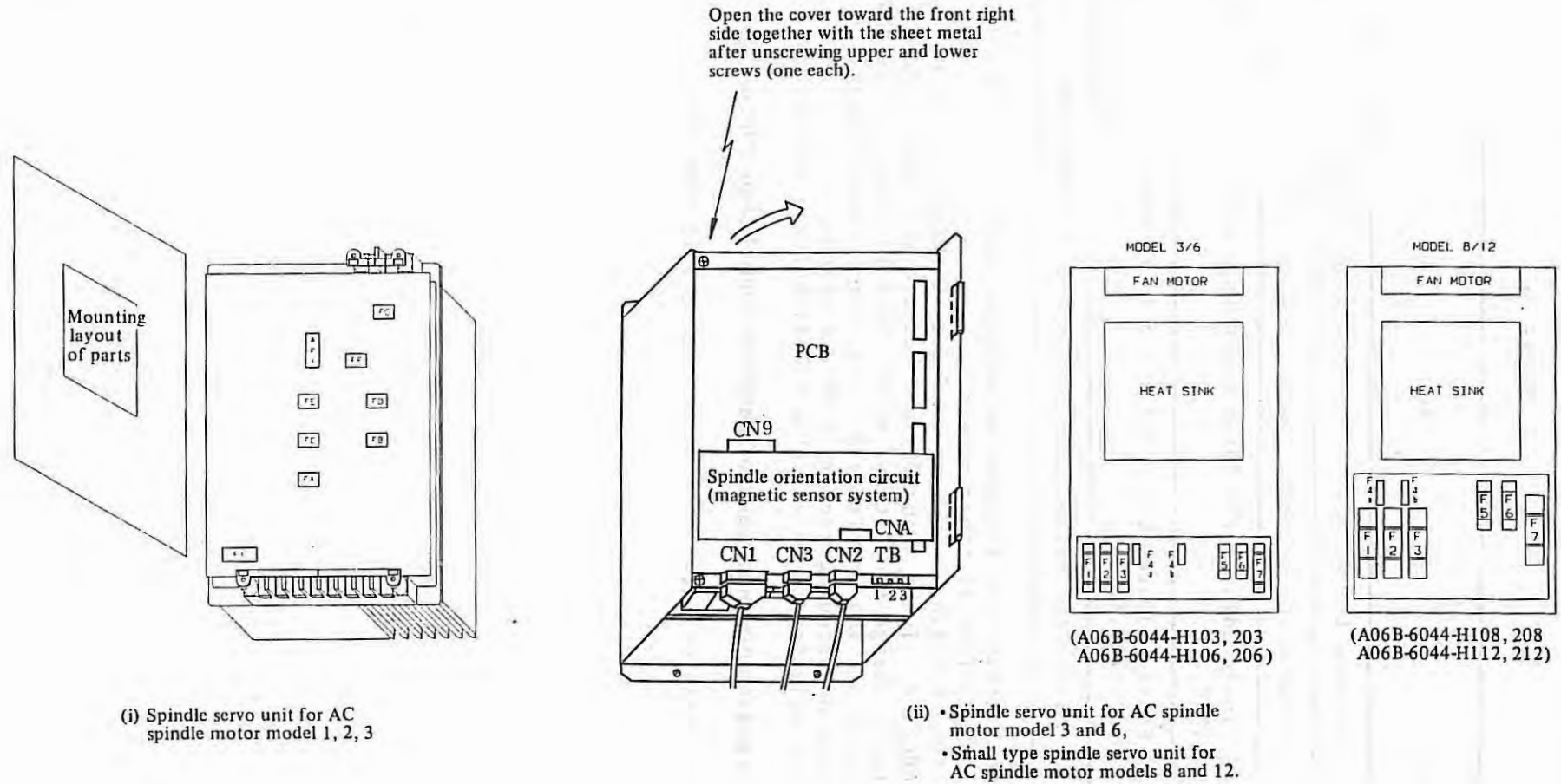
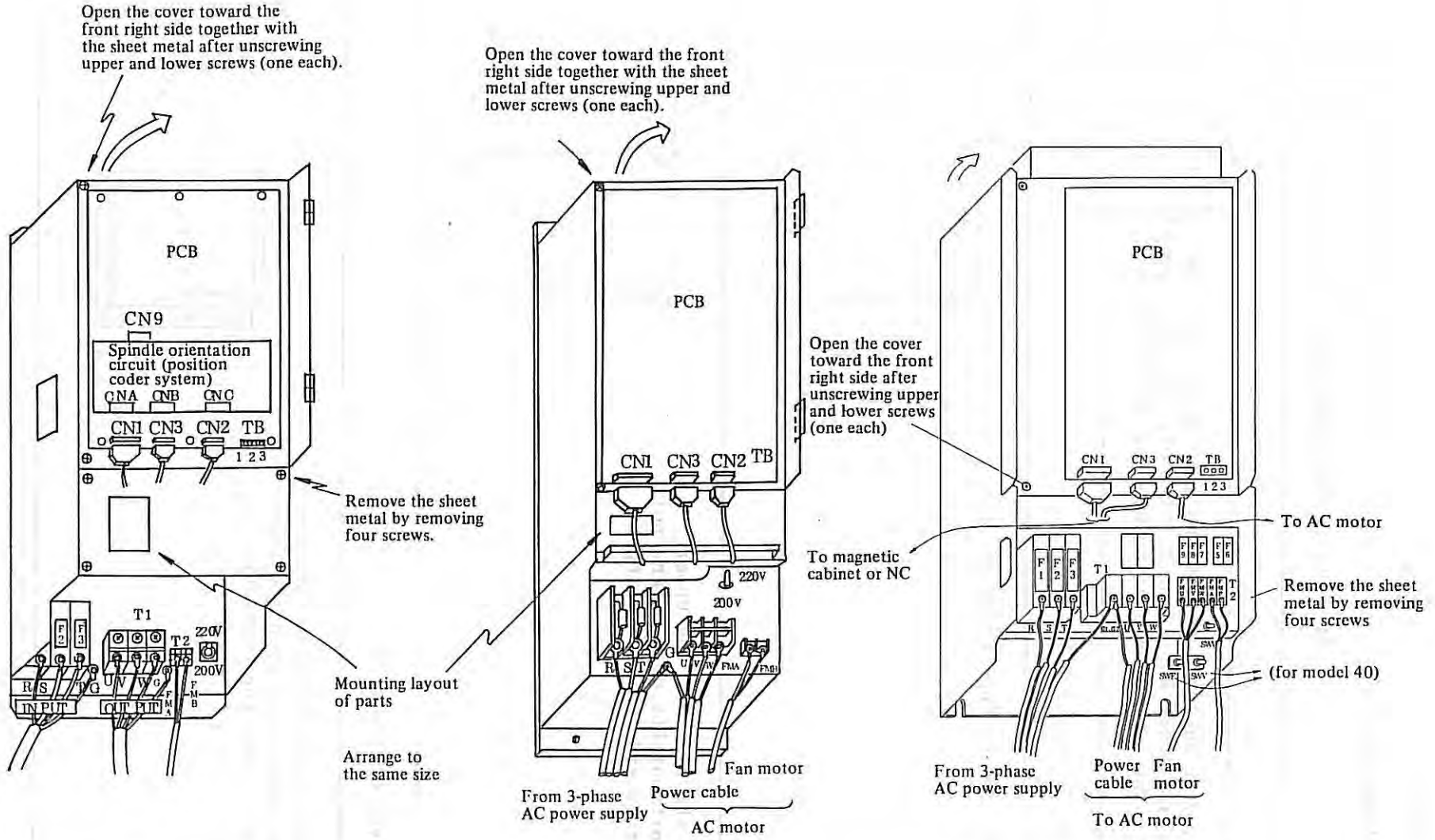

Fig. 6.1 How to open the AC SPINDLE SERVO UNIT series cover (1/2)



(iii) Spindle servo unit for AC spindle motor model 8, 12 and 15
(A06B-6044-H009, H010, H011, H023)

(iv) Spindle servo unit for AC spindle motor models 18 and 22

(v) Spindle servo unit for AC spindle motor model 30 and 40.

Fig. 6.1 How to open the AC SPINDLE SERVO UNIT series cover (2/2)

6.2 Exchange of PCB

6.2.1 MODEL 1/2/small MODEL 3

Table 6.2.1 (a) How to remove PCB

Step	Procedure
1	Disconnect cables from PCB and also disconnect cables which fix the upper and lower PCB after turning off the power supply. Record the correspondence between cables and connector numbers.

Removal of upper PCB

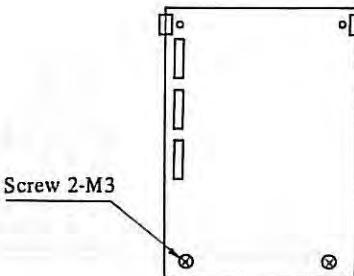
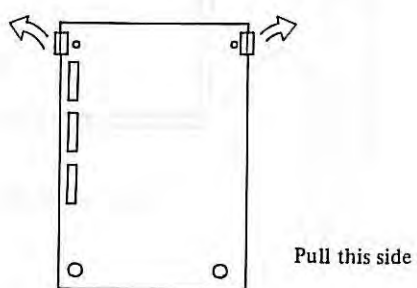
2-1	Remove two fixing screws of PCB. 
2-2	Open the claws of the upper supports of PCB outward and pull PCB this side while lifting it. 

Removal of lower PCB

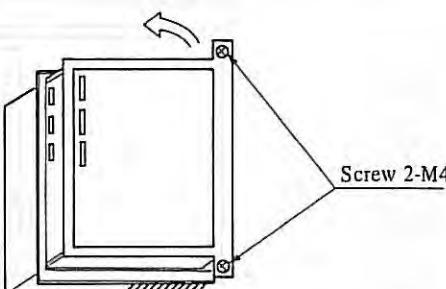
3-1	Remove one upper screw and one lower screw, and open the PCB together with the mounting plate. 
-----	---

Removal of lower PCB

<p>3-2</p>	<p>Remove 28 screws on PCB and remove PCB by pulling this side.</p>	
------------	---	--

Table 6.2.1 (b) How to mount PCB

Step	Procedure
<p>Mounting of upper PCB</p>	
<p>1-1</p>	<p>Set the upper holes of PCB to the upper supports of the mounting plate, and push PCB until a click is heard.</p> 
<p>1-2</p>	<p>Fix the lower part of PCB by 2 screws.</p> 

Mounting of lower PCB

<p>2-1</p>	<p>Insert PCB while setting PCB holes to the conduits mounted from the short bar holder, and fix it by 28 screws.</p>	
<p>2-2</p>	<p>Fix PCB together with its mounting plate to the unit by fixing the upper and lower screws.</p>	
<p>3</p>	<p>Connect cables to the connectors.</p>	
<p>4</p>	<p>Check the ROM specification, PCB setting, and start operation.</p>	

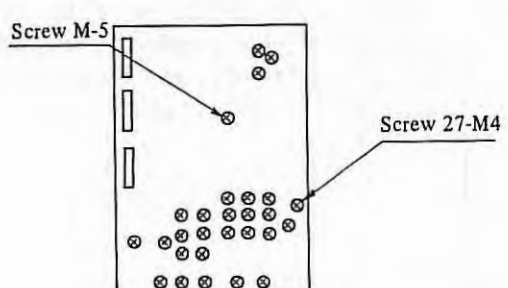
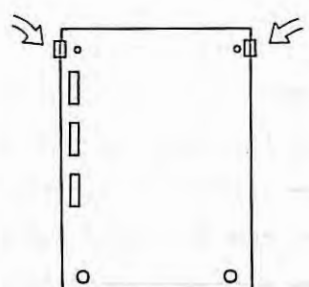
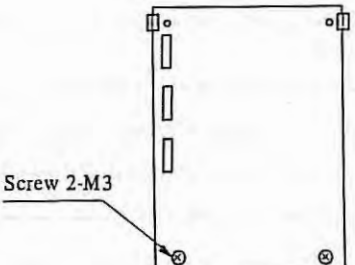
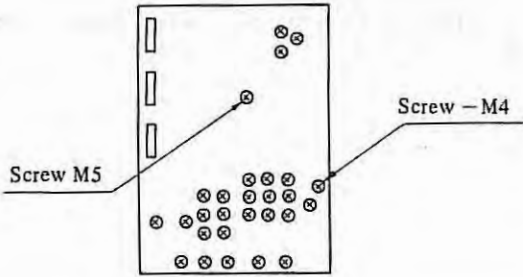
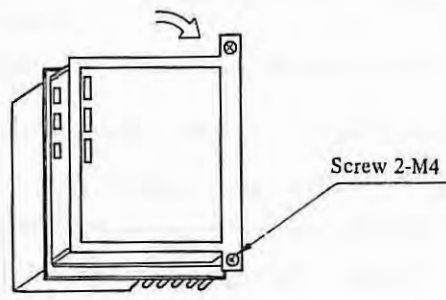
6.2.2 MODEL 3~40

Table 6.2.2 (a) How to remove PCB

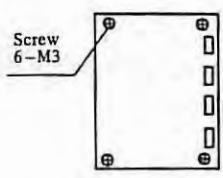
Step	Procedure
<p>1</p>	<p>Disconnect cables from PCB after turning off power supply. Record the correspondence between cables and connector No.</p>
<p>2</p>	<p>Remove six screws fixing PCB.</p> 

Step	Procedure
3	<p>Gradually lift the upper right and lower right part of PCB forward at a time, and remove PCB by disconnecting connectors CN4 - 7 (pins are inserted from the rear side).</p> 

Table 6.2.2 (b) How to mount PCB

Step	Procedure
1	<p>After setting the guide holes of PCB connectors CN4 - 7 to the guide pins on the unit side and insert CN4 - 7 until check groove (see right figure) appears on the PCB connector surface.</p> 
2	Fix PCB on the unit by using four screws. See step 2 in Table 6.2.2 (a).
3	Connect cables to the connectors.
4	Start operating the unit after confirming the ROM specification and PCB setting.

6.3 Exchange of Spindle Orientation Control Circuit PCB

6.3.1 MODEL 1/2/small MODEL 3

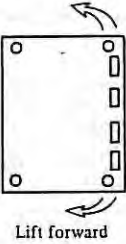
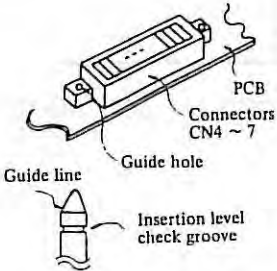
Table 6.3.1 How to remove PCB

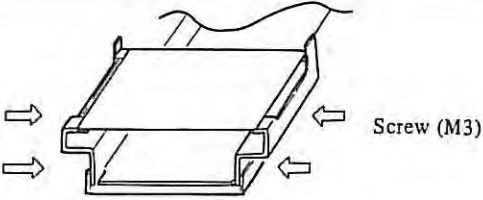
Step	Procedure
1	Disconnect the flat cable which connects PCBs.
2	<p>Remove four screws which fix the spindle orientation control circuit PCB plate.</p> 

6.3.2 MODEL 3 ~ 40

Table 6.3.2 How to remove PCB

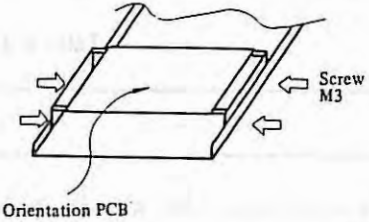
Step	Procedure
1	Remove the entire PCB from the spindle control unit according to Table 6.2.2 (a) disconnect cables connection PCB.
2	<p>Remove 4 screws which fix the stays of spindle orientation control circuit PCB.</p> 

Mount PCB by reversing the procedure specified in Table 6.3.2.

7. SPINDLE ORIENTATION CONTROL CIRCUIT

This chapter describes instructions for maintenance, installation, and adjustment when a pure electric orientation (constant position stop) function is attached to the spindle of an NC machine tool.

7.1 Configuration

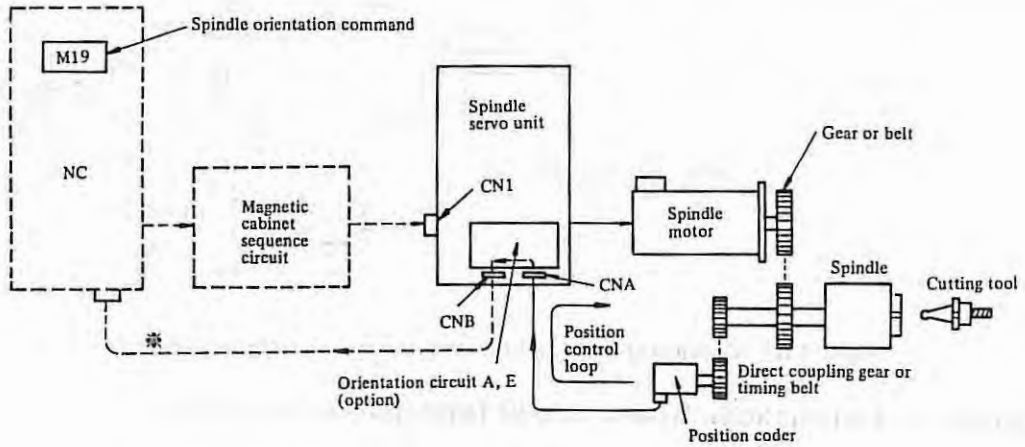

Fig. 7.1 (a) Configuration of spindle orientation using position coder (Internal stop position setting type)

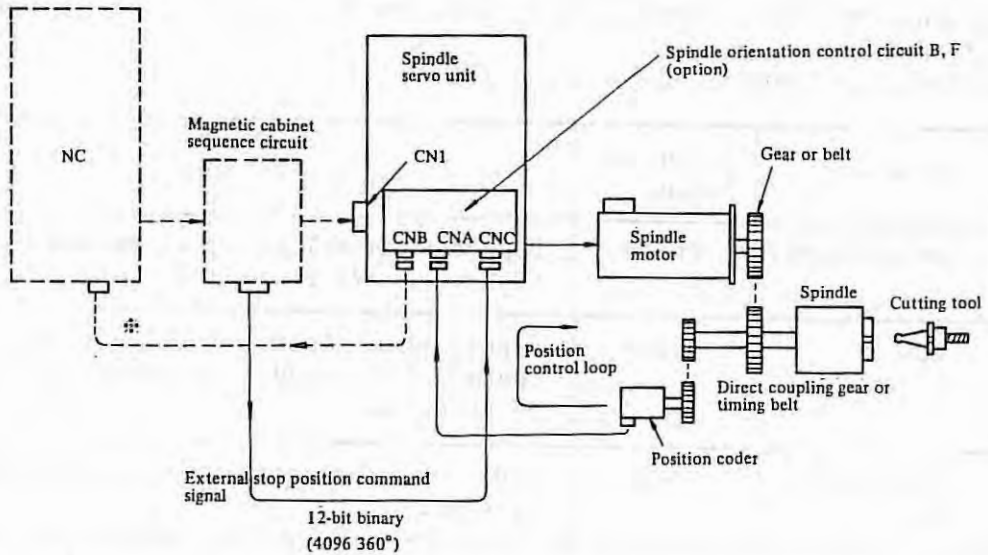

Fig. 7.1 (b) Configuration of spindle orientation using position coder (External stop position setting type)

Note 1) If a position coder is mounted on a lathe, etc., it is applicable to this system.

Note 2) Asterisked cable route is employed when the position coder of the lathe or sync. feed position coder in machining center is combined.

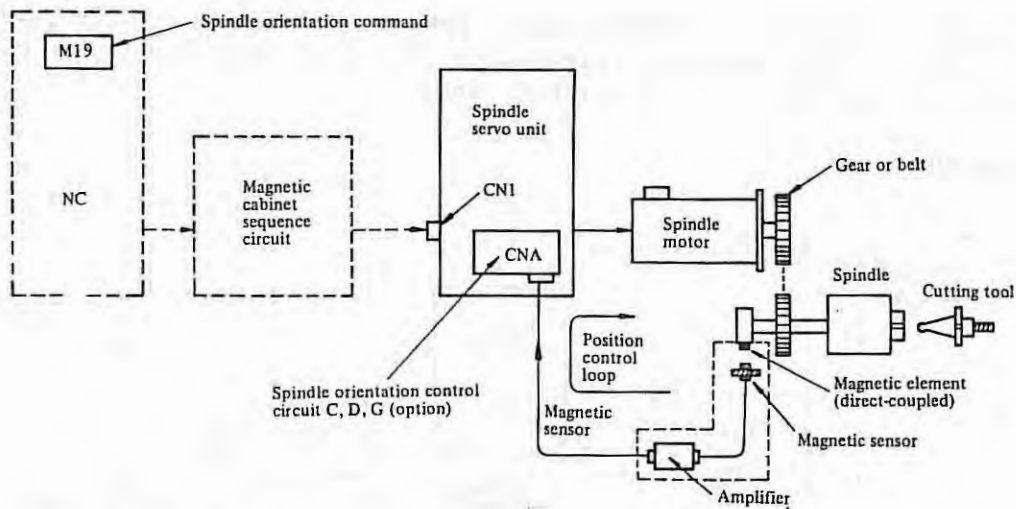

Fig. 7.1 (c) Configuration of spindle orientation using magnetic sensor

7.2 Adjustment of Position Coder System Spindle Orientation Control Circuit

7.2.1 Setting and adjustment of spindle orientation control circuit in 2-step spindle speed change

The MODEL 3~40 require orientation A, B (A06B-6041-J110, J111), while MODEL 1/2/small MODEL 3 require orientation AS or BS (A06B-6052-J110, J111). Setting and adjustment for PCB A20B-0008-0240, 0241 are described in the followings.

1) Display contents

The following display is done using LED.

LED No.	Symbol	Lighting color	Description
LED 1	ORIENTATION	Green	Lights when orientation command (ORCM1, 2 ON) is input.
LED 2	LOW	Green	Lights when clutch switching signal *CTH contact is closed. It means that clutch LOW is selected.
LED 3	IN-POSITION OUT	Green	Light when orientation end signal ORAR1-2 is sent.
LED 4	IN-POSITION ADJUST	Green	Lights when spindle enters within 1 pulse width of orientation command position. Adjust OFFSET adjusting RV3/RV5 so that this LED4 lights at gear HIGH/LOW, and the stop positions at gear HIGH and LOW coincide with each other.

2) Setting

a) Setting position coder power supply

If the position coder power supply +5 V is supplied from the spindle amplifier, short the circuit between +5 V - 5 H and 0 G - 0 V. Open the circuit between +5 V - 5 H and 0 G - 0 V when +5 V is supplied from NC machine tool.

b) Setting of SW4 and SW5

Position coder	Type	SW4	SW5
Balanced type	Type A	Right	Right
Unbalanced type	Type B	Left	Left

c) Setting of SH01, SH02, SH03

Set SH01, SH02, and SH03 according to the following table.

Table 7.2.1 Setting of SH01, SH02 and SH03

O indicates short-circuit, while
× indicates opening.

No.	Setting contents		SH01								SH02								SH03			Remarks
			1	2	3	4	5	6	7	8	1	2	3	4	5	6	7	8	1	2		
			16	15	14	13	12	11	10	9	16	15	14	13	12	11	10	9	2	3		
1	Setting of rotating direction in the first orientation after turning on the power switch.	CCW	O	×																(Standard)		
		CW	×	O																		
2	Setting of rotating direction in the second and subsequent orientation.	CCW direction only			×	O														(Standard)		
		CW direction only			×	×																
		Same as rotating direction			O	×														(Standard)		
3	Setting to clamp the orientation speed determined by position gain to 1, 2/3 and 1/3.	1				×	×															
		2/3					O	×														
		1/3					×	O														
4	Setting by spindle rotation and rotating direction of position coder.	Same direction							O	×										Depens upon machine tools. Hunting occurs, if this setting is inverted.		
		Opposite direction							×	O												
5	Setting of the in-position width when orientation end signals (ORAR1, 2) are output.	+2 pulse									O	O	O	O	O	O				(+16 pulse corresponds to +1.3°)		
		+4										O	O	O	O	O						
		+8											O	O	O	O						
		+16												O	O	O						
		+32													O	O						
		+64														O						
6	Setting by hysteresis of position coder	No compensation															×	×	(Standard)			
		+1 pulse															O	×				
		-1 pulse																×	O			
7	Setting according to the types of spindle servo unit.	DC																O	×	When DC spindle servo unit is used.		
		AC																	×	O	When AC spindle servo unit is used.	

(Note) Sending condition (C) of orientation end signal are as below:

- * The angle position is located with the in-position setting pulse range.
- * Speed zero signal is turned on.
- * ORCM is turned on.

d) Setting of position switches (SW1, 2, 3)

Setting switch	Pulse number per 1 division	Angle change amount per 1 division
SW1	$4096/16 = 256$ pulses	every 22.5°
SW2	$256/16 = 16$ pulses	every 1.4°
SW3	$16/16 = 1$ pulse	every 0.088°

SW1 to SW3 are digital switch with 16 scale.

The spindle can be stopped at an optional point during one rotation in the unit of $1/4096 \times 360^\circ = 0.088^\circ$ by setting these switches in the order of SW1, SW2, SW3.

3) Adjustments

No.	Item	Name of variable resistor	Standard adjustment	Measuring point	Description
1	Speed feedback voltage OFFSET	RV1	5 divisions	TSA2 CH14 (TSA2)	Adjust RV1 until TSA2 voltage becomes 0 ± 1 mV.
2	Gear HIGH position gain	RV2	3 - 4 divisions	Spindle motion or CH14	Set the gain to the maximum within a range where the spindle does not overshoot.
3	Gear HIGH offset	RV3	About 5 divisions	LED4 (ADJUST)	Adjust RV3 until LED4 lights or flickers.
4	Gear LOW position gain	RV4	3 - 6 divisions	Spindle motion or CH14	Set the gain to the maximum within a range where the spindle does not overshoot.
5	Gear LOW offset	RV5	About 5 divisions	LED4 (ADJUST)	Adjust RV5 until LED4 lights or flickers.
6	Speed loop gain (in case of DC spindle motor)	RV6DC	0 division	CH14	Make sure that motor not hunting. the rigidity increases during stop by turning these RV clock-wise.
7	Speed loop gain (in case of AC spindle motor)	RV6AC	7 divisions	CH14	

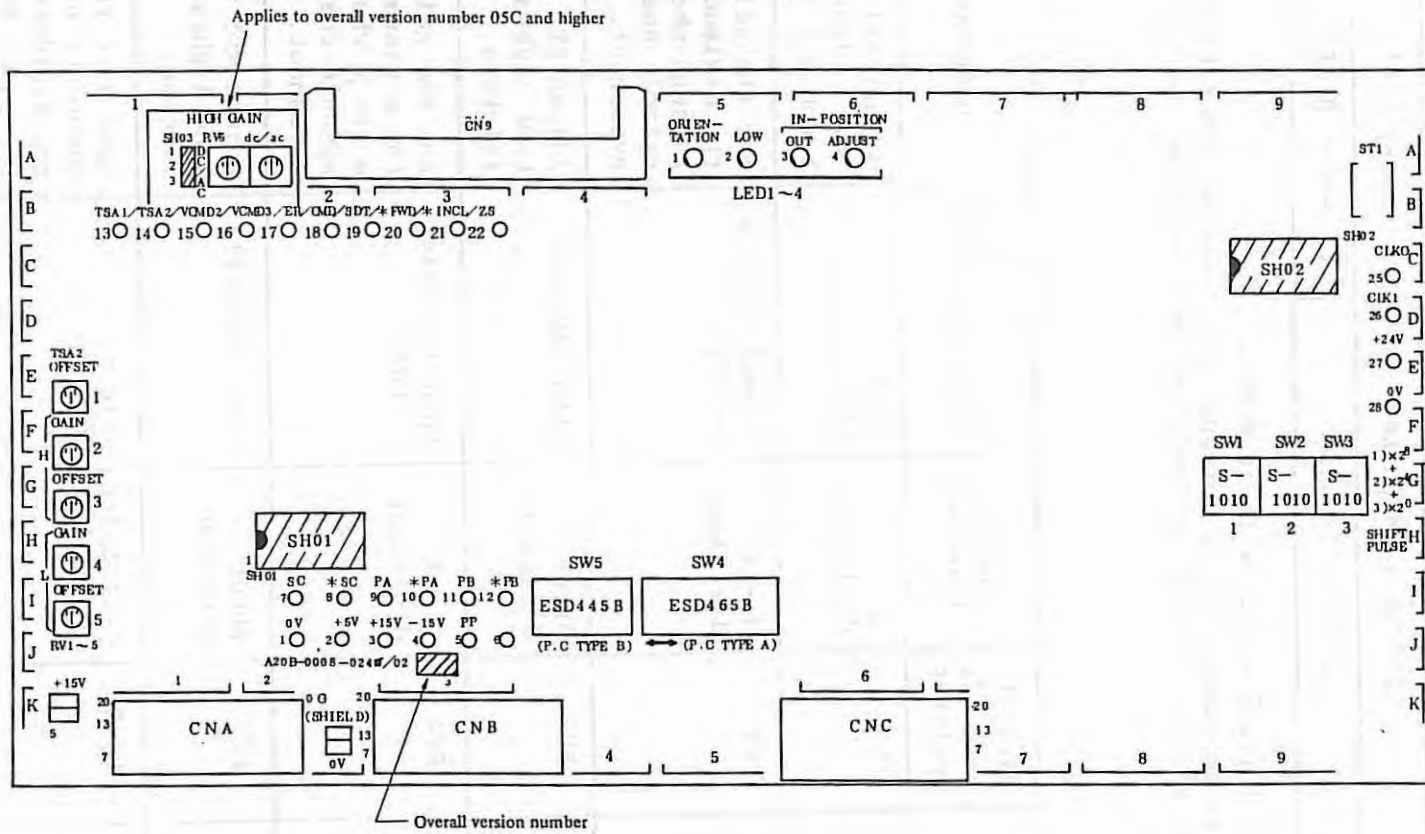

Fig. 7.2.1 (a) Mounting positions of check terminals, variable resistors, setting pins, and light-emitting diodes (LED) (PCB A20B-0008-0240, 0241)

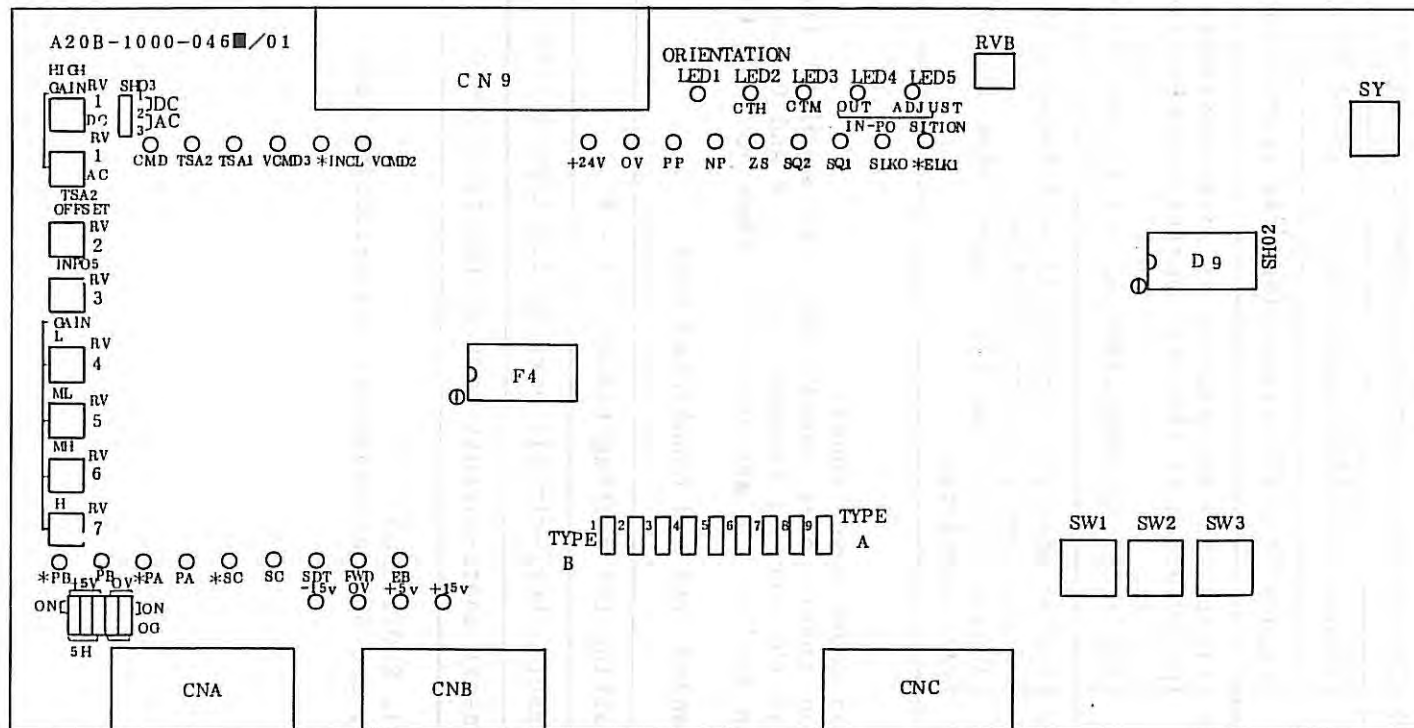

Fig. 7.2.1 (b) Mounting place of check terminal, variable register, setting pin, LED (PCB A20b-1000-0460, 0461)

7.2.2 Setting and adjustment for spindle orientation control circuit 3 or 4 step spindle speed change

Orientation E, F (A06B-6041-J130, J131) are required. Setting and adjustments for the PCB A20B-1000-0460, 0461 are described in the followings.

1) Display contents

LED No.	Symbol	Description
LED1	ORIENTATION	Lights when orientation command is input.
LED2	CTH	Lights when CTH signal (spindle speed change) is input.
LED3	CTM	Lights when CTM signal (spindle speed change) is input.
LED4	IN-POSITION OUT	Lights when the machine is positioned within the setting pulse width of the stop position after orientation motion. The stop position width is set by SH02 01-06 pins.
LED5	IN-POSITION ADJUST	Lights when the machine is positioned within <u>+2</u> pulses of the specified stop position. Adjust RV3 so that LED5 lights when the orientation has been completed.

2) Setting

a) Setting position coder power supply

If the position coder power supply +5 V is supplied from the spindle amplifier, short the circuit between +5 V - 5 H and 0 G - 0 V. Open the circuit between +5 V - 5 H and 0 G - 0 V when +5 V is supplied from NC machine tool.

b) Setting of balanced type and unbalanced type

Position coder	Setting for setting terminal 1 - 9
Balanced type	Insert short-circuit bars on the type A side (9 positions)
Unbalanced type	Insert short-circuit bars on the type B side (9 positions)

c) Setting of SH01, SH02, SH03

Set SH01, SH02, and SH03 according to the following table.

Table 7.2.2 Setting of SH01, SH02 and SH03

O indicates short-circuit, while
× indicates opening.

No.	Setting contents	SH01								SH02								SH03		Remarks	
		1	2	3	4	5	6	7	8	1	2	3	4	5	6	7	8	1	2		
		16	15	14	13	12	11	10	9	16	15	14	13	12	11	10	9	2	3		
1	Setting of rotating direction in the first orientation after turning on the power switch.	CCW	O	×																(Standard)	
	CW	×	O																		
2	Setting of rotating direction in the second and subsequent orientation.	CCW direction only			×	O														(Standard)	
		CW direction only			×	×															
		Same as rotating direction			O	×															(Standard)
3	Setting to clamp the orientation speed determined by position gain to 1, 2/3 and 1/3.	1				×	×														
		2/3					O	×													
		1/3					×	O													
4	Setting by spindle rotation and rotating direction of position coder.	Same direction						O	×											Depens upon machine tools. Hunting occurs, if this setting is inverted.	
		Opposite direction						×	O												
5	Setting of the in-position width when orientation end signals (ORAR1, 2) are output.	+2 pulse								O	O	O	O	O	O					(+16 pulse corresponds to +1.3°)	
		+4									O	O	O	O	O						
		+8										O	O	O	O						
		+16											O	O	O						
		+32													O	O					
		+64														O					
6	Setting by hysteresis of position coder	No compensation														×	×			(Standard)	
		+1 pulse														O	×				
		-1 pulse															×	O			
7	Setting according to the types of spindle servo unit.	DC															O	×		When DC spindle servo unit is used.	
		AC																×	O		When AC spindle servo unit is used.

(Note) Sending condition (C) of orientation end signal are as below:

- * The angle position is located with the in-position setting pulse range.
- * Speed zero signal is turned on.
- * ORCM is turned on.

d) Setting of position switches (SW1, 2, 3)

Setting switch	Pulse number per 1 division	Angle change amount per 1 division
SW1	$4096/16 = 256$ pulses	every 22.5°
SW2	$256/16 = 16$ pulses	every 1.4°
SW3	$16/16 = 1$ pulse	every 0.088°

The spindle can be stopped at an optional point during one rotation in the unit of $1/4096 \times 360^\circ = 0.088^\circ$ by setting these switches in the order of SW1, SW2, SW3.

3) Adjustment

No.	Item	Name of variable resistor	Standard adjusting Value	Measuring point	Description
1	Orientation high gain	RV1 DC (for DC motor)	0 division		Rigidity increases when turning clockwise during stop.
2	Orientation high gain	RV1A AC (for AC motor)	7 divisions		
3	Velocity feedback voltage offset	RV2	5 divisions	TSA2	Adjust until the voltage becomes 0 ± 1 mV when the spindle is stopping.
4	Fine position adjustment	RV3	5 divisions	VCMD3	Adjust so that LED5 (ADJUST) lights at high gear position gain.
5	Low gear position gain CTH-ON.CTM-ON	RV4	2 divisions	Spindle motion (TSA2)	Set the gain to the maximum within a range where the spindle does not overshoot.
6	M. Low gear position gain CTH-ON.CTM-OFF	RV5	2 divisions	Spindle motion (TSA2)	Set the gain to the maximum within a range where the spindle does not overshoot.
7	M. Low gear position gain CTH-OFF.CTM-ON	RV6	2 divisions	Spindle motion (TSA2)	Set the gain to the maximum within a range where the spindle does not overshoot.
8	High gear position gain CTH-OFF.CTM-OFF	RV7	2 division	Spindle motion (TSA2)	Set the gain to the maximum within a range where the spindle does not overshoot.

No.	Item	Name of variable resistor	Standard adjusting value	Measuring point	Description
9	ER voltage offset adjustment	RV8	0 \pm 1 mV	ER	Adjusted before delivery.
		Note) 1. Set SW1 - 3 as follows. SW1 ... 8 divisions, SW2, SW3 ... 0 division 2. Set No. 1 - 4 setting pins (type A/B) to OFF. 3. Perform the above adjustments after motor has been rotating with the orientation command turned on.			

7.3 Adjustment of Magnetic Sensor Type Spindle Orientation Control Circuit

7.3.1 Mounting method of magnetizing element and magnetic sensor

Determine the mounting directions of the magnetizing element and magnetic sensor according to the following procedure. If they are not mounted correctly, the spindle may repeat normal rotation and reverse rotation without being stopped, the hunting occurs, or the spindle stops at the position where the magnetizing element end is opposite to the sensor head.

Mounting procedure of magnetizing element and magnetic sensor

Item	Procedure
1	Mount the magnetizing element is such a way as the reference hole faces as shown in Fig. 7.3.1 when the spindle is turned by the spindle motor normal rotation command (SFR, VCMD: Positive).
2	Mount the magnetic sensor head so that the pin hole of the flange is opposite to the reference hole.
3	Adjust the gap between the magnetizing element and the sensor head, so that the minimum gap value L becomes $L = 1.5 \pm 0.5$ mm.

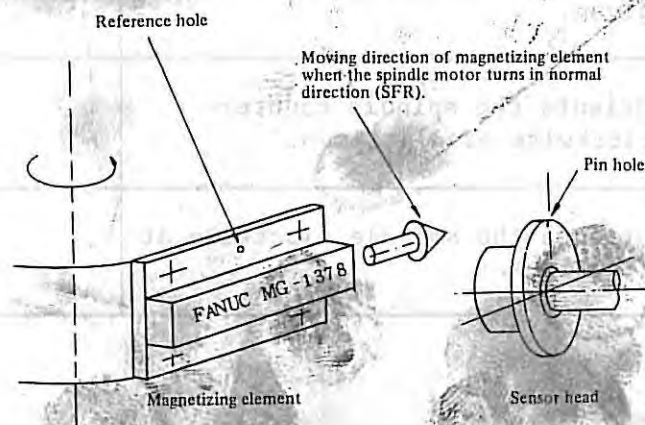

Fig. 7.3.1 (a) Mounting direction of magnetizing element (Reference drawing)

7.3.2 Setting and adjustment of spindle orientation control circuit in 2-step speed change spindle for standard type

The MODEL 3 to 40 require the orientation C (A06B-6041-J120), while MODEL 1/2/small MODEL 3 require orientation C (A06B-6052-J120), (PCB A20B-0008-0030) is used. This circuit is set and adjusted as follows.

1) Setting and adjustment of setting terminals (SH)

Table 7.3.2 (a) shows the setting and functions of setting terminal (SH). Select these terminals by user.

Terminal SH01 is provided for adjustment and testing at site. Set this SH01 terminal after turning on the power supply, and disconnect it after adjustment without fail.

(Make sure that LED7 goes out).

Table 7.3.2 (a) Setting and functions of setting terminals (SH)

			Setting and functions of setting terminals (SH) (The double frame indicates standard setting)	
Setting (Note 1)			Function	Remarks
SH	1-2	2-3		
01		o	Sets the test model. (Note 2)	Set for adjustment only.
02	o	x	Rotates the motor shaft end clockwise when the orientation command is given before operating the spindle after turning on the power supply.	SH03 setting takes precedence of SH02. This is effective only when SH03: 1-2 are shorted.
	<input checked="" type="checkbox"/>	o	Rotates ----- counterclockwise	
03	<input checked="" type="checkbox"/>	x	Orients in the direction the spindle was turning just before the orientation command was given.	SH02 setting becomes effective.
	x	o	Orients the spindle counterclockwise at all times.	
	x	x	Orients the spindle clockwise at all times.	

Setting (Note 1)			Function	Remarks
SH	1-2	2-3		
04	x	x	Sets the initial orientation speed to about 60 (spindle position loop gain sec^{-1}) of the spindle.	Since the position loop gain of spindle is 5 sec^{-1} in general, the initial speed is about 300 rpm without limitation.
	o	x	Limits the initial orientation speed to 1/3.	
	x	o	Limits the initial orientation speed to 2/3.	
05	o	x	For DC spindle servo unit.	
	x	o	For AC spindle servo unit.	

Note 1) o indicates short-circuit, while x indicates opening.

Note 2) Method of setting the TEST MODE.

(1) Turn on spindle orientation command.

(2) Spindle orientation end signal (ORAR1, 2) is not sent.

(3) The spindle turns at the initial orientation speed, while the SW1 (INITIALIZING BUTTON) is being depressed and the spindle stops at the fixed position when SW1 is released.)

(4) Red LED7 lights in this mode.

2) LED display contents

Seven indicator lamps LED1 - 7 are mounted on spindle orientation control circuit C PCB. The following table shows their display contents. Neither LED1 nor LED2 is mounted on PCB of 01A version.

LED display contents			
LED	Display contents	Lighting color	Description
1	ORIENTATION (Orientation in progress)	Green	Lights when spindle orientation command is given (ORCM1 and 2 are shorted).
2	LOW (Clutch (gear) LOW)	Green	Lights when clutch (gear) LOW signal is turned on (*CTH1 and 2 are shorted).
3	MS PEAK LEVEL (Magnetic flux detection signal peak value adjusting indicator)	Green	This adjusting indicator lights when the peak value of the magnetic flux detection signal (MS) exceeds <u>+10 V.</u>

LED display contents

LED	Display contents	Lighting color	Description
4	SLOWDOWN PERIOD (Low-speed rotation period adjusting indicator)	Green	Lights when the spindle approaches the stop position and enters the low speed rotation area during spindle orientation motion.
5	IN POSITION FINE (In-position adjusting indicator)	Green	Lights when the magnetic flux signal (output) value is within the setting range of 0.1° as a converted spindle angle. This LED5 may also light when the sensor is not positioned on the magnetizing element.
6	IN-POSITION (In-position in progress)	Green	Lights when the spindle is within +1° of the aimed adjusting position after completion of spindle orientation. The spindle orientation end signal (ORAR1 and 2 are shorted) is sent when this LED is lighting in a mode other than TEST mode.
7	TEST MODE (Test mode in progress)	Red	Lights when setting terminal SH01 pins are shorted. The orientation end signal is not sent in this mode even if the orientation motion is executed.

3) Setting of variable resistors

Set the variable resistor scale as shown in the following table before starting adjustments.

Asterisked items are readjusted during adjustment procedure described later. Set these items also as the preliminary setting.

Setting and preparation of variable resistors

Name of variable resistor	RV	1*	2*	3	4	5	6*	7*	8	9*	10*	11*	12DC	12AC
Variable resistor scale position		5.0	6.0	①	①	②	2.0	5.0	③	2.0	5.0	5.0	0	7.0

① Setting of RV3 and RV4

Set RV3 and RV4 according to the distance H between the rotation center line of magnetizing element and the center of the sencer head face.

H (mm)	60~65	~70	~75	~80	~85	~90	~95	~100	~105	~110
Scale position	7.0	6.0	5.0	4.0	3.0	2.5	2.0	1.5	1.0	0.5

② Setting of RV5

Set RV5 according to the spindle HIGH revolutions N_{HM} when the spindle motor turns at the rated revolutions.

N_{HM} (rpm)	2,000 ~ 2,200	~ 2,500	~ 2,700	~ 3,100	~ 3,500	~ 4,000	~ 4,500	~ 5,000	~ 5,500	~ 6,000
Scale position	7.5	6.5	5.5	4.5	3.5	2.5	2.0	1.5	1.0	0.5

③ Setting of RV8

Set RV8 according to the spindle HIGH/LOW reduction gear ratio $R_{H/L}$.

$R_{H/L}$	-2.0	-2.2	-2.5	-2.8	-3.2	-3.7	-4.4	-5.3	-6.0	-7.0
Scale position	2.0	3.0	4.0	5.0	6.0	7.0	8.0	9.0	9.5	10

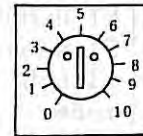

Variable resistor scale

4) Adjustment of variable resistors

Adjust RV1 - 12, 12DC, and 12AC according to the following table. Adjust the offset and gain of spindle control circuit PCB before adjusting the orientation circuit. When RV12 and RV13 of the spindle control circuit PCB are changed, the stop position may be deviated.

Table 7.3.2 (b) Adjustments of variable resistors

Set the test mode for the following adjustments by shorting SH01 pins.

Item	Name of variable resistor	Item to be adjusted	Conditions	Adjusting method (specification)
1	RV1	TS OFFSET Tachogenerator offset. (Compensation for the difference of the slow down time in normal and reverse rotating direction)	Compare the slow down time during the orientation in normal and reverse directions after completion of this adjustments.	The standard setting value is 5 divisions. Adjust RV1 until the difference of the slow down time between normal and reverse rotation become shorter than 0.1 sec.
2	RV2	MS PEAK LEVEL MS signal amplitude value.	Keep depressing SW1 (initializing button).	Set VR2 to the position where LED3 (MS PEAK LEVEL) starts flickering.
3	RV3	SLOWDOWN REFERENCE Slowdown speed reference.		See 7.3.2 (3) 1 .
4	RV4	AMS PEAK LEVEL AMS signal amplitude value.		See 7.3.2 (3) 1 .
5	RV5	SLOWDOWN TIME IN HIGH MODE Slowdown time in clutch (gear) high mode.	Set the clutch (gear) HIGH mode. Stop the spindle at the fixed position by depressing SW1 once. *CTH signal is OFF (option).	LED4 (SLOWDOWN PERIOD) should clearly light at a moment just before the spindle stops.
6	RV6	GAIN (H) Position loop gain.	Same as specified above.	Turn RV6 clockwise to such an extent as does not cause any overshoot when the spindle stops.
7	RV7	IN-POSITION (H) Spindle stop position (H).	Same as specified above.	LED5 (IN-POS FINE) should light during lighting of LED6 (IN-POSITION).
8	RV8	SLOWDOWN TIME IN LOW MODE Slowdown the in clutch (gear) low mode.	Set the clutch (gear) LOW mode. Stop the spindle at the fixed position by depressing SW1 once. *CTH signal is turned on (closed).	LED (SLOWDOWN PERIOD) should clearly light at a moment just before the spindle stops. (See item 5 in this table.)

Item	Name of variable resistor	Item to be adjusted	Conditions	Adjusting method (specification)
9	RV9	GAIN (L) Position loop gain.	Same as specified above.	Turn RV9 clockwise to such an extent as does not cause any overshoot when the spindle stops.
10	RV10	IN-POSITION (L) Spindle stop position (L).	Same as specified above.	LED5 (IN-POS FINE) should light during lighting of LED6 (IN-POSITION).
11	RV11	POSITION SHIFT Spindle stop position shift.		The spindle stop position can be finely adjusted within a range $\pm 1^\circ$ the spindle angle.
12	RV12 DC	HIGH GAIN DC High gain.	Adjust RV12 when DC spindle servo unit is used.	Standard adjusting value: 7 divisions.
13	RV12 AC	HIGH GAIN AC High gain.	Adjust RV12 when AC spindle servo unit is used.	Standard adjusting value: 7 divisions.

After adjustments, cancel the test mode, and make sure that the LED7 (red) goes out.

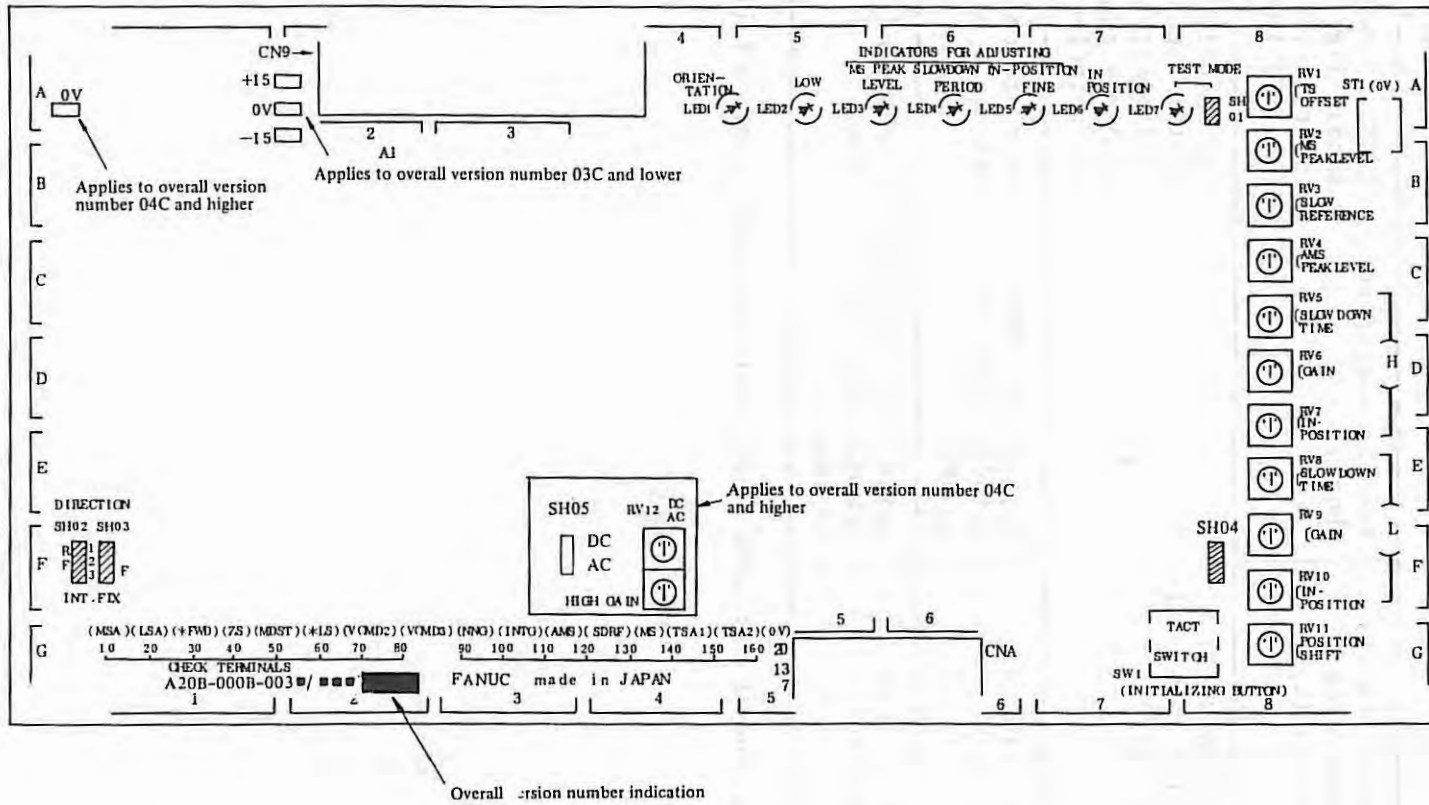

Fig. 7.3.2 Mounting positions of check terminals, variable resistors, setting pins and light-emitting diodes (LED) (PCB A20B-0008-0030)

7.3.3 Setting and adjustment of spindle orientation control circuit in 2-step spindle speed for high speed

The MODEL 3 to 40 require the orientation G (A06B-6041-J122), while MODEL 1/2/small MODEL 3 require orientation GS (A06B-6052-J122), (PCB A20B-0008-0031) is used. This circuit is set and adjusted as follows.

1) Setting and adjustment of setting terminals (SH)

Table 7.3.3 (a) shows the setting and functions of setting terminal (SH). Select these terminals by user.

Terminal SH01 is provided for adjustment and testing at site. Set this SH01 terminal after turning on the power supply, and disconnect it after adjustment without fail.

(Make sure that LED7 goes out).

Table 7.3.3 (a) Setting and functions of setting terminals (SH)

			Setting and functions of setting terminals (SH) (The double frame indicates standard setting)	
Setting (Note 1)			Function	Remarks
SH	1-2	2-3		
01		o	Sets the test model. (Note 2)	Set for adjustment only.
02	o	x	Rotates the motor shaft end clockwise when the orientation command is given before operating the spindle after turning on the power supply.	SH03 setting takes precedence of SH02. This is effective only when SH03: 1-2 are shorted.
	x	o	Rotates ----- counterclockwise	
03	o	x	Orients in the direction the spindle was turning just before the orientation command was given.	SH02 setting becomes effective.
	x	o	Orients the spindle counterclockwise at all times.	
	x	x	Orients the spindle clockwise at all times.	

Setting (Note 1)			Function	Remarks
SH	1-2	2-3		
04	x	x	Sets the initial orientation speed to about 60 (spindle position loop gain sec^{-1}) of the spindle.	Since the position loop gain of spindle is 5 sec^{-1} in general, the initial speed is about 300 rpm without limitation.
	o	x	Limits the initial orientation speed to 1/3.	
	x	o	Limits the initial orientation speed to 2/3.	
05	o	x	For DC spindle servo unit.	
	x	o	For AC spindle servo unit.	

Note 1) o indicates short-circuit, while x indicates opening.

Note 2) Method of setting the TEST MODE.

(1) Turn on spindle orientation command.

(2) Spindle orientation end signal (ORAR1, 2) is not sent.

(3) The spindle turns at the initial orientation speed, while the SW1 (INITIALIZING BUTTON) is being depressed and the spindle stops at the fixed position when SW1 is released.)

(4) Red LED7 lights in this mode.

2) LED display contents

Seven indicator lamps LED1 - 7 are mounted on spindle orientation control circuit G and GS PCB. The following table shows their display contents.

LED display contents

LED	Display contents	Lighting color	Description
1	ORIENTATION (Orientation in progress)	Green	Lights when spindle orientation command is given (ORCM1 and 2 are shorted).
2	LOW (Clutch (gear) LOW)	Green	Lights when clutch (gear) LOW signal is turned on (*CTH1 and 2 are shorted).
3	MS PEAK LEVEL (Magnetic flux detection signal peak value adjusting indicator)	Green	This adjusting indicator lights when the peak value of the magnetic flux detection signal (MS) exceeds <u>+10 V.</u>

LED display contents			
LED	Display contents	Lighting color	Description
4	SLOWDOWN PERIOD (Low-speed rotation period adjusting indicator)	Green	Lights when the spindle approaches the stop position and enters the low speed rotation are a during spindle orientation motion.
5	IN POSITION FINE (In-position adjusting indicator)	Green	Lights when the magnetic flux signal (output) value is within the setting range of 0.1° as a converted spindle angle. This LED5 may also light when the sensor is not positioned on the magnetizing element.
6	IN-POSITION (In-position in progress)	Green	Lights when the spindle is within +1° of the aimed adjusting position after completion of spindle orientation. The spindle orientation end signal (ORAR1 and 2 are shorted) is sent when this LED is lighting in a mode other than TEST mode.
7	TEST MODE (Test mode in progress)	Red	Lights when setting terminal SH01 pins are shorted. The orientation end signal is not sent in this mode even if the orientation motion is executed.

3) Setting of variable resistors

Set the variable resistor scale as shown in the following table before starting adjustments.

Asterisked items are readjusted during adjustment procedure described later. Set these items also as the preliminary setting.

Setting and preparation of variable resistors

Name of variable resistor	RV	1*	2*	3	4	5	6*	7*	8	9*	10*	11*	12DC	12AC
Variable resistor scale position		5.0	5.0	①	①	②	5.0	5.0	③	5.0	5.0	5.0	0	8.0

① Setting of RV3 and RV4

Set RV3 and RV4 according to the distance H between the rotation center line of magnetizing element and the center of the head face.

H (mm)	40~45	~50	~55	~60	~65	~70	~80	~90	~100	~110
Scale position	9.5	7.0	5.0	4.0	3.0	2.5	2.0	1.5	1.0	1.0

② Setting of RV5

Set RV5 according to the spindle HIGH revolutions N_{HM} when the spindle motor turns at the rated revolutions.

N_{HM} (rpm)	6,000 ~ 6,500	~ 7,000	~ 7,500	~ 8,000	~ 8,500	~ 9,000	~ 9,500	~ 10,000	~ 11,000	~ 12,000
Scale position	6.0	5.0	4.5	4.0	3.5	3.0	2.5	2.5	2.0	1.0

③ Setting of RV8

Set RV8 according to the spindle HIGH/LOW reduction gear ratio $R_{H/L}$.

$R_{H/L}$	~2.2	~2.5	~2.8	~3.2	~3.7	~4.5	~5.0	~6.0	~7.0	~
Scale position	2.0	3.0	4.0	5.0	6.0	7.0	8.0	8.0	9.0	

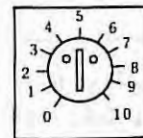

Variable resistor scale

4) Adjustment of variable resistors

Adjust RV1 - 12, 12DC, and 12AC according to the following table. Adjust the offset and gain of spindle control circuit PCB before adjusting the orientation circuit. When RV12 and RV13 of the spindle control circuit PCB are changed, the stop position may be deviated.

Table 7.3.3 (b) Adjustments of variable resistors

Set the test mode for the following adjustments by shorting SH01 pins.

Item	Name of variable resistor	Item to be adjusted	Conditions	Adjusting method (specification)
1	RV1	TS OFFSET Tachogenerator offset. (Compensation for the difference of the slow down time in normal and reverse rotating direction)	Compare the slow down time during the orientation in normal and reverse directions after completion of this adjustments.	The standard setting value is 5 divisions. Adjust RV1 until the difference of the slow down time between normal and reverse rotation become shorter than 0.1 sec.
2	RV2	MS PEAK LEVEL MS signal amplitude value.	Keep depressing SW1 (initializing button).	Set VR2 to the position where LED3 (MS PEAK LEVEL) starts flickering.
3	RV3	SLOWDOWN REFERENCE Slowdown speed reference.		See 7.3.3 (3) 1 .
4	RV4	AMS PEAK LEVEL AMS signal amplitude value.		See 7.3.3 (3) 1 .
5	RV5	SLOWDOWN TIME IN HIGH MODE Slowdown time in clutch (gear) high mode.	Set the clutch (gear) HIGH mode. Stop the spindle at the fixed position by depressing SW1 once. *CTH signal is OFF (option).	LED4 (SLOWDOWN PERIOD) should clearly light at a moment just before the spindle stops.
6	RV6	GAIN (H) Position loop gain.	Same as specified above.	Turn RV6 clockwise to such an extent as does not cause any overshoot when the spindle stops.
7	RV7	IN-POSITION (H) Spindle stop position (H).	Same as specified above.	LED5 (IN-POS FINE) should light during lighting of LED6 (IN-POSITION).
8	RV8	SLOWDOWN TIME IN LOW MODE Slowdown the in clutch (gear) low mode.	Set the clutch (gear) LOW mode. Stop the spindle at the fixed position by depressing SW1 once. *CTH signal is turned on (closed).	LED (SLOWDOWN PERIOD) should clearly light at a moment just before the spindle stops. (See item 5 in this table.)

Item	Name of variable resistor	Item to be adjusted	Conditions	Adjusting method (specification)
9	RV9	GAIN (L) Position loop gain.	Same as specified above.	Turn RV9 clockwise to such an extent as does not cause any overshoot when the spindle stops.
10	RV10	IN-POSITION (L) Spindle stop position (L).	Same as specified above.	LED5 (IN-POS FINE) should light during lighting of LED6 (IN-POSITION).
11	RV11	POSITION SHIFT Spindle stop position shift.		The spindle stop position can be finely adjusted within a range $\pm 1^\circ$ the spindle angle.
12	RV12 DC	HIGH GAIN DC High gain.	Adjust RV12 when DC spindle servo unit is used.	Standard adjusting value: 7 divisions.
13	RV12 AC	HIGH GAIN AC High gain.	Adjust RV12 when AC spindle servo unit is used.	Standard adjusting value: 7 divisions.

After adjustments, cancel the test mode, and make sure that the LED7 (red) goes out.

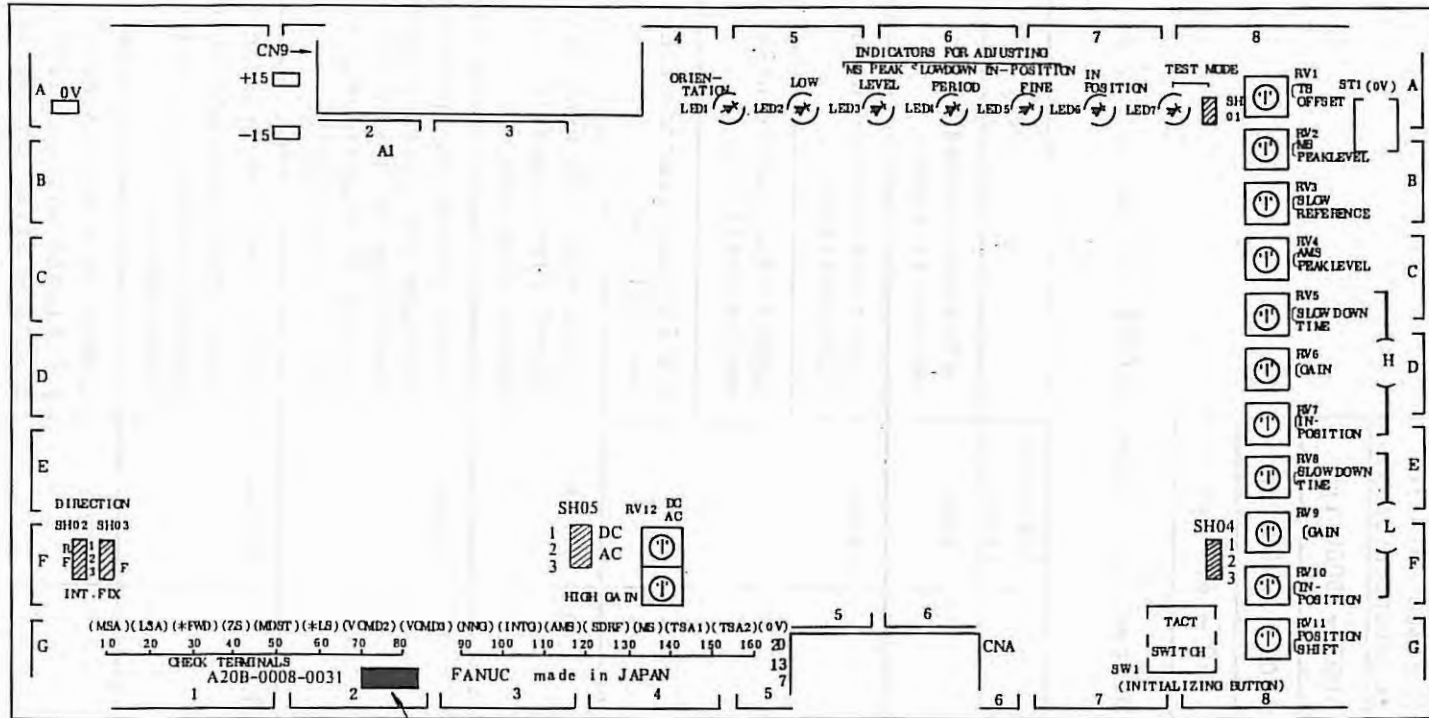

Overall version number indication

Fig. 7.3.3 Mounting positions of check terminals, variable resistors, setting pins and light-emitting diodes (LED) (PCB A20B-0008-0031)

7.3.4 Setting and adjustment of spindle orientation control circuit in case of 3-step spindle speed change

PCB A20B-0009-0520 is employed as spindle orientation control circuit D (A06B-6041-J121). This paragraph describes the setting and adjusting methods of this circuit.

Note) Be careful since the maximum spindle revolution range is limited at each speed change step.

	Maximum spindle revolution range
High speed	4000 - 8000 rpm
Medium speed	1000 - 2000 rpm
Low speed	250 - 677 rpm

- 1) Setting and functions of setting terminals (SH) same as in 7.3.2
- 2) LED display contents

LED No.	Symbols	Lighting color	Description
LED1	ORIENTATION	Green	Lights when orientation command is input.
LED2H	GEAR/CLUTCH	Green	Lights when gear/clutch is set to high positions.
LED2M			Lights when gear/clutch is set to medium position.
LED2L			Lights when gear/clutch is set to low position.
LED3	MS PEAK LEVEL	Green	Lights when the peak value of MS signal from magnetic sensor is higher than ± 10 V.
LED4	SLOWDOWN PERIOD	Green	Lights during the period from the constant low speed just before completion of orientation to the arrival of magnetizing sensor at the sensor position.
LED5	IN-POSITION FINE	Green	Lights when the spindle is positioned within $\pm 0.1^\circ$ of the stop position after completion of orientation.
LED6	IN-POSITION	Green	Lights when the spindle is positioned within $\pm 1.0^\circ$ of the stop position after completion of orientation. Orientation end signal is sent when this LED is lighting in a mode other than TEST mode.
LED7	TEST MODE	Red	Lights when setting terminal SH01 is shorted across 01 and 02.

3) Adjustments

Observe the following procedure in the test mode after turning on the power supply.

Item	Variable resistor	Adjustment item	Conditions	Adjusting method
1	RV1	TS OFFSET Tachogenerator offset. (Compensation for the difference of the slow down time in normal and reverse rotating direction)	Compare the slow down time during the orientation in normal and reverse directions after completion of this adjustments.	The standard setting value is 5 divisions. Adjust RV1 until the difference of the slow down time between normal and reverse rotation become shorter than 0.1 sec.
2	RV2	MS PEAK LEVEL MS signal amplitude value.	Keep depressing SW1	Set VR2 at the position where LED3 beging flickering.
3	RV3	SLOWDOWN REFERENCE (Slowdown speed reference.)	Check the distance from the spindle center to the sensor head.	Set RV3 and RV4 according to (Note 1).
4	RV4	AMS PEAK LEVEL (AMS signal amplitude value.)		
5	RV5	SLOWDOWN TIME (HIGH) (Slowdown time)	Repeat turning on and off SW1 while LED2H (clutch (gear) HIGH) is lighting.	LED4 should clearly light for a moment (about 0.2 sec) just before stopping.
6	RV6	GAIN (HIGH) (Position loop gain)		Turn RV6 clockwise to such an extent as does not cause any overshoot when the spindle stops.
7	RV7	IN-POSITION (H) (Spindle stop position adjustment)	Same as above	Adjust RV7 so that LED5 lights concurrently while LED6 is lighting. LED5 may flicker.
8	RV8	SLOWDOWN TIME (LOW) (Slowdown time)	Repeat turning on and off SW1, while LED2L (clutch (gear) LOW) is lighting.	Same as in item 5 in this table.
9	RV9	GAIN (LOW) (Position loop gain)		Same as in item 6 in this table.

Item	Variable resistor	Adjustment item	Conditions	Adjusting method
10	RV10	IN-POSITION (LOW) (Spindle stop position adjustment)	Repeat turning on and off SW1, while LED2L (clutch (gear LOW) is lighting.	Same as in item 7 in this table.
11	RV11	SLOWDOWN TIME (MEDIUM) (Slowdown time)	Repeat turning on and off SW1 while LED2M (clutch (gear MEDIUM) is lighting.	Same as in item 5 in this table.
12	RV13	GAIN (MEDIUM) (Position loop gain)		Same as in item 6 in this table.
13	RV14	IN-POSITION (MEDIUM) (Spindle stop position adjustment)		Same as in item 7 in this table.
14	RV11	POSITION SHIFT (Spindle stop position shift)	The spindle stop position can be finely adjusted down to $\pm 1^\circ$ at spindle angle.	Set the key position of ATC arm to the keyway position of spindle.
15	RV15DC	HIGH GAIN DC High gain	Adjustment using DC spindle servo unit.	Standard adjusting value: 0 division.
16	RV15AC	HIGH GAIN AC High gain	Adjustment using AC spindle servo unit.	Standard adjusting value: 7 divisions.

Reset the test mode after adjustments.

Note 1) Adjust RV3 and RV4 according to the distance (H) from the spindle center to the sensor as follows.

H (mm)	50	60	70	80	90	100	110	120
RV3, 4 scale	9.5	6.5	4.5	3.0	2.2	1.5	1.0	0.5

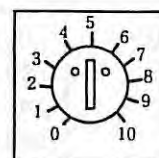

Variable resistor scale divisions

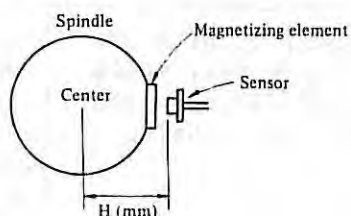

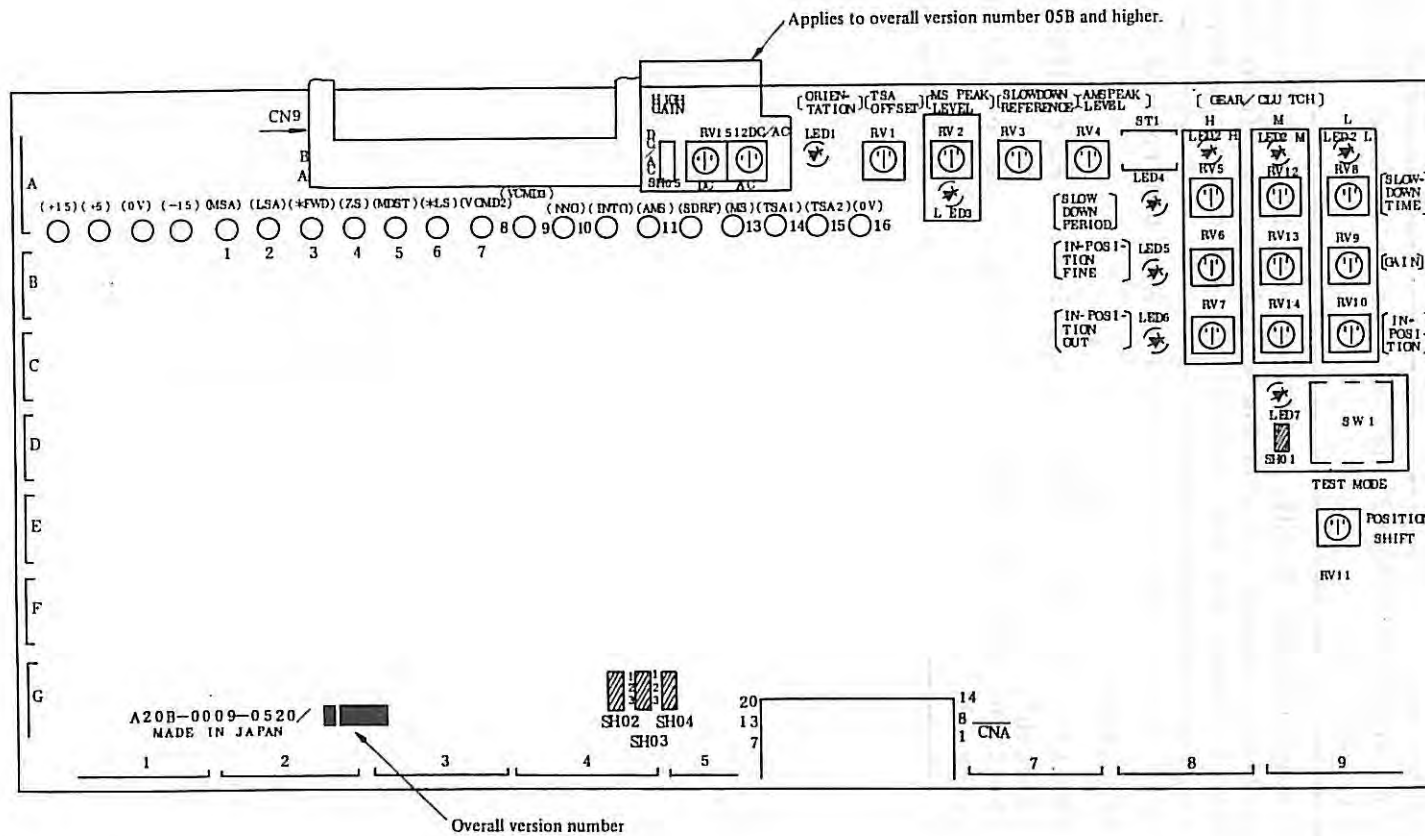

Fig. 7.3.4 Mounting positions of check terminals, variable resistors, setting pins, and light emitting diodes (LED)
(PCB A20B-0009-0520)

7.3.5 Method of checking the spindle position loop gain

The spindle position loop gain can be checked according to the following procedure. Check it after adjusting the spindle orientation control circuit.

Procedure of checking the spindle position loop gain

1	Set the mode to TEST mode (LED7 ON) after shorting setting terminal SH01 pins.
2	Release setting terminal SH04 1-2 and 2-3 pins to release the speed limitation of orientation.
3	Measure spindle revolutions $N_s(H)$, $N_s(L)$ rpm when SW1 (INITIALIZING button) is depressed (turned on) and the spindle clutch (gear) is set to HIGH (*CT *CTH1, 2: Open) and LOW (*CTH1, 2: Closed), respectively.
4	<p>The spindle position loop gain can be obtained by the following formula.</p> $K_P (H \text{ or } L) = N_s (H \text{ or } L) \div 55 (\text{sec}^{-1})$ <p>where $K_P (H)$: Position loop gain when the spindle is set to HIGH gear (clutch). $K_P (L)$: Position loop gain when the spindle is set to LOW gear (clutch).</p>

II. AC SPINDLE SERVO UNIT
(380/415V AC INPUT)

1. OUTLINE

This Section describes maintenance of the 380/415V AC input type spindle servo unit.

1.1 Configuration

The AC380/415V AC spindle servo unit consists of the unit, PC board, and ROM.

Model Name	Specification DWG No.	Unit DWG No.	PCB DWG No.	ROM	
				Specified DWG No.	Classification
Model 30	A06B-6054 -H030	A06B-6054 -C040	A20B-1001 -0620	A06B-6054 -C530	JUA
Model 40	A06B-6054 -H040	A06B-6054 -C040		A06B-6054 -C540	JUB

2. DAILY MAINTENANCE AND MAINTENANCE TOOL

See item 2 in Chapter I in this manual.

3. INSTALLATION











For power supply line, power line and signal line connections, refer to the "Connection Diagram" in Appendix 1. A single-phase AC220V power supply line connection is added to this unit. The fan for AC spindle motor cooling employs a 3-phase motor. For a signal line soft start/stop cancel SOCN is added thereto.



4. SETTING AND ADJUSTMENT

4.1 Setting on PCB

For the location on the PCB, refer to the "Parts Location" in Appendix 6. Before turning power ON, check the following setting.

Table 4.1 (a) Setting

Setting terminal number	Contents		Setting		Setting at shipment from factory
S1	Machine ready signal (MRDY)	Used	OFF	 ON	OFF
		Not used	ON	 ON	
S2	Analog override	Used	OFF	 ON	OFF
		Not used	ON	 ON	
S3	Same as the above	Used	ON	 ON	ON
		Not used	OFF	 ON	
S4	Velocity command signal	Use of external analog voltage command	OFF	 ON	OFF
		Use of R01 - R12 commands	ON	 ON	
S5A S5B	Setting of velocity feedback amount to rated command		S5A	S5B	
		2000 rpm	OFF	OFF	
		3500 rpm	ON	OFF	
		4500 rpm	OFF	ON	o
		Not used	ON	ON	
S8	Delay time required until motor is de-energized	0 sec/option	OFF	 ON	ON (Note 1)
		0.2 sec/standard	ON	 ON	

Setting terminal number	Contents		Setting	Setting at shipment from factory
S11	Soft start/stop time constant switching (Adjust by RV20)	0.6 8 sec	A  B A	A
		3.5 40 sec	B  B A	

Note 1) Insert a short bar without fail even when setting is turned off.

Variable resistors RV1 - RV19 of the spindle control circuit PCB have been adjusted at factory before shipment, and their adjustments are no longer necessary, in principle.

However, the set values of variable resistors shown in Table 4.1 (b) are changeable as required. Readjust variable resistors shown in Table 4.1 (c) after turning on the power supply, if fine adjustment is required for offset, rotating speed, etc.

1) Variable resistors whose set values are changeable.

Table 4.1 (b)

Variable resistor number	Use	Standard adjustment at shipment from factory	Setting change method
RV3	Set speed arrival level	Sends speed arrival signal when the motor speed reaches 85 - 115% of the command speed.	See appendix 8.
RV4	Speed detection level	3% of the maximum speed is detected.	See appendix 8.
RV5	Torque limit value		See appendix 8.
RV20	Soft start/stop time constant adjust		See appendix 8. (Note 1)

2) Variable resistors for fine adjustment of offset and rated speed.

Table 4.1 (c)

Variable resistor number	Use	Adjusting method
RV1	Adjusts the velocity command voltage level.	See appendix 8.
RV2	Adjusts the velocity command voltage offset.	See appendix 8.
RV9	Finely adjusts the rated speed in normal rotation (SFR).	See appendix 8. (Note 2)
R11	Finely adjusts the rated speed in reverse rotation (SRV).	See appendix 8. (Note 2)
R13	Adjusts the offset when zero speed is commanded.	See appendix 8.

Note 1) For details, refer to the "PCB Adjustment" in Appendix 8 in this manual.
Note 2) Adjust the number of revolution both in the forward direction (CCW) and the reverse direction (CW), using RV9.

5. TROUBLESHOOTING AND COUNTERMEASURE

See item 3 in Chapter I in this manual.

III. DIGITAL AC SPINDLE SERVO UNIT
(MODEL 3 ~ 22)

1. OUTLINE

This is the manual that describes maintenance of digital AC spindle servo unit (MODEL 3 - 22).

1.1 Configuration

Digital AC SPINDLE SERVO UNIT consists of unit part, printed circuit board, and ROM.

Table 1.1 Element of configuration

Name of AC spindle servo unit	Specification of spindle servo unit *Note	Specification of unit part *Note	Specification of printed circuit board	ROM	
				Specifications	Type
MODEL 3 6000rpm	A06B-6055-H103#H500 A06B-6055-H203#H500	A06B-6055-H103 A06B-6055-H203	A20B-1001 -0120	A06B-6055-H500	9600
MODEL 6 6000rpm	A06B-6055-H106#H501 A06B-6055-H206#H501	A06B-6055-H106 A06B-6055-H206		A06B-6055-H501	9601
MODEL 8 4500rpm	A06B-6055-H108#H502 A06B-6055-H208#H502	A06B-6055-H108 A06B-6055-H208		A06B-6055-H502	9602
MODEL 8 6000rpm	A06B-6055-H108#H503 A06B-6055-H208#H503			A06B-6055-H503	9603
MODEL 12 4500rpm	A06B-6055-H112#H504 A06B-6055-H212#H504	A06B-6055-H112 A06B-6055-H212		A06B-6055-H504	9604
MODEL 12 6000rpm	A06B-6055-H112#H505 A06B-6055-H212#H505			A06B-6055-H505	9605
MODEL 15 4500rpm	A06B-6055-H115#H506 A06B-6055-H215#H506	A06B-6055-H115 A06B-6055-H215		A06B-6055-H506	9606
MODEL 15 6000rpm	A06B-6055-H115#H507 A06B-6055-H215#H507			A06B-6055-H507	9607
MODEL 18 4500rpm	A06B-6055-H118#H508 A06B-6055-H218#H508	A06B-6055-H118 A06B-6055-H218		A06B-6055-H508	9608
MODEL 22 4500rpm	A06B-6055-H122#H510 A06B-6055-H222#H510	A06B-6055-H122 A06B-6055-H222		A06B-6055-H510	9610
High-speed MODEL 3 12000rpm	A06B-6055-H103#H512 A06B-6055-H203#H512	A06B-6055-H103 A06B-6055-H203		A06B-6055-H512	9612
High-speed MODEL 6 12000rpm	A06B-6055-H108#H513 A06B-6055-H208#H513	A06B-6055-H108 A06B-6055-H208		A06B-6055-H513	9613

Note) Upper: Internal ventilation type
Lower: External radiation type

2. DAIRY MAINTENANCE AND INSTRUMENTS FOR MAINTENANCE

See this maintenance manual, item 2 in Chapter I.

3. INSTALLATION

The same interface as for the conventional model is applied. See this maintenance manual, item 4 in Chapter I, for procedure of installation, wiring connection of power supply, and AC spindle motor connection.

Table 1.1. Dimensions of the instrument

Part No.	Part Name	Dimensions (mm)	Material
0000	Case	100 x 100 x 100	Aluminum
1001	Panel	100 x 100	Aluminum
2002	Terminal Block	50 x 20	Plastic
3003	Mounting Bracket	100 x 50	Steel
4004	Power Supply Unit	100 x 50 x 50	Aluminum
5005	Control Panel	100 x 100	Aluminum
6006	Indicator Light	20 x 20	Plastic
7007	Switch	20 x 20	Plastic
8008	Resistor	10 x 10	Carbon
9009	Capacitor	10 x 10	Aluminum
0010	Wiring Harness	100 x 100	Copper
1011	Terminal Block	50 x 20	Plastic
2012	Mounting Bracket	100 x 50	Steel
3013	Power Supply Unit	100 x 50 x 50	Aluminum
4014	Control Panel	100 x 100	Aluminum
5015	Indicator Light	20 x 20	Plastic
6016	Switch	20 x 20	Plastic
7017	Resistor	10 x 10	Carbon
8018	Capacitor	10 x 10	Aluminum
9019	Wiring Harness	100 x 100	Copper

4. SETTING

Setting is the same on the unit as for the conventional model. Setting and adjustment of the printed circuit board has been changed into parameter setting from setting by short pin and adjustment with volume, however. See the following instructions for setting.

- 4.1 Method of Parameter Setting
- 4.2 Number and Contents of Parameter
- 4.3 Rank at Setting

4.1 Method of Parameter Setting

Setting switch and display are configured on the printed circuit board as follows. Check and change of setting for each mode can be made by operating this switch as shown in the next page.

Display





Setting switch



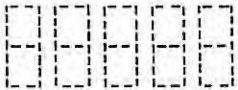

- 1) For checking present mode
 - a) Number of rotation is shown (in five digits) on the display normally.

Present mode number is indicated when "MODE" key is turned ON.

Mode number is indicated in two digits as "F-XX".
- 2) For checking setting data
 - a) Select the mode (parameter) of the data that needs be checked in the following procedure.
 - b) Keep pressing four buttons "MODE", "UP", "DOWN", "DATA SET" key simultaneously for more than one second.
 - c) Display is changed from blank  to .
 - d) Turn OFF all the switches.
 - e) Present mode is displayed when "MODE" key is ON.
 - f) One mode is increased when "UP" key is ON with "MODE" key ON.
 - g) More modes are continuously increased when "UP" key is kept ON with "MODE" key ON.
 - h) One mode is subtracted when "DOWN" key is ON with "MODE" key ON.

- i) More modes are continuously increased when "DOWN" key is kept ON with "MODE" key ON.
- j) Data is displayed (in four digits) 0.5 second later when "MODE" key is turned OFF.
- k) Rotation number display is made in about 10 seconds after data display is made.

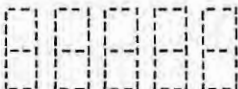
When all the switches are turned off, rotation number is displayed finally no matter what the mode may be.

- 3) For changing data
 - a) Refer to the procedure shown in (b) to (i) to select the mode (parameter) to be changed.
 - b) Data is displayed in about 0.5 second after "MODE" key is turned OFF.
 - c) One data is increased when "UP" key is ON.
 - d) More data is continuously increased when "UP" key is kept ON.
 - e) One data is subtracted when "DOWN" key is ON.
 - f) More data is continuously increased when "DOWN" key is kept ON.
 - g) Motor is controlled by the data displayed.
 - h) Keep "DATA SET" key ON for more than a second to replace by the data after change.
 - i) Display is changed from blank  to  for completion of change.
 - j) Follow the procedure from a) for another data change.
 - k) Rotation number display is made in about 10 seconds after all the switches are turned OFF. As for F-13, F-14, and F-30, rotation number display is made about two seconds later, however.

4.2 Number and Contents of Parameter

1) Display of motor revolution number

Mode number	Display data (five digits)	Contents of data
F-00	<input type="text"/>	Displays motor revolution number (rpm)

2) Machine ready signal (MRDY): Use/Non-use

Mode number	Display data (four digits)	Contents of data
F-01	0001	0, 1 (Standard setting: 1)

Data

Explanation: When machine ready signal (MRDY) is used 1
 When machine ready signal (MRDY) is not used 0

3) Use/Non-use of override function

Mode number	Display data (four digits)	Contents of data
F-02	0001	0, 1 (Standard setting: 1)

	Data
Explanation: When override function is used	1
When override function is not used	0

4) Override range setting

Mode number	Display data (four digits)	Contents of data
F-03	0001	0, 1 (Standard setting: 1)

	Data
Explanation: Upper limit of override range = - 120% --	1
Upper limit of override range = - 100% --	0

Caution: When velocity override is not used for the mode F02 setting data = 0, set "0" into the setting data.

5) Setting of kind of velocity command (External analog voltage, DA converter)

Mode number	Display data (four digits)	Contents of data
F-04	0001	0, 1 (Standard setting: 0)

	Data
Explanation: When external analog voltage is used	0
When DA converter is used	1

6) Setting of maximum revolution number

Mode number	Display data (four digits)	Contents of data
F-05		0 - 3 (setting is performed with motor specifications.)

Explanation:	Standard specification	High-speed specification	Setting data
	- 5000 rpm	- 10000 rpm	0
	- 6000 rpm	- 12000 rpm	1
		- 15000 rpm	2
		- 20000 rpm	3

7) Output limit pattern setting

Mode number	Display data (four digits)	Contents of data
F-06	0000	0 - 3 (Standard setting: 0)

Explanation: No other conventional type units are equipped with this function. Select a proper pattern specified as follows.

- A. Output limiting is made only at acceleration and deceleration. Acceleration/deceleration is slowly made and operation is made with rated output at normal rotation. (Setting data: 1) (A similar function to soft start/stop)
- B. Acceleration/deceleration is made with maximum rated output, and output limiting is made at normal rotation. (Setting data: 2)
- C. Alteration of output specification is made for the machine with motor and amplifier of the identical specifications. (Setting data: 3)

Contents	Setting data
Output limiting is not made.	0
Output limiting is made only at acceleration/deceleration.	1
Output limiting is made at normal rotation, not at acceleration/deceleration.	2
Output is limited for all operations.	3

Output limit pattern 1 Setting data = 1, 2, 3

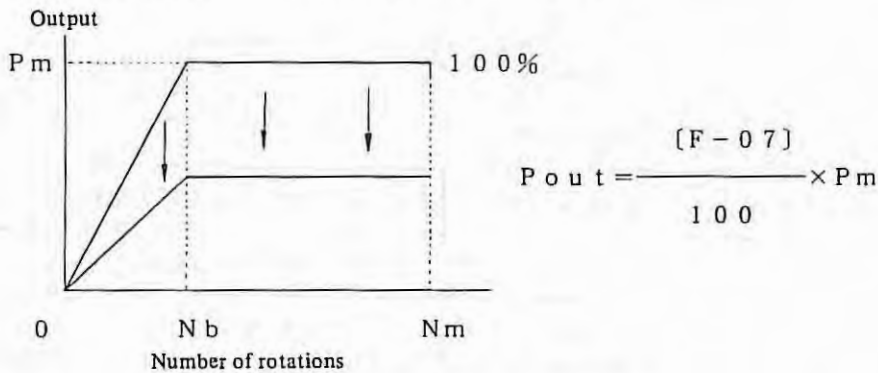

Output limit pattern 2 Setting data = 4, 5, 6

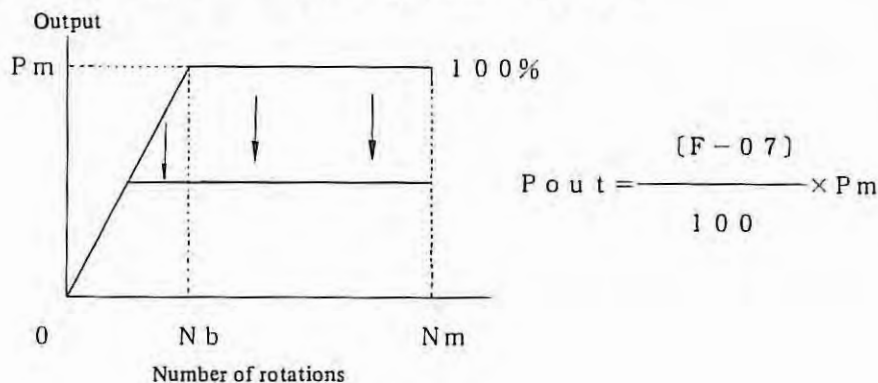

8) Setting of limit value at output limit

Mode number	Display data (four digits)	Contents of data
F-07	0100	0 - 100(Standard setting: 100)

Explanation: Set the value to be limited at 100% of maximum rated output (overload tolerance).
It is effective at output limit set on the mode F-06.

$$\text{Output limit value} = \text{Maximum rated output} \times (\text{Setting data}) \%$$

9) Delay time before cutting motor power supply

Mode number	Display data (four digits)	Contents of data
F-08	0005	0 - 255 (Standard setting: 5)

Explanation: Delay time from zero speed signal detection to motor power supply disconnection is set.

$$\text{Delay time} = (\text{Setting data}) \times 40 \text{ msec.}$$

10) Use/Non-use of motor power supply shutting off by machine ready signal (MRDY)

Mode number	Display data (four digits)	Contents of data
F-09	0000	0, 1 (Standard setting: 0)

Explanation: It is used when frequent switching of electro-magnetic contactor is expected. Only motor power supply is shut off while electro-magnetic contactor stays ON, when machine ready signal (MRDY) is turned OFF.

	Data
When this function is used	1
When this function is not used	0

11) Velocity deviation offset adjustment at forward rotation command (SFR)

Mode number	Display data (four digits)	Contents of data
F-10	0128	0 - 255(Standard setting: 128)

Explanation: This adjustment is made in order to stop motor at the time forward rotation command (SFR) and velocity command voltage, 0V (zero rotation command) are given. Add more data (UP) to stop the motor turning counterclockwise (CCW) relatively to its shaft.

12) Velocity deviation offset adjustment at reverse rotation command (SRV)

Mode number	Display data (four digits)	Contents of data
F-11	0128	0 - 255(Standard setting: 128)

Explanation: This adjustment is made in order to stop the motor at the time reverse rotation command (SRV) and velocity command voltage, 0V (zero rotation command) are given. Add more data (UP) to stop the motor turning counterclockwise (CCW) relatively to its shaft.

13) Speed deviation offset adjustment at orientation command (ORCM)

Mode number	Display data (four digits)	Contents of data
F-12	0128	0 - 255 (Standard setting: 28)

Explanation: Use this parameter for adjustment in case LED 06 IN-POSITION FINE can not be illuminated by adjustment volume on the orientation circuit at orientation.

14) Rotation number adjustment at forward rotation command (SFR)

Mode number	Display data (four digits)	Contents of data
F-13		0 - 255 (Setting is based on motor specification.)

Explanation: Rotation number is adjusted as specified by the command when velocity command is input at forward rotation command (SFR). Increase more data (up) to increase rotation number.

15) Rotation number adjustment at reverse rotation command (SRV)

Mode number	Display data (four digits)	Contents of data
F-14		0 - 255 (Setting is based on motor specification.)

Explanation: Rotation number is adjusted as specified by the command when velocity command is input at reverse rotation command (SRV). Increase more data (up) to increase rotation number.

16) Setting of rotation number at velocity command voltage, 10 V

Mode number	Display data (four digits)	Contents of data
F-15		0 - Rated rotation number (Setting is based on motor specification.)

Explanation: Make sure to have this setting when rotation adjustment of (14) and (15). Set the value which rotation number at velocity command voltage, 10 V is divided by 100.

Rotation number (rpm) at velocity command voltage, 10V=(Setting data)x100

17) Detection range of velocity arrival signal (SAR)

Mode number	Display data (four digits)	Contents of data
F-16	0015	0 - 100 (Standard setting: 15)

Explanation: Setting of detection range of velocity arrival signal is made. Speed arrival signal (SAR) is fed (ON) when motor revolution number reaches to $\pm(\text{set data})\%$ of command rotation number.

Detection range = Command rotation number x within $\pm(\text{Set data})\%$

18) Detection range of speed detection signal (SDT)

Mode number	Display data (four digits)	Contents of data
F-17	0003	0 - 100 (Standard setting: 3)

Explanation: Setting of detection range of speed detection signal (SDT) is made. Speed detection signal (SDT) is fed (ON) when motor revolution number becomes less than the $(\text{set data})\%$ of maximum number of revolution.

Detection range = Maximum number of revolution x less than the $(\text{Set data})\%$

19) Setting of torque limit value

Mode number	Display data (four digits)	Contents of data
F-18	0050	0 - 100 (Standard setting: 50)

Explanation: Setting of torque limit value at torque limit signal (TLMH) ON is made.

Torque limit value = Maximum rated torque x $(\text{Set data})\%$

20) Setting of acceleration/deceleration time

Mode number	Display data (four digits)	Contents of data
F-19	0010	0 - 255 (Standard setting: 10)

Explanation: This setting is made when acceleration time from stop to maximum rotation number is more than five seconds.

Set value = Acceleration time (Second) x 2

21) Limiting of regenerated power (adjustment of deceleration time)

Mode number	Display data (four digits)	Contents of data
F-20	0060	0 - 100 (Standard setting: 60)

Explanation: Adjust the deceleration time so that it is the same as acceleration time. Deceleration time is shortened when setting value is large. Deceleration time gets longer when it is small. Motor may make abnormal sounds if regenerated power is excessively large, as the regeneration limit circuit functions to change the waveform of the motor current. Make the setting smaller in such a case.

22) Setting of velocity control phase compensation P: HIGH gear (CTH = 1)

Mode number	Display data (four digits)	Contents of data
F-21	0050	0 - 255 (Standard setting: 50)

23) Setting of velocity control phase compensation P: LOW gear (CTH = 0)

Mode number	Display data (four digits)	Contents of data
F-22	0050	0 - 255 (Standard setting: 50)

24) Setting of velocity control phase compensation P at orientation: HIGH gear (CTH = 1)

Mode number	Display data (four digits)	Contents of data
F-23	0100	0 - 255 (Standard setting: 100)

25) Setting of velocity control phase compensation P at orientation: LOW gear (CTH = 0)

Mode number	Display data (four digits)	Contents of data
F-24	0100	0 - 255 (Standard setting: 100)

26) Setting of velocity control phase compensation I: HIGH gear (CTH = 1)

Mode number	Display data (four digits)	Contents of data
F-25	0030	0 - 255 (Standard setting: 30)

27) Setting of velocity control phase compensation I: LOW gear (CTH = 0)

Mode number	Display data (four digits)	Contents of data
F-26	0030	0 - 255 (Standard setting: 30)

28) Setting of velocity control phase compensation I at orientation: HIGH gear (CTH = 1)

Mode number	Display data (four digits)	Contents of data
F-27	0030	0 - 255 (Standard setting: 30)

29) Setting of velocity control phase compensation I at orientation: LOW gear (CTH = 0)

Mode number	Display data (four digits)	Contents of data
F-28	0030	0 - 255 (Standard setting: 30)

30) Velocity detection offset

Mode number	Display data (four digits)	Contents of data
F-29	0128	0 - 255 (Adjustment at Shipping: about 128)

Explanation: Adjust it so that check terminal "TS3" is 0 mV, with the motor stopped.

31) Adjustment of revolution number display

Mode number	Display data (four digits)	Contents of data
F-30	3990	0 - 8191 (Adjustment at Shipping: about 3990)

Explanation: It is setting for adjustment of display of motor revolution number. Make the setting smaller when more number is displayed than actual number of motor revolution.

32) Setting of rigid tap mode

Mode number	Display data (four digits)	Contents of data
F-31	0000	0 - 1 (Standard setting: 0)

Explanation: Torque limit signal (TLML) is used the same as for conventional type torque limit. 0

Torque limit signal (TLML) is used for improvement of response characteristics such as digit tapping function as a switch for motor voltage. 1

33) Setting of motor voltage at normal operation

Mode number	Display data (four digits)	Contents of data
F-32	0010	0 - 100 (Standard setting: 10)

34) Setting of motor voltage at orientation

Mode number	Display data (four digits)	Contents of data
F-33	0010	0 - 100(Standard setting: 10)

35) Setting of motor voltage at rigid tap mode

Mode number	Display data (four digits)	Contents of data
F-34	0100	0 - 100(Standard setting: 100)

Explanation: This setting is effective when the set data of mode F-31 is "1".

36) Setting of speed zero signal (SST) detection level

Mode number	Display data (four digits)	Contents of data
F-35	0075	0 - 255(Standard setting: 75)

Explanation: It is setting for speed zero signal (SST) detection level. Speed zero signal is output when the number of revolution of motor becomes less than the (Set data/100)% of maximum number of revolution.

Detection level = {max. number of revolution x (setting data/100)%}

4.3 Rank at Setting

Parameter is already set at shipping for the application similar to the conventional kind. And therefore, the setting of A in the rank below usually needs to be confirmed or altered by machine manufacturers.

Please have your own ranking at change of application conditions (change of rotation number and special setting).

Please be sure not to change setting values.

Setting of rank A (necessary to be confirmed without fail)

Rank	Mode number	Contents
A	F-01	Setting of use/non-use of machine ready signal
	F-02	Setting of use/non-use of override function
	F-03	Setting of override range
	F-04	Setting of kind of velocity commands (analog voltage, DA converter)

Setting of rank B (when rotation number is changed)

Rank	Mode number	Contents
B	F-13	Rotation number adjustment of forward rotation
	F-14	Rotation number adjustment of reverse rotation
	F-15	Rotation number at maximum velocity command voltage (10 V)

Setting of rank C (when special setting is made)

Rank	Mode number	Contents
C	F-16	Detection range of velocity arrival signal
	F-17	Detection level of velocity detection signal
	F-18	Setting of Torque limit value
	F-19	Setting of acceleration/deceleration time
	F-20	Limiting of regenerated power (adjustment of deceleration time)
	F-09	Use/non-use of motor power supply shutting off by machine ready signal
	F-35	Speed zero signal detection level

5. TROUBLESHOOTING AND COUNTERMEASURE

See item 3 in Chapter I for troubleshooting and countermeasure depending on the condition of trouble when there is a trouble.

Note that the following items have been changed.

- 1) Name of the display lamp for power ON is changed as LED1 from PIL.
- 2) Fuse (AF2, AF3) have been changed as fuse resistor (FR1, FR2).
- 3) Alarm display of four LEDs have been replaced by Direct display (AL-OO) with five digits and seven segments.
- 4) Alarm contents are as follows.

Alarm contents

Alarm display	Alarm contents	Alarm output code
AL-01	Motor is overheated. (Thermostat operates)	No. 1
AL-02	Velocity deviation is excessive against command velocity because of overload, etc.	No. 2
AL-03	Fuse F7 at DC link is blown.	No. 3
AL-04	Fuse F1, F2, or F3 at AC input is blown.	No. 4
AL-06	Velocity of motor is exceeded to the maximum rated speed. (Analog system detection)	No. 6
AL-07	Velocity of motor is exceeded to the maximum rated speed. (Digital system detection)	No. 7
AL-08	Power supply voltage is too high.	No. 8
AL-09	Heat sink for power semiconductor is overheated.	No. 9
AL-10	Voltage of +15 V power supply is abnormally low.	No. 10
AL-11	Voltage at DC link is abnormally high.	No. 11
AL-12	Current at DC link is too much.	No. 12
AL-13	Data memories of the CPU are in abnormal condition.	No. 13
AL-16	RAM in NVRAM is in abnormal condition.	
AL-17	ROM in NVRAM is in abnormal condition.	
AL-18	Sum check alarm of ROM.	
AL-19	Excessive alarm of U phase current detection circuit offset.	
AL-20	Excessive alarm of V phase current detection circuit offset.	
AL-21	Excessive alarm of velocity command circuit offset.	

Outline of spindle servomotor drawing on page 156

Alarm display	Alarm contents	Alarm output code
AL-22	Excessive alarm of velocity detection circuit offset.	No. 13
AL-23	Excessive alarm of ER circuit offset.	
AL-14	ROM is in abnormal condition.	
AL-15	Spindle selection control circuit is in abnormal condition.	

6. METHOD OF REPLACEMENT OF FUSE AND PRINTED CIRCUIT BOARD

Replace the two ROMs and NVRAM for parameter to new PCB, when change the PCB. After changing the PCB, perform the adjustment of F29 (speed offset) and set the adjustment data.

See item 6 in Chapter I for other contents.

7. SPINDLE ORIENTATION CONTROL CIRCUIT

See item 7 in Chapter I for maintenance and adjustment of spindle orientation control circuit.

See appendix for information of other maintenance.

IV. DIGITAL AC SPINDLE SERVO UNIT
(MODEL 1S, 1.5S, 2S, 3S, 2H, 2VH)

1. OUTLINE

This material describes the maintenance of digital AC spindle servo unit model 1S, 1.5S, 2S, 3S, 2H, and 2VH.

1.1 Configuration

A digital AC spindle servo unit is composed of unit part, PCB part, and ROM.

Name	Specification	Unit specification	PCB specification	ROM	
				Drawing number	Type
Model 1 8000 RPM	A06B-6059-H001#H501	A06B-6059-H001	A16B-1100 -0200 + A16B-1100 -0240	A06B-6059-H501	9801
Model 1.5S 8000 RPM	A06B-6059-H002#H508	A06B-6059-H002		A06B-6059-H508	9808
Model 2S 8000 RPM	A06B-6059-H002#H502	A06B-6059-H002		A06B-6059-H502	9802
Model 3S 6000 RPM	A06B-6059-H003#H503	A06B-6059-H003		A06B-6059-H503	9803
Model 2H 15000 RPM	A06B-6059-H002#H505	A06B-6059-H002		A06B-6059-H505	9805
Model 2VH 20000 RPM	A06B-6059-H003#H507	A06B-6059-H003		A06B-6059-H507	9807

2. DAILY MAINTENANCE AND MAINTENANCE TOOL

Refer to item 2 in Chapter I in this manual.

3. INSTALLATION

The interface is the same as before. Relating to the installing procedures, power supply line connection and AC spindle motor connection, refer to the item 4 in Chapter I in this manual.

4. SETTING

The setting on the unit is the same as conventional digital AC SPINDLE SERVO UNIT (MODEL 3 - 22).

- 4.1 Parameter Setting Method
- 4.2 Number and Content of Parameter
- 4.3 Setting Rank
- 4.4 Setting Method of Short Pin
- 4.5 Adjustment Method of Variable Resistor

4.1 Parameter Setting Method

The setting switch and the display part are arranged on the PCB like the figure below.

As shown on the following pages, the setting in the respective modes can be checked and changed by manipulating this switch.

Display part



Setting switch



- 1) To confirm the current mode
 - a) The speed is usually displayed at the display part (Five digits). The current mode number can be displayed when "MODE" is turned on. The mode number is displayed as two digits of "F-XX".
- 2) To confirm the setting data
 - a) Select the mode of data to be checked (parameter) in the following manner.
 - b) Continuously turn 4 switches "MODE", "↑ UP", "↓ DOWN" and "DATA SET" ON at the same time for more than one second.
 - c) The display part changes from the blank to "FFFFFF".
 - d) Turned off all switches.
 - e) The current mode is displayed when "MODE" is turned on.
 - f) When "↑ UP" is turned ON with "MODE" ON, the mode is incremented by 1 (F01 - F02).
 - g) When "↑ UP" is continuously ON with "MODE" ON, the mode increases continuously (F35 - F34).
 - h) When "↓ DOWN" is turned ON with "MODE" ON, the mode is decremented by 1.
 - i) When "↓ DOWN" is continuously ON with "MODE" ON, the mode decrements continuously.
 - j) With "MODE" OFF, the data is displayed (4 digits) in approx. 0.5 second.
 - k) Approx. 10 seconds after the data display is selected, the speed rpm display is selected. When all switches are turned OFF in any mode, the speed rpm is finally displayed.

- 3) To alter the data
- Select the mode (parameter) to be changed according to the steps 2)-b) to 2)-i).
 - Turn "MODE" OFF: The data is displayed in approx. 0.5 second.
 - Turn "↑ UP" ON: The data is incremented by 1.
 - Turn "↑ UP" ON continuously: The data is incremented continuously.
 - Turn "↓ DOWN" ON: The data is decremented by 1.
 - Turn "↓ DOWN" ON continuously: The data is decremented continuously.
 - The motor is controlled by using the displayed data.
 - When replacing the data with the modified data, keep turning "DATA SET" ON for one second or more.
 - The display part changes from the blank to "88888" and modification of the data completes.
 - When changing the data once again, follow the steps from 3)-a) above.
 - The speed is indicated automatically after about 10 sec.

4.2 Number and Content of Parameter

1) Motor speed indication

Mode number	Display data (Five digits)	Contents of data
F-00		The speed of the motor is displayed. (rpm)

2) Use/no use of the machine ready signal (MRDY)

Mode number	Display data (Five digits)	Contents of data
F-01	0001	0, 1 (Standard setting: 0)

Explanation: If the machine ready signal (MRDY) is used : 1
 If the machine ready signal (MRDY) is not used: 0

3) Output limit pattern setting

Mode number	Display data (Four digits)	Contents of data
F-06	0000	0 to 6 (Standard setting: 0)

Explanation: This function is not available for a conventional type.
 In the following cases, please select a pattern which is appropriate respectively.

- When the output is limited only at acceleration and deceleration, the motor accelerates and decelerates slowly, and operates at the rated output during steady rotation (Setting data: 1 or 4) (function similar to soft start and stop)
- When the motor accelerates and decelerates at the maximum rated output and the output is limited during steady rotation (Setting data: 2 or 5)

C. When the same motor and amplifier are used to operate the machine as a different output specification machine (Setting data: 3 or 6)

Item	Content	Setting data	
		Pattern 1	Patter 2
	The output is not limited.	0	0
A	Output is limited only at acceleration and deceleration.	1	4
B	No output is limited at acceleration and deceleration but it is limited during steady rotation.	2	5
C	The output is limited over all movements.	3	6

(Output limit pattern 1): The setting data = 1, 2, 3

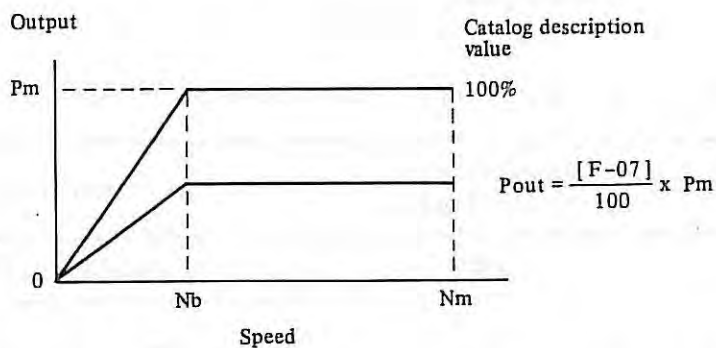

(Output limit pattern 2): The setting data = 4, 5, 6

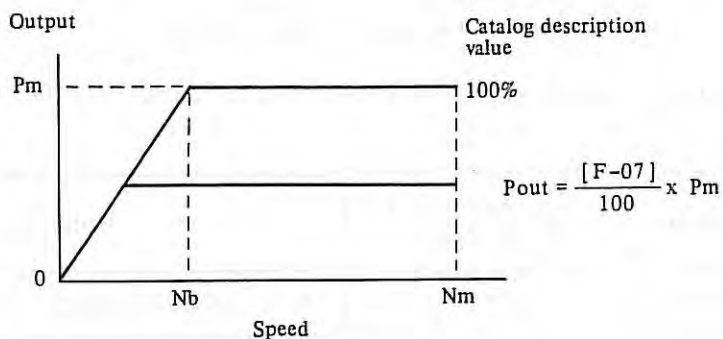

4) Limit value setting when the output is limited

Mode number	Display data (Four digits)	Contents of data
F-07	0100	0 to 100 (Standard setting: 100)

Explanation: With the maximum rated output (overload capacity) as 100%, set the limit value to a value to be limited. This preset value is available when the output is limited according to mode F-06 setting.

Output limit value = Maximum rated output x (setting data) %

5) Delay time to motor power interception

Mode number	Display data (Four digits)	Contents of data
F-08	0005	0 to 255 (Standard setting: 5)

Explanation: The delay time from 0 speed signal detection to the motor power interception is set.

Delay time = (Setting data) x 40 msec

6) Use/no use of the motor power interception by the machine ready signal (MRDY)

Mode number	Display data (Four digits)	Contents of data
F-09	0000	0, 1 (Standard setting: 0)

Explanation: The function is used when it is presumed that the electromagnetic contactor is switched frequently. When the machine ready signal (MRDY) is turned OFF, only motor power is interrupted, and the electromagnetic contactor remains ON.

If this function is used : 1

If this function is not used: 0

7) Adjustment of speed error offset at the time of the forward rotation command (SFR)

Mode number	Display data (Four digits)	Contents of data
F-10	0128	0 - 255 (Standard setting: 128)

Explanation: The speed error offset is adjusted when stopping motor operation with the forward rotation command (SFR) and speed command voltage 0 V (zero rotation command) applied. Increase the data when stopping the motor rotating counterclockwise (CCW), as viewed from the shaft.

- 8) Adjustment of speed error offset at the time of the reverse rotation command (SRV)

Mode number	Display data (Four digits)	Contents of data
F-11	0128	0 - 255 (Standard setting: 128)

Explanation: The speed error offset is adjusted when stopping motor operation with the reverse rotation command (SRV) and speed command voltage 0 V (zero rotation command) applied. Increase the data when stopping the motor rotating CCW, as viewed from the shaft.

- 9) Adjustment of speed error offset at the time of the orientation command (ORCM)

Mode number	Display data (Four digits)	Contents of data
F-12	0128	0 - 255 (Standard setting: 128)

Explanation: The parameter is used for adjustment when no adjustment is possible so that the LED of IN-POSITION FINE lights up at orientation, using the adjusting volume control on the orientation circuit.

- 10) F13 and F14 are not used. Please refer to item 4.5 for speed adjustment.

- 11) Speed adjustment when velocity command voltage is 10 V

Mode number	Display data (Four digits)	Contents of data
F-15		0 - Rated speed (It is decided by motor specification)

Explanation: When making velocity adjustments in para. 14) and 15) below, be sure to complete this setting. Set the value of Speed rpm at 10 V velocity command voltage/100.
 Speed rpm at 10 V velocity command voltage =
 (Setting data) x 100

- 12) Detection range of speed arrival signal (SAR)

Mode number	Display data (Four digits)	Contents of data
F-16	0015	0 - 100 (Standard setting: 15)

Explanation: The detection range of the speed arrival signal (SAR) is set. The speed arrival signal (SAR) is outputted when the motor speed reaches within \pm (Setting data) % of the command speed.
 Detection range = Command speed x \pm (Setting data) %

13) Detection range of speed detecting signal (SDT)

Mode number	Display data (Four digits)	Contents of data
F-17	0003	0 - 100 (Standard setting: 3)

Explanation: The detection range of the speed detecting signal (SDT) is set. The speed detecting signal (SDT) is outputted when the motor speed becomes (Setting data) % of a maximum speed or less.
 Detection range = Maximum speed x (Setting data) %

14) Setting of torque limit value

Mode number	Display data (Four digits)	Contents of data
F-18	0050	0 - 100 (Standard setting: 50)

Explanation: Torque limit value when the torque limit signal (TLMH) is turned ON is set.
 Torque limit value = Maximum ratings torque x (Setting data) %

15) Setting of acceleration/deceleration time

Mode number	Display data (Four digits)	Contents of data
F-19	0010	0 - 255 (Standard setting: 10)

Explanation: Set this time when the acceleration time between the stop and the maximum speed rpm is longer than 5 seconds.
 Preset time = Acceleration time (sec) x 2

16) Limit of regenerative power (Adjustment of deceleration time)

Mode number	Display data (Four digits)	Contents of data
F-20	0060	0 - 100 (Standard setting: 60)

Explanation: The deceleration time is adjusted to become the same as the acceleration time.
 The deceleration time shortens when the setting is enlarged.
 The deceleration time lengthens when the setting is reduced.
 However, when the regenerative power is excessive, the regenerative limit circuit is actuated and the motor current waveform changes; therefore, abnormal noise may be produced from the motor. In this case, this abnormal noise is suppressed by reducing the setting.

17) Setting of velocity control phase compensation P:HIGH gear (CTH = 1)

Mode number	Display data (Four digits)	Contents of data
F-21	0020	0 - 255 (Standard setting: 20)

18) Setting of velocity control phase compensation P:LOW gear (CTH = 0)

Mode number	Display data (Four digits)	Contents of data
F-22	0020	0 - 255 (Standard setting: 20)

19) Setting of velocity control phase compensation P in orientation time: HIGH gear (CTH = 1)

Mode number	Display data (Four digits)	Contents of data
F-23	0040	0 - 255 (Standard setting: 40)

20) Setting of velocity control phase compensation P in orientation time: LOW gear (CTH = 0)

Mode number	Display data (Four digits)	Contents of data
F-24	0040	0 - 255 (Standard setting: 40)

21) Setting of velocity control phase compensation I:HIGH gear (CTH = 1)

Mode number	Display data (Four digits)	Contents of data
F-25	0010	0 - 255 (Standard setting: 10)

22) Setting of velocity control phase compensation I:LOW gear (CTH = 0)

Mode number	Display data (Four digits)	Contents of data
F-26	0010	0 - 255 (Standard setting: 10)

23) Setting of velocity control phase compensation I in orientation time: HIGH gear (CTH = 1)

Mode number	Display data (Four digits)	Contents of data
F-27	0010	0 - 255 (Standard setting: 10)

- 24) Setting of velocity control phase compensation I in orientation time: LOW gear (CTH = 0)

Mode number	Display data (Four digits)	Contents of data
F-28	0010	0 - 255 (Standard setting: 10)

- 25) F-29 is not used. Please refer to item 4.5 for the speed detection offset adjustment.

- 26) F-30 is not used.

- 27) Setting of rigid tap mode

Mode number	Display data (Four digits)	Contents of data
F-31	0000	0 - 1 (Standard setting: 0)

Explanation: The torque limit signal (TLML) is used to a conventional torque limit: 0

The torque limit signal (TLML) is used for motor voltage switching when improved transient response characteristics are required for rigid tapping operation, for example: 1

- 28) Setting of motor voltage when usually operated

Mode number	Display data (Four digits)	Contents of data
F-32	0010	0 - 100 (Standard setting: 10)

- 29) Setting of motor voltage in orientation time

Mode number	Display data (Four digits)	Contents of data
F-33	0010	0 - 100 (Standard setting: 10)

- 30) Setting of motor voltage in rigid tap mode

Mode number	Display data (Four digits)	Contents of data
F-34	0100	0 - 100 (Standard setting: 100)

Explanation: This preset value is effective when mode F-31 setting data is 1.

31) Detection range of 0 speed signals (SST)

Mode number	Display data (Four digits)	Contents of data
F-35	0075	0 - 255 (Standard setting: 75)

Explanation: The detection range of 0 speed signals (SST) is set.
 0 speed signal (SST) is outputted when the speed of the motor becomes (The setting data/100)% of a maximum speed or less.
 The detection range = maximum speed x (The setting data/100)%

32) Detection range of load detection signal (LDT)

Mode number	Display data (Four digits)	Contents of data
F-36	0090	0 - 100 (Standard setting: 90)

Explanation: This function transmits a load detection signal when the motor output exceeds the preset value % of the maximum output (120% of 30-minute rating).

4.3 Setting Rank

For the usual applications, the parameter is factory preset before shipment; therefore, the machine tool builder should normally check or modify only the rank A setting.

When changing the operating conditions (change of speed rpm and special setting), the machine tool builder should divide the rank for use.

Please pay attention not to alter the setting value by mistake.

Setting of rank A (It must be confirmed without fail)

Rank	Mode number	Content
A	F-01	Setting of the use/no use of the machine ready signal

Setting of rank B (special setting)

Rank	Mode number	Content
B	F-16	Detection range of speed arrival signal
	F-17	Detection level of speed detecting signal
	F-35	Detection level of 0 speed signal
	F-18	Setting of torque limit value
	F-06, 07	Setting of output limit
	F-19	Setting of acceleration and deceleration time

Rank	Mode number	Content ^S
	F-20	Limit of regenerative power (Adjustment of deceleration time)
	F-09	Setting of the use/no use of the interception of the motor power by the machine ready signal
	F-36	Setting of load detection level

4.4 Setting Method of Short Pin

Name	Contents	Setting pin status			Setting before shipment
S1	Control circuit mode changeover	Test mode		TEST	DRIVE
		Normal operation mode		DRIVE	
S2 S3	The setting is as shown on the right, depending on the speed rpm during the rating command (VCMD = 10 V) - Detector I. Gear 256 teeth - Detector II. Gear 128 teeth	Detector I	Detector II		Setting according to each model
		6000RPM	D		
450RPM		8000RPM	C		
6000RPM		10000RPM 12000RPM	B		
		8000RPM 10000RPM	15000RPM 20000RPM	A	
S4 S5	Setting for gain switching	Normal operation mode		OFF	OFF
		For gain switching		ON	

4.5 Adjustment Method of Variable Resistor

Name	Contents		Adjustment before shipment	
RV1	Maximum speed adjustment in CWW direction		Adjustment for each model	
RV2	Maximum speed adjustment in CW direction			
RV3	Offset adjustment of velocity detecting circuit		Adjustment to 0 mV <u>+1</u> mV, using TS3 with rotation command OFF.	
RV4	+5 V voltage adjustment		Adjustment to +5 V <u>+0.1</u> V.	
RV5	Gain adjustment when the gain is switched		50%	
RV6	Gain adjustment of velocity detecting circuit for low speeds Apply VCMD (velocity command voltage) 25 mV <u>+2</u> mV to adjust the speed rpm for each model	Model	Adjusted value	Maximum speed
		1.5S, 3S, 6S	15 <u>+3</u> rpm	6000 rpm
		1S, 2S, 3	20 <u>+4</u> rpm	8000 rpm
		2H	37.5 <u>+8</u> rpm	15000 rpm
		2VH	50 <u>+10</u> rpm	20000 rpm

5. TROUBLESHOOTING AND COUNTERMEASURE

When faults take place, refer to item 3 in Chapter I in this manual according to trouble conditions, and locate the cause and take proper corrective measures. At that time, it should be noted that the following items are modified.

- 1) Change from alarm display using 4 LED's to Alarm No. direct display (AL-XX) using 5-digit segments.
- 2) To reset the alarm, turn "MODE" and "DATA SET" ON at the same time.
- 3) The alarm contents are as shown in the table below.

Content of alarm

Alarm display	Content of alarm
AL-01	The motor or servo unit becomes overheating. (Thermostat action)
AL-02	The speed deviates substantially from the speed command due to overload, for example, producing excessive speed error.
AL-03	The electric discharge circuit part is abnormal.
AL-04 to 05	----- (not used)
AL-06	The speed of the motor exceeds maximum ratings. (Analog method detection)
AL-07	The speed of the motor exceeds maximum ratings. (Digital method detection)
AL-08	The power supply voltage is too high.
AL-09	----- (not used)
AL-10	The voltage of power supply (+15 V) abnormally decreases.
AL-11	The voltage of DC link part is rising abnormally.
AL-12	The current of DC link part flows excessively.
AL-13 to 15	----- (not used)
AL-16 to 23	An arithmetic circuit and a peripheral circuit part are abnormal.
No display	Abnormality is generated in ROM.

6. REPLACEMENT METHOD OF FUSE AND PCB

When replacing PCB, re-mount 2 ROM's and NV RAM (parameter memory element) on a new PCB. For other settings and speed rpm adjustment, for example, do this as needed. For others, refer to item 6 in Chapter I in this manual.

7. SPINDLE ORIENTATION CONTROL CIRCUIT

Refer to item 7 in Chapter I in this manual for the maintenance of the spindle orientation control circuit and the adjustment. Please refer to the appendix for other maintenance.

APPENDIXES

APPENDIX 1 CONNECTION DIAGRAMS

- Fig. 1 (a) Connection diagram of MODEL 1/2/small MODEL 3
- Fig. 1 (b) Connection diagram of MODEL 3 ~ 22
- Fig. 1 (c) Connection diagram of MODEL 30, 40
- Fig. 1 (d) Connection diagram of AC spindle servo unit (380V/415VAC input)
- Fig. 1 (e) Connection diagram of spindle orientation (with position coder employed)
- Fig. 1 (f) Detailed connection diagram of spindle orientation with position coder employed (when the synchronous feed is combined with a turning machine, machining center, etc.)
- Fig. 1 (g) Detailed connection diagram of spindle orientation using position coder (when the spindle orientation only is used with the machining center)
- Fig. 1 (h) Detailed connection diagram of spindle orientation using position coder (when the stop position is externally set)
- Fig. 1 (i) Connection diagram of spindle orientation (when magnetic sensor is used)
- Fig. 1 (j) Detailed connection diagram of spindle orientation using magnetic sensor)

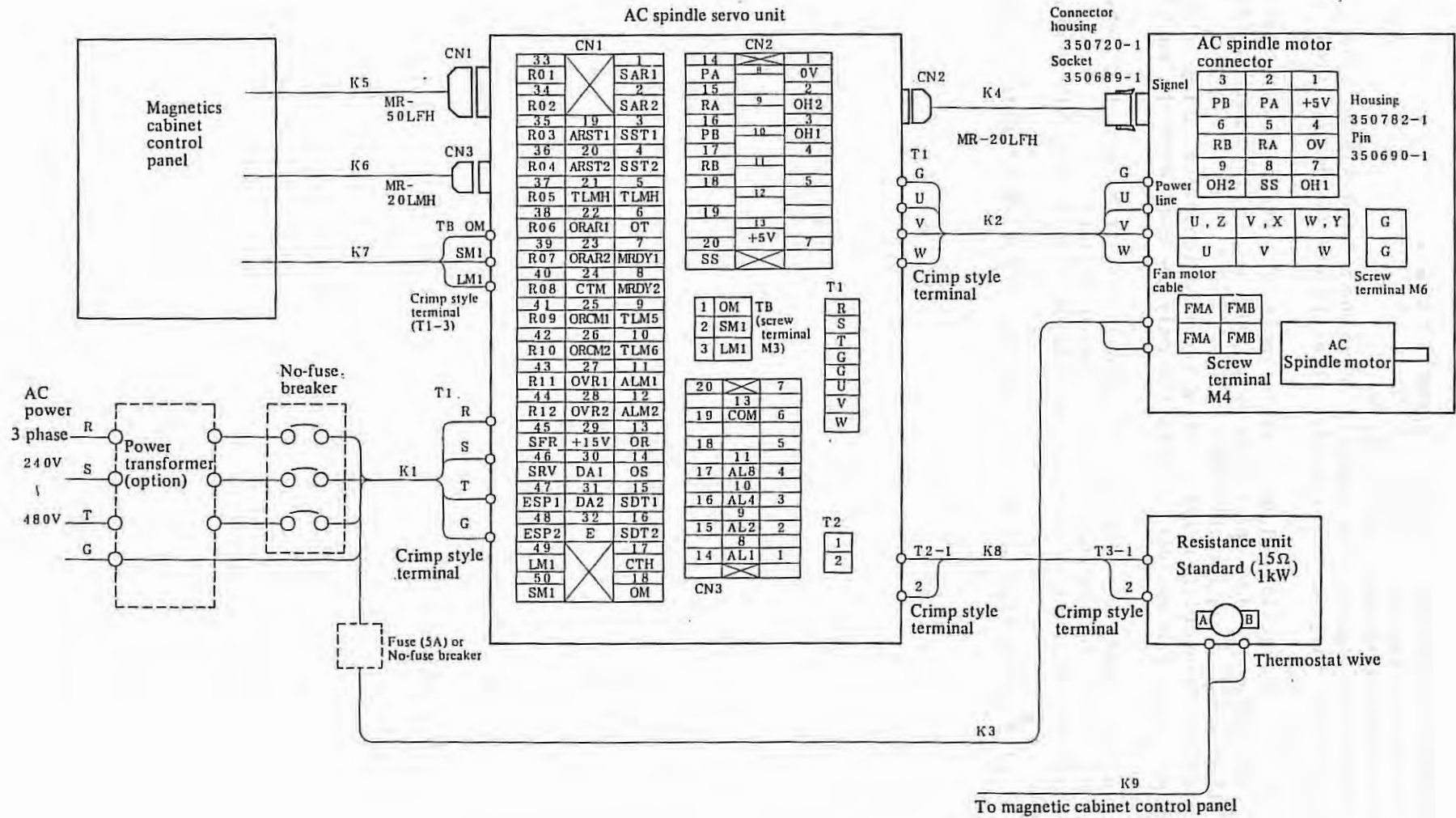

Table 1 (a) Connection diagram of MODEL 1/2/small MODEL 3

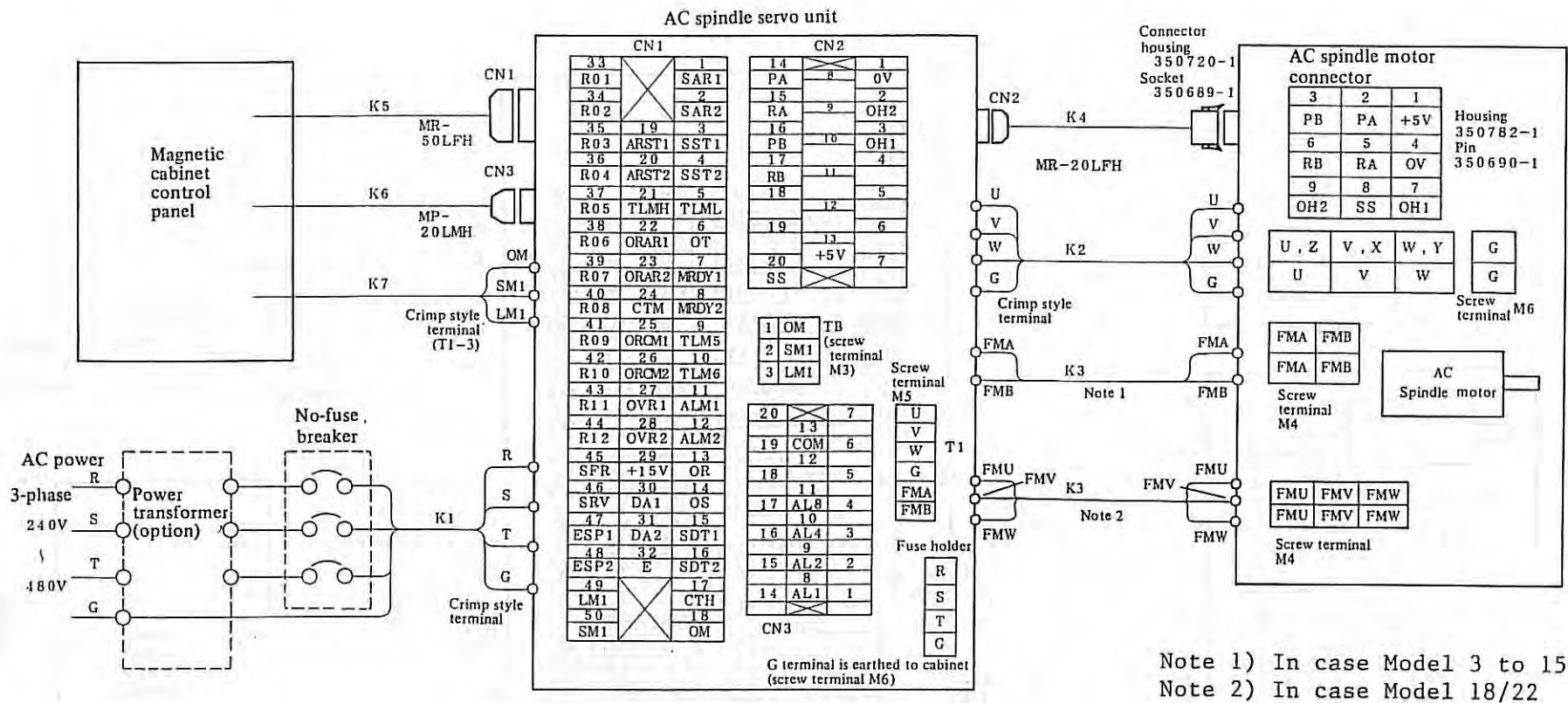

Fig. 1 (b) Connection diagram of MODEL 3 ~ 22

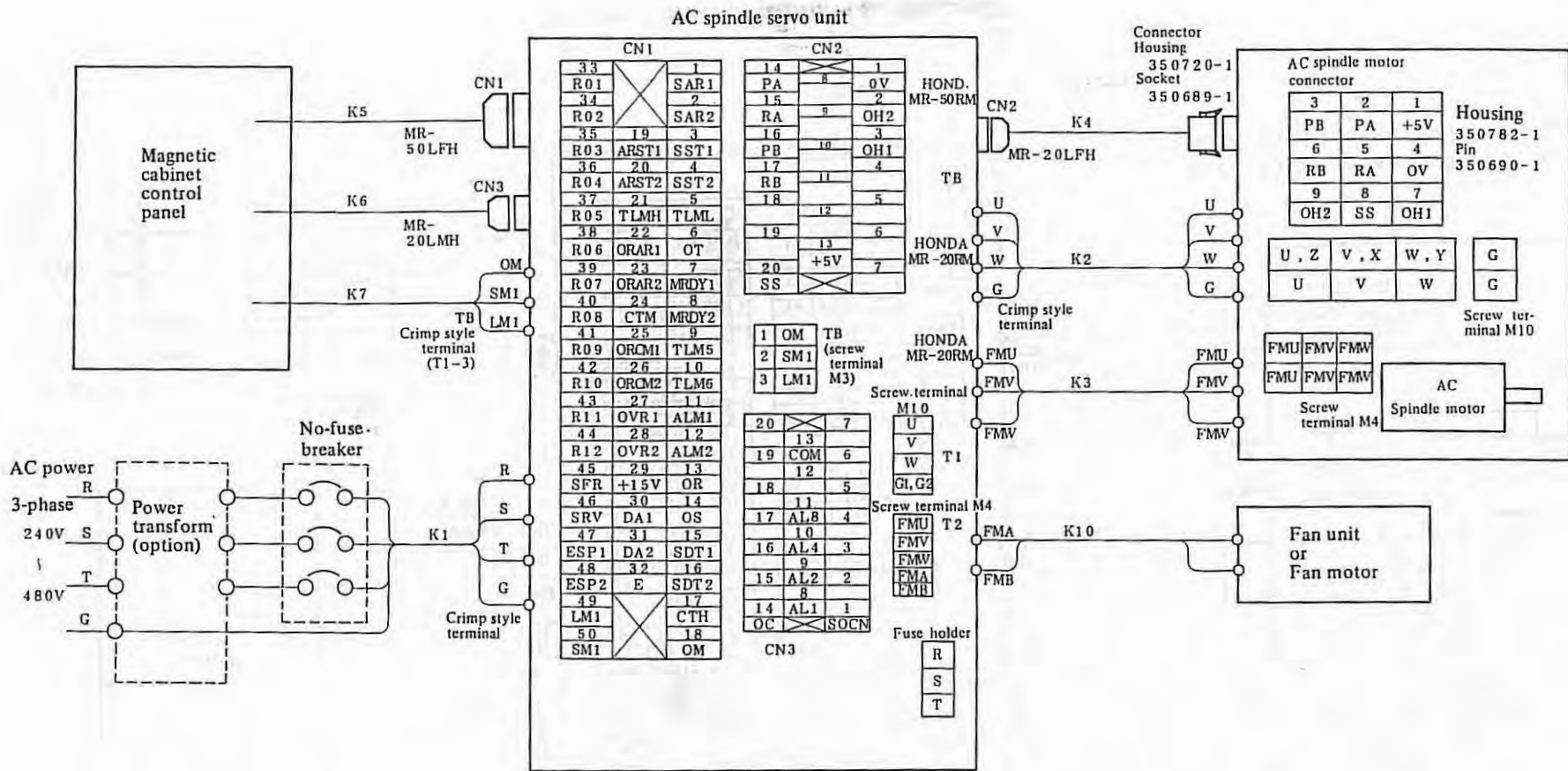

Fig. 1 (c) Connection diagram of MODEL 30, 40

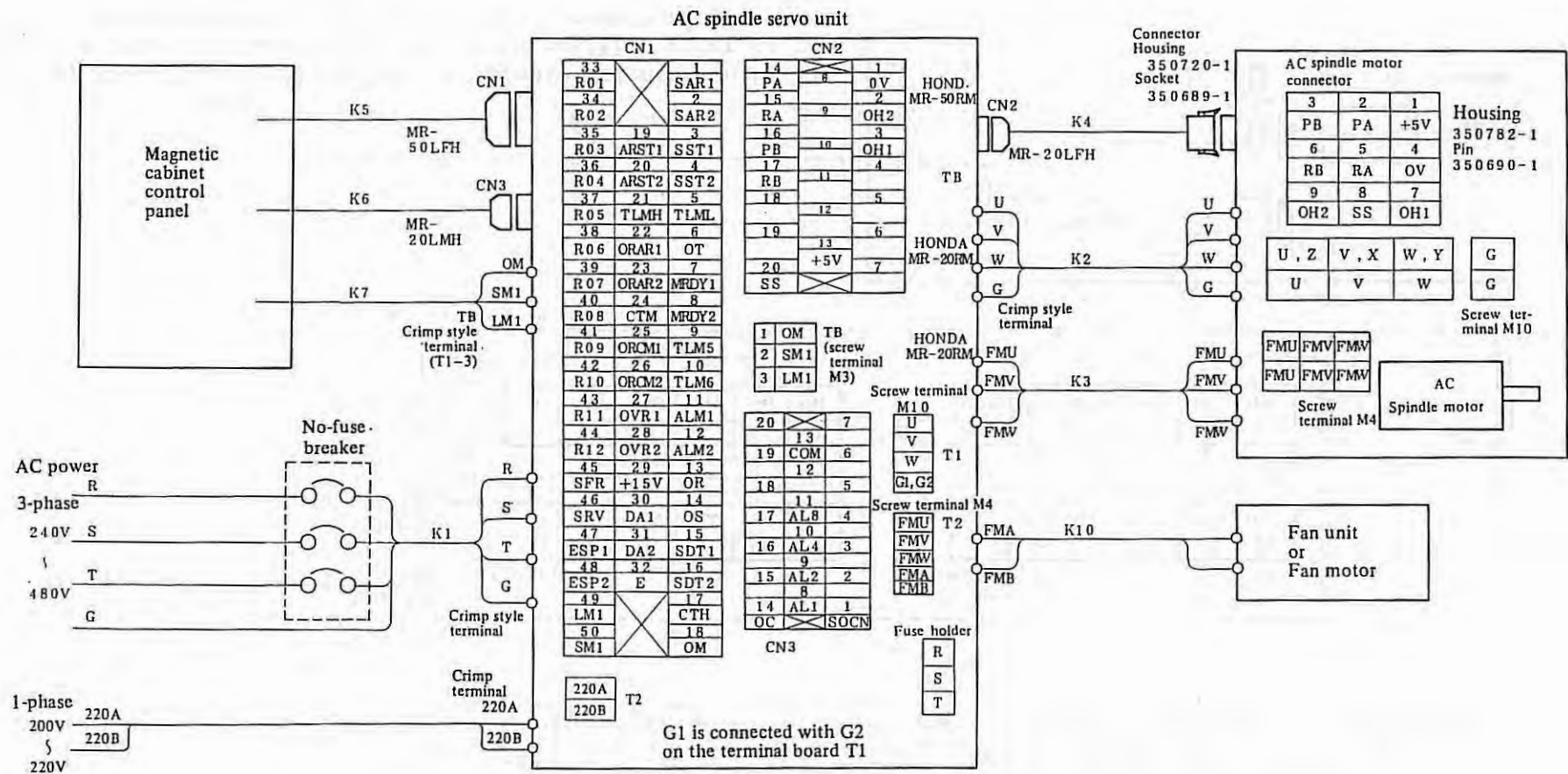
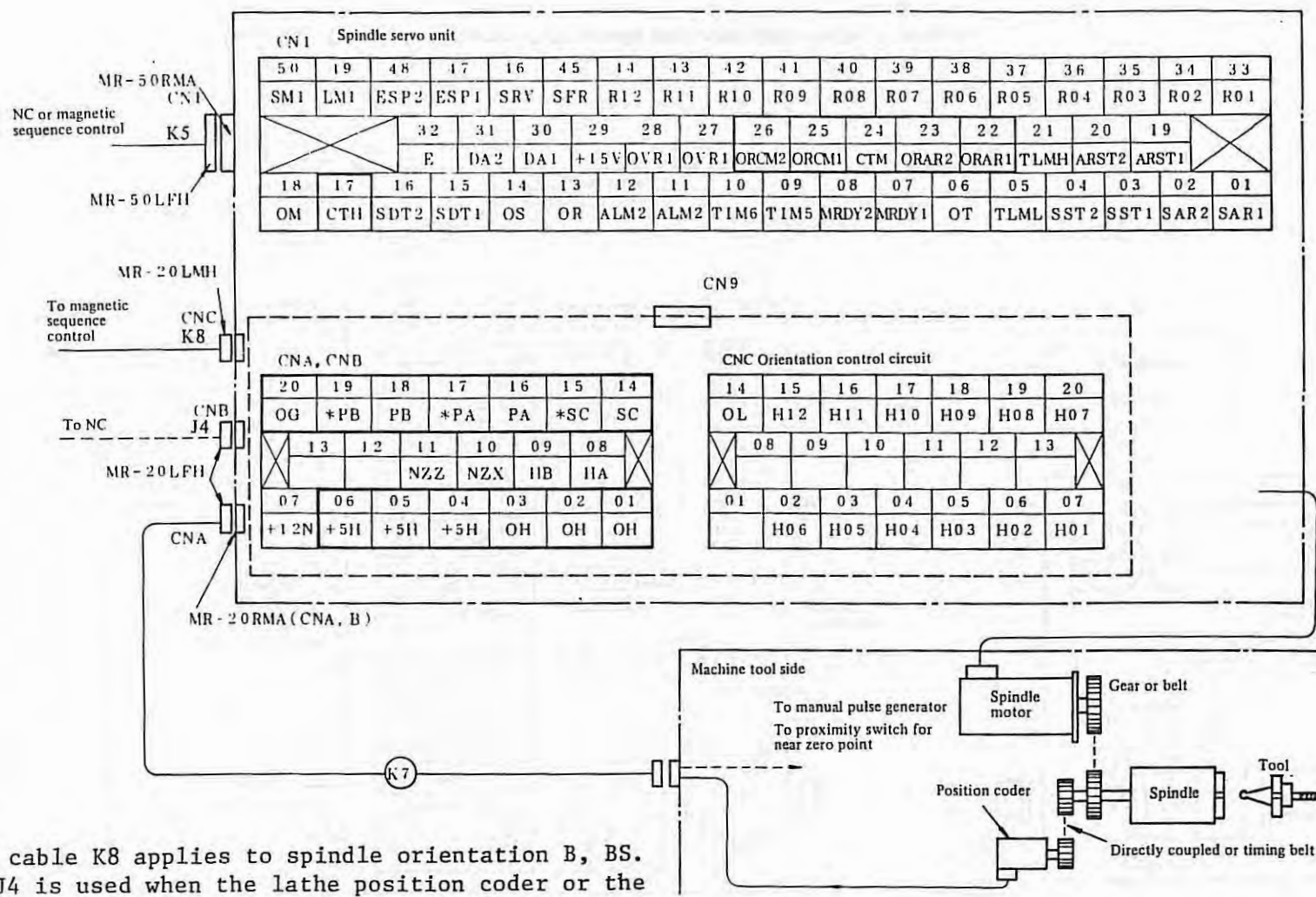

Fig. 1 (d) Connection diagram of AC spindle servo unit (380V/415V AC input)



Note 1) Signal cable K8 applies to spindle orientation B, BS.
 Note 2) Cable J4 is used when the lathe position coder or the synchronous feed position coder for machining center is used concurrently.

Fig. 1 (e) Connection diagram of spindle orientation (with position coder employed)

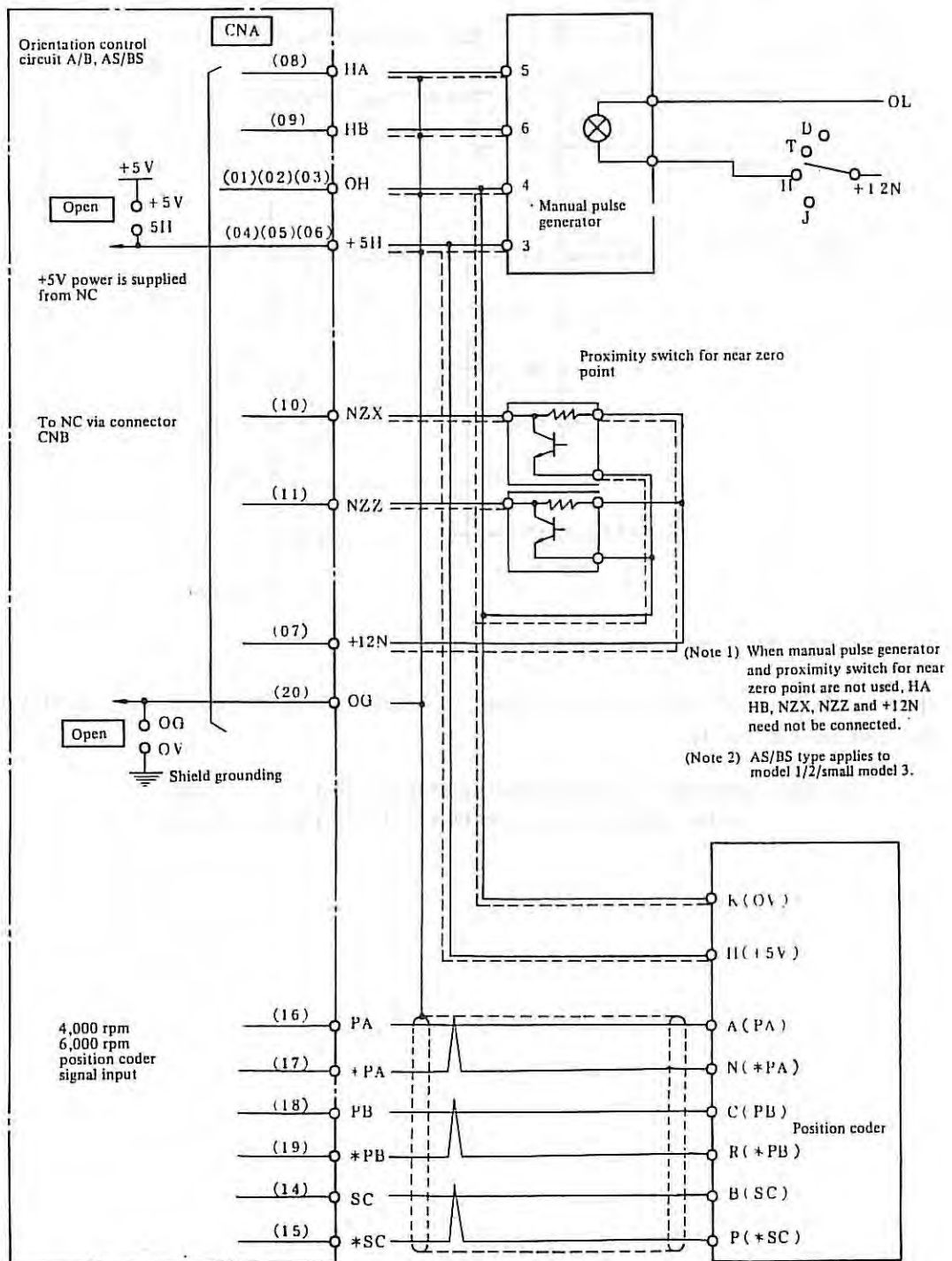
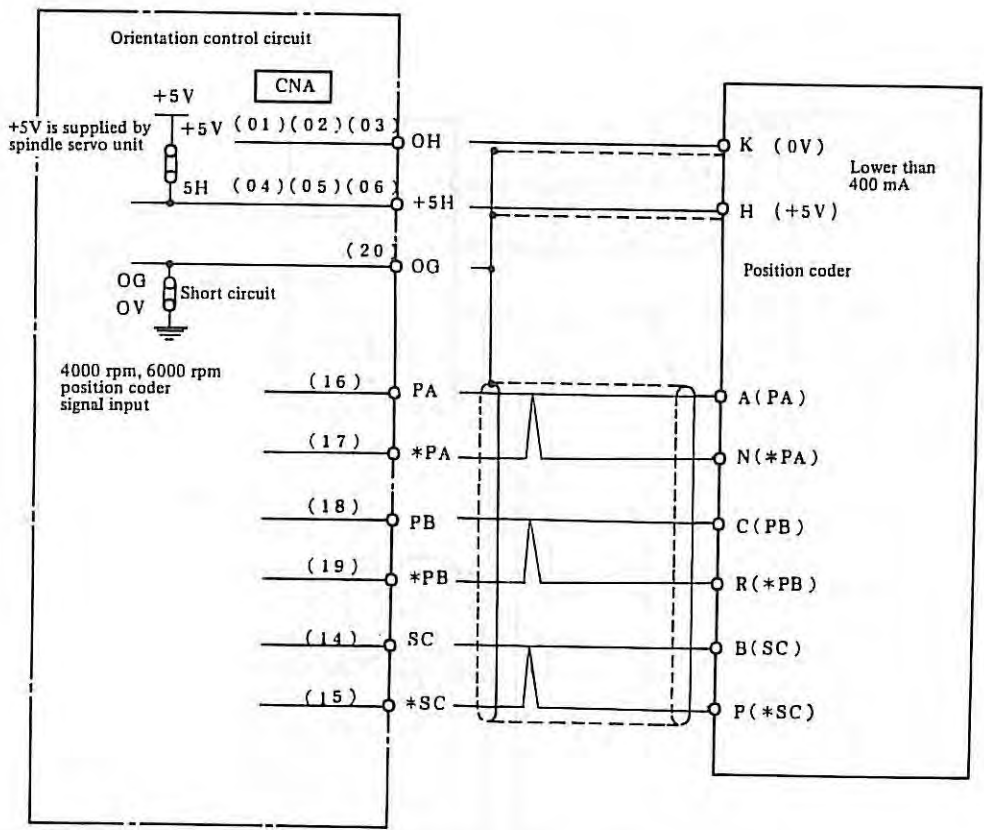

Fig. 1 (f) Detailed connection diagram of spindle orientation with position coder employed (when synchronous feed is combined with turning machine and machining centers etc)



Note) The cable length should be shorter than 20 m between the servo unit and the position coder.

Fig. 1 (g) Detailed connection diagram of spindle orientation using position coder (when spindle orientation only is used for machining centers)

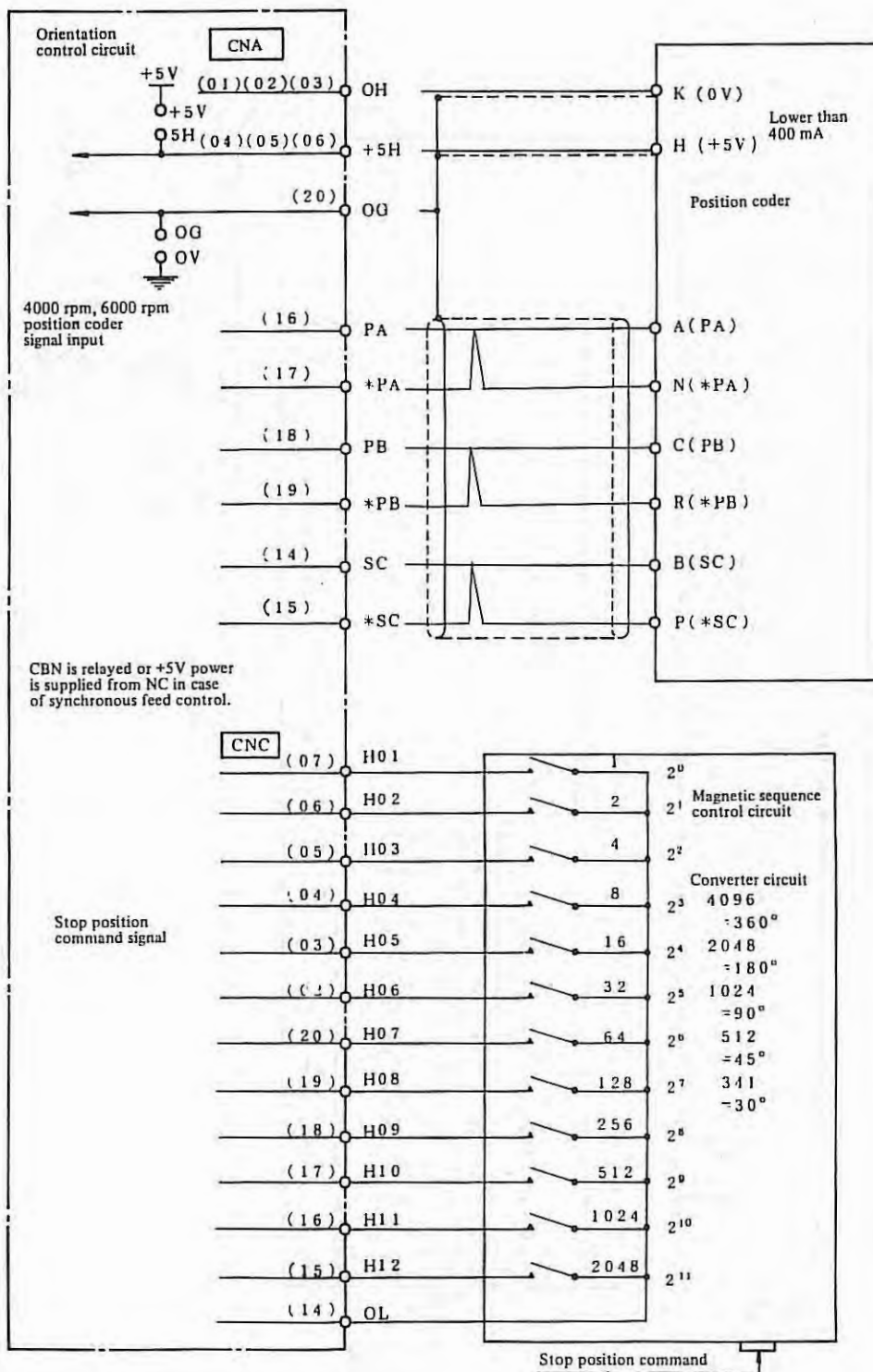

Fig. 1 (h) Detailed connection diagram of spindle orientation using position coder (when the stop position is externally set)

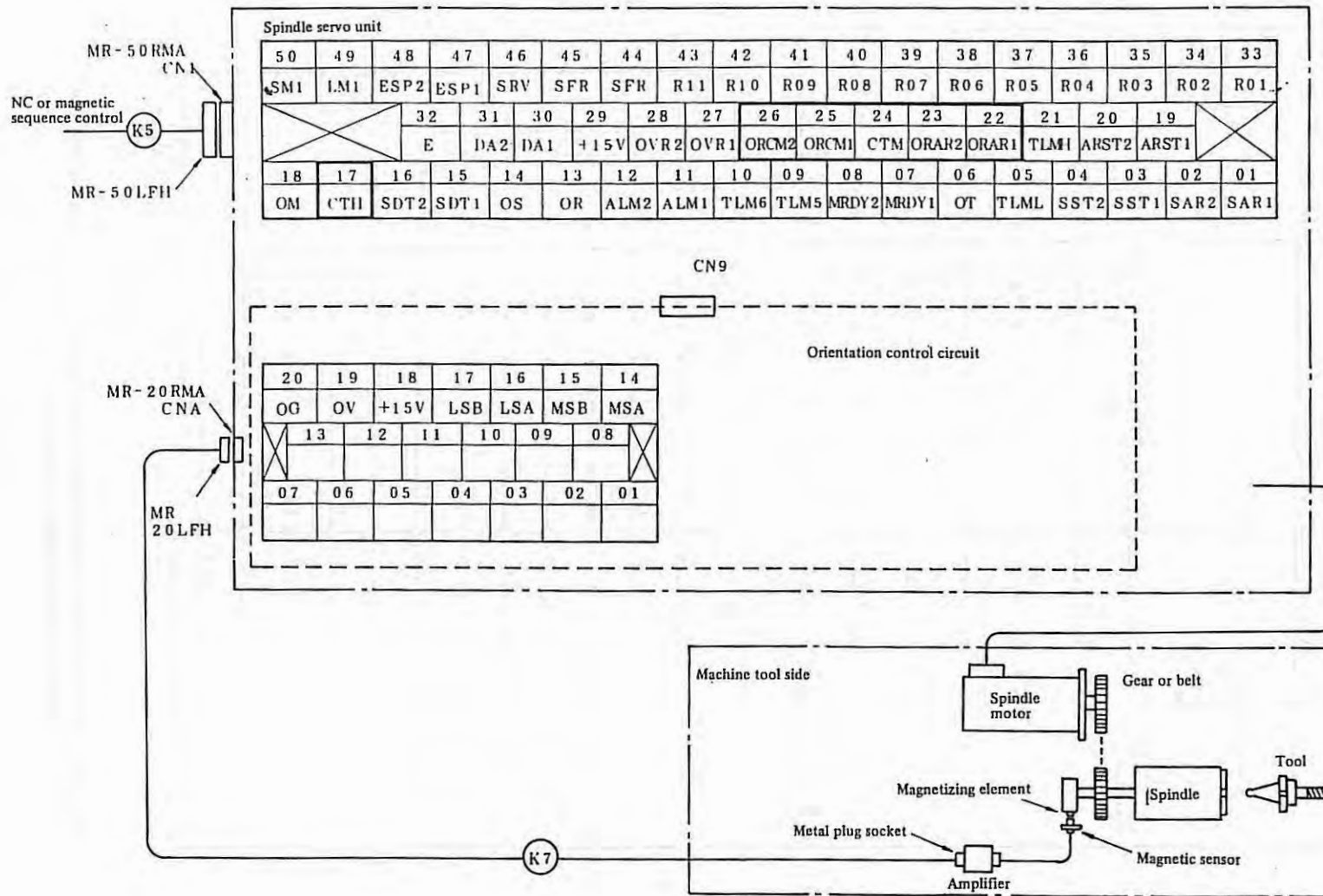
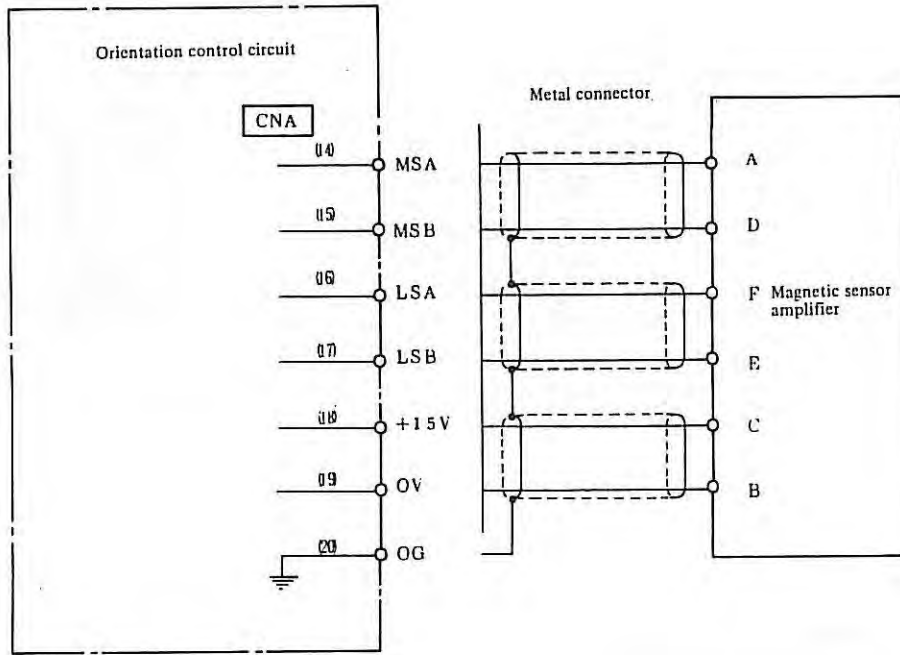

Fig. 1 (i) Connection diagram of spindle orientation (when magnetic sensor is used)



(Note) The cable length should be shorter than 20m between the servo unit and the magnetic sensor amplifier.

Fig. 1 (j) Detailed connection diagram of spindle orientation (when magnetic sensor is used)

APPENDIX 2 CABLE ENTRANCE DIAGRAM

1) MODEL 1/2/small MODEL 3
cable entrance diagram
(A06B-6052-H001,H002,H003)

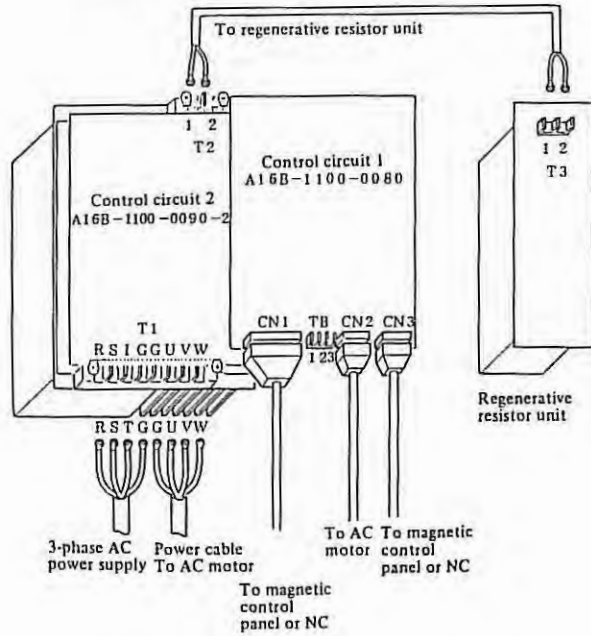

2) MODEL 3, 6 cable entrance
diagram
(A06B-6044-H103,106)

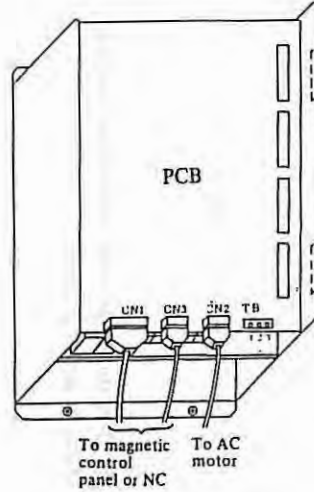

3) MODEL 8, 12 cable entrance
diagram
(A06B-6044-H108,H112)

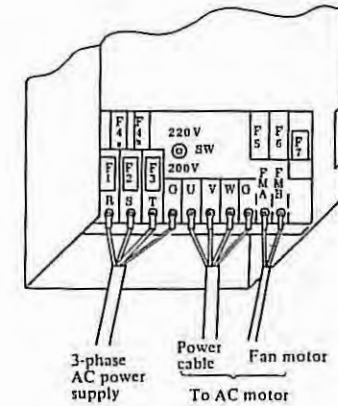
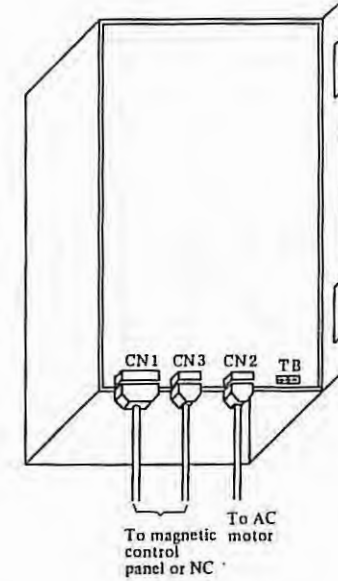

4) MODEL 8, 12, 15 cable entrance diagram
(A06B-6044-H009, H010, H011, H023)

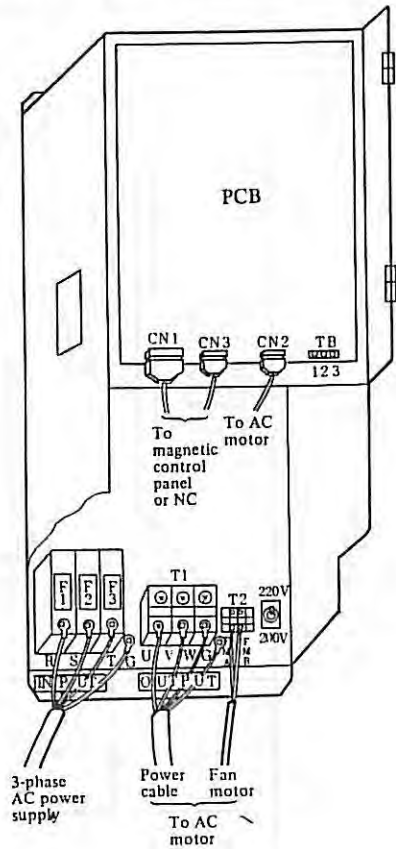

5) MODEL 18, 22 cable entrance diagram

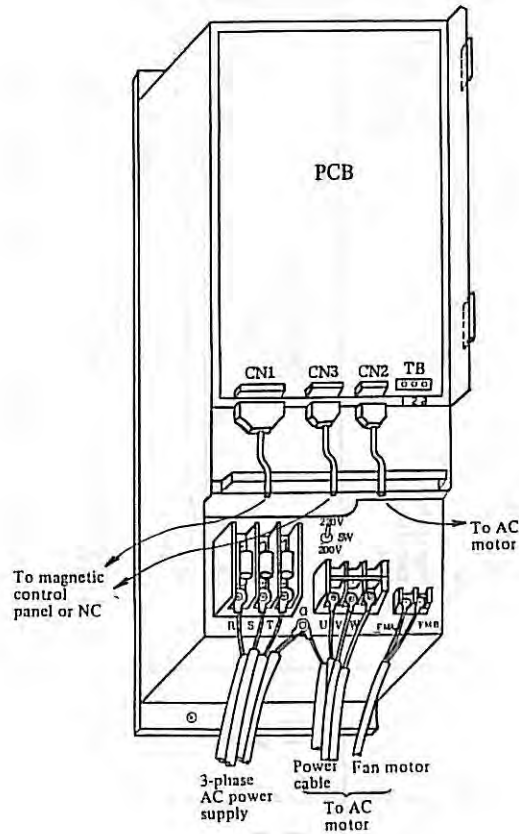

6) MODEL 30, 40 cable entrance diagram

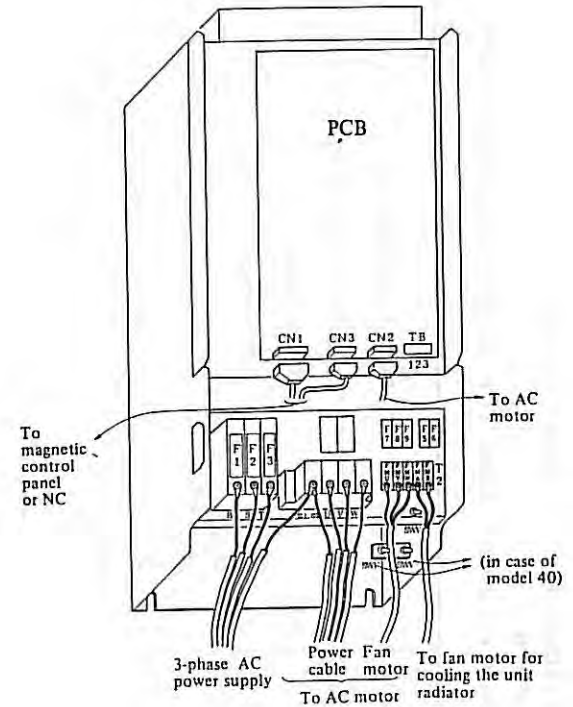



APPENDIX 3 CABLE SPECIFICATIONS

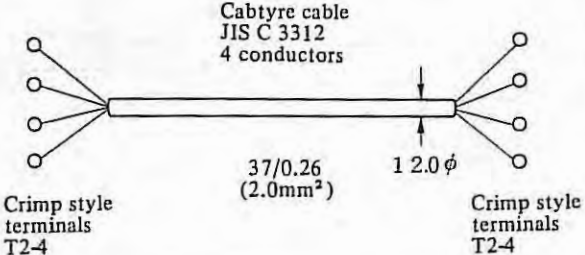
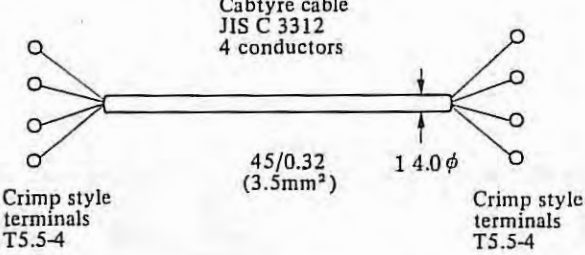
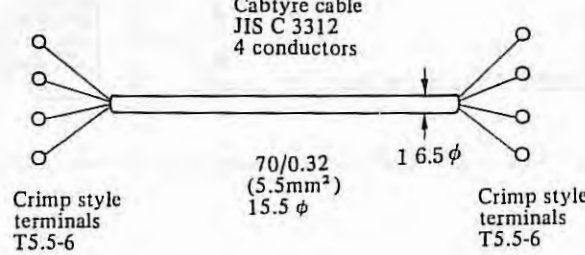
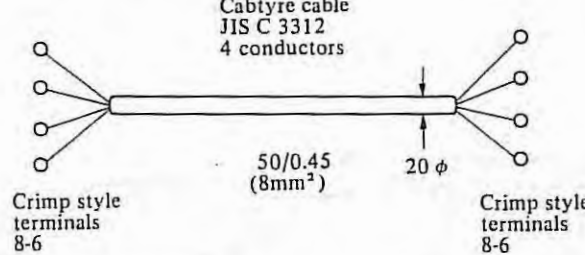
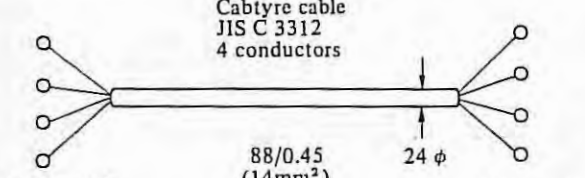

The cable specifications are as shown below.

Prepare cables by users.

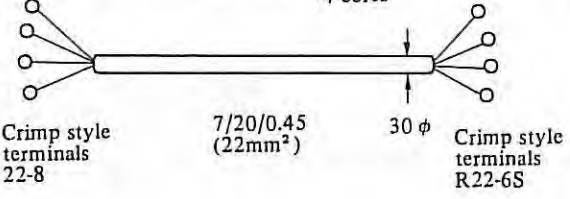
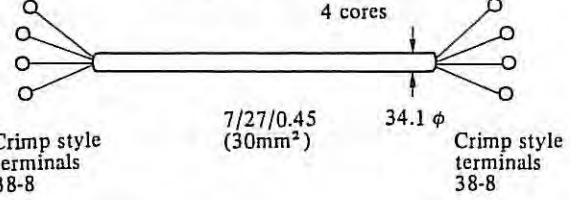
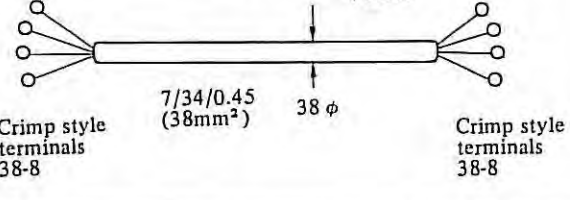
1) Power line and motive power line for respective motor models

Use	Symbol	Specifications	FANUC specification No.
For MODEL 1 (Lower than 5 KVA)	K1 K2	 <p>Cabtyre cable JIS C 3312 4 conductors</p> <p>37/0.26 (2.0mm²)</p> <p>12.0φ</p> <p>Crimp style terminals T2-4</p>	
For MODEL 2 (Lower than 7 KVA)	K1 K2	 <p>Cabtyre cable JIS C 3312 4 conductors</p> <p>45/0.32 (3.5mm²)</p> <p>14.0φ</p> <p>Crimp style terminals T5.5-4</p>	
For MODEL 3 (Lower than 12 KVA)	K1 K2	 <p>Cabtyre cable JIS C 3312 4 conductors</p> <p>70/0.32 (5.5mm²) 15.5φ</p> <p>16.5φ</p> <p>Crimp style terminals T5.5-6</p>	A02B-0008-K853 7 m long
For MODEL 6 (Lower than 16 KVA)	K1 K2	 <p>Cabtyre cable JIS C 3312 4 conductors</p> <p>50/0.45 (8mm²)</p> <p>20φ</p> <p>Crimp style terminals 8-6</p>	A02B-0008-K854 7 m long
For MODEL 8, 12 (Lower than 25 KVA)	K1	 <p>Cabtyre cable JIS C 3312 4 conductors</p> <p>88/0.45 (14mm²)</p> <p>24φ</p> <p>Crimp style terminals 14-6</p>	A06B-6044-K017 7 m long
	K2	<p>Crimp style terminals 14-6 (K2: Motive power line) 14-8 (K1: Power line)</p>	A06B-6044-K018 7 m long

Use	Symbol	Specifications	FANUC specification No.
For MODEL 15 (Lower than 30 KVA)	K1 K2	<p style="text-align: center;">Heat-proof vinyl cabtyre cable</p> <p style="text-align: center;">4 cores</p>  <p style="text-align: center;">7/20/0.45 (22mm²)</p> <p style="text-align: center;">30 φ</p> <p>Crimp style terminals 22-8 Crimp style terminals R22-6S</p>	A06B-6044-K019 7 m long
For MODEL 18 (Lower than 38 KVA)	K1 K2	<p style="text-align: center;">Heat-proof vinyl cabtyre cable</p> <p style="text-align: center;">4 cores</p>  <p style="text-align: center;">7/27/0.45 (30mm²)</p> <p style="text-align: center;">34.1 φ</p> <p>Crimp style terminals 38-8 Crimp style terminals 38-8</p>	A06B-6044-K020 7 m long
For MODEL 22 (Lower than 45 KVA)	K1 K2	<p style="text-align: center;">Heat-proof vinyl cabtyre cable</p> <p style="text-align: center;">4 cores</p>  <p style="text-align: center;">7/34/0.45 (38mm²)</p> <p style="text-align: center;">38 φ</p> <p>Crimp style terminals 38-8 Crimp style terminals 38-8</p>	A06B-6044-K021 7 m long
Power cable and power source cable for MODEL 30	K1 K2	<p style="text-align: center;">Heat-proof cable for 600 VAC Single wire (a) x 3 line and (b) x 1 line</p> <p>(a) Conductor</p> <p style="text-align: center;">7/34/0.45 (38mm²) Crimp terminal T38-10</p>  <p>(b) Conductor</p> <p style="text-align: center;">7/20/0.45 (22mm²) Crimp terminal T38-10</p> 	

Use	Symbol	Specifications	FANUC specification No.
Power cable and power source cable for MODEL 40	K1 K2	<p data-bbox="606 340 894 411">Heat-proof cable for 600 VAC Single wire (a) x 3 lines and (b) x 1 line</p> <p data-bbox="512 429 648 455">(a) Conductor</p> <p data-bbox="648 477 868 526">19/20/0.45 (50mm²) Crimp terminal T60-10</p>  <p data-bbox="512 617 648 643">(b) Conductor</p> <p data-bbox="648 665 868 714">7/20/0.45 (22mm²) Crimp terminal T38-10</p> 	

2) Common line

The following cables are common to each model.

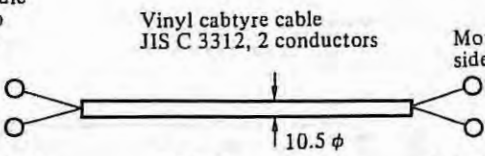
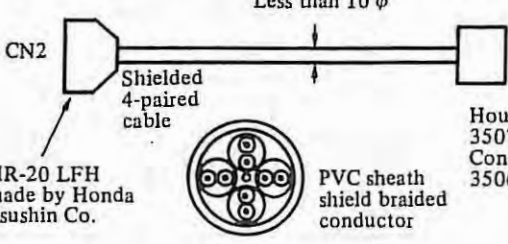
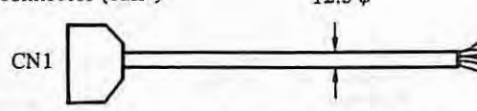
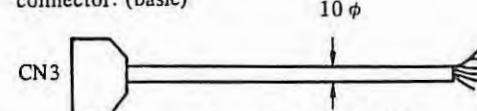
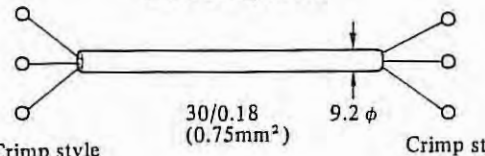
Use	Symbol	Specifications	FANUC specification No.
<p>Spindle servo unit</p> <p>AC spindle motor (cooling fan) (Except Model 18,22,30,40)</p>	K3	<p>Spindle servo unit side</p> <p>Vinyl cabtyre cable JIS C 3312, 2 conductors</p> <p>Motor side</p>  <p>Crimp style terminals T2-5</p> <p>37/0.26 (2mm²)</p> <p>10.5 φ</p> <p>Crimp style terminals T2-5</p>	<p>A06B-6044-K022</p> <p>7 m long</p>
<p>Spindle servo unit</p> <p>AC spindle motor (for signal)</p>	K4	<p>Spindle servo unit option connector</p> <p>Attached connector of spindle motor</p> <p>Less than 10 φ</p>  <p>CN2</p> <p>Shielded 4-paired cable</p> <p>MR-20 LFH made by Honda Tsushin Co.</p> <p>PVC sheath shield braided conductor</p> <p>Housing 350720-1 Contact 350689-1</p>	<p>A06B-6044-K200</p> <p>7 m long</p>
<p>Spindle servo unit</p> <p>Power magnetic control (for signal)</p>	K5	<p>Spindle servo unit connector (basic)</p> <p>Power magnetic control</p> <p>12.5 φ</p>  <p>CN1</p> <p>MR-50 LFH made by Honda Tsushin Co.</p> <p>Braided shield vinyl cable 50 conductors x 0.2mm² (7/0.18) made by Sanyo Denko</p>	<p>A06B-6044-K023</p> <p>7 m long</p>
<p>Spindle servo unit</p> <p>Power magnetic control (for signal)</p>	K6	<p>Spindle servo unit connector: (basic)</p> <p>10 φ</p>  <p>CN3</p> <p>MR-20 LMH made by Honda Tsushin Co.</p> <p>Shielded 4-paired cable 0.3 mm²</p>	<p>A06B-6044-K024</p> <p>7 m long</p>
<p>Speedmeter load meter</p> <p>AC spindle servo unit (for meter)</p>	K7	<p>Vinyl cabtyre cable JIS C 3312, 3 cores</p>  <p>Crimp style terminal T1-4</p> <p>30/0.18 (0.75mm²)</p> <p>9.2 φ</p> <p>Crimp style terminal T1-4</p>	

3) Others (line used in some models)

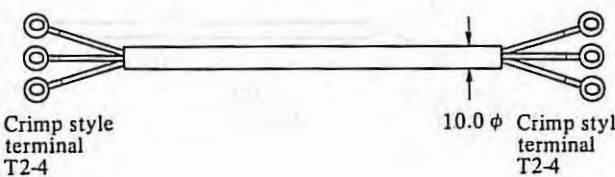
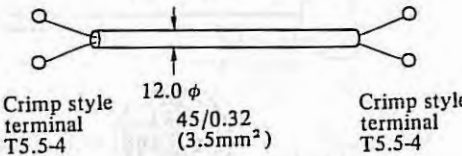
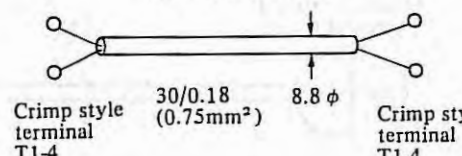
Use	Symbol	Specifications	FANUC specification No.
For motor cooling fan (for MODEL 18,22,30,40)	K3	<p>Vinyl cabtyre cable JIS C 3312, 3 cores</p> <p>Conductor 37/0.26 (2mm²) Outer cover PVC φ10</p>  <p>Crimp style terminal T2-4</p> <p>10.0 φ</p> <p>Crimp style terminal T2-4</p>	
Resistor unit ↓ AC spindle servo unit	K8	<p>Vinyl cabtyre cable JIS C 3312, 2 cores</p>  <p>Crimp style terminal T5.5-4</p> <p>12.0 φ</p> <p>45/0.32 (3.5mm²)</p> <p>Crimp style terminal T5.5-4</p>	
Resistor unit ↓ Power magnetic control (for thermostat)	K9	<p>Vinyl cabtyre cable JIS C 3312, 2 cores</p>  <p>Crimp style terminal T1-4</p> <p>30/0.18 (0.75mm²)</p> <p>8.8 φ</p> <p>Crimp style terminal T1-4</p>	

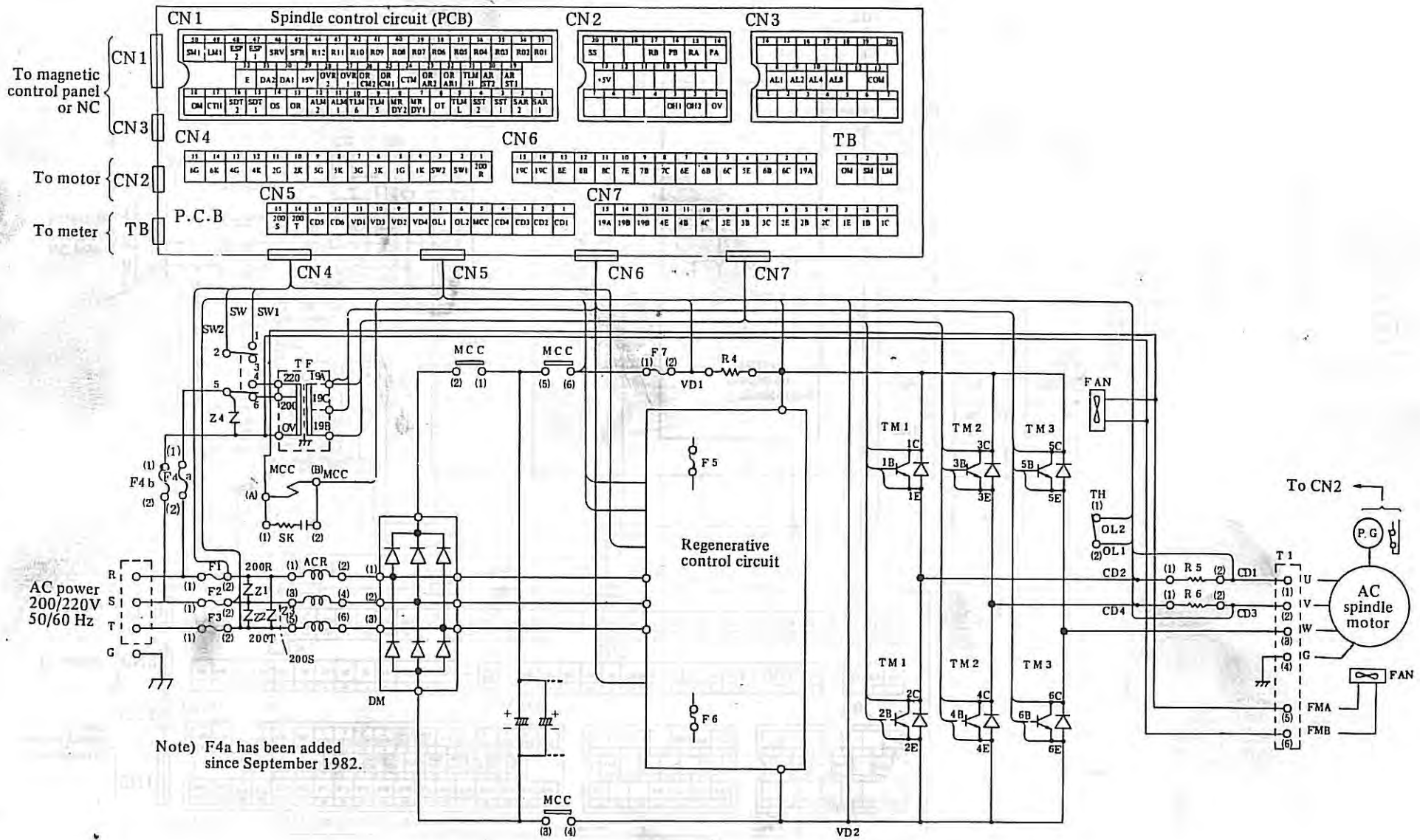

Note) F4a has been added since September 1982.

**APPENDIX 5 MOUNTING LAYOUT OF SPINDLE SERVO UNIT PARTS
(OTHER THAN PCB)**

1) MODEL 1, 2, small MODEL 3 (A06B-6052-H001, -H002, -H003)

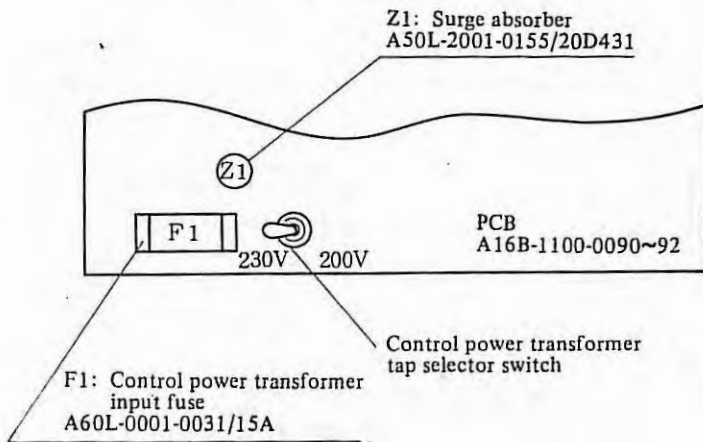
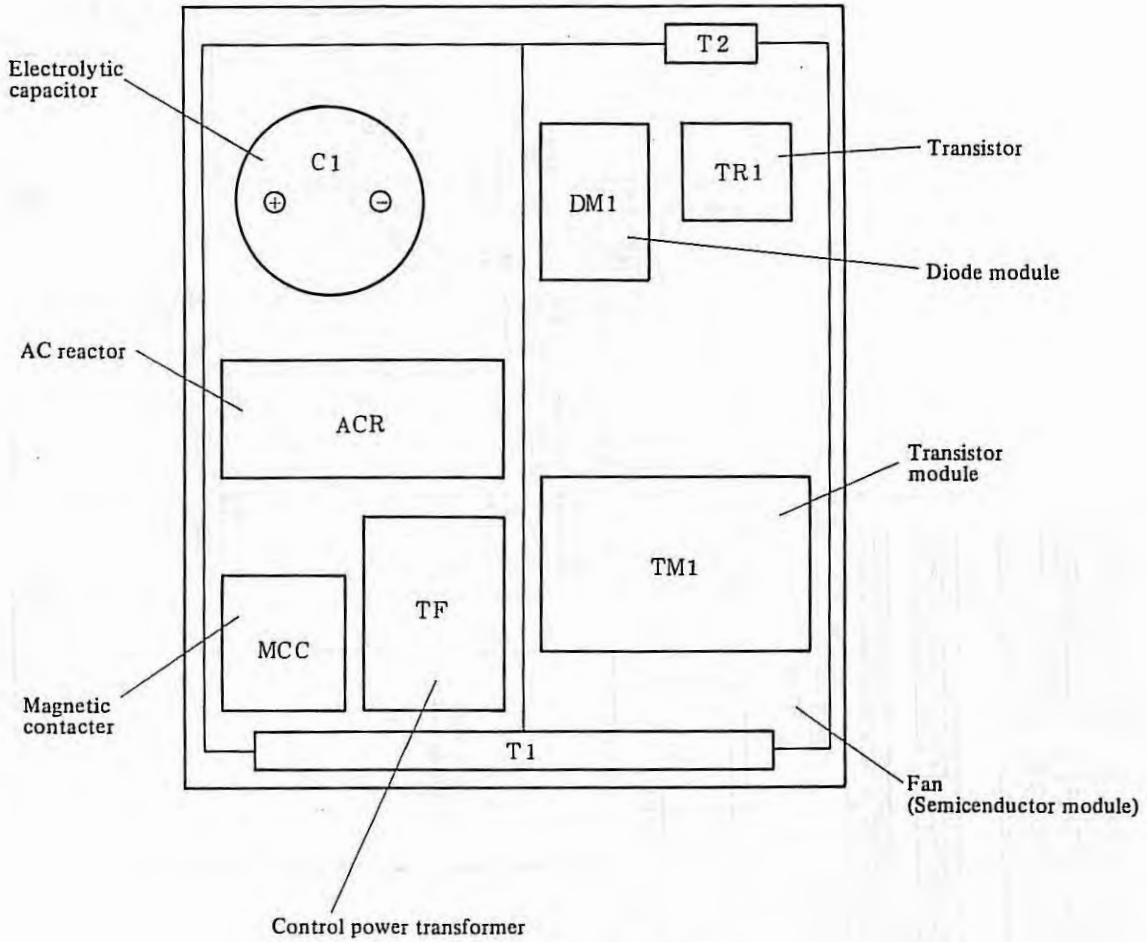

2) Spindle servo unit for AC spindle motor models 3 and 6 (A06B-6044-C008)

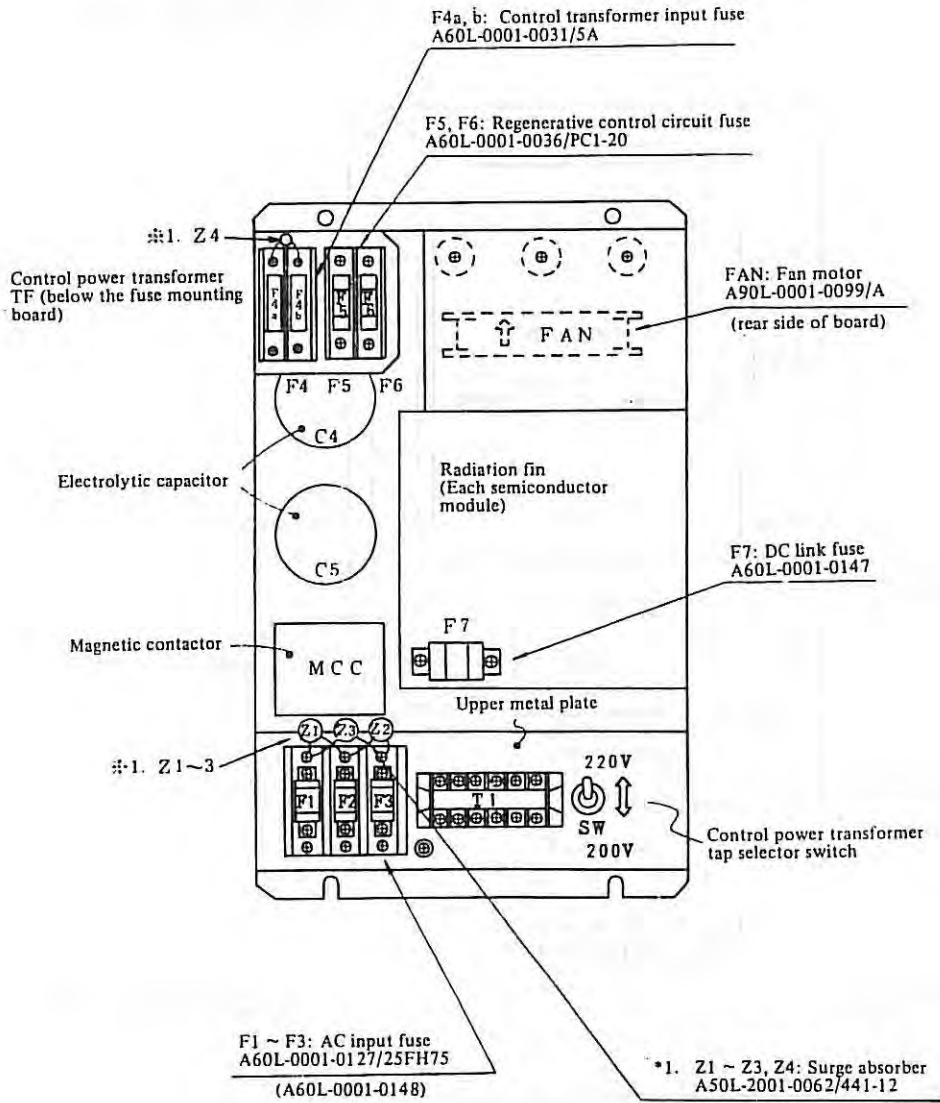

3) MODEL 3, 6 (A06B-6044-H103, H106, H203, H206)

FAN: Fan motor
 A90L-0001-0191 (for model 3)
 A90L-0001-0099/A (for model 6)

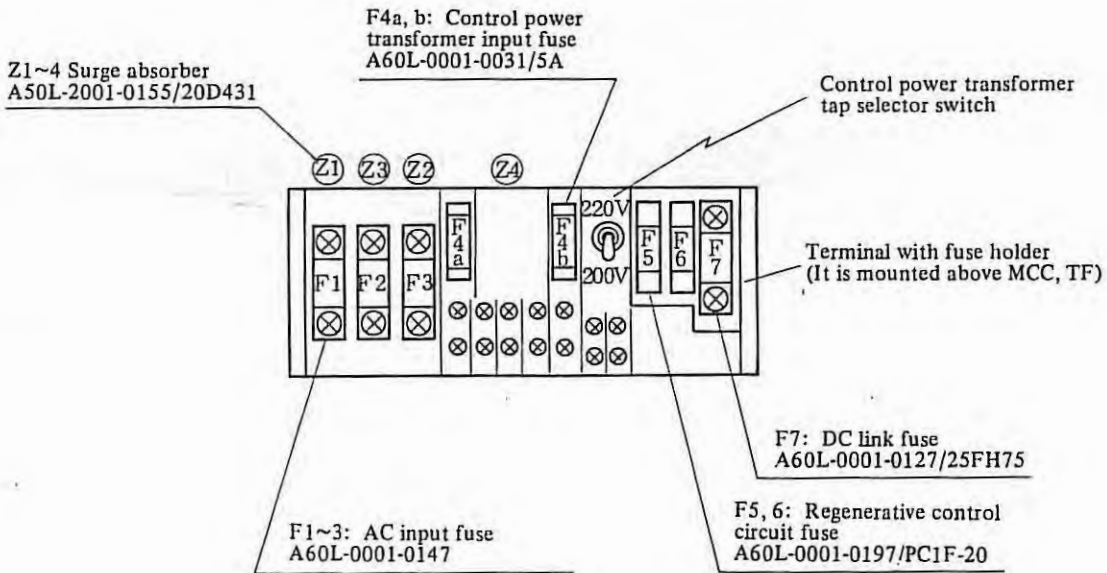
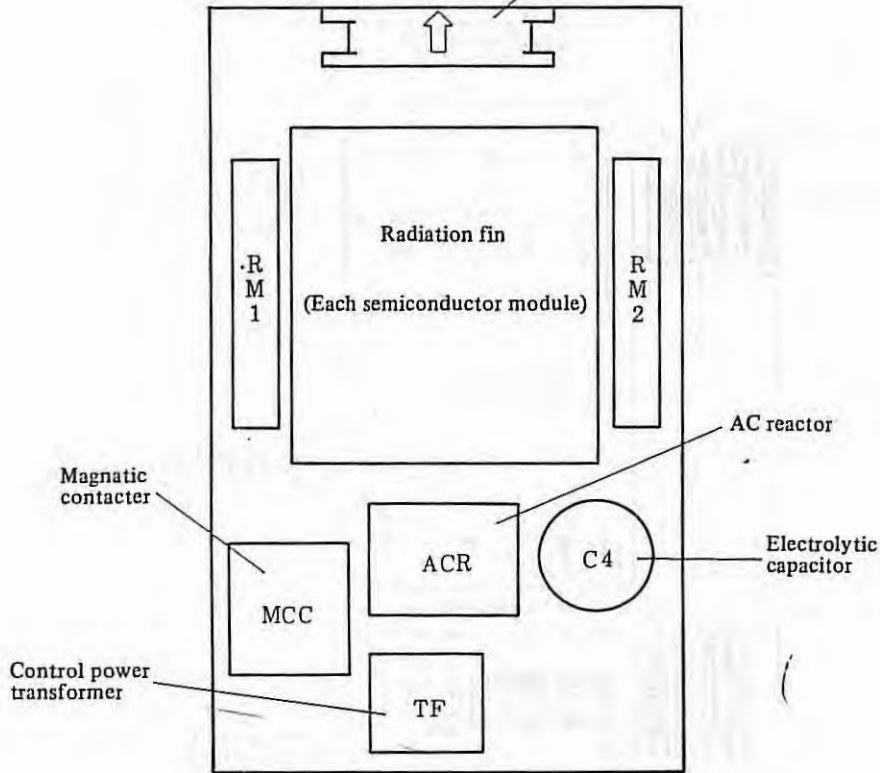

4) Spindle servo unit for AC spindle motor models 8 and 12
(A06B-6044-C009, C010)

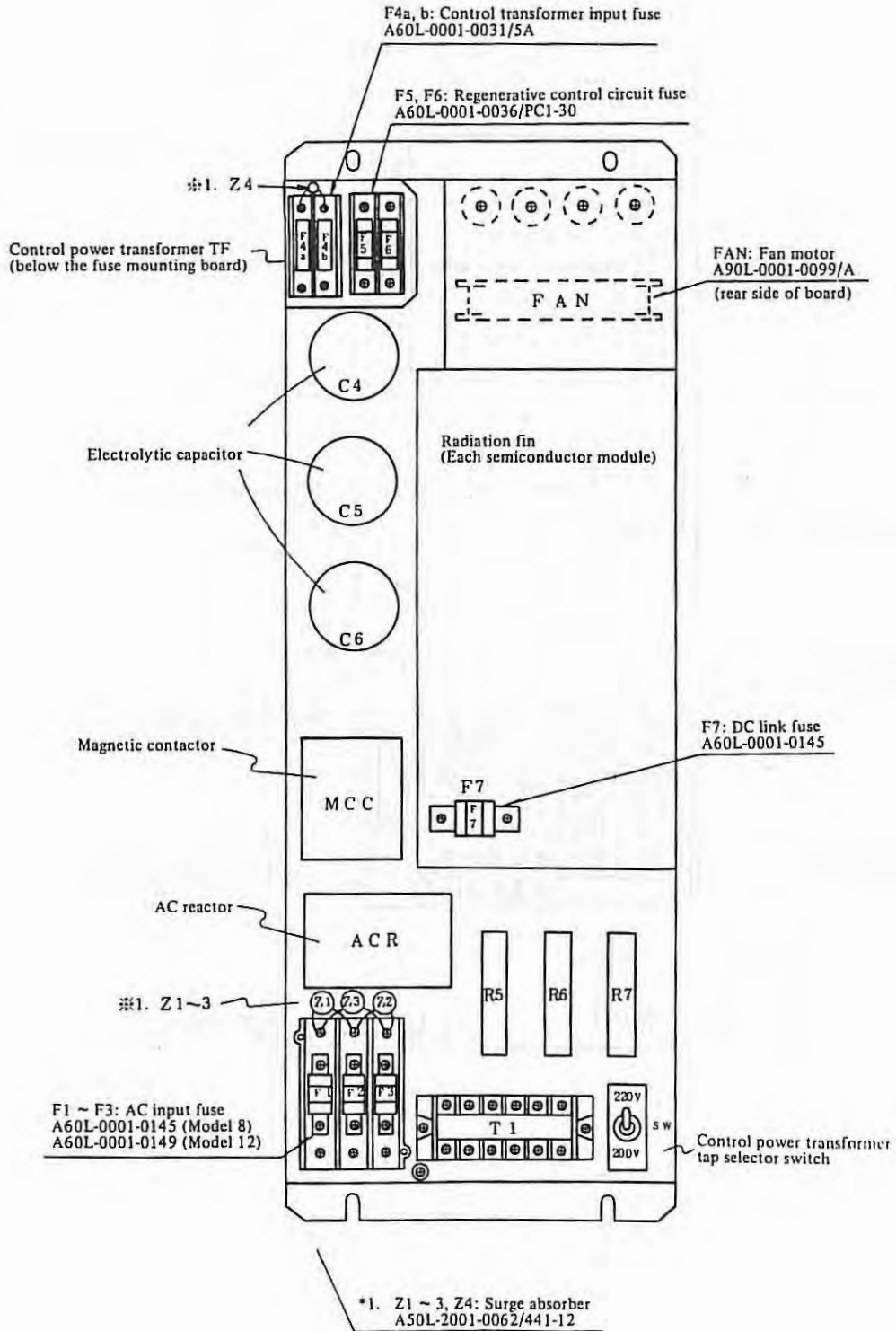

5) MODEL 8, 12 (A06B-6044-H108, H112, H208, H212)

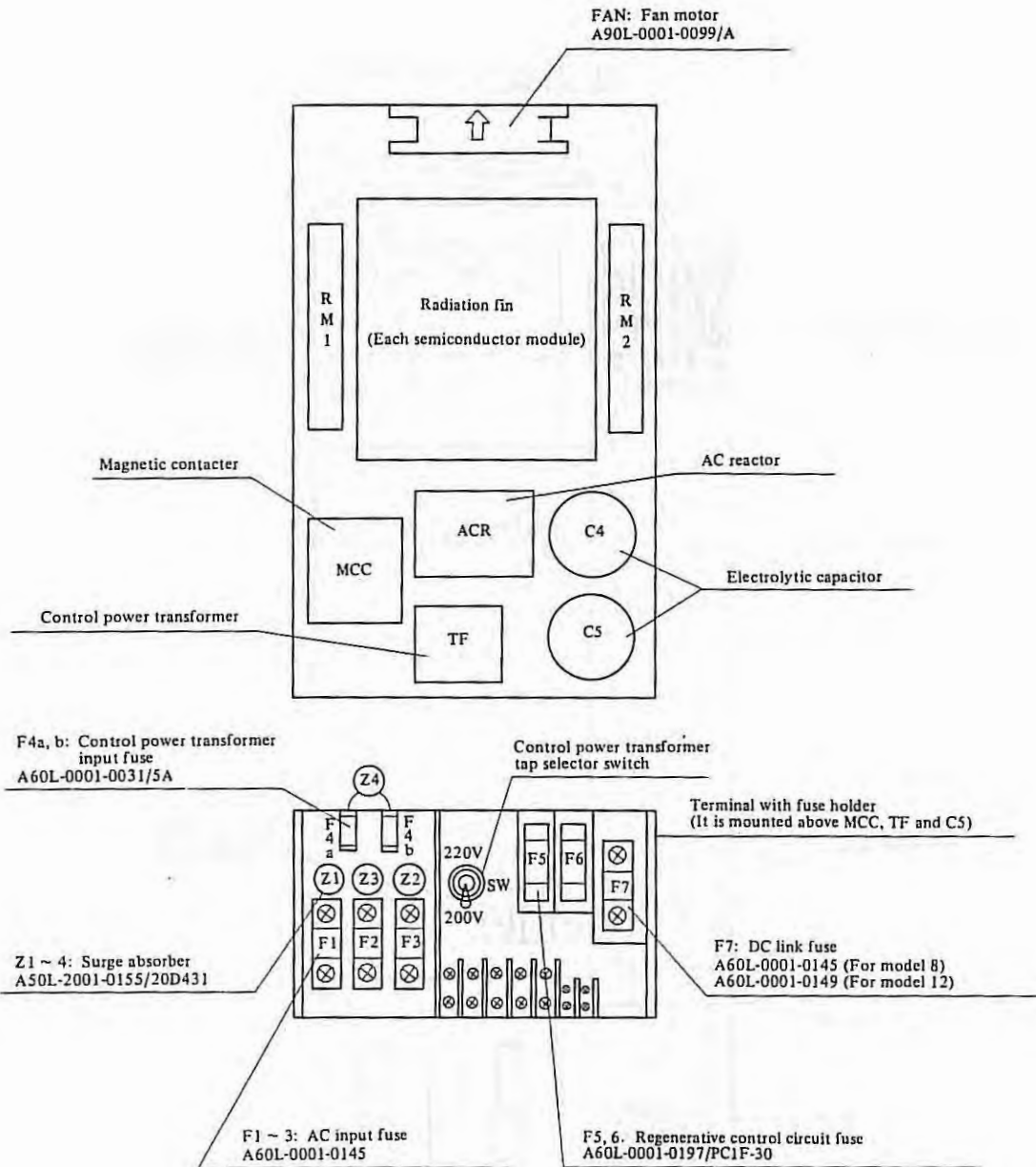

6) MODEL 15 (A06B-6044-H011)

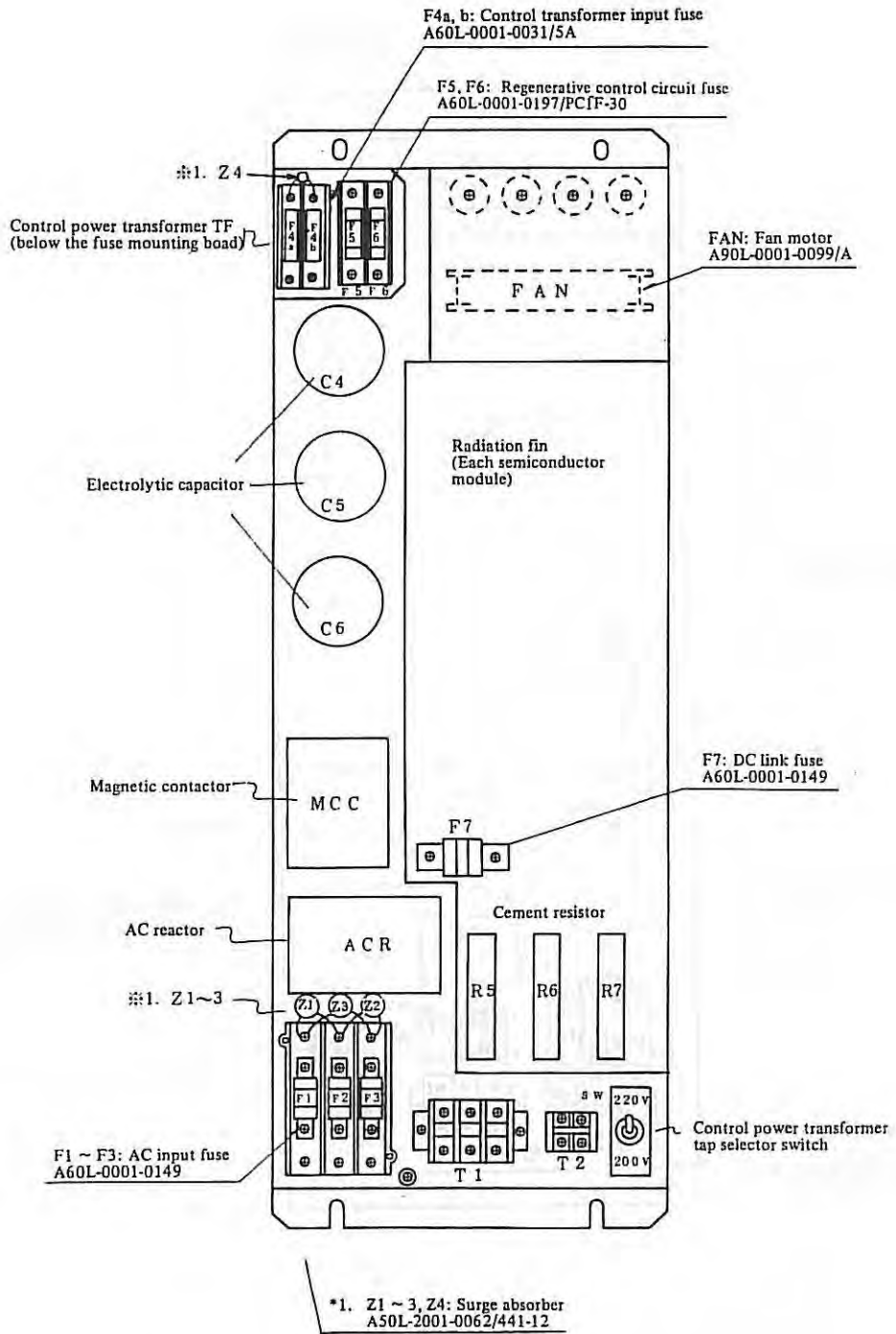

7) MODEL 18, 22 (A06B-6044-H016, H017)

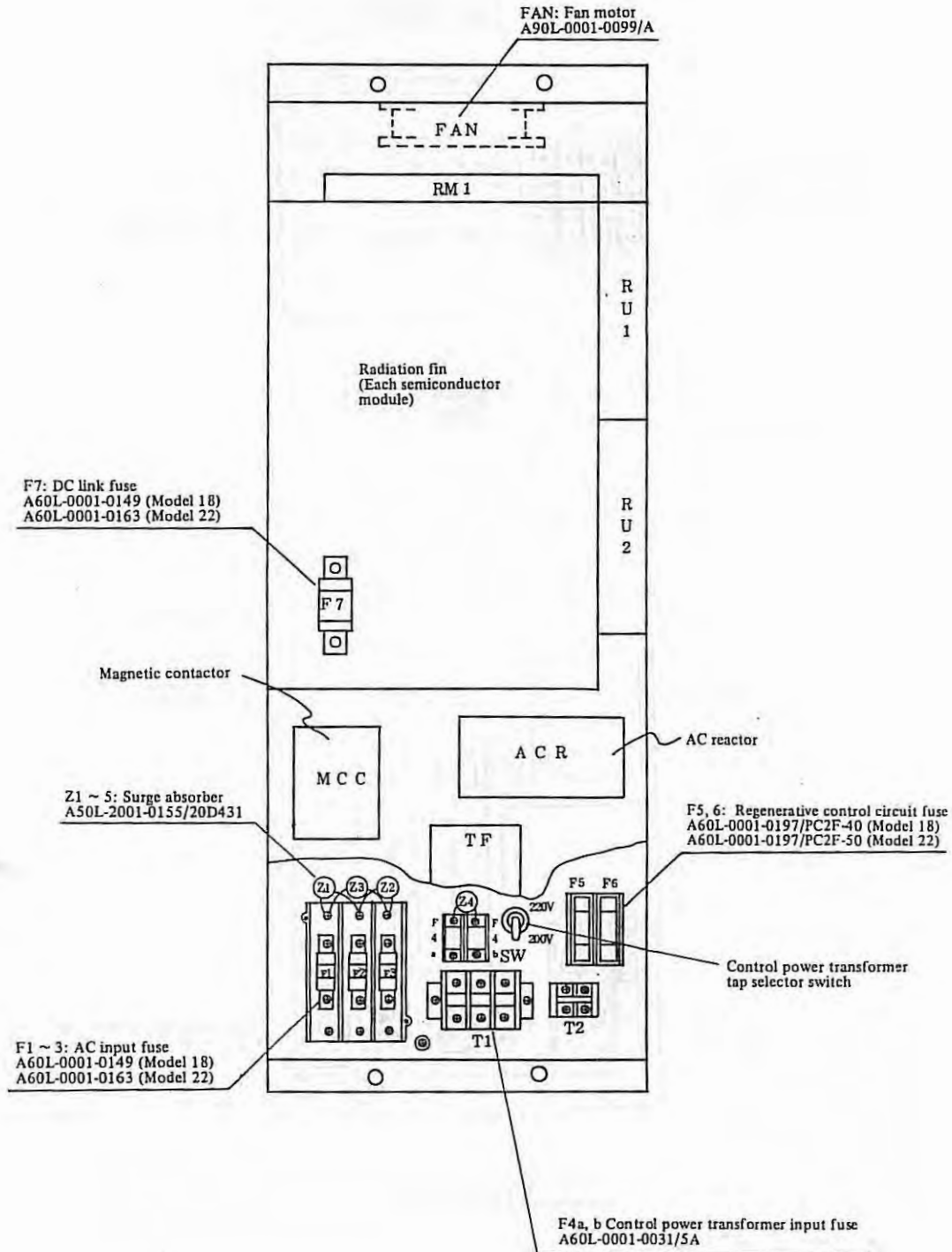

8) MODEL 30 (A06B-6044-H130)

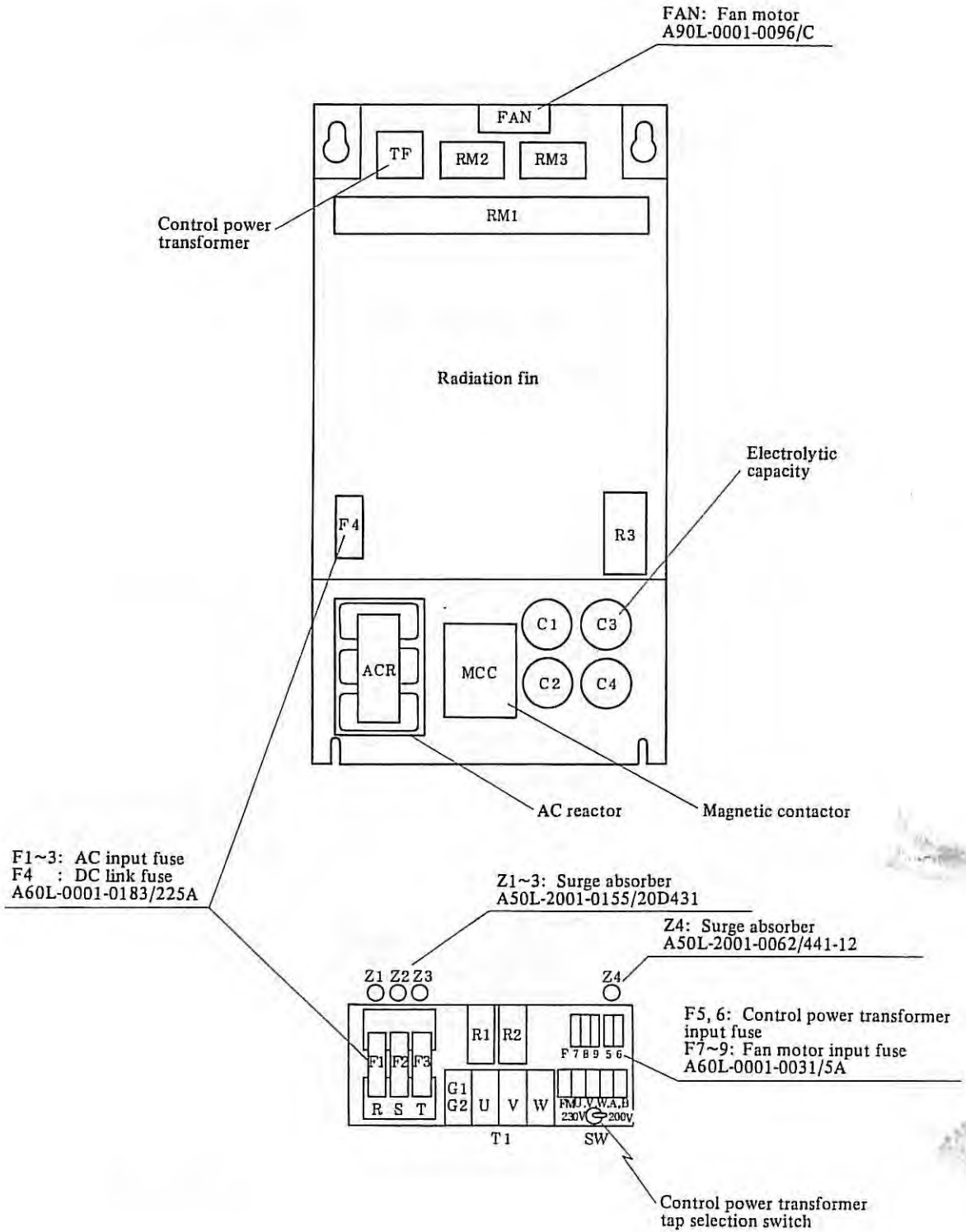

9) MODEL 40

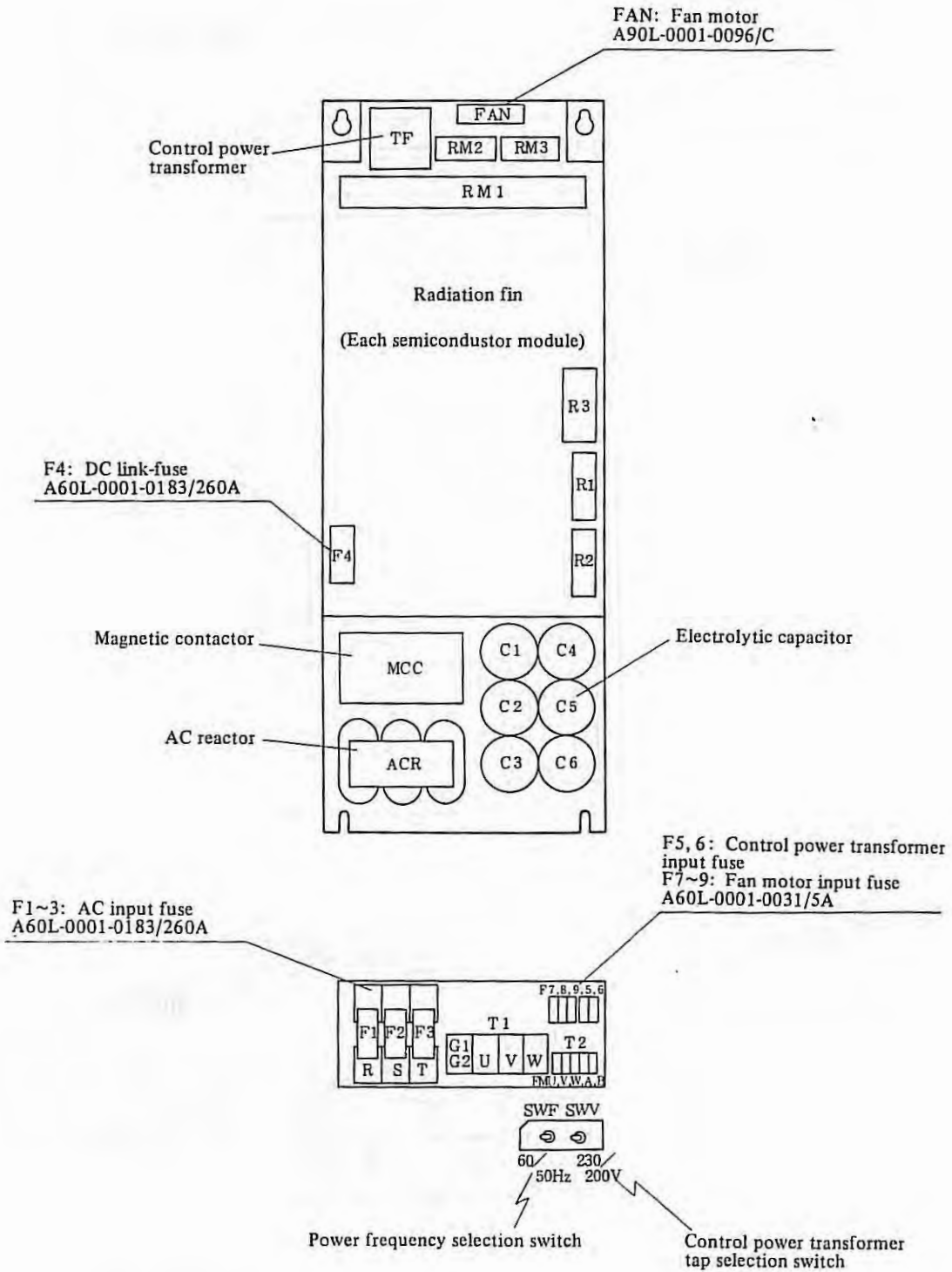

APPENDIX 6 MOUNTING LAYOUT OF SPINDLE CONTROL CIRCUIT PCB

- a) MODEL 1, 2, small MODEL 3
- i) A16B-1100-0080

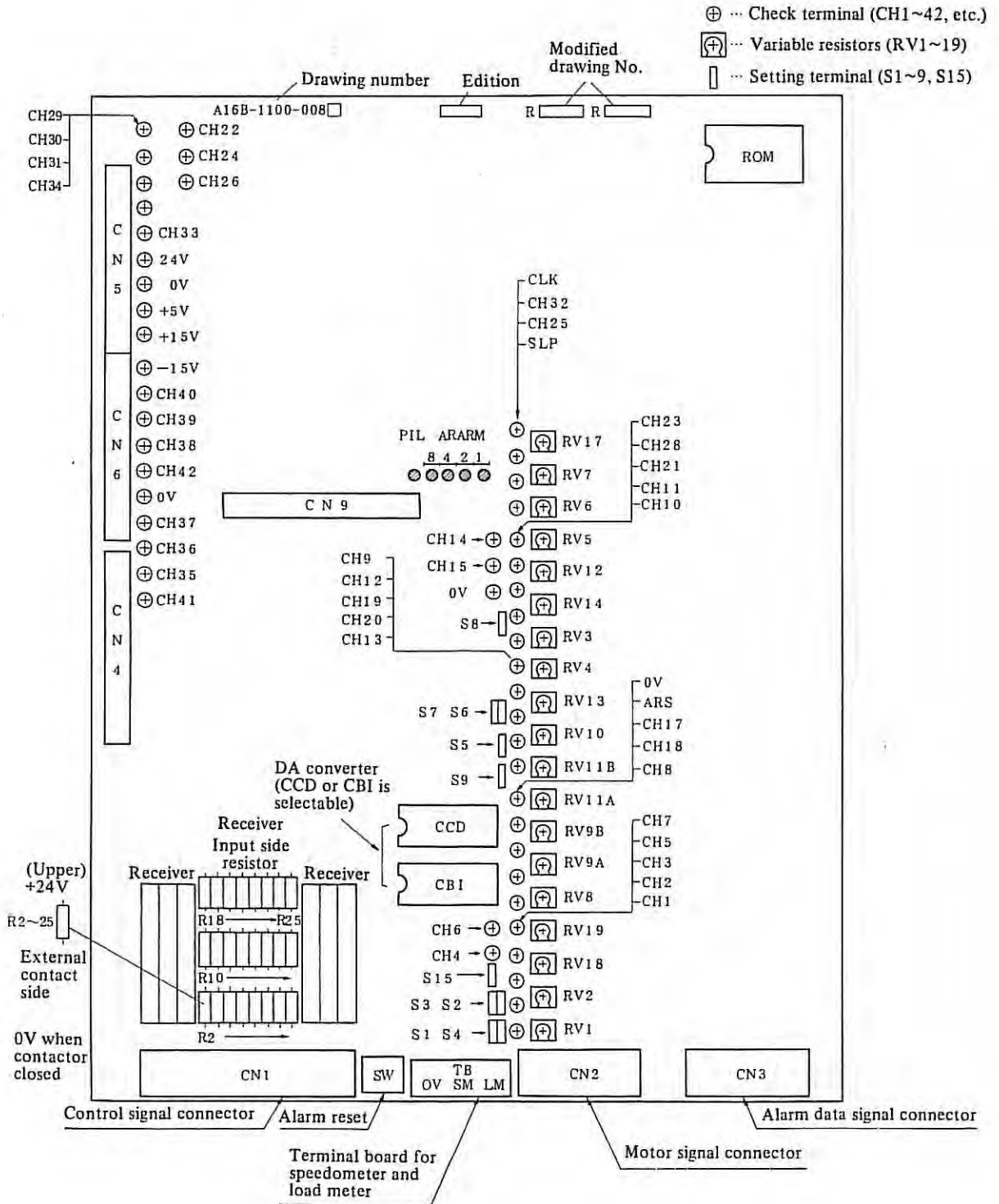

ii) A16B-1100-0090~92

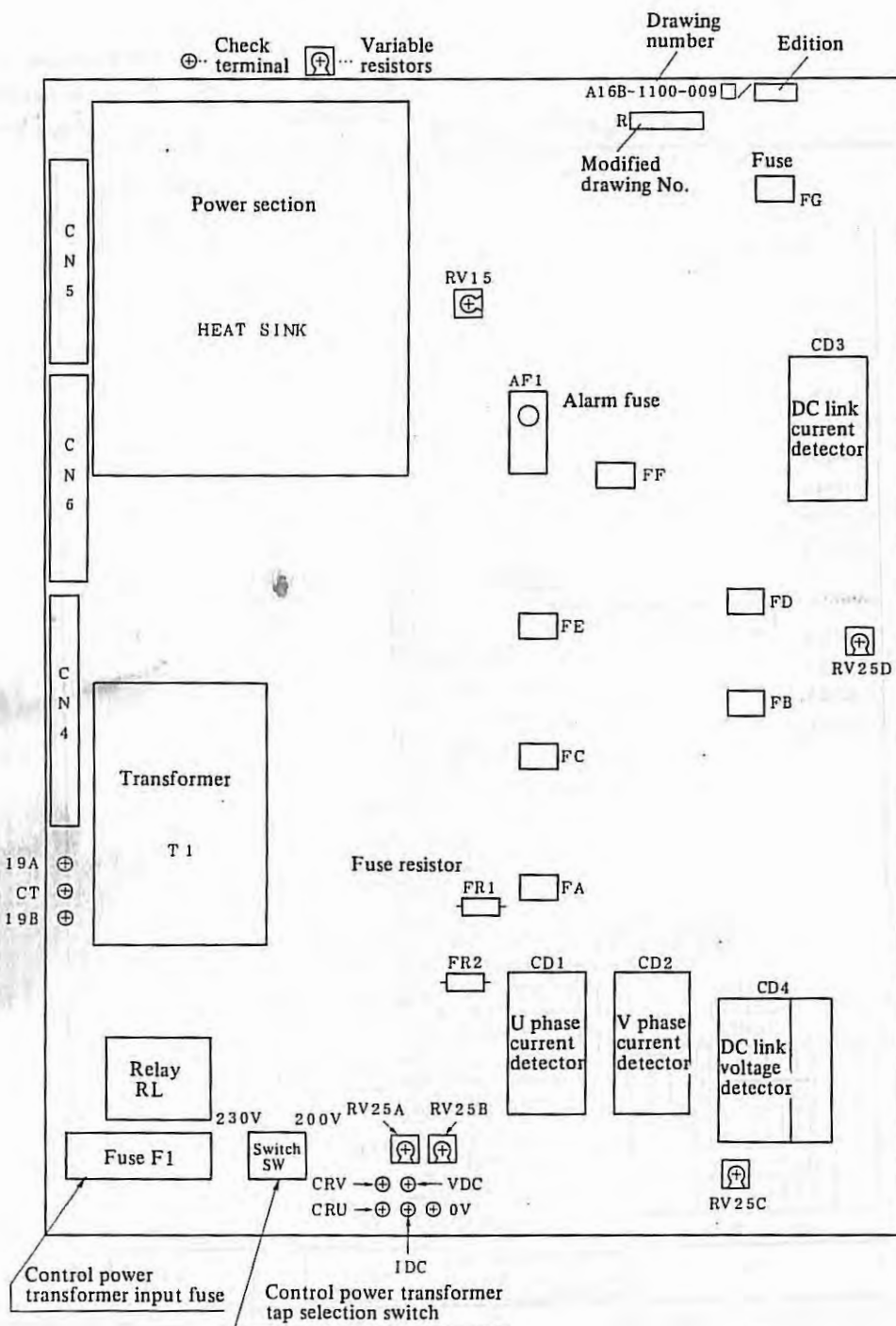

b) MODEL 3~22

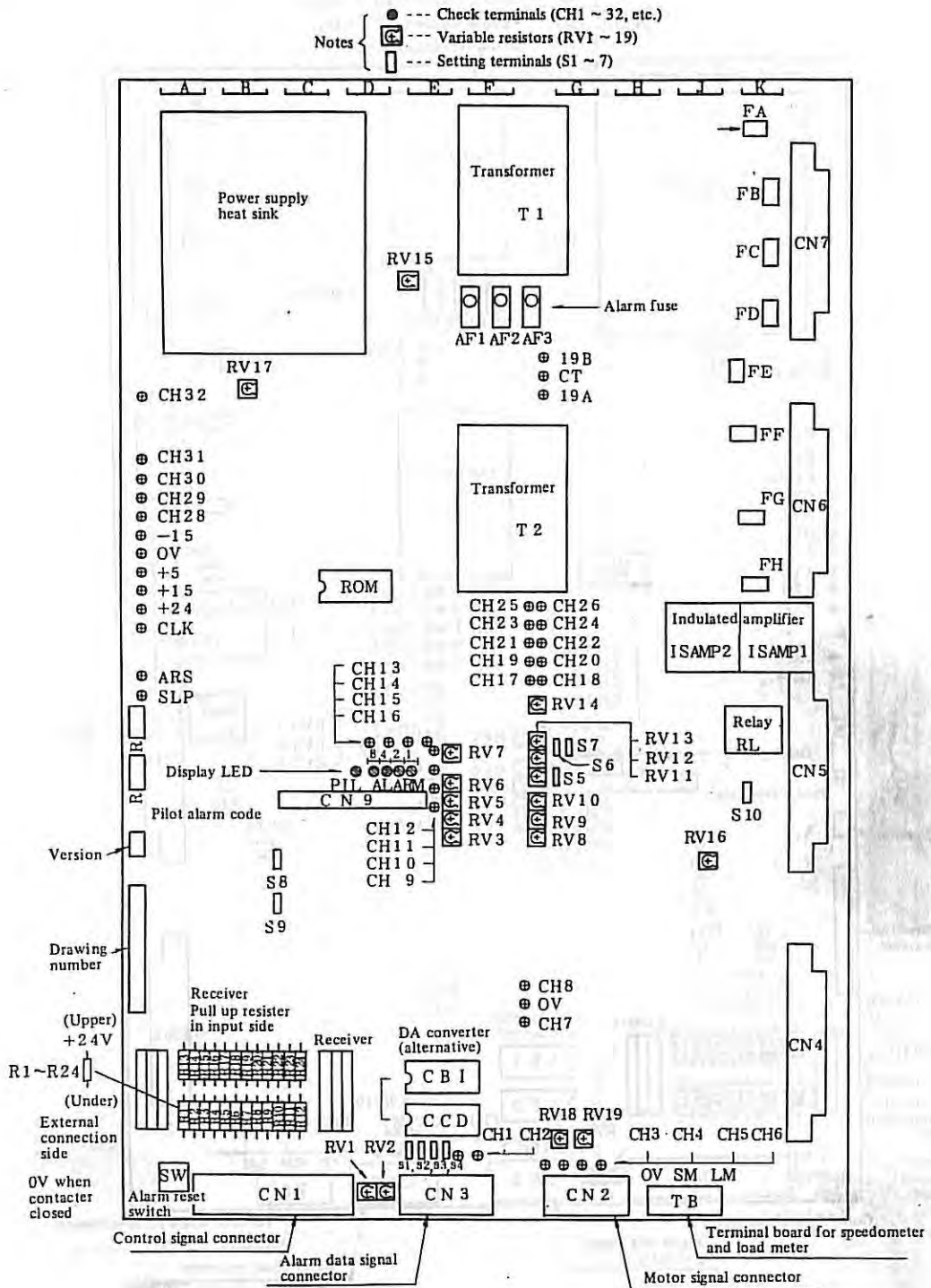

c) MODEL 30, 40

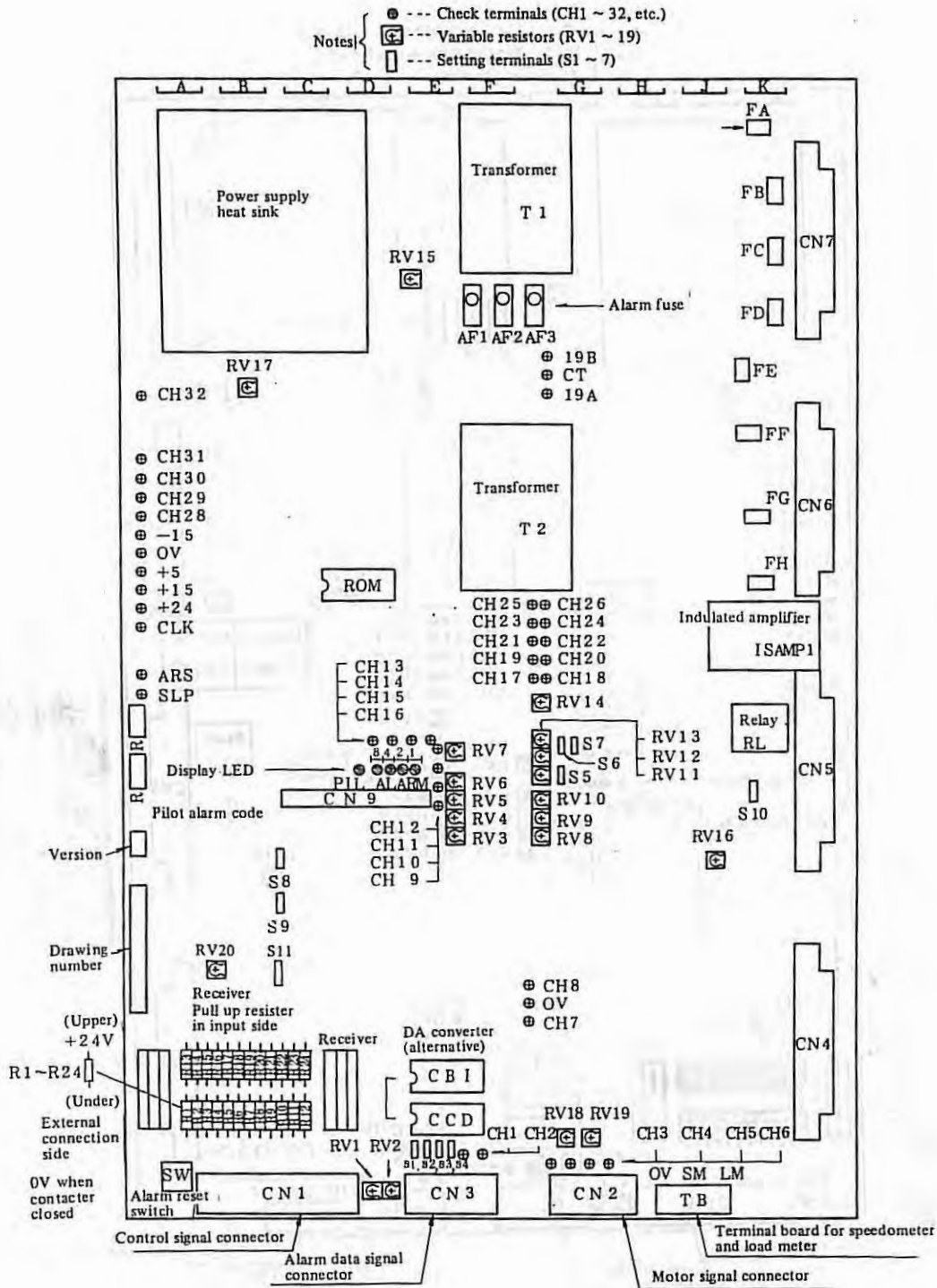

d) AC spindle servo unit (380V/415VAC input type)

A20B-1001-0620

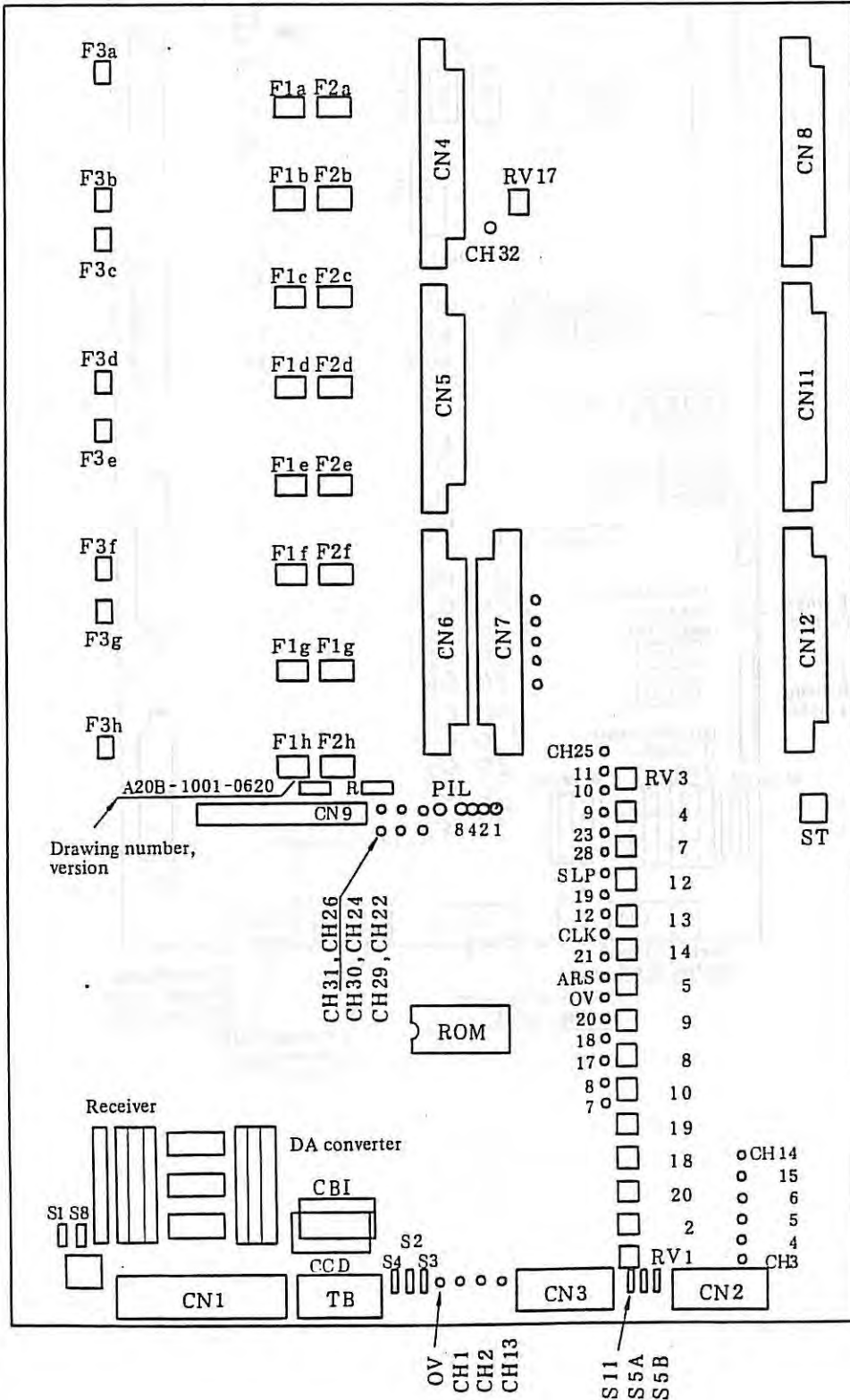

e) Digital AC spindle servo unit (MODEL 3 to 22)

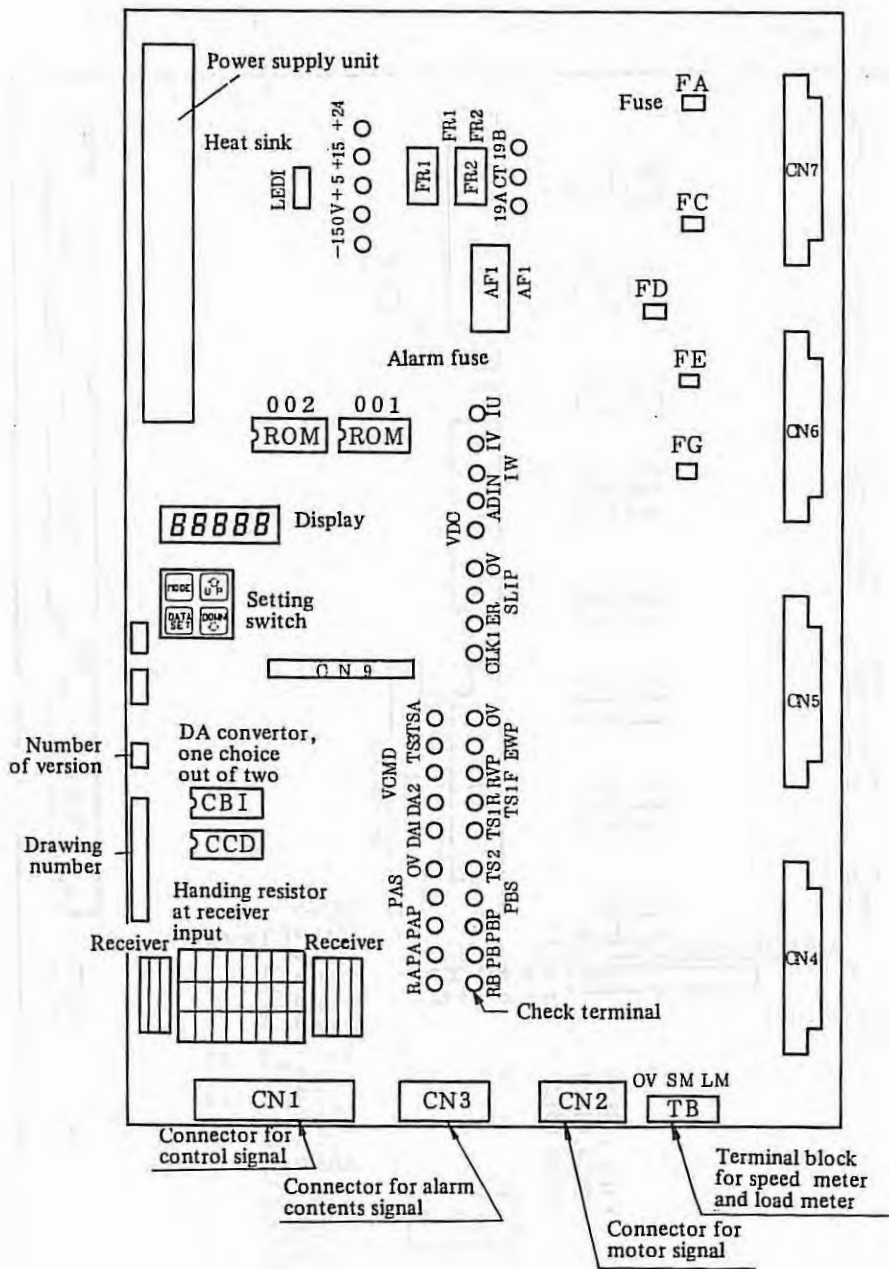

f) Digital AC spindle servo unit (MODEL 1S, 1.5S, 2S, 3S, 2H, 2VH)

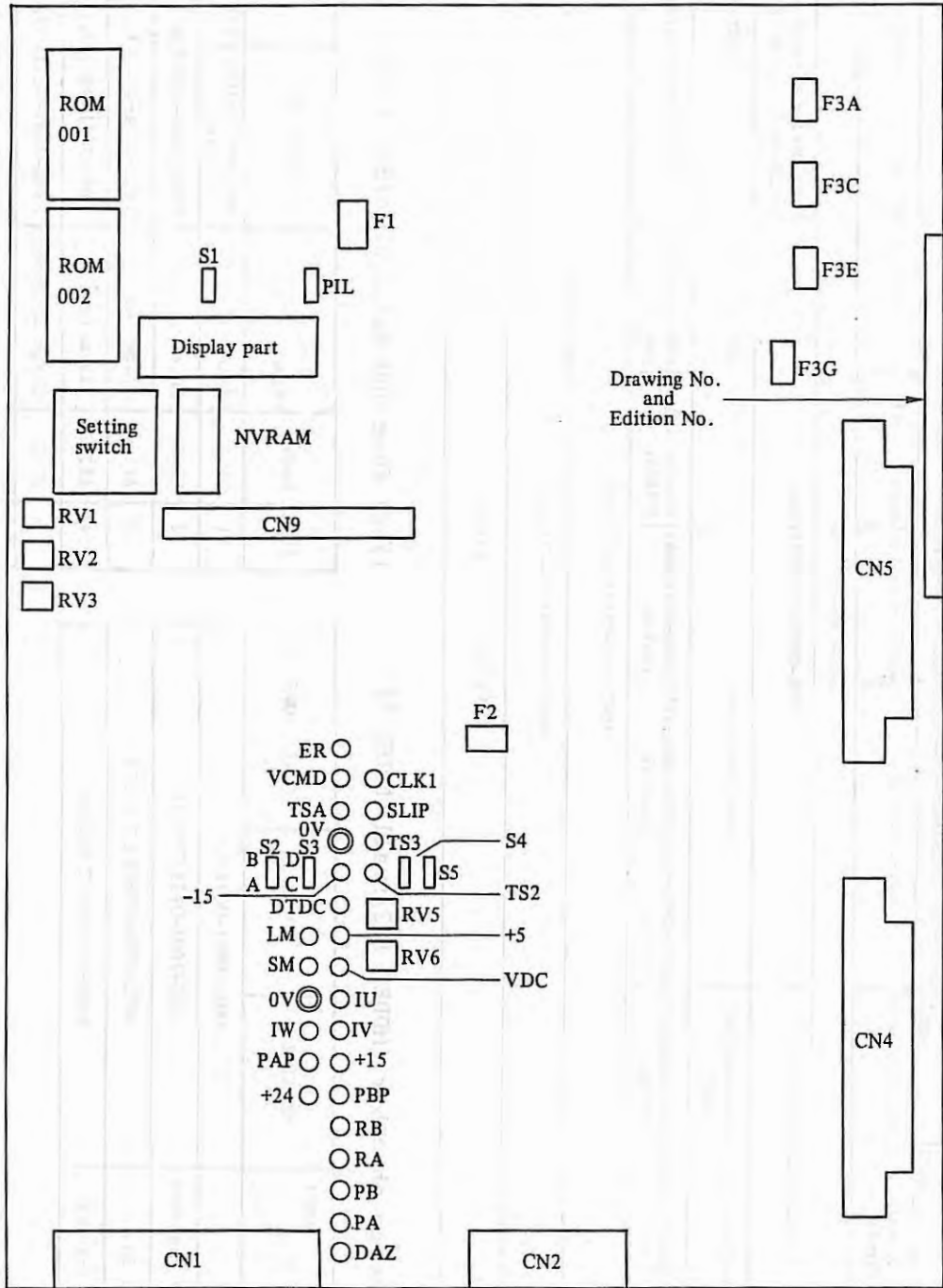

Drawing No. and Edition No.

201-001-0103
 201-001-0103
 201-001-0103

APPENDIX 7 MAJOR PARTS LIST

LVL 32-0

A50L-0001-0109

1)-a) Fuse and surge absorber (MODEL 3~22)

Item	Symbol	MODEL Name	MODEL 3/6		MODEL 8		MODEL 12		MODEL 15	MODEL 18	MODEL 22
			A06B-6044-H007 H008	A06B-6044-H103 H106	A06B-6044-H009	A06B-6044-H108	A06B-6044-H010	A06B-6044-H112			
1	F1~3	Fuse	A60L-0001-0127 /25FH75	A60L-0001-0147	A60L-0001-0145		A60L-0001-0149	A60L-0001-0145	A60L-0001-0149		A60L-0001-0163
2	F4a,b	Fuse	A60L-0001-0131/5A								
3	F5,6	Fuse	A60L-0001-0197/PC1F-20		A60L-0001-0197/PC1F-30				A60L-0001-0197 /PC2F-40	A60L-0001-0197 /PC2F-50	
4	F7	Fuse	A60L-0001-0147	A60L-0001-0127 /25FH75	A60L-0001-0145			A60L-0001-0149		A60L-0001-0163	
5	Z1~4	Surge absorber	A50L-2001-0062 /441-12	A50L-2001-0155 /20D431	A50L-2001-0062 /441-12	A50L-2001-0155 /20D431	A50L-2001-0062 /441-12	A50L-2001-0155 /20D431	A50L-2001-0062 /441-12	A50L-2001-0155/20D431	
6	AF1	Alarm fuse	A60L-0001-0046/3.2 (3.2A)								
7	AF2,3	Alarm fuse	A60L-0001-0075/3.2 (3.2AS)								
8	Fa-h	Fuse for PCB	A60L-0001-0175 (0.3A)								

1)-b) Fuse and surge absorber (MODEL 1/2/small MODEL 3)

Item	Symbol	MODEL Name	MODEL 1	MODEL 2	Small MODEL 3
1	F1	Fuse	A60L-0001-0031/5A		
2	Z1	Surge absorber	A50L-2001-0155/20D431		
3	AF1	Alarm fuse	A60L-0001-0046/3.2 (3.2A)		
4	Fa-g	Fuse for PCB	A60L-0001-0175 (0.3A)		

1)-c) Fuse and surge absorber (MODEL 30/40)

Item	Symbol	MODEL Name	MODEL 30	MODEL 40
1	F1~4	Fuse	A60L-0001-0183 /225A	A60L-0001-0183 /260A
2	F5~9	Fuse	A60L-0001-0031/5A	
3	AF1	Alarm fuse	A60L-0001-0046/3.2 (3.2A)	
4	AF2,3	Alarm fuse	A60L-0001-0075/3.2 (3.2AS)	
5	Z1~3	Surge absorber	A50L-2001-0155/20D431	
6	Z4	Surge absorber	A50L-2001-0162/441-12	
7	Fa-h	Fuse on PCB	A60L-0001-0175 (0.3A)	

- 158 -

2)-a) Main parts (MODEL 3v22)

Item	Symbol (Note)	MODEL Name	MODEL 3	MODEL 6	MODEL 8	MODEL 12	MODEL 15	MODEL 18	MODEL 22
1	P.C.B.	PCB	A20B-0009-0530 A20B-1000-0690	A20B-0009-0531 A20B-1000-0691	A20B-0009-0532 A20B-1000-0692	A20B-0009-0533 A20B-1000-0693	A20B-0009-0534	A20B-0009-0538	A20B-0009-0539
2	ROM	Memory element	J10	J11	J02	J03	J04	J05	J06
3	TM (1-12)	Transistor module	A50L-0001-0096/A		A50L-0001-0109		A50L-0001-0096 /A	A50L-0001-0109	
4	SM (1-3)	Thyristor module	A50L-5000-0029/30		A50L-5000-0029/50			A50L-5000-0029/80	
5	DM (1-3)	Diode module	A50L-2001-0138		A50L-2001-0168	A50L-2001-0146			
6	D (1-3)	Diode	A50L-2001-0103/12JH11						
7	D (4-6)	Diode	A50L-2001-0103/12JG11						
8	D (7,8)	Diode	A50L-2001-0097/U06G						
9	C (1-3)	Capacitor	A42L-0001-0103						
10	MCC	Magnetic contactor	A58L-0001-0094/200V1A1B		A58L-0001-0092/A		A58L-0001-0146	A58L-0001-0165	A58L-0001-0166
11	TF	Transformer	A80L-0001-0276						
12	FAN	Fan motor	A90L-0001-0191	A90L-0001-0099/A					
13	TH	Thermostat	A57L-0001-0051 /B100	A57L-0001-0051 /B90	A57L-0001-0051 /B100 A57L-0001-0052 /B150	A57L-0001-0051 /B95 A57L-0001-0052 /B150	A57L-0001-0028	A57L-0001-0046/90 A57L-0001-0046/150	
14	ACR	AC reactor	A81L-0001-0077		A81L-0001-0076	A81L-0001-0075	A81L-0001-0080	A81L-0001-0063	
15	SW	Toggle switch	A57L-0001-0048/A				A56L-0001-0030 /2A	A50L-0001-0048	

Note) Parts number in parenthesis are different depends on unit model.
Refer to the parts mounting label in the unit for the details.

2)-b) Main parts (MODEL 1/2/small MODEL 3)

Item	Symbol	MODEL			
		Name	MODEL 1	MODEL 2	Small MODEL 3
1	P.C.B.	PCB I		A16B-1100-0080	
2	P.C.B.	PCB II	A16B-1100-0090	A16B-1100-0091	A16B-1100-0092
3	ROM	Memory element	J21	J22	J23
4	TM1	Transistor module		A50L-0001-0125	
5	TR1	Transistor		A50L-0001-0126	
6	DM1	Diode module		A50L-2001-0138	
7	C1	Capacitor		A42L-0001-0142	
8	MCC	Magnetic contactor		A58L-0001-0207	
9	TF	Transformer		A80L-0001-0486	
10	ACR	AC reactor		A81L-0001-0083/3	

2)-c) Main parts (MODEL 30, 40)

Item	Symbol	MODEL		
		Name	MODEL 30	MODEL 40
1	P.C.B	PCB	A20B-1000-0700	A20B-1000-0701
2	ROM	Memory element	J07	J08
3	TM (1-22)	Transistor module	A50L-0001-0116	
4	SM (1-3)	Thyristor module	A50L-5000-0033	
5	DM (1-3)	Diode module	A50L-2001-0171	
6	D (1-16)	Diode	A50L-2001-0103/12JH11	
7	D (3-15)	Diode	A50L-2001-0103/12JG11	
8	MCC	Magnetic contactor	A58L-0001-0133 /200V	A58L-0001-0159 /200V
9	TF	Transformer	A80L-0001-0276	
10	FAN	Fan motor	A90L-0001-0096/C	
11	TH	Thermostat	A57L-0001-0028	
12	ACR	AC reactor	A81L-0001-0078	A81L-0001-0079
13	SW	Toggle switch	A57L-0001-0048/A	

APPENDIX 8 PCB ADJUSTMENTS

1) MODEL 3 to 22

The following table shows the adjustment of PCB in each AC spindle servo unit. Don't change RV 7, 8, 19, 25A~D variable resistors, since these parts have already been adjusted by FANUC at the time of delivery.

No.	Symbol	Adjustment items	Standard setting	Measuring terminals	Adjusting methods
1	RV1	Velocity command voltage level		CH13-0V	See subsection 1).
2	RV2	Velocity command voltage offset		CH13-0V	See subsection 1).
3	RV3	Speed arrival detection level		CH10-0V	See subsection 4).
4	RV4	Speed detection level		CH9-0V	See subsection 5).
5	RV5	Torque limitation level			See subsection 6).
6	RV6	Regenerative power limitation	3 divisions		
7	RV7	VF conversion level (1)		CH23-0V	200 \pm 2 kHz when voltage is 10 V between LM and OM.
8	RV8	Speed detection circuit setting		CH18-0V	1.38 \pm 0.03 V at forward rotation of motor in 45 rpm.
9	RV9	Forward motor speed adjustment		Number of motor revolutions	See subsection 2).
10	RV10	Speed detection offset		CH17-0V	Lower than \pm 2 V when the spindle stops.
11	RV11	Reverse motion speed adjustment		Number of motor revolutions	See subsection 2).
12	RV12	Velocity loop gain	3 divisions		
13	RV13	Velocity loop offset		Number of spindle revolutions	See subsection 3).

MODEL 1/2/small MODEL 3 ... A16B-1100-0080, A16B-1100-0090~0092
 MODEL 3~12 ... A20B-1000-0690~0693, A20B-0009-0530 ~ 0533
 MODEL 15~22 ... A20B-0009-0534~0539
 MODEL 30, 40 ... A20B-1000-0700, 0701

No.	Symbol	Adjustment items	Standard setting	Measuring terminals	Adjusting methods
14	RV14	Load meter amplitude adjustment		LM-0M	10 + 0.1 V at acceleration
15	RV15	+5 V voltage adjustment		+5V-0V	5 <u>+</u> 0.05 V
16	RV16	Regenerative voltage limitation level	4 divisions	/	
17	RV17	VF conversion level (2)		CH32-0V	24.5 kHz at input AC 200 V
18	RV18	RA offset adjustment		CH5-0V	The rate of ON time at CH7 waveform to be 50%.
19	RV19	RB offset adjustment		CH6-0V	The rate of ON time at CH8 waveform to be 50%.
20	RV20	Soft start/stop time constant adjustment	0 divisions	CH13-0V	The time constant can be selected by setting of short pin S11. Short A side of S11 ... 0.6~8 sec. Short B side of S11 ... 3.5~40 sec. Check waveform of acceleration or deceleration at CH13 (VCMD).
21	RV25A-D	Current/voltage detector offset adjustment		CRU, CRV IDC, VDC-0V	0 +2.5 mV when spindle stop

(Note) How to read the variable resistor scale

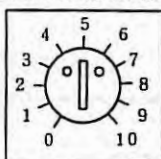

1) Velocity command voltage (RV1, RV2)

When the velocity command voltage is 10 V, the motor rotates at the rated speed.

Item	Measuring terminal	Adjusting procedure
Offset	CH13-0V	Give velocity command voltage 0 V (equivalent to S00) after setting the motor to be ready for operation. Adjust RV2 while alternately giving the forward rotation and reverse rotation commands, until the voltage remains unchanged at measuring terminal. (Note)
Level	CH13-0V	Give the rated rotation command 10 V to the motor, and adjust RV1 until the measuring terminal voltage becomes +10 V \pm 0.05 V when the spindle forward rotation command is sent.

Note) If the voltage at CH13 is +5.0 mV when the spindle rotates forward and +5.0 mV \pm 1.0 mV when the spindle rotates reversely, the offset error becomes \pm 1.0 mV when the velocity command voltage directions are inverted.

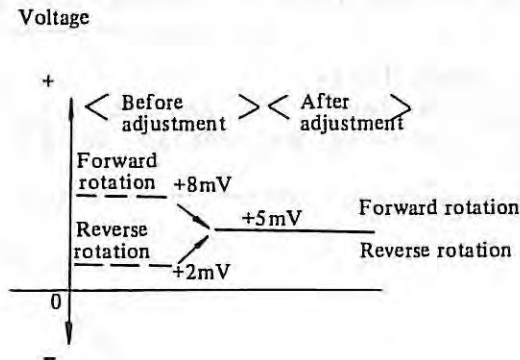

2) Rotation speed adjustment (RV9, RV11)

The number of spindle revolutions can be finely adjusted according to the following procedure.

Measure the number of spindle revolutions directly by using a stroboscope or a tachometer.

Item	Measuring terminal	Adjusting procedure
Number of forward revolutions	Spindle	Give the specified motor rotation command voltage. Adjust RV9 so that the motor rotates at the specified speed when the forward rotation (SFR) command is given.
Number of reverse revolutions	Spindle	Adjust RV11 so that the motor rotates at the specified speed when the reverse rotation (SRV) command is given.

Note 1) In MODEL 1/2/small MODEL 3, adjust RV9A, 9B during forward rotation or RV11A, 11B during reverse rotation according to the above procedure.

Note 2) The forward rotation means that the AC spindle motor rotates counter-clockwise as viewed from the motor shaft direction and this forward rotation (SFR) does not always correspond to the forward rotation of the machine tool spindle.

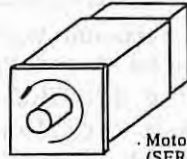

Motor forward rotation (SFR) direction

3) Velocity offset (RV13)

Adjust RV13 after completion of the previous adjustments so that the spindle does not rotate at low speed when the velocity command voltage 0 V is given.

Item	Measuring terminal	Adjusting procedure
Velocity offset	Spindle (or motor)	Adjust RV13 so that the spindle does not rotate when the velocity command voltage 0 V and either forward or reverse rotation command are given.

4) Speed arrival detection level (RV3)

The speed arrival detection level can be set according to the following graph. The coordinate indicates percentage to the rated revolutions of motor.

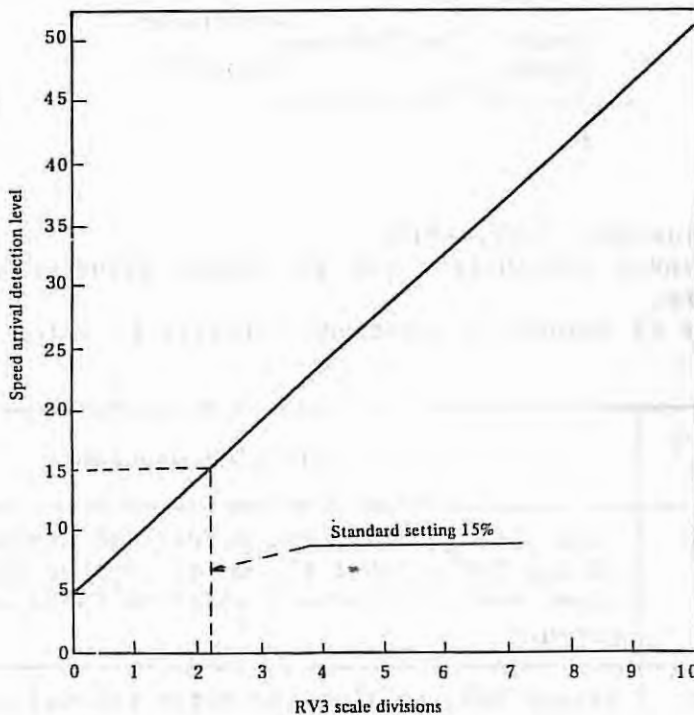

Note) Now to read the variable resistor scale divisions.

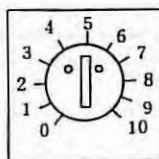

5) Speed detection level (RV4)

The coordinate indicates percentage to the rated revolutions of the motor. This signal is used as a check signal when the clutch or gear is changed.

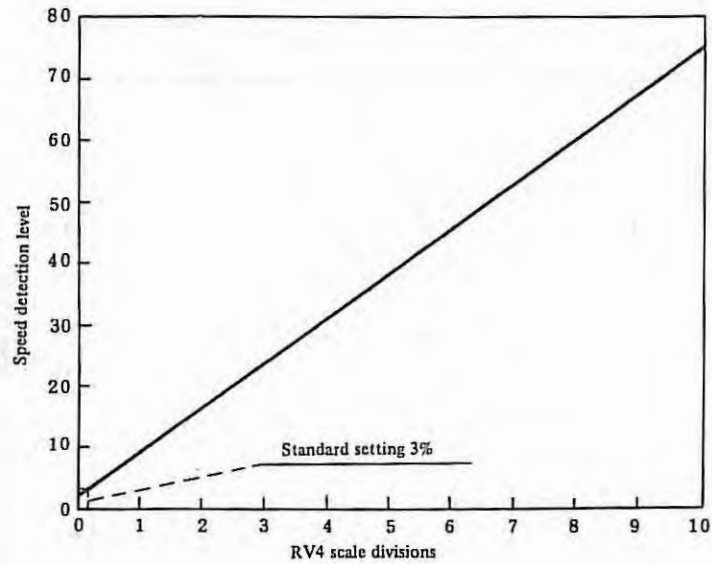

6) Torque limitation level (RV5)

The coordinate indicates percentage to the 30-minute rated torque.

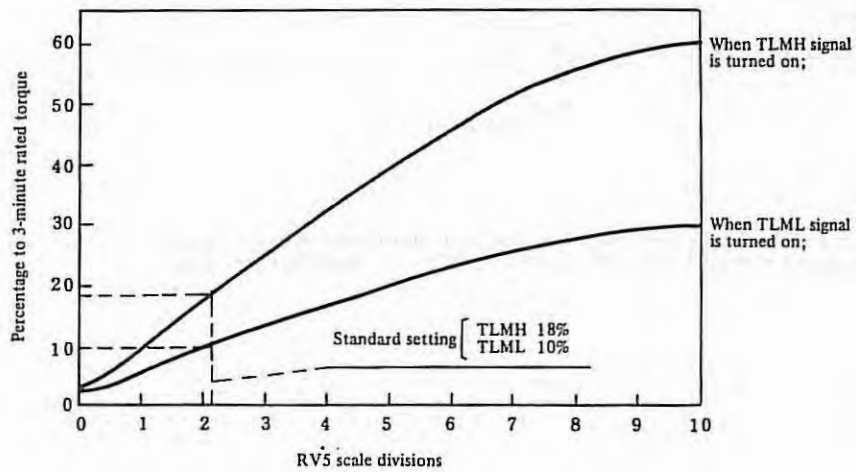

7) Soft start/stop time constant

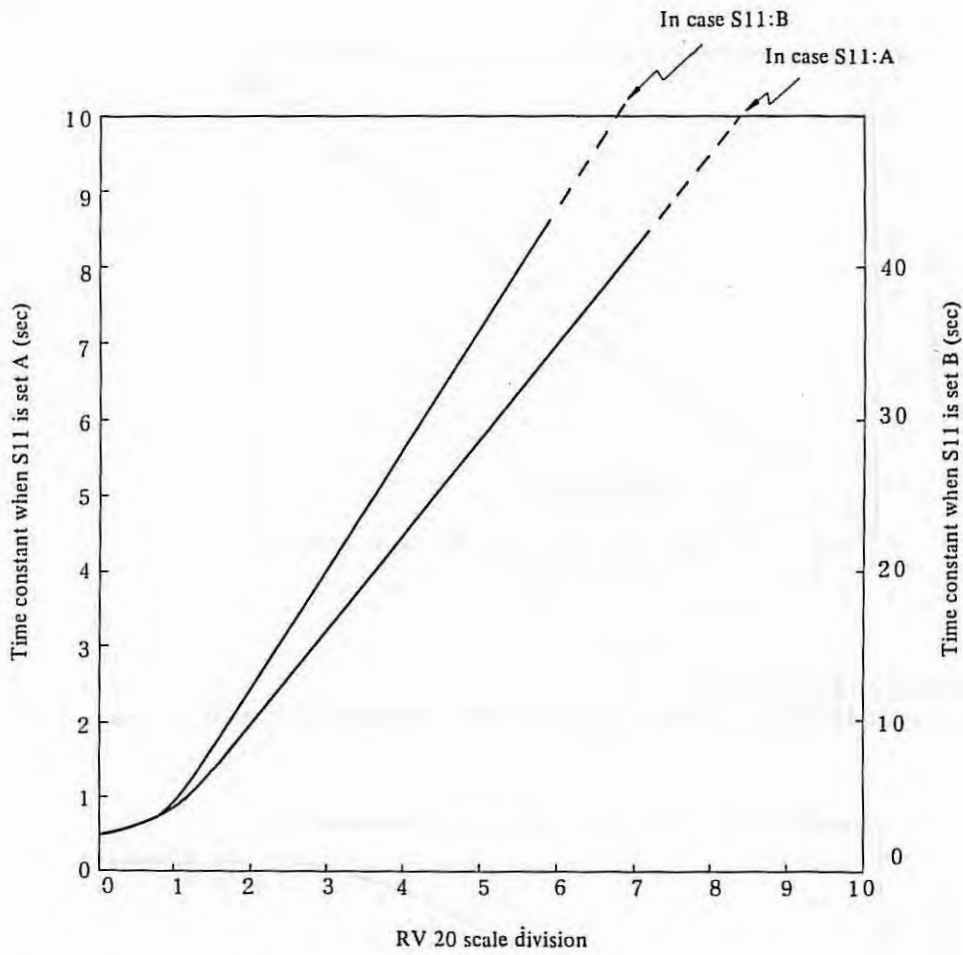

Note) Soft start/stop time constant shows rising and falling time when set velocity command voltage (VCMD) 0V to 10V or 10V to 0V. Refer to next figure.

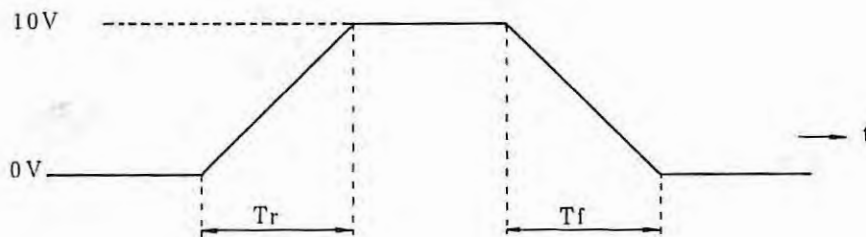

$T_r = T_f$. Soft start/stop time constant

2) PCB for 380/415 VAC input type

POT name	Object of adjustment	Standard scale	Observation terminals	Adjustment standard
RV1	Voltage command voltage level	5.0	CH13	10 V ± 0.02 V at the rated velocity command of SFR
RV2	Voltage command voltage offset	5.0	CH13	Voltage difference = ± 1 mV at zero velocity command of SFR and SRV
RV3	Speed arrival detection level	1.5 V 3.0	CH10	Variable from 0.5 to 5.0 V at rated velocity of SFR and SRV
RV4	Speed detection level	0.3 V 1.0	CH9	Variable from 0.15 to 6.7 V
RV5	Torque limiting value		Output torque	A specified torque L \rightarrow 5 \sim 25% of max torque, H \rightarrow 10 \sim 50%
RV7	ER VF conversion ratio	7.0	CH23	200 kHz ± 2 kHz PPS for 10.0 V between LM-OM
RV8	Low velocity detection level		CH18	-1.38V ± 0.03 V at velocity command of 45 rpm for CH17
RV9	Velocity detection level		Motor speed	Is rpm of rated velocity at rated velocity command of SFR
RV10	Velocity detection offset		CH17	± 5 mV when spindle stops
RV12	Velocity loop gain	5.0	Motor rotation	Be sure not to have overshoot and hunting at high speed
RV13	Velocity offset		Motor rotation	Be sure not to rotate at zero command of SFR
RV14	Calibration of max. amplitude		LM-OM	10 V ± 0.1 V at deceleration at acceleration (no torque limit)
RV17	VF conversion ratio of input voltage	7.0	CH32	38 k ± 0.6 kpps at 380 VAC of input voltage
RV18	RA offset compensation	5.0	CH5	Specifies CN7/CH8 duty to 50% with CN2
RV19	RB offset compensation	5.0	CH6	Ditto
RV20	Ramp time of velocity command	0.0	CH13	Variable from 0.6 to 8 sec at S11=A or from 3.5 to 40 sec at S11=B when V.command is 10 V

APPENDIX 9 CHECKING METHOD FOR PCB

1. CHECK TERMINAL

For the mounting positions of check terminals, see mounting layout of parts in PCB in Appendix 6.

- a) MODEL 3~12 ... A20B-1000-0690~0693
 MODEL 15~22 ... A20B-0009-0530~0593
 MODEL 30, 40 ... A20B-1000-0700, 0701

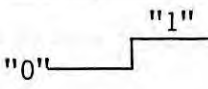
Name of terminal	Name of signal	Signal data	Remarks
CH1	DA2	Analog command voltage	0 - 10.0V
CH2	DA1	D/A converter output voltage	0 - 10.0V
CH3	PA	Pulse generator output A-phase	
CH4	PB	Pulse generator output B-phase	PA leads PB by 90° in CW rotation
CH5	RA	A-phase reference voltage	PA DC <u>+25mV</u>
CH6	RB	B-phase reference voltage	PB DC <u>+25mV</u>
CH7	PSA	A-phase square wave	Duty 50% (at constant speed) <u>+10%</u>
CH8	PSB	B-phase square wave	Duty 50% (at constant speed) <u>+10%</u> PSA leads PSB by 90° in CW rotation
CH9	SDTRF	Speed detection level	Variable over a range of 0.14 - 7.4V by RV4
CH10	SARRF	Speed arrival level	Variable over a range of 0.5 - 5.0V by RV3
CH11	BUZY	Acceleration/ deceleration in progress	 "1" level during acc./dcc.
CH13	VCMD	Velocity command voltage	0 - <u>+10.0V</u> ⊕ ; CCW, ⊖ ; CW
CH14	RVP	Reverse rotation speed level	Pulse width 3.2 s generated during reverse rotation only
CH15	FWP	Forward rotation speed level	Pulse width 3.2 s generated during forward rotation only
CH16	OV	PCB OV	

Name of terminal	Name of signal	Signal data	Remarks																																
CH17	TS1	Velocity feedback F/V output	-8V at 6000 rpm in CCW (forward) rotation																																
CH18	TS2	Low speed detection signal	-1.38 \pm 0.03V at 45 rpm in CCW (forward) rotation																																
CH20	TSA	Velocity feedback signal	+10V at rated rotation speed and (-) in CCW rotation.																																
CH21	LTRF	Output torque limitation voltage	Output = $-(C V_{CH21} + 1.8)/10$ x maximum output																																
CH22	CRU	U-phase current detection signal	<table border="1"> <thead> <tr> <th colspan="8">Current/V</th> </tr> <tr> <th>M3.6</th> <th>M8</th> <th>M12</th> <th>M15</th> <th>M18</th> <th>M22</th> <th>M30</th> <th>M40</th> </tr> </thead> <tbody> <tr> <td>16.7</td> <td>25A</td> <td>35.7</td> <td>50A</td> <td>50A</td> <td>62.5</td> <td>52.1</td> <td>104.2</td> </tr> <tr> <td>A</td> <td></td> <td>A</td> <td></td> <td></td> <td>A</td> <td>A</td> <td>A</td> </tr> </tbody> </table>	Current/V								M3.6	M8	M12	M15	M18	M22	M30	M40	16.7	25A	35.7	50A	50A	62.5	52.1	104.2	A		A			A	A	A
Current/V																																			
M3.6	M8	M12	M15	M18	M22	M30	M40																												
16.7	25A	35.7	50A	50A	62.5	52.1	104.2																												
A		A			A	A	A																												
CH23	ERP	VF conversion output	200 kHz when $L_M - 0V$ is 10V, 0.4 μ s width																																
CH24	CRV	V-phase current detection signal	See CH22																																
CH25	TRWF	Triangular wave signal	 10Vp-p																																
CH26	CRW	W-phase current detection signal	See CH22																																
CLK	CLK	Clock signal	312.5 kHz, 200 ns typ.																																
+24	24V	+24V power voltage																																	
+15	15V	+15V power voltage																																	
+5	5V	+5V power voltage	+5V \pm 1% (already adjusted by RV15)																																
0V	0V	PCB 0V	Same as the 0V and CH16																																
-15	-15V	-15V power voltage	-15V \pm 4%																																
CH28	ER	Error voltage	0 - 10V																																
CH29	UCM	U-phase command voltage																																	
CH30	VCM	V-phase command voltage																																	
CH31	WCM	W-phase command voltage																																	
CH32	24VP	24V VFC output																																	
19A	19A	AC 19V input voltage	For PCB control power supply																																

Name of terminal	Name of signal	Signal data	Remarks
CT	CT	0V	For PCB control power supply
19B	19B	AC 19V input voltage	For PCB control power supply
SLP	SLP	Slip frequency	Pulse width: 3.2 μ s

b) MODEL 1/2/small MODEL 3

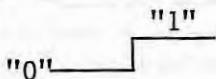
Name of terminal	Name of signal	Signal data	Remarks
CH1	DA2	Analog command voltage	0 - 10.0V
CH2	DA1	D/A converter output voltage	0 - 10.0V
CH3	PA	Pulse generator output A-phase	
CH4	PB	Pulse generator output B-phase	PA leads PB by 90° in CW rotation
CH5	RA	A-phase reference voltage	PA DC <u>+25mV</u>
CH6	RB	B-phase reference voltage	PB DC <u>+25mV</u>
CH7	PSA	A-phase square wave	Duty 50% (at constant speed) <u>+10%</u>
CH8	PSB	B-phase square wave	Duty 50% (at constant speed) <u>+10%</u> PSA leads PSB by 90° in CW rotation
CH9	SDTRF	Speed detection level	Variable over a range of 0.14 - 7.4V by RV4
CH10	SARRF	Speed arrival level	Variable over a range of 0.5 - 5.0V by RV 3
CH11	BUZY	Acceleration/ deceleration in progress	 <p>"1" level during acc./dcc.</p>
CH13	VCMD	Velocity command voltage	0 - <u>+10.0V</u> ⊕ ; CCW, ⊖ ; CW
CH14	RVP	Reverse rotation speed level	Pulse width 3.2 s generated during reverse rotation only
CH15	FWP	Forward rotation speed level	Pulse width 3.2 s generated during forward rotation only

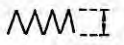
Name of terminal	Name of signal	Signal data	Remarks						
CH17	TS1	Velocity feedback F/V output	-8V at 6000 rpm in CCW (forward) rotation						
CH18	TS2	Low speed detection signal	-1.38 +0.03V at 45 rpm in CCW (forward) rotation						
CH20	TSA	Velocity feedback signal	+10V at rated rotation speed and (-) in CCW rotation.						
CH21	LTRF	Output torque limitation voltage	Output = $-(C V_{CH21} + 1.8)/10$ x maximum output						
CH22	CRU	U-phase current detection signal	Current/1V <table border="1"> <thead> <tr> <th>M1</th> <th>M2</th> <th>M3</th> </tr> </thead> <tbody> <tr> <td>6.43A</td> <td>12.86A</td> <td>12.86A</td> </tr> </tbody> </table>	M1	M2	M3	6.43A	12.86A	12.86A
M1	M2	M3							
6.43A	12.86A	12.86A							
CH23	ERP	VF conversion output	200 kHz when $L_M - 0V$ is 10V, 0.4 μ s width						
CH24	CRV	V-phase current detection signal	See CH22						
CH25	TRWF	Triangular wave signal	 10Vp-p						
CH26	CRW	W-phase current detection signal	See CH22						
CLK	CLK	Clock signal	312.5 kHz, 200 ns typ.						
+24	24V	+24V power voltage							
+15	15V	+15V power voltage							
+5	5V	+5V power voltage	+5V +1% (already adjusted by RV15)						
0V	0V	PCB 0V	Same as the 0V and CH16						
-15	-15V	-15V power voltage	-15V +4%						
CH28	ER	Error voltage	0 - 10V						
CH29	UCM	U-phase command voltage							
CH30	VCM	V-phase command voltage							
CH31	WCM	W-phase command voltage							
CH32	24VP	24V VFC output							
19A	19A	AC 19V input voltage	For PCB control power supply						
CT	CT	0V	For PCB control power supply						

Name of terminal	Name of signal	Signal data	Remarks
19B	19B	AC 19V input voltage	For PCB control power supply
SLP	SLP	Slip frequency	Pulse width: 3.2 μ s
CH33	VDCA	DC link voltage detection signal	95V/1V
CH34	IDCA	DI link current detection signal	10.6A/1V (model 2/3), 5.3A/1V (model 1)
CH35	*INA	A-phase driver control signal	
CH36	*INB	B-phase driver control signal	
CH37	*INC	C-phase driver control signal	
CH38	*IND	D-phase driver control signal	
CH39	*INE	E-phase driver control signal	
CH40	*INF	F-phase driver control signal	
CH41	*REG	Regenerative circuit driver control signal	
CH42	*LMT	Overcurrent/overvoltage limit	Driver circuit is turned off at 56.25A or 420V.
CRU	CRU	U-phase current detection	0.54V <u>+7%</u> at 50A
CRV	CRV	V-phase current detection	0.54V <u>+7%</u> at 50A
IDC	IDC	DC link current detection signal	
VDC	VDC	DC link voltage	

c) 380 V/415 VAC input type

Name of terminal	Name of signal	Signal data	Remarks
CH1	DA2	Velocity command voltage input	Is 0 - 10 V when external velocity command is given.
CH2	DA1	DA conversion output voltage	Is changeable by convertor input bit command of 0 - 10 V.
CH3	PA	Pulse generator A-phase	Advances 90° against PB by CW rotation for $V_{p-p} = 0.36 - 0.5$ V. ($5 \text{ V}/2 \pm 5\%$) $\pm 0.2 \text{ V}_{typ}$.
CH4	PB	Pulse generator B-phase	Delays 90° against PA by CW rotation for $V_{p-p} = 0.36 - 0.5$ V. ($5 \text{ V}/2 \pm 5\%$) $\pm 0.2 \text{ V}_{typ}$.
CH5	RA	A-phase reference voltage	DC part of PA. (2.5 V ± 0.25 V)
CH6	RB	B-phase reference voltage	DC part of PB. (2.5 V ± 0.25 V)
CH7	PSA	A-phase rectangular wave	Pulse width duty 1/2, 256 pulses/1 motor rotation.
CH8	PSB	B-phase rectangular wave	Pulse width duty 1/2, 256 pulses/1 motor rotation.
CH9	SDTRF	Velocity detection reference voltage	Is variable in the range of 0.14 - 7.4 V/RV4. Standard setting is 0.3 V.
CH10	SARRF	Velocity arrival reference voltage	Is variable in the range of 0.5 - 5.0 V/RV3 for velocity command of 10 V. (Standard: 1.5 V)
CH11	BUZY	Adjustable velocity signal	45 sec typ. level "1" from the step change of more than 1.4 V of velocity command.
CH12	TEST	C-short terminal for integration	Is short-circuited at both ends of condenser C68 when connected to (0 V) terminal.
CH13	VCMD	Velocity command voltage	For positive, motor is forward (CCW) and for negative, reverse (CW). Rated velocity command is ± 10 V.
CH14	RVP	Reverse velocity pulse	Occurs at reverse (CW) with pulse width 3.2 μs and 1024 pulses/1 motor rotation.

Name of terminal	Name of signal	Signal data	Remarks				
CH15	FWP	Forward velocity pulse	Occurs at forward (CCW) with pulse width 3.2 μ s and 1024 pulses/1 motor rotation.				
CH17	TA1	Velocity FVC output	Is 10 V for forward 6000 rpm.				
CH18	TS2	Low speed detection signal	Is -1.38 \pm 0.03 V for forward 45 rpm.				
CH19	VLER	Velocity deviation compensating signal	Negative voltage for CCW and positive for CW.				
CH20	TSA	Velocity detection signal	\pm 10 V (for CCW) at rated rotation speed.				
CH21	LTRF	Torque limiting reference voltage	Limited output = $[(V_{CH21} + 1.8) / 10] \times \text{max.output}$, (-8.2 V)				
CH22	CRU	U-phase current detection signal	$\text{CURRENT} = V_{CH22} / (6 \times R_{CD}) \text{A}$ <table border="1" style="margin-left: auto; margin-right: auto;"> <tr> <td></td> <td>M40, M30</td> </tr> <tr> <td>R_{CD}</td> <td>3 mΩ</td> </tr> </table>		M40, M30	R_{CD}	3 m Ω
	M40, M30						
R_{CD}	3 m Ω						
CH23	ERP	Error VF conversion output	200 kHz and pulse width \approx 0.4 μ s for CH28 (ER).				
CH24	CRV	V-phase current detection signal	Refer to CH22.				
CH25	TRWF	Triangular wave for PWM reference	1.50025 kHz, 10 V _{pp} typ.				
CH26	CRW	W-phase current detection signal	Refer to CH22.				
CH28	ER	Error (or weakening) voltage	0 - 10 V (max. output at 10 V).				
CH29	IUCMD	U-phase command voltage	Sine-wave				
CH30	IVCMD	V-phase command voltage	Lags 120° against CH29 (UCM) for CCW.				
CH31	IWCMD	W-phase command voltage	Lags 240° against CH29 (UCM) for CCW.				
CH32	*IVP	Input voltage FVC output	Is 38 kHz for input line voltage 380 V.				
SLP	SLP	Slip pulse	Pulse width 3.2 μ s.				

Name of terminal	Name of signal	Signal data	Remarks
ARS	ARS	Alarm reset terminal	Is this terminal is command to (0) terminal alarm is ignored and "ENABLE" is set.
CLK	CLK	Clock signal	312.5 kHz and pulse width 200 ns.
+24	24 V	+24 V voltage source	+20 V \pm 0.2 V.
+15	15 V	+15 V voltage source	+15 V \pm 0.15 V.
+5	5 V	+5 V voltage source	+5 V \pm 0.05 V.
0 V	0 V	P.C.B. reference voltage	
-15	-15 V	-15 V voltage source	-15 V \pm 0.15 V.

2. CHECK TERMINAL DATA CONFIRMATION METHOD

Terminal	Voltage check by a circuit tester or the like, or frequency check by a counter or the like	Waveform check during stop	Waveform check during low-speed rotation	Waveform check during acceleration/deceleration
CH1	0 - +10V by velocity command voltage input			
CH2	0 - +10V by velocity command			
CH3 CH4 CH5 CH6 CH7 CH8			See (2)	
CH9	0.3V by standard adjustment			
CH10	1.5V (standard) when velocity command voltage is 10V			
CH11				See (3)
CH13	0 - +10V by velocity command voltage input			
CH14 CH15			See (2)	
CH17				See (3)
CH18	+1.38 +0.03V at motor rotation +4.5 rpm			
CH19				
CH20	0 - +10V by rotation speed			
CH28				
CH21	Standard -8.2V (during low-speed rotation)			
CH22 CH24 CH26 CH29 CH30 CH31 CH23 SLP			See (2)	

Terminal	Voltage check by a circuit tester or the like, or frequency check by a counter or the like	Waveform check during stop	Waveform check during low-speed rotation	Waveform check during acceleration/deceleration
CH25 CLK		See (1)		
+24 +15 +5 -15	At AC200V input, +24.7 \pm 1V +15.0 \pm 0.45V + 5.0 \pm 0.05V -15.0 \pm 0.45V			
19A CT 19B	AC19V at AC200V input between 19A and CT AC19V at AC200V input between 19B and CT			
CH32	24kHz at AC200V input			

1) Waveform at stopping

Check terminal	Waveform	Remarks
CLK		
CH25		

2) Waveform during low speed

Condition: Motor rpm. 45~1000 rpm

Spindle reverse rotation command signal SRV ON

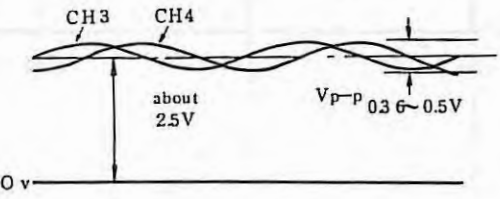
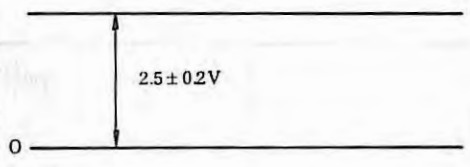
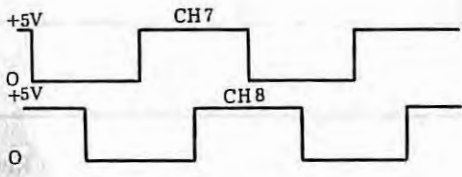
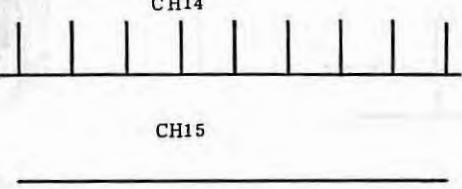
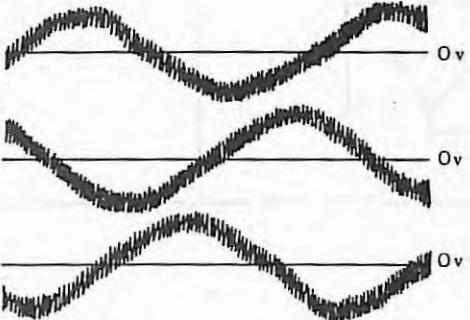
Check terminal	Waveform	Remarks
CH3 CH4		
CH5 CH6		
CH7 CH8		Set the ON/OFF duty of CH7 and CH8 waveform 1 to 1 by RV18 and RV19 at 1000 rpm.
CH14 CH15		When spindle rotation direction is reverse, waveform appears at CH15 and not appears at CH14.
CH22 CH24 CH26		If spindle rotation direction is reverse, phase of CH24 and CH26 are replaced.

Check terminal	Waveform	Remarks
CH29 CH30 CH31		<p>If spindle rotation direction is reverse, phase of CH30 and CH31 are replaced.</p> <p>Frequency is in proportion to spindle rotation.</p> <p>When unit and motor is normal, Sine-wave appears at check point.</p>
CH23 SLP		<p>Pulse number are changed in proportion to voltage of CH28 terminal.</p>

3) Waveform during acceleration/deceleration

Conditions: Motor revolutions 0 → 1000 rpm → 0 rpm

Spindle reverse rotation command signal (SRV) OFF → ON → OFF

Check terminal	Waveform	Remarks
CH13 CH20		
CH11 CH17 CH18		

Check terminal	Waveform	Remarks
CH19 CH28		

3. DIGITAL AC SPINDLE (Model 3 to 22)

3.1 Check Terminal

Table 9.3.1 Check terminal (digital spindle)

Name of terminal	Signal data	Remarks
DA1	D/A converter output voltage	0 - +10 V
DA2	Analog command voltage	0 - +10 V
PA	Pulse generator output A-phase	PA leads PB by 90° in CW rotation
PB	Pulse generator output B-phase	PB leads PA by 90° in CW rotation
RA	A-phase reference voltage	+2.5 V
RB	B-phase reference voltage	+2.5 V
PAP	A-phase square wave	Duty = 50%
PBP	B-phase square wave	Duty = 50%
PAS	A-phase signal	Waveform of the signal PA 10 times amplified when based on RA
PBS	B-phase signal	Waveform of the signal PB 10 times amplified when based on PR
TS1F	Forward rotation speed detection signal	+0.82 V at 6000 rpm in CCW (forward) rotation
TS1R	Reverse rotation speed detection signal	+0.82 V at 6000 rpm in CW (reverse) rotation

Name of terminal	Signal data	Remarks												
TS2	Low speed detection signal	+1.4 V at 22.5 rpm in CW (forward) rotation												
TS3	Velocity pulse F/V signal	-4.65V - -6.15 V at 6000 rpm in CCW (forward) rotation												
VCMD	Velocity command voltage	0 - +10 V, +: CCW -: CW												
FWP	Forward rotation speed pulse	Pulse width 3.2 μ s generated during forward rotation only												
RVP	Reverse rotation speed pulse	Pulse width 3.2 μ s generated during reverse rotation only												
ER	Error voltage	-4.2 V - +4.8 V												
CLK1	Clock signal	2.5 MHz, Duty = 50%												
SLIP	Slip pulse													
VDC	DC link voltage signal	Signal divided by 100 of DC link voltage												
ADIN	AC converter input signal													
IU	U phase current signal	<table border="1"> <thead> <tr> <th>Model</th> <th>3/6</th> <th>8</th> <th>12</th> <th>15/18</th> <th>22</th> </tr> </thead> <tbody> <tr> <td>Value of current</td> <td>22</td> <td>33</td> <td>48</td> <td>67</td> <td>83</td> </tr> </tbody> </table> <p style="text-align: right;">Unit: A/V</p>	Model	3/6	8	12	15/18	22	Value of current	22	33	48	67	83
Model	3/6		8	12	15/18	22								
Value of current	22		33	48	67	83								
IV	V phase current signal													
IW	W phase current signal													
+24	+24 V													
+15	+15 V	+15 V												
+5	+5 V	+5 V												
-15	-15 V	-15 V												
0 V	0 V	0 V												

3.2 Waveform at Check Terminal

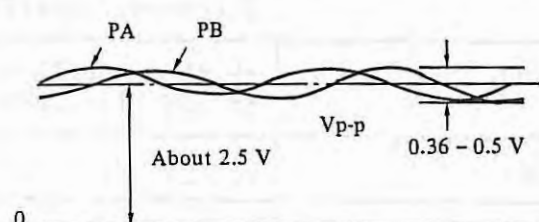
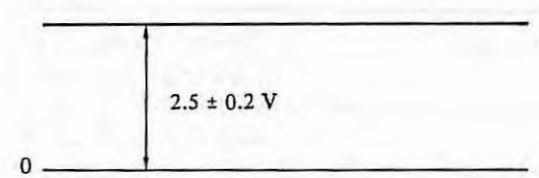
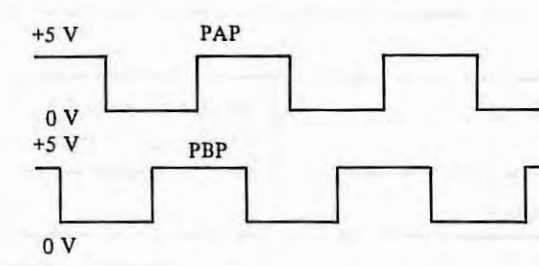
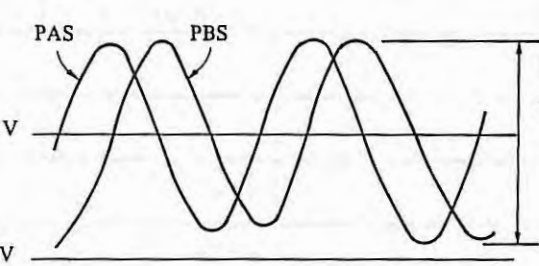
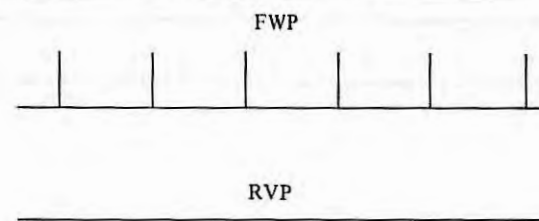
Check terminal	Waveform	Remarks
PA PB		
RA RB		
PAP PBP		
PAS PBS		
FWP RVP		<p>When spindle rotation direction is forward. The waveform appears at RVP and not appears at FWP in reverse rotation.</p>

Check terminal	Waveform	Remarks
VCMD TSA TS1R TS2 TS3 ER	<p>0 V -10 V +10 V 0 V +0.8 V 0 V +14 V 0 V +5.0 V 0 V +4.8 V 0 V -4.2 V</p>	
IU IV IW	<p>0 V 0 V 0 V</p>	
CLK1	<p>4 V 0 V 200ns 200ns 400ns</p>	2.5 MHz

4. DIGITAL AC SPINDLE (Model 1S, 1.5S, 2S, 3S, 2H, 2VH)



4.1 Check Terminal Table

Check terminal	Signal data	Remarks
DA2	Analog speed command voltage	0 - +10 V
PA	Pulse generator output phase A	90° leading from PB at CW rotation
PB	Pulse generator output phase B	90° leading from PA at CW rotation
RA	Phase A reference voltage	+2.5 V
RB	Phase B reference voltage	+2.5 V
PAP	Phase A square wave	Duty = 50%
PBP	Phase B square wave	Duty = 50%
TSA	Speed detecting signal	+10 V at rated maximum speed rpm
TS2	Low speed detecting signal	Adjusted by RV6 according to the model
TS3	Speed pulse F/V signal	-4.65 - 6.15 V at CCW (forward rotation) 6000 rpm
VCMD	Velocity command voltage	0 = +10 V, +: CCW, -: CW
FWP	Forward rotation speed pulse	Pulse width = 3.2 μs, produced only at forward rotation
RVP	Reverse rotation speed pulse	Pulse width = 3.2 μs, produced only at reverse rotation
ER	Error voltage	-4.2 V - +4.8 V
CLK1	Clock signal	2.5 MHz, Duty = 50%
SLIP	Slip pulse	
VDC	DC link voltage signal	1/100 signal of DC link voltage
DTDC	DC voltage of input AC voltage	1/100 signal of DC voltage of input AC voltage

Check terminal	Signal data	Remarks
IU	Phase U current signal	Current value 22.2 A/V
IV	Phase V current signal	
IW	Phase W current signal	
+24	+24 V	+24 V
+15	+15 V	+15 V
+5	+5 V	+5 V
-15	-15 V	-15 V
0V	0 V	0 V
SM	Signal for speedmeter	Rated maximum speed +10 V
LM	Signal for load meter	+10 V at maximum output

4.2 Waveform of Check Terminal

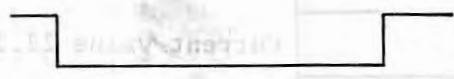
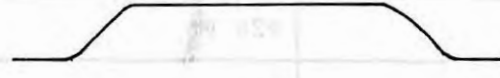
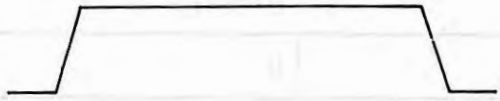
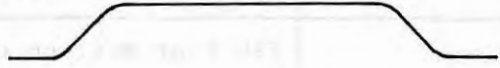
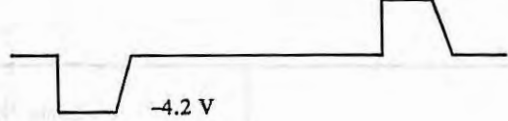
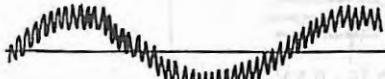
Check terminal	Waveform	Remarks
PA PB		
RA RB		
PAP PBP		

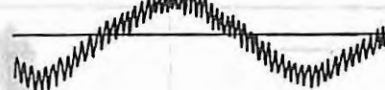
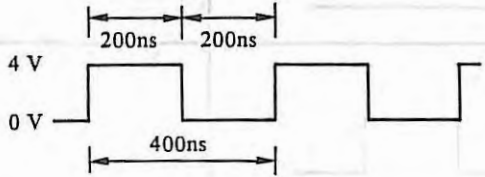
Check terminal	Waveform	Remarks
VCMD	 <p>0 V -10 V</p>	
TSA	 <p>+10 V 0 V</p>	
TS2	 <p>+14 V 0 V</p>	
TS3	 <p>+5.0 V 0 V</p>	
ER	 <p>+4.8 V -4.2 V 0 V</p>	
IU	 <p>0 V</p>	
IV	 <p>0 V</p>	
IW	 <p>0 V</p>	
CLK1	 <p>4 V 0 V 200ns 200ns 400ns</p>	2.5 MHz

APPENDIX.10 MAGNETIC SENSOR SIGNALS CHECKING METHOD

1. APPLICATION

This document applies to the following check procedure by observing output signals of the magnetic sensor (specification: A57L-0001-0037) employed for magnetic sensor system spindle orientation.

Item	Check item
1	Whether magnetizer, magnetic sensor head, and magnetic sensor amplifier are defective or not.
2	Whether magnetizer and magnetic sensor head are properly mounted or not;
3	Whether magnetic sensor signal cables are properly connected without any connection failure and short-circuit.

2. CHECK PROCEDURE

1) Preparation

- ① Rotate the spindle at about 120rpm. Select the counterclockwise rotating direction as viewed from the AC spindle motor shaft (in such a direction as the voltage at check terminal CH13 (VCMD) of AC spindle control circuit PCB becomes positive (+) to CH16 (OV)).

Note) MODEL 1, 2, small MODEL 3 ... A16B-1100-0080, -0090~0092

MODEL 3~12 ... A20B-1000-0690~0693

MODEL 15~22 ... A20B-0009-0534~0539

MODEL 30, 40 ... A20B-1000-0700~0701

- ② Check the peak voltage and offset voltage levels of the following signal waveforms at the check terminals of the orientation circuit (drawing: A20B-0008-0030~1 or A20B-0009-0520) using an oscilloscope. The names of check terminals and signal contents are common, irrespective of the kinds of orientation circuit.

Check terminal No.	Signal name	Symbol	Prove common terminal
CH1	Magnetic sensor output signal A	MSA	(OV)
CH2	Magnetic sensor output signal B	LSA	

2) Decision method

1 Examples of normal waveforms and their criteria are as shown below.

If a trouble occurred, refer to the causes and remedy shown in the following table.

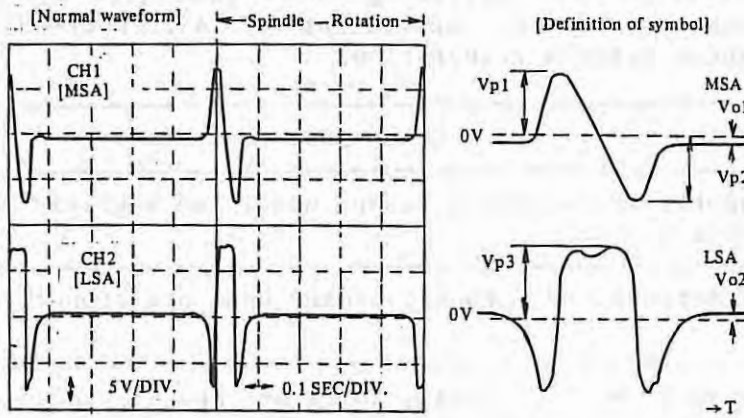

(Criteria table)

Item	Criteria (normal, if these conditions are satisfied.)
Offset voltage	$V_{o1\sim 2} < 0.5V$
Peak voltage	$3V < V_{p1\sim 2} < 10V$

2 Remedy to be observed when the above criteria are not satisfied.

Item	Symptoms	Causes	Remedy
1	Offset voltage of either or both signals is high. Offset voltage is normal. Peak voltage of either signal only is low.	a. Magnetic sensor head or magnetic sensor amplifier is defective.	Replace defective parts.
2	Waveform of either signal does not appear, or waveform of both signals don't appear.	a. Magnetic sensor head, amplifier, or magnetic sensor amplifier is defective. b. Poor connection or short-circuit of cables or connectors.	a. Replace defective parts. b. Repair defective parts.
3	Offset voltage is normal, but the entire peak voltage is low.	a. Mounting gap of the magnetic sensor head and the magnetizer is wider than specified.	Readjust the gap.

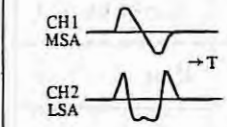
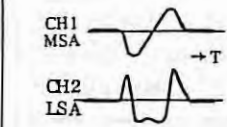
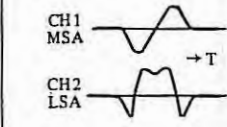
Item	Symptoms	Causes	Remedy
4	Offset voltage and peak voltage levels are normal, but waveforms are different from specified ones.	Observe the following procedure according to waveforms.	
Observation waveform		<p>a. Magnetic sensor head is not mounted properly.</p> <p>b. Wrong cable connection.</p>	<p>a. Reverse the pin groove direction of the magnetic sensor head.</p> <p>b. Replace LSA and LSB with each other.</p>
		<p>a. Magnetizer is not properly mounted.</p> <p>b. Wrong cable connection.</p>	<p>a. Reverse the direction of the reference hole of magnetizer.</p> <p>b. Replace MSA and MSB with each other. Replace LSA and LSB with each other.</p>
		<p>a. Magnetizer and magnetic sensor head are not properly mounted.</p> <p>b. Wrong cable connection.</p>	<p>a. Reverse the mounting directions of both magnetizer and magnetic sensor head.</p> <p>b. Replace MSA and MSB with each other.</p>

Reference) For normal mounting methods and connection methods of signal cables of the magnetizer and magnetic sensor head, refer to 7.3.1 in text and appendix 1 "Connections".

APPENDIX 11. PARAMETER LIST FOR DIGITAL AC SPINDLE SERVO UNIT

1) MODEL 3 to 22

Mode	Contents		Standard setting	Data	
F-00	Display of rotation number of motor				
F-01	Use/non-use of machine ready signal (MRDY)	Use : 1	1		
		Non-use: 1			
F-02	Use/non-use of override function	Use : 1	1		
		Non-use: 1			
F-03	Setting of override range	- 120% : 1	1		
		- 100% : 0			
F-04	Setting of velocity command voltage	Use of external analog command: 0	0		
		Use of DA converter : 1			
F-05	Setting of maximum rotation number		Based on the motor specification		
	Standard specification	High speed specification			Setting
	- 5000 rpm	- 10000 rpm			0
	- 6000 rpm	- 12000 rpm			1
		- 15000 rpm			2
	- 20000 rpm	3			
F-06	Pattern setting of output limit		0		
	Contents				Setting
	No output limiting made				0
	Output limit is made only at acceleration/deceleration				1
	Output limit is made only at normal rotation, not at acceleration/deceleration				2
Output limit is made for all operations		3			
F-07	Setting of limit value at output limit	Rated maximum output is 100	100		

Mode	Contents	Standard setting	Data
F-08	Setting of delay time before shut-off of motor power Delay time = (Set value) x 40 msec.	5	
F-09	Use/non-use of shut-off of motor power by machine ready signal (MRDY)	Use : 1	0
		Non-use: 0	
F-10	Velocity deviation offset adjustment at forward rotation command (SFR)	128	
F-11	Velocity deviation offset adjustment at reverse rotation command (SRV)	128	
F-12	Velocity deviation offset adjustment at orientation command (OCR)	128	
F-13	Rotation number adjustment at forward rotation	Based on the motor specification	
F-14	Rotation number adjustment at reverse rotation		
F-15	Rotation number at velocity command voltage, 10 V Rotation number = (Set value) x 100 rpm		
F-16	Detection range of velocity arrival signal Detection range = Within \pm (Set value)% of command rotation number	15	
F-17	Detection level of velocity detection signal Detection range = Less than (Set value)% of maximum rotation number	3	
F-18	Setting of torque limit value Torque limit value = Less than (Set value)% of maximum output	50	
F-19	Setting of time needed for acceleration/deceleration Time = (Set value) sec.	10	
F-20	Limiting of regenerated power Setting = 0 - 100 (Adjustment of deceleration time), range	60	
F-21	Setting of velocity control phase compensation P: HIGH gear (CTH = 1)	50	
F-22	Setting of velocity control phase compensation P: LOW gear (CTH = 0)	50	
F-23	Setting of velocity control phase compensation P at orientation: HIGH gear	100	
F-24	Setting of velocity control phase compensation P at orientation: LOW gear	100	

Mode	Contents	Standard setting	Data
F-25	Setting of velocity control phase compensation I: HIGH gear (CTH = 1)	30	
F-26	Setting of velocity control phase compensation I: LOW gear (CTH = 0)	30	
F-27	Setting of velocity control phase compensation I at orientation: HIGH gear	30	
F-28	Setting of velocity control phase compensation I at orientation: LOW gear	30	
F-29	Adjustment of velocity detection offset (adjusted at shipping)	Approx. 128	
F-30	Adjustment of rotation number display (adjusted at shipping)	Approx. 3990	
F-31	Setting of rigid tap mode	0	
F-32	Setting of normal motor voltage	10	
F-33	Setting of motor voltage at orientation	10	
F-34	Setting of motor voltage at rigid tap mode	100	
F-35	Setting of speed zero signal detection level detection level = less than {max. number of revolution x (Setting data/100)%}	75	

2) MODEL 1S, 1.5S, 2S, 3S, 2H, 2VH

Mode	Contents	Standard setting	Data																		
F-00	Speed indication of motor																				
F-01	The use/no use of the machine ready signal (MRDY)	Use : 1	1																		
		No use: 0																			
F-01 to F-05	Not used																				
F-06	Pattern setting of output limit	0																			
	<table border="1"> <thead> <tr> <th rowspan="2">Contents</th> <th colspan="2">Setting</th> </tr> <tr> <th>Pattern 1</th> <th>Pattern 2</th> </tr> </thead> <tbody> <tr> <td>The output is not limited</td> <td>0</td> <td>0</td> </tr> <tr> <td>The output is limited only at acceleration and deceleration</td> <td>1</td> <td>4</td> </tr> <tr> <td>No output is limited at acceleration and deceleration but it is limited only during steady rotation</td> <td>2</td> <td>5</td> </tr> <tr> <td>The output is limited over all movements</td> <td>3</td> <td>6</td> </tr> </tbody> </table>			Contents	Setting		Pattern 1	Pattern 2	The output is not limited	0	0	The output is limited only at acceleration and deceleration	1	4	No output is limited at acceleration and deceleration but it is limited only during steady rotation	2	5	The output is limited over all movements	3	6	
	Contents				Setting																
				Pattern 1	Pattern 2																
	The output is not limited			0	0																
The output is limited only at acceleration and deceleration	1	4																			
No output is limited at acceleration and deceleration but it is limited only during steady rotation	2	5																			
The output is limited over all movements	3	6																			
F-07	Limit value setting when the output is limited	100																			
F-08	Setting of delay time to motor power interruption Delay time = (Setting value) x 40 msec	5																			
F-09	Use or no use of motor power interruption by machine ready signal MRDY	Use : 1	0																		
		No use: 0																			
F-10	Speed error offset adjustment at the time of the forward rotation command (SFR)	128																			
F-11	Speed error offset adjustment at the time of the reverse rotation command (SRV)	128																			
F-12	Speed error offset adjustment at the time of the orientation command (ORCM)	128																			
F-13 to F-14	Not used (The speed rpm should be adjusted, using RV1 and 2 in reference with item 4.5.)																				
F-15	Speed rpm at 10 V speed command voltage (Speed rpm = (preset value) x 100 rpm)																				

Mode	Contents	Standard setting	Data
F-16	Detection range of speed arrival signal: Detection range = within \pm (preset value)% of command speed rpm	15	
F-17	Detection level of speed detecting signal: Detection range = Less than (preset value)% of maximum speed	3	
F-18	Setting of torque limit value: Torque limit value = Less than (preset value)% of maximum output	50	
F-19	Setting of time for acceleration/deceleration Time = (Setting value) sec.	10	
F-20	Limit of regenerative power (Adjustment of deceleration time) Setting range = 0 - 100	60	
F-21	Setting of velocity control phase compensation P: HIGH gear (CTH = 1)	20	
F-22	Setting of velocity control phase compensation P: LOW gear (CTH = 0)	20	
F-23	Setting of velocity control phase compensation P is orientation time: HIGH gear	40	
F-24	Setting of velocity control phase compensation P in orientation time LOW gear	40	
F-25	Setting of velocity control phase compensation I: HIGH gear (CTH = 1)	10	
F-26	Setting of velocity control phase compensation I: LOW gear (CTH = 0)	10	
F-27	Setting of velocity control phase compensation I in orientation time: HIGH gear	10	
F-28	Setting of velocity control phase compensation I in orientation time: LOW gear	10	
F-29	Not used		
F-30	(The adjustment of the speed detection offset is explained in item 4.5. Please adjust by RV3)		
F-31	Setting of rigid tap mode	0	
F-32	Setting of usual motor voltage	10	
F-33	Setting of motor voltage in orientation time	10	
F-34	Setting of motor voltage of rigid tap mode	100	

Mode	Contents	Standard setting	Data
F-35	0 speed signal detection level: Detection range = Less than (Preset value/100)% of maximum speed	75	
F-36	Load detection signal level: Detection range = Less than (Preset value/100)% of maximum output	90	

Revision Record

FANUC AC SPINDLE SERVO UNIT MAINTENANCE MANUAL (B-53425E)

05	1, '84	Adding of small type servo unit (A06B-6044-H108, H112) for motor MODEL 8 and 12.			
04	11, '83	All contents are changed.	09	3, '87	<ul style="list-style-type: none"> ● Adding of Digital AC spindle servo unit MODEL 1S, 1.5S, 2S, 3S, 2H, 2VH. ● Adding of 380V/415V AC input type AC spindle servo unit.
03	8, '82	All contents are changed.	08	11, '86	<ul style="list-style-type: none"> ● Adding parameter F 35 ● Adding of check terminal table and waveform at check terminal for digital spindle.
02	11, '81	Correction of errata	07	8, '86	<ul style="list-style-type: none"> ● Adding digital AC spindle servo unit.
01	9, '81		06	6, '85	<ul style="list-style-type: none"> ● Adding the contents of AC spindle motor model 1, 2, 30, 40. ● Adding the contents of AC spindle servo unit model 1, 2, small model 3, 30, 40.
Edition	Date	Contents	Edition	Date	Contents