

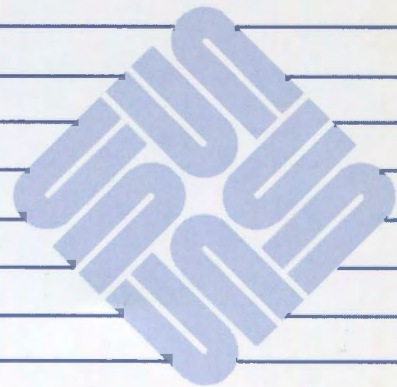

---

# Sun™ Full-Height Rack System Installation Manual





# Sun™ Full-Height Rack System Installation Manual

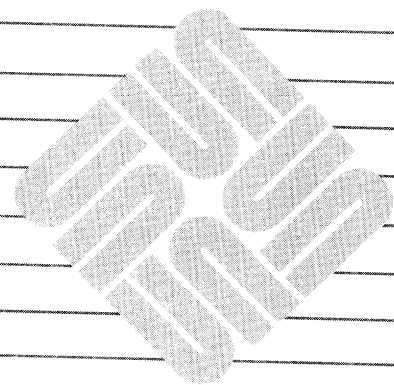

# Credits and Trademarks

**Multibus** is a trademark of Intel Corporation.

**Sun, Sun Microsystems** and **Sun Workstation** are registered trademarks of Sun Microsystems, Incorporated.

The Sun logo  is a registered trademark of Sun Microsystems, Inc.

**Sun-2, Sun-2/xxx, Sun-3/xxx, Sun-4/xxx, Deskside, SunStation, SunCore, SunWindows, and DVMA** are trademarks of Sun Microsystems, Incorporated.

**UNIX** is a trademark of AT&T Bell Laboratories.

This equipment generates, uses, and can radiate radio frequency energy and if not installed and used in accordance with the instructions manual, may cause interference to radio communications. It has been tested and found to comply with the limits for a Class A computing device pursuant to Subpart J of Part 15 of FCC Rules, which are designed to provide reasonable protection against such interference when operated in a commercial environment. Operation of this equipment in a residential area is likely to cause interference in which case the user at his or her own expense will be required to take whatever measures may be required to correct the interference.

## WARNING

The CPU board installed in this enclosure may have an on-board Lithium Battery, Matsushita Electric Type No. BR2325. This battery is **not** a customer-replaceable part. The battery will be marked as follows: "Warning - Replace battery with MATSUSHITA ELECTRIC or PANASONIC part No. BR2325 only. Use of another battery may present a risk of fire or explosion." The battery may explode if mis-treated. Do not dispose of in fire, attempt to recharge, or disassemble the battery.

Copyright © 1987, 1988 by Sun Microsystems, Inc.

This publication is protected by Federal Copyright Law, with all rights reserved. No part of this publication may be reproduced, stored in a retrieval system, translated, transcribed, or transmitted, in any form, or by any means manual, electric, electronic, electro-magnetic, mechanical, chemical, optical, or otherwise, without prior explicit written permission from Sun Microsystems.

---

# Contents

Preface .....	vii
<b>Chapter 1 The Sun Full-Height Rack System .....</b>	<b>3</b>
1.1. Introduction .....	3
1.2. Tools Needed .....	3
1.3. Unpacking Instructions (European Only) .....	3
<b>Chapter 2 System Setup .....</b>	<b>7</b>
2.1. Positioning the Sun Rack .....	7
<b>Chapter 3 Unpacking the Line Cord .....</b>	<b>13</b>
3.1. Unpacking Procedure .....	13
<b>Chapter 4 Unlocking the Disk Drive Heads .....</b>	<b>17</b>
4.1. Head Unlock Procedure .....	17
<b>Chapter 5 Line Power Connection .....</b>	<b>25</b>
5.1. Safety Precautions .....	25
5.2. Connection Procedure .....	26
5.3. Power Requirements .....	27
<b>Chapter 6 Power Controller .....</b>	<b>31</b>
6.1. Controller Operation .....	31
<b>Chapter 7 Cable Routing and Cooling .....</b>	<b>35</b>
7.1. RF Emission .....	35

7.2. Cooling and Airflow ..... 35  
7.3. After the Installation is Complete ..... 35

---

## Figures

Figure 1-1 Unpacking the Rack .....	4
Figure 2-1 Sun Rack Leveler Foot .....	8
Figure 2-2 Stabilizer Bar .....	9
Figure 4-1 Connectors on the Rear of Disk Drive Cover .....	18
Figure 4-2 Disk Drive Retaining Screws .....	19
Figure 4-3 Disk Drive Head Lock Access Cover .....	20
Figure 4-4 Location of the Disk Drive Head-Lock Lever .....	21
Figure 5-1 Power Controller Control Panel .....	26
Figure 6-1 Connections to the 100-120V Domestic Power Controller .....	31
Figure 6-2 Connections to the 200-240V Domestic Power Controller .....	32
Figure 6-3 Connections to the 220-240V European Power Controller .....	32



---

## Preface

This manual (P/N 800-1677-xx) provides information for customers who have purchased the Sun Full-Height Rack System. By using this manual and the additional documentation shipped with your unit (listed below), you should be able to get your rack system set up and running properly.

At the end of this manual we have included a “reader comments sheet.” Any suggestions and constructive criticism you may have concerning omissions, errors, or accuracy in this manual would be greatly appreciated. Your responses on this comment sheet will help keep our documentation accurate and up to date.

**Applicable Sun Documents.** Documents which contain information necessary or helpful for the installation and operation of the Sun Full-Height Rack System are listed below.

1. *Cardcage Slot Assignments and Backplane Configuration Procedures.*
2. *Installing UNIX on the Sun Workstation.*
3. *System Administration for the Sun Workstation.*
4. *System Managers Manual for the Sun Workstation.*
5. *Installation Manual for the Sun 12-Slot Deskside Logic Enclosure.*
6. *Installation and Service Manual for the Sun-3/180 Tape Drive Option.*
7. *Installation Manual for Sun Rackmountable Fileservers.*
8. *Sun 900Mb Disk Drive Field Service and Installation Manual.*
9. *Installation Manual for the Sun 575 Mb Disk Drive.*
10. *Fujitsu GCR Tape Drive Hardware Installation Manual.*

In addition to the above documentation, your rackmount system will be shipped with an installation document that is specifically for the CPU board you ordered.

**CAUTION** Springfingers are metal strips that are installed between the edge of the PC board and the outer panel to reduce RFI emissions. Serrated metal “fingers”



protrude from either side of the strip.

**If a board WITH springfingers is installed next to a board WITHOUT spring fingers, the insulator shield on the outside of the fingers MUST be present to prevent possible shorting of component leads to the springfingers. Installation of a board WITHOUT springfingers may affect RFI emissions and may therefore affect FCC compliance. Sun will no longer be responsible for FCC compliance if non-springfingered boards are added to a system originally shipped WITH springfingers and FCC approval.**

In the case of a logic enclosure containing boards WITH and WITHOUT springfingers use the following guidelines:

- Before removing a board WITHOUT springfingers, remove the board to the left if it is equipped WITH springfingers and an outer insulator shield.
- Replace any filler panel equipped WITH springfingers by pulling out the air restrictor panel far enough to allow the springfingers to lay against the panel. Push both units into place simultaneously and fasten with the appropriate fasteners. This procedure makes replacement of the filler panels easier, and reduces the chance of damage to the springfingers.
- Always install a board WITHOUT springfingers first, and then replace the board WITH springfingers and insulator shield in the slot on the left.

**If a board with springfingers is installed next to a board or filler panel also equipped with springfingers, the outside insulator shields should be removed.**

**Ensure that the insulator strip between the inner side of the springfingers and the PC board is in place and intact at all times.**

**When removing and replacing boards with springfingers, check the condition of the insulator strip/shield(s) and replace if damaged.**

**Call 800 USA-4SUN with any questions, or for information on how to obtain additional insulator strips or shields.**

**Some of the devices on Sun boards are very sensitive to electro-static discharge, that can be built up in your body and discharge when you touch the board. Before handling any board, make sure that you have placed your hand on a conductive surface that is grounded to a common earth ground, (such as the metal screws on an AC receptacle cover) to discharge any static electricity present in your body.**

---

## The Sun Full-Height Rack System

The Sun Full-Height Rack System .....	3
1.1. Introduction .....	3
1.2. Tools Needed .....	3
1.3. Unpacking Instructions (European Only) .....	3

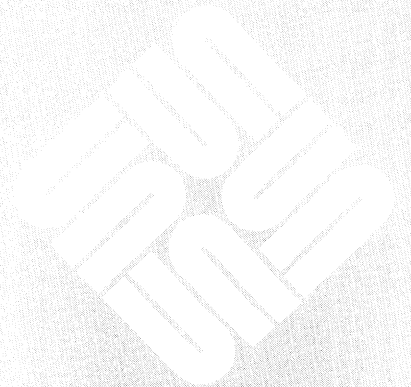



---

# The Sun Full-Height Rack System

## 1.1. Introduction

This installation manual describes the

- set-up procedures,
- power-up procedures,
- cable routing,
- power requirements, and
- cooling/airflow

of the Sun Full-Height Rack system.

## 1.2. Tools Needed

The following tools will be needed to install the Sun Full-height Rack:

- wire cutter — to cut tie wraps
- flat blade screwdriver
- Phillips #2 screwdriver
- flashlight — may be needed to view interior of the rack
- slip-joint pliers or adjustable end wrench.
- hex-head wrench — shipped with your system
- set of keys — shipped with your system

**NOTE** *Any document entitled “Read Me First” or “Read This First” that is shipped with your system should be read before you set up your system and load the software.*

## 1.3. Unpacking Instructions (European Only)

**CAUTION** At least two people will be needed to unpack the Rack from its shipping crate.

1. Remove the 9/16" lag bolts from the lower front and back panels of the shipping crate.
2. Remove the eight retainer clips (4 on each side) from the front panel of the crate.
3. Remove the eight retainer clips (4 on each side) from the sides of the crate.
4. Remove the front panel of the shipping crate and set it aside. The front panel will be used later as a ramp to roll the unit out of the crate.
5. As one piece, lift away the top, sides, and back of the crate from the base.
6. Get the front panel of the shipping crate (from Step 4). Using the front panel as a ramp, place it against the base. Make sure the hinged edge is extended.
7. Remove the four lag bolts securing the pallet's forward restraint.
8. Cut the crate's banding. Take *great* care to restrict the banding so that it doesn't lash out and hit anyone or anything, when it is cut.
9. Carefully roll the rack down the ramp, ensuring that control of the rack's velocity is maintained.
10. Position the rack into the desired end-use position.
11. Remove the anti-static bag.
12. Retain all shipping materials for future transport of the rack.

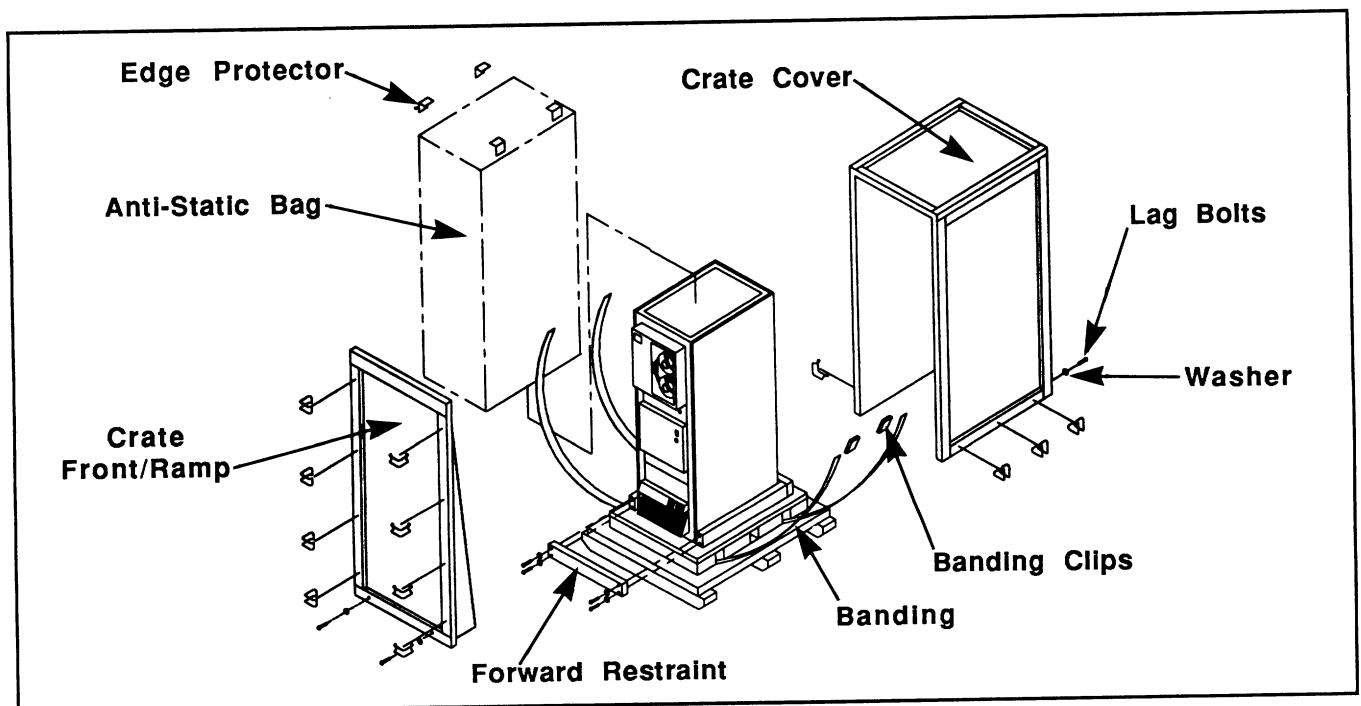
Figure 1-1 *Unpacking the Rack*

---

## System Setup

System Setup .....	7
2.1. Positioning the Sun Rack .....	7

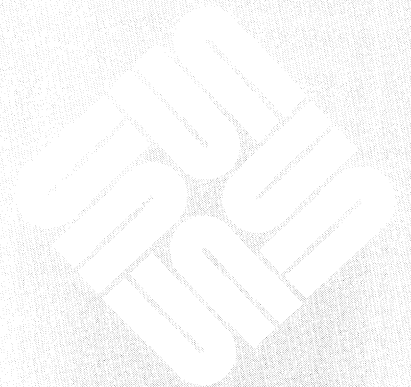



---

## System Setup

*NOTE* Since the Sun Full-height Rack described here was shipped in a padded van and unpacked at your company, general unpacking instructions are not included. Instead, these instructions begin by describing system set-up procedures, after the system has been unloaded and unpacked.

### 2.1. Positioning the Sun Rack

**CAUTION** If your rack system comes equipped with Fujitsu 2351A (380MB) disk drives make sure the heads are still locked! The disk drive could be seriously damaged if the heads have already been unlocked. See the section entitled "Unlocking the Disk Drive Heads", for a description of locked and unlocked positions.

1. Place the system where you want it, but make sure that it is positioned at least **three (3) feet** from the wall.
2. There are four leveler feet which are threaded into the four bottom corners of the rack base (figure 2-1) threaded into the base of the rack. Unscrew these feet until **all four feet come in contact with the floor**. Be sure that the rack is level when the feet touch the floor. You must not be able to rock the cabinet back and forth or side to side.



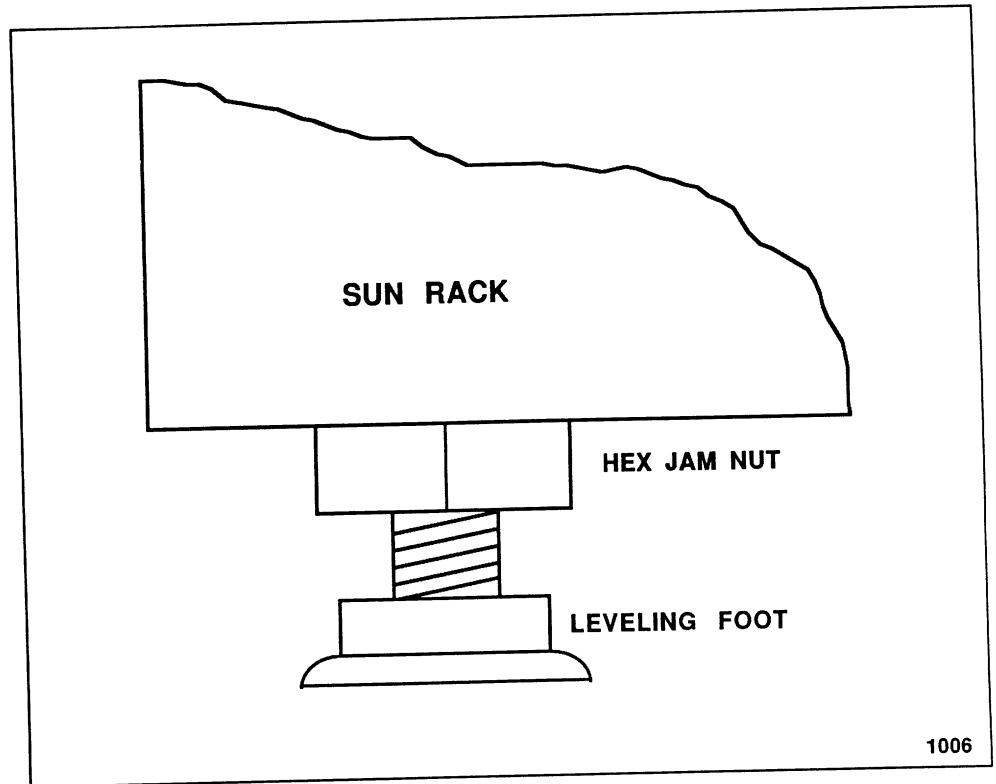

Figure 2-1 *Sun Rack Leveler Foot*

3. The leveler feet are adjusted by unscrewing the four hex jam nuts (one for each foot) and then screwing the four feet either up or down until the enclosure is level. When the enclosure is level all four feet will be securely on the floor, the disk drive will be parallel to the floor, and you will not be able to rock the rack either back and forth or from side to side.
4. When the four feet have been correctly adjusted, retighten the four hex jam nuts against the base of the rack.
5. A stabilizer bar is installed at the bottom front of the rack (figure 2-2). The stabilizer bar prevents unbalance of the rack when the disk drive chassis or the tape drive mechanism is pulled out from the rack. The stabilizer bar has two leveling feet at the outer end. Unscrew each foot until it is close to the floor, and then pull the stabilizer bar out to full extension. Adjust the feet until they touch the floor. Tighten the hex jam nuts.

**CAUTION** Do not over-tighten the stabilizer feet. The feet should not lift the rack front when properly adjusted. The stabilizer bar must be extended before attempting to service disks or the 1/2" tape drive.

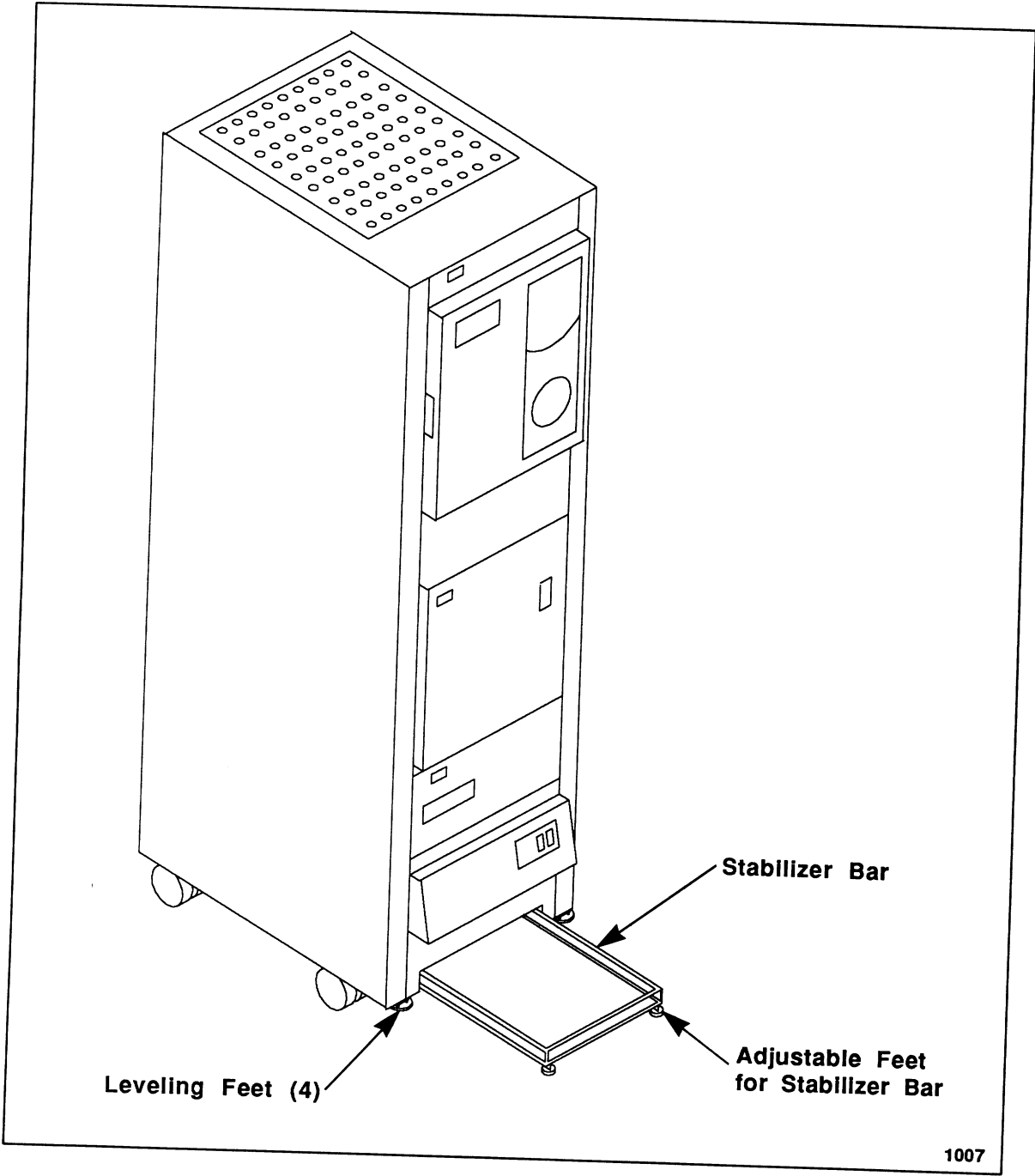

Figure 2-2 Stabilizer Bar



---

## Unpacking the Line Cord

Unpacking the Line Cord .....	13
3.1. Unpacking Procedure .....	13

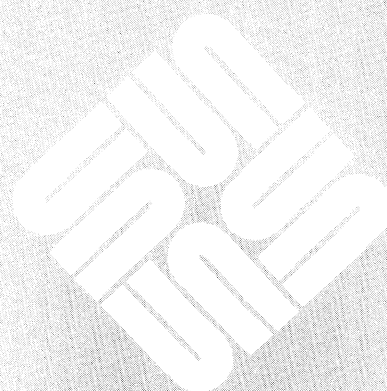



---

## Unpacking the Line Cord

### 3.1. Unpacking Procedure

Perform the procedure in the following paragraphs to unpack and properly route the AC line cord.

1. Gain access to the rear of the rack.

*NOTE* Use a screwdriver to release the four 1/4-turn screws securing the large filler panel covering the CPU chassis. Removal of other filler panels is done with a screwdriver also.

2. Locate the 15-foot line cord at the base of the unit. It is a thick cord, approximately three-quarters of an inch in diameter. You will find it threaded through the cable hatch and tie-wrapped to the inside RETMA rail for shipment.
3. Cut the tie-wrap which holds the 15-foot line cord to the RETMA rail, and unroll the cord.
4. Route the line cord back out through the cable hatch located at the lower rear filler panel of the unit.
5. Replace the filler panels.

**CAUTION** Do not plug the line cord into the wall yet!



---

## Unlocking the Disk Drive Heads

Unlocking the Disk Drive Heads ..... 17

4.1. Head Unlock Procedure ..... 17

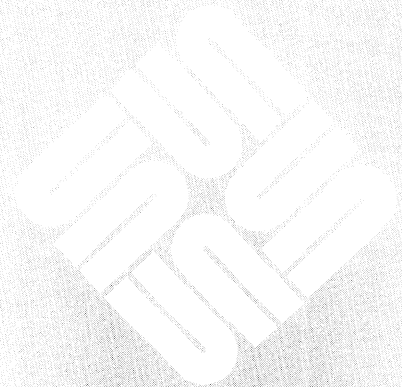





---

## Unlocking the Disk Drive Heads

- Fujitsu Model 2361A - The Fujitsu Model 2361A (575MB formatted capacity) disk drive heads are automatically locked and are not affected by this procedure.
- Hitachi 892 MB - Hitachi 892 MB disk drive heads are automatically locked at power off and unlocked at power on. They are not affected by this procedure.
- Fujitsu Model 2351A - The Fujitsu Model 2351A (380MB formatted capacity) disk drive heads are mechanically locked for shipment. The disk drive heads must be manually unlocked after the rack has been installed. Perform the procedure in paragraph 4.1, below, to unlock the Model 2351A disk drive heads only.

### 4.1. Head Unlock Procedure

1. Find the data and command cables (either white or grey cables) that run from the system CPU to the Model 2351A disk drive cover (figure 4-1). Disconnect cables *at the disk drive*.

*NOTE* If necessary, label the cables so that you will be able to replace them correctly.

**CAUTION** The rack base stabilizer bar must be fully extended and the feet adjusted before attempting to slide the disk drive out of the rack or open the tape drive door. Failure to extend the bar may allow the rack assembly to tip forward, causing injury or damage.

2. Two retaining screws prevent the disk drive from sliding. One screw is located on each side of the rear of the disk drive and attaches the disk drive to brackets on the RETMA rail (figure 4-2). Remove the two screws. Go to the front of the rackmount and pull the disk drive all the way out so that the head lock access cover (figure 4-3) of the disk drive can be opened.

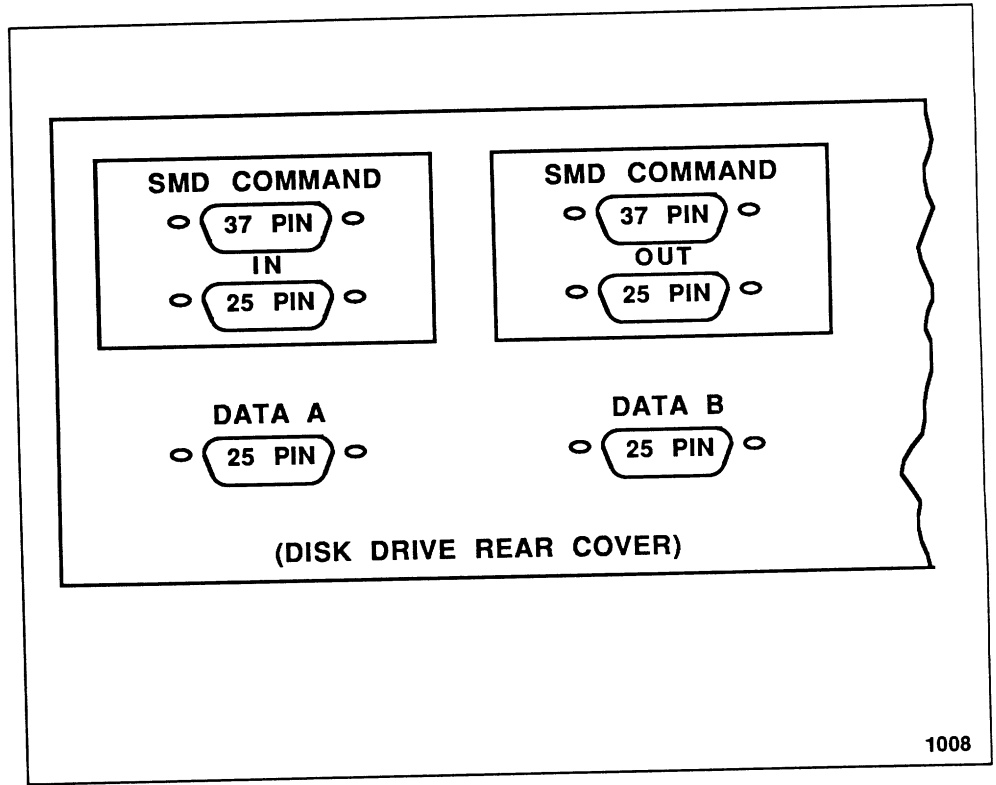

Figure 4-1 *Connectors on the Rear of Disk Drive Cover*

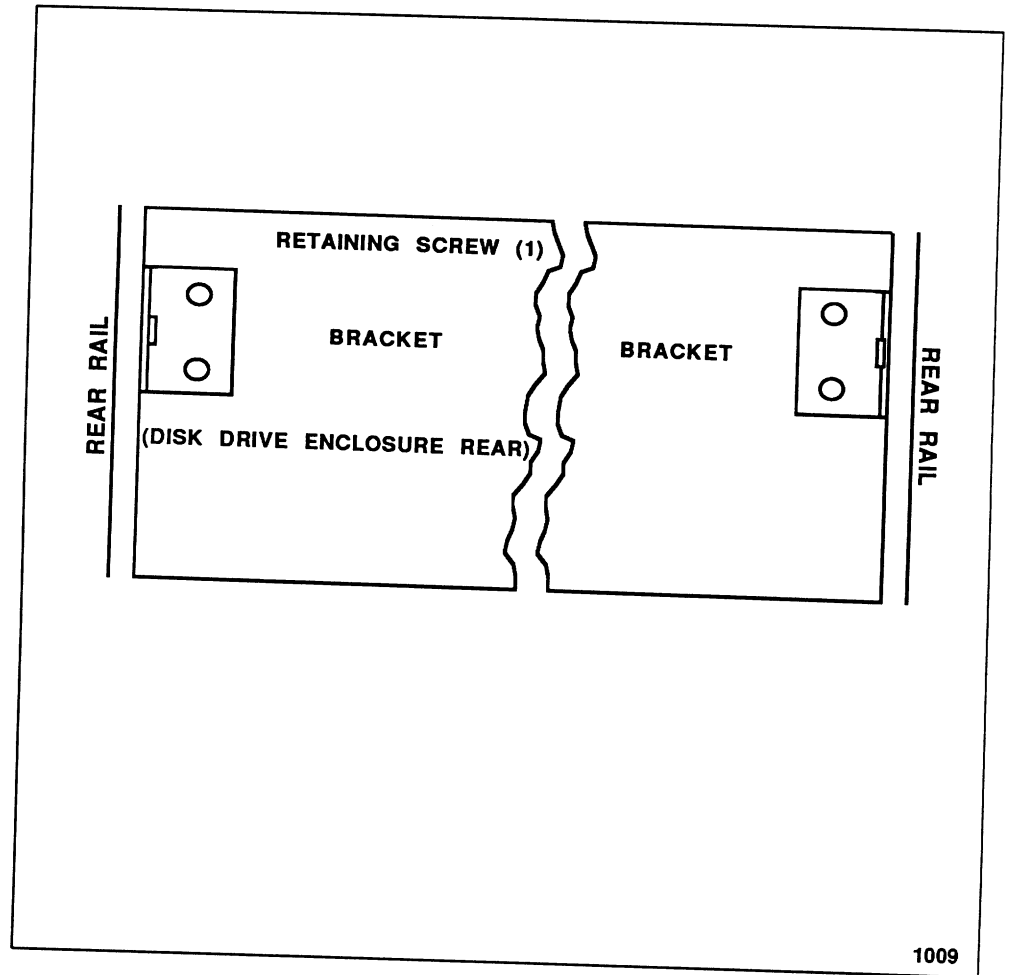

Figure 4-2 *Disk Drive Retaining Screws*

3. Remove two screws securing the head lock access cover plate on the disk drive cover. Open the access cover plate to expose the head lock lever.
4. Locate the head-lock lever—see figure 4-4. Note that the illustration is *intentionally* positioned upside-down; this is the way the disk drive appears to you from the front of the rackmount.

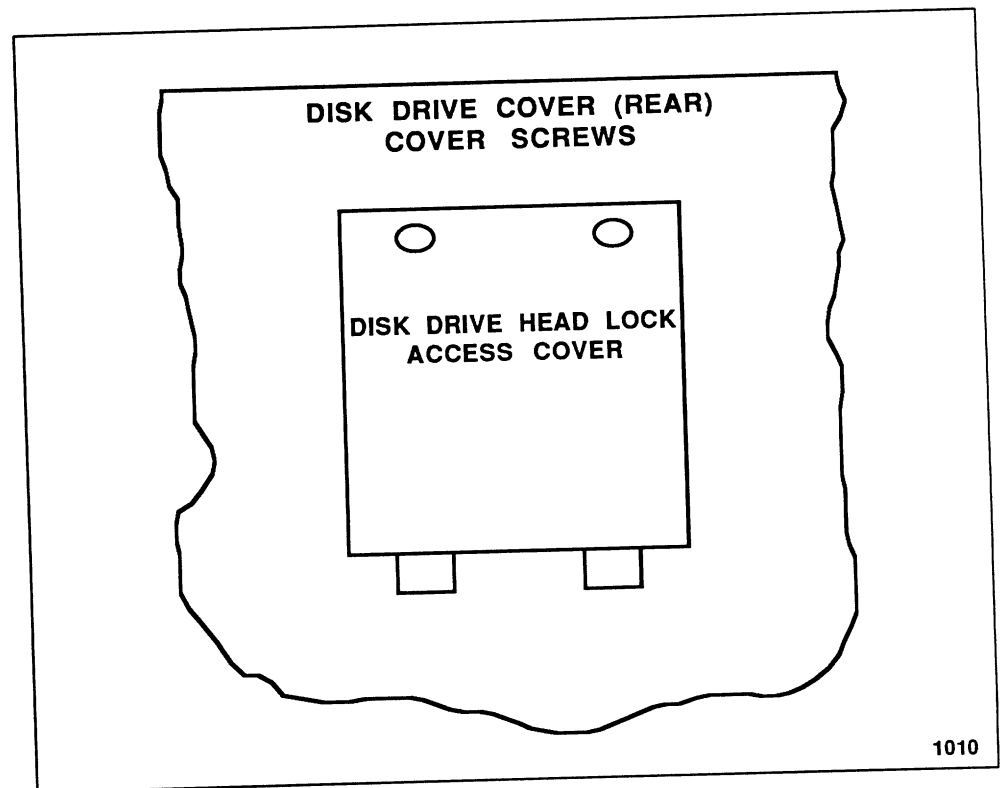

Figure 4-3 *Disk Drive Head Lock Access Cover*

5. Using figure 4-4 as a guide, locate the locking lever screw and loosen it enough to allow the tip of the screw to be free of hole A in the lock plate.
6. Use the screwdriver to rotate the locking lever to its unlocked position (hole B—see figure 4-4). Tighten the screw to secure the locking lever in hole B.
7. Close the head lock access plate and reinstall the two screws removed in step 3.
8. Push the disk drive back into the enclosure, and resecure it to the brackets on the rear RETMA rail.
9. Reconnect the command and data cables to the disk drive at the three connectors labeled SMD COMMAND, IN, and DATA A as shown in figure 4-1.

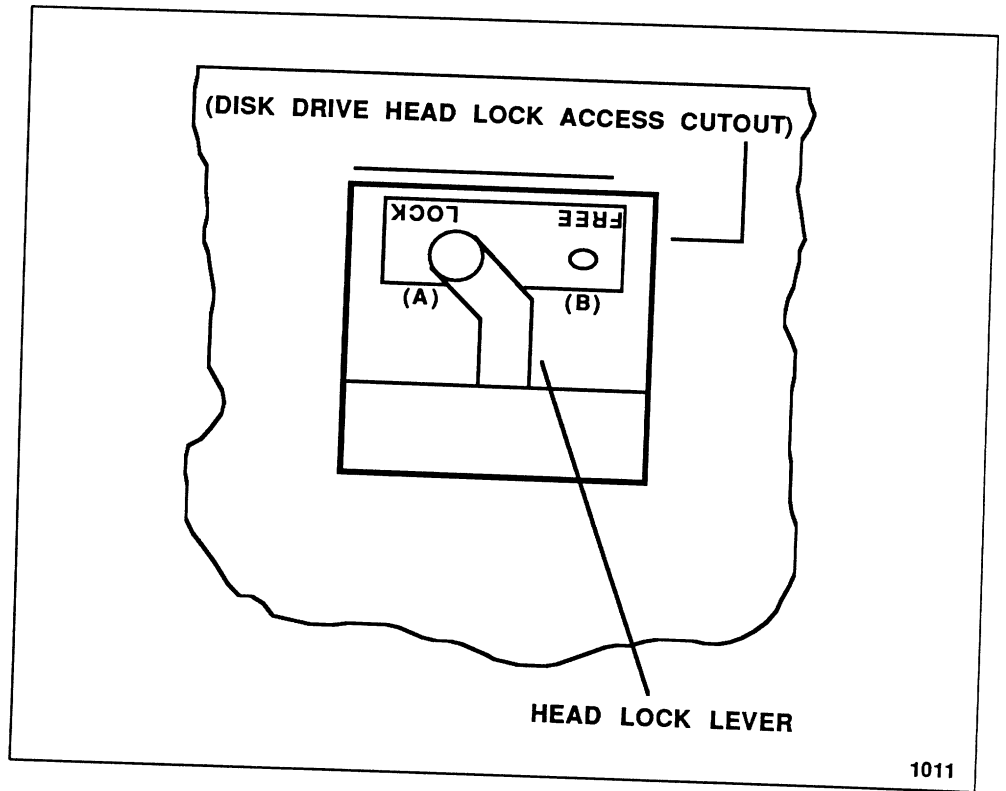

Figure 4-4 *Location of the Disk Drive Head-Lock Lever*



---

## Line Power Connection

Line Power Connection .....	25
5.1. Safety Precautions .....	25
5.2. Connection Procedure .....	26
5.3. Power Requirements .....	27

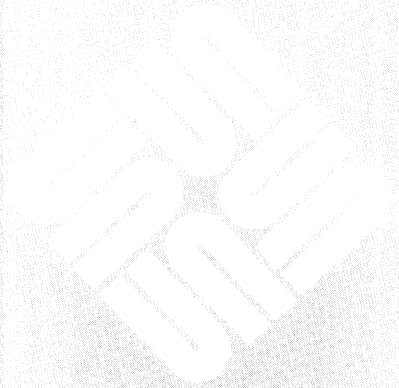





---

## Line Power Connection

### 5.1. Safety Precautions

**CAUTION** Do not make mechanical or electrical modifications to the rack systems. Sun will no longer be responsible for regulatory compliance of modified racks.

All power cords for components in the rack must be plugged into the power controller. They may not be routed outside the rack. Additional power controllers may not be added to the rack.

The rack system has high leakage current to ground. The following instructions must be strictly observed in order to reduce the risk of electric shock.

1. The following plug types are provided on the power cord:
  - a. NEMA L5-30P for 100-120V North American operation.
  - b. NEMA L6-30P for 200-240V North American operation.
  - c. 32A, single phase, IEC 309 connector for 220-240V European operation.

If an appropriate mating receptacle is not available in your country, the plug may be removed from the cord. The cord may then be permanently connected to a dedicated branch circuit by a qualified electrician. Check local electrical codes for proper installation.

2. An insulated grounding conductor that is identical in size, insulation material, and thickness to the grounded and ungrounded branch-circuit supply conductors, except that it is green with or without one or more yellow stripes, is to be installed as part of the circuit that supplies the unit or system.
3. The grounding conductor described in item 2 above is to be grounded to earth at the service equipment, or, if supplied by a separately derived system, at the supply transformer or motor-generator set.
4. The attachment-plug receptacles in the vicinity of the unit are all to be of grounding type, and the grounding conductors serving these receptacles are to be connected to earth ground at the service equipment.

**5.2. Connection Procedure**

Perform the procedure in the following paragraphs to connect the system to AC line power.

1. Turn the keyswitch, located at the front of the rack, to the vertical (OFF) position.

*NOTE* The keys for this switch will either be packed in the base box or attached to this manual.

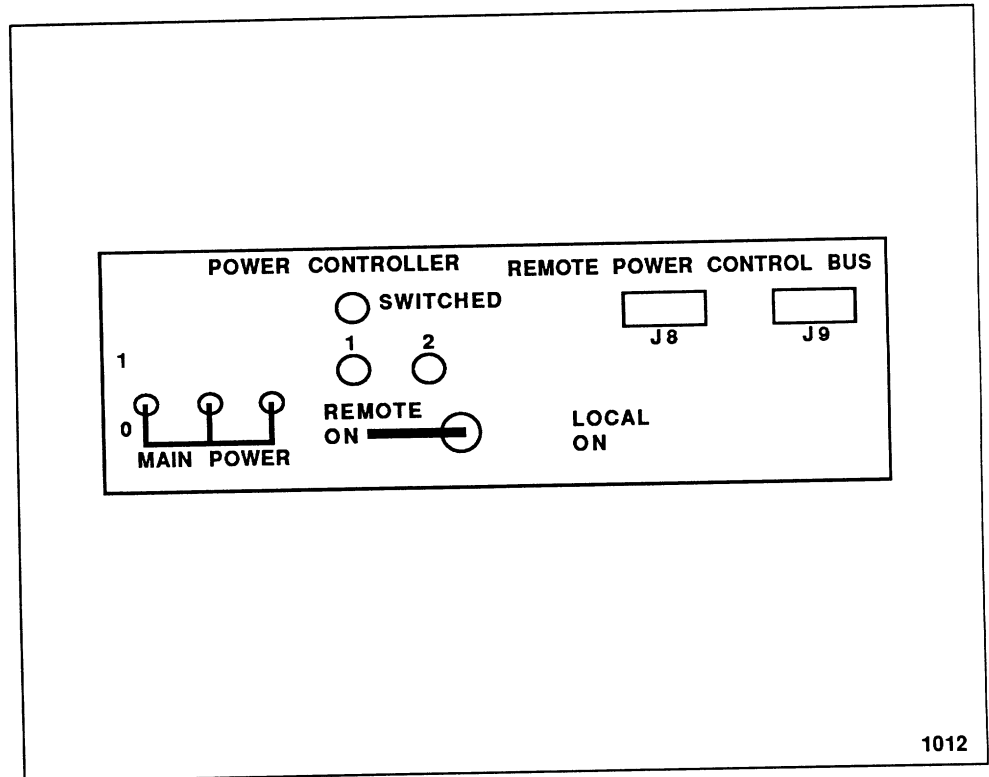

Figure 5-1 *Power Controller Control Panel*

2. Set the power controller LOCAL/REMOTE switch to the REMOTE ON position. Then, switch on the MAIN POWER circuit breaker.
3. Turn the keyswitch, located at the front of the rack, to the horizontal (ON) position. If you do not hear the fans spinning, turn off the keyswitch and investigate the cause.
4. The Sun Full-height Rack system is now powered up.

**5.3. Power Requirements**

The following table gives maximum operating voltage and frequency ranges.

Configuration*	Nominal AC Input Voltage Range	Operating Voltage Range	Operating Frequency Range
Domestic	100-120 VAC	90-132 VAC	47-63 Hz
Domestic (V3 Option)	200-240 VAC	180-264 VAC	47-63 Hz
European (V4 Option)	220-240 VAC	180-264 VAC	47-63 Hz

The following table shows the current requirements at nominal line voltage for a rack in maximum configuration.

Configuration*	Nominal AC Input Voltage Range	Maximum Current Requirement	Maximum Current per Controller Outlet
Domestic	100-120 VAC	24 A	12 A
Domestic (V3 Option)	200-240 VAC	24 A	12 A
European (V4 Option)	220-240 VAC	24 A	6 A

\* Racks configured for domestic (US) operation also are suitable for use in Canada, Japan, Korea, and Taiwan. All other areas should use racks configured for European operation.



---

## Power Controller

Power Controller .....	31
6.1. Controller Operation .....	31

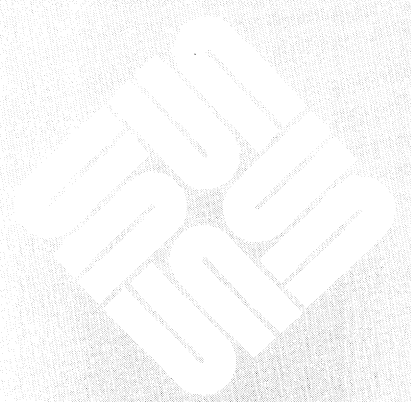



## Power Controller

### 6.1. Controller Operation

In order to reduce the power-up load on the AC line, a *power controller* has been designed into the Sun Full-height Rack. The controller does a couple of things:

- powers the components up in a controlled sequence (Four-second delay between switched 1 and switched 2 for 100-120V racks. Twenty-second delay for "V3" and "V4" rack options between switched 1 and switched 2.), and
- provides noise and transient protection.

The following figures show the correct arrangement of equipment connections to the power controllers for system racks. Expansion rack equipment connections should be split evenly between switched 1 and switched 2.

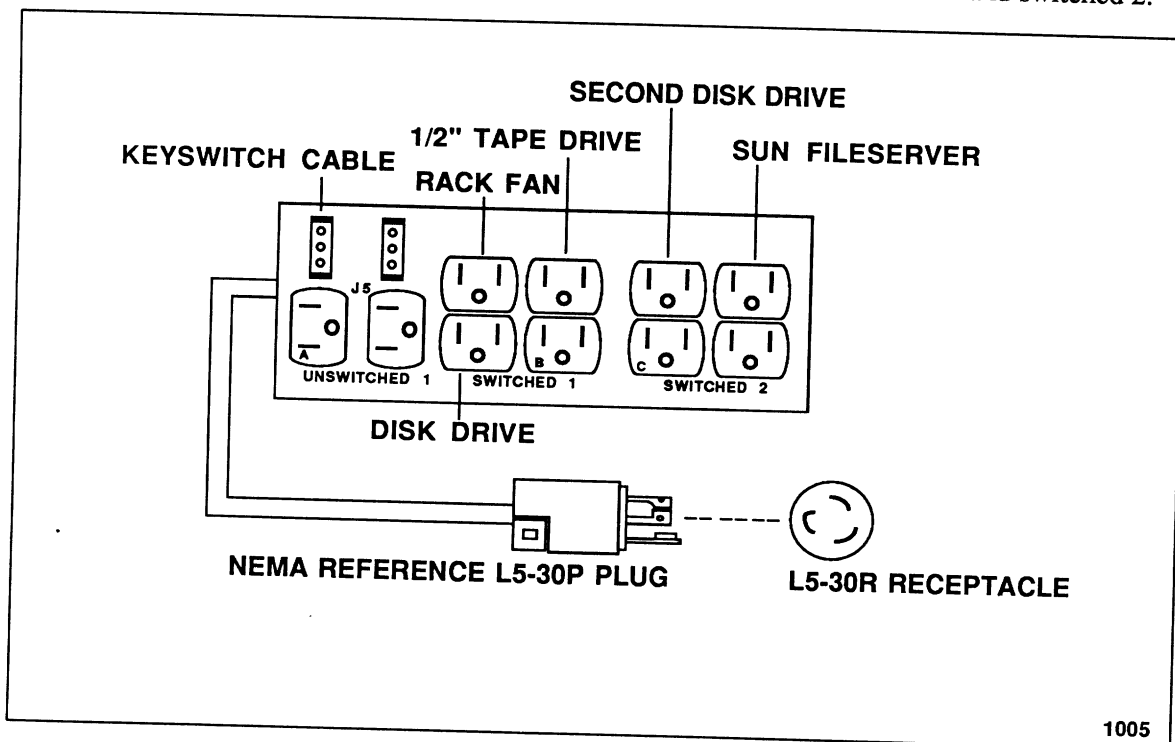

Figure 6-1 Connections to the 100-120V Domestic Power Controller



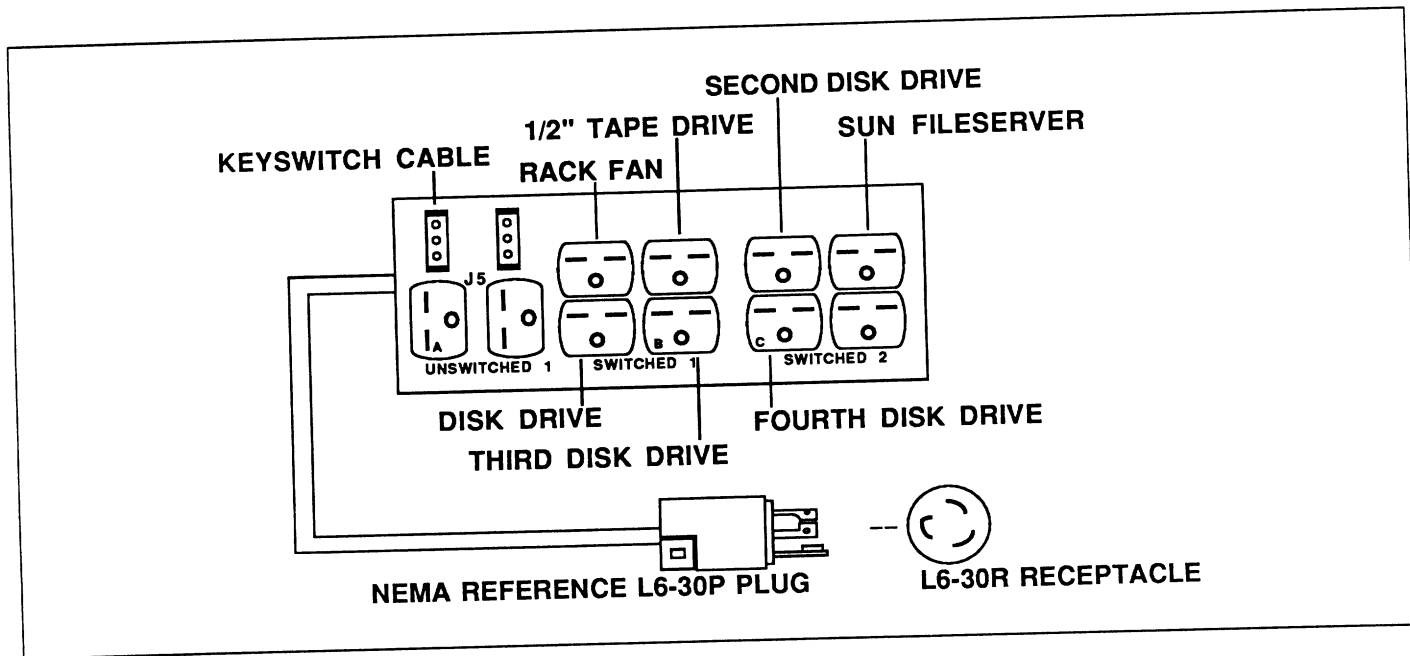

Figure 6-2 Connections to the 200-240V Domestic Power Controller

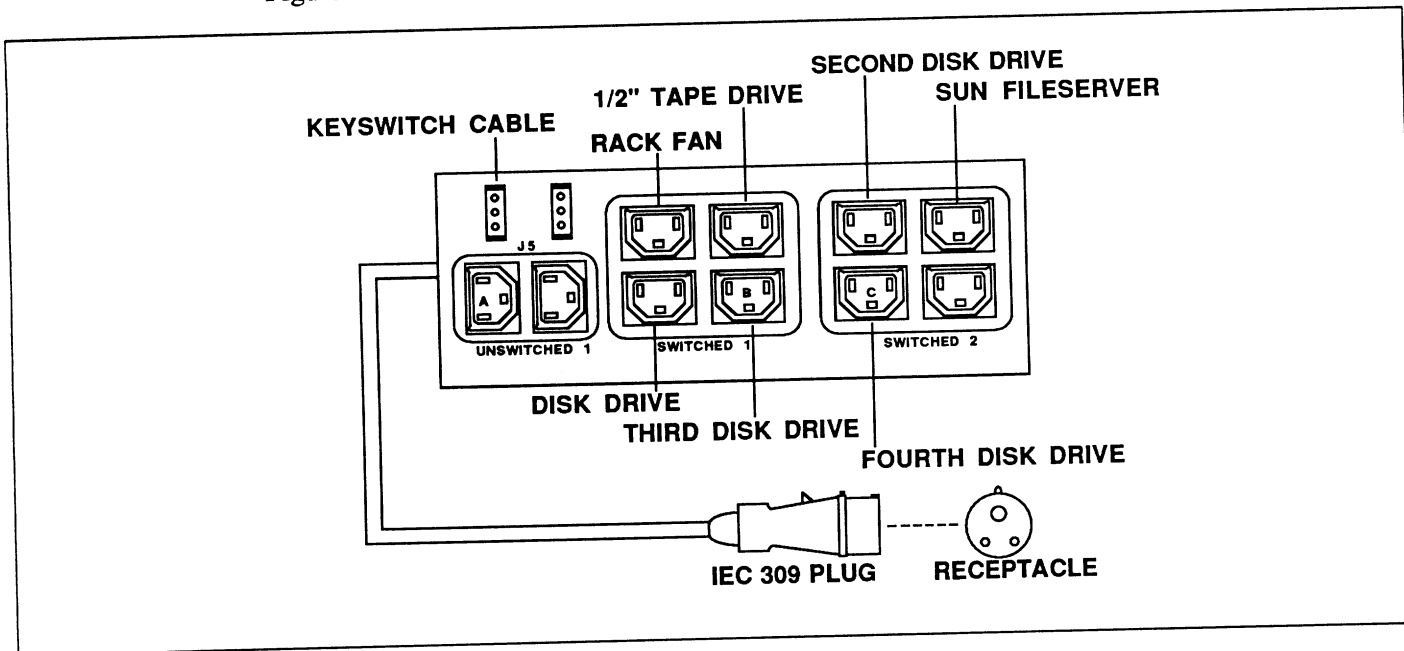
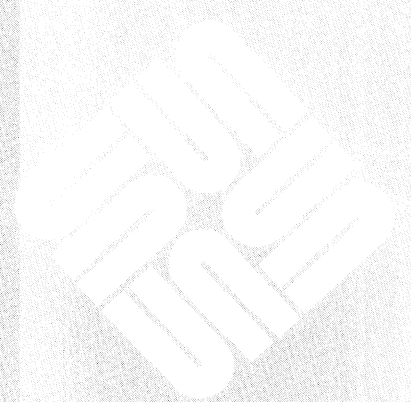

Figure 6-3 Connections to the 220-240V European Power Controller

---

## Cable Routing and Cooling

Cable Routing and Cooling .....	35
7.1. RF Emission .....	35
7.2. Cooling and Airflow .....	35
7.3. After the Installation is Complete .....	35



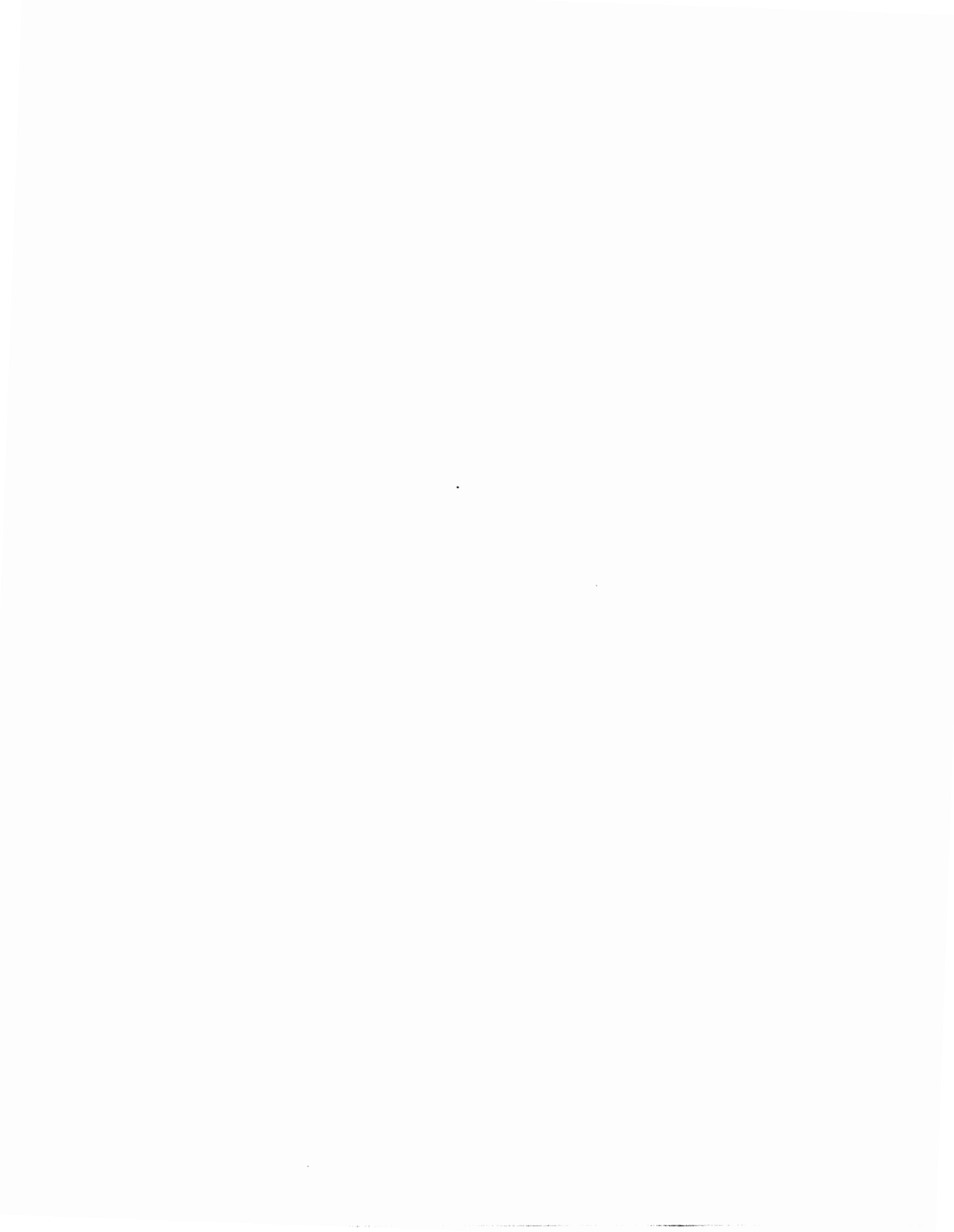

---

## Cable Routing and Cooling

### 7.1. RF Emission

The enclosure has been designed to control RFI emissions. Any operation of the system with panels removed or doors left open will void FCC qualification of the system. Keyboard, mouse, and monitor (whether black and white, color or grayscale) connections to the system are made through a cable hatch. Cables routed in or out of the enclosure are routed through the cable hatch.

Keyboard, monitor, and remote terminal connections, along with other information specific to the CPU board ordered with your system is included in the board installation document shipped with your rack unit.

### 7.2. Cooling and Airflow

The Sun Rack enclosure is equipped with an exhaust fan mounted at the top of the rack for internal air circulation. This fan is connected to the power controller and turns on when the keyswitch is rotated to position "1."

Cooling air flows from the bottom of the rack enclosure, across the disk drive, vertically past the half-inch tape drive, to exhaust at the top of the system. Internal blowers provide air circulation for the individual equipment units.

#### CAUTION

**Do not place anything on top of the enclosure which would restrict this air flow.**

### 7.3. After the Installation is Complete

This completes the mechanical portion of the installation. The system is now ready for software installation; refer to *Installing UNIX on the Sun Workstation*, or *Installing SunOS on the Sun Workstation*, for further instructions.



**Corporate Headquarters**  
Sun Microsystems, Inc.  
2550 Garcia Avenue  
Mountain View, CA 94043  
415 960-1300  
TLX 37-29639  
**For U.S. Sales Office**  
**locations, call:**  
800 821-4643  
In CA: 800 821-4642

**European Headquarters**  
Sun Microsystems Europe, Inc.  
Sun House  
31-41 Pembroke Broadway  
Camberley  
Surrey GU15 3XD  
England  
0276 62111  
TLX 859017

**Australia:** (02) 436 4699  
**Canada:** 416 477-6745  
**France:** (1) 46 30 23 24  
**Germany:** (089) 95094-0  
**Japan:** (03) 221-7021  
**Nordic Countries:** (08) 764 78 10  
**Switzerland:** (1) 82 89 555  
**The Netherlands:** 02155 24888  
**UK:** 0276 62111

**Europe, Middle East, and Africa,**  
**call European Headquarters:**  
0276 62111

**Elsewhere in the world,**  
**call Corporate Headquarters:**  
415 960-1300  
Intercontinental Sales

