



TZ88 20/40 GB DLT Cartridge Tape Drive

- StorageWorks Building Block (SWXTL-CA)
- Tabletop Tape Drive (SWXTL-CT)

User's Guide

EK-SM1TF-UG. A01

Digital Equipment Corporation
Maynard, Massachusetts

First Edition, December 1995

The information in this document is subject to change without notice and should not be construed as a commitment by Digital Equipment Corporation. Digital Equipment Corporation assumes no responsibility for any errors that may appear in this document.

Restricted Rights: Use, duplication, or disclosure by the U.S. Government is subject to restrictions as set forth in subparagraph (c) (1) (ii) of the Rights in Technical Data and Computer Software clause at DFARS 252.227-7013.

Digital Equipment Corporation does not give a warranty of any kind regarding the fitness or applicability of the information content for a particular purpose. The user assumes all responsibility for understanding the interrelationships of this enclosed information with other affected software or system products.

The disclosure of this information does not grant to the user a license under any patents, pending patents, trademarks, or copyrights or other rights of Digital Equipment Corporation, or of any third party.

FCC Notice: This equipment has been tested and found to comply with the limits for a Class B digital device, pursuant to Part 15 of the FCC rules. These limits are designed to provide reasonable protection against harmful interference in a residential installation. Any changes or modifications made to this equipment may void the user's authority to operate this equipment. The shielded interconnect cable, as supplied with the unit, may not be substituted, nor altered or modified, in any way.

This equipment generates, uses, and can emit radio frequency energy and, if not installed and used in accordance with the instructions, may cause harmful interferences to radio communications. However, there is no guarantee that interference will not occur in a particular installation. If this equipment does cause harmful interference to radio or television reception, which can be determined by turning the equipment off and on, the user is encouraged to try to correct the interference by one or more of the following measures:

- Reorient or relocate the receiving antenna.
- Increase the separation between the equipment and receiver.
- Connect the equipment into an outlet on a circuit different from that to which the receiver is connected.
- Consult your reseller or an experienced radio/TV technician for help.

Copyright © Digital Equipment Corporation 1995
All Rights Reserved
Printed in U. S. A

The following are trademarks of Digital Equipment Corporation:

DEC Digital StorageWorks

VMS TZ88 and the Digital Logo:

AIX™ and IBM™ are trademarks of International Business Machines, Inc.

HP™ is a registered trademark of Hewlett-Packard Corporation.

Intel™ is a registered trademark of Intel Corporation.

NetWare™ and Novell™ are trademarks of NOVELL, Inc.

Sun™, SunOS™, and Solaris™ are trademarks of Sun Microsystems, Inc.

WINDOWS NT™ and MS-DOS™ are trademarks of Microsoft Corporation.

All other trademarks and registered trademarks used in this publication are the property of their respective owners

Contents

1 Introduction

1.1	Product Overview	1-1
1.2	Design Features	1-1
1.2.1	Basic Components	1-1
1.2.2	Performance Considerations.....	1-1
1.3	Data Tape.....	1-2
1.3.1	CompacTape IVdescription.....	1-2
1.3.2	Cartridge Packaging.....	1-3
1.4	Reading and Writing Data.....	1-3
1.4.1	Write-Protecting Data	1-3
1.5	Head Cleaning Tape	1-4
1.5.1	CleaningTape III Description.....	1-4
1.5.2	CleaningTape III Packaging.....	1-4
1.5.3	CleaningTape III Cartridge Expiration	1-4
1.6	Supplies.....	1-5
1.6.1	Cartridges Provided	1-5
1.6.2	How To Order Replacement Cartridges.....	1-5

2 Installation and Operation of the SWXTL-CA Tape Drive in a Storage Subsystem

2.1	Introduction.....	2-1
2.2	Unpacking.....	2-1
2.3	Preinstallation Procedures	2-2
2.3.1	Setting the SCSI ID Address of the Tape Drive.....	2-2
2.4	Installing the SWXTL-CA SBB Tape Drive Into a StorageWorks Expansion Storage Subsystem.....	2-3
2.5	Power On Self Test (POST).....	2-4

3 Installation and Operation of the SWXTL-BT Tabletop Tape Drive

3.1	Introduction.....	3-1
3.2	Unpacking.....	3-1
3.3	Preinstallation Procedures	3-2
3.3.1	Setting the SCSI ID Address of the Tape Drive.....	3-2
3.4	Installation of SWXTL-CT Tabletop DLT Tape Drive	3-4
3.4.1	SWXTL-CT Power On Self Test (POST).....	3-4

4 Controls, Indicators, and Operation

4.1	General	4-1
4.2	Front-Panel Controls and Indicators	4-1
4.2.1	Unload Push-Button	4-2
4.2.2	Cartridge Insert/Release Handle	4-2
4.2.3	DENSITY SELECT Switch	4-3
4.3	Power-On Self-Test (POST)	4-4
4.4	Status Indication of Tape Drive LEDs	4-6
4.5	CompacType IV DLT Tape Cassette	4-7
4.5.1	Write-Protect Switch	4-8
4.5.2	Data Protection	4-8
4.5.3	Loading A Cartridge	4-9
4.5.4	Tape in Use	4-11
4.5.5	Unloading A Cartridge	4-11
4.5.6	Using the Tape Cleaning Cartridge	4-12
4.5.7	Preserving Cartridges	4-12
4.6	Selecting Density	4-13
4.6.1	How To Select Density At The Front Panel	4-14
4.6.1.1	Selection of Compression Mode	4-14
4.6.1.2	Density Select Example	4-15
4.6.2	Density Selection Rules	4-15

5 Maintenance

5.1	Introduction	5-1
5.2	Common Errors	5-1
5.2.1	Avoiding Basic Problems	5-1
5.2.2	Error Influences	5-1
5.3	Cleaning the Heads	5-2
5.4	Inspections	5-3
5.4.1	Checking the Cartridge Leader	5-3
5.4.2	Checking the Drive Leader	5-3
5.5	Troubleshooting	5-6

Appendix A Specifications

Appendix B Product Notes for Novell and MS-DOS

B.1	Host SCSI Interface	B-1
-----	---------------------------	-----

Appendix C Product Notes for Sun™

C.1	General Information	C-1
C.2	Modifications Required for SunOS 4.1.x	C-1
C.2.1	Installation Procedure	C-1
C.2.1.1	System Modification	C-1
C.2.1.2	Rebuilding of Kernel	C-3
C.2.1.3	Installation of Tape Drive	C-3
C.2.1.4	Rebooting of System	C-3
C.2.1.5	Testing the TZ88 Model 20/40 GB DLT SBB	C-4

C.2.1.6	Verification	C-4
C.2.2	Dump Parameters for the Tape Drive	C-4
C.3	Modifications Required for Solaris™ 2.3 (or later)	C-5
C.3.1	Installation Procedure	C-5
C.3.1.1	System Modification	C-5
C.3.1.2	System Shutdown	C-6
C.3.1.3	Installation of Tape Drive.....	C-6
C.3.1.4	Rebooting of System	C-7
C.3.1.5	Test	C-8
C.3.1.6	Verification	C-8
C.3.2	Running SUN Diagnostics (Optional)	C-8
C.3.3	Dump Parameters for the Tape Drive	C-8

Appendix D Product Notes for IBM™ RS/6000

D.1	Modifications Required to Operate the SWXTL-BA with AIX 3.2.5 (or later)	D-1
D.1.1	Installing the SWXTL-BA Using the SMIT Command	D-1
D.1.2	Installing the SWXTL-BA Using Command-Line Interface	D-2

Appendix E Product Notes for Hewlett Packard

E.1	General Information	E-1
E.2	Modifications Required	E-1
E.2.1	Installation Procedure	E-1
E.2.1.1	Installation of Tape Drive.....	E-1
E.2.1.2	System Modification	E-1
E.3	Series 700 System Device Files.....	E-2
E.3.1	HP-UX 9.05.....	E-2
E.3.2	HP-UX 10.00.....	E-3
E.4	Series 800 System Device Files.....	E-4
E.4.1	HP-UX 9.05.....	E-4
E.4.2	HP-UX 10.00.....	E-5
E.5	Testing the Tape Drive.....	E-6
E.5.1	Verification	E-6
E.6	Dump Parameters for the Tape Drive	E-6

Figures

1-1	Front Panel of TZ88 Model 20/40-GB DLT Cartridge Tape Drive.....	1-2
1-2	CompacTape IV Cartridge	1-3
1-3	CompacTape III Cleaning Tape	1-4
2-1	SWXTL-CA Tape Drive SCSI ID Switches	2-2
2-2	Installing the SWXTL-CA into an Expansion Storage Pedestal.....	2-4
2-3	Tape Drive Front Panel Controls and Indicators.....	2-5
3-1	SWXTL-CT Tape Drive Front Panel Controls and Indicators	3-4
4-1	Front Panel Layout of 10/20-GB DLT Cartridge Tape Drive.....	4-2
4-2	CompacTape IV Data Tape Cartridge	4-9
4-3	Loading Cartridge Into Tape Drive	4-10
4-4	Unloading Cartridge From Tape Drive.....	4-12
5-1	Checking Out Cartridge Leader	5-4
5-2	Correct Engagement of Take-Up Leader in Tape Drive	5-4
5-3	Correct and Incorrect Positions of Tape Drive Leader.....	5-5

Tables

1-1	Ordering Numbers for Cleaning Tape and Data Tapes	1-5
2-1	SWXTL-BA Tape Drive SCSI ID Switch Settings	2-3
3-1	10/20-GB DLT Cartridge Tape Drive SCSI Interface Cables	3-2
4-1	Right-side Front Panel Indicators and Controls	4-3
4-2	Left-side Front Panel Indicators and Controls	4-4
4-3	Operating States of 10/20-GB DLT Cartridge Tape Drive Unit Following Initialization.....	4-6
4-4	Tape Drive LED Status	4-7
4-5	Moving Write-Protect switch Before Tape Drive Operation.....	4-9
4-6	Moving Write-Protect switch During A Read/Write Operation	4-9
4-7	What is Happening During Cartridge Use (Right-Side Indicators).....	4-10
4-8	When To Use the Cleaning Cartridge.....	4-12
4-9	Density Selections Available On 10/20-GB DLT Cartridge Tape Drive	4-13
4-10	Results of Density Selection	4-16
5-1	Possible Corrections for Common Error Situations	5-2
5-2	Troubleshooting Table	5-6
A-1	10/20-GB DLT Cartridge Tape Drive Specifications.....	A-1
C-1	Density Codes for Sun and Solaris	C-3

Revision Record

This Revision Record provides a concise publication history of this guide. It lists the manual revision levels, release dates, and reasons for the revisions. It also describes how the changes to affected pages are marked in the guide.

The following revision history lists all revisions of this publication and their effective dates. The publication part number is included in the *Revision Level* column, with the last entry denoting the latest revision. This publication supports the StorageWorks SWXTL-BA SBB and SWXTL-BT Tabletop Cartridge Tape Drives.

Revision Level	Date	Summary of Changes
EK-SM1TF-UG. A01	December 1995	Original release

About This Guide

This section identifies the users of this guide and describes the contents and structure. In addition, it includes a list of conventions used in this guide.

This guide provides a product overview, installation, operation, and maintenance information for the StorageWorks SWXTL-CA SBB and/or SWXTL-CT Tabletop DLT Cartridge Tape Subsystems, both of which contain a TZ88 Model 20/40 GB DLT Cartridge Tape Drive.

Intended Audience

This guide is intended for people who will install, operate, and maintain the StorageWorks SWXTL-CA SBB and/or SWXTL-CT Tabletop DLT Cartridge Tape Subsystems.

Document Structure

This guide contains the following chapters:

Chapter 1. Introduction

Chapter 1 gives an overview of the TZ88 Model 20/40-GB DLT Cartridge Tape Drive, describes its components, and discusses the drive features. This chapter provides a product overview of the 20/40-GB DLT Cartridge Tape Drive and identifies design features (including basic components and performance considerations). The chapter also includes overview descriptions of the data tape and cleaning tape cartridges used with this equipment, defining the basic functions of each, and identifies what is supplied with the tape drive unit.

Chapter 2. Installation and Operation of the SWXTL-CA SBB Tape Drive in a Storage Subsystem

Chapter 2 provides specific details pertaining to the SWXTL-CA SBB Tape Drive, which is designed to be operated in a Digital StorageWorks Expansion Storage subsystem. This chapter describes how to unpack the received drive, how to prepare the drive for installation in the subsystem, how to set the SCSI ID of the tape drive, how to install the device into a StorageWorks expansion storage subsystem, and how to confirm operation integrity by performing the Power On Self Test (POST) exercise.

Chapter 3. Installation and Operation of the SWXTL-BT Tabletop Tape Drive

Chapter 3 provides specific details pertaining to the SWXTL-CT SBB Tape Drive, which is designed to be operated as an independent standalone unit on the desktop, a convenient shelf, or other flat surface. This chapter describes how to unpack the received SWXTL-BT tabletop drive, how to prepare the drive for installation, how to set the SCSI ID of the tape drive, how to perform the Power On Self Test (POST) procedure, and how to connect the tape drive to a host computer.

Chapter 4. Controls, Indicators, and Operation,

Chapter 4 describes the tape drive's LED indicators and how to use them to monitor tape drive operation. This chapter identifies the switches and LED indicators on the front panel of the TZ88 Model 20/40-GB tape drive, describes how to use them (including operation of the power-on self-test (POST)), provides use rules for the CompacTape IV DLT cartridge data and cleaning tapes, gives detailed procedures for correct loading and unloading of the tape cartridges, and explains how to select a desired density format for recording.

Chapter 5. Maintenance

Chapter 5 describes how to clean the heads of the tape drive, and provides a troubleshooting table to help diagnose common problems. This chapter describes preventive maintenance and general troubleshooting for the TZ88 Model 20/40-GB DLT Cartridge Tape Drive.

Appendix A. Specifications

Appendix A lists the physical, electrical, cooling, environmental, and environmental stabilization specifications for the tape drive.

Appendix B. Product Notes for Novell™ and MS-DOS™

Appendix B provides information for the system administrator about interfacing the TZ88 20/40-GB DLT Cartridge Tape Drive with a host system operating under the Novell, MS-DOS, or MS/DOS/WINDOWS operating systems.

Appendix C. Product Notes for Sun™ SunOS 4.1.x and Solaris™ 2.3 Systems

Appendix C provides information for the system administrator about interfacing the TZ88 20/40-GB DLT Cartridge Tape Drive with a Sun SPARC system running SunOS 4.1.x or Solaris 2.3 (or later). The information covers the installation of the tape drive hardware and configuring the system to communicate with the drive.

Appendix D. Product Notes for IBM™ AIX™ 3.2.5 (or later) Systems

Appendix D provides information for the system administrator about interfacing the TZ88 20/40-GB DLT Cartridge Tape Drive with an IBM™ RS/6000 system running AIX™ 3.2.5 (or later). The information covers the installation of the SWXTL tape drive hardware and configuring the system to communicate with the drive.

Appendix E Product Notes for Hewlett-Packard

Appendix E provides information for the system administrator about interfacing the TZ88 20/40-GB DLT Cartridge Tape Drive with an HP 9000 Series 700 system running HP-UX 9.05 (or later) or an HP 9000 Series 800 system running HP-UX 9.04 (or later). The information covers the installation of the tape drive hardware and configuring the system to communicate with the drive.

Conventions

This guide uses the following conventions:

Style	Meaning
boldface type	For emphasis
<i>italic type</i>	<i>For emphasis and manual titles</i>

Novell™ is a trademarks of Novell.

MS-DOS™ is a trademark of Micosoft Corporation

SunOS™ and Solaris™ are trademarks of Sun Microsystems, Inc.

IBM™ and AIX™ are tradaemarks of IBM Inc.

Introduction

This chapter provides a product overview of the TZ88 Model 20/40 GB DLT Cartridge Tape Drive and identifies design features (including basic components and performance considerations). The chapter also includes overview descriptions of the data and cleaning tape cartridges, defining the basic functions of each, and identifies what is supplied with the tape drive.

1.1 Product Overview

The StorageWorks TZ88 Model 20/40 GB DLT Cartridge Tape Drive is a streaming tape drive which connects to a SCSI bus. Assuming a 2:1 compression ratio on a CompacTape IV cartridge, this device can store up to 40 GB of data with compression, or up to 20.0 GB of data without compression. The primary uses for this drive are data backup, data archiving, and loading software onto computer systems. The TZ88 Model 20/40 GB DLT Cartridge Tape Drive comes either embedded in a system enclosure, in which case it is identified as an SWXTL-CA StorageWorks Building Block (SBB), or else in an enclosure with a self-contained power supply, in which case it is identified as an SWXTL-CT Tabletop Tape Drive. This initial section of this document discusses the generic information that is common to either version; subsequent sections will provide details that are specific to either product.

1.2 Design Features

Figure 1–1 shows a view of the front panel, which provides status indicators for system operation, along with an access door for inserting and removing the CompacTape IV tape cartridge.

1.2.1 Basic Components

The TZ88 Model 20/40 GB DLT Cartridge Tape Drive has an integrated SCSI controller module that connects to the host computer system's SCSI adapter. The controller module is responsible for processing SCSI commands and for initiating tape drive operations. In the case of the SBB the connection to the SCSI bus is made through the StorageWorks Expansion Storage Pedestal, as discussed in Chapter 2. For the Tabletop device, the connection to the SCSI bus must be made through an appropriate cable, depending on the type of host adapter that is used and/or the desired physical length of cable (See Chapter 3).

1.2.2 Performance Considerations

The performance you can achieve with the TZ88 Model 20/40 GB DLT Cartridge Tape Drive can depend on a number of considerations, including your system processor. When set to compressed mode, this tape drive theoretically can back up 10.8 GB of data per hour (tape streaming at maximum speed and recording highly compressible data). In a host-based

configuration, proper choice of system processor, cache, hard drive, adapters, and backup software can help to approach this throughput rate. Host SCSI IO or other computer-intensive operations on the host CPU reduces throughput to tape.

Figure 1–1 Front Panel of TZ88 Model 20/40 GB DLT Cartridge Tape Drive

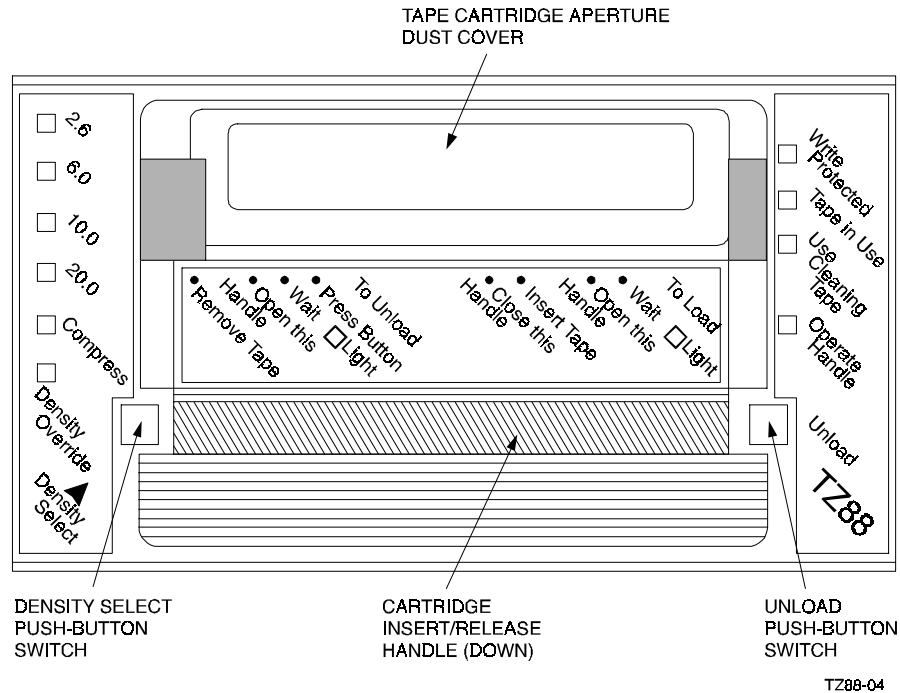

When data is being passed from or to client workstations in a client-server environment, additional parameters having to do with reduced local area network bandwidth, network traffic, or lower client workstation performance characteristics will also tend to reduce maximum throughput to the tape drive.

1.3 Data Tapes

1.3.1 CompacTape IV Description

The CompacTape IV cartridge is a 4-1/8-inch square, black, plastic cartridge, containing 1800 (1778 usable) feet of 1/2-inch magnetic, metal particle (MP) tape. A write-protect slide switch on the front surface lets you select between two positions: write enabled (switch moved to the right), which lets the tape drive write data on the tape, and write protected (switch moved to the left), which prevents the tape drive from writing over data you want to preserve (See Figure 1–2).

NOTE

CompacTape III and IIIXT tape cartridges can also be used with the TZ88 Model 20/40 GB Cartridge Tape Drive. The CompacTape III cartridge contains 1167 (usable) feet of 1/2-inch magnetic tape and has a storage capacity of 10 GB uncompressed and 20 GB compressed. The CompacTape IIIXT cartridge has a white plastic case, contains 1778 (usable) feet of 1/2-inch magnetic tape and has a storage capacity of 15 GB uncompressed and 30 GB compressed.

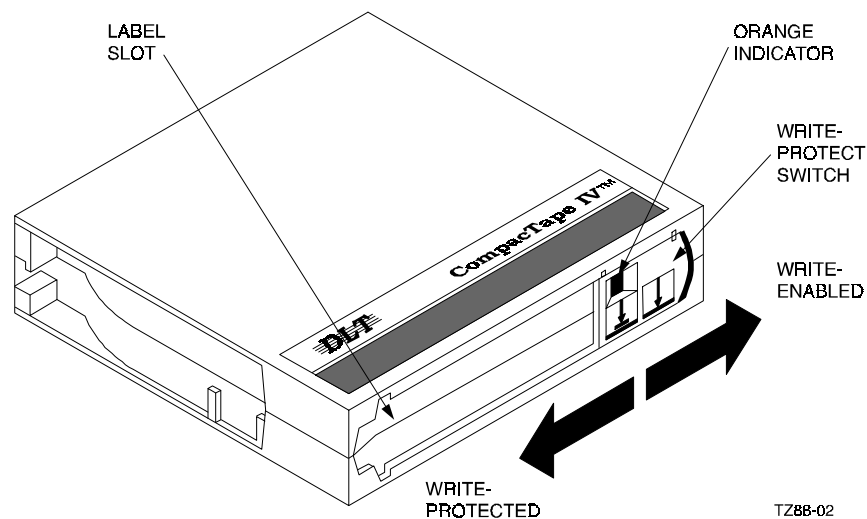
Figure 1–2 CompacTape IV Data Cartridge**1.3.2 Cartridge Packaging**

Your CompacTape IV cartridge comes supplied with:

1. A set of slide-in labels
2. A cartridge-handling information sheet

1.4 Reading and Writing Data

The TZ88 Model 20/40 GB DLT Cartridge Tape Drive writes 64 pairs of tracks — 128 tracks total — on the CompacTape IV tape. The drive reads and writes data in a two-track parallel, serpentine fashion, traveling the entire length of tape on two tracks. The drive then steps the head, reverses tape direction, and continues to read/write on the next two tracks, repeating this same process for a total of 64 times per tape.

1.4.1 Write-Protecting Data

The CompacTape IV cartridge has a write-protect slide-bar switch on its front surface that prevents accidental erasure of data. When you move the switch to the left, so that a small orange rectangle is visible in the aperture over the left arrow symbol on the switch (see Figure 1–2), the tape is write-protected and data cannot be written to the tape. When you

move the switch to the right, so that no orange color shows in the rectangular aperture, the tape is write-enabled, and the tape drive can write to the tape. The symbols on the slide-bar switch indicate this function by depicting data flow as a downward-pointing arrow and the tape medium as a horizontal line below the arrow's point. The arrow on the left side of the slide-bar switch depicts a barrier line between the data-flow arrow and the tape; this symbolizes that the data cannot reach the tape when the switch is moved to the left. No such barrier line appears below the arrow on the right side of the switch, indicating that data can flow to the tape when the switch is moved to the right.

1.5 Head Cleaning Tape

Head cleaning tape is used to maintain the cleanliness of the read/write heads in the tape drive. Accumulation of dirt on the heads can cause read and/or write errors. The head cleaning tape should be used periodically, the length of the period depending on use of the drive.

1.5.1 CleaningTape III Description

The CleaningTape III cartridge is a 4-1/8-inch square, light yellow, plastic cartridge containing 1200 feet of 1/2-inch cleaning tape (see Figure 1-3). For information on using the CleaningTape III cartridge, refer to Table 4-8.

Figure 1-3 Cleaning Tape

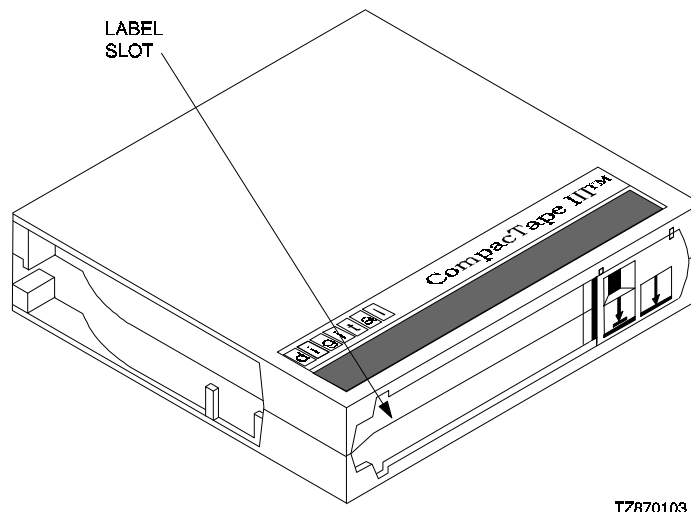

1.5.2 CleaningTape III Packaging

The CleaningTape III cartridge comes supplied with:

1. A slide-in label containing 20 boxes, one box to be checked off following each sequential use of the CleaningTape III cartridge (refer to Section 1.5.3).
2. A cartridge-handling information sheet.

1.5.3 CleaningTape III Cartridge Expiration

Each use of the CleaningTape III cartridge uses up some of the cleaning area on the tape. You can use the CleaningTape III cartridge approximately 20 times before the cleaning area is used up. After that many uses, the cartridge will be ineffective and should be replaced with a new cartridge.

To keep track of the number of times the tape has been used, place a check mark in one of the 20 boxes on the cartridge label after each cleaning.

1.6 Supplies

1.6.1 Cartridges Provided

One CompacTape IV cartridge and one CleaningTape III cartridge come with each TZ88 Model 20/40 GB DLT Cartridge Tape Drive, in the shipping package.

1.6.2 How To Order Replacement Cartridges

You can order additional cartridges by contacting your Digital reseller or by calling Digital's DECdirect ordering service at 1-800-DIGITAL in the U.S.A.; in Canada, call 800-267-6215.

Table 1–1 lists ordering numbers for various quantities of cartridges for the TZ88 Model 20/40 GB DLT Cartridge Tape Drives:

Table 1–1 Ordering Numbers for Data Tapes and Cleaning Tape

CompacTape IV Tapes	
Order Number	Description
TK88K-01	CompacTape IV Data Cartridge (quantity, 1)
TK88K-07	CompacTape IV Data Cartridge (quantity, 7)
TK88K-A1	CompacTape IV Data Cartridge (quantity, 945)
CompacTape III Tapes	
Order Number	Description
TK85-HC	CleaningTape III Head Cleaning Cartridge
TK85K-01	CompacTape III Data Cartridge (quantity, 1)
TK85X-01	CompacTape IIIXT Data Cartridge (quantity, 1)
TK85K-07	CompacTape III Data Cartridge (quantity, 7)
TK85K-A1	CompacTape III Data Cartridge (quantity, 945)

Installation and Operation of the SWXTL-CA Tape Drive in a Storage Subsystem

This chapter provides specific details pertaining to unpacking, preinstallation setup, installation, and POST operational testing of the SWXTL-CA StorageWorks Building Block (SBB) Tape Drive, which is designed to be operated in a Digital StorageWorks Expansion Storage Pedestal.

2.1 Introduction

The SWXTL-CA Tape Drive is housed in an SBB storage carrier and is designed for installation into a StorageWorks Storage Expansion Pedestal subsystem. The drive occupies three adjacent slots in the storage enclosure and is configured as one of up to seven devices on the SCSI bus. This chapter describes how to unpack the drive, how to prepare the drive for installation, how to set the SCSI ID of the tape drive, how to install the device into a StorageWorks Expansion Storage Pedestal subsystem, and how to perform the Power-On Self-Test (POST) procedure.

2.2 Unpacking

Unpack and inspect the contents of your shipment. It should contain the following items:

- This guide
- One TZ88 Model 20/40 GB DLT Cartridge Tape Drive
- One blank CompacTape IV data cassette tape cartridge
- One CleaningTape III head-cleaning cartridge
- One StorageWorks *TZ88 Model 20/40 GB DLT Cartridge Tape Drive Operator's Reference Card*

Also, check the contents for damaged components. Notify your vendor immediately if any items are damaged. Keep all boxes and packing material for reshipment.

2.3 Preinstallation Procedures

Perform the following procedure before installing the TZ88 Model 20/40 GB DLT Cartridge Tape Drive.

2.3.1 Setting the SCSI ID Address of the Tape Drive

The storage enclosure slots are numbered 0 through 7, from top to bottom, with the power supply occupying slot 7. The SCSI address switches on the rear of the SBB (refer to Figure 2–1) are preset at the factory to *automatic* — SW-1, SW-2, and SW-3 set off (to left); SW-4, SW-5, and SW-6 set on (to right). This setting means that the SBB tape drive will have the address of whichever physical slot is connected. Because of the low position of the unit’s backplane interface connector, this physical connection will be to the lower of the three slots occupied by that unit. Physically, this means it will be one of slots 2 through 6, as applicable. If you want a different specific logical address for any reason (i.e., if you wish to use SCSI ID 0 or 6, or any specific value in between, regardless of physical location of the unit), you can set the tape drive to any desired logical address by manually changing the settings of switches SW-1, SW-2, and SW-3 on the SCSI switch pack, as delineated in Table 2–1, before inserting the SBB into the pedestal.

Figure 2–1 SWXTL-CA Tape Drive SCSI ID Switches

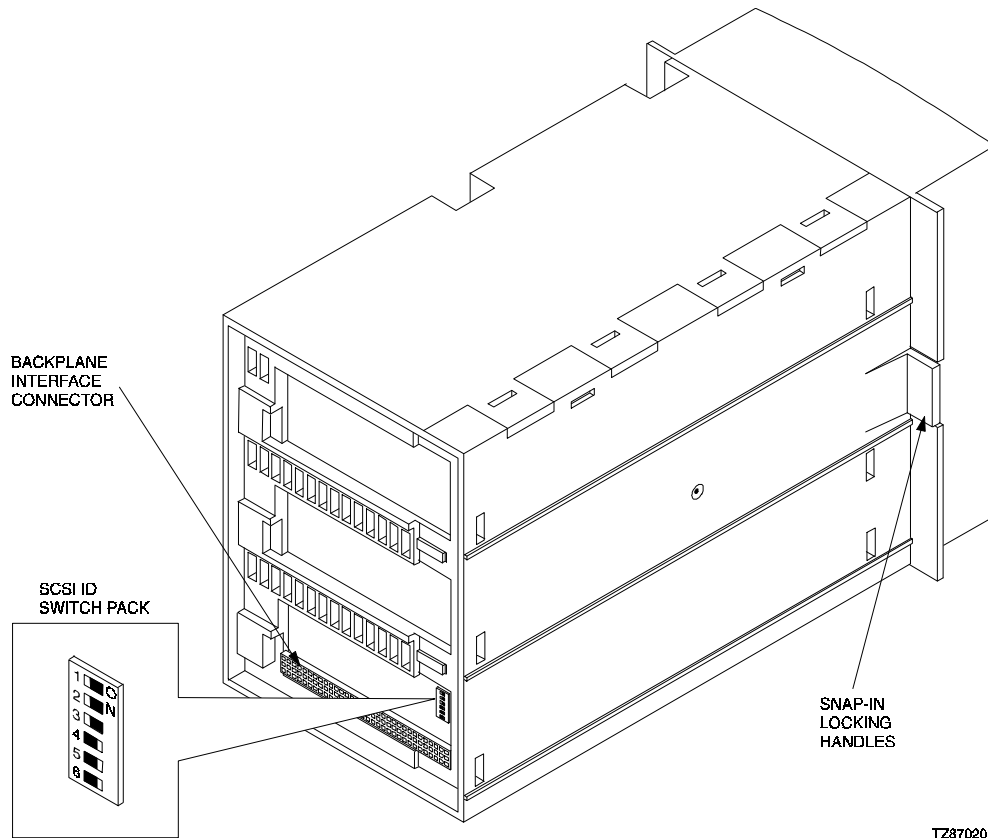

TZ870205

Table 2–1 SWXTL-CA Tape Drive SCSI ID Switch Settings

Address	SW-1	SW-2	SW-3	SW-4	SW-5	SW-6
0	Off	Off	Off	Off	Off	Off
1	On	Off	Off	Off	Off	Off
2	Off	On	Off	Off	Off	Off
3	On	On	Off	Off	Off	Off
4	Off	Off	On	Off	Off	Off
5	On	Off	On	Off	Off	Off
6	Off	On	On	Off	Off	Off
7*	On	On	On	Off	Off	Off
Automatic†	Off	Off	Off	On	On	On

* Normally reserved for host.

† Sets device address to storage subsystem slot number. “Automatic” is the default setting.

2.4 Installing the SWXTL-CA SBB Tape Drive Into a Storage Pedestal

CAUTION

Refer to the applicable documentation for your host computer and/or your specific operating system before installing the drive. This installation procedure assumes that you have already installed and appropriately cabled a StorageWorks Storage Expansion Pedestal and have checked out that subsystem as applicable, so that it is ready to receive this SBB unit.

You install the SWXTL-CA SBB tape drive in a storage enclosure by inserting the drive so that the connector on the lower portion of the rear surface fits into any available SCSI device storage slot.

The drive can be installed using the *hot-swap* method where the drive is installed with the host system powered on and operating, or with the cold-swap method where the host system is powered off. Before using the *hot-swap* method, consult your system administrator to ensure that your operating system supports this type of installation.

To install the tape drive:

1. Open the door on the front bezel of the StorageWorks Expansion Storage Pedestal subsystem (refer to Figure 2–2) and remove the bezel by pressing down on the plastic locking tabs at the bottom inside surface of the bezel (just in front of the power supply) and then pulling the bottom of the bezel forward, after which you can simply lift the entire bezel assembly free.
2. Remove the filler panel (or any previously mounted SBB) from the desired three adjacent device slots in the storage subsystem by squeezing the locking handles at the ends of each respective panel (or SBB) and removing the panel (or SBB).
3. Install the tape drive in the open slot, sliding the drive in firmly until its locking handles snap into place.
4. Perform the POST test, as described in the following subsection, to verify the operational integrity of the drive.

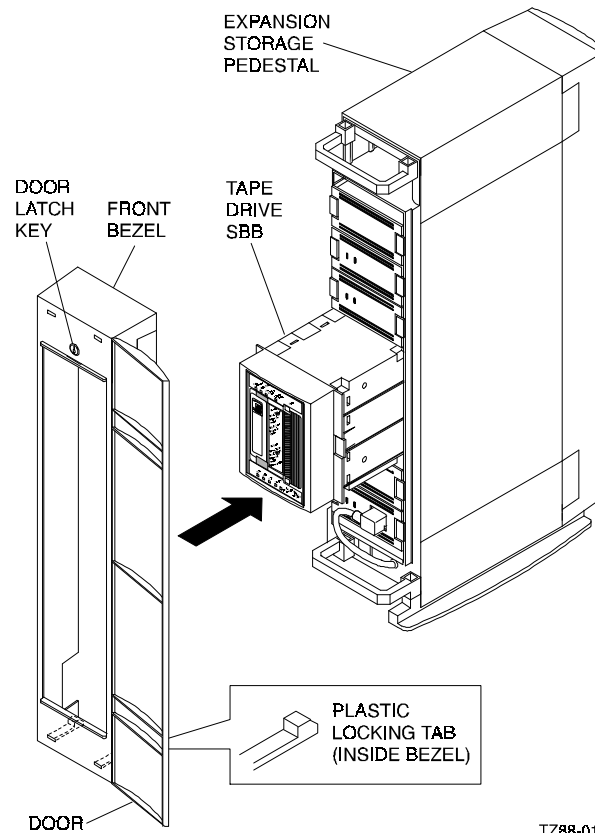
Figure 2–2 Installing the SWXTL-CA into an Expansion Storage Pedestal

TZ88-01

2.5 Power-On Self-Test (POST)

The power-on self-test (POST) exercise verifies the proper installation of the tape drive. The test can be performed with the host computer powered on, if your operating system permits, and with the SCSI bus either connected or disconnected. Refer to Figure 2–3 for the locations of the front panel LED indicators on the drive. To execute the power-on self-test, proceed as follows:

NOTE 1

The description of the indicator sequence described in the following procedure describes what happens when the TZ88 Model 20/40 GB tape drive is powered on.

NOTE 2

If all the left- or all the right-side indicators lit, the POST test has failed. Repeat the test to clear the failure (power off and then on). If the test still fails, replace the drive.

Figure 2-3 Tape Drive Front Panel Controls and Indicators

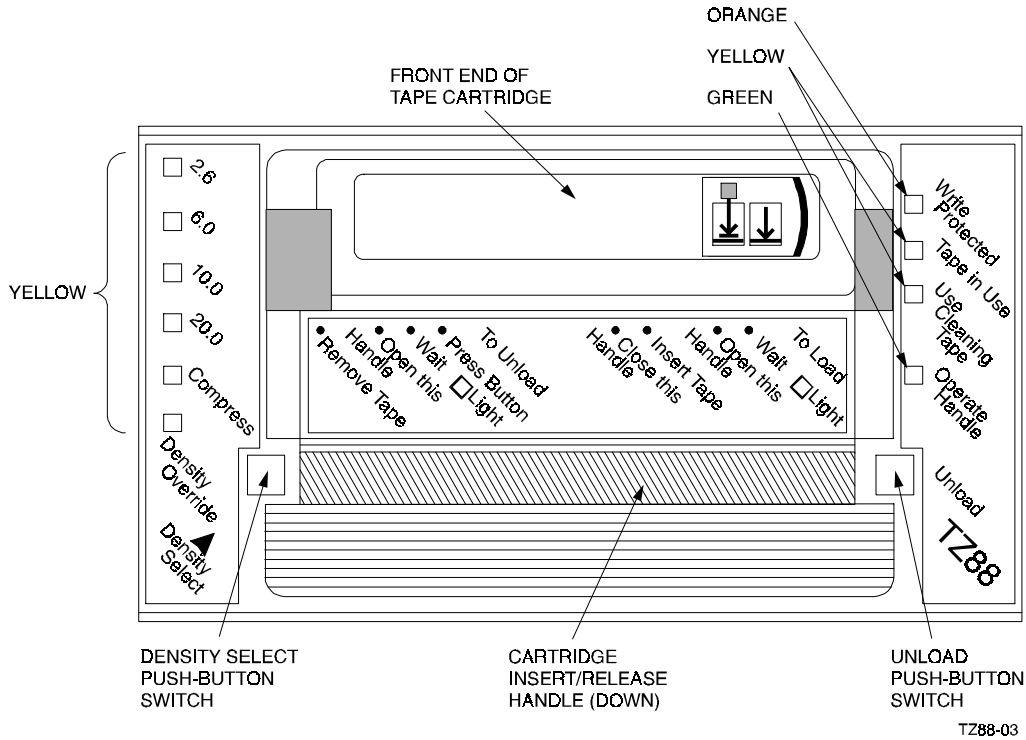

1. Ensure that there is no cassette tape in the drive.
2. Power on the TZ88 Model 20/40 GB DLT Cartridge Tape Drive device, either by cycling the storage enclosure's power switch off and on or, if other SBB units in that subsystem are active and should not be powered down, by hot-swapping the SBB unit under test (i.e., pull it free from the pedestal and then slide it back into its operating position).
3. Observe that all left-side panel indicators initially light, with all right-side indicators then lighting sequentially, from top to bottom.
4. All left-side panel indicators should go out within 1 second after power is applied. All right-side panel indicators remain lighted for 3 to 5 seconds and then go out, except for the Tape in Use indicator. This indicator continues to blink for a few seconds while tape mechanism searches for tape. When the indicator goes out, an internal beeper sounds to alert the operator and the green Operate Handle indicator becomes steadily lit indicating that the door latch is released and that the cartridge insert/release handle can be pulled up to allow insertion of tape.
5. Load a cassette tape into the drive (as shown in Figure 4-3) and observe the Tape in Use indicator. The indicator initially should blink momentarily at 1-second intervals after the handle is closed (pushed down) as the tape drive engages the tape, then double-blink at the same interval while the tape is being moved to the correct position. Depending on whether this is a new tape or a tape with some previously recorded data, this blinking period can extend from 20 seconds to a few minutes after the cassette is loaded, until the tape has reached the position for recording new data. The Tape in Use indicator should remain steadily on.
6. After the unit passes POST, connect the subsystem to your host computer through appropriate SCSI interface cables, and then have your system administrator assign a device name to the drive, if applicable.

NOTE

If you are connecting the tape drive to a fast, single-ended SCSI bus, the interface cable cannot exceed three meters (9.8 feet). If you are connecting the tape drive to a slow, single-ended SCSI bus, the interface cable can be up to 6 meters (19.7 feet) in length. In both cases, this maximum cable length includes not only the length of cable from the storage enclosure to the host computer but also the length of bus internal to the storage enclosure (including the backplane) and the length of bus internal to the host computer.

Installation and Operation of the SWXTL-CT Tabletop Tape Drive

This chapter provides specific details pertaining to the Tabletop Tape Drive that is designed to be operated as an independent standalone unit. The chapter tells how to unpack the tabletop unit, how to perform required preinstallation adjustments, set the SCSI address, operate the power-on self-test, and connect the unit to your host system.

3.1 Introduction

CAUTION

Refer to applicable instructions for your specific operating system before installing the drive and executing the power-on self-test procedure.

The SWXTL-CT Tabletop Tape Drive is an independent unit that requires a shelf space measuring at least 9-1/4" wide by 13" deep (plus cable connection space). Connection to your host computer is accomplished through a SCSI-bus interface cable. To install the drive, you first must set the SCSI ID address to the desired device number. You can then power-up the drive and confirm that the power-on self-test (POST) procedure confirms the operational integrity of your tabletop unit. Once you know the tape drive is fully operational, you can connect an applicable SCSI interface cable from the connector at the rear of the SWXTL-CT Tape Drive to the SCSI-bus interface card in your host system and, if applicable, terminate the SCSI bus.

This chapter describes how to unpack the received SWXTL-CT tabletop drive, how to prepare the drive for installation, how to set the parity capability and SCSI ID of the tape drive, how to perform the initial Power-On Self-Test (POST) procedure, and how to connect the tape drive to your host computer.

3.2 Unpacking

Unpack and inspect the contents of your shipment. It should contain the following items:

- This guide
- *CompacTape Handling and Storage Guidelines*
- *One StorageWorks TZ88 Model 20/40 GB DLT Cartridge Tape Drive Operator's Reference Card*
- One SWXTL-CT Tabletop DLT cassette tape drive
- One blank CompacTape IV cassette tape cartridge

- One CleaningTape III head-cleaning tape cassette
- One SCSI bus terminator
- One power cable

Also, check the contents for damaged components. Notify your vendor immediately if any items are damaged. Keep all boxes and packing material for reshipment.

Confirm that you have received, either as a separate shipment or as part of this same order, an appropriate SCSI-bus interface cable, corresponding to the type of SCSI interface controller mounted in your computer system. (Refer to Table 3–1).

Table 3–1 TZ88 Model 20/40 GB DLT Cartridge Tape Drive SCSI Interface Cables

Application	Drive-end Connector	Host-end Connector	Digital SCSI Cable Part Number	
Low-Density to-Low-Density Cable ¹	Low-Density 50-pin	Low-Density 50-pin	BC19J-1E	(18 inches long)
			BC19J-06	(2.0 meters long)
Low-Density to High-Density Cable ²	Low-Density 50-pin	High-Density 50-pin	BC23G-01	(3.0 feet long)
			BC23G-02	(6.0 feet long)

¹The 50-pin low-to-low-density cable is compatible with most ISA-type SCSI-bus adapters.

²The 50-pin high-density cable is compatible with either of:

- Most EISA-bus and PCI-bus SCSI adapters.
- Daisy-chain connection to StorageWorks storage enclosures.
- Most Sun, HP, and IBM single-ended adapters

3.3 Preinstallation Procedures

Perform the following procedure before installing the SWXTL-CT tape drive.

3.3.1 Setting the SCSI ID Address of the Tape Drive

The SWXTL-CT Tabletop Tape Drive contains a push-button counter switch in the upper right corner of the rear panel. The push-button counter is preset at the factory to SCSI ID 0, but you can easily set the tape drive to any desired specific address by manually changing the setting of the counter. The single-digit counter shows the current SCSI ID address selection. Each time you press the button located just above the counter readout, the counter (and the SCSI ID address) increments to the next higher value, until you reach 7, the upper limit. Each time you press the button located just below the counter readout, the counter (and the SCSI ID address) decrements to the next lower value, until you reach 0, the lower limit. Select an ID which does not conflict with a previously installed device.

3.4 Installation of SWXTL-CT Tabletop Tape Drive

The SWXTL-CT Tabletop Tape Drive is an independent unit that requires a shelf space measuring at least 9-1/4" wide by 13" deep (plus cable connection space). Connect the tape drive to an appropriate power source, using the supplied power cable, as follows:

1. Plug the female end of the power cord into the power jack at the rear face of the tape drive unit and then plug the other end of that cord into an appropriate power source, providing 120/240 Vac at 50/60 Hz.
2. Observe the POST test described in the following subsection to verify the operational integrity of the drive.

3.4.1 SWXTL-CT Power-On Self-Test (POST)

The POST test verifies operational integrity of the tape drive. The first time that you run this test, the SWXTL-CT tape drive unit should be disconnected from the host computer, with no tape cartridge in the drive. Once you have confirmed that the tape drive is operational, you can run the POST checkout with the host system connected, as desired. Refer to Figure 3-1 for the locations of the front panel LED indicators on the drive.

To execute the power-on self-test, proceed as follows:

NOTE

If all the left- or all the right-side indicators lit, the POST test has failed. Repeat the test to clear the failure (power off and then on).
If the test still fails, replace the drive.

1. Ensure that there is no cassette tape in the drive.
2. Power on the tape drive (depress top "I" portion of I/O rocker switch on rear panel).
3. Observe that all left-side panel indicators initially light, with all right-side indicators then lighting sequentially, from top to bottom.
4. All left-side panel indicators should go out within 1 second after power is applied. All right-side panel indicators remain lighted for 3 to 5 seconds and then go out, except for the Tape in Use indicator. This indicator continues to blink for a few seconds while tape mechanism searches for tape. When the indicator goes out, an internal beeper sounds to alert the operator and the green Operate Handle indicator becomes steadily lit indicating that the door latch is released and that the cartridge insert/release handle can be pulled up to allow insertion of tape.

Figure 3–1 SWXTL-CT Tape Drive Front Panel Controls and Indicators

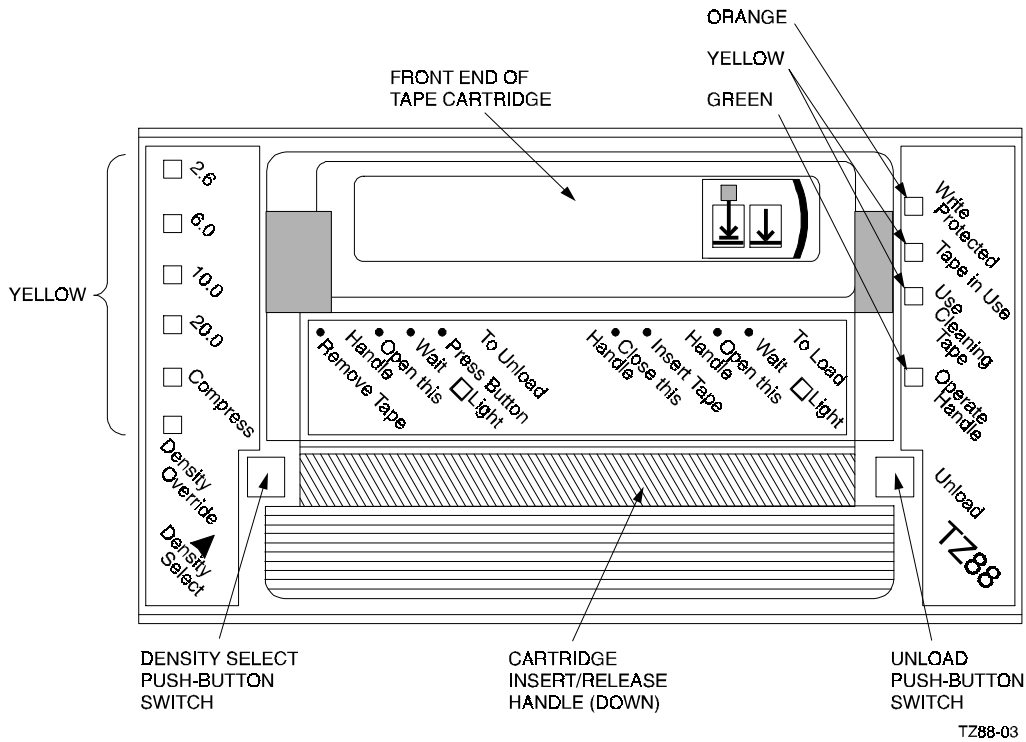

5. Load a cassette tape into the drive (as shown in Figure 4–3) and observe the Tape in Use indicator. The indicator initially should blink momentarily at 1-second intervals after the handle is closed (pushed down) as the tape drive engages the tape, then double-blink at the same interval while the tape is being moved to the correct position. Depending on whether this is a new tape or a tape with some previously recorded data, this blinking period should extend from 20 seconds to a few minutes after the cassette is loaded, until the tape has reached the applicable position for recording new data, after which the Tape in Use indicator should remain steadily on.
6. After the unit passes POST, turn the power off and connect the unit to your host computer through appropriate SCSI interface cables, as follows. If applicable, have your system administrator assign a device name to the drive.

NOTE

If you are connecting the tabletop tape drive to a fast, single-ended SCSI bus, the interface cable cannot exceed three meters (9.8 feet). If you are connecting the tape drive to a slow, single-ended SCSI bus, the interface cable can be up to 6 meters (19.7 feet) in length. Table 3–1 provides part-number identifications for ordering appropriate cables.

- a. Connect the appropriate 50-pin-connector end of the SCSI cable to either of the two vertically oriented jacks at the upper right rear of the tape drive unit.
- b. If this tape drive is the last unit on the SCSI bus, make sure that the supplied terminator is securely fastened in place in the adjacent connector.

- c. Connect the other end of the SCSI cable to the applicable connector provided on the SCSI controller card in your host system.
- d. After the unit is connected to the SCSI bus, you may wish to repeat the power-on self-test exercise to confirm the operational integrity of all connections.

Controls, Indicators and Operation

This chapter identifies the switches and LED indicators on the front panel of the TZ88 Model 20/40 GB DLT Cartridge Tape Drive, describes how to use them (including operation of the power-on self-test (POST), provides use rules for the CompacTape IV cartridge data and CompacTape III cleaning tapes, gives detailed procedures for correct loading and unloading of the tape cartridges, and explains how to select a desired density format for recording.

4.1 General

Digital's TZ88 Model 20/40 GB family of DLT Tape Drives offer outstanding performance and integrity, combined with ease of use. All normal-use operator controls are mounted on the front panel, consisting of two push-button switches, a pull-down handle, and several color-differentiated LED indicators to indicate operational status at any given time. The drive uses these indicators to "report" when the unit is ready for a tape, data format of the tape currently mounted, when the heads need to be cleaned, and when it is safe to take a tape out of the drive, as well as whether or not the tape cartridge currently is write-protected.

4.2 Front-Panel Controls and Indicators

All operating controls are located on the front panel (refer to Figure 4-1).

The cartridge insert/release handle provides simplified tape loading and unloading procedures, that are printed on the handle. This handle must be operated in order for a tape cartridge to be loaded or removed, but must not be operated unless the green Operate Handle indicator is lit.

The right-side front panel of the tape cassette drive contains four LEDs (Write Protected, Tape in Use, Use Cleaning Tape, and Operate Handle) and one push-button switch (Unload push-button).

Table 4-1 identifies each of these indicators/controls and gives the operating condition and function of each one.

The left-side front panel of the tape cassette drive contains six LEDs (2.6, 6.0, 10.0, 20.0, Compress, and Density Override) and one push-button switch (Density Select). Table 4-2 identifies each of these indicators/controls and gives the operating condition and function of each one.

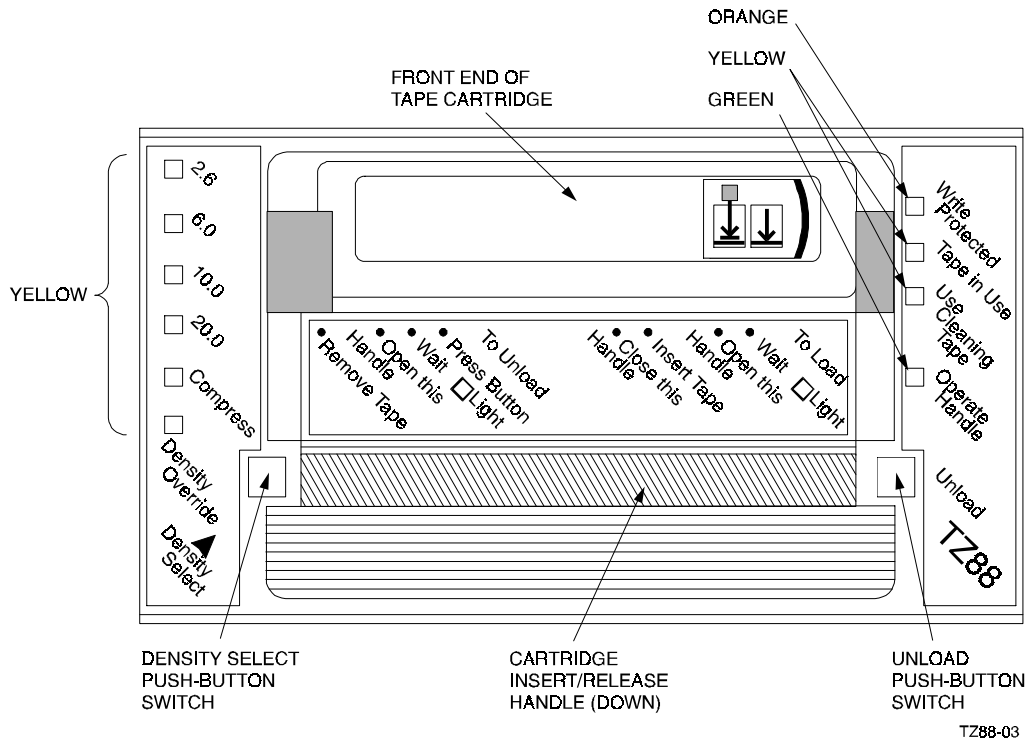
Figure 4–1 Front Panel Layout of TZ88 Model 20/40 GB DLT Cartridge Tape Drive

4.2.1 Unload Push-Button

CAUTION

Pressing the UNLOAD push-button during normal tape operations may halt the tape and result in the loss of data.

Pushing Unload causes the tape drive to rewind the tape and then unload the tape from the tape drive mechanism back into the cartridge. The tape must be completely rewound and unloaded into the cartridge before you remove the cartridge from the drive. Depending on the tape position when you press Unload, an unloading operation may take from 10 seconds to 3 minutes.

In the event that the tape drive is writing data to the tape when you press Unload, the 2 tape drive flushes any buffered write data to the medium before beginning the unloading sequence.

If the drive is in error state (all four right-side panel indicators flashing), pushing Unload causes the tape drive to reset and unload the tape.

4.2.2 Cartridge Insert/Release Handle

Operate the cartridge insert/release handle to load a cartridge or to eject a cartridge only when the Operate Handle indicator is lit. The handle lifts to the open position and lowers to the closed position. (See Section 4.5.3 for cartridge loading procedures, Section 4.5.5 for cartridge unloading procedures.)

Table 4–1 Right-side Front Panel Indicators and Controls

Label	Color	State	Operating Condition or Function
Write Protected	Orange	On	Loaded tape is write-protected.
		Off	Loaded tape is write-enabled.
Tape in Use	Yellow	On	Tape is loaded, ready for use.
		Blinking	Tape is moving.
Use Cleaning Tape	Yellow	On	Drive heads need cleaning, or else current data cartridge is bad.
		Remaining on after you unload cleaning tape.	Cleaning tape attempted to clean the drive heads, but was expired (insufficient cleaning area), so heads were not adequately cleaned.
		Turns on again when data cartridge is loaded after cleaning.	Data cartridge may be defective; try another cartridge.
		Off	Cleaning is complete or unnecessary.
Operate Handle	Green	On	Cartridge insert/release handle is unlocked and can be operated.
		Off	Cartridge insert/release handle is locked. Do not operate handle.
Unload		Recessed (pushed in)	Used to unlock the tape cassette door handle (press and hold for 1 to 2 seconds).
		At rest (out)	Normal inactive condition for this spring-loaded push-button switch.
All right-side front panel indicators		On (simultaneously)	Power-on self-test is starting.
		Blinking	An error has occurred. Press the Unload push-button or turn drive power off and then on again to clear the error.

4.2.3 Density Select Switch

Pushing (momentarily only) of the Density Select causes the tape drive first to enter the density-select mode and then, with each subsequent momentary pressing, to select the next-in-sequence density selection. In addition, this switch also functions as an enable/disable selection switch for the tape drive's compression capability when the drive is operating in the 10.0 or 20.0 GB density mode.

Table 4–2 Left-side Front Panel Indicators and Controls

Label	Color	State	Operating Condition or Function
2.6	Yellow	On	Indicates tape was last recorded in 2.6-GB format.
		Blinking	Indicates tape was last recorded in another density but has been selected for recording in 2.6-GB density for a write from BOT.
6.0	Yellow	On	Indicates tape was last recorded in 6.0-GB format.
		Blinking	Indicates tape was last recorded in another density but has been selected for recording in 6.0-GB density for a write from BOT.
10.0	Yellow	On	Indicates tape was last recorded in 10.0-GB format or 15.0-GB when used with a CompactTape IIIXT.
		Blinking	Indicates tape was last recorded in another density but has been selected for recording in 10.0-GB density for a write from BOT.
20.0	Yellow	On (default)	Indicates tape was last recorded in 20.0-GB format.
Compress	Yellow	On	Compression mode is enabled. (Compression can be done in 10.0- or 20.0-GB density, only.)
		OFF	Compression mode is disabled.
Density Override	Yellow	On	A density selection has been set from the drive's front panel.
		Off (default)	Density selection is under host control or else is automatic.
		Blinking	Unit is in density selection mode; pressing Density Select push-button at this time will cause next-higher density option to be selected.
Density Select		Recessed (pushed in)	If Density Override indicator is off, activates density selection mode, causing that indicator to blink. If Density Override indicator is blinking (meaning density selection mode is already active), causes next higher density option to be selected.
		At rest (out)	Normal inactive condition for this spring-loaded push-button switch.

4.3 Power-On Self-Test (POST)

The POST (Power-On Self-Test) test, which is performed automatically whenever the tape drive is powered on, verifies operational integrity of the tape drive. Operation of the POST exercise for the different models is delineated in Section 2 for the SWXTL-CT and Section 3 for the SWXTL-CT Tabletop, as part of the installation procedures, but is repeated here, generically, for convenience. The operation may be performed with the host system power on (if your operating system permits) or off, and with the SCSI bus connected or disconnected. (Refer to Figure 4–1 for the locations of the front panel LED indicators on the drive.)

NOTE

If all the left- or all the right-side indicators lit, the POST test has failed. Repeat the test to clear the failure (power off and then on). If the test still fails, replace the drive.

To execute POST, proceed as follows:

1. Power on the tape drive (if you are using the tabletop unit, depress top “T” portion of I/O rocker switch on the rear panel; if you are using an SBB mounted in a storage pedestal, turn on pedestal power or else pull the SBB tape drive out and then push it back into place).
2. Observe that all left-side panel indicators initially light, with all right-side indicators lighting sequentially, from top to bottom.

If the SCSI bus is not connected, all left-side panel indicators stay lit; if the SCSI bus is connected, all left-side panel indicators should go out within 1 second after power is applied. All right-side panel indicators remain lighted for 3 to 5 seconds and then go out except for Tape in Use indicator. This indicator continues to blink for a few seconds while tape mechanism searches for tape. Subsequent indicator activity depends on whether or not a tape cartridge is present in the tape drive, as defined in Table 4–3. (If a tape is present, the Tape in Use indicator continues to blink until the applicable point for recording new data is under the recording head, at which time that indicator becomes steadily lit. If no cartridge is present, the Tape in Use indicator goes out, the unit beeps, and the green Operate Handle indicator lights which indicates that the door latch is released.)

Following initialization, the drive is in one of the four states defined in Table 4–3.

NOTE

Under normal conditions, you should not power up a tape drive with a tape cartridge mounted, so that only conditions **a** and **d** in Table 4–3 would apply. The two intervening conditions, describing situations in which a tape was already mounted before power was applied, are included to cover emergency situations.

Table 4–3 Operating States of TZ88 Model 20/40 GB DLT Cartridge Tape Drive Unit Following Initialization

	Starting Condition	Status Light Sequence
a.	If no tape cartridge is mounted in drive and the drive passes POST.	<ol style="list-style-type: none"> (1) The yellow Tape in Use light turns off. (2) The internal audio-transducer alarm beeps. (3) The green Operate Handle light turns on. (4) The handle is unlatched. You can now raise the handle and insert a tape cartridge into the drive.
b.	If a cartridge is present in the drive and the cartridge insert/release handle is <u>down</u> . ¹	<ol style="list-style-type: none"> (1) The drive loads the tape cartridge. (2) The yellow Tape-in-Use light blinks while the tape is mounting and then lights steadily. (3) The left-side indicator corresponding with the last-written density format of the current tape cartridge lights. (4) The Density Override blinks. You can now select a density (refer to Selecting Density section); the drive is ready for use.
c.	If a cartridge is present in the drive and the cartridge insert/release handle is <u>up</u> . ²	<ol style="list-style-type: none"> (1) The yellow Tape in Use light turns off. (2) The internal audio transducer beeps. (3) The green Operate Handle light flashes. When you lower the handle, the cartridge loads.
d.	If the drive detects an error condition.	All right- or left-side lights blink repeatedly. Try to unload the tape and reinitialize the drive by pressing the Unload push-button or by turning drive power off and then on again (or, if you have an SBB, by hot-swapping that unit). If you do this, the right- or left-side lights stop blinking and the drive tries to reinitialize; if the attempt succeeds, the lights momentarily turn on steadily again and then go off.

¹ Not recommended. Shutting down power while a tape cartridge is still mounted in the drive can result in damage either to the tape cartridge (and/or its data) or to the drive, itself.

² Not recommended.

4.4 Status Indication of Tape Drive LEDs

The status of the tape drive under different conditions is indicated by the Write Protected and Tape in Use LEDs. In the normal operating state, the Write Protected LED only indicates the write-protect status and the Tape in Use LED only indicates the drive activity and load status. Table 4–4 describes the status conditions represented by the LEDs. Refer to Figure 4–1 to identify the LEDs on the front panel.

Table 4-4 Tape Drive LED Status

Status	Write Protected LED	Tape in Use LED
No tape loaded.	Off	Off
Tape loaded, write enabled.	Off	Yellow
Tape loaded, write-protected.	Orange	Yellow
No SCSI/drive activity.	Off†	Yellow (steady)
SCSI/drive activity.	Off†	Blinks on and off to track activity
Load sequence.	Off†	Blinks yellow @≈1-second interval (25% on). Yellow continuously when done. Indicates drive activity.
Unload sequence.	Off†, goes off.	Flashes yellow @≈1-second interval (25% on). Goes off when done. Indicates drive activity.
Reset sequence.	Orange Off†	Yellow, blinking. Normal indications.
Power on self test (POST).	Flashes orange @ 2 Hz for first few seconds, then goes off for remainder of power-up test sequence.	Double-flashes yellow @≈1-second interval for length of test. Normal activity indications when test complete.
Test complete, no failure.	Resume normal operation, off†.	
Test failure, drive fault.	Flashes orange @ 2 Hz.	Double-flashes yellow @≈1-second interval.

† If cassette is write-protected, orange Write-Protected LED will light.

4.5 CompacType IV DLT Tape Cassette

The data tape cartridge is a 4-1/8-inch, gray, plastic cartridge containing 1800 feet of 1/2-inch magnetic metal particle tape. The medium is a half-inch cartridge or ANSI-compatible equivalent. It is written and read using the interchange format proposed in the applicable pending ANSI X3B5 project.

NOTE

You can order the CompacTape IV data cartridge (Part No. TK88-01) and/or the cleaning cartridge (Part No. TK85-HC) from your reseller or by calling DECdirect at 800-DIGITAL in the U.S.A. or 800-27-6215 in Canada. (Refer to Table 1-1 for tape cartridge part numbers.)

CAUTION

Appropriate label cards are supplied with each tape cartridge. Always place the label in the recessed area on the cartridge. Never affix a label over another label. Also, please note that any substitute media must meet ANSI X3B5 certification requirements.

To ensure optimal performance from your cassettes tapes, observe the care and handling guidelines provided in Section 4.5.7, Preserving Cartridges.

4.5.1 Write-Protect Switch

The tape cartridge has a write-protect slide-bar switch on the right side of its front surface so that you can prevent the accidental overwriting of data stored on the tape (see Figure 4–2). To read or copy from the tape cassette, slide the write-protect bar-switch to the left, so that an orange area is exposed in the rectangular aperture directly over the left-side arrow on the switch, indicating that the tape is in its “write-protected” state. This prevents writing to the tape and ensures that data will not be accidentally overwritten. Use the following guidelines when setting the write-protect tab:

- If you are reading data (copying from tape), set the write-protect tab to “Write Protected” (to the left, orange area showing).
- If you are writing data (writing to tape), set the write-protect tab to “Write Enabled” (to the right, orange area not showing).
- When loading a tape cassette into the drive, make sure the cassette's write-protect tab is on the right, facing you.

Figure 4–2 CompacTape IV Data Tape Cartridge

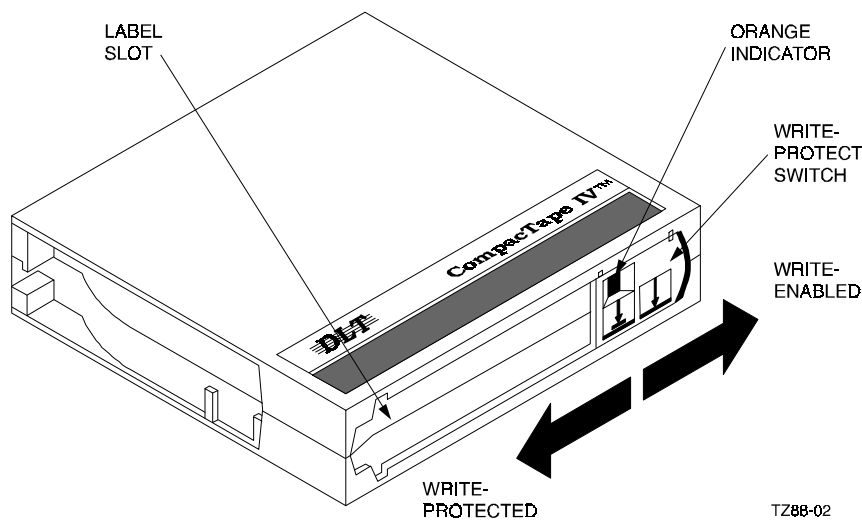

4.5.2 Data Protection

If you move the cartridge write-protect switch to the left, the drive turns on the Write Protected LED immediately. If the drive is writing to the tape when you move the switch, however, write-protection does not take effect until that write has been completed.

Table 4–5 describes what happens to data protection when you move the write-protect switch before loading the cassette.

Table 4–5 Moving Write-Protect Switch Before Tape Drive Operation

If you move the Write Protect switch ...	Then ...
To the left, with the orange area showing through the aperture above the left arrow symbol on the switch ...	The tape drive cannot write data to the tape.
To the right, with no orange area showing in the aperture above the left arrow on the switch ...	The tape drive can write data to the tape (if the tape is not software write-protected).

Table 4–6 describes what happens to data protection when you move the write-protect switch during operation.

Table 4–6 Moving Write-Protect Switch During A Read/Write Operation

If you move the Write Protect switch ...	Then ...
From the write-protected position (left) to the write-enabled position (right, no orange area showing in aperture above left arrow symbol) ...	The tape becomes write-enabled <i>after</i> a variable amount of time (in the order of seconds).
From the write-enabled position (right) to the write-protected position (left, orange area showing in aperture) ...	The tape becomes write-protected after a variable amount of time (in the order of seconds, unless write operation is in process, in which case the effect does not become active until that write operation is completed).

4.5.3 Loading A Cartridge

The cartridge insert/release handle on the front of the drive provides outline procedures for loading a cartridge into the tape drive (right side of handle) and unloading a cartridge from the drive (left side of handle). The following is a more detailed version of the procedure for loading a cartridge (refer to Figure 4–3).

CAUTION

Never operate the cartridge insert/release handle unless the green Operate Handle indicator is steadily lit.

1. When the green Operate Handle indicator is lit steadily, pull the cartridge insert/release handle open by pulling the bottom edge up and forward.
2. Insert the rear end of the cartridge (opposite from the surface containing the write-protect switch) into the aperture behind the handle, right side up (name on top, with arrows on write-protect switch on front pointing down).
3. Push the cartridge assembly into the drive until the cartridge reaches its full-stop position, with the cartridge fully pressed into the unit.
4. Push the insert/release handle closed by pushing front edge back and down.
After the door becomes closed, the green Operate Handle indicator goes out and the yellow Tape in Use indicator blinks to show that the tape is loading. When the tape is at the BOT (beginning of tape) marker, the yellow Tape in Use indicator lights steadily. The tape is then ready for use.

Figure 4-3 Loading Cartridge Into Tape Drive

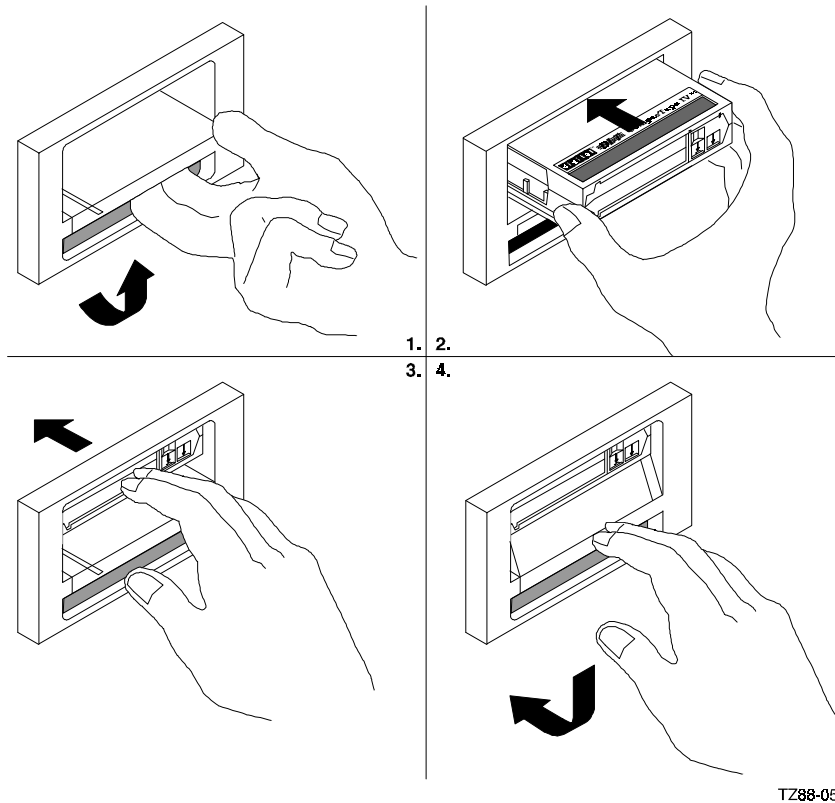

4.5.4 Tape in Use

When the yellow Tape in Use light is on steadily, the tape is ready for use. While the tape is being read, written to, or rewound, the yellow Tape in Use indicator blinks. Table 4-7 describes what is happening during cartridge use:

Table 4-7 What is Happening During Cartridge Use (Right-Side Indicators)

	If ...	It means ...
1.	The yellow Tape in Use indicator is on steadily.	A cartridge is loaded, but the tape is not moving. This condition can mean that no application is communicating with the controller, or that the application is communicating but is not delivering commands for tape motion.
2.	The yellow Tape in Use indicator blinks irregularly.	A read or write is in progress.
3.	The yellow Tape in Use indicator blinks regularly.	The tape is loading, unloading, or rewinding.
4.	The audio transducer beeps and the green Operate Handle indicator turns on.	The tape is unloaded.
5.	All four right-side indicators blink.	An error has occurred during operation.

4.5.5 Unloading A Cartridge

NOTE

The following procedure presumes that the operator manually initiates the unloading sequence by pressing the Unload push-button. In some host-driven applications, the application software may issue the appropriate system software command to initiate the unloading sequence, producing the same effect.

1. Press the Unload push-button on the front panel's right side (or issue the appropriate system software command). The yellow Tape in Use indicator blinks as the tape rewinds.
2. When the internal audio transducer beeps and the green Operate Handle indicator lights steadily, pull the cartridge insert/release handle open by pulling the bottom edge up and forward. (Refer to Figure 4-4).
3. Remove the cartridge by pulling it forward from the aperture.
4. Push the insert/release handle closed by pushing front edge back and down.

Figure 4-4 Unloading Cartridge From Tape Drive

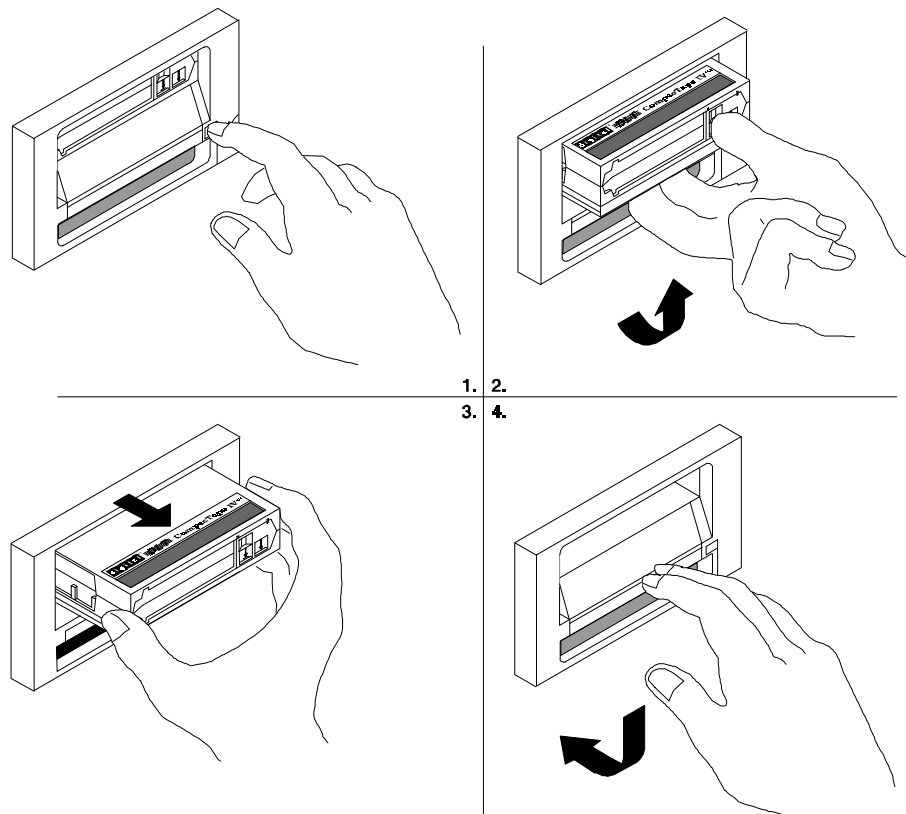

TZ88-06

4.5.6 Using the Tape Cleaning Cartridge

Table 4–8 explains when you should use the cleaning cartridge.

NOTE

The cleaning cartridge expires after approximately 20 uses, after which time there is insufficient cleaning area remaining on the cleaning tape to adequately clean the heads.

Table 4–8 When To Use the Cleaning Cartridge

	If ...	It means ...	And you should ...
1.	The yellow Use Cleaning Tape indicator lights.	The drive heads need cleaning or the tape is defective (see Item 3, in this table).	Use the cleaning cartridge. Follow the instructions in Section 4.5.5 for unloading the data cartridge, then follow the instructions in Section 4.5.3 to load the CompacTape III Cleaning tape into the drive. The cleaning operation begins automatically as soon as the cartridge insert/release handle becomes closed. When cleaning is complete, the internal beeper sounds to tell you to remove the cleaning cartridge.
2.	A particular cartridge causes the Use Cleaning Tape indicator to turn on frequently.	The data cartridge may be defective.	Back up this data on another cartridge, and then discard the old cartridge. A damaged cartridge may cause unnecessary use of the cleaning cartridge.
3.	The Use Cleaning Tape indicator turns on after you clean the drive heads and reload your data cartridge.	Your data cartridge may be causing the problem.	Try a different data cartridge.
4.	The Use Cleaning Tape indicator is on after you load the cleaning cartridge.	Cleaning has not been done and the cleaning cartridge has expired.	Discard and replace the cleaning cartridge.

4.5.7 Preserving Cartridges

CAUTION

Remove a cartridge from the tape drive before turning off or powering down the host system. Failure to remove a cartridge can result in damage to the cartridge and/or to the tape drive.

To prolong the life of a cartridge, return the cartridge to its plastic case and secure the case cover when you remove the cartridge from the tape drive.

To maximize the life of recorded or unrecorded cartridges, store cartridges in a clean environment with the following conditions:

- Do not drop or bang the cartridge. Doing so can displace the tape leader, making the cartridge unusable and possibly damaging the drive.
- Keep tape cartridges out of direct sunlight and away from heaters and other heat sources.
- Store tape cartridges in temperatures between 10°C and 40° C (50°F to 104°F). For longer cartridge life, always store the cartridge in its plastic container and in room environment conditions of 72°F ± 7°F (22°C ± 4°C).
- If the tape cartridge has been exposed to heat or cold extremes, stabilize the cartridge at room temperature for the same amount of time it was exposed—up to 24 hours.
- Do not place cartridges near electromagnetic interference sources, such as terminal, motors, video, or X-ray equipment. (Data stored on the tape can be altered by the electromagnetic interference created by such sources.)
- Store tape cartridges in a dust-free environment where the relative humidity is between 20% and 80%. For longer cartridge life, store the cartridge at 40% ± 20% relative humidity.
- Place an identification label only in the slide-in slot on the front of the cartridge; do not affix any adhesive label to the surface of the cartridge.
- Do not adhere labels to the cartridge anywhere except in the slide-in slot.

4.6 Selecting Density

The TZ88 Model 20/40 GB DLT Cartridge Tape Drive is designed to write and read in either 20-GB (uncompressed) or 40-GB (compressed) data format on DLT cartridge tapes. The tape drive also can both read and write in lower-density formats used in earlier DLT systems, as designated in Table 4–9. All selections, including the compression mode (which constitutes another density selection), are selectable by the Density Select push-button switch. This section describes the TZ88 Model 20/40 GB DLT Cartridge Tape Drive’s density select features.

Table 4–9 Density Selections Available On TZ88 Model 20/40 GB DLT Cartridge Tape Drive

Front Panel Designation	Cartridge Type/Format	Storage Capacity
2.6	CompacTape III/TK85	2.6 GBF
6.0	CompacTape III/TK86	6.0 GBF
10.0	CompacTape III/TZ87	10.0 GBF, uncompressed; 20.0 GBF, compressed
	CompacTape IIIXT/TZ87X	15.0 GBF, uncompressed; 30.0 GBF, compressed
20.0	CompacTape IV/TZ88	20.0 GBF, uncompressed; 40.0 GBF, compressed

CAUTION

If you reuse a tape on which other data was previously recorded, and write from the Beginning Of Tape (BOT), all previously recorded data is lost, including density changes.

4.6.1 How To Select Density At The Front Panel

To select density with the TZ88 Model 20/40 GB DLT Cartridge Tape Drive:

1. Insert a tape cartridge into the tape drive. The yellow Tape in Use indicator blinks while the tape loads and calibrates.
2. Wait until the yellow Tape in Use indicator becomes and remains steadily lit, indicating completion of the calibration process.
3. Press and release the Density Select push-button on the front panel's left side one time (momentary depression only; do not hold down) to enter the density-select mode. The Density Override indicator lights. If this is a previously recorded cartridge, the indicator corresponding to the density selection used the last time this tape was written to also lights.
4. Press and release the Density Select switch again (momentary depression, only) to cause the indicator corresponding to the next-in-sequence density option to blink, and repeat this action as necessary until the indicator corresponding to the desired density option is blinking. (If this cartridge was previously recorded in a different format, the indicator corresponding to the tape's current density selection remains steadily lit. If this is a blank tape, each indicator goes out when the next-in-sequence density is selected, except that the 10.0 or 20.0 indicator remains lit if you press the Density Select button again to enable compression mode, in which case both the density indicator and Compress indicators will be blinking.)
5. After the host system writes new data to the tape in the selected format, the indicator corresponding to the selected density lights steadily, and the indicator identifying the last-used density option goes out.

4.6.1.1 Selection of 40-GB Compression Mode

Depending on the type of data involved, the TZ88 Model 20/40 GB DLT Tape Drive can store up to double the amount of data on a tape. This compression capability is another density selection. When the tape drive is operating in regular 20.0 mode (only the yellow 20.0 indicator is lit), the tape drive can store up to 20 GB on a CompacTape IV DLT data cartridge and can transfer data (read or write) at a rate of up to 1.5 MB/s. When the tape drive is operating in compressed 40.0 mode (both the yellow 20.0 indicator and the adjacent Compress indicators are lit), the tape drive can store up to 40 GB on a CompacTape IV cartridge with data transfer rates of up to 3.0 MB/s (write) and 3.5 (read).

4.6.1.2 Reformatting a 2.6-GB Formatted Tape to 10-GB

CAUTION

If you reuse a tape on which other data was previously recorded, and write from the Beginning Of Tape (BOT), all previously recorded data is lost, including density changes.

Suppose, for example, that you have installed a CompacTape III tape cartridge with a prerecorded 2.6-GB density, and you use the Density-Select push-button to select the 10.0 density. You should observe the following:

- The Density Override indicator is lit, indicating that a density selection has been made from the front panel.
- The 2.6 indicator lights and remains lit, indicating that the tape was previously recorded at the 2.6-GB density.
- After you momentarily press the Density Select push-button a second time, the 10.0 indicator blinks, the 2.6 indicator remains steadily lit. The reformatting write process begins after the appropriate command is issued from the host computer.

After the completion of the write from BOT, you should observe the following:

- The 10.0 indicator becomes steadily lit.
- The 2.6 indicator goes out.
- The Density Override indicator remains lit.

If you momentarily press the Density Select push-button after the drive has completed the 10-GB reformat, the tape drive goes into its compression mode. The 10.0 indicator remains lit and the Compress indicator lights. Assuming a 2:1 data compression ratio, 20-GB of data can be stored on a CompacTape III.

4.6.2 Density Selection Rules

Density selection occurs in accordance with the following rules (See also Table 4–10):

READ or WRITE APPEND Density Selection

The indicator on the left side of the front panel of the drive will designate the density of the tape currently mounted in the drive.

WRITE From BOT Density Selection

Full-tape density for a new tape or one that is to be reused may be selected by:

- Use of the front-panel Density Select push-button. (Using the Density Select push-button always overrides an existing selection.)
- Programmable host commands from the application software.
- If neither of these two conditions exists, however, the selected density will be the default, native 20.0 mode (with compression enabled).

CAUTION

Regardless of the operating conditions, a write from BOT destroys existing data on the tape.

NOTE

You can use the drive's control panel at various times, not just after loading a tape. Density selection will be inactive until a write command is issued (at BOT). The controller remembers the last-used density selection state until you do one of the following:

- Change the density selection.
- Unload the tape.

Table 4–10 Results of Density Selection

If ...	Then ...
You did not press the Density Select push-button.	The corresponding indicator on the left side of the front panel lights to show the actual density of the loaded tape while the tape is reading or writing. The applicable drive density indicator lights steadily, and the Density Override indicator is not lit.
You pressed the Density Select push-button, and the actual (last-used) density of the tape loaded in the drive is the same as the density you selected.	Both the indicator for the actual density and the Density Override indicator light.
You pressed the Density Select push-button, and the actual (last-used) density of the tape loaded in the drive differs from the selected density option.	<p>The following conditions should occur during the initial portion of the writing process:</p> <p>The Density Override indicator lights steadily.</p> <p>The indicator next to the designation of the actual (last-used) density designation lights steadily.</p> <p>The indicator next to the designation of the desired density option blinks.</p> <p>If the actual/default density of the currently loaded tape is 6.0 GB, for example, and you have selected the 10.0 density option, the 6.0 indicator initially lights steadily to show the current format, the 10.0 indicator initially blinks to show that you have selected that format, and the Density Override indicator remains steadily lit until the BOT signal is processed, marking the actual beginning of writing. After that actual writing begins, the Density Override indicator remains steadily lit during the writing process, but the 6.0 indicator goes out and the 10.0 indicator becomes steadily lit.</p>

Maintenance

This chapter describes preventive maintenance and troubleshooting for the TZ88 Model 20/40 GB DLT Cartridge Tape Drive. It identifies common errors, describes how to clean the heads of the tape drive, and provides a troubleshooting table to help diagnose common problems.

5.1 Introduction

This chapter describes what to do if you have problems with your tape drive or tape.

5.2 Common Errors

5.2.1 Avoiding Basic Problems

You can avoid some errors by following these basic guidelines:

- Use the correct cartridge type, as delineated in Chapter 1, Table 1–1. (Any substitute media must comply with ANSI X3B5 certification requirements.)
- Care for your cartridges (both data and cleaning) in accordance with the guidelines in Chapter 4.
- Make sure the cartridge leader and the drive leader are in their correct positions. (Refer to Section 5.4.)
- Unload the cartridge before powering down the tape drive.
- Do not load a cartridge until after tape drive is initialized.

5.2.2 Error Influences

If an error occurs during tape drive operation, you may be able to correct the error yourself. Factors influencing errors include the following:

- Defective media.
- Dirty drive heads.
- Operator or user errors.
- Incorrect backup commands.

Use Table 5–1 to interpret error symptoms, determine their cause, and to take corrective action.

Table 5–1 Possible Corrections for Common Error Situations

Symptom	Probable Cause	Possible Correction
Failure to mount or read/write with new or used cartridge.	Bad cartridge.	Retry same operation with a different cartridge.
	Dirty drive head(s).	Use CleaningTape III head-cleaning cartridge (see Section 4.5.6).
Application software-generated initialize command fails with parity error.	Tape calibration failed.	Use CleaningTape III head cleaning cartridge, or else try a different data cartridge.
Green Operate Handle indicator stays lit and tape does not move; Yellow Tape in Use indicator is lit but does not blink.	Cartridge loading error.	Dismount the cartridge and inspect it for a mispositioned leader (see Section 5.4.1 in this chapter). If the drive leader is not in the correct location, call your reseller or Digital services.
		Inspect the drive for a damaged, misplaced, or unhooked leader (see Section 5.4.2 in this chapter). If the drive leader is not in the correct location, call your reseller or Digital services.
All right-side or left-side indicators are blinking.	Drive failed self-test or detected a hard error during operation.	Try to clear the error by pressing the Unload button, or turn power off and then back on again. If the error does not clear (the tape does not rewind and unload, and the lights blink), you have a hardware failure; call your reseller or Digital services.

5.3 Cleaning the Heads

This section describes how to clean the heads of the tape drive. The heads are the components that physically read and write data to and from the cassette tape (media). We recommend that you perform the head-cleaning procedure approximately every two weeks, or after 50 hours of drive usage. Under normal conditions, it should not be necessary to exceed this cleaning schedule. If a particular cassette causes problems, try another data cassette.

CAUTION

Never attempt to clean the heads in a manner other than described in the following procedure. Doing so will void the product warranty.

To clean the heads, use the CleaningTape III head-cleaning cartridge, as follows:

1. Apply power to the tape drive and wait for the internal audio transducer to beep and the green Operate Handle indicator to light.
2. Pull open the cartridge insert/release handle and insert the yellow CleaningTape III head-cleaning cassette (Part No. TK85HC) into the drive for its full length, then close the handle (refer to Figure 4–3).

3. When you close the cassette insert/release handle after inserting the tape, the drive automatically executes the head-cleaning operation, which takes at least 30 seconds. When the head-cleaning cassette has completed this task, the tape drive electronics (1) stop the drive, (2) unlatch the cartridge insert/release handle, and (3) turn on the green Operate Handle indicator so that you can remove the head-cleaning cartridge.
4. Mark the frequency-of-use label on the head-cleaning cassette, placing a check mark in the next-available square on the card each time you use the head-cleaning cassette.

CAUTION

Remove the head-cleaning cassette as soon as possible following completion of the cleaning operation. Leaving a head-cleaning cassette in the drive might result in redundant cleaning operations each time power to the tape drive unit is turned off and on, resulting in unnecessary wear on the tape drive's read/write heads.

Under normal conditions, the head-cleaning cassette is effective for about 20 cleanings. If the head-cleaning cassette has been overused, so that it is expired, the Use Cleaning Tape will remain lit after you load the cleaning cassette, and no cleaning action will take place. If this happens, try another cleaning tape.

5.4 Inspections

5.4.1 Checking the Cartridge Leader

CAUTIONS

Do not touch exposed magnetic tape inside your tape cartridge; the normal oil on your skin can damage the tape and cause subsequent problems with respect to writing new data or reading data already stored.

If the tape leader inside the cartridge is not in the correct position, do not try to fix it. Instead, discard that cartridge and substitute a different cartridge.

Before you use a tape cartridge, be sure its tape leader is in the correct position, as illustrated in Figure 5–1. Lift the door latch with your thumb and open the small door on the rear face of the cartridge to expose the leader.

5.4.2 Checking the Drive Leader

To examine the drive take-up leader, tilt the cartridge receiver door on the front of the drive and look inside to see that the drive leader is connected to the buckling link-hook, which should be engaged in the leader slot as illustrated in Figure 5–2 and Figure 5–3.

Figure 5-1 Checking the Cartridge Leader

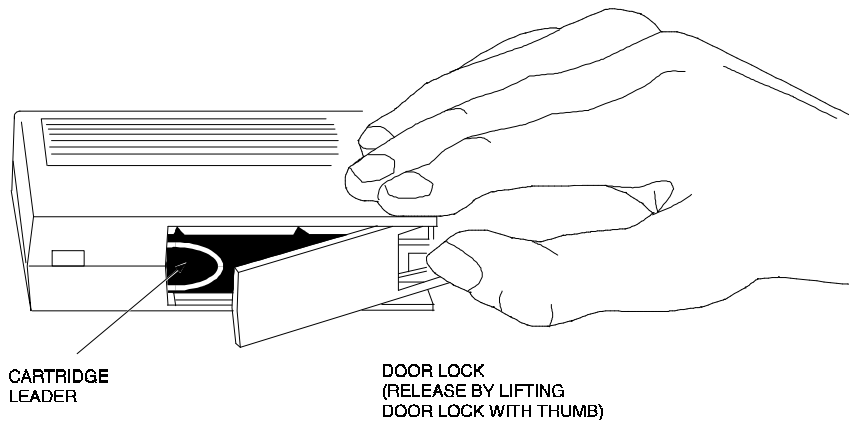

TZ870-01

Figure 5-2 Correct Engagement of Take-Up Leader in Tape Drive

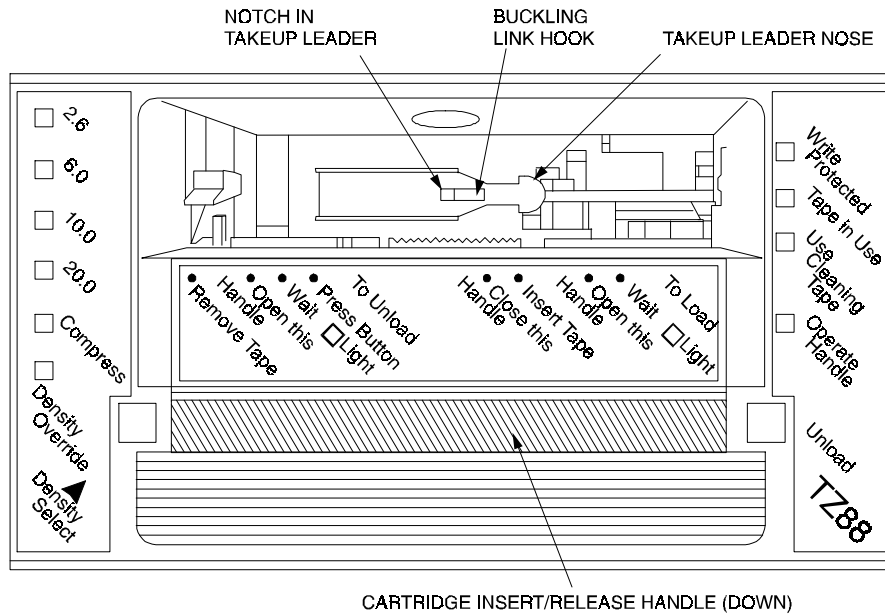

TZ88-07

Figure 5-3 Correct and Incorrect Positions of Tape Drive Leader

ACCEPTABLE

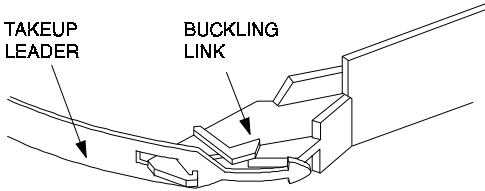

**CORRECT
LOCATION
OF TAKEUP
LEADER NOSE
IN FRONT
OF LINK**

NOT ACCEPTABLE

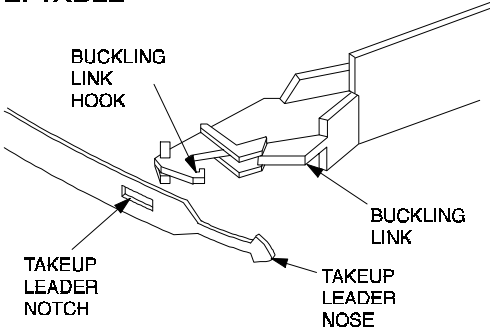

**LEADER
UNHOOKED**

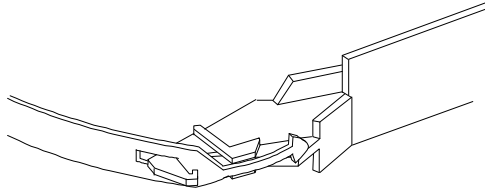

**TAKEUP
LEADER NOSE
DISPLACED
ABOVE
LINK**

TZ870403

5.5 Troubleshooting

Table 5–2 describes some common drive problems and suggests possible solutions.

Table 5–2 Troubleshooting Table

Symptom	Probable Cause	Possible Solution
Unable to back up or copy data to tape.	Cartridge write-protected. No tape in drive.	1. Set write-protected tab on cartridge to write-enabled. 2. Insert tape.
Write Protected indicator flashes orange.	Excessive tape errors.	Perform head cleaning procedure (Section 5.3) . If error repeats, try another tape.
Tape in Use and Write Protected LEDs flash rapidly in unison.	Dirty heads or bad media. Drive error, possibly a hard failure.	Eject tape. Perform head cleaning procedure (Section 5.3) . If error repeats, try another tape. Eject tape. Power off and power on the drive. If error repeats, replace the drive.
After applying power, nothing happens. All indicators off, except green Operate Handle indicator.	No tape loaded.	Load tape.
Drive not available to system.	Drive not plugged in. (If SBB unit, Storage Expansion Pedestal may not be plugged in.) SCSI ID switches set to incorrect address. Defective SCSI cable.	1. Check ac power source. 2. Check SCSI ID switch settings. 3. Ensure power cable is plugged in and SCSI cable is seated properly.



Specifications

This appendix describes the physical, electrical, and environmental specifications for the TZ88 Model 20/40 GB DLT Cartridge Tape Drive, covering both the SWXTL-CA StorageWorks Building Block (SBB) & the SWXTL-CT Tabletop DLT Cartridge Tape Drive.

Table A–1 TZ88 Model 20/40 GB DLT Cartridge Tape Drive Specifications

Characteristic	Specification(s)
Performance	
Read/write speed	110 in/s, streaming
Transfer rate, raw native	2.5 MB/s
Transfer rate, user native	1.5 MB/s
Transfer rate, user compressed	Over 3.0 MB/s maximum Write Over 3.5 MB/s maximum Read
Repositioning time (typical)	1.3s
Error rate, detected	1 in 10^{17} bits read
Error rate, undetected	1 in 10^{30} bits read (calculated)
Error correction code	Custom Reed-Solomon ECC
Drive interface	SCSI-2
Passes per cassette tape	Over 500,000 passes
Power requirements (SWXTL-CT)	120/240 Vac @ 60/50 Hz
Data organization	
Recording format	128-track serial serpentine fixed block
Recording density	62,500 bits/in
Track density	256 tracks/in
Data encoding	2,7 RLL
Record size	Variable up to 64 KB with 4-KB blocking factor
Data compression algorithm	DLZ
Maximum capacity (formatted)	40 GB (per cartridge) [†]

[†] Assumes a 2:1 compression ratio.

Table A-1 TZ88 Model 20/40 GB DLT Cartridge Tape Drive Specifications (Continued)

Characteristic	Specification(s)
Recording medium:	
Tape	0.5 metal particle (MP) tape, 1400 to 1500 Oersted, 360 micro inches thick
Length	Type IV: 1780 ft (usable)
Cartridge	CompacTape IV 0.5-in tape in a 4.1x4.1x1 in cartridge
Durability	500,000 tape-head passes
Shelf life	10 years minimum @20°C and 40% RH (noncondensing)
Operating environment:	
Temperature	10°C to 40°C
Relative humidity	20% to 80% noncondensing
Altitude (maximum)	8,000 ft
Software support	Refer to Appendix B

Physical Characteristics	
SWXTL-CA SBB Tape Drive	
Height	14.52 cm (5.72 in)
Width	23.49 cm (9.25 in)
Length	33.22 cm (13.08 in)
Weight	7.7 Kg (15.9 lb)
SWXTL-CT Tabletop Tape Drive	
Height	13.49 cm (5.31 in)
Width	23.50 cm (9.25 in)
Length	33.22 cm (13.08 in)
Weight	7.7 Kg (16.9 lb)

B

Product Notes for Windows NT, Novell[™] and MS-DOS[™]

This appendix provides information for the system administrator, who should read this appendix before installing and using the TZ88 Model 20/40 GB DLT Cartridge Tape Drive (SWXTL-CA or SWXTL-CT) with a host system operating under the Windows NT, Novell, MS-DOS, or MS-DOS/WINDOWS operating systems.

B.1 Host SCSI Interface

The TZ88 Model 20/40 GB DLT Cartridge Tape Drive devices (SWXTL-CA and SWXTL-CT) use the standard SCSI-2 command set to interface to the PC-based host system. Therefore, the host system must be equipped with a SCSI adapter to properly interface the tape drive with the host. For example, the host SCSI adapter might interface the computer's PCI bus to the SCSI-2 port of the tape drive.

A host PC SCSI adapter is normally supplied with a compatible software driver for use with its operating system. When operating under the Novell and MS-DOS or under the MS-DOS/WINDOWS operating systems, the software driver must be preloaded in accordance with the SCSI adapter manufacturer's installation procedure in order to ensure a proper interface between the TZ88 Model 20/40 GB DLT Cartridge Tape Drive and the host. In addition, a user-level tape read/write software program may be required to implement tape support under the Novell, MS-DOS, or Windows NT¹ environments. There are many commercial software products available that provide host or network-based functionality (data backup and restore, archiving, data logging, etc.) for these operating systems.

Before purchasing a user-level software product, ensure that the TZ88 Model 20/40 GB DLT Cartridge Tape Drive is supported by that product (see note below). Commercial software vendors usually publish a supported hardware list, or have telephone technical support personnel that will answer questions regarding compatibility of a particular tape drive or other storage devices. When choosing a software product suitable for your application, follow the software vendor's installation procedure to implement support for your tape drive.

Finally, if your host is operating under Novell Netware, Novell, Inc. provides a software product called "Server Backup" with some of its operating system products. This program has been found to work well with the SWXTL-CT Tape Drive SBB.

¹ Windows NT support under Version 3.51 with a service pack.



Product Notes for Sun™

This appendix describes how to include the TZ88 Model 20/40 GB DLT Cartridge Tape Drive SBB in a Sun SPARC system running Solaris™ 2.3 (or later) and SunOS™ 4.1.x. The information covers the installation of the TZ88 Model 20/40 GB DLT tape drive hardware and configuring the system to communicate with the drive.

C.1 General Information

Densities can only be changed at the beginning of the tape.

Front panel operation will override software control of density and compression settings.

To use software-controlled density selections, the drive must first be placed in “automatic” mode. To accomplish this, press the DENSITY SELECT button the required number of times until only the DENSITY OVERRIDE light is blinking.

Compression can be enabled or disabled at any time, with the change taking effect immediately when writing TZ88 density.

C.2 Modifications Required for SunOS 4.1.x

C.2.1 Installation Procedure

NOTE

In order to support the addition of this device, the applicable drive information must be supplied in the `/sys/scsi/targets/st_conf.c` file. For additional information, read the **man** pages for `st`.

C.2.1.1 System Modification

Perform the following steps to modify the system for communication with the TZ88 Model 20/40 GB DLT tape drive:

1. From the command line, type:

```
cd /sys/scsi/targets
```
2. Edit the `"st_conf.c"` file and *carefully* add the following structure before the entry for `"/*` Exabyte 8mm 5GB cartridge `*/"`:

```

/* TZ88 40GB DLT Streaming /w Compression Cartridge tape drive */
{
  "DEC TZ88 40GB Cart. DLT Steaming /w Compression", 12 ,
  "DEC      TZ88", ST_TYPE_DEFAULT, 0,
  (ST_BSF | ST_VARIABLE | ST_LONG_ERASE | ST_KNOWS_EOD),
  5000, 5000,
  { 0x80, 0x81, 0x82, 0x83 },
  { 0, 0, 0, 0 }
},

```

3. Verify that the above entry is added to the `st_conf.c` file correctly.

Where,

- The first parameter (DEC TZ88 40GB Cart. DLT Streaming /w Compression) is the name given to the drive.
- The second parameter (12) is the length of the vendor ID provided by the "inquiry" command.
- The third parameter (DEC TZ88) is the vendor ID. (Ensure that five spaces are included between "DEC" and "TZ88" elements.)
- The fourth parameter (ST_TYPE_DEFAULT) is the drive type for the driver.
- The fifth parameter (0) is the block size in bytes. Zero "0" means variable block size.
- The sixth parameter (ST_BSF | ST_VARIABLE | ST_BSR | ST_LONG_ERASE | ST_KNOWS_EOD) comprises the drive options.
- The seventh parameter (5000) is the maximum number of read retries.
- The eighth parameter (5000) is the maximum number of write retries.
- The ninth parameter (0x80, 0x81, 0x82, 0x83) comprises the density codes (low-high) as defined below:

NOTE

In our example entry we choose to use TZ87 native and compressed modes for the two lower densities and TZ88 native and compressed modes for the two higher density drivers. Because your situation may demand something other than these settings, we have included Table C-1 which lists all other valid density values. Refer to Table C-1 for other density settings.

- 0x80 is the vendor-unique density code for the TK87 (10 GB).
- 0x81 is the vendor-unique density code for TK87 (20 GB).
- 0x82 is the vendor-unique density code for the TK88 native in the uncompressed mode (20 GB).
- 0x83 is the vendor unique code for the TK88 in the compressed mode (40 GB).
- The tenth parameter (0,0 . . .) is the speed code (not used).

Table C–1 Density Codes for Sun and Solaris

Density Code	Meaning
00h	Use default density
0Ah	TK50 – 6667 bpi MFM serial cartridge tape X3B5/86-199 (read-only)
16h	TK70 – 10000 bpi MFM serial cartridge tape X3.193-1990 (read-only)
17h	TK85 – 42500 bpi FMF serial cartridge tape X3B5/91-1174, 2.6 GB
18h	TK86 – Same as TK85 except with 56 track pairs versus 24, 6.0 GB
19h	TK87 – 62500 bpi, 64 track pairs, serial cartridge tape, 10 GB
1Ah	TK88 – 81633 bpi, 64 track pairs, serial cartridge tape, 20 GB (without compression)
7Fh	No change from previous density (Mode Select)
80h	TK87 – 62500 bpi, 64 track pairs, serial cartridge tape, 10 GB (without compression)
81h	TK87 – 62500 bpi, 64 track pairs, serial cartridge tape, 20 GB (with compression)
82h	TK88 – 81633 bpi, 64 track pairs, serial cartridge tape, 20 GB (without compression)
83h	TK88 – 81633 bpi, 64 track pairs, serial cartridge tape, 40 GB (with compression)

C.2.1.2 Rebuilding of Kernel

After you have edited the "**st_conf.c**" file and added the above entry, rebuild the kernel using the standard procedure (for further help, refer to the **man** pages of the **config** command).

C.2.1.3 Installation of tape drive

Install the tape drive into the storage subsystem and power on the workstation. We recommend that the TZ88 Model 20/40 GB DLT SCSI device address be set to ID 4 or 5.

NOTE

If your SCSI host adapter is supported by the "probe-scsi" command, you can use this command at the boot prompt to verify that the connected device is correctly attached to the system.

C.2.1.4 Rebooting of system

Reboot the system, using the following command at the boot prompt:

```
>boot
```

The system reboots with the newly compiled kernel and creates special files in **/dev** so that it can communicate with the TZ88 Model 20/40 GB DLT SBB. Verify that "DEC TZ88 20GB Cart. DLT Streaming /w Compression" is displayed as a target when the system is booting.

At this time the tape is configured in the **/dev** directory with "**rst**" (rewind on close) and "**nrst**" (no rewind on close) format. If the entry in the kernel configuration file for the SBB were **st4**, for example, then "**rst**" would be "**rst4, rst12, rst20, rst28**" and **nrst** would be "**nrst4, nrst12, nrst20, nrst28**".

- *rst4* and *nrst4* correspond to the 0x80 density mode (TK87 format)
- *rst12* and *nrst12* correspond to the 0x81 density mode (TK87 compressed format)
- *rst20* and *nrst20* correspond to the 0x82 density mode (TK88 native format)
- *rst28* and *nrst28* correspond to the 0x83 density mode (TK88, *compressed* format)

C.2.1.5 Testing the TZ88 Model 20/40 GB DLT SBB

To test the drive, back up the “**passwd**” file to tape using the “tar” command, as follows:

```
tar cvf /dev/rst4 /etc/passwd
```

The system responds with:

```
a /etc/passwd 1 blocks
```

Note that depending on the size of the file, a different number of blocks may be reported.

C.2.1.6 Verification

Verify that the “**passwd**” file was written to tape using the following command:

```
tar tvf /dev/rst4
```

The system responds with:

```
/etc/passwd
```

The installation and verification procedure is now complete.

C.2.2 Dump Parameters for the Tape Drive

The parameters that should be used when running the dump utility with the tape drive are:

```
density = 81633 (BPI)
size = 1800 (1800-foot tape)
blocking factor = 126
```

Example 1

The following example shows backing up the entire disk partition onto the tape drive:

```
dump 0dsbf 81633 1800 126 /dev/rst28 /dev/sd0g
```

For further help, refer to **man** pages of the **dump** command.

C.3 Modifications Required for Solaris 2.3 (or later)

C.3.1 Installation Procedure

NOTE

In order to support the addition of this device, drive information must be supplied in the `/kernel/drv/st.conf` file as global properties that apply to each of the targets, or as properties that are applicable to one target only. The "st driver" looks for the property called "tape-config-list". For additional information, read the man page "st". We recommend here the use of the global properties approach.

C.3.1.1 System Modification

Perform the following steps to modify the system to communicate with the tape drive:

1. From the command line, type:

```
cd /kernel/drv
```

2. Edit the "st.conf" file by adding the following before the first occurrence of "name=":

```
# entry for TZ88 tape drive
tape-config-list = "DEC      TZ88",
"DEC 40GB Cart. DLT Streaming /w Compression", "TZ88-data";
TZ88-data = 1,0x36,0,0x1639,4,0x80,0x81,0x82,0x83,3;
```

where:

In the "tape-config-list" parameter:

- The first parameter (DEC TZ88) is the parameter returned by the TZ88 Model 20/40 GB DLT SBB on a SCSI inquiry command. (There should be five spaces between "DEC" and "TZ88" elements.)
- The second parameter (DEC 40GB Cart. DLT Streaming /w compression) is a *nickname* for the drive.
- The third parameter is defined as follows:

In the "TZ88-data" string:

- The first parameter (1) is the revision level of the software and is set to 1. The first parameter (1) is the revision level of the software and is set to 1.
- The second parameter (0x36) is the **tape type**, specifying "other" tape drive. (This is defined in `/usr/include/sys/mtio.h`.)
- The third parameter (0) is the block size in bytes. Zero "0" means variable block size.

- The fourth parameter (0x1639) defines the options selected. The 0x1639 value represents the following options:

ST_VARIABLE	=	0x0001
ST_BSF	=	0x0008
ST_BSR	=	0x0010
ST_LONG_ERASE	=	0x0020
ST_KNOWS_EOD	=	0x0200
ST_UNLOADABLE	=	0x0400
ST_LONG TIMEOUTS	=	0x1000
- The fifth parameter (4) defines the number of densities. The maximum definable number of densities is 4, which is a Sun Operating System limitation.

NOTE

In our example entry we choose to use TZ87 native and compressed modes for the two lower densities and TZ88 native and compressed modes for the two higher density drivers. Because your situation may demand something other than these settings, we have included Table C-1 which lists all other valid density values. Refer to Table C-1 for other density settings.

- The sixth parameter (0x80) is the vendor-unique density code for the TK87, 10 GB.
- The seventh parameter (0x81) is the vendor-unique density code for TK87, 20 GB *compressed* mode.
- The eighth parameter (0x82) is the vendor-unique density code for the TK88, 20 GB.
- The ninth parameter (0x83) is the vendor-unique density code for the TK88 40 GB *compressed* mode.
- The last parameter in the **SWXTL-data** parameter is the default density 3, TK88 in the 40 GB *compressed* mode.

C.3.1.2 System Shutdown

After you have edited the “**st.conf**” file, shut down the system as follows:

```
sync
cd /
shutdown -i0 -g0 -y
```

C.3.1.3 Installation of the Tape Drive

Install the tape drive into the storage subsystem and power on the workstation. We recommend that the TZ88 Model 20/40 GB DLT SCSI device address be set to ID 4 or 5.

NOTE

If your SCSI host adapter is supported by the “`probe-scsi`” command, then you can use this command at the boot prompt to verify that the connected device is correctly attached to the system.

C.3.1.4 Rebooting of System

Reboot the system using the following command at the boot prompt:

```
>boot -rv
```

Note that the switch "r" forces the kernel to be re-configured, and switch "v" enables a display of the system configuration at boot time.

The system compiles the kernel and creates special files in `/dev` so that it can communicate with the TZ88 Model 20/40 GB DLT SBB. Since you booted the system using the verbose switch, the system displays all of its SCSI targets. Verify that "DEC 40GB Cart. DLT Streaming /w Compression" is displayed as a target when the system is booting.

At this time, the tape drive is configured in the `/dev` directory in two ways: **rmt** format, and **rst** format.

"rmt" format

In this format, the drive is configured with various options. For further explanations, see the man pages on "st" (the modes are *x*, *xl*, *xm*, *xh*, *xc*, and *xu*, where *x* is the **rmt** number).

- Options *x*, *xu*, and *xc*, correspond to the 0x83, (TK88, *compressed*) density mode.
- Option *xl*, corresponds to the 0x80 (TK87) density mode.
- Option *xm* corresponds to 0x81 (TK87) density mode.
- Option *xh* corresponds to 0x82 (TK88, *native*) density mode.
- Option *b* associates with the BSD behavior and is for backward compatibility on all of the above options. For further information, refer to the man pages of "mtio".
- The *n* option provides access to the device with **no rewind**, similar to **nrst** (below), and is also applicable to all of the above options.

"rst" format

Special files "**rst**" (rewind on close) and "**nrst**" (no rewind on close) are also built and reside in the `/dev` directory. For example, if the SCSI target ID for the drive is 4 and the drive is connected to the native SCSI bus, then "**rst**" will be "**rst4**, **rst12**, **rst20**, and **rst28**" and **nrst** will be "**nrst4**, **nrst12**, **nrst20**, and **nrst28**".

- **rst4** and **nrst4** correspond to the 0x80 density mode (TK87 *native* format)
- **rst12** and **nrst12** correspond to the 0x81 density mode (TK87 *compressed* format)
- **rst20** and **nrst20** correspond to the 0x82 density mode (TK88, *native* format)
- **rst28** and **nrst28** correspond to the 0x83 density mode (TK88, *compressed* format)

C.3.1.5 Test

To test the TZ88 Model 20/40 GB DLT drive, back up the “**passwd**” file to tape using the “tar” command, as follows:

```
tar cvf /dev/rst4 /etc/passwd
```

The system responds with:

```
a /etc/passwd 1 blocks
```

Note that, depending on the size of the file, a different number of blocks may be reported.

C.3.1.6 Verification

Verify that the “**passwd**” file was saved to tape using the following command:

```
tar tvf /dev/rst4
```

The system responds with

```
/etc/passwd
```

The installation and verification procedure is now complete.

C.3.2 Running Sun Diagnostics (Optional)

The diagnostic exerciser provided with the Sun operating system (“sundiag”) does not support the generic DLT tape drive configuration. In order to run “sundiag”, you must modify the `st.conf` file in the `/kernel/drv` directory. Change the “**tape type**” in the `SWXTL-data` parameter from `0x36` (generic other type of drive) to `0x29` (Exabyte 8500 8mm cartridge) and re-boot the system with the “`boot -r`” option. You can now run “sundiag” when the system is up and running.

CAUTION

Remember to change the “**tape type**” back to `0x36` and reboot the system with the “`boot -r`” option after running “sundiag”.

C.3.3 Dump Parameters for the Tape Drive

The parameters that should be used when running the `ufsdump` utility with the tape drive are as follows:

```
density (d) = 81633 (BPI)
```

```
blocking factor = 126
```

Example,

The following parameter is an example of how to back up the entire disk partition (`/dev/rdisk/c0t3d0s6`) onto the tape drive:

```
ufsdump 0dbf 81633 126 /dev/rmt/dev/rdisk/c0t3d0s6
```

D

Product Notes for IBM™ RS/6000

This appendix provides information for the system administrator. It should be read before installing and using the SWXTL-CA tape drive SBB with a host system with the AIX 3.2.5 (or later) operating system.

D.1 Modifications Required to Operate the SWXTL-CA with AIX 3.2.5 (or later)

After the SWXTL-CA tape drive has been properly attached to the SCSI bus, install the device using "smit" or by executing specific commands while logged into the root account. Section D.1.1 below describes how to install the tape drive using the fast-path command (`smit dev`). Section D.1.2 describes how to install the device using the command-line interface.

D.1.1 Installing the SWXTL-CA Using the SMIT Command

While the SWXTL-CA can operate with a variable block size (0, specified) or the conventional values of 512 or 1024, for best performance, use a block size of at least 10240.

1. From the command line, type:

```
# smit dev
```

2. Select menu entry "Configure the devices you have added after the IPL".
3. Select menu entry "Change/show the characteristics".
 - a) Select the entry that matches the controller and target ID of your installation.
Example: rmt1 available 00-03-00-50 other SCSI tape drive
where **3** is the SCSI controller number and **5** is the SCSI target ID
 - b) On the menu, change the settings of the "BLOCK size", "DENSITY setting #1", and "DENSITY setting #2".
Set "BLOCK size" to **10240**.
Set "DENSITY setting #1" to **131**.
Set "DENSITY setting #2" to **130**.
Density codes are listed in Section D.1.2 below.
 - c) Accept the changes.

D.1.2 Installing the SWXTL-CA Using Command-Line Interface

1. From the command line, type:

```
# cfmgr
```

2. To determine which *rmt* has been added, type:

```
# lsdev -Cc tape
```

Example:

```
# lsdev -Cc tape
```

```
Name      Status      Location      Description
rmt0     Available   00-03-00-50  Other SCSI Tape Drive
```

3. Next, type:

```
# chdev -l <rmt*> -a density_set_1=131 -a density_set_2=130
```

4. Finally, type the following:

```
# chdev -l <rmt*> -a block_size=<SIZE>
```

Example:

```
# chdev -l rmt0 -a block_size=10240
rmt0 changed
```

where,

<rmt *> is the tape drive added as shown by the *lsdev* command.

<SIZE> is the fixed block size (0 = variable, 10240 is suggested).

Density code “131” specifies compressed format while “130” specifies uncompressed format. In rare cases, other density codes may be useful. The legal values for the density code are listed in the following table:

Density Code	Meaning
10	TK50 – 6667 bpi FMF serial cartridge tape X3B5/86-199 (read-only)
22	TK70 – 10000 bpi FMF serial cartridge tape X3.193-1990 (read-only)
23	TK85 – 42500 bpi FMF serial cartridge tape X3B5/91-1174, 2.6 GB
24	TK86 – Same as TK85 except with 56 track pairs versus 24, 6.0 GB
25	TK87 – 62500 bpi, 64 track pairs, serial cartridge tape, 10 GB
26	TK88 – 81633 bpi, 64 track pairs, serial cartridge tape, 20 GB (without compression)
127	No change from previous density (Mode Select)
128	TK87 – 62500 bpi, 64 track pairs, serial cartridge tape, 10 GB (without compression)
129	TK87 – 62500 bpi, 64 track pairs, serial cartridge tape, 20 GB (with compression)
130	TK88 – 81633 bpi, 64 track pairs, serial cartridge tape, 20 GB (without compression)
131	TK88 – 81633 bpi, 64 track pairs, serial cartridge tape, 40 GB (with compression)

The files that are created are:

Tape Drive Special File Characteristics			
Special File Name	Rewind-on-Close	Retention-on Open	Bytes-per-Inch
/dev/rmt*	Yes	No	Density Setting # 1
/dev/rmt*.1	No	No	Density Setting # 1
/dev/rmt*.2	Yes	Yes	Density Setting # 1
/dev/rmt*.3	No	Yes	Density Setting # 1
/dev/rmt*.4	Yes	No	Density Setting # 2
/dev/rmt*.5	No	No	Density Setting # 2
/dev/rmt*.6	Yes	Yes	Density Setting # 2
/dev/rmt*.7	No	Yes	Density Setting # 2

NOTES

1. The suggested values of *density setting #1* and *#2* are for compressed and uncompressed format respectively. The only use of uncompressed format is to determine the relative effectiveness of the compressed mode.
2. The *density value* can be useful in reading tapes on earlier TK50, TK70, TK85, and TK86 cartridges.
3. IBM-supplied tape drives default to a block size of 1024 while tape drives from other manufacturers default to a block size of 512. StorageWorks recommends changing the block size of the SWXTL-CA to be compatible with the IBM-supplied drives. However, for some uses such as making bootable tapes or transferring tapes between host systems, a value of 512 or 0 (variable size) may be needed.

Product Notes for Hewlett-Packard

This appendix describes how to include the tape drive in an HP 9000 Series 700 system running HP-UX 9.05 or 10.01 and an HP 9000 Series 800 running HP-UX 9.04 or 10.01. The information covers configuration of the host system to communicate with the tape drive.

E.1 General Information

If the necessary drivers are not already built into your existing kernel, you will need to rebuild your kernel.

When using the **dump** utility, you must supply the correct density code and tape length size for **dump** to use in its calculations. Refer to Section E.6 for details. We recommend a value of 126 for the blocking factor parameter.

For this device to be recognized and operational on the S800 servers, its personality was changed to that of an EXABYTE 8505. Ensure you have the SWHTL part number, not the SWXTL one.

E.2 Modifications Required

E.2.1 Installation Procedure

NOTES

The "EXABYTE EXB-8505" designation in the following procedure is the StorageWorks internal name for the SWHTL part number. The "DEC TZ88" designator is the StorageWorks internal name for the SWXTL part number.

E.2.1.1 Installation of Tape Drive

Install the tape drive into the StorageWorks enclosure and power-on the workstation. Ensure that the address of the tape drive does not conflict with the address of any other device on that SCSI bus.

E.2.1.2 System Modification

Enter the System Administration Manager (SAM) as superuser. From the first-level menu, choose **Peripheral Devices**. From the second-level menu, choose **Tape Drives**. The system's hardware will be scanned, and the "available tape drives" window will identify the tape drive as a SCSI Tape Drive (HP-UX 9.05, 9.04) or as a "EXB-8505 5 GB 8mm Tape Drive" (HP-UX 10.01) for the SWHTL, and as a "DEC TZ88" (HP-UX 10.01) for the SWXTL with the appropriate hardware path. Highlight that selection and then pull down the

Actions menu and select the **Add** function. The program at this time will check the kernel to determine if the necessary drivers are built in, displaying the results.

If necessary, the program will rebuild the kernel. If this occurs, you will have to reboot the system in order to use the tape drive. For further information on adding tape devices, refer to Hewlett-Packard's *Installing Peripherals* manual, P/N B2355-40041.

E.3 Series 700 System Device Files

The System Administration Manager program automatically creates the appropriate device files and places them in the **/dev/rmt** directory, when adding the device through SAM. Additionally, the device files are created automatically upon system initialization.

E.3.1 HP-UX 9.05

The following naming convention is used for the DLT-format tape drive, as shown in the examples listed below:

`/dev/rmt/c#d#[h|mc][n][b]`

where:

c# specifies the controller designation, which may contain either two or three characters, specifies the following:

where **#** is **sc[f]**, in accordance with the following:

s is the system bus module:

2 = core I/O (the default)

4 = EISA SCSI

c is the slot number:

0 for core I/O

n for EISA, the value is determined by the slot number as reported by the H/W path reported by "ioscan."

f is the function number. This value identifies the location on the core I/O bus. For the SCSI interface, the value is **1**. If you are using the EISA SCSI interface, the **f** value is 0.

d# designates the SCSI address of the tape drive, where **#** here identifies a number value.

h/l/m/c specifies density, with **h** meaning high density, **l** meaning low density, **m** meaning standard DDS format, and **c** meaning data compression.¹

n specifies no rewind on close.

b specifies Berkeley behavior.

For additional information about magnetic tapes drive operation, refer to **mt(7)** of the *HP-UX Reference* manual (P/N B 2355-90033) or the Man pages.

¹The **h**, **l**, and **m** device designations all yield the same result. The **c** device designation enables compression.

Examples

For a tape drive SBB installed in slot location 4 of the StorageWorks SWXSE-02 expansion enclosure connected to the main (core) SCSI bus, the following device files would be produced in the directory **/dev/rmt**:

c201d4c	c201d4l	c201d4cb	c201d4lb
c201d4cn	c201d4ln	c201d4cnb	c201d4lnb
c201d4h	c201d4m	c201d4hb	c201d4mb
c201d4hn	c201d4mn	c201d4hnb	c201d4mnb

For a tape drive SBB installed in slot location 4 of the StorageWorks SWXSE-02 expansion enclosure connected to a SCSI adapter in EISA slot 1, the following device files would be produced in the directory **/dev/rmt**:

c410d4c	c410d4l	c410d4cb	c410d4lb
c410d4cn	c410d4ln	c410d4cnb	c410d4lnb
c410d4h	c410d4m	c410d4hb	c410d4mb
c410d4hn	c410d4mn	c410d4hnb	c410d4mnb

E.3.2 HP-UX 10.01

The following naming convention is used on systems which support long filenames for the DLT format tape drive, as shown in the examples below:

`/dev/rmt/c#t#d#BEST[n][b]`

where:

c#	specifies the instance number of the interface card
t#	specifies the SCSI address of the tape drive
d#	specifies the device unit number (LUN) at the SCSI address
BEST	specifies the highest capacity density, which for this device is the TK88 compressed format
n	specifies no rewind on close
b	specifies Berkeley behavior

Examples

For a tape drive SBB installed in slot location 4 of the StorageWorks SWXSE-02 expansion enclosure connected to the main (core) SCSI bus, the following device files would be produced in the directory **/dev/rmt**:

c0t4d0BEST	c0t4d0BESTnb
c0t4d0BESTb	c0t4d0BESTnb

For systems which do not support long filenames, the following device naming convention is used:

#m #mb #mn #mnb

where:

- #** specifies an arbitrary number to distinguish this tape drive from others.
- n** specifies no rewind on close
- b** specifies Berkeley behavior

NOTE

This tape drive will read TK85 (2.6 MB), TK86 (6.0 MB) and TK87 (10.0) densities but will not write these densities to the above device files. Use the front panel override button to write these densities.

To list the device files associated with each device, issue the command “*ioscan -f -n/more*”.

E.4 Series 800 System Device Files

The System Administration Manager program automatically creates the appropriate device files and places them in the **/dev/rmt** directory, when adding the device through SAM. Additionally, the device files are created automatically upon system initialization.

E.4.1 HP-UX 9.04

The following naming convention is used for the tape drive SBB, as shown in the examples listed below:

`/dev/rmt/lu[1|m|h[c]][n][b]`

where:

- lu** specifies the logical unit as reported for the tape drive using the “*ioscan -f*” command:
- h/l/m/c** specifies density, with **h** meaning high density, **l** meaning low density, **m** meaning standard DDS format, and **c** meaning data compression.¹
- n** specifies no rewind on close.
- b** specifies Berkeley behavior.

For additional information about DDS tapes, refer to **mt(7)** of the *HP-UX Reference* manual (P/N B 2355-90033).

Example

If you were to install a tape drive SBB in the StorageWorks SWXSE-02 expansion enclosure, the following device files would be produced for the device having a logical unit number of 4 in the directory **/dev/rmt**:

4hc	4l	4hcb	4lb
4hnc	4ln	4hncb	4lnb
4h	4m	4hb	4mb
4hn	4mn	4hnb	4mnb

¹The **h**, **l**, and **m** device designations all yield the same result. To disable compression, use the front panel override button and select the desired density.

E.4.2 HP-UX 10.01

The following naming convention is used on systems which support long filenames for the DLT format tape drive SBB, as shown in the examples below:

```
/dev/rmt/c#t#d#BEST[n][b]
```

where:

- c#** specifies the instance number of the interface card
- t#** specifies the SCSI address of the tape drive
- d#** specifies the device unit number (LUN) at the SCSI address
- BEST** specifies the highest capacity density, which for this device is the TK88 compressed format
- n** specifies no rewind on close
- b** specifies Berkeley behavior

Examples

For a tape drive SBB installed in slot location 4 of the StorageWorks SWXSE-02 expansion enclosure connected to the main (core) SCSI bus, the following device files would be produced in the directory **/dev/rmt**:

```

c0t4d0BEST      c0t4d0BESTnb
c0t4d0BESTb    c0t4d0BESTnb

```

For systems which do not support long filenames, the following device naming convention is used:

```
#m  #mb  #mn  #mnb
```

where:

- #** specifies an arbitrary number to distinguish this tape drive from others.
- n** specifies no rewind on close
- b** specifies Berkeley behavior

NOTE

This tape drive will read TK85 (2.6 MB), TK86 (6.0 MB) and TK87 (10.0) densities but will not write these densities to the above device files. Use the front panel override button to write these densities.

To list the device files associated with each device, issue the command “*ioscan -f -n /more*”

E.5 Testing the Tape drive

To test the tape drive, back up the “passwd” file to tape using the “tar” command, as follows (use the correct device filename for the platform and operating system in use):

```
tar cvf /dev/rmt/c201d4h /etc/passwd
```

The system responds with something similar to the following:

```
a /etc/passwd 1 blocks
```

Note that depending on the size of the file, a different number of blocks may be reported.

E.5.1 Verification

Use the following command to verify that the “passwd” file was written to tape:

(use the correct device filename for the platform and operating system in use)

```
tar tvf /dev/rmt/c201d4h
```

The system responds with something similar to the following:

```
rw-r--r-- 0/10 535 Mar 23 16:31 1994 /etc/passwd
```

The installation and verification procedure is now complete.

E.6 Dump Parameters for the Tape Drive

The parameters that should be used when running the dump utility with the tape drive and a CompacTape IV data tape are:

density = 81633 (BPI)
size = 1800 (1800 foot tape)
blocking factor = 126 (recommended)

Example

The following example shows the command for backing up an entire disk partition onto the tape drive:

(use the correct device filename for the platform and operating system in use)

```
dump 0dsbf 81633 1800 126 /dev/rmt/c201d4h /dev/dsk/c201d6S0
```

For further help, refer to man pages of the **dump** command.

Reader's Comments

Manual Order Number:

EK-SM1TF-UG. A01

TZ88 Model 20/40 GB DLT Cartridge Tape Drive Family — SWXTL-CA StorageWorks Building Block (SBB) & SWXTL-CT Tabletop Tape Drives

Digital is committed to providing the best possible products and services. Since our manuals are important components of our products, we value your comments, corrections, and suggestions for improvements. Please take a few minutes to fill out and return this form, attaching additional sheets, if needed. Thank you.

Manual Rating	Excellent	Good	Fair	Poor
Accuracy (correct presentation of facts)	[]	[]	[]	[]
Completeness (adequate information)	[]	[]	[]	[]
Clarity (easy to understand)	[]	[]	[]	[]
Organization (logical sequence of information)	[]	[]	[]	[]
Layout (easy to follow subject matter)	[]	[]	[]	[]
Indexing (easy to locate desired information)	[]	[]	[]	[]

Errors Noted (please include page, paragraph, table or figure number)

Most-Liked Features

Least-Liked Features

Suggestions for Improvement

Return Address: Digital Equipment Corporation Customer Research Response Center ATTN: Nan Andrews Amish 334 South Street, SHR3-2/S27 Shrewsbury, MA 01545	_____
	Name _____ Phone _____

	Title _____

	Company _____

	Street Address _____

	Mail Stop _____

City _____ State _____ ZIP _____	

Country (if other than USA) _____	

